

M2-GO Antenna Properties

Type : PCB antenna
Model: M2-GO
Brand : RODE
Manufacturer: RODE

Version 2

20-12-2022

Joost ter Laak

JTL Engineering B.V.

Antenna 1

The plots below show the simulated directivity of antenna 1 @ 2.44 GHz, the directivity does not change significantly for 2.40 and 2.48 GHz.

The directivity of an antenna is defined as "the ratio of the radiation intensity in a given direction from the antenna to the radiation intensity averaged over all directions." The averaged radiation intensity is given by the total power radiated by the antenna divided by 4π .

The realized gain can be found by multiplying the efficiency with the directivity. For example for antenna 1 the simulated efficiency is -9.02 dB. From figure 3 it follows that the maximum realized gain of antenna 1 is $4.44 - 9.02 = -4.58$ dBi @ 2.44 GHz.

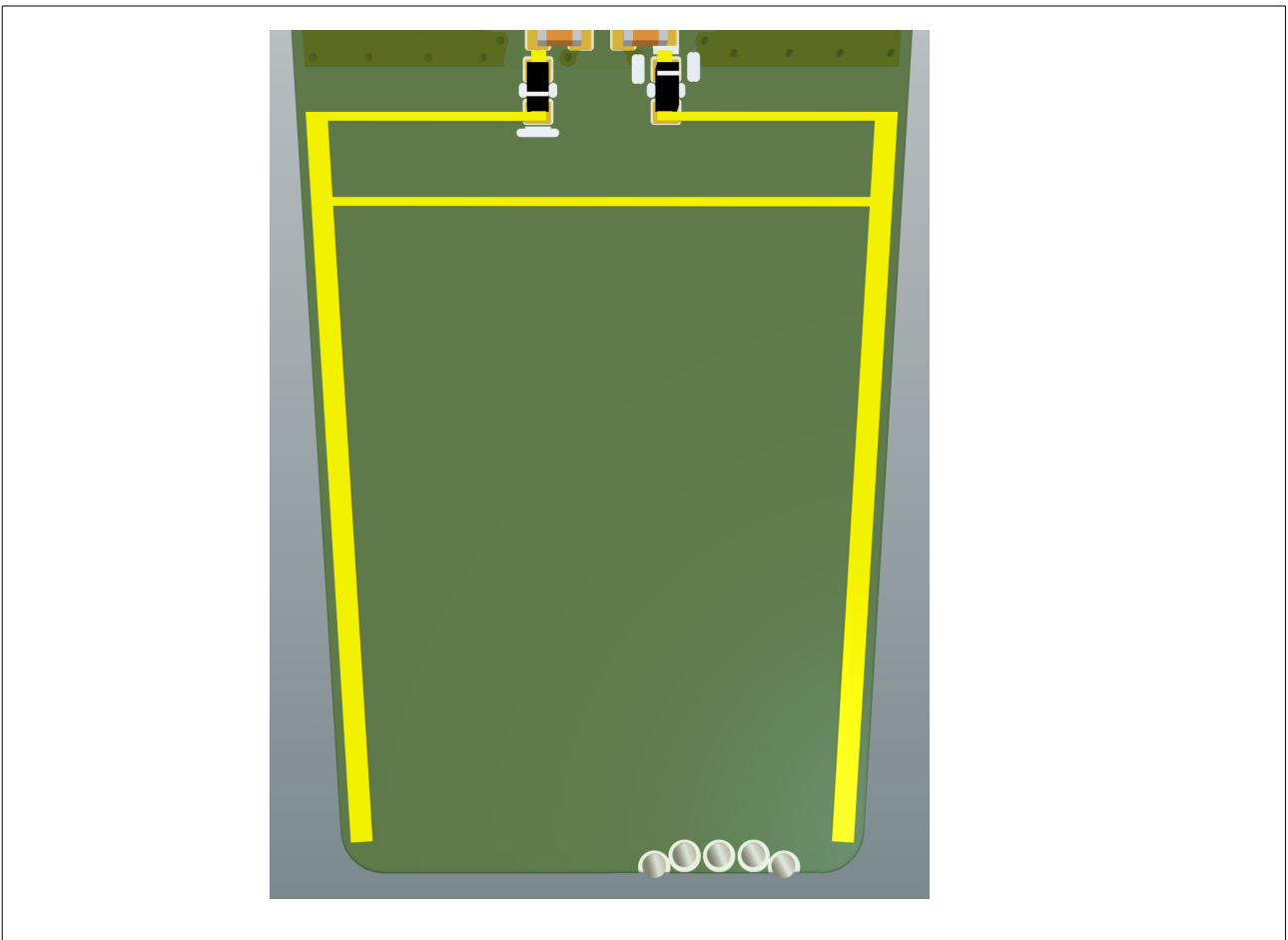

Figure 1: Antenna 1, it is 16.9 mm long and 13.9 mm wide.

Frequency [GHz]	Directivity [dBi]	Efficiency [dB]	Realized Gain [dBi]
2.40	4.35	-7.53	-3.18
2.44	4.44	-9.02	-4.58
2.48	4.56	-10.1	-5.55

Table 2: Properties for antenna 1 from simulation.

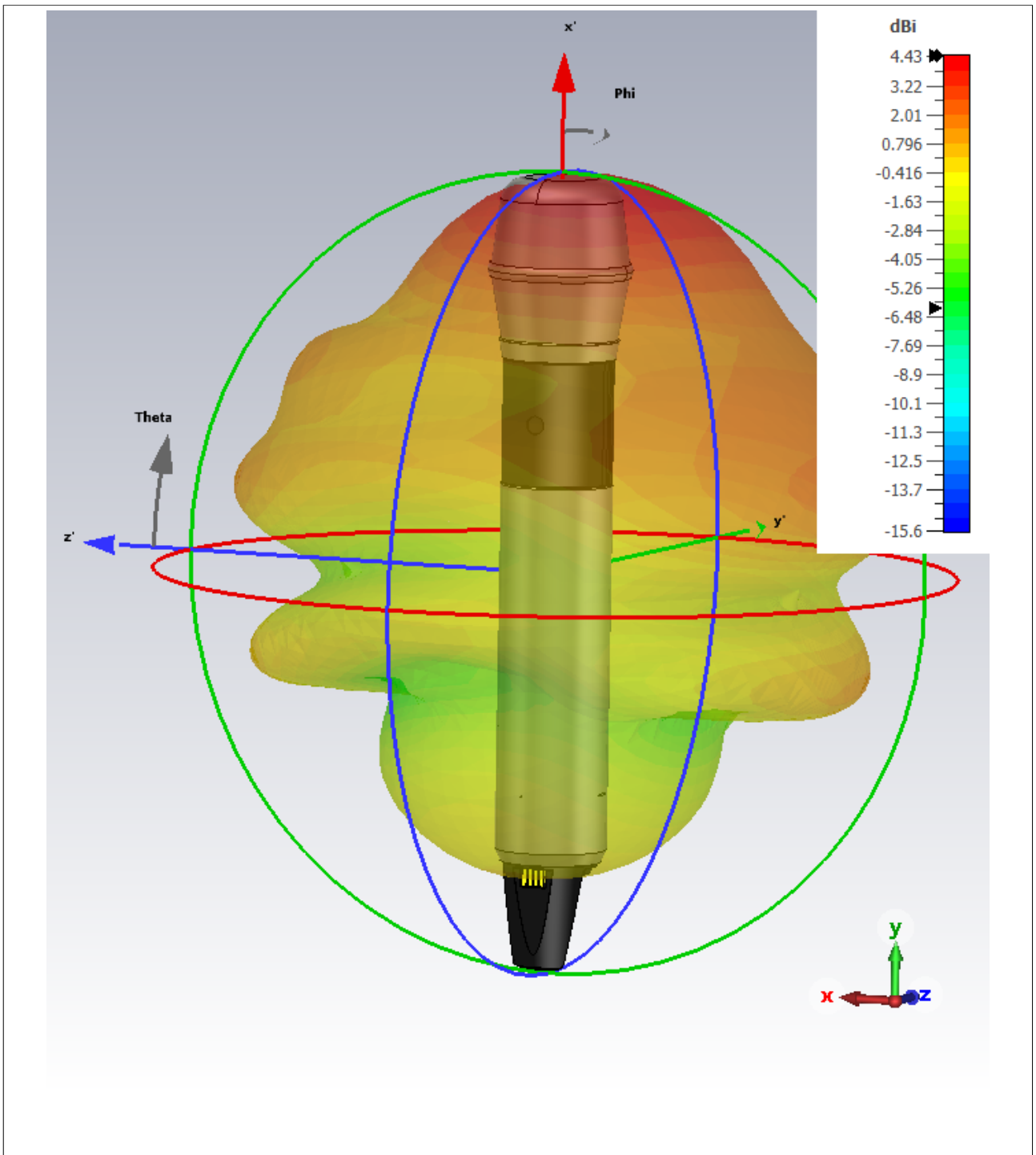

Figure 3: Directivity plot for antenna 1 at 2.44 GHz, note the orientation of theta and phi, for antenna 2 these are different.

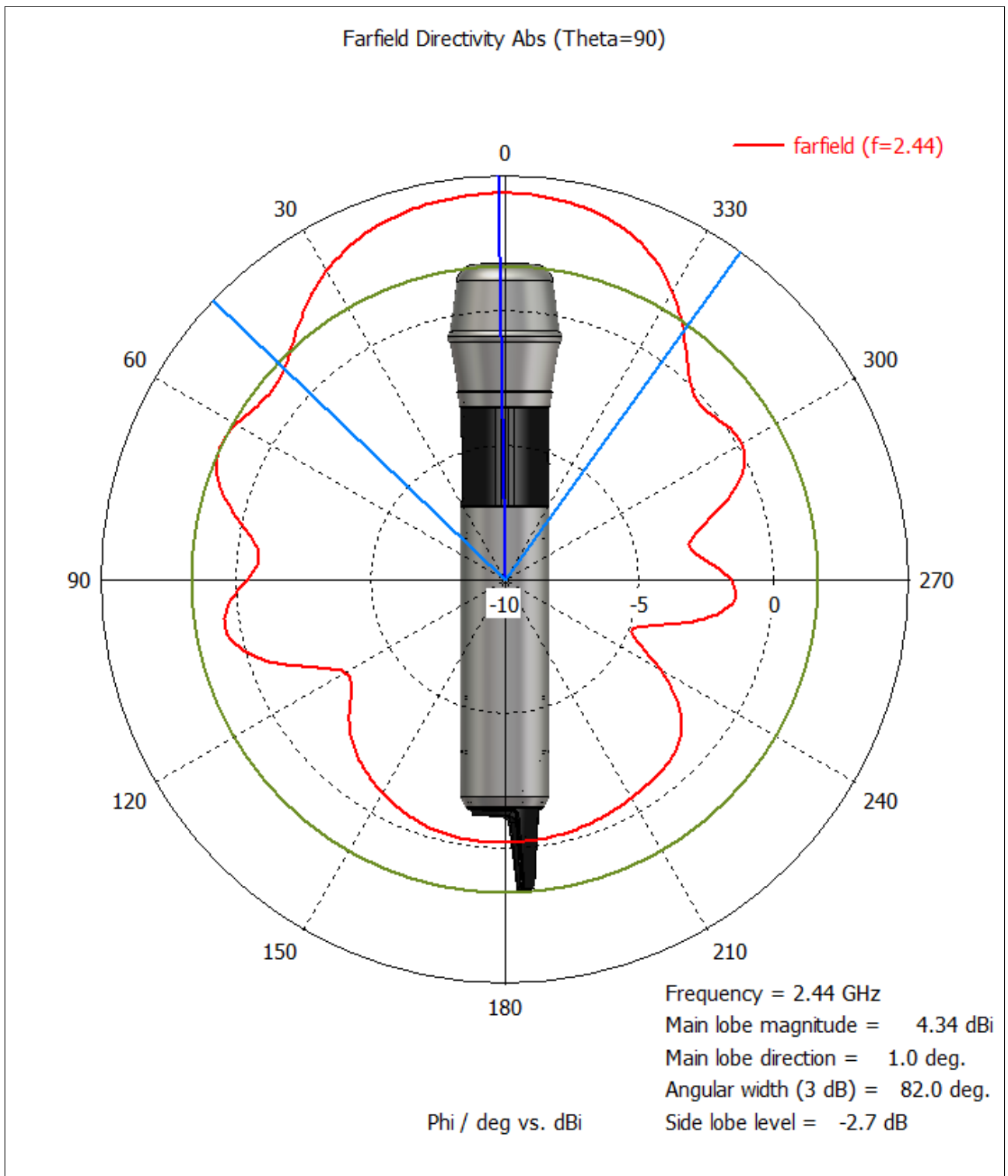

Figure 4: Directivity plot for the radiation of antenna 1 in the plane $\theta = 90^\circ$.

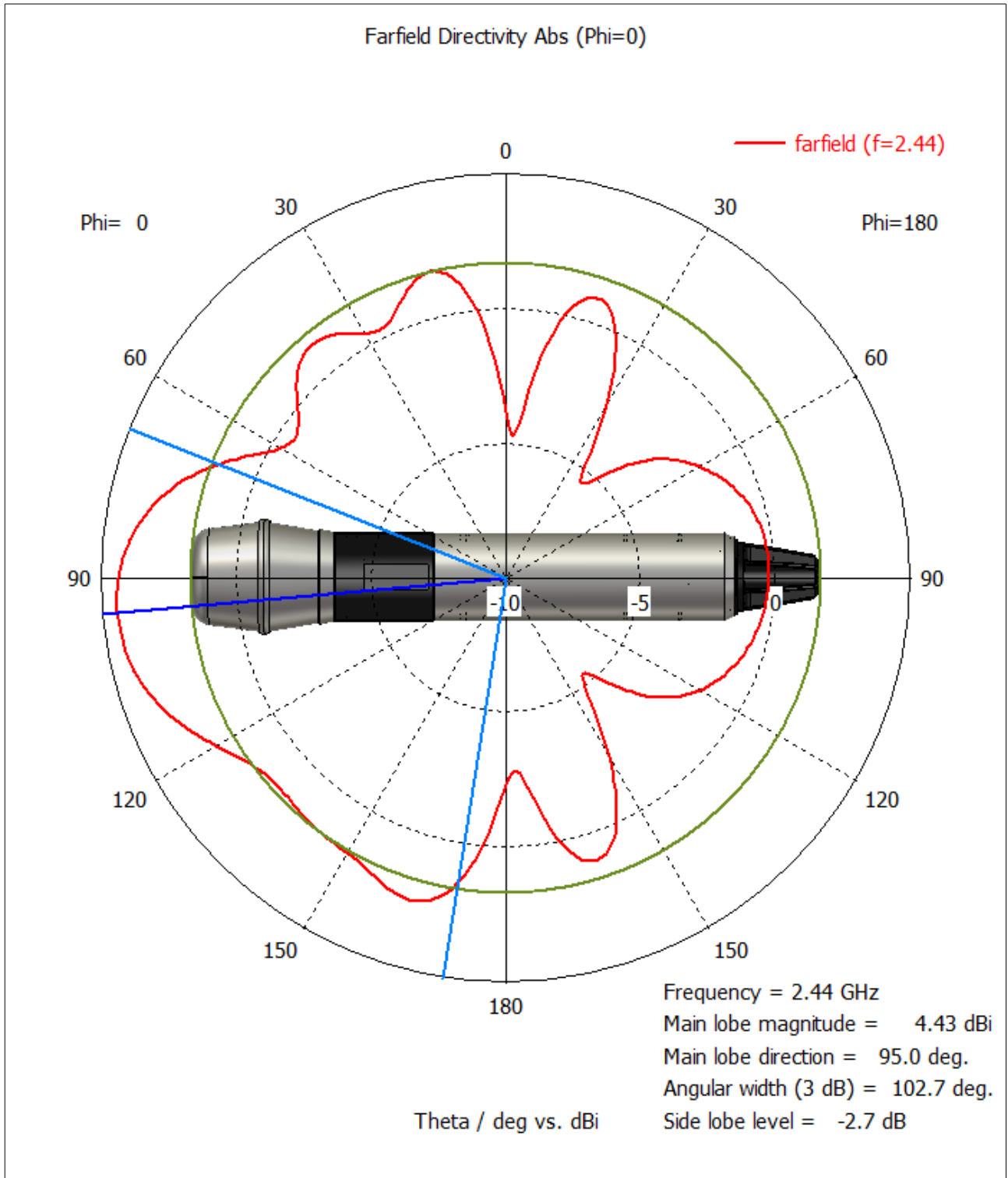

Figure 5: Directivity plot for the radiation of antenna 1 in the plane $\phi = 0^\circ$.

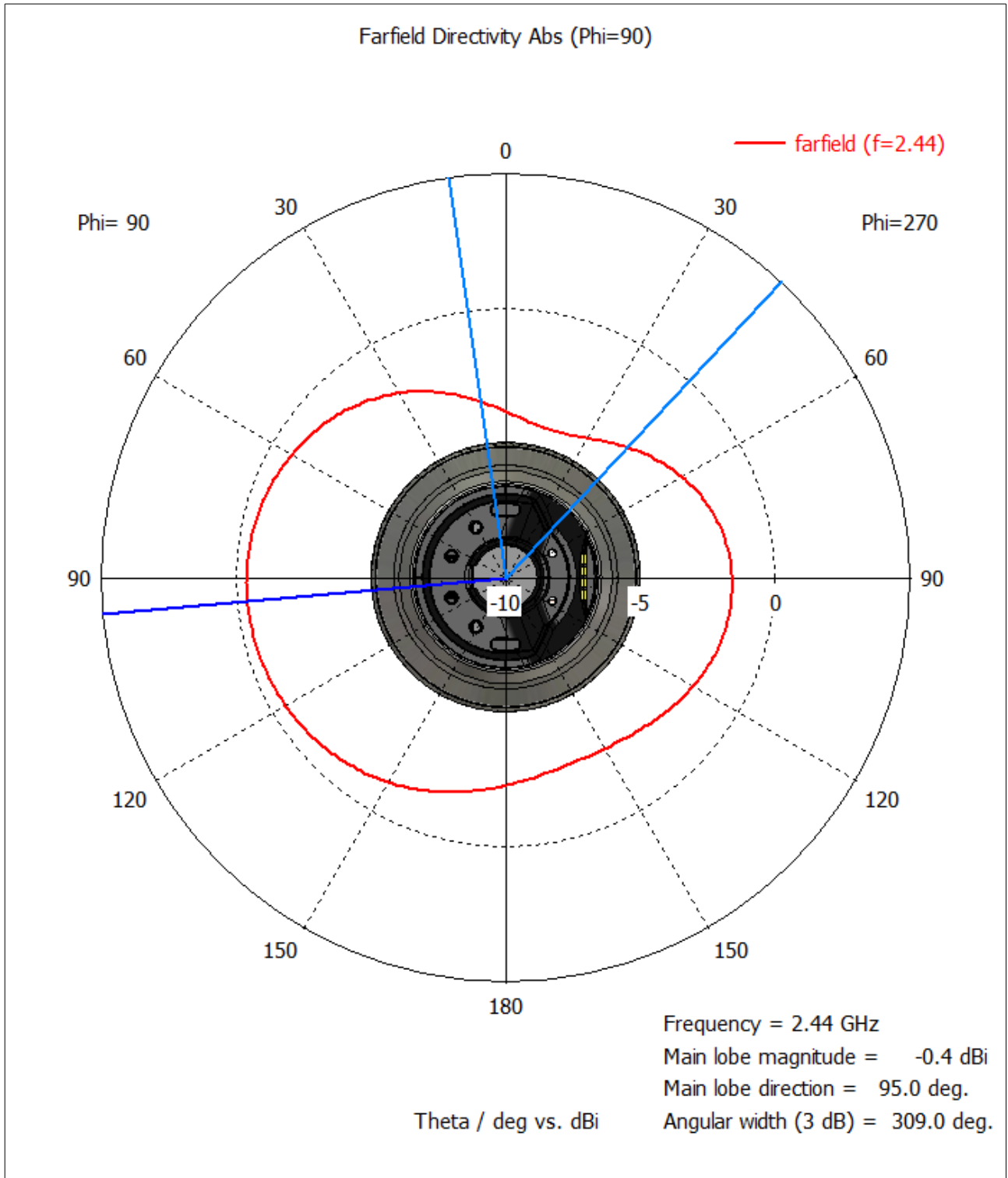

Figure 6: Directivity plot for the radiation of antenna 1 in the plane $\phi = 90^\circ$.

Antenna 2

The plots below show the simulated directivity of antenna 2 @ 2.44 GHz, the directivity does not change significantly for 2.40 and 2.48 GHz.

Frequency [GHz]	Directivity [dBi]	Efficiency [dB]	Realized Gain [dBi]
2.40	5.89	-2.44	3.45
2.44	5.72	-2.45	3.27
2.48	5.55	-2.48	3.07

Table 1: Properties for antenna 2 from simulation.

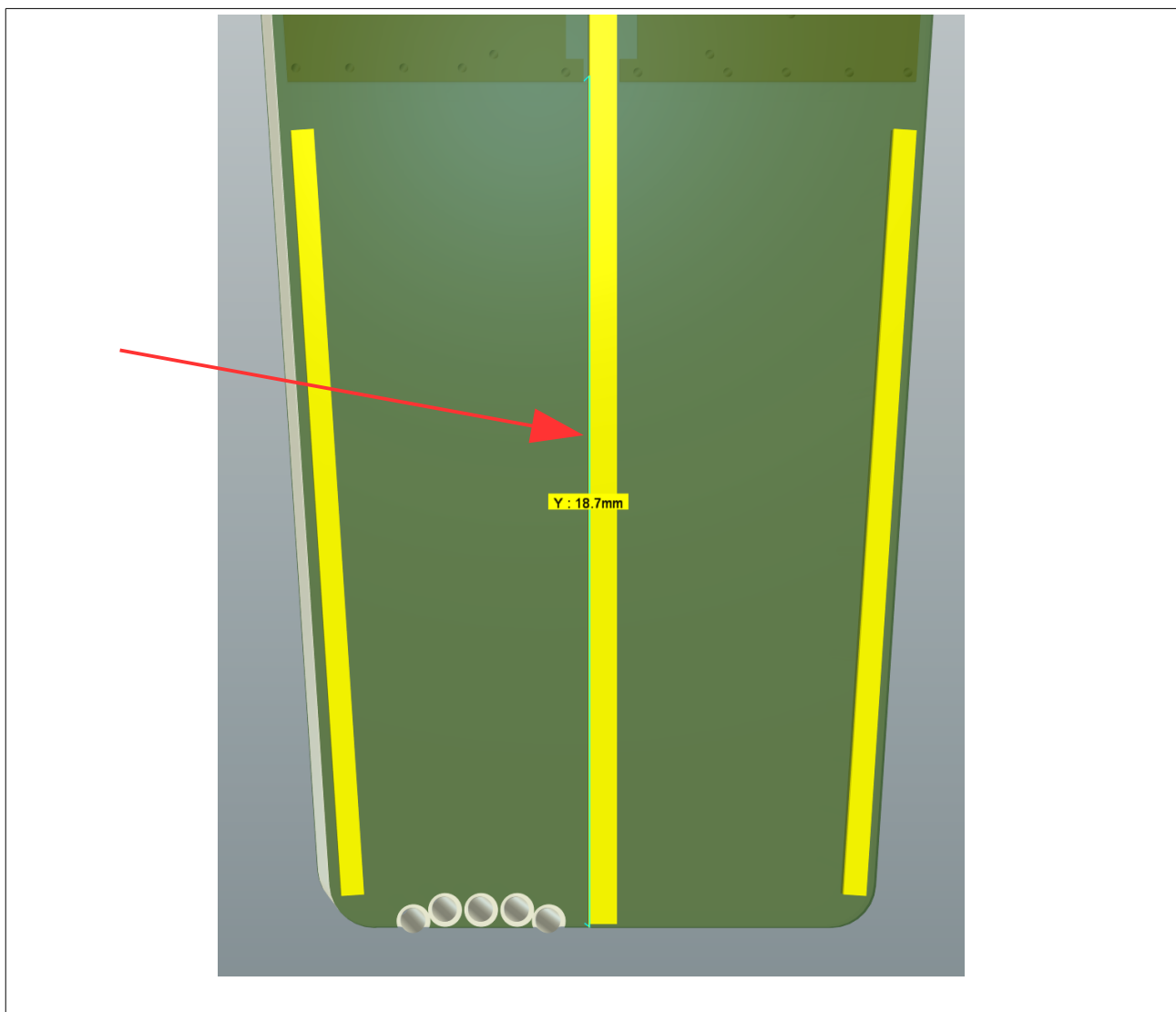

Figure 2: The trace pointed by the red arrow is antenna 2. It is 18.7 mm long and 0.6 mm wide..

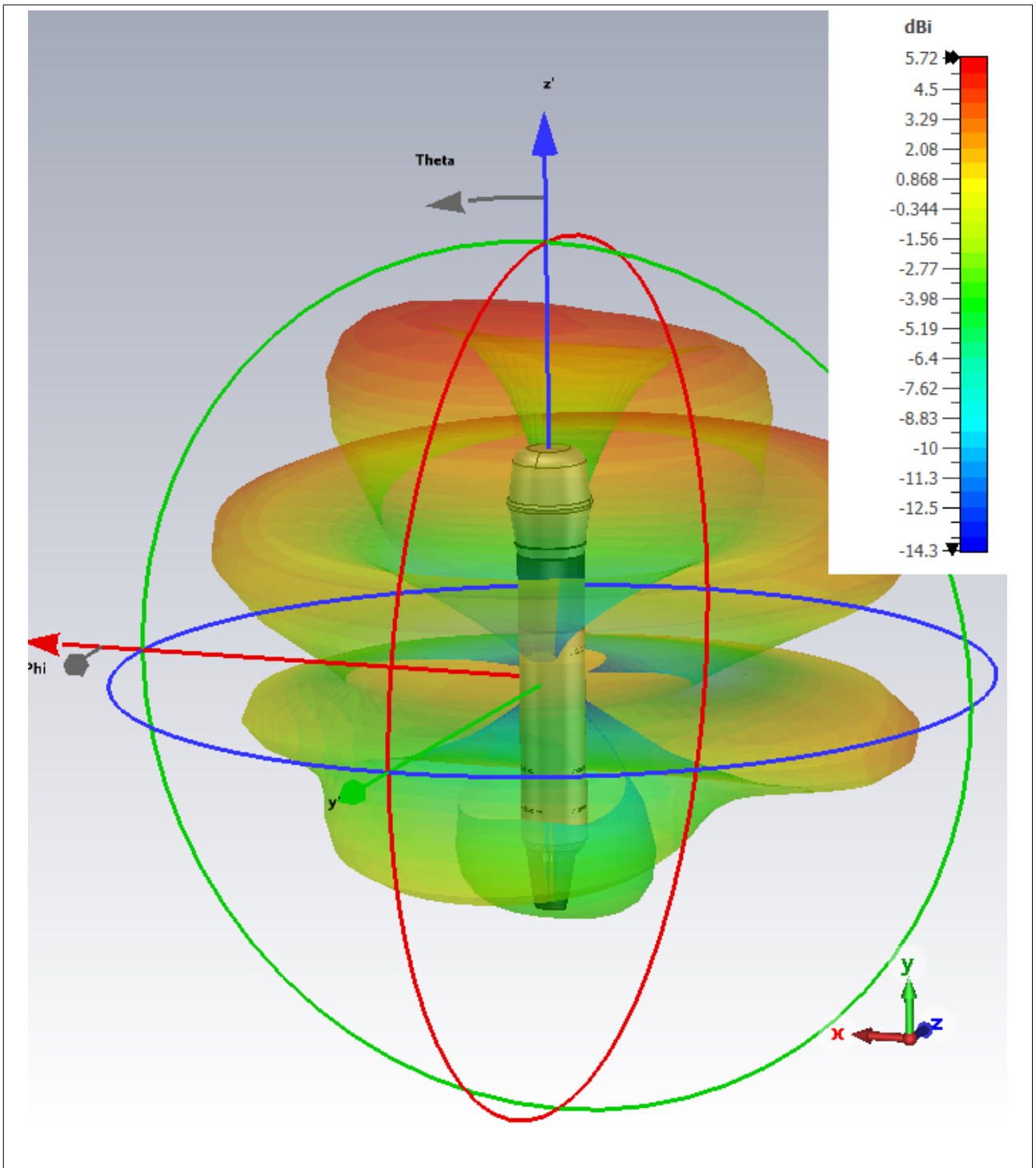

Figure 3: Directivity plot for antenna 2 at 2.44 GHz, note the orientation of theta and phi.

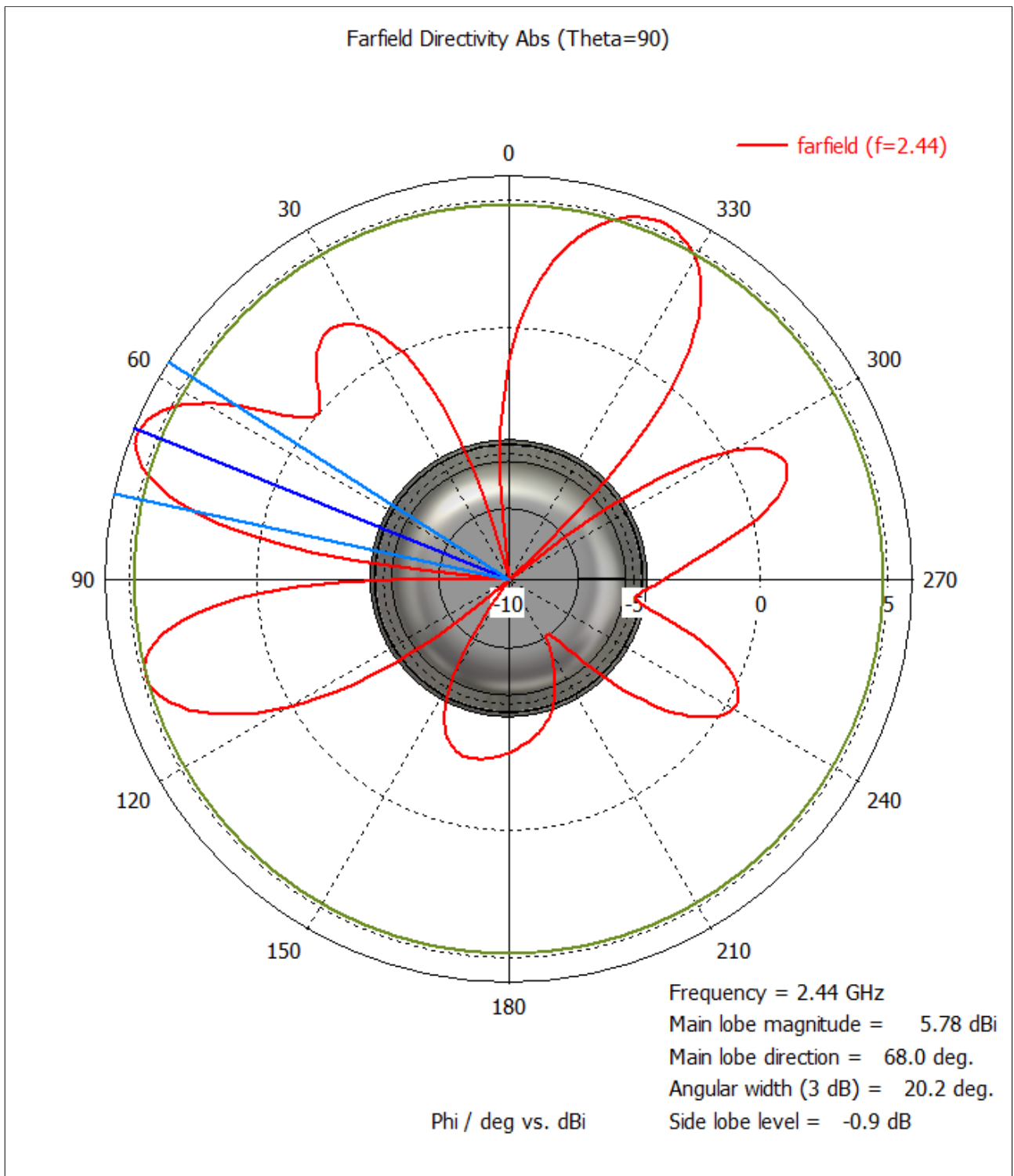

Figure 4: Directivity plot for the radiation of antenna 2 in the plane $\theta = 90^\circ$.

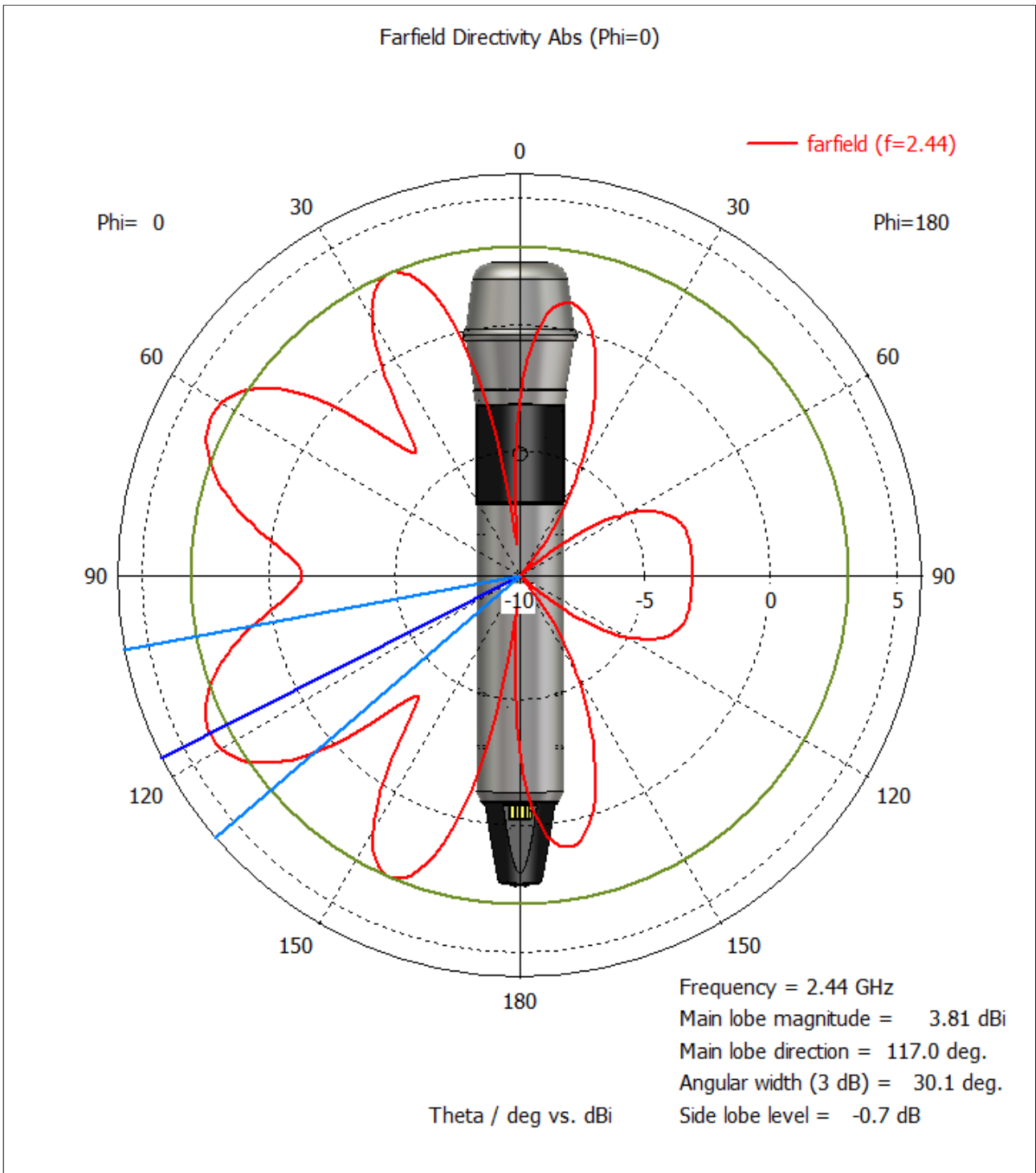

Figure 5: Directivity plot for the radiation of antenna 2 in the plane $\phi = 0^\circ$.

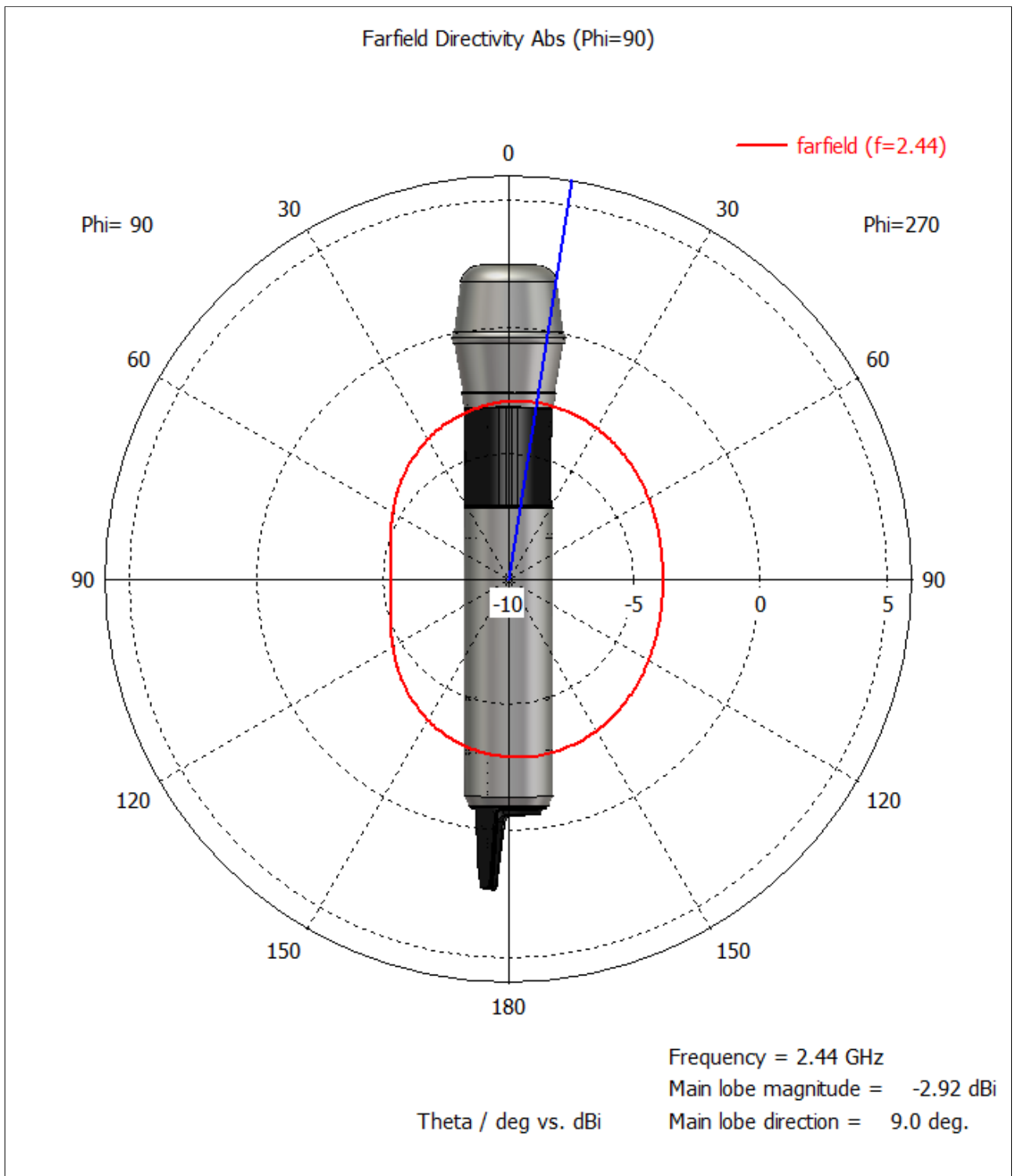

Figure 6: Directivity plot for the radiation of antenna 2 in the plane $\phi = 90^\circ$.