

FBee®

FZB5610 ZigBee Module

User Manual

V1.00

VERSIONS HISTORY

Versions	Date	Description	Mender
V1.00	Aug.18.2015	First release	Daniel

Contents

VERSIONS HISTORY.....	1
1 Product Introduction.....	3
1.1 Product Description.....	3
1.2 Product Figures.....	3
1.3 Applications.....	4
1.4 Product Features.....	4
2 Electrical Characteristics.....	5
2.1 Hardware Specification.....	5
2.2 Absolute Maximum Ratings.....	5
2.3 Recommended Operating Conditions.....	6
2.4 Recommended Output Power Setting.....	6
2.5 Power Characteristics.....	7
2.6 Temperature Characteristics.....	7
2.7 SPI AC Characteristics.....	8
2.8 DC Characteristics.....	9
2.9 RF Frequency,Output Levels and Data Rates.....	10
3 Terminal Configuration And Functions.....	11
3.1 Pin Assignments.....	11
3.2 Pin Attributes.....	11
3.2.1 ZigBee Transmission Module.....	11
3.2.2 ZLL Module.....	12
3.2.3 Curtain Module.....	13
3.2.4 Light Sensor Module.....	13
3.2.5 Infrared Human Body Sensor Module.....	14
3.2.6 Switch Module.....	15
3.2.7 Smart Plug Module.....	16
3.2.8 Temperature and Humanity Sensor Module.....	17
4 Reference Information.....	18
4.1 Electrical Schematic Diagram.....	18
4.2 Design Considerations.....	18
5 IEEE 802.15.4.....	19
6 The ZigBee Protocol.....	19
7 Mechanical Drawings And Installation.....	20
FCC compliance.....	22
COPYRIGHT STATEMENT.....	23
DISCLAIMER.....	23
TRADEMARK STATEMENT.....	23
Contact us.....	23

1 Product Introduction

1.1 Product Description

The FZB5610 ZigBee module is a compact surface-mounted modules specially designed for IEEE 802.15.4 and ZigBee applications.It enables robust network nodes to be built with very low total bill-of -material costs.The FZB5610 ZigBee module combines the excellent performance of a leading RF transceiver with an industry-standard enhanced 8051MCU,in -system programmable flash memory 8-KB RAM,and many other powerful features.The FZB5610 ZigBee module has 256KB flash memory and various operating modes,making it highly suited for systems where ultra low power consumption is required. Short transition times between operating modes further ensure low energy consumption. Combined with the industry-leading and golden-unit-status ZigBee protocol stack(Z-StackTM)from Texas Instruments,the FZB5610 ZigBee modules provides arobust and complete ZigBee solution.

Specification of FZB5610 ZigBee module as shown as table 1-1.

Table 1-1 Specification of FZB5610 ZigBee module

Specification	Parameter
Weight	5 g(including antenna)
Dimensions (depth×width×height)	15mm×28mm×2mm

1.2 Product Figures

Front side and Back side of FZB5610 ZigBee module as shown as figure 1-1 and figure 1-2.

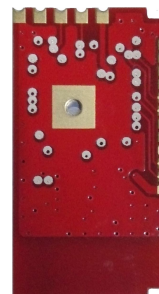
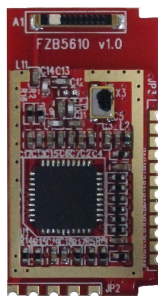

Figure 1-1 FZB5610 Front Side

Figure 1-2 FZB5610 Back Side

1.3 Applications

- 2.4-GHz IEEE 802.15.4 Systems
- RF4CE Remote Control Systems(64-KB Flash and Higher)
- ZigBee Systems(255-KB Flash)
- Home/Building Automation
- Lighting Systems
- Industrial Control and Monitoring
- Low-Power Wireless Sensor Networks
- Consumer Electronics
- Health Care

1.4 Product Features

- Follow IEEE802.15.4 Standard.
- High power consumption of the processor.
- Integrate with 2.4G low power consumption of transceiver.
- Use UART communication,and support to upgrade software by UART.
- Voltage supply 2.0V-3.6V.
- Conform to CE authentication.
- Conform to ZigBee Standard,support ZLL and ZHA.
- Support Ceramic Antenna or I-PEX Antenna(according to the model type)
- Hardware compatibility design of the front-end amplifier circuit(according to the model type)
- The circuit outside the antenna should be shield by metal.

2 Electrical Characteristics

2.1 Hardware Specification

FZB5610 specification as shown as table 2-1.

Table 2-1 FZB5610 Specification

Performances	Specification
Operating Frequency Band	2405~2480MHz
Transmitted Power	4dBm
Outdoor Accessible Communication Range	200m
Outdoor Accessible Network Range	100m
Receiver Sensitivity	-97dBm
Working Temperature	-40℃ ~ + 125℃
Supply Voltage	+2.0V ~ +3.6V (Recommend Value:+3.3V)
Standby Current	10mA (Non-sleeping) 1mA (PM1) 10μA (PM2) 1μA (PM3)
Operating Current	35mA(TX) 25mA(RX)
Modulation type of RF module	QPSK
Protocol	ZigBee HA/ZigBee Light Link

2.2 Absolute Maximum Ratings

Absolute maximum ratings of FZB5610 as shown as table 2-2.

Table 2-2 FZB5610 absolute maximum ratings

Parameter	Parameter Description	MIN	MAX	UNIT
Ts	Storage temperature range	-40	125	℃
Vi	Input/Output signal voltage in any pin	-0.3	3.9	V
Iin	IO port input power	-	100	mA
VESD	Electrostatic voltage	-2000	2000	V

2.3 Recommended Operating Conditions

The recommended operating conditions of FZB5610 as shown as table 2-3.

Table 2-3 FZB5610 recommended operating conditions

Parameter	Parameter Description	Min	Max	UNIT
TA	Operating environment temperature	-40	125	°C
VIH	High-level input voltage	1.85	3.14	V
VIL	Low-level input voltage	-0.3	0.9	V
VOH	High-level output voltage	2.4	3.3	V
VOL	Low-level output voltage	0	0.4	V
Io	Output current		4	mA

2.4 Recommended Output Power Setting

The recommended output power setting of FZB5610 as shown as table 2-4.

Table 2-4 FZB5610 recommended output power setting

TXPOWER Register Setting	Typical Output Power(dBm)	Typical Current Consumption(mA)
0xF5	4	34
0xE5	2	31
0xD5	0.5	29
0xC5	-1	28
0xB5	-2	27
0xA5	-3.5	27
0x95	-4.5	26
0x85	-6.5	26
0x75	-8.5	25
0x65	-10.5	25
0x55	-12.5	25
0x45	-14.5	25
0x35	-16.5	25
0x25	-18.5	24
0x15	-20.5	24
0x05	-22.5	23
0x05 and TXCTRL=0x09	-28.5	23

2.5 Power Characteristics

Power characteristics of FZB5610 as shown as table 2-5

Table 2-5 FZB5610 Power Characteristics

Parameter	MIN	TYP	MAX	UNIT
VDD	2.0	3.3	3.6	V

2.6 Temperature Characteristics

The relationship between output power and frequency as shown as figure 2-1.

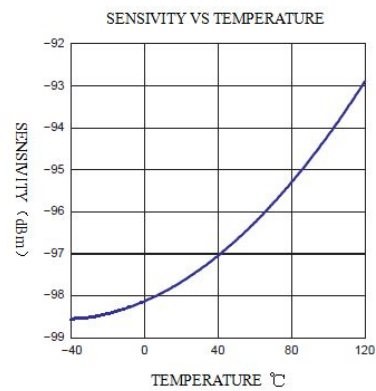
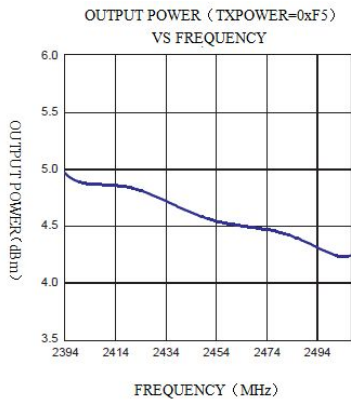

Figure 2-1 OUTPUT POWER VS FREQUENCY Figure 2-2 SENSITIVITY VS FREQUENCY

The relationship between sensitivity and temperature as shown as figure 2-2.

The relationship between output power and temperature as shown as figure 2-3.

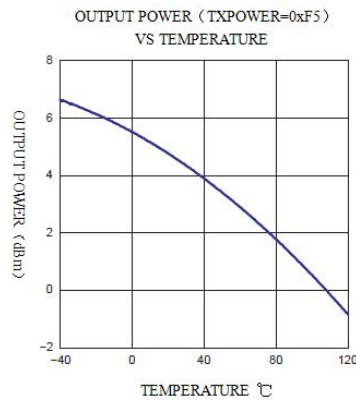

Figure 2-3 OUTPUT POWER VS TEMPERATURE

2.7 SPI AC Characteristics

(ref CC2530 datasheet)

TA = -40°C to 125°C, VDD = 2 V to 3.6 V, unless otherwise noted. See table 2-6.

Table 2-6 SPI AC Characteristics

PARAMETER	TEST CONDITIONS	MIN	TYP	MAX	UNIT
t ₁ SCK period	Master,Rx and Tx	250			ns
SCK duty cycle	Master		50%		
t ₂ SSN low to SCK	Master	63			ns
t ₃ SCK to SSN high	Master	63			ns
t ₄ MO early out	Master,load= 10 pF			7	ns
t ₇ MO late out	Master,load 10 = pF			10	ns
t ₆ MI setup	Master	90			ns
t ₅ MI hold	Master	10			ns
t ₁ SCK period	Stave,Rx and Tx	250			ns
SCK duty cycle	Stave		50%		
t ₂ SSN low to SCK	Stave	63			ns
t ₃ SCK to SSN high	Stave	63			ns
t ₆ MO setup	Stave	35			ns
t ₅ MO hold	Stave	10			ns
t ₅ MI late out	Stave,load = 10 pF			95	ns
Operating frequency	Master,Tx only			8	MHz
	Master,Rx and Tx			4	
	Stave,Rx only			8	
	Stave,Rx and Tx			4	

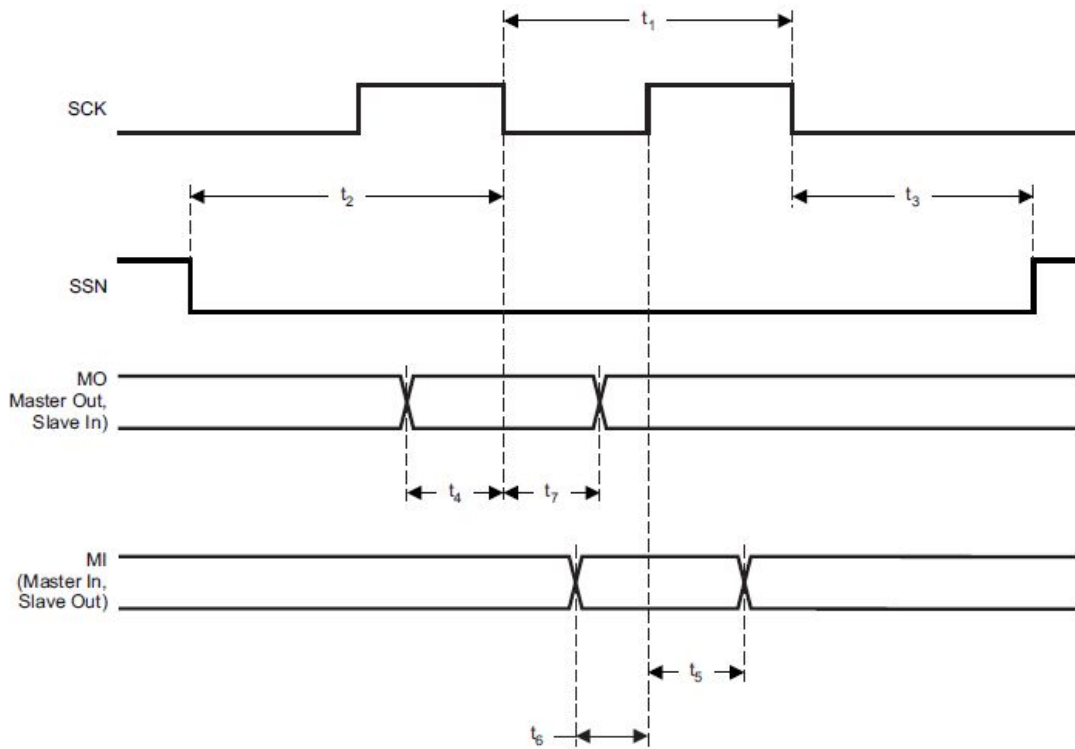

Figure 2-4 SPI AC Characteristics

2.8 DC Characteristics

TA = 25°C, VDD = 3 V, unless otherwise noted. See table 2-7.

Table 2-7 DC Characteristics

PARAMETER	TEST CONDITIONS	MIN	TYP	MAX	UNIT
Logic-0 input voltage				0.5	V
Logic-1 input voltage		2.5			V
Logic-0 input current	Input equals 0V	-50		50	nA
Logic-1 input current	Input equals VDD	-50		50	nA
I/O-pin pullup and pull down resistors			20		kΩ
Logic-0 output voltage,4-mA pins	Output load 4 mA			0.5	V
Logic-1 output voltage,4-mA pins	Output load 4 mA	2.4			V
Logic-0 output voltage,20-mA pins	Output load 20 mA			0.5	V
Logic-1 output voltage,20-mA pins	Output load 20 mA	2.4			V

2.9 RF Frequency, Output Levels and Data Rates

The following table shows the RF channels as defined by the IEEE 802.15.4 standard.

See table 2-8.

Table 2-8 RF channels

RF channel	Frequency
11	2405MHz
12	2410MHz
13	2415MHz
14	2420MHz
15	2425MHz
16	2430MHz
17	2435MHz
18	2440MHz
19	2445MHz
20	2450MHz
21	2455MHz
22	2460MHz
23	2465MHz
24	2470MHz
25	2475MHz
26	2480MHz

For proprietary solutions (non-IEEE 802.15.4), the RF transceiver can be programmed in steps of 1 MHz.

The RF transceiver uses direct sequence spread spectrum (DSSS) with 2 Mchip/s chip rate, giving a raw data rate of 250 kbit/s. The modulation format is Offset-Quadrature Phase Shift Keying (O-QPSK). The DSSS makes the communication link robust in noisy environments, which is beneficial when sharing the same frequency band with other applications.

3 Terminal Configuration And Functions

3.1 Pin Assignments

Pin assignments of FZB5610 ZigBee module as shown as Figure 3-1.

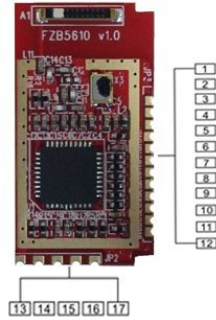

Figure 3-1 FZB5610 Module

3.2 Pin Attributes

3.2.1 ZigBee Transmission Module

Use FZB5610 ZigBee module as transmission module, the pin attributes as shown as table 3-1.

Table 3-1 Pin attributes of ZigBee Transmission Module (Corresponding Type: FZB5610-IR01-HA)

Pin number	Name	I/O	Description
1	VDD		Power (+3.3V)
2	KEY	I	FAC_NEW button
3	Nc.		
4	GND.		Ground
5	Nc.		
6	Nc.		
7	Nc.		
8	Status LED	O	State LED
9	Tx	O	Serial ports send Tx
10	Rx	I	Serial ports receive Rx
11	Nc.		

Pin number	Name	I/O	Description
12	Nc.		
13	GND.	Ground	
14	RESETn	I	System RESET signal,active low
15	DC	I	DEBUG port,leave unconnected
16	DD	I/O	DEBUG port,leave unconnected
17	VDD	I	Power (+3.3V)

3.2.2 ZLL Module

Use FZB5610 ZigBee module as transmission module,the pin attributes as shown as table 3-2.

Table 3-2 Pin attributes of ZLL Module(Corresponding Type:FZB5610 -CW02-ZLL (RGB)

/FZB5610-BW01-ZLL(Dimming))			
Pin number	Name	I/O	Descriptions
1	VDD	I	Power (+3.3V)
2	B-DRIVE	O	Blue LED PWM control signal
3	G-DRIVE	O	Green LED PWM control signal
4	GND.	I	Ground
5	Nc.		
6	Nc.		
7	Nc.		
8	Nc		
9	R-DRIVE	O	Red LED PWM control signal
10	FAC_RESE T		Factory reset button,press 5 seconds can reset to factory setting. Active low.
11	Nc		
12	IR_IN		Infrared remote control signal
13	GND.	Ground	
14	RESETn	I	System RESET signal,active low
15	DC	I	DEBUG port
16	DD	I/O	DEBUG port
17	VDD	I	Power (+3.3V)

3.2.3 Curtain Module

Use FZB5610 ZigBee module as curtain module,the pin attributes as shown as table 3-3.

Table 3-3 Pin attribute of ZigBee HA Smart Curtain Module(Corresponding Type:FZB5610-CUR01-HA)

Pin Number	Name	I/O	Descriptions
1	VDD	I	Power (+3.3V)
2	L-DRIVE	O	Control signal-Left
3	R-DRIVE	O	Control signal-Right
4	GND.	I	Ground
5	TSET	I	Test button signal,active low
6	R	I	Button signal,active low
7	STOP	I	Button signal-stop,active low
8	L	I	Button signal-right,active low.
9	Nc.		
10	FAC_RESET	I	Factory reset button,press 5 seconds can reset to factory setting. Active low.
11	Nc.		
12	Status	O	Operating Status Indicator,it can connect to LED.H : ON,L:OFF;if LED keeps on,the model is not in the ZigBee Network;if LED is off,the model is in the ZigBee Network.In this case,each time the model sends a ZigBee data,LED flashes one time.When exiting the network,LED flashes quickly.It will not flash until LED keeps on,that means logout succeed
13	GND.		Ground
14	RESETn	I	System RESET signal,active low.
15	DC	I	DEBUG port
16	DD	I/O	DEBUG port
17	VDD	I	Power (+3.3V)

3.2.4 Light Sensor Module

Use FZB5610 ZigBee module as Light Sensor module,the pin attributes as shown as table 3-4.

Table 3-4 Pin attributes of ZigBee HA Light Sensor Module(Corresponding Type :FZB5610-LGT01-HA)

Pin Number	Name	I/O	Description
1	VDD	I	Power Input (+3.3V)
2	SCL	O	Light Sensor reads SCL signal of bus clock
3	DO	O	Relay control signal
4	GND.	I	Ground
5	Nc.		
6	DCT	I	Relay control feedback
7	Nc		
8	Status	O	Operating Status Indicator,it can connect to LED.H: ON,L:OFF;If LED keeps on,the model is not in the ZigBee Network;If LED is off,the model is in the ZigBee Network.In this case,each time the model sends a ZigBee data,LED flashes one time.When exiting the network,LED flashes quickly.It will not flash until LED keeps on,that means logout succeed.
9	Nc.		
10	FAC_RES ET	I	Factory reset button,press 5 seconds can reset to factory setting. Active low.
11	SDA	O	Light Sensor reads signal SDA of data bus
12	Nc.		
13	GND.		Ground
14	RESETn	I	System reset signal,active low
15	DC	I	DEBUG port,leave unconnected.
16	DD	I/O	DEBUG port,leave unconnected.
17	VDD	I	Power (+3.3V)

3.2.5 Infrared Human Body Sensor Module

Use FZB5610 ZigBee module as Infrared Human Body Sensor module,the pin attributes as shown as table 3-5.

Table 3-5 Pin attributes of ZigBee HA Infrared Human Body Sensor Module(Corresponding Type:FZB5610-BOT01-HA)

Pin number	Name	I/O	Description
1	VDD	I	Power (+3.3V) Infrared Human Body Sensor,active high,H:
2	DIN	I	Someone,L:No one.When designing,should configure pull-down resistor.
3	NC.	O	Output ,active low

Pin number	Name	I/O	Description
4	GND.		Ground
5	Nc.	O	Output ,active low
6	Nc.	O	Output ,active low
7	Nc	O	Output ,active low
8	Status	O	Operating Status Indicator,it can connect to LED.H : ON,L:OFF;if LED keeps on,the model is not in the ZigBee Network;if LED is off,the model is in the ZigBee Network.In this case,each time the model sends a ZigBee data,LED flashes one time.When exiting the network,LED flashes quickly.It will not flash until LED keeps on,that means logout succeed.
9	Nc.	O	Output ,active low
10	FAC_RESE T	I	Factory reset button,press 5 seconds can reset to factory setting. Active low.When designing,should configure pull-down resistor.
11	Nc.		Output ,active low
12	Nc.		Output ,active low
13	GND.		Ground
14	RESETn		System RESET signal,active low
15	DC	I	DEBUG port,leave unconnected
16	DD	I/O	DEBUG port,leave unconnected
17	VDD		Power (+3.3V)

3.2.6 Switch Module

Use FZB5610 ZigBee module as Switch module,the pin attributes as shown as table 3-6.

Table 3-6 Pin attributes of ZigBee HA Smart Switch Module(Corresponding Type : FZB5610-SC

H01-HA)			
Pin Number	Name	I/O	Description
1	VDD	I	Power (+3.3V)
2	DIN1	I	1# Switch input signal
3	DIN2	I	2# Switch input signal
4	GND.	I	Ground
5	DIN1_LED	O	
6	DIN2_LED	O	
7	DIN3_LED	O	DEMO Board leave unconnected.
8	Status	O	Operating Status Indicator,it can connect to LED.H:

Pin Number	Name	I/O	Description
			ON,L:OFF;If LED keeps on,the model is not in the ZigBee Network;If LED is off,the model is in the ZigBee Network.In this case,each time the model sends a ZigBee data,LED flashes one time.When exiting the network,LED flashes quickly.It will not flash until LED keeps on,that means logout succeed.
9	DIN4_LED	O	DEMO Board leave unconnected
10	FAC_RESET	I	Factory reset button,press 5 seconds can reset to factory setting. Active low.
11	DIN3	I	3# Switch input signal,DEMO Board leave unconnected
12	DIN4	I	4# Switch input signal,DEMO Board leave unconnected
13	GND.		Ground
14	RESETn	I	System RESET signal,active low.
15	DC	I	DEBUG port,leave unconnected
16	DD	I/O	DEBUG port,leave unconnected
17	VDD	I	Power (+3.3V)

3.2.7 Smart Plug Module

Use FZB5610 ZigBee module as Smart Plug module,the pin attributes as shown as table 3-7.

Table 3-7 Pin attributes of ZigBee HA socket control module(Corresponding Type :

FZB5610-SKT01-HA)			
Pin Number	Name	I/O	Description
1	VDD	I	Power (+3.3V)
2	DIN1	I	1# switch signal input
3	DIN2	I	2# switch signal input
4	GND.	I	Ground
5	DO1.	O	Relay control signal 1
6	DO2.	O	Relay control signal 2
7	DO3	O	Relay control signal 3
8	Status	O	Operating Status Indicator,it can connect to LED.H: ON,L:OFF;If LED keeps on,the model is

Pin Number	Name	I/O	Description
			not in the ZigBee Network;If LED is off,the model is in the ZigBee Network.In this case,each time the model sends a ZigBee data,LED flashes one time.When exiting the network,LED flashes quickly.It will not flash until LED keeps on,that means logout succeed.
9	DO4.	O	Relay control signal 4
10	FAC_RES ET	I	Factory reset button,press 5 seconds can reset to factory setting. Active low.
11	DIN3	I	3# Switch signal input
12	DIN4	I	4# Switch signal input
13	GND.		Ground
14	RESETn	I	System RESET signal,active low
15	DC	I	DEBUG port,leave unconnected
16	DD	I/O	DEBUG port,leave unconnected
17	VDD	I	Power (+3.3V)

3.2.8 Temperature and Humanity Sensor Module

Use FZB5610 ZigBee module as Temperature and Humanity Sensor module,the pin attributes as shown as table 3-8.

Table 3-8 Pin attributes of ZigBee HA Temperature and Humanity Sensor Module(Corresponding Type:FZB5610-THM02-HA)

Pin number	Name	I/O	Description
1	VDD	I	Power (+3.3V)
2	FAC_RES ET	I	Factory reset button,press 5 seconds can reset to factory setting. Active low.
3	Nc.		
4	GND.	I	Ground.
5	Nc.		
6	Nc.		
7	Nc.		
8	Status	O	Operating Status Indicator,it can connect to LED.H: ON,L:OFF;If LED keeps on,the model is not in the ZigBee Network;If LED is off,the model is in the ZigBee Network.In this case,each time the

Pin number	Name	I/O	Description
			model sends a ZigBee data,LED flashes one time.When exiting the network,LED flashes quickly.It will not flash until LED keeps on,that means logout succeed.
9	Tx	I	Serial port send Tx
10	Rx	O	Serial port receive Rx
11	Nc.		
12	Nc.		
13	GND.		Ground
14	RESETn	I	System RESET signal,active low
15	DC	I	DEBUG port,leave unconnected
16	DD	I/O	DEBUG port,leave unconnected
17	VDD	I	Power (+3.3V)

4 Reference Information

4.1 Electrical Schematic Diagram

The electrical schematic diagram of FZB5610 ZigBee module,which refers to FZB5610 schematic diagram.pdf.

4.2 Design Considerations

- ◆ The area below the antenna is unoccupied.
- ◆ The power of the module had better use 5V regulated power ,use a LDO that is suitable for RF application to supply power.
- ◆ Had better use double-sided board to design.
- ◆ IO port leave unconnected.
- ◆ The width of LED drive's layout is according to the actual current selection.
- ◆ The default state of output IO port is high-level,suggesting the users to add 1.2KΩ to pull-down resistor.
- ◆ RESET time is more than 200ms.See figure 4-1.

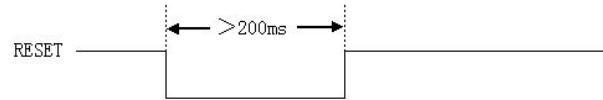

Figure 4-1 Reset time more than 200ms

5 IEEE 802.15.4

The IEEE 802.15.4 standard provides a worldwide standard for Personal Area Networks and short distance wireless networks for low data rate solutions with long battery life and low complexity. The standard defines a Physical layer (PHY) and a Medium Access Control layer (MAC). There are two active versions of the standard: IEEE 802.15.4-2003 and IEEE 802.15.4-2006 where the 2003 version is the basis for the ZigBee protocol. The typical applications are meter reading, home and building automation, industrial control and monitoring systems, wireless sensor networks, remote controls and consumer electronics.

The module complies with the IEEE 802.15.4 standard operating in the 2.45GHz band. It uses direct sequence spread spectrum (DSSS) with 2 Mc/s chip rate giving a raw data rate of 250kbit/s. 16 channels are available in the 2.45GHz band named channel 11-26 (channels 0-10 are reserved for use in the 868 and 915 MHz bands).

For more information on the standard, please consult www.ieee802.org/15/pub/TG4.html.

6 The ZigBee Protocol

The ZigBee Alliance is an association of companies working together to enable reliable, cost-effective, low-power, wirelessly networked, monitoring and control products based on an open global standard. The ZigBee Alliance is a rapidly growing, non-profit industry consortium of leading semiconductor manufacturers, technology providers, OEMs and end-users worldwide. Membership is open to all. The ZigBee Alliance, in collaboration with the IEEE is defining the network, security, and application layers above the IEEE

802.15.4 PHY and MAC layers. This cooperation has resulted in an easy-to-use, industry standard wireless network platform optimised for wireless monitoring and control applications.

The ZigBee standard defines a Network Layer and an Application Layer on top of IEEE.802.15.4. The network layer includes routing, security etc. While the application layer defines binding and other support for application.

The applications are specified in profiles to ensure multi-vendor interoperability. Current public profile includes:

- Smart Energy-SE(Profile for Smart Meter reading)
- Building Automation-CBA
- Home Automation-HA
- Health Care-HC
- Telecom Services-TA
- Remote Control - RF4CE

Manufacturer specific profiles can also be made.

The current version of the ZigBee standard is 2007. The standard defines two different stack feature sets:

- ZigBee Feature set
- ZigBee PRO feature set

In order to sell a product containing ZigBee technology, the seller must be a member (adaptor or higher) of the ZigBee alliance.

For more information about the ZigBee Alliance and the ZigBee standard, please consult www.zigbee.org.

7 Mechanical Drawings And Installation

The mechanical drawings and installation as shown as below.

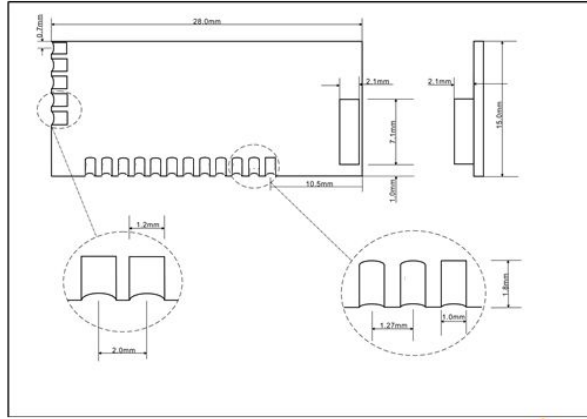

Figure 7-1 Mechanical drawing and installation

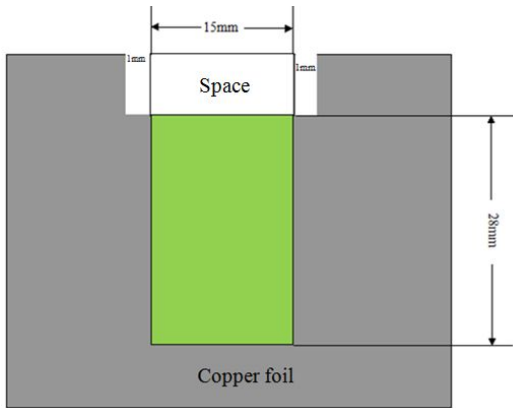

Figure 7-2 Installation 1

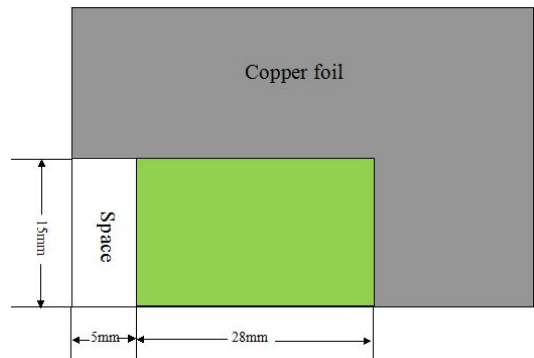

Figure 7-3 Installation 2

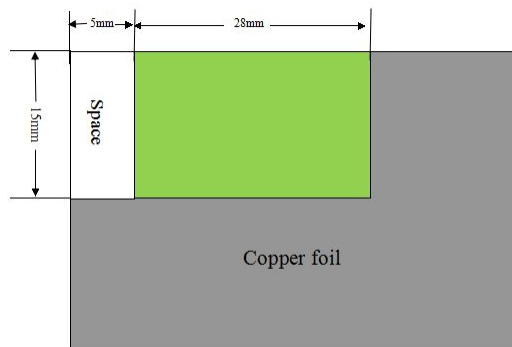

Figure 7-4 Installation 3

FCC compliance

This device complies with Part 15 of the FCC Rules.

Part Number	FCC ID
FZB5610	2AE8BFZB561011A

Operation is subject to the following two conditions: (1) this device may not cause harmful interference, and (2) this device must accept any interference received, including interference that may cause undesired operation.

Changes or modifications not expressly approved by the party responsible for compliance could void the user's authority to operate the equipment.

This device must be installed and used in strict accordance with the manufacturer's instructions as described in the user documentation that comes with the product.

The modules have been approved with the following external chip antenna.

Manufacturer	Part Number
WinWave Electronic Co., Ltd.	WAN8010F245M05

Warning for FZB5610: This device complies with FCC RF radiation exposure limits set forth for an uncontrolled environment. This device and its antenna(s) must not be co-located or operating in conjunction with any other antenna or transmitter.

The final end product must be labeled in a visible area with the following: Contains FCC ID: 2AE8BFZB561011A.

This module shall be integrated to the end product with a stable 3.3VDC power to this module through regulator circuit.

The OEM integrator is responsible for testing their end-product for any additional compliance requirements required with this module installed (for example, digital device emission, PC peripheral requirements, etc.).

COPYRIGHT STATEMENT

The copyright of the manual is belonged to Shenzhen Feibit Electronic Technology Co.,Ltd(simply “Feibit Technology”for short),and reserves all rights.Without the written consent of Feibit Technology,any company or individual can't copy the part or the whole content of the manual.

DISCLAIMER

Because of the version upgrading and other reasons,the content of the manual will update irregular.Unless with the other appointment,the manual will be only used as the user's guide,and all the statement,information and suggestion will not constitute any guarantee.

TRADEMARK STATEMENT



trademark of Shenzhen Feibit Electronic Technology Co.,Ltd.All other trademarks and registered trademarks are property of their respective owners.

Contact us

Shenzhen Feibit Electric Technology CO.,Ltd

Address: Room 505, Building A1, Lilang Software Park, No 31. Bulan Road, Nanwan Street, Longgang District, Shenzhen, China

Tel: 0755-36515299

Fax: 0755-83159815

E-mail: sales@feibit.com

Website: www.feibit.com