

FCC Test Report

Report No.: RF150904C32-4

FCC ID: 2AE79-2015DAP

Test Model: DP-X1/XDP-100R

Received Date: Sep. 04, 2015

Test Date: Sep. 08, 2015 ~ Sep. 15, 2015

Issued Date: Oct. 05, 2015

Applicant: Onkyo & Pioneer Innovations Corporation

Address: Onkyo Yaesu Bldg, 2-3-12, Yaesu, Chuo-Ku, Tokyo 104-0028, Japan

Issued By: Bureau Veritas Consumer Products Services (H.K.) Ltd., Taoyuan Branch

Lab Address: No. 47-2, 14th Ling, Chia Pau Vil., Lin Kou Dist., New Taipei City, Taiwan
(R.O.C)

Test Location (1): No. 19, Hwa Ya 2nd Rd, Wen Hwa Tsuen, Kwei Shan Hsiang, Taoyuan
Hsien 333, Taiwan, R.O.C.



This report is for your exclusive use. Any copying or replication of this report to or for any other person or entity, or use of our name or trademark, is permitted only with our prior written permission. This report sets forth our findings solely with respect to the test samples identified herein. The results set forth in this report are not indicative or representative of the quality or characteristics of the lot from which a test sample was taken or any similar or identical product unless specifically and expressly noted. Our report includes all of the tests requested by you and the results thereof based upon the information that you provided to us. You have 60 days from date of issuance of this report to notify us of any material error or omission caused by our negligence, provided, however, that such notice shall be in writing and shall specifically address the issue you wish to raise. A failure to raise such issue within the prescribed time shall constitute your unqualified acceptance of the completeness of this report, the tests conducted and the correctness of the report contents. Unless specific mention, the uncertainty of measurement has been explicitly taken into account to declare the compliance or non-compliance to the specification. The report must not be used by the client to claim product certification, approval, or endorsement by TAF or any government agencies.

Table of Contents

Release Control Record	4
1 Certificate of Conformity	5
2 Summary of Test Results	6
2.1 Measurement Uncertainty	6
2.2 Modification Record	6
3 General Information	7
3.1 General Description of EUT	7
3.2 Description of Test Modes	9
3.2.1 Test Mode Applicability and Tested Channel Detail	11
3.3 Duty Cycle of Test Signal	14
3.4 Description of Support Units	18
3.4.1 Configuration of System under Test	18
3.5 General Description of Applied Standards	19
4 Test Types and Results	20
4.1 Radiated Emission and Bandedge Measurement	20
4.1.1 Limits of Radiated Emission and Bandedge Measurement	20
4.1.2 Limits of Unwanted Emission Out of The Restricted Bands	20
4.1.3 Test Instruments	21
4.1.4 Test Procedures	22
4.1.5 Deviation from Test Standard	22
4.1.6 Test Set Up	23
4.1.7 EUT Operating Conditions	23
4.1.8 Test Results	24
4.2 Conducted Emission Measurement	74
4.2.1 Limits of Conducted Emission Measurement	74
4.2.2 Test Instruments	74
4.2.3 Test Procedures	75
4.2.4 Deviation from Test Standard	75
4.2.5 Test Setup	75
4.2.6 EUT Operating Conditions	75
4.2.7 Test Results	76
4.3 Transmit Power Measurement	80
4.3.1 Limits of Transmit Power Measurement	80
4.3.2 Test Setup	80
4.3.3 Test Instruments	81
4.3.4 Test Procedure	81
4.3.5 Deviation from Test Standard	81
4.3.6 EUT Operating Conditions	81
4.3.7 Test Result	82
4.4 Peak Power Spectral Density Measurement	87
4.4.1 Limits of Peak Power Spectral Density Measurement	87
4.4.2 Test Setup	87
4.4.3 Test Instruments	87
4.4.4 Test Procedures	88
4.4.5 Deviation from Test Standard	88
4.4.6 EUT Operating Conditions	88
4.4.7 Test Results	89
4.5 Frequency Stability	94
4.5.1 Limit of Frequency Stability Measurement	94
4.5.2 Test Setup	94
4.5.3 Test Instruments	94
4.5.4 Test Procedure	94
4.5.5 Deviation from Test Standard	94



4.5.6 EUT Operating Condition	94
4.5.7 Test Results	95
4.6 6dB Bandwidth Measurement.....	96
4.6.1 Limits of 6dB Bandwidth Measurement.....	96
4.6.2 Test Setup.....	96
4.6.3 Test Instruments	96
4.6.4 Test Procedure	96
4.6.5 Deviation from Test Standard	96
4.6.6 EUT Operating Condition	96
4.6.7 Test Results	97
5 Pictures of Test Arrangements.....	99
Appendix – Information on the Testing Laboratories	100



Release Control Record

Issue No.	Description	Date Issued
RF150904C32-4	Original Release	Oct. 05, 2015



1 Certificate of Conformity

Product: Digital Audio Player
Brand: ONKYO/PIONEER
Test Model: DP-X1/XDP-100R
Sample Status: Identical Prototype
Applicant: Onkyo & Pioneer Innovations Corporation
Test Date: Sep. 08, 2015 ~ Sep. 15, 2015
Standards: 47 CFR FCC Part 15, Subpart E (Section 15.407)
ANSI C63.10:2013

The above equipment has been tested by **Bureau Veritas Consumer Products Services (H.K.) Ltd., Taoyuan Branch**, and found compliance with the requirement of the above standards. The test record, data evaluation & Equipment Under Test (EUT) configurations represented herein are true and accurate accounts of the measurements of the sample's EMC characteristics under the conditions specified in this report.

Prepared by : Ivonne Wu , **Date:** Oct. 05, 2015
Ivonne Wu / Supervisor

Approved by : Kay Wu , **Date:** Oct. 05, 2015
Kay Wu / Supervisor

2 Summary of Test Results

47 CFR FCC Part 15, Subpart E (SECTION 15.407)			
FCC Clause	Test Item	Result	Remarks
15.407(b)(6)	AC Power Conducted Emissions	PASS	Meet the requirement of limit. Minimum passing margin is -10.02dB at 0.18600MHz.
15.407(b)(1/2/3/4/6)	Radiated Emissions & Band Edge Measurement	PASS	Meet the requirement of limit. Minimum passing margin is -2.98dB at 5714MHz.
15.407(a)(1/2/3)	Max Average Transmit Power	PASS	Meet the requirement of limit.
15.407(a)(1/2/3)	Peak Power Spectral Density	PASS	Meet the requirement of limit.
15.407(e)	6dB bandwidth	PASS	Meet the requirement of limit. (U-NII-3 Band only)
15.407(g)	Frequency Stability	PASS	Meet the requirement of limit.
15.203	Antenna Requirement	PASS	No antenna connector is used.

2.1 Measurement Uncertainty

Where relevant, the following measurement uncertainty levels have been estimated for tests performed on the EUT as specified in CISPR 16-4-2:

Measurement	Frequency	Expanded Uncertainty (k=2) (±)
Conducted Emissions at mains ports	150kHz ~ 30MHz	2.44 dB
Radiated Emissions up to 1 GHz	30MHz ~ 200MHz	2.93 dB
	200MHz ~ 1000MHz	2.95 dB
Radiated Emissions above 1 GHz	1GHz ~ 18GHz	2.26 dB
	18GHz ~ 40GHz	1.94 dB

2.2 Modification Record

There were no modifications required for compliance.

3 General Information

3.1 General Description of EUT

Product	Digital Audio Player
Brand	ONKYO/PIONEER
Test Model	DP-X1/XDP-100R
Status of EUT	Identical Prototype
Power Supply Rating	5.0Vdc (Host equipment) 3.8Vdc (Li-ion battery)
Modulation Type	256QAM, 64QAM, 16QAM, QPSK, BPSK
Modulation Technology	OFDM
Transfer Rate	802.11a: 54.0/ 48.0/ 36.0/ 24.0/ 18.0/ 12.0/ 9.0/ 6.0Mbps 802.11n: up to MCS7 802.11ac: up to V9
Operating Frequency	5180 ~ 5240MHz, 5260 ~ 5320MHz, 5500 ~ 5700MHz, 5745 ~ 5825MHz
Number of Channel	5180 ~ 5240MHz: 4 for 802.11a, 802.11n (20MHz) 2 for 802.11n (40MHz) 1 for 802.11ac (80MHz) 5260 ~ 5320MHz: 4 for 802.11a, 802.11n (20MHz) 2 for 802.11n (40MHz) 1 for 802.11ac (80MHz) 5500 ~ 5700MHz: 8 for 802.11a, 802.11n (20MHz) 3 for 802.11n (40MHz) 2 for 802.11ac (80MHz) 5745 ~ 5825MHz: 5 for 802.11a, 802.11n (20MHz) 2 for 802.11n (40MHz) 1 for 802.11ac (80MHz)
Output Power	32.06mW for 5180 ~ 5240MHz 32.14mW for 5260 ~ 5320MHz 32.28mW for 5500 ~ 5700MHz 32.28mW for 5745 ~ 5825MHz
Antenna Type	ONKYO: 5180 ~ 5240MHz: PIFA antenna with -2.0 dBi gain 5260 ~ 5320MHz: PIFA antenna with -2.1 dBi gain 5500 ~ 5700MHz: PIFA antenna with -1.4 dBi gain 5745 ~ 5825MHz: PIFA antenna with -1.3 dBi gain PIONEER: 5180 ~ 5240MHz: PIFA antenna with -1.8 dBi gain 5260 ~ 5320MHz: PIFA antenna with -0.8 dBi gain 5500 ~ 5700MHz: PIFA antenna with 0.7 dBi gain 5745 ~ 5825MHz: PIFA antenna with 1.3 dBi gain
Antenna Connector	N/A
Accessory Device	Refer to Note as below
Data Cable Supplied	Refer to Note as below

Note:

1. All models are listed as below.

Brand	Model	Description
ONKYO	DP-X1	All models are electrically identical, different model names and brand names are for marketing purpose.
PIONEER	XDP-100R	

- ✧ EUT with brand PIONEER was chosen as the main test, and only the worst case of main test result was verified for EUT with brand ONKYO.

2. The EUT contains following accessory devices.

Product	Brand	Model	Description
Battery	TCL	PR-335367G	3.8Vdc, 1630mAh
USB Cable	N/A	N/A	0.9m shielded cable w/o core
WLAN/BT Module	Intel	8260 NGW	--

3. The above EUT information is declared by manufacturer and for more detailed features description, please refer to the manufacturer's specifications or user's manual.

3.2 Description of Test Modes

FOR 5180 ~ 5240MHz

4 channels are provided for 802.11a, 802.11n (20MHz):

Channel	Frequency	Channel	Frequency
36	5180 MHz	44	5220 MHz
40	5200 MHz	48	5240 MHz

2 channels are provided for 802.11n (40MHz):

Channel	Frequency	Channel	Frequency
38	5190 MHz	46	5230 MHz

1 channel is provided for 802.11ac (80MHz):

Channel	Frequency
42	5210MHz

FOR 5260 ~ 5320MHz

4 channels are provided for 802.11a, 802.11n (20MHz):

Channel	Frequency	Channel	Frequency
52	5260 MHz	60	5300 MHz
56	5280 MHz	64	5320 MHz

2 channels are provided for 802.11n (40MHz):

Channel	Frequency	Channel	Frequency
54	5270 MHz	62	5310 MHz

1 channel is provided for 802.11ac (80MHz):

Channel	Frequency
58	5290MHz

FOR 5500 ~ 5700MHz

11 channels are provided for 802.11a, 802.11n (20MHz):

Channel	Frequency	Channel	Frequency
100	5500 MHz	124	5620 MHz
104	5520 MHz	128	5640 MHz
108	5540 MHz	132	5660 MHz
112	5560 MHz	136	5680 MHz
116	5580 MHz	140	5700 MHz
120	5600 MHz		

5 channels are provided for 802.11n (40MHz):

Channel	Frequency	Channel	Frequency
102	5510 MHz	126	5630 MHz
110	5550 MHz	134	5670 MHz
118	5590 MHz		

2 channels are provided for 802.11ac (80MHz):

Channel	Frequency	Channel	Frequency
106	5530MHz	122	5610 MHz

FOR 5745 ~ 5825MHz:

5 channels are provided for 802.11a, 802.11n (20MHz):

Channel	Frequency	Channel	Frequency
149	5745MHz	161	5805MHz
153	5765MHz	165	5825MHz
157	5785MHz		

2 channels are provided for 802.11n (40MHz):

Channel	Frequency	Channel	Frequency
151	5755MHz	159	5795MHz

1 channel is provided for 802.11ac (80MHz):

Channel	Frequency
155	5775MHz

3.2.1 Test Mode Applicability and Tested Channel Detail

EUT Configure Mode	Applicable To				Description
	RE \geq 1G	RE $<$ 1G	PLC	APCM	
A	√	√	√	√	EUT with brand PIONEER
B	√	√	√	-	EUT with brand ONKYO

Where **RE \geq 1G**: Radiated Emission above 1GHz **RE $<$ 1G**: Radiated Emission below 1GHz
PLC: Power Line Conducted Emission **APCM**: Antenna Port Conducted Measurement

NOTE:

1. The EUT had been pre-tested on the positioned of each 3 axis. The worst case was found when positioned on **Y-plane** for 5180-5240MHz & 5260-5320MHz & 5745-5825MHz and **Z-plane** for 5500-5700MHz.
2. "-" means no effect.

Radiated Emission Test (Above 1GHz):

- Pre-Scan has been conducted to determine the worst-case mode from all possible combinations between available modulations, data rates and antenna ports (if EUT with antenna diversity architecture).
- Following channel(s) was (were) selected for the final test as listed below.

EUT Configure Mode	Mode	Frequency Band (MHz)	Available Channel	Tested Channel	Modulation Technology	Modulation Type	Data Rate (Mbps)
A	802.11a	5180-5240	36 to 48	36, 40, 48	OFDM	BPSK	6.0
	802.11n (20MHz)		36 to 48	36, 40, 48	OFDM	BPSK	MCS0
	802.11n (40MHz)		38 to 46	38, 46	OFDM	BPSK	MCS0
	802.11ac (80MHz)		42	42	OFDM	BPSK	V0
	802.11a	5260-5320	52 to 64	52, 60, 64	OFDM	BPSK	6.0
	802.11n (20MHz)		52 to 64	52, 60, 64	OFDM	BPSK	MCS0
	802.11n (40MHz)		54 to 62	54, 62	OFDM	BPSK	MCS0
	802.11ac (80MHz)		58	58	OFDM	BPSK	V0
	802.11a	5500-5700	100 to 140	100, 116, 140	OFDM	BPSK	6.0
	802.11n (20MHz)		100 to 140	100, 116, 140	OFDM	BPSK	MCS0
	802.11n (40MHz)		102 to 134	102, 110, 134	OFDM	BPSK	MCS0
	802.11ac (80MHz)		106 to 122	106, 122	OFDM	BPSK	V0
	802.11a	5745-5825	149 to 165	149, 157, 165	OFDM	BPSK	6.0
	802.11n (20MHz)		149 to 165	149, 157, 165	OFDM	BPSK	MCS0
	802.11n (40MHz)		151 to 159	151, 159	OFDM	BPSK	MCS0
	802.11ac (80MHz)		155	155	OFDM	BPSK	V0
B	802.11ac (80MHz)	5180-5240	42	42	OFDM	BPSK	V0
	802.11ac (80MHz)	5260-5320	58	58	OFDM	BPSK	V0
	802.11a	5500-5700	100 to 140	140	OFDM	BPSK	6.0
	802.11ac (80MHz)	5745-5825	155	155	OFDM	BPSK	V0

Radiated Emission Test (Below 1GHz):

- Pre-Scan has been conducted to determine the worst-case mode from all possible combinations between available modulations, data rates and antenna ports (if EUT with antenna diversity architecture).
- Following channel(s) was (were) selected for the final test as listed below.

EUT Configure Mode	Mode	Frequency Band (MHz)	Available Channel	Tested Channel	Modulation Technology	Modulation Type	Data Rate (Mbps)
-	802.11ac (80MHz)	5180-5240	42	42	OFDM	BPSK	V0
-	802.11ac (80MHz)	5260-5320	58	58	OFDM	BPSK	V0
-	802.11a	5500-5700	100 to 140	140	OFDM	BPSK	6.0
	802.11ac (80MHz)	5745-5825	155	155	OFDM	BPSK	V0

Power Line Conducted Emission Test:

- Pre-Scan has been conducted to determine the worst-case mode from all possible combinations between available modulations, data rates and antenna ports (if EUT with antenna diversity architecture).
- Following channel(s) was (were) selected for the final test as listed below.

EUT Configure Mode	Mode	Frequency Band (MHz)	Available Channel	Tested Channel	Modulation Technology	Modulation Type	Data Rate (Mbps)
A, B	802.11ac	5745-5825	155	155	OFDM	BPSK	V0

Antenna Port Conducted Measurement:

- This item includes all test value of each mode, but only includes spectrum plot of worst value of each mode.
- Pre-Scan has been conducted to determine the worst-case mode from all possible combinations between available modulations, data rates and antenna ports (if EUT with antenna diversity architecture).
- Following channel(s) was (were) selected for the final test as listed below.

EUT Configure Mode	Mode	Frequency Band (MHz)	Available Channel	Tested Channel	Modulation Technology	Modulation Type	Data Rate (Mbps)
A	802.11a	5180-5240	36 to 48	36, 40, 48	OFDM	BPSK	6.0
	802.11n (20MHz)		36 to 48	36, 40, 48	OFDM	BPSK	MCS0
	802.11n (40MHz)		38 to 46	38, 46	OFDM	BPSK	MCS0
	802.11ac (80MHz)		42	42	OFDM	BPSK	V0
	802.11a	5260-5320	52 to 64	52, 60, 64	OFDM	BPSK	6.0
	802.11n (20MHz)		52 to 64	52, 60, 64	OFDM	BPSK	MCS0
	802.11n (40MHz)		54 to 62	54, 62	OFDM	BPSK	MCS0
	802.11ac (80MHz)		58	58	OFDM	BPSK	V0
	802.11a	5500-5700	100 to 140	100, 116, 140	OFDM	BPSK	6.0
	802.11n (20MHz)		100 to 140	100, 116, 140	OFDM	BPSK	MCS0
	802.11n (40MHz)		102 to 134	102, 110, 134	OFDM	BPSK	MCS0
	802.11ac (80MHz)		106 to 122	106, 122	OFDM	BPSK	V0
	802.11a	5745-5825	149 to 165	149, 157, 165	OFDM	BPSK	6.0
	802.11n (20MHz)		149 to 165	149, 157, 165	OFDM	BPSK	MCS0
	802.11n (40MHz)		151 to 159	151, 159	OFDM	BPSK	MCS0
	802.11ac (80MHz)		155	155	OFDM	BPSK	V0



Test Condition:

Applicable To	Environmental Conditions	Input Power	Tested by
RE \geq 1G	25deg. C, 65%RH	120Vac, 60Hz (System)	Gavin Wu
RE<1G	25deg. C, 65%RH	120Vac, 60Hz (System)	Gavin Wu
PLC	25deg. C, 65%RH	120Vac, 60Hz (System)	Toby Tian
APCM	25deg. C, 65%RH	3.8Vdc	Luke Chen

3.3 Duty Cycle of Test Signal

MODULATION TYPE: BPSK

Duty cycle of test signal is < 98%, duty factor is required.

802.11a: Duty cycle = 1.042/1.242 = 0.839, Duty factor = $10 * \log(1/0.839) = 0.76$

802.11n (20MHz): Duty cycle = 977.56/1169.87 = 0.836, Duty factor = $10 * \log(1/0.836) = 0.78$

802.11n (40MHz): Duty cycle = 488.78/689.10 = 0.709, Duty factor = $10 * \log(1/0.709) = 1.49$

802.11ac (80MHz): Duty cycle = 248.40/448.72 = 0.554, Duty factor = $10 * \log(1/0.554) = 2.57$

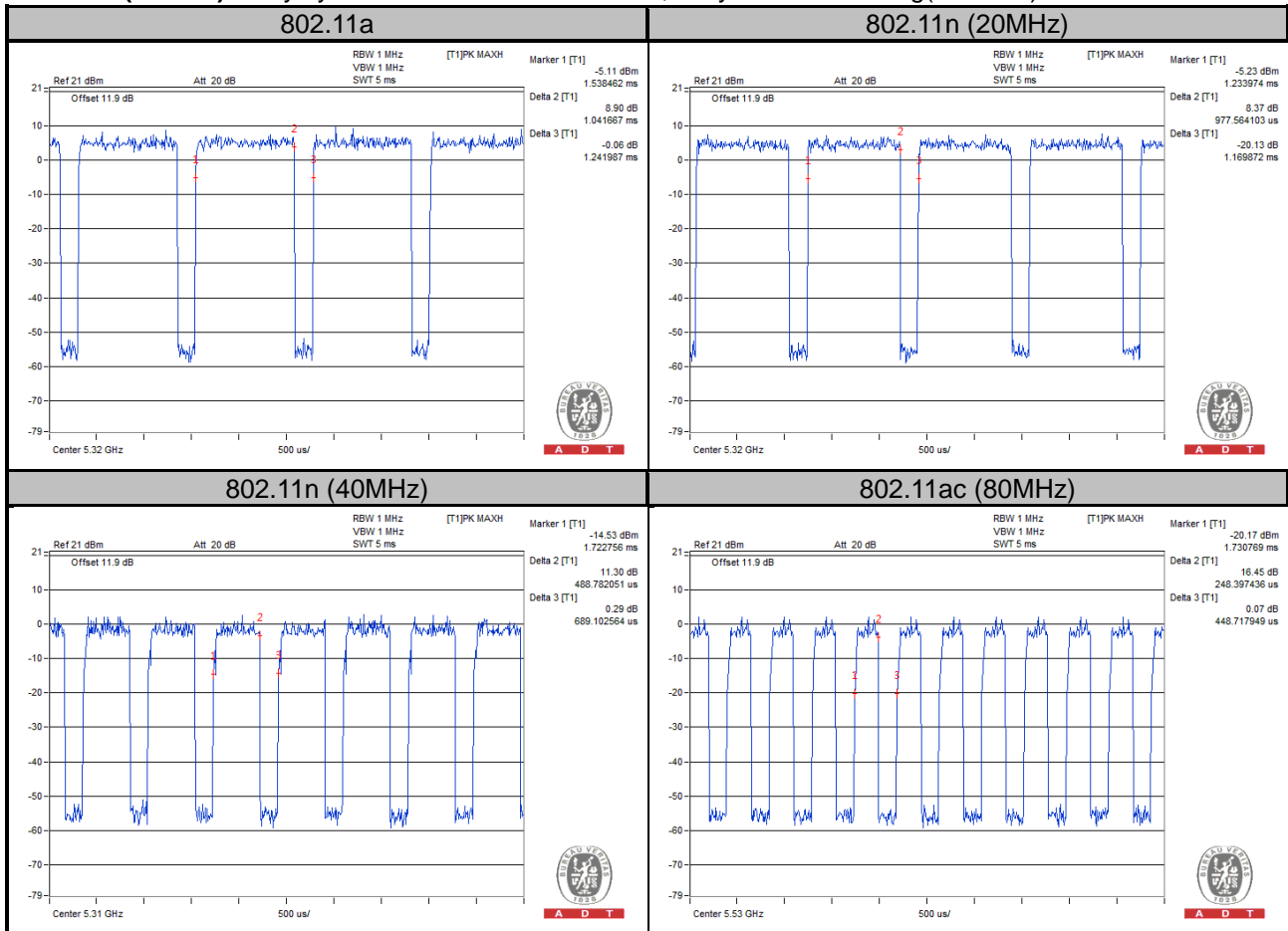

MODULATION TYPE: QPSK

Duty cycle of test signal is < 98%, duty factor is required.

802.11a: Duty cycle = $541.67/735.58 = 0.736$, Duty factor = $10 * \log(1/0.736) = 1.33$

802.11n (20MHz): Duty cycle = $516.02/714.74 = 0.722$, Duty factor = $10 * \log(1/0.722) = 1.41$

802.11n (40MHz): Duty cycle = $267.63/463.14 = 0.578$, Duty factor = $10 * \log(1/0.578) = 2.38$

802.11ac (80MHz): Duty cycle = $142.63/347.76 = 0.410$, Duty factor = $10 * \log(1/0.410) = 3.87$

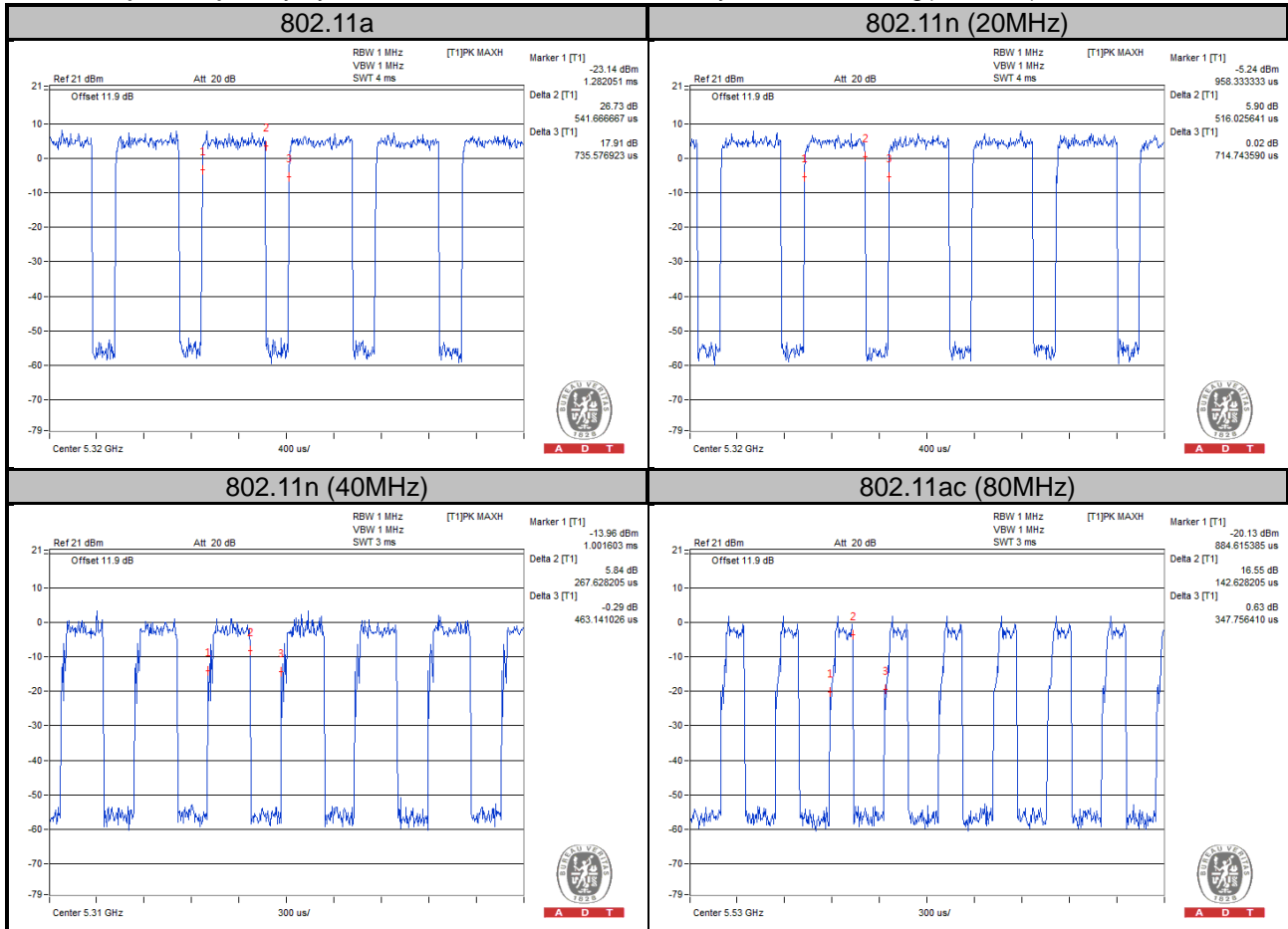

MODULATION TYPE: 16QAM

Duty cycle of test signal is < 98%, duty factor is required.

802.11a: Duty cycle = 278.85/474.36 = 0.588, Duty factor = $10 * \log(1/0.588) = 2.31$

802.11n (20MHz): Duty cycle = 275.64/469.55 = 0.587, Duty factor = $10 * \log(1/0.587) = 2.31$

802.11n (40MHz): Duty cycle = 173.08/375.00 = 0.462, Duty factor = $10 * \log(1/0.462) = 3.36$

802.11ac (80MHz): Duty cycle = 92.95/294.87 = 0.315, Duty factor = $10 * \log(1/0.315) = 5.01$

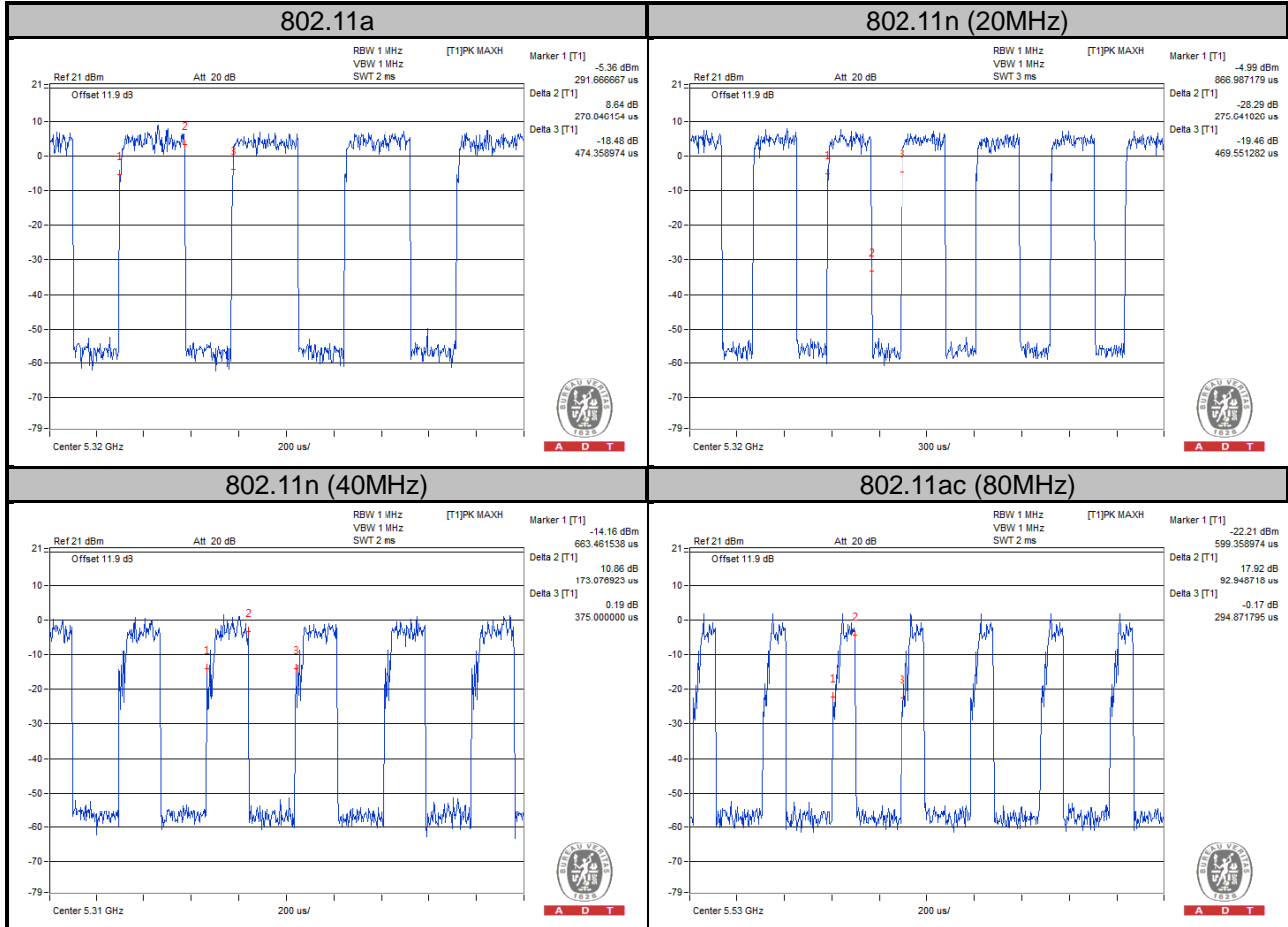

MODULATION TYPE: 64QAM

Duty cycle of test signal is < 98%, duty factor is required.

802.11a: Duty cycle = $150.64/349.36 = 0.431$, Duty factor = $10 * \log(1/0.431) = 3.65$

802.11n (20MHz): Duty cycle = $157.05/357.37 = 0.439$, Duty factor = $10 * \log(1/0.439) = 3.57$

802.11n (40MHz): Duty cycle = $108.97/304.49 = 0.358$, Duty factor = $10 * \log(1/0.358) = 4.46$

802.11ac (80MHz): Duty cycle = $70.51/269.23 = 0.262$, Duty factor = $10 * \log(1/0.262) = 5.82$

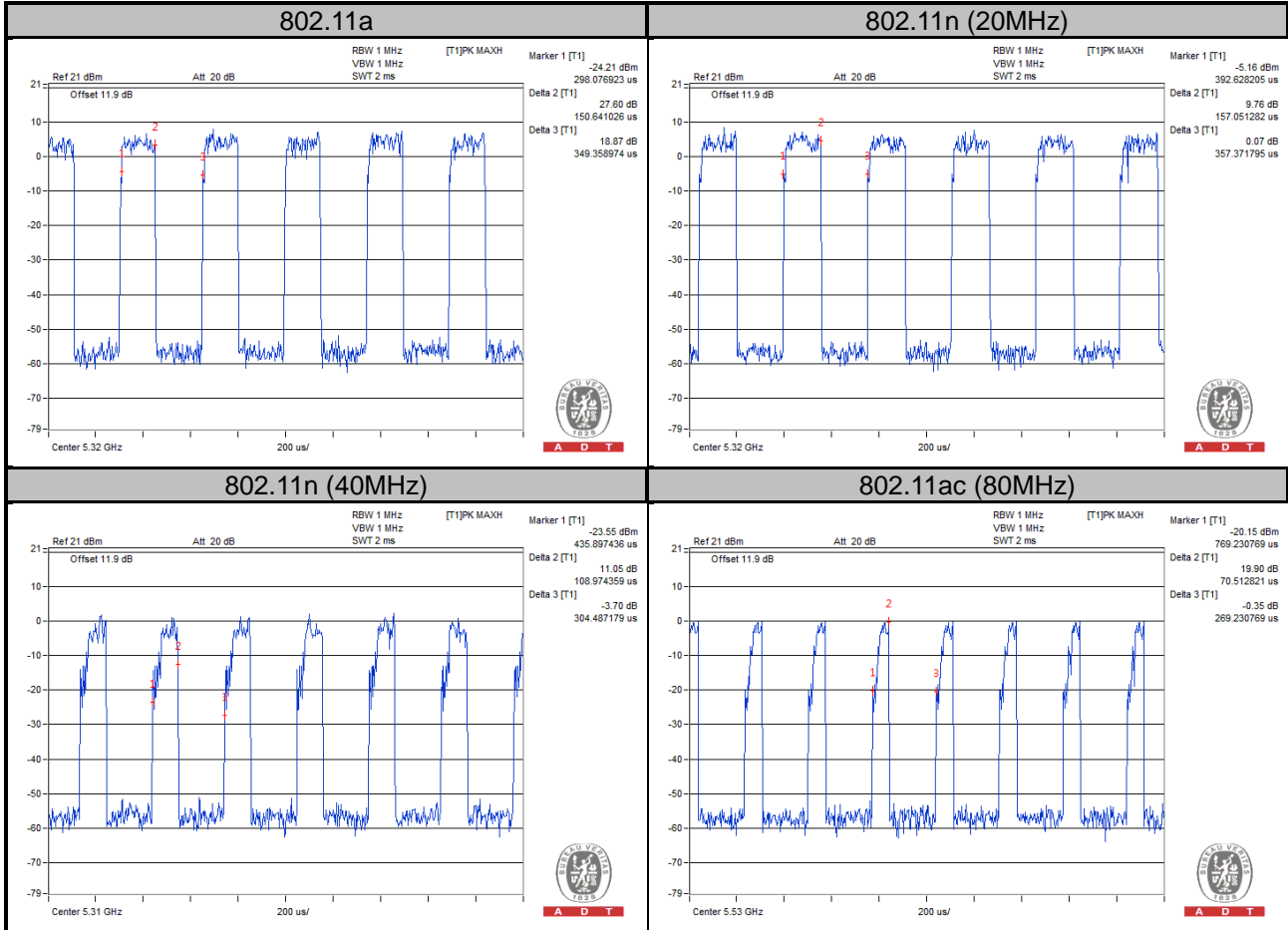

MODULATION TYPE: 256QAM

Duty cycle of test signal is < 98%, duty factor is required.

802.11ac (80MHz): Duty cycle = $62.50/261.22 = 0.239$, Duty factor = $10 * \log(1/0.239) = 6.21$

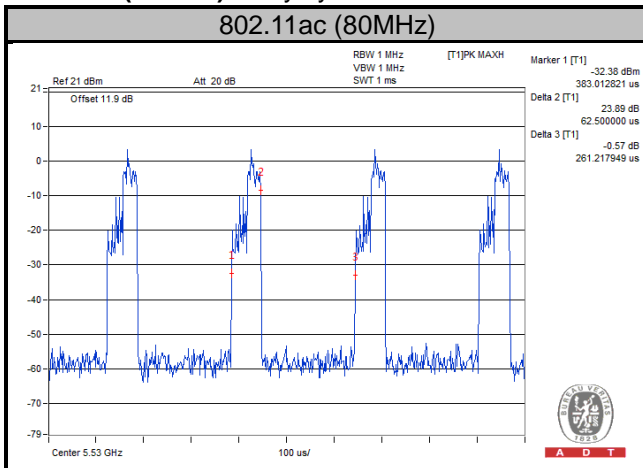

3.4 Description of Support Units

The EUT has been tested as an independent unit together with other necessary accessories or support units. The following support units or accessories were used to form a representative test configuration during the tests.

No.	Product	Brand	Model No.	Serial No.	FCC ID
1.	Notebook	DELL	Inspiron 14R	9LRKKW1	N/A
2.	Earphone	N/A	FK-130102	N/A	N/A

No.	Signal Cable Description Of The Above Support Units
1.	0.9m shielded USB cable w/o core
2.	N/A

Note:

1. All power cords of the above support units are non-shielded (1.8m).

3.4.1 Configuration of System under Test

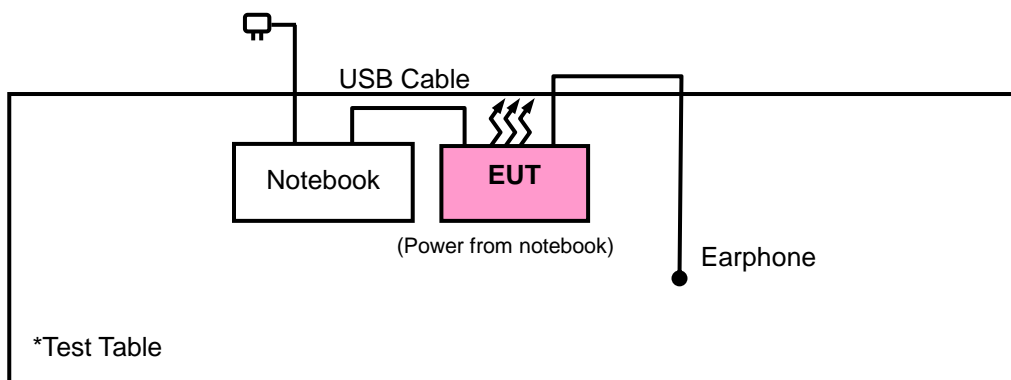

3.5 General Description of Applied Standards

The EUT is a RF Product. According to the specifications of the manufacturer, it must comply with the requirements of the following standards:

FCC Part 15, Subpart E (15.407)

789033 D02 General UNII Test Procedures New Rules v01

644545 D01 Guidance for IEEE 802 11ac v01r02

ANSI C63.10-2013

All test items have been performed and recorded as per the above standards.

NOTE: The EUT has been verified to comply with the requirements of FCC Part 15, Subpart B, Class B (DoC).
The test report has been issued separately.

4 Test Types and Results

4.1 Radiated Emission and Bandedge Measurement

4.1.1 Limits of Radiated Emission and Bandedge Measurement

Radiated emissions which fall in the restricted bands must comply with the radiated emission limits specified as below table. Other emissions shall be at least 20dB below the highest level of the desired power:

Frequencies (MHz)	Field Strength (microvolts/meter)	Measurement Distance (meters)
0.009 ~ 0.490	2400/F(kHz)	300
0.490 ~ 1.705	24000/F(kHz)	30
1.705 ~ 30.0	30	30
30 ~ 88	100	3
88 ~ 216	150	3
216 ~ 960	200	3
Above 960	500	3

NOTE:

1. The lower limit shall apply at the transition frequencies.
2. Emission level (dBuV/m) = 20 log Emission level (uV/m).
3. For frequencies above 1000MHz, the field strength limits are based on average detector, however, the peak field strength of any emission shall not exceed the maximum permitted average limits, specified above by more than 20dB under any condition of modulation.

4.1.2 Limits of Unwanted Emission Out of The Restricted Bands

Applicable To	Limit	
789033 D02 General UNII Test Procedures New Rules v01	Field Strength AT 3m	
	PK:74 (dBµV/m)	AV:54 (dBµV/m)
Applicable To	EIRP Limit	Equivalent Field Strength At 3m
15.407(b)(1)	PK:-27 (dBm/MHz)	PK:68.2(dBµV/m)
15.407(b)(2)		
15.407(b)(3)		
15.407(b)(4)	PK:-27 (dBm/MHz) ^{*1} PK:-17 (dBm/MHz) ^{*2}	PK: 68.2(dBµV/m) ^{*1} PK:78.2 (dBµV/m) ^{*2}

NOTE: ^{*1} beyond 10MHz of the band edge ^{*2} within 10 MHz of band edge

The following formula is used to convert the equipment isotropic radiated power (eirp) to field strength:

$$E = \frac{1000000\sqrt{30P}}{3} \mu\text{V/m, where P is the eirp (Watts).}$$



4.1.3 Test Instruments

Description & Manufacturer	Model No.	Serial No.	Date of Calibration	Due Date of Calibration
Test Receiver Agilent	N9038A	MY51210203	Jan. 21, 2015	Jan. 21, 2016
Spectrum Analyzer Agilent	N9010A	MY52220314	Sep. 03, 2015	Sep. 02, 2016
Spectrum Analyzer ROHDE & SCHWARZ	FSU43	101261	Dec. 10, 2014	Dec. 09, 2015
BILOG Antenna SCHWARZBECK	VULB9168	9168-472	Feb. 04, 2015	Feb. 04, 2016
HORN Antenna SCHWARZBECK	BBHA 9120 D	9120D-969	Feb. 09, 2015	Feb. 09, 2016
HORN Antenna SCHWARZBECK	BBHA 9170	9170-480	Feb. 04, 2015	Feb. 04, 2016
Loop Antenna	EM-6879	269	Jul. 31, 2015	Jul. 30, 2016
Preamplifier EMCI	EMC 012645	980115	Dec. 12, 2014	Dec. 11, 2015
Preamplifier EMCI	EMC 184045	980116	Jan. 09, 2015	Jan. 08, 2016
Preamplifier EMCI	EMC 330H	980112	Dec. 27, 2014	Dec. 26, 2015
Power Meter Anritsu	ML2495A	1012010	Aug. 21, 2015	Aug. 20, 2016
Power Sensor Anritsu	MA2411B	1315050	Aug. 21, 2015	Aug. 20, 2016
RF signal cable HUBER+SUHNNER	SUCOFLEX 104	309219/4 2950114	Oct. 18, 2014	Oct. 17, 2015
RF signal cable HUBER+SUHNNER	SUCOFLEX 104	250130/4	Oct. 18, 2014	Oct. 17, 2015
RF Coaxial Cable Worken	8D-FB	Cable-Ch10-01	Nov. 07, 2014	Nov. 06, 2015
Software BV ADT	E3 6.120103	NA	NA	NA
Antenna Tower MF	MFA-440H	NA	NA	NA
Turn Table MF	MFT-201SS	NA	NA	NA
Antenna Tower & Turn Table Controller MF	MF-7802	NA	NA	NA

- Note: 1. The calibration interval of the above test instruments is 12 months and the calibrations are traceable to NML/ROC and NIST/USA.
2. The test was performed in HwaYa Chamber 10.
3. The horn antenna and preamplifier (model: EMC 184045) are used only for the measurement of emission frequency above 1GHz if tested.
4. The FCC Site Registration No. is 690701.
5. The IC Site Registration No. is IC7450F-10.

4.1.4 Test Procedures

- a. The EUT was placed on the top of a rotating table 0.8 meters (for below 1GHz) / 1.5 meters (for above 1GHz) above the ground at 3 meter chamber room for test. The table was rotated 360 degrees to determine the position of the highest radiation.
- b. The EUT was set 3 meters away from the interference-receiving antenna, which was mounted on the top of a variable-height antenna tower.
- c. The height of antenna is varied from one meter to four meters above the ground to determine the maximum value of the field strength. Both horizontal and vertical polarizations of the antenna are set to make the measurement.
- d. For each suspected emission, the EUT was arranged to its worst case and then the antenna was tuned to heights from 1 meter to 4 meters and the rotatable table was turned from 0 degrees to 360 degrees to find the maximum reading.
- e. The test-receiver system was set to quasi-peak detect function and specified bandwidth with maximum hold mode when the test frequency is below 1 GHz.
- f. The test-receiver system was set to peak and average detect function and specified bandwidth with maximum hold mode when the test frequency is above 1 GHz. If the peak reading value also meets average limit, measurement with the average detector is unnecessary.

Note:

1. The resolution bandwidth and video bandwidth of test receiver/spectrum analyzer is 120kHz for Quasi-peak detection (QP) at frequency below 1GHz.
2. The resolution bandwidth of test receiver/spectrum analyzer is 1 MHz and the video bandwidth is 3 MHz for Peak detection (PK) at frequency above 1GHz.
3. The resolution bandwidth of test receiver/spectrum analyzer is 1MHz and the video bandwidth is 3MHz for RMS Average (Duty cycle < 98%) for Average detection (AV) at frequency above 1GHz, then the measurement results was added to a correction factor ($10 \log(1/\text{duty cycle})$).
4. The resolution bandwidth of test receiver/spectrum analyzer is 1MHz and the video bandwidth is 10Hz (Duty cycle $\geq 98\%$) for Average detection (AV) at frequency above 1GHz.
5. All modes of operation were investigated and the worst-case emissions are reported.

4.1.5 Deviation from Test Standard

No deviation.

4.1.6 Test Set Up

<Frequency Range below 1GHz>

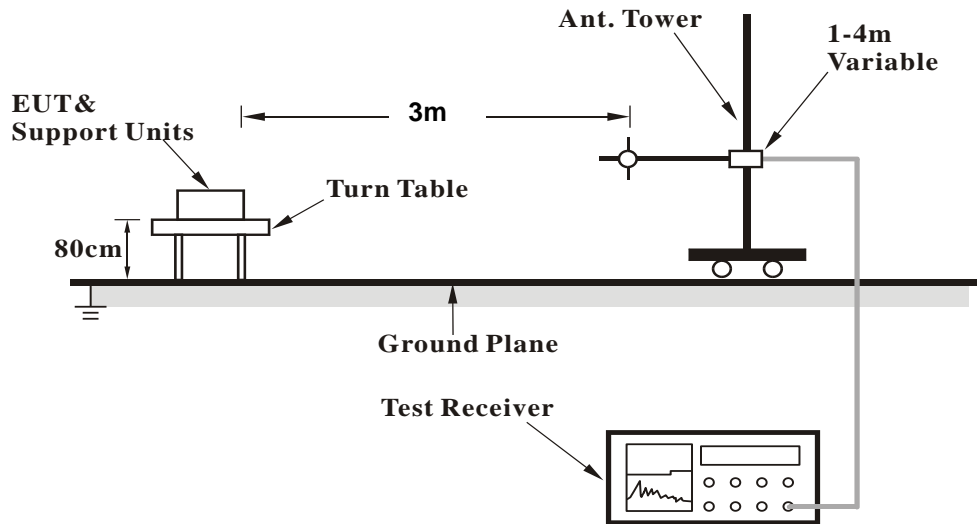

<Frequency Range above 1GHz>

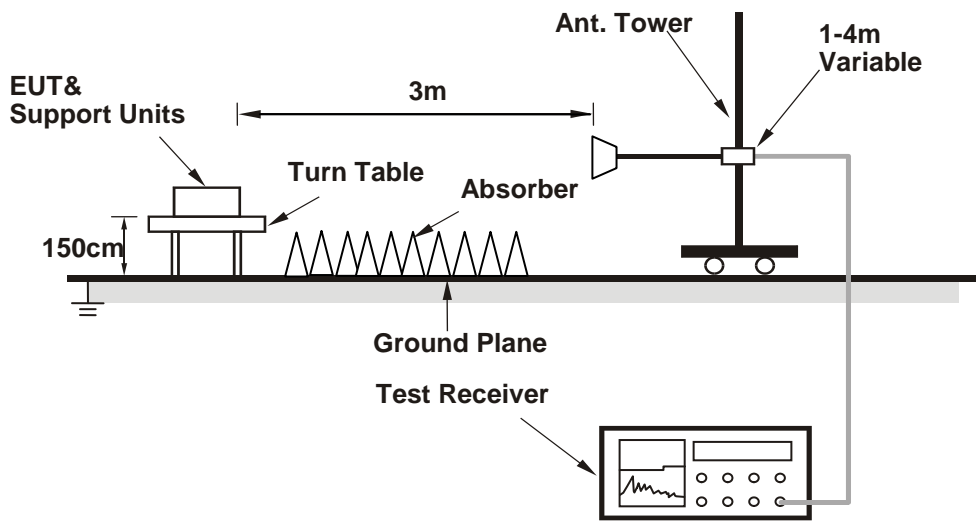

For the actual test configuration, please refer to the attached file (Test Setup Photo).

4.1.7 EUT Operating Conditions

- Placed the EUT on a testing table.
- Use the software to control the EUT under transmission condition continuously at specific channel frequency.

4.1.8 Test Results
ABOVE 1GHz DATA :
MODE A
802.11a

EUT TEST CONDITION		MEASUREMENT DETAIL	
CHANNEL	Channel 36	FREQUENCY RANGE	1GHz ~ 40GHz
INPUT POWER	120Vac, 60 Hz	DETECTOR FUNCTION	Peak (PK) Average (AV)
ENVIRONMENTAL CONDITIONS	25deg. C, 65%RH	TESTED BY	Gavin Wu

ANTENNA POLARITY & TEST DISTANCE: HORIZONTAL AT 3 M										
FREQ. (MHz)	EMISSION LEVEL (dBuV/m)	READ LEVEL (dBuV)	LIMIT (dBuV/m)	MARGIN (dB)	ANTENNA FACTOR (dB/m)	CABLE LOSS (dB)	PREAMP FACTOR (dB)	ANTENNA HEIGHT (cm)	TABLE ANGLE (Degree)	REMARK
5120	40.16	39.98	54	-13.84	31.29	6.19	37.3	201	245	Average
5120	60.01	59.83	74	-13.99	31.29	6.19	37.3	201	245	Peak
5180	95.25	95.02			31.35	6.22	37.34	201	245	Average
5180	104.43	104.2			31.35	6.22	37.34	201	245	Peak
5442	38.65	37.89	54	-15.35	31.55	6.34	37.13	201	245	Average
5442	60.33	59.57	74	-13.67	31.55	6.34	37.13	201	245	Peak
ANTENNA POLARITY & TEST DISTANCE: VERTICAL AT 3 M										
FREQ. (MHz)	EMISSION LEVEL (dBuV/m)	READ LEVEL (dBuV)	LIMIT (dBuV/m)	MARGIN (dB)	ANTENNA FACTOR (dB/m)	CABLE LOSS (dB)	PREAMP FACTOR (dB)	ANTENNA HEIGHT (cm)	TABLE ANGLE (Degree)	REMARK
5060	38.98	38.81	54	-15.02	31.25	6.17	37.25	199	281	Average
5060	60.15	59.98	74	-13.85	31.25	6.17	37.25	199	281	Peak
5180	91.8	91.57			31.35	6.22	37.34	199	281	Average
5180	101.26	101.03			31.35	6.22	37.34	199	281	Peak
5438	38.3	37.54	54	-15.7	31.55	6.34	37.13	199	281	Average
5438	59.66	58.9	74	-14.34	31.55	6.34	37.13	199	281	Peak

REMARKS:

- Emission Level = Read Level + Antenna Factor + Cable Loss - Preamp Factor
Margin value = Emission level – Limit value
- 5180MHz: Fundamental frequency.



A D T

EUT TEST CONDITION		MEASUREMENT DETAIL	
CHANNEL	Channel 44	FREQUENCY RANGE	1GHz ~ 40GHz
INPUT POWER	120Vac, 60 Hz	DETECTOR FUNCTION	Peak (PK) Average (AV)
ENVIRONMENTAL CONDITIONS	25deg. C, 65%RH	TESTED BY	Gavin Wu

ANTENNA POLARITY & TEST DISTANCE: HORIZONTAL AT 3 M										
FREQ. (MHz)	EMISSION LEVEL (dBuV/m)	READ LEVEL (dBuV)	LIMIT (dBuV/m)	MARGIN (dB)	ANTENNA FACTOR (dB/m)	CABLE LOSS (dB)	PREAMP FACTOR (dB)	ANTENNA HEIGHT (cm)	TABLE ANGLE (Degree)	REMARK
5126	39	38.79	54	-15	31.31	6.2	37.3	214	228	Average
5126	60.5	60.29	74	-13.5	31.31	6.2	37.3	214	228	Peak
5220	95.36	95.11			31.37	6.24	37.36	214	228	Average
5220	104.49	104.24			31.37	6.24	37.36	214	228	Peak
5456	38.52	37.7	54	-15.48	31.56	6.34	37.08	214	228	Average
5456	60.17	59.35	74	-13.83	31.56	6.34	37.08	214	228	Peak

ANTENNA POLARITY & TEST DISTANCE: VERTICAL AT 3 M										
FREQ. (MHz)	EMISSION LEVEL (dBuV/m)	READ LEVEL (dBuV)	LIMIT (dBuV/m)	MARGIN (dB)	ANTENNA FACTOR (dB/m)	CABLE LOSS (dB)	PREAMP FACTOR (dB)	ANTENNA HEIGHT (cm)	TABLE ANGLE (Degree)	REMARK
5008	38.5	38.39	54	-15.5	31.21	6.13	37.23	206	272	Average
5008	60.03	59.92	74	-13.97	31.21	6.13	37.23	206	272	Peak
5220	91.18	90.93			31.37	6.24	37.36	206	272	Average
5220	100.42	100.17			31.37	6.24	37.36	206	272	Peak
5354	38.33	37.74	54	-15.67	31.48	6.29	37.18	206	272	Average
5354	60.05	59.46	74	-13.95	31.48	6.29	37.18	206	272	Peak

REMARKS:

1. Emission Level = Read Level + Antenna Factor + Cable Loss - Preamp Factor
Margin value = Emission level – Limit value
2. 5220MHz: Fundamental frequency.



A D T

EUT TEST CONDITION		MEASUREMENT DETAIL	
CHANNEL	Channel 48	FREQUENCY RANGE	1GHz ~ 40GHz
INPUT POWER	120Vac, 60 Hz	DETECTOR FUNCTION	Peak (PK) Average (AV)
ENVIRONMENTAL CONDITIONS	25deg. C, 65%RH	TESTED BY	Gavin Wu

ANTENNA POLARITY & TEST DISTANCE: HORIZONTAL AT 3 M										
FREQ. (MHz)	EMISSION LEVEL (dBuV/m)	READ LEVEL (dBuV)	LIMIT (dBuV/m)	MARGIN (dB)	ANTENNA FACTOR (dB/m)	CABLE LOSS (dB)	PREAMP FACTOR (dB)	ANTENNA HEIGHT (cm)	TABLE ANGLE (Degree)	REMARK
5030	39.28	39.14	54	-14.72	31.23	6.15	37.24	218	241	Average
5030	60.85	60.71	74	-13.15	31.23	6.15	37.24	218	241	Peak
5240	95.35	95.03			31.39	6.25	37.32	218	241	Average
5240	104.42	104.1			31.39	6.25	37.32	218	241	Peak
5426	38.69	37.97	54	-15.31	31.53	6.32	37.13	218	241	Average
5426	60.14	59.42	74	-13.86	31.53	6.32	37.13	218	241	Peak

ANTENNA POLARITY & TEST DISTANCE: VERTICAL AT 3 M										
FREQ. (MHz)	EMISSION LEVEL (dBuV/m)	READ LEVEL (dBuV)	LIMIT (dBuV/m)	MARGIN (dB)	ANTENNA FACTOR (dB/m)	CABLE LOSS (dB)	PREAMP FACTOR (dB)	ANTENNA HEIGHT (cm)	TABLE ANGLE (Degree)	REMARK
5150	38.89	38.69	54	-15.11	31.32	6.2	37.32	214	293	Average
5150	59.49	59.29	74	-14.51	31.32	6.2	37.32	214	293	Peak
5240	91.27	90.95			31.39	6.25	37.32	214	293	Average
5240	100.47	100.15			31.39	6.25	37.32	214	293	Peak
5420	38.34	37.67	54	-15.66	31.53	6.32	37.18	214	293	Average
5420	59.59	58.92	74	-14.41	31.53	6.32	37.18	214	293	Peak

REMARKS:

- Emission Level = Read Level + Antenna Factor + Cable Loss - Preamp Factor
Margin value = Emission level – Limit value
- 5240MHz: Fundamental frequency.



A D T

EUT TEST CONDITION		MEASUREMENT DETAIL	
CHANNEL	Channel 52	FREQUENCY RANGE	1GHz ~ 40GHz
INPUT POWER	120Vac, 60 Hz	DETECTOR FUNCTION	Peak (PK) Average (AV)
ENVIRONMENTAL CONDITIONS	25deg. C, 65%RH	TESTED BY	Gavin Wu

ANTENNA POLARITY & TEST DISTANCE: HORIZONTAL AT 3 M										
FREQ. (MHz)	EMISSION LEVEL (dBuV/m)	READ LEVEL (dBuV)	LIMIT (dBuV/m)	MARGIN (dB)	ANTENNA FACTOR (dB/m)	CABLE LOSS (dB)	PREAMP FACTOR (dB)	ANTENNA HEIGHT (cm)	TABLE ANGLE (Degree)	REMARK
5040	38.24	38.09	54	-15.76	31.24	6.15	37.24	140	128	Average
5040	60.04	59.89	74	-13.96	31.24	6.15	37.24	140	128	Peak
5260	95.26	94.87			31.41	6.25	37.27	140	128	Average
5260	104.8	104.41			31.41	6.25	37.27	140	128	Peak
5420	38.68	38.01	54	-15.32	31.53	6.32	37.18	140	128	Average
5420	60.83	60.16	74	-13.17	31.53	6.32	37.18	140	128	Peak
ANTENNA POLARITY & TEST DISTANCE: VERTICAL AT 3 M										
FREQ. (MHz)	EMISSION LEVEL (dBuV/m)	READ LEVEL (dBuV)	LIMIT (dBuV/m)	MARGIN (dB)	ANTENNA FACTOR (dB/m)	CABLE LOSS (dB)	PREAMP FACTOR (dB)	ANTENNA HEIGHT (cm)	TABLE ANGLE (Degree)	REMARK
5104	38.24	38.05	54	-15.76	31.28	6.19	37.28	123	57	Average
5104	59.92	59.73	74	-14.08	31.28	6.19	37.28	123	57	Peak
5260	90.65	90.26			31.41	6.25	37.27	123	57	Average
5260	99.7	99.31			31.41	6.25	37.27	123	57	Peak
5378	38.23	37.59	54	-15.77	31.51	6.31	37.18	123	57	Average
5378	60.03	59.39	74	-13.97	31.51	6.31	37.18	123	57	Peak

REMARKS:

- Emission Level = Read Level + Antenna Factor + Cable Loss - Preamp Factor
Margin value = Emission level – Limit value
- 5260MHz: Fundamental frequency.



A D T

EUT TEST CONDITION		MEASUREMENT DETAIL		
CHANNEL	Channel 60	FREQUENCY RANGE	1GHz ~ 40GHz	
INPUT POWER	120Vac, 60 Hz	DETECTOR FUNCTION	Peak (PK) Average (AV)	
ENVIRONMENTAL CONDITIONS	25deg. C, 65%RH	TESTED BY	Gavin Wu	

ANTENNA POLARITY & TEST DISTANCE: HORIZONTAL AT 3 M										
FREQ. (MHz)	EMISSION LEVEL (dBuV/m)	READ LEVEL (dBuV)	LIMIT (dBuV/m)	MARGIN (dB)	ANTENNA FACTOR (dB/m)	CABLE LOSS (dB)	PREAMP FACTOR (dB)	ANTENNA HEIGHT (cm)	TABLE ANGLE (Degree)	REMARK
5030	38.3	38.16	54	-15.7	31.23	6.15	37.24	142	114	Average
5030	60.25	60.11	74	-13.75	31.23	6.15	37.24	142	114	Peak
5300	95.2	94.68			31.44	6.27	37.19	142	114	Average
5300	104.75	104.23			31.44	6.27	37.19	142	114	Peak
5458	40.43	39.61	54	-13.57	31.56	6.34	37.08	142	114	Average
5458	60.68	59.86	74	-13.32	31.56	6.34	37.08	142	114	Peak

ANTENNA POLARITY & TEST DISTANCE: VERTICAL AT 3 M										
FREQ. (MHz)	EMISSION LEVEL (dBuV/m)	READ LEVEL (dBuV)	LIMIT (dBuV/m)	MARGIN (dB)	ANTENNA FACTOR (dB/m)	CABLE LOSS (dB)	PREAMP FACTOR (dB)	ANTENNA HEIGHT (cm)	TABLE ANGLE (Degree)	REMARK
5038	38.28	38.13	54	-15.72	31.24	6.15	37.24	118	66	Average
5038	60.38	60.23	74	-13.62	31.24	6.15	37.24	118	66	Peak
5300	90.03	89.51			31.44	6.27	37.19	118	66	Average
5300	99.53	99.01			31.44	6.27	37.19	118	66	Peak
5354	38.25	37.66	54	-15.75	31.48	6.29	37.18	118	66	Average
5354	59.84	59.25	74	-14.16	31.48	6.29	37.18	118	66	Peak

REMARKS:

1. Emission Level = Read Level + Antenna Factor + Cable Loss - Preamp Factor
Margin value = Emission level – Limit value
2. 5300MHz: Fundamental frequency.



A D T

EUT TEST CONDITION		MEASUREMENT DETAIL	
CHANNEL	Channel 64	FREQUENCY RANGE	1GHz ~ 40GHz
INPUT POWER	120Vac, 60 Hz	DETECTOR FUNCTION	Peak (PK) Average (AV)
ENVIRONMENTAL CONDITIONS	25deg. C, 65%RH	TESTED BY	Gavin Wu

ANTENNA POLARITY & TEST DISTANCE: HORIZONTAL AT 3 M										
FREQ. (MHz)	EMISSION LEVEL (dBuV/m)	READ LEVEL (dBuV)	LIMIT (dBuV/m)	MARGIN (dB)	ANTENNA FACTOR (dB/m)	CABLE LOSS (dB)	PREAMP FACTOR (dB)	ANTENNA HEIGHT (cm)	TABLE ANGLE (Degree)	REMARK
5108	38.43	38.23	54	-15.57	31.29	6.19	37.28	138	122	Average
5108	60.83	60.63	74	-13.17	31.29	6.19	37.28	138	122	Peak
5320	95.33	94.78			31.45	6.29	37.19	138	122	Average
5320	104.81	104.26			31.45	6.29	37.19	138	122	Peak
5424	40.65	39.98	54	-13.35	31.53	6.32	37.18	138	122	Average
5424	60.47	59.8	74	-13.53	31.53	6.32	37.18	138	122	Peak

ANTENNA POLARITY & TEST DISTANCE: VERTICAL AT 3 M										
FREQ. (MHz)	EMISSION LEVEL (dBuV/m)	READ LEVEL (dBuV)	LIMIT (dBuV/m)	MARGIN (dB)	ANTENNA FACTOR (dB/m)	CABLE LOSS (dB)	PREAMP FACTOR (dB)	ANTENNA HEIGHT (cm)	TABLE ANGLE (Degree)	REMARK
5096	38.39	38.2	54	-15.61	31.28	6.19	37.28	120	61	Average
5096	60.4	60.21	74	-13.6	31.28	6.19	37.28	120	61	Peak
5320	90.37	89.82			31.45	6.29	37.19	120	61	Average
5320	99.52	98.97			31.45	6.29	37.19	120	61	Peak
5352	38.67	38.08	54	-15.33	31.48	6.29	37.18	120	61	Average
5352	59.98	59.39	74	-14.02	31.48	6.29	37.18	120	61	Peak

REMARKS:

- Emission Level = Read Level + Antenna Factor + Cable Loss - Preamp Factor
Margin value = Emission level – Limit value
- 5320MHz: Fundamental frequency.



EUT TEST CONDITION		MEASUREMENT DETAIL	
CHANNEL	Channel 100	FREQUENCY RANGE	1GHz ~ 40GHz
INPUT POWER	120Vac, 60 Hz	DETECTOR FUNCTION	Peak (PK) Average (AV)
ENVIRONMENTAL CONDITIONS	25deg. C, 65%RH	TESTED BY	Gavin Wu

ANTENNA POLARITY & TEST DISTANCE: HORIZONTAL AT 3 M

FREQ. (MHz)	EMISSION LEVEL (dBuV/m)	READ LEVEL (dBuV)	LIMIT (dBuV/m)	MARGIN (dB)	ANTENNA FACTOR (dB/m)	CABLE LOSS (dB)	PREAMP FACTOR (dB)	ANTENNA HEIGHT (cm)	TABLE ANGLE (Degree)	REMARK
5458	39.75	38.93	54	-14.25	31.56	6.34	37.08	201	247	Average
5458	61.2	60.38	74	-12.8	31.56	6.34	37.08	201	247	Peak
5470	58.58	57.75	68.2	-9.62	31.57	6.34	37.08	201	247	Peak
5500	88.21	87.28			31.6	6.36	37.03	201	247	Average
5500	98.51	97.58			31.6	6.36	37.03	201	247	Peak
5725	61.65	60.37	68.2	-6.55	31.96	6.75	37.43	201	247	Peak

ANTENNA POLARITY & TEST DISTANCE: VERTICAL AT 3 M

FREQ. (MHz)	EMISSION LEVEL (dBuV/m)	READ LEVEL (dBuV)	LIMIT (dBuV/m)	MARGIN (dB)	ANTENNA FACTOR (dB/m)	CABLE LOSS (dB)	PREAMP FACTOR (dB)	ANTENNA HEIGHT (cm)	TABLE ANGLE (Degree)	REMARK
5430	44.36	43.62	54	-9.64	31.55	6.32	37.13	102	222	Average
5430	60.62	59.88	74	-13.38	31.55	6.32	37.13	102	222	Peak
5470	59.18	58.35	68.2	-9.02	31.57	6.34	37.08	102	222	Peak
5500	94.3	93.37			31.6	6.36	37.03	102	222	Average
5500	104.2	103.27			31.6	6.36	37.03	102	222	Peak
5725	59.8	58.52	68.2	-8.4	31.96	6.75	37.43	102	222	Peak

REMARKS:

- Emission Level = Read Level + Antenna Factor + Cable Loss - Preamp Factor
Margin value = Emission level – Limit value
- 5500MHz: Fundamental frequency.
- 5470MHz & 5725MHz: Out of restricted band

EUT TEST CONDITION		MEASUREMENT DETAIL	
CHANNEL	Channel 116	FREQUENCY RANGE	1GHz ~ 40GHz
INPUT POWER	120Vac, 60 Hz	DETECTOR FUNCTION	Peak (PK) Average (AV)
ENVIRONMENTAL CONDITIONS	25deg. C, 65%RH	TESTED BY	Gavin Wu

ANTENNA POLARITY & TEST DISTANCE: HORIZONTAL AT 3 M										
FREQ. (MHz)	EMISSION LEVEL (dBuV/m)	READ LEVEL (dBuV)	LIMIT (dBuV/m)	MARGIN (dB)	ANTENNA FACTOR (dB/m)	CABLE LOSS (dB)	PREAMP FACTOR (dB)	ANTENNA HEIGHT (cm)	TABLE ANGLE (Degree)	REMARK
5430	39.25	38.51	54	-14.75	31.55	6.32	37.13	217	241	Average
5430	60.65	59.91	74	-13.35	31.55	6.32	37.13	217	241	Peak
5470	58.29	57.46	68.2	-9.91	31.57	6.34	37.08	217	241	Peak
5580	89.37	88.33			31.71	6.49	37.16	217	241	Average
5580	98.75	97.71			31.71	6.49	37.16	217	241	Peak
5725	59.59	58.31	68.2	-8.61	31.96	6.75	37.43	217	241	Peak
ANTENNA POLARITY & TEST DISTANCE: VERTICAL AT 3 M										
FREQ. (MHz)	EMISSION LEVEL (dBuV/m)	READ LEVEL (dBuV)	LIMIT (dBuV/m)	MARGIN (dB)	ANTENNA FACTOR (dB/m)	CABLE LOSS (dB)	PREAMP FACTOR (dB)	ANTENNA HEIGHT (cm)	TABLE ANGLE (Degree)	REMARK
5368	39.4	38.78	54	-14.6	31.49	6.31	37.18	100	219	Average
5368	61.5	60.88	74	-12.5	31.49	6.31	37.18	100	219	Peak
5470	59.55	58.72	68.2	-8.65	31.57	6.34	37.08	100	219	Peak
5580	95.69	94.65			31.71	6.49	37.16	100	219	Average
5580	105.08	104.04			31.71	6.49	37.16	100	219	Peak
5725	59.16	57.88	68.2	-9.04	31.96	6.75	37.43	100	219	Peak

REMARKS:

- Emission Level = Read Level + Antenna Factor + Cable Loss - Preamp Factor
Margin value = Emission level – Limit value
- 5580MHz: Fundamental frequency.
- 5470MHz & 5725MHz: Out of restricted band



A D T

EUT TEST CONDITION		MEASUREMENT DETAIL	
CHANNEL	Channel 140	FREQUENCY RANGE	1GHz ~ 40GHz
INPUT POWER	120Vac, 60 Hz	DETECTOR FUNCTION	Peak (PK) Average (AV)
ENVIRONMENTAL CONDITIONS	25deg. C, 65%RH	TESTED BY	Gavin Wu

ANTENNA POLARITY & TEST DISTANCE: HORIZONTAL AT 3 M										
FREQ. (MHz)	EMISSION LEVEL (dBuV/m)	READ LEVEL (dBuV)	LIMIT (dBuV/m)	MARGIN (dB)	ANTENNA FACTOR (dB/m)	CABLE LOSS (dB)	PREAMP FACTOR (dB)	ANTENNA HEIGHT (cm)	TABLE ANGLE (Degree)	REMARK
5416	38.93	38.26	54	-15.07	31.53	6.32	37.18	204	242	Average
5416	60.77	60.1	74	-13.23	31.53	6.32	37.18	204	242	Peak
5470	58.65	57.82	68.2	-9.55	31.57	6.34	37.08	204	242	Peak
5700	88.24	87.05			31.9	6.69	37.4	204	242	Average
5700	98.8	97.61			31.9	6.69	37.4	204	242	Peak
5725	60.8	59.52	68.2	-7.4	31.96	6.75	37.43	204	242	Peak
ANTENNA POLARITY & TEST DISTANCE: VERTICAL AT 3 M										
FREQ. (MHz)	EMISSION LEVEL (dBuV/m)	READ LEVEL (dBuV)	LIMIT (dBuV/m)	MARGIN (dB)	ANTENNA FACTOR (dB/m)	CABLE LOSS (dB)	PREAMP FACTOR (dB)	ANTENNA HEIGHT (cm)	TABLE ANGLE (Degree)	REMARK
5454	40.19	39.37	54	-13.81	31.56	6.34	37.08	131	217	Average
5454	61.21	60.39	74	-12.79	31.56	6.34	37.08	131	217	Peak
5470	59.73	58.9	68.2	-8.47	31.57	6.34	37.08	131	217	Peak
5700	95.56	94.37			31.9	6.69	37.4	131	217	Average
5700	104.97	103.78			31.9	6.69	37.4	131	217	Peak
5725	65.09	63.81	68.2	-3.11	31.96	6.75	37.43	131	217	Peak

REMARKS:

- Emission Level = Read Level + Antenna Factor + Cable Loss - Preamp Factor
Margin value = Emission level – Limit value
- 5700MHz: Fundamental frequency.
- 5470MHz & 5725MHz: Out of restricted band

EUT TEST CONDITION		MEASUREMENT DETAIL	
CHANNEL	Channel 149	FREQUENCY RANGE	1GHz ~ 40GHz
INPUT POWER	120Vac, 60 Hz	DETECTOR FUNCTION	Peak (PK) Average (AV)
ENVIRONMENTAL CONDITIONS	25deg. C, 65%RH	TESTED BY	Gavin Wu

ANTENNA POLARITY & TEST DISTANCE: HORIZONTAL AT 3 M										
FREQ. (MHz)	EMISSION LEVEL (dBuV/m)	READ LEVEL (dBuV)	LIMIT (dBuV/m)	MARGIN (dB)	ANTENNA FACTOR (dB/m)	CABLE LOSS (dB)	PREAMP FACTOR (dB)	ANTENNA HEIGHT (cm)	TABLE ANGLE (Degree)	REMARK
*5714	61.41	60.22	68.2	-6.79	31.93	6.69	37.43	174	207	Peak
*5725	65.54	64.26	78.2	-12.66	31.96	6.75	37.43	174	207	Peak
5745	95.87	94.6			31.99	6.75	37.47	174	207	Average
5745	105.24	103.97			31.99	6.75	37.47	174	207	Peak
*5850	61.61	60.09	78.2	-16.59	32.15	6.88	37.51	174	207	Peak
*5861	59.81	58.18	68.2	-8.39	32.18	6.95	37.5	174	207	Peak
ANTENNA POLARITY & TEST DISTANCE: VERTICAL AT 3 M										
FREQ. (MHz)	EMISSION LEVEL (dBuV/m)	READ LEVEL (dBuV)	LIMIT (dBuV/m)	MARGIN (dB)	ANTENNA FACTOR (dB/m)	CABLE LOSS (dB)	PREAMP FACTOR (dB)	ANTENNA HEIGHT (cm)	TABLE ANGLE (Degree)	REMARK
*5714	60.35	59.16	68.2	-7.85	31.93	6.69	37.43	196	344	Peak
*5725	60.11	58.83	78.2	-18.09	31.96	6.75	37.43	196	344	Peak
5745	91.09	89.82			31.99	6.75	37.47	196	344	Average
5745	101.58	100.31			31.99	6.75	37.47	196	344	Peak
*5850	59.98	58.46	78.2	-18.22	32.15	6.88	37.51	196	344	Peak
*5861	59.84	58.21	68.2	-8.36	32.18	6.95	37.5	196	344	Peak

REMARKS:

- Emission Level = Read Level + Antenna Factor + Cable Loss - Preamp Factor
Margin value = Emission level – Limit value
- 5745MHz: Fundamental frequency.
- *: Out of restricted band



A D T

EUT TEST CONDITION		MEASUREMENT DETAIL	
CHANNEL	Channel 157	FREQUENCY RANGE	1GHz ~ 40GHz
INPUT POWER	120Vac, 60 Hz	DETECTOR FUNCTION	Peak (PK) Average (AV)
ENVIRONMENTAL CONDITIONS	25deg. C, 65%RH	TESTED BY	Gavin Wu

ANTENNA POLARITY & TEST DISTANCE: HORIZONTAL AT 3 M										
FREQ. (MHz)	EMISSION LEVEL (dBuV/m)	READ LEVEL (dBuV)	LIMIT (dBuV/m)	MARGIN (dB)	ANTENNA FACTOR (dB/m)	CABLE LOSS (dB)	PREAMP FACTOR (dB)	ANTENNA HEIGHT (cm)	TABLE ANGLE (Degree)	REMARK
*5714	59.67	58.48	68.2	-8.53	31.93	6.69	37.43	201	242	Peak
*5725	59.76	58.48	78.2	-18.44	31.96	6.75	37.43	201	242	Peak
5785	94.25	92.93			32.04	6.82	37.54	201	242	Average
5785	104.93	103.61			32.04	6.82	37.54	201	242	Peak
*5850	60.56	59.04	78.2	-17.64	32.15	6.88	37.51	201	242	Peak
*5861	61.25	59.62	68.2	-6.95	32.18	6.95	37.5	201	242	Peak

ANTENNA POLARITY & TEST DISTANCE: VERTICAL AT 3 M										
FREQ. (MHz)	EMISSION LEVEL (dBuV/m)	READ LEVEL (dBuV)	LIMIT (dBuV/m)	MARGIN (dB)	ANTENNA FACTOR (dB/m)	CABLE LOSS (dB)	PREAMP FACTOR (dB)	ANTENNA HEIGHT (cm)	TABLE ANGLE (Degree)	REMARK
*5714	60.09	58.9	68.2	-8.11	31.93	6.69	37.43	194	344	Peak
*5725	59.99	58.71	78.2	-18.21	31.96	6.75	37.43	194	344	Peak
5785	90.68	89.36			32.04	6.82	37.54	194	344	Average
5785	100.13	98.81			32.04	6.82	37.54	194	344	Peak
*5850	61.4	59.88	78.2	-16.8	32.15	6.88	37.51	194	344	Peak
*5861	59.83	58.2	68.2	-8.37	32.18	6.95	37.5	194	344	Peak

REMARKS:

- Emission Level = Read Level + Antenna Factor + Cable Loss - Preamp Factor
Margin value = Emission level – Limit value
- 5785MHz: Fundamental frequency.
- *: Out of restricted band



A D T

EUT TEST CONDITION		MEASUREMENT DETAIL	
CHANNEL	Channel 165	FREQUENCY RANGE	1GHz ~ 40GHz
INPUT POWER	120Vac, 60 Hz	DETECTOR FUNCTION	Peak (PK) Average (AV)
ENVIRONMENTAL CONDITIONS	25deg. C, 65%RH	TESTED BY	Gavin Wu

ANTENNA POLARITY & TEST DISTANCE: HORIZONTAL AT 3 M										
FREQ. (MHz)	EMISSION LEVEL (dBuV/m)	READ LEVEL (dBuV)	LIMIT (dBuV/m)	MARGIN (dB)	ANTENNA FACTOR (dB/m)	CABLE LOSS (dB)	PREAMP FACTOR (dB)	ANTENNA HEIGHT (cm)	TABLE ANGLE (Degree)	REMARK
*5714	59.54	58.35	68.2	-8.66	31.93	6.69	37.43	200	246	Peak
*5725	59.62	58.34	78.2	-18.58	31.96	6.75	37.43	200	246	Peak
5825	94.85	93.38			32.12	6.88	37.53	200	246	Average
5825	104.16	102.69			32.12	6.88	37.53	200	246	Peak
*5850	62.6	61.08	78.2	-15.6	32.15	6.88	37.51	200	246	Peak
*5861	59.28	57.65	68.2	-8.92	32.18	6.95	37.5	200	246	Peak
ANTENNA POLARITY & TEST DISTANCE: VERTICAL AT 3 M										
FREQ. (MHz)	EMISSION LEVEL (dBuV/m)	READ LEVEL (dBuV)	LIMIT (dBuV/m)	MARGIN (dB)	ANTENNA FACTOR (dB/m)	CABLE LOSS (dB)	PREAMP FACTOR (dB)	ANTENNA HEIGHT (cm)	TABLE ANGLE (Degree)	REMARK
*5714	59.97	58.78	68.2	-8.23	31.93	6.69	37.43	194	344	Peak
*5725	60.97	59.69	78.2	-17.23	31.96	6.75	37.43	194	344	Peak
5825	90.73	89.26			32.12	6.88	37.53	194	344	Average
5825	100.34	98.87			32.12	6.88	37.53	194	344	Peak
*5850	59.48	57.96	78.2	-18.72	32.15	6.88	37.51	194	344	Peak
*5861	58.88	57.25	68.2	-9.32	32.18	6.95	37.5	194	344	Peak

REMARKS:

- Emission Level = Read Level + Antenna Factor + Cable Loss - Preamp Factor
Margin value = Emission level – Limit value
- 5825MHz: Fundamental frequency.
- *: Out of restricted band

802.11n (20MHz)

EUT TEST CONDITION		MEASUREMENT DETAIL	
CHANNEL	Channel 36	FREQUENCY RANGE	1GHz ~ 40GHz
INPUT POWER	120Vac, 60 Hz	DETECTOR FUNCTION	Peak (PK) Average (AV)
ENVIRONMENTAL CONDITIONS	25deg. C, 65%RH	TESTED BY	Gavin Wu

ANTENNA POLARITY & TEST DISTANCE: HORIZONTAL AT 3 M

FREQ. (MHz)	EMISSION LEVEL (dBuV/m)	READ LEVEL (dBuV)	LIMIT (dBuV/m)	MARGIN (dB)	ANTENNA FACTOR (dB/m)	CABLE LOSS (dB)	PREAMP FACTOR (dB)	ANTENNA HEIGHT (cm)	TABLE ANGLE (Degree)	REMARK
5146	41.02	40.82	54	-12.98	31.32	6.2	37.32	203	249	Average
5146	59.94	59.74	74	-14.06	31.32	6.2	37.32	203	249	Peak
5180	95.02	94.79			31.35	6.22	37.34	203	249	Average
5180	104.34	104.11			31.35	6.22	37.34	203	249	Peak
5428	38.48	37.76	54	-15.52	31.53	6.32	37.13	203	249	Average
5428	59.79	59.07	74	-14.21	31.53	6.32	37.13	203	249	Peak

ANTENNA POLARITY & TEST DISTANCE: VERTICAL AT 3 M

FREQ. (MHz)	EMISSION LEVEL (dBuV/m)	READ LEVEL (dBuV)	LIMIT (dBuV/m)	MARGIN (dB)	ANTENNA FACTOR (dB/m)	CABLE LOSS (dB)	PREAMP FACTOR (dB)	ANTENNA HEIGHT (cm)	TABLE ANGLE (Degree)	REMARK
5144	39.42	39.22	54	-14.58	31.32	6.2	37.32	199	259	Average
5144	59.95	59.75	74	-14.05	31.32	6.2	37.32	199	259	Peak
5180	91.23	91			31.35	6.22	37.34	199	259	Average
5180	100.43	100.2			31.35	6.22	37.34	199	259	Peak
5436	38.42	37.68	54	-15.58	31.55	6.32	37.13	199	259	Average
5436	60.79	60.05	74	-13.21	31.55	6.32	37.13	199	259	Peak

REMARKS:

- Emission Level = Read Level + Antenna Factor + Cable Loss - Preamp Factor
Margin value = Emission level – Limit value
- 5180MHz: Fundamental frequency.



A D T

EUT TEST CONDITION		MEASUREMENT DETAIL	
CHANNEL	Channel 44	FREQUENCY RANGE	1GHz ~ 40GHz
INPUT POWER	120Vac, 60 Hz	DETECTOR FUNCTION	Peak (PK) Average (AV)
ENVIRONMENTAL CONDITIONS	25deg. C, 65%RH	TESTED BY	Gavin Wu

ANTENNA POLARITY & TEST DISTANCE: HORIZONTAL AT 3 M										
FREQ. (MHz)	EMISSION LEVEL (dBuV/m)	READ LEVEL (dBuV)	LIMIT (dBuV/m)	MARGIN (dB)	ANTENNA FACTOR (dB/m)	CABLE LOSS (dB)	PREAMP FACTOR (dB)	ANTENNA HEIGHT (cm)	TABLE ANGLE (Degree)	REMARK
5146	38.9	38.7	54	-15.1	31.32	6.2	37.32	209	243	Average
5146	60.03	59.83	74	-13.97	31.32	6.2	37.32	209	243	Peak
5220	95.14	94.89			31.37	6.24	37.36	209	243	Average
5220	104.41	104.16			31.37	6.24	37.36	209	243	Peak
5350	38.44	37.85	54	-15.56	31.48	6.29	37.18	209	243	Average
5350	60.58	59.99	74	-13.42	31.48	6.29	37.18	209	243	Peak

ANTENNA POLARITY & TEST DISTANCE: VERTICAL AT 3 M										
FREQ. (MHz)	EMISSION LEVEL (dBuV/m)	READ LEVEL (dBuV)	LIMIT (dBuV/m)	MARGIN (dB)	ANTENNA FACTOR (dB/m)	CABLE LOSS (dB)	PREAMP FACTOR (dB)	ANTENNA HEIGHT (cm)	TABLE ANGLE (Degree)	REMARK
5110	38.63	38.43	54	-15.37	31.29	6.19	37.28	207	286	Average
5110	60.02	59.82	74	-13.98	31.29	6.19	37.28	207	286	Peak
5220	91.07	90.82			31.37	6.24	37.36	207	286	Average
5220	100.36	100.11			31.37	6.24	37.36	207	286	Peak
5396	38.25	37.6	54	-15.75	31.52	6.31	37.18	207	286	Average
5396	60.56	59.91	74	-13.44	31.52	6.31	37.18	207	286	Peak

REMARKS:

- Emission Level = Read Level + Antenna Factor + Cable Loss - Preamp Factor
Margin value = Emission level – Limit value
- 5220MHz: Fundamental frequency.



EUT TEST CONDITION		MEASUREMENT DETAIL	
CHANNEL	Channel 48	FREQUENCY RANGE	1GHz ~ 40GHz
INPUT POWER	120Vac, 60 Hz	DETECTOR FUNCTION	Peak (PK) Average (AV)
ENVIRONMENTAL CONDITIONS	25deg. C, 65%RH	TESTED BY	Gavin Wu

ANTENNA POLARITY & TEST DISTANCE: HORIZONTAL AT 3 M										
FREQ. (MHz)	EMISSION LEVEL (dBuV/m)	READ LEVEL (dBuV)	LIMIT (dBuV/m)	MARGIN (dB)	ANTENNA FACTOR (dB/m)	CABLE LOSS (dB)	PREAMP FACTOR (dB)	ANTENNA HEIGHT (cm)	TABLE ANGLE (Degree)	REMARK
5072	39	38.83	54	-15	31.27	6.17	37.27	215	234	Average
5072	60.11	59.94	74	-13.89	31.27	6.17	37.27	215	234	Peak
5240	95.19	94.87			31.39	6.25	37.32	215	234	Average
5240	104.45	104.13			31.39	6.25	37.32	215	234	Peak
5394	38.74	38.1	54	-15.26	31.51	6.31	37.18	215	234	Average
5394	60.9	60.26	74	-13.1	31.51	6.31	37.18	215	234	Peak
ANTENNA POLARITY & TEST DISTANCE: VERTICAL AT 3 M										
FREQ. (MHz)	EMISSION LEVEL (dBuV/m)	READ LEVEL (dBuV)	LIMIT (dBuV/m)	MARGIN (dB)	ANTENNA FACTOR (dB/m)	CABLE LOSS (dB)	PREAMP FACTOR (dB)	ANTENNA HEIGHT (cm)	TABLE ANGLE (Degree)	REMARK
5036	38.76	38.62	54	-15.24	31.23	6.15	37.24	206	278	Average
5036	60.48	60.34	74	-13.52	31.23	6.15	37.24	206	278	Peak
5240	91.22	90.9			31.39	6.25	37.32	206	278	Average
5240	100.36	100.04			31.39	6.25	37.32	206	278	Peak
5442	38.4	37.64	54	-15.6	31.55	6.34	37.13	206	278	Average
5442	60.1	59.34	74	-13.9	31.55	6.34	37.13	206	278	Peak

REMARKS:

- Emission Level = Read Level + Antenna Factor + Cable Loss - Preamp Factor
Margin value = Emission level – Limit value
- 5240MHz: Fundamental frequency.



EUT TEST CONDITION		MEASUREMENT DETAIL	
CHANNEL	Channel 52	FREQUENCY RANGE	1GHz ~ 40GHz
INPUT POWER	120Vac, 60 Hz	DETECTOR FUNCTION	Peak (PK) Average (AV)
ENVIRONMENTAL CONDITIONS	25deg. C, 65%RH	TESTED BY	Gavin Wu

ANTENNA POLARITY & TEST DISTANCE: HORIZONTAL AT 3 M										
FREQ. (MHz)	EMISSION LEVEL (dBuV/m)	READ LEVEL (dBuV)	LIMIT (dBuV/m)	MARGIN (dB)	ANTENNA FACTOR (dB/m)	CABLE LOSS (dB)	PREAMP FACTOR (dB)	ANTENNA HEIGHT (cm)	TABLE ANGLE (Degree)	REMARK
5032	38.28	38.14	54	-15.72	31.23	6.15	37.24	133	118	Average
5032	60.9	60.76	74	-13.1	31.23	6.15	37.24	133	118	Peak
5260	95.32	94.93			31.41	6.25	37.27	133	118	Average
5260	104.78	104.39			31.41	6.25	37.27	133	118	Peak
5380	38.71	38.07	54	-15.29	31.51	6.31	37.18	133	118	Average
5380	60.51	59.87	74	-13.49	31.51	6.31	37.18	133	118	Peak

ANTENNA POLARITY & TEST DISTANCE: VERTICAL AT 3 M										
FREQ. (MHz)	EMISSION LEVEL (dBuV/m)	READ LEVEL (dBuV)	LIMIT (dBuV/m)	MARGIN (dB)	ANTENNA FACTOR (dB/m)	CABLE LOSS (dB)	PREAMP FACTOR (dB)	ANTENNA HEIGHT (cm)	TABLE ANGLE (Degree)	REMARK
5070	38.93	38.78	54	-15.07	31.25	6.17	37.27	123	73	Average
5070	59.87	59.72	74	-14.13	31.25	6.17	37.27	123	73	Peak
5260	90.17	89.78			31.41	6.25	37.27	123	73	Average
5260	99.53	99.14			31.41	6.25	37.27	123	73	Peak
5378	38.26	37.62	54	-15.74	31.51	6.31	37.18	123	73	Average
5378	60.84	60.2	74	-13.16	31.51	6.31	37.18	123	73	Peak

REMARKS:

- Emission Level = Read Level + Antenna Factor + Cable Loss - Preamp Factor
Margin value = Emission level – Limit value
- 5260MHz: Fundamental frequency.



A D T

EUT TEST CONDITION		MEASUREMENT DETAIL	
CHANNEL	Channel 60	FREQUENCY RANGE	1GHz ~ 40GHz
INPUT POWER	120Vac, 60 Hz	DETECTOR FUNCTION	Peak (PK) Average (AV)
ENVIRONMENTAL CONDITIONS	25deg. C, 65%RH	TESTED BY	Gavin Wu

ANTENNA POLARITY & TEST DISTANCE: HORIZONTAL AT 3 M										
FREQ. (MHz)	EMISSION LEVEL (dBuV/m)	READ LEVEL (dBuV)	LIMIT (dBuV/m)	MARGIN (dB)	ANTENNA FACTOR (dB/m)	CABLE LOSS (dB)	PREAMP FACTOR (dB)	ANTENNA HEIGHT (cm)	TABLE ANGLE (Degree)	REMARK
5032	38.3	38.16	54	-15.7	31.23	6.15	37.24	147	108	Average
5032	59.91	59.77	74	-14.09	31.23	6.15	37.24	147	108	Peak
5300	95.21	94.69			31.44	6.27	37.19	147	108	Average
5300	104.73	104.21			31.44	6.27	37.19	147	108	Peak
5430	40.9	40.16	54	-13.1	31.55	6.32	37.13	147	108	Average
5430	60.2	59.46	74	-13.8	31.55	6.32	37.13	147	108	Peak

ANTENNA POLARITY & TEST DISTANCE: VERTICAL AT 3 M										
FREQ. (MHz)	EMISSION LEVEL (dBuV/m)	READ LEVEL (dBuV)	LIMIT (dBuV/m)	MARGIN (dB)	ANTENNA FACTOR (dB/m)	CABLE LOSS (dB)	PREAMP FACTOR (dB)	ANTENNA HEIGHT (cm)	TABLE ANGLE (Degree)	REMARK
5042	38.43	38.29	54	-15.57	31.24	6.15	37.25	121	48	Average
5042	60.2	60.06	74	-13.8	31.24	6.15	37.25	121	48	Peak
5300	90.32	89.8			31.44	6.27	37.19	121	48	Average
5300	99.67	99.15			31.44	6.27	37.19	121	48	Peak
5460	38.45	37.63	54	-15.55	31.56	6.34	37.08	121	48	Average
5460	60.15	59.33	74	-13.85	31.56	6.34	37.08	121	48	Peak

REMARKS:

- Emission Level = Read Level + Antenna Factor + Cable Loss - Preamp Factor
Margin value = Emission level – Limit value
- 5300MHz: Fundamental frequency.



A D T

EUT TEST CONDITION		MEASUREMENT DETAIL	
CHANNEL	Channel 64	FREQUENCY RANGE	1GHz ~ 40GHz
INPUT POWER	120Vac, 60 Hz	DETECTOR FUNCTION	Peak (PK) Average (AV)
ENVIRONMENTAL CONDITIONS	25deg. C, 65%RH	TESTED BY	Gavin Wu

ANTENNA POLARITY & TEST DISTANCE: HORIZONTAL AT 3 M										
FREQ. (MHz)	EMISSION LEVEL (dBuV/m)	READ LEVEL (dBuV)	LIMIT (dBuV/m)	MARGIN (dB)	ANTENNA FACTOR (dB/m)	CABLE LOSS (dB)	PREAMP FACTOR (dB)	ANTENNA HEIGHT (cm)	TABLE ANGLE (Degree)	REMARK
5008	38.33	38.22	54	-15.67	31.21	6.13	37.23	138	120	Average
5008	60.13	60.02	74	-13.87	31.21	6.13	37.23	138	120	Peak
5320	95.13	94.58			31.45	6.29	37.19	138	120	Average
5320	104.67	104.12			31.45	6.29	37.19	138	120	Peak
5404	40.99	40.33	54	-13.01	31.52	6.32	37.18	138	120	Average
5404	61.03	60.37	74	-12.97	31.52	6.32	37.18	138	120	Peak

ANTENNA POLARITY & TEST DISTANCE: VERTICAL AT 3 M										
FREQ. (MHz)	EMISSION LEVEL (dBuV/m)	READ LEVEL (dBuV)	LIMIT (dBuV/m)	MARGIN (dB)	ANTENNA FACTOR (dB/m)	CABLE LOSS (dB)	PREAMP FACTOR (dB)	ANTENNA HEIGHT (cm)	TABLE ANGLE (Degree)	REMARK
5086	38.37	38.2	54	-15.63	31.27	6.17	37.27	118	78	Average
5086	59.98	59.81	74	-14.02	31.27	6.17	37.27	118	78	Peak
5320	90.12	89.57			31.45	6.29	37.19	118	78	Average
5320	99.41	98.86			31.45	6.29	37.19	118	78	Peak
5384	38.47	37.83	54	-15.53	31.51	6.31	37.18	118	78	Average
5384	60.81	60.17	74	-13.19	31.51	6.31	37.18	118	78	Peak

REMARKS:

1. Emission Level = Read Level + Antenna Factor + Cable Loss - Preamp Factor
Margin value = Emission level – Limit value
2. 5320MHz: Fundamental frequency.



EUT TEST CONDITION		MEASUREMENT DETAIL	
CHANNEL	Channel 100	FREQUENCY RANGE	1GHz ~ 40GHz
INPUT POWER	120Vac, 60 Hz	DETECTOR FUNCTION	Peak (PK) Average (AV)
ENVIRONMENTAL CONDITIONS	25deg. C, 65%RH	TESTED BY	Gavin Wu

ANTENNA POLARITY & TEST DISTANCE: HORIZONTAL AT 3 M

FREQ. (MHz)	EMISSION LEVEL (dBuV/m)	READ LEVEL (dBuV)	LIMIT (dBuV/m)	MARGIN (dB)	ANTENNA FACTOR (dB/m)	CABLE LOSS (dB)	PREAMP FACTOR (dB)	ANTENNA HEIGHT (cm)	TABLE ANGLE (Degree)	REMARK
5378	40.15	39.51	54	-13.85	31.51	6.31	37.18	204	242	Average
5378	60.68	60.04	74	-13.32	31.51	6.31	37.18	204	242	Peak
5470	59.62	58.79	68.2	-8.58	31.57	6.34	37.08	204	242	Peak
5500	88.52	87.59			31.6	6.36	37.03	204	242	Average
5500	98.93	98			31.6	6.36	37.03	204	242	Peak
5725	60.03	58.75	68.2	-8.17	31.96	6.75	37.43	204	242	Peak

ANTENNA POLARITY & TEST DISTANCE: VERTICAL AT 3 M

FREQ. (MHz)	EMISSION LEVEL (dBuV/m)	READ LEVEL (dBuV)	LIMIT (dBuV/m)	MARGIN (dB)	ANTENNA FACTOR (dB/m)	CABLE LOSS (dB)	PREAMP FACTOR (dB)	ANTENNA HEIGHT (cm)	TABLE ANGLE (Degree)	REMARK
5364	42.43	41.81	54	-11.57	31.49	6.31	37.18	199	220	Average
5364	61.15	60.53	74	-12.85	31.49	6.31	37.18	199	220	Peak
5470	59.09	58.26	68.2	-9.11	31.57	6.34	37.08	199	220	Peak
5500	94.95	94.02			31.6	6.36	37.03	199	220	Average
5500	104.67	103.74			31.6	6.36	37.03	199	220	Peak
5725	59.69	58.41	68.2	-8.51	31.96	6.75	37.43	199	220	Peak

REMARKS:

- Emission Level = Read Level + Antenna Factor + Cable Loss - Preamp Factor
Margin value = Emission level – Limit value
- 5500MHz: Fundamental frequency.
- 5470MHz & 5725MHz: Out of restricted band



EUT TEST CONDITION		MEASUREMENT DETAIL	
CHANNEL	Channel 116	FREQUENCY RANGE	1GHz ~ 40GHz
INPUT POWER	120Vac, 60 Hz	DETECTOR FUNCTION	Peak (PK) Average (AV)
ENVIRONMENTAL CONDITIONS	25deg. C, 65%RH	TESTED BY	Gavin Wu

ANTENNA POLARITY & TEST DISTANCE: HORIZONTAL AT 3 M										
FREQ. (MHz)	EMISSION LEVEL (dBuV/m)	READ LEVEL (dBuV)	LIMIT (dBuV/m)	MARGIN (dB)	ANTENNA FACTOR (dB/m)	CABLE LOSS (dB)	PREAMP FACTOR (dB)	ANTENNA HEIGHT (cm)	TABLE ANGLE (Degree)	REMARK
5444	39.17	38.41	54	-14.83	31.55	6.34	37.13	200	241	Average
5444	60.12	59.36	74	-13.88	31.55	6.34	37.13	200	241	Peak
5470	58.29	57.46	68.2	-9.91	31.57	6.34	37.08	200	241	Peak
5580	88.29	87.25			31.71	6.49	37.16	200	241	Average
5580	98.7	97.66			31.71	6.49	37.16	200	241	Peak
5725	60.38	59.1	68.2	-7.82	31.96	6.75	37.43	200	241	Peak
ANTENNA POLARITY & TEST DISTANCE: VERTICAL AT 3 M										
FREQ. (MHz)	EMISSION LEVEL (dBuV/m)	READ LEVEL (dBuV)	LIMIT (dBuV/m)	MARGIN (dB)	ANTENNA FACTOR (dB/m)	CABLE LOSS (dB)	PREAMP FACTOR (dB)	ANTENNA HEIGHT (cm)	TABLE ANGLE (Degree)	REMARK
5374	39.34	38.72	54	-14.66	31.49	6.31	37.18	107	223	Average
5374	59.92	59.3	74	-14.08	31.49	6.31	37.18	107	223	Peak
5470	59.23	58.4	68.2	-8.97	31.57	6.34	37.08	107	223	Peak
5580	95.69	94.65			31.71	6.49	37.16	107	223	Average
5580	105.17	104.13			31.71	6.49	37.16	107	223	Peak
5725	61.25	59.97	68.2	-6.95	31.96	6.75	37.43	107	223	Peak

REMARKS:

- Emission Level = Read Level + Antenna Factor + Cable Loss - Preamp Factor
Margin value = Emission level – Limit value
- 5580MHz: Fundamental frequency.
- 5470MHz & 5725MHz: Out of restricted band



A D T

EUT TEST CONDITION		MEASUREMENT DETAIL	
CHANNEL	Channel 140	FREQUENCY RANGE	1GHz ~ 40GHz
INPUT POWER	120Vac, 60 Hz	DETECTOR FUNCTION	Peak (PK) Average (AV)
ENVIRONMENTAL CONDITIONS	25deg. C, 65%RH	TESTED BY	Gavin Wu

ANTENNA POLARITY & TEST DISTANCE: HORIZONTAL AT 3 M										
FREQ. (MHz)	EMISSION LEVEL (dBuV/m)	READ LEVEL (dBuV)	LIMIT (dBuV/m)	MARGIN (dB)	ANTENNA FACTOR (dB/m)	CABLE LOSS (dB)	PREAMP FACTOR (dB)	ANTENNA HEIGHT (cm)	TABLE ANGLE (Degree)	REMARK
5354	38.84	38.25	54	-15.16	31.48	6.29	37.18	226	235	Average
5354	59.98	59.39	74	-14.02	31.48	6.29	37.18	226	235	Peak
5470	58.22	57.39	68.2	-9.98	31.57	6.34	37.08	226	235	Peak
5700	88.34	87.15			31.9	6.69	37.4	226	235	Average
5700	98.7	97.51			31.9	6.69	37.4	226	235	Peak
5725	59.07	57.79	68.2	-9.13	31.96	6.75	37.43	226	235	Peak

ANTENNA POLARITY & TEST DISTANCE: VERTICAL AT 3 M										
FREQ. (MHz)	EMISSION LEVEL (dBuV/m)	READ LEVEL (dBuV)	LIMIT (dBuV/m)	MARGIN (dB)	ANTENNA FACTOR (dB/m)	CABLE LOSS (dB)	PREAMP FACTOR (dB)	ANTENNA HEIGHT (cm)	TABLE ANGLE (Degree)	REMARK
5458	40.15	39.33	54	-13.85	31.56	6.34	37.08	118	222	Average
5458	61.06	60.24	74	-12.94	31.56	6.34	37.08	118	222	Peak
5470	59.15	58.32	68.2	-9.05	31.57	6.34	37.08	118	222	Peak
5700	94.98	93.79			31.9	6.69	37.4	118	222	Average
5700	104.66	103.47			31.9	6.69	37.4	118	222	Peak
5725	63.59	62.37	68.2	-4.61	31.96	6.69	37.43	118	222	Peak

REMARKS:

- Emission Level = Read Level + Antenna Factor + Cable Loss - Preamp Factor
Margin value = Emission level – Limit value
- 5700MHz: Fundamental frequency.
- 5470MHz & 5725MHz: Out of restricted band

EUT TEST CONDITION		MEASUREMENT DETAIL	
CHANNEL	Channel 149	FREQUENCY RANGE	1GHz ~ 40GHz
INPUT POWER	120Vac, 60 Hz	DETECTOR FUNCTION	Peak (PK) Average (AV)
ENVIRONMENTAL CONDITIONS	25deg. C, 65%RH	TESTED BY	Gavin Wu

ANTENNA POLARITY & TEST DISTANCE: HORIZONTAL AT 3 M										
FREQ. (MHz)	EMISSION LEVEL (dBuV/m)	READ LEVEL (dBuV)	LIMIT (dBuV/m)	MARGIN (dB)	ANTENNA FACTOR (dB/m)	CABLE LOSS (dB)	PREAMP FACTOR (dB)	ANTENNA HEIGHT (cm)	TABLE ANGLE (Degree)	REMARK
*5714	60.21	59.02	68.2	-7.99	31.93	6.69	37.43	180	210	Peak
*5725	66.7	65.42	78.2	-11.5	31.96	6.75	37.43	180	210	Peak
5745	94.85	93.58			31.99	6.75	37.47	180	210	Average
5745	104.42	103.15			31.99	6.75	37.47	180	210	Peak
*5850	60.25	58.73	78.2	-17.95	32.15	6.88	37.51	180	210	Peak
*5861	60.37	58.74	68.2	-7.83	32.18	6.95	37.5	180	210	Peak
ANTENNA POLARITY & TEST DISTANCE: VERTICAL AT 3 M										
FREQ. (MHz)	EMISSION LEVEL (dBuV/m)	READ LEVEL (dBuV)	LIMIT (dBuV/m)	MARGIN (dB)	ANTENNA FACTOR (dB/m)	CABLE LOSS (dB)	PREAMP FACTOR (dB)	ANTENNA HEIGHT (cm)	TABLE ANGLE (Degree)	REMARK
*5714	58.54	57.35	68.2	-9.66	31.93	6.69	37.43	212	343	Peak
*5725	59.72	58.44	78.2	-18.48	31.96	6.75	37.43	212	343	Peak
5745	90.25	88.98			31.99	6.75	37.47	212	343	Average
5745	100.92	99.65			31.99	6.75	37.47	212	343	Peak
*5850	59.09	57.57	78.2	-19.11	32.15	6.88	37.51	212	343	Peak
*5861	58.81	57.18	68.2	-9.39	32.18	6.95	37.5	212	343	Peak

REMARKS:

- Emission Level = Read Level + Antenna Factor + Cable Loss - Preamp Factor
Margin value = Emission level – Limit value
- 5745MHz: Fundamental frequency.
- *: Out of restricted band



A D T

EUT TEST CONDITION		MEASUREMENT DETAIL	
CHANNEL	Channel 157	FREQUENCY RANGE	1GHz ~ 40GHz
INPUT POWER	120Vac, 60 Hz	DETECTOR FUNCTION	Peak (PK) Average (AV)
ENVIRONMENTAL CONDITIONS	25deg. C, 65%RH	TESTED BY	Gavin Wu

ANTENNA POLARITY & TEST DISTANCE: HORIZONTAL AT 3 M										
FREQ. (MHz)	EMISSION LEVEL (dBuV/m)	READ LEVEL (dBuV)	LIMIT (dBuV/m)	MARGIN (dB)	ANTENNA FACTOR (dB/m)	CABLE LOSS (dB)	PREAMP FACTOR (dB)	ANTENNA HEIGHT (cm)	TABLE ANGLE (Degree)	REMARK
*5714	60.76	59.57	68.2	-7.44	31.93	6.69	37.43	191	210	Peak
*5725	59.66	58.38	78.2	-18.54	31.96	6.75	37.43	191	210	Peak
5785	94.85	93.53			32.04	6.82	37.54	191	210	Average
5785	104.22	102.9			32.04	6.82	37.54	191	210	Peak
*5850	60.21	58.69	78.2	-17.99	32.15	6.88	37.51	191	210	Peak
*5861	59.84	58.21	68.2	-8.36	32.18	6.95	37.5	191	210	Peak

ANTENNA POLARITY & TEST DISTANCE: VERTICAL AT 3 M										
FREQ. (MHz)	EMISSION LEVEL (dBuV/m)	READ LEVEL (dBuV)	LIMIT (dBuV/m)	MARGIN (dB)	ANTENNA FACTOR (dB/m)	CABLE LOSS (dB)	PREAMP FACTOR (dB)	ANTENNA HEIGHT (cm)	TABLE ANGLE (Degree)	REMARK
*5714	58.89	57.7	68.2	-9.31	31.93	6.69	37.43	185	344	Peak
*5725	60.52	59.24	78.2	-17.68	31.96	6.75	37.43	185	344	Peak
5785	90.19	88.87			32.04	6.82	37.54	185	344	Average
5785	100.64	99.32			32.04	6.82	37.54	185	344	Peak
*5850	60.29	58.77	78.2	-17.91	32.15	6.88	37.51	185	344	Peak
*5861	58.88	57.25	68.2	-9.32	32.18	6.95	37.5	185	344	Peak

REMARKS:

- Emission Level = Read Level + Antenna Factor + Cable Loss - Preamp Factor
Margin value = Emission level – Limit value
- 5785MHz: Fundamental frequency.
- *: Out of restricted band

EUT TEST CONDITION		MEASUREMENT DETAIL	
CHANNEL	Channel 165	FREQUENCY RANGE	1GHz ~ 40GHz
INPUT POWER	120Vac, 60 Hz	DETECTOR FUNCTION	Peak (PK) Average (AV)
ENVIRONMENTAL CONDITIONS	25deg. C, 65%RH	TESTED BY	Gavin Wu

ANTENNA POLARITY & TEST DISTANCE: HORIZONTAL AT 3 M										
FREQ. (MHz)	EMISSION LEVEL (dBuV/m)	READ LEVEL (dBuV)	LIMIT (dBuV/m)	MARGIN (dB)	ANTENNA FACTOR (dB/m)	CABLE LOSS (dB)	PREAMP FACTOR (dB)	ANTENNA HEIGHT (cm)	TABLE ANGLE (Degree)	REMARK
*5714	60.38	59.19	68.2	-7.82	31.93	6.69	37.43	201	245	Peak
*5725	59.76	58.48	78.2	-18.44	31.96	6.75	37.43	201	245	Peak
5825	94.19	92.72			32.12	6.88	37.53	201	245	Average
5825	104.58	103.11			32.12	6.88	37.53	201	245	Peak
*5850	61.04	59.52	78.2	-17.16	32.15	6.88	37.51	201	245	Peak
*5861	59.57	57.94	68.2	-8.63	32.18	6.95	37.5	201	245	Peak
ANTENNA POLARITY & TEST DISTANCE: VERTICAL AT 3 M										
FREQ. (MHz)	EMISSION LEVEL (dBuV/m)	READ LEVEL (dBuV)	LIMIT (dBuV/m)	MARGIN (dB)	ANTENNA FACTOR (dB/m)	CABLE LOSS (dB)	PREAMP FACTOR (dB)	ANTENNA HEIGHT (cm)	TABLE ANGLE (Degree)	REMARK
*5714	58.79	57.6	68.2	-9.41	31.93	6.69	37.43	200	69	Peak
*5725	58.09	56.81	78.2	-20.11	31.96	6.75	37.43	200	69	Peak
5825	90.74	89.27			32.12	6.88	37.53	200	69	Average
5825	100.33	98.86			32.12	6.88	37.53	200	69	Peak
*5850	58.85	57.33	78.2	-19.35	32.15	6.88	37.51	200	69	Peak
*5861	57.69	56.06	68.2	-10.51	32.18	6.95	37.5	200	69	Peak

REMARKS:

- Emission Level = Read Level + Antenna Factor + Cable Loss - Preamp Factor
Margin value = Emission level – Limit value
- 5825MHz: Fundamental frequency.
- *: Out of restricted band

802.11n (40MHz)

EUT TEST CONDITION		MEASUREMENT DETAIL	
CHANNEL	Channel 38	FREQUENCY RANGE	1GHz ~ 40GHz
INPUT POWER	120Vac, 60 Hz	DETECTOR FUNCTION	Peak (PK) Average (AV)
ENVIRONMENTAL CONDITIONS	25deg. C, 65%RH	TESTED BY	Gavin Wu

ANTENNA POLARITY & TEST DISTANCE: HORIZONTAL AT 3 M

FREQ. (MHz)	EMISSION LEVEL (dBuV/m)	READ LEVEL (dBuV)	LIMIT (dBuV/m)	MARGIN (dB)	ANTENNA FACTOR (dB/m)	CABLE LOSS (dB)	PREAMP FACTOR (dB)	ANTENNA HEIGHT (cm)	TABLE ANGLE (Degree)	REMARK
5126	41.76	41.55	54	-12.24	31.31	6.2	37.3	210	233	Average
5126	61.01	60.8	74	-12.99	31.31	6.2	37.3	210	233	Peak
5190	92.03	91.8			31.35	6.22	37.34	210	233	Average
5190	101.57	101.34			31.35	6.22	37.34	210	233	Peak
5398	38.77	38.11	54	-15.23	31.52	6.32	37.18	210	233	Average
5398	60.83	60.17	74	-13.17	31.52	6.32	37.18	210	233	Peak

ANTENNA POLARITY & TEST DISTANCE: VERTICAL AT 3 M

FREQ. (MHz)	EMISSION LEVEL (dBuV/m)	READ LEVEL (dBuV)	LIMIT (dBuV/m)	MARGIN (dB)	ANTENNA FACTOR (dB/m)	CABLE LOSS (dB)	PREAMP FACTOR (dB)	ANTENNA HEIGHT (cm)	TABLE ANGLE (Degree)	REMARK
5056	39.87	39.7	54	-14.13	31.25	6.17	37.25	199	296	Average
5056	61.09	60.92	74	-12.91	31.25	6.17	37.25	199	296	Peak
5190	88.45	88.22			31.35	6.22	37.34	199	296	Average
5190	97.58	97.35			31.35	6.22	37.34	199	296	Peak
5458	38.82	38	54	-15.18	31.56	6.34	37.08	199	296	Average
5458	60.4	59.58	74	-13.6	31.56	6.34	37.08	199	296	Peak

REMARKS:

- Emission Level = Read Level + Antenna Factor + Cable Loss - Preamp Factor
Margin value = Emission level – Limit value
- 5190MHz: Fundamental frequency.

EUT TEST CONDITION		MEASUREMENT DETAIL	
CHANNEL	Channel 46	FREQUENCY RANGE	1GHz ~ 40GHz
INPUT POWER	120Vac, 60 Hz	DETECTOR FUNCTION	Peak (PK) Average (AV)
ENVIRONMENTAL CONDITIONS	25deg. C, 65%RH	TESTED BY	Gavin Wu

ANTENNA POLARITY & TEST DISTANCE: HORIZONTAL AT 3 M										
FREQ. (MHz)	EMISSION LEVEL (dBuV/m)	READ LEVEL (dBuV)	LIMIT (dBuV/m)	MARGIN (dB)	ANTENNA FACTOR (dB/m)	CABLE LOSS (dB)	PREAMP FACTOR (dB)	ANTENNA HEIGHT (cm)	TABLE ANGLE (Degree)	REMARK
5056	39.28	39.11	54	-14.72	31.25	6.17	37.25	209	250	Average
5056	61.25	61.08	74	-12.75	31.25	6.17	37.25	209	250	Peak
5230	92.04	91.73			31.39	6.24	37.32	209	250	Average
5230	101.3	100.99			31.39	6.24	37.32	209	250	Peak
5368	39.07	38.45	54	-14.93	31.49	6.31	37.18	209	250	Average
5368	60.04	59.42	74	-13.96	31.49	6.31	37.18	209	250	Peak
ANTENNA POLARITY & TEST DISTANCE: VERTICAL AT 3 M										
FREQ. (MHz)	EMISSION LEVEL (dBuV/m)	READ LEVEL (dBuV)	LIMIT (dBuV/m)	MARGIN (dB)	ANTENNA FACTOR (dB/m)	CABLE LOSS (dB)	PREAMP FACTOR (dB)	ANTENNA HEIGHT (cm)	TABLE ANGLE (Degree)	REMARK
5128	38.96	38.75	54	-15.04	31.31	6.2	37.3	206	279	Average
5128	61.03	60.82	74	-12.97	31.31	6.2	37.3	206	279	Peak
5230	88.13	87.82			31.39	6.24	37.32	206	279	Average
5230	97.31	97			31.39	6.24	37.32	206	279	Peak
5398	38.65	37.99	54	-15.35	31.52	6.32	37.18	206	279	Average
5398	60.65	59.99	74	-13.35	31.52	6.32	37.18	206	279	Peak

REMARKS:

- Emission Level = Read Level + Antenna Factor + Cable Loss - Preamp Factor
Margin value = Emission level – Limit value
- 5230MHz: Fundamental frequency.



EUT TEST CONDITION		MEASUREMENT DETAIL	
CHANNEL	Channel 54	FREQUENCY RANGE	1GHz ~ 40GHz
INPUT POWER	120Vac, 60 Hz	DETECTOR FUNCTION	Peak (PK) Average (AV)
ENVIRONMENTAL CONDITIONS	25deg. C, 65%RH	TESTED BY	Gavin Wu

ANTENNA POLARITY & TEST DISTANCE: HORIZONTAL AT 3 M										
FREQ. (MHz)	EMISSION LEVEL (dBuV/m)	READ LEVEL (dBuV)	LIMIT (dBuV/m)	MARGIN (dB)	ANTENNA FACTOR (dB/m)	CABLE LOSS (dB)	PREAMP FACTOR (dB)	ANTENNA HEIGHT (cm)	TABLE ANGLE (Degree)	REMARK
5088	38.67	38.48	54	-15.33	31.27	6.19	37.27	130	131	Average
5088	60.27	60.08	74	-13.73	31.27	6.19	37.27	130	131	Peak
5270	92.14	91.75			31.41	6.25	37.27	130	131	Average
5270	101.46	101.07			31.41	6.25	37.27	130	131	Peak
5370	39.53	38.91	54	-14.47	31.49	6.31	37.18	130	131	Average
5370	61.13	60.51	74	-12.87	31.49	6.31	37.18	130	131	Peak
ANTENNA POLARITY & TEST DISTANCE: VERTICAL AT 3 M										
FREQ. (MHz)	EMISSION LEVEL (dBuV/m)	READ LEVEL (dBuV)	LIMIT (dBuV/m)	MARGIN (dB)	ANTENNA FACTOR (dB/m)	CABLE LOSS (dB)	PREAMP FACTOR (dB)	ANTENNA HEIGHT (cm)	TABLE ANGLE (Degree)	REMARK
5028	38.05	37.91	54	-15.95	31.23	6.15	37.24	110	54	Average
5028	59.96	59.82	74	-14.04	31.23	6.15	37.24	110	54	Peak
5270	86.82	86.43			31.41	6.25	37.27	110	54	Average
5270	96.22	95.83			31.41	6.25	37.27	110	54	Peak
5444	38.65	37.89	54	-15.35	31.55	6.34	37.13	110	54	Average
5444	60.63	59.87	74	-13.37	31.55	6.34	37.13	110	54	Peak

REMARKS:

- Emission Level = Read Level + Antenna Factor + Cable Loss - Preamp Factor
Margin value = Emission level – Limit value
- 5270MHz: Fundamental frequency.



A D T

EUT TEST CONDITION		MEASUREMENT DETAIL	
CHANNEL	Channel 62	FREQUENCY RANGE	1GHz ~ 40GHz
INPUT POWER	120Vac, 60 Hz	DETECTOR FUNCTION	Peak (PK) Average (AV)
ENVIRONMENTAL CONDITIONS	25deg. C, 65%RH	TESTED BY	Gavin Wu

ANTENNA POLARITY & TEST DISTANCE: HORIZONTAL AT 3 M										
FREQ. (MHz)	EMISSION LEVEL (dBuV/m)	READ LEVEL (dBuV)	LIMIT (dBuV/m)	MARGIN (dB)	ANTENNA FACTOR (dB/m)	CABLE LOSS (dB)	PREAMP FACTOR (dB)	ANTENNA HEIGHT (cm)	TABLE ANGLE (Degree)	REMARK
5146	38.84	38.64	54	-15.16	31.32	6.2	37.32	140	124	Average
5146	60.59	60.39	74	-13.41	31.32	6.2	37.32	140	124	Peak
5310	92.19	91.66			31.45	6.27	37.19	140	124	Average
5310	101.49	100.96			31.45	6.27	37.19	140	124	Peak
5444	41.52	40.76	54	-12.48	31.55	6.34	37.13	140	124	Average
5444	60.75	59.99	74	-13.25	31.55	6.34	37.13	140	124	Peak

ANTENNA POLARITY & TEST DISTANCE: VERTICAL AT 3 M										
FREQ. (MHz)	EMISSION LEVEL (dBuV/m)	READ LEVEL (dBuV)	LIMIT (dBuV/m)	MARGIN (dB)	ANTENNA FACTOR (dB/m)	CABLE LOSS (dB)	PREAMP FACTOR (dB)	ANTENNA HEIGHT (cm)	TABLE ANGLE (Degree)	REMARK
5042	38.63	38.49	54	-15.37	31.24	6.15	37.25	113	62	Average
5042	59.75	59.61	74	-14.25	31.24	6.15	37.25	113	62	Peak
5310	87.21	86.68			31.45	6.27	37.19	113	62	Average
5310	96.35	95.82			31.45	6.27	37.19	113	62	Peak
5384	39.14	38.5	54	-14.86	31.51	6.31	37.18	113	62	Average
5384	60.76	60.12	74	-13.24	31.51	6.31	37.18	113	62	Peak

REMARKS:

1. Emission Level = Read Level + Antenna Factor + Cable Loss - Preamp Factor
Margin value = Emission level – Limit value
2. 5310MHz: Fundamental frequency.



A D T

EUT TEST CONDITION		MEASUREMENT DETAIL	
CHANNEL	Channel 102	FREQUENCY RANGE	1GHz ~ 40GHz
INPUT POWER	120Vac, 60 Hz	DETECTOR FUNCTION	Peak (PK) Average (AV)
ENVIRONMENTAL CONDITIONS	25deg. C, 65%RH	TESTED BY	Gavin Wu

ANTENNA POLARITY & TEST DISTANCE: HORIZONTAL AT 3 M										
FREQ. (MHz)	EMISSION LEVEL (dBuV/m)	READ LEVEL (dBuV)	LIMIT (dBuV/m)	MARGIN (dB)	ANTENNA FACTOR (dB/m)	CABLE LOSS (dB)	PREAMP FACTOR (dB)	ANTENNA HEIGHT (cm)	TABLE ANGLE (Degree)	REMARK
5382	39.64	39	54	-14.36	31.51	6.31	37.18	194	244	Average
5382	61.29	60.65	74	-12.71	31.51	6.31	37.18	194	244	Peak
5470	58.73	57.9	68.2	-9.47	31.57	6.34	37.08	194	244	Peak
5510	85.01	84.11			31.6	6.36	37.06	194	244	Average
5510	94.36	93.46			31.6	6.36	37.06	194	244	Peak
5725	59.88	58.6	68.2	-8.32	31.96	6.75	37.43	194	244	Peak

ANTENNA POLARITY & TEST DISTANCE: VERTICAL AT 3 M										
FREQ. (MHz)	EMISSION LEVEL (dBuV/m)	READ LEVEL (dBuV)	LIMIT (dBuV/m)	MARGIN (dB)	ANTENNA FACTOR (dB/m)	CABLE LOSS (dB)	PREAMP FACTOR (dB)	ANTENNA HEIGHT (cm)	TABLE ANGLE (Degree)	REMARK
5388	42.58	41.94	54	-11.42	31.51	6.31	37.18	200	218	Average
5388	60.63	59.99	74	-13.37	31.51	6.31	37.18	200	218	Peak
5470	65.18	64.35	68.2	-3.02	31.57	6.34	37.08	200	218	Peak
5510	91.68	90.78			31.6	6.36	37.06	200	218	Average
5510	101.37	100.47			31.6	6.36	37.06	200	218	Peak
5725	61.29	60.01	68.2	-6.91	31.96	6.75	37.43	200	218	Peak

REMARKS:

- Emission Level = Read Level + Antenna Factor + Cable Loss - Preamp Factor
Margin value = Emission level – Limit value
- 5510MHz: Fundamental frequency.
- 5470MHz & 5725MHz: Out of restricted band

EUT TEST CONDITION		MEASUREMENT DETAIL	
CHANNEL	Channel 110	FREQUENCY RANGE	1GHz ~ 40GHz
INPUT POWER	120Vac, 60 Hz	DETECTOR FUNCTION	Peak (PK) Average (AV)
ENVIRONMENTAL CONDITIONS	25deg. C, 65%RH	TESTED BY	Gavin Wu

ANTENNA POLARITY & TEST DISTANCE: HORIZONTAL AT 3 M										
FREQ. (MHz)	EMISSION LEVEL (dBuV/m)	READ LEVEL (dBuV)	LIMIT (dBuV/m)	MARGIN (dB)	ANTENNA FACTOR (dB/m)	CABLE LOSS (dB)	PREAMP FACTOR (dB)	ANTENNA HEIGHT (cm)	TABLE ANGLE (Degree)	REMARK
5368	39.53	38.91	54	-14.47	31.49	6.31	37.18	200	245	Average
5368	60.72	60.1	74	-13.28	31.49	6.31	37.18	200	245	Peak
5470	57.88	57.05	68.2	-10.32	31.57	6.34	37.08	200	245	Peak
5550	85.37	84.36			31.68	6.42	37.09	200	245	Average
5550	94.72	93.71			31.68	6.42	37.09	200	245	Peak
5725	59.15	57.87	68.2	-9.05	31.96	6.75	37.43	200	245	Peak
ANTENNA POLARITY & TEST DISTANCE: VERTICAL AT 3 M										
FREQ. (MHz)	EMISSION LEVEL (dBuV/m)	READ LEVEL (dBuV)	LIMIT (dBuV/m)	MARGIN (dB)	ANTENNA FACTOR (dB/m)	CABLE LOSS (dB)	PREAMP FACTOR (dB)	ANTENNA HEIGHT (cm)	TABLE ANGLE (Degree)	REMARK
5364	40.66	40.04	54	-13.34	31.49	6.31	37.18	198	219	Average
5364	60.57	59.95	74	-13.43	31.49	6.31	37.18	198	219	Peak
5470	59.75	58.92	68.2	-8.45	31.57	6.34	37.08	198	219	Peak
5550	92.31	91.3			31.68	6.42	37.09	198	219	Average
5550	101.61	100.6			31.68	6.42	37.09	198	219	Peak
5725	59.63	58.35	68.2	-8.57	31.96	6.75	37.43	198	219	Peak

REMARKS:

- Emission Level = Read Level + Antenna Factor + Cable Loss - Preamp Factor
Margin value = Emission level – Limit value
- 5550MHz: Fundamental frequency.
- 5470MHz & 5725MHz: Out of restricted band

EUT TEST CONDITION		MEASUREMENT DETAIL	
CHANNEL	Channel 134	FREQUENCY RANGE	1GHz ~ 40GHz
INPUT POWER	120Vac, 60 Hz	DETECTOR FUNCTION	Peak (PK) Average (AV)
ENVIRONMENTAL CONDITIONS	25deg. C, 65%RH	TESTED BY	Gavin Wu

ANTENNA POLARITY & TEST DISTANCE: HORIZONTAL AT 3 M										
FREQ. (MHz)	EMISSION LEVEL (dBuV/m)	READ LEVEL (dBuV)	LIMIT (dBuV/m)	MARGIN (dB)	ANTENNA FACTOR (dB/m)	CABLE LOSS (dB)	PREAMP FACTOR (dB)	ANTENNA HEIGHT (cm)	TABLE ANGLE (Degree)	REMARK
5350	39.09	38.5	54	-14.91	31.48	6.29	37.18	195	245	Average
5350	60.84	60.25	74	-13.16	31.48	6.29	37.18	195	245	Peak
5470	58.44	57.61	68.2	-9.76	31.57	6.34	37.08	195	245	Peak
5670	84.1	82.94			31.88	6.62	37.34	195	245	Average
5670	94.12	92.96			31.88	6.62	37.34	195	245	Peak
5725	59.54	58.26	68.2	-8.66	31.96	6.75	37.43	195	245	Peak
ANTENNA POLARITY & TEST DISTANCE: VERTICAL AT 3 M										
FREQ. (MHz)	EMISSION LEVEL (dBuV/m)	READ LEVEL (dBuV)	LIMIT (dBuV/m)	MARGIN (dB)	ANTENNA FACTOR (dB/m)	CABLE LOSS (dB)	PREAMP FACTOR (dB)	ANTENNA HEIGHT (cm)	TABLE ANGLE (Degree)	REMARK
5428	39.94	39.22	54	-14.06	31.53	6.32	37.13	125	218	Average
5428	60.76	60.04	74	-13.24	31.53	6.32	37.13	125	218	Peak
5470	59.82	58.99	68.2	-8.38	31.57	6.34	37.08	125	218	Peak
5670	92.61	91.45			31.88	6.62	37.34	125	218	Average
5670	101.06	99.9			31.88	6.62	37.34	125	218	Peak
5725	60.58	59.3	68.2	-7.62	31.96	6.75	37.43	125	218	Peak

REMARKS:

- Emission Level = Read Level + Antenna Factor + Cable Loss - Preamp Factor
Margin value = Emission level – Limit value
- 5670MHz: Fundamental frequency.
- 5470MHz & 5725MHz: Out of restricted band



A D T

EUT TEST CONDITION		MEASUREMENT DETAIL	
CHANNEL	Channel 151	FREQUENCY RANGE	1GHz ~ 40GHz
INPUT POWER	120Vac, 60 Hz	DETECTOR FUNCTION	Peak (PK) Average (AV)
ENVIRONMENTAL CONDITIONS	25deg. C, 65%RH	TESTED BY	Gavin Wu

ANTENNA POLARITY & TEST DISTANCE: HORIZONTAL AT 3 M										
FREQ. (MHz)	EMISSION LEVEL (dBuV/m)	READ LEVEL (dBuV)	LIMIT (dBuV/m)	MARGIN (dB)	ANTENNA FACTOR (dB/m)	CABLE LOSS (dB)	PREAMP FACTOR (dB)	ANTENNA HEIGHT (cm)	TABLE ANGLE (Degree)	REMARK
*5714	62.89	61.7	68.2	-5.31	31.93	6.69	37.43	192	238	Peak
*5725	66.62	65.34	78.2	-11.58	31.96	6.75	37.43	192	238	Peak
5755	92.72	91.43			32.01	6.75	37.47	192	238	Average
5755	102.83	101.54			32.01	6.75	37.47	192	238	Peak
*5850	60.42	58.9	78.2	-17.78	32.15	6.88	37.51	192	238	Peak
*5861	61.41	59.78	68.2	-6.79	32.18	6.95	37.5	192	238	Peak
ANTENNA POLARITY & TEST DISTANCE: VERTICAL AT 3 M										
FREQ. (MHz)	EMISSION LEVEL (dBuV/m)	READ LEVEL (dBuV)	LIMIT (dBuV/m)	MARGIN (dB)	ANTENNA FACTOR (dB/m)	CABLE LOSS (dB)	PREAMP FACTOR (dB)	ANTENNA HEIGHT (cm)	TABLE ANGLE (Degree)	REMARK
*5714	58.89	57.7	68.2	-9.31	31.93	6.69	37.43	205	342	Peak
*5725	60.71	59.43	78.2	-17.49	31.96	6.75	37.43	205	342	Peak
5755	88.12	86.83			32.01	6.75	37.47	205	342	Average
5755	98.81	97.52			32.01	6.75	37.47	205	342	Peak
*5850	60.15	58.63	78.2	-18.05	32.15	6.88	37.51	205	342	Peak
*5861	60.78	59.15	68.2	-7.42	32.18	6.95	37.5	205	342	Peak

REMARKS:

- Emission Level = Read Level + Antenna Factor + Cable Loss - Preamp Factor
Margin value = Emission level – Limit value
- 5755MHz: Fundamental frequency.
- *: Out of restricted band



A D T

EUT TEST CONDITION		MEASUREMENT DETAIL	
CHANNEL	Channel 159	FREQUENCY RANGE	1GHz ~ 40GHz
INPUT POWER	120Vac, 60 Hz	DETECTOR FUNCTION	Peak (PK) Average (AV)
ENVIRONMENTAL CONDITIONS	25deg. C, 65%RH	TESTED BY	Gavin Wu

ANTENNA POLARITY & TEST DISTANCE: HORIZONTAL AT 3 M										
FREQ. (MHz)	EMISSION LEVEL (dBuV/m)	READ LEVEL (dBuV)	LIMIT (dBuV/m)	MARGIN (dB)	ANTENNA FACTOR (dB/m)	CABLE LOSS (dB)	PREAMP FACTOR (dB)	ANTENNA HEIGHT (cm)	TABLE ANGLE (Degree)	REMARK
*5714	59.49	58.3	68.2	-8.71	31.93	6.69	37.43	186	238	Peak
*5725	58.78	57.5	78.2	-19.42	31.96	6.75	37.43	186	238	Peak
5795	92.39	91.04			32.07	6.82	37.54	186	238	Average
5795	102.63	101.28			32.07	6.82	37.54	186	238	Peak
*5850	58.52	57	78.2	-19.68	32.15	6.88	37.51	186	238	Peak
*5861	59.22	57.59	68.2	-8.98	32.18	6.95	37.5	186	238	Peak
ANTENNA POLARITY & TEST DISTANCE: VERTICAL AT 3 M										
FREQ. (MHz)	EMISSION LEVEL (dBuV/m)	READ LEVEL (dBuV)	LIMIT (dBuV/m)	MARGIN (dB)	ANTENNA FACTOR (dB/m)	CABLE LOSS (dB)	PREAMP FACTOR (dB)	ANTENNA HEIGHT (cm)	TABLE ANGLE (Degree)	REMARK
*5714	60.83	59.64	68.2	-7.37	31.93	6.69	37.43	167	172	Peak
*5725	60.13	58.85	78.2	-18.07	31.96	6.75	37.43	167	172	Peak
5795	88.54	87.19			32.07	6.82	37.54	167	172	Average
5795	98.54	97.19			32.07	6.82	37.54	167	172	Peak
*5850	61.18	59.66	78.2	-17.02	32.15	6.88	37.51	167	172	Peak
*5861	60.57	58.94	68.2	-7.63	32.18	6.95	37.5	167	172	Peak

REMARKS:

- Emission Level = Read Level + Antenna Factor + Cable Loss - Preamp Factor
Margin value = Emission level – Limit value
- 5795MHz: Fundamental frequency.
- *: Out of restricted band

802.11ac (80MHz)

EUT TEST CONDITION		MEASUREMENT DETAIL	
CHANNEL	Channel 42	FREQUENCY RANGE	1GHz ~ 40GHz
INPUT POWER	120Vac, 60 Hz	DETECTOR FUNCTION	Peak (PK) Average (AV)
ENVIRONMENTAL CONDITIONS	25deg. C, 65%RH	TESTED BY	Gavin Wu

ANTENNA POLARITY & TEST DISTANCE: HORIZONTAL AT 3 M

FREQ. (MHz)	EMISSION LEVEL (dBuV/m)	READ LEVEL (dBuV)	LIMIT (dBuV/m)	MARGIN (dB)	ANTENNA FACTOR (dB/m)	CABLE LOSS (dB)	PREAMP FACTOR (dB)	ANTENNA HEIGHT (cm)	TABLE ANGLE (Degree)	REMARK
5138	47.62	47.41	54	-6.38	31.31	6.2	37.3	208	237	Average
5138	61.84	61.63	74	-12.16	31.31	6.2	37.3	208	237	Peak
5210	87.62	87.37			31.37	6.24	37.36	208	237	Average
5210	97.31	97.06			31.37	6.24	37.36	208	237	Peak
5404	39.17	38.51	54	-14.83	31.52	6.32	37.18	208	237	Average
5404	59.95	59.29	74	-14.05	31.52	6.32	37.18	208	237	Peak

ANTENNA POLARITY & TEST DISTANCE: VERTICAL AT 3 M

FREQ. (MHz)	EMISSION LEVEL (dBuV/m)	READ LEVEL (dBuV)	LIMIT (dBuV/m)	MARGIN (dB)	ANTENNA FACTOR (dB/m)	CABLE LOSS (dB)	PREAMP FACTOR (dB)	ANTENNA HEIGHT (cm)	TABLE ANGLE (Degree)	REMARK
5096	43.91	43.72	54	-10.09	31.28	6.19	37.28	207	269	Average
5096	60.62	60.43	74	-13.38	31.28	6.19	37.28	207	269	Peak
5210	83.81	83.56			31.37	6.24	37.36	207	269	Average
5210	93.15	92.9			31.37	6.24	37.36	207	269	Peak
5380	38.87	38.23	54	-15.13	31.51	6.31	37.18	207	269	Average
5380	60.49	59.85	74	-13.51	31.51	6.31	37.18	207	269	Peak

REMARKS:

- Emission Level = Read Level + Antenna Factor + Cable Loss - Preamp Factor
Margin value = Emission level – Limit value
- 5210MHz: Fundamental frequency.

EUT TEST CONDITION		MEASUREMENT DETAIL	
CHANNEL	Channel 58	FREQUENCY RANGE	1GHz ~ 40GHz
INPUT POWER	120Vac, 60 Hz	DETECTOR FUNCTION	Peak (PK) Average (AV)
ENVIRONMENTAL CONDITIONS	25deg. C, 65%RH	TESTED BY	Gavin Wu

ANTENNA POLARITY & TEST DISTANCE: HORIZONTAL AT 3 M										
FREQ. (MHz)	EMISSION LEVEL (dBuV/m)	READ LEVEL (dBuV)	LIMIT (dBuV/m)	MARGIN (dB)	ANTENNA FACTOR (dB/m)	CABLE LOSS (dB)	PREAMP FACTOR (dB)	ANTENNA HEIGHT (cm)	TABLE ANGLE (Degree)	REMARK
5120	39.02	38.84	54	-14.98	31.29	6.19	37.3	133	112	Average
5120	59.76	59.58	74	-14.24	31.29	6.19	37.3	133	112	Peak
5290	87.93	87.46			31.43	6.27	37.23	133	112	Average
5290	97.62	97.15			31.43	6.27	37.23	133	112	Peak
5366	45.48	44.86	54	-8.52	31.49	6.31	37.18	133	112	Average
5366	63.2	62.58	74	-10.8	31.49	6.31	37.18	133	112	Peak
ANTENNA POLARITY & TEST DISTANCE: VERTICAL AT 3 M										
FREQ. (MHz)	EMISSION LEVEL (dBuV/m)	READ LEVEL (dBuV)	LIMIT (dBuV/m)	MARGIN (dB)	ANTENNA FACTOR (dB/m)	CABLE LOSS (dB)	PREAMP FACTOR (dB)	ANTENNA HEIGHT (cm)	TABLE ANGLE (Degree)	REMARK
5028	38.95	38.81	54	-15.05	31.23	6.15	37.24	114	62	Average
5028	60.49	60.35	74	-13.51	31.23	6.15	37.24	114	62	Peak
5290	83.12	82.65			31.43	6.27	37.23	114	62	Average
5290	93.4	92.93			31.43	6.27	37.23	114	62	Peak
5422	39.99	39.32	54	-14.01	31.53	6.32	37.18	114	62	Average
5422	60.28	59.61	74	-13.72	31.53	6.32	37.18	114	62	Peak

REMARKS:

- Emission Level = Read Level + Antenna Factor + Cable Loss - Preamp Factor
Margin value = Emission level – Limit value
- 5290MHz: Fundamental frequency.



EUT TEST CONDITION		MEASUREMENT DETAIL	
CHANNEL	Channel 106	FREQUENCY RANGE	1GHz ~ 40GHz
INPUT POWER	120Vac, 60 Hz	DETECTOR FUNCTION	Peak (PK) Average (AV)
ENVIRONMENTAL CONDITIONS	25deg. C, 65%RH	TESTED BY	Gavin Wu

ANTENNA POLARITY & TEST DISTANCE: HORIZONTAL AT 3 M										
FREQ. (MHz)	EMISSION LEVEL (dBuV/m)	READ LEVEL (dBuV)	LIMIT (dBuV/m)	MARGIN (dB)	ANTENNA FACTOR (dB/m)	CABLE LOSS (dB)	PREAMP FACTOR (dB)	ANTENNA HEIGHT (cm)	TABLE ANGLE (Degree)	REMARK
5460	43.25	42.43	54	-10.75	31.56	6.34	37.08	219	240	Average
5460	61.87	61.05	74	-12.13	31.56	6.34	37.08	219	240	Peak
5470	62	61.17	68.2	-6.2	31.57	6.34	37.08	219	240	Peak
5530	83.49	82.53			31.63	6.42	37.09	219	240	Average
5530	93.95	92.99			31.63	6.42	37.09	219	240	Peak
5725	59.93	58.65	68.2	-8.27	31.96	6.75	37.43	219	240	Peak
ANTENNA POLARITY & TEST DISTANCE: VERTICAL AT 3 M										
FREQ. (MHz)	EMISSION LEVEL (dBuV/m)	READ LEVEL (dBuV)	LIMIT (dBuV/m)	MARGIN (dB)	ANTENNA FACTOR (dB/m)	CABLE LOSS (dB)	PREAMP FACTOR (dB)	ANTENNA HEIGHT (cm)	TABLE ANGLE (Degree)	REMARK
5454	45.5	44.68	54	-8.5	31.56	6.34	37.08	115	225	Average
5454	62.52	61.7	74	-11.48	31.56	6.34	37.08	115	225	Peak
5470	63.54	62.71	68.2	-4.66	31.57	6.34	37.08	115	225	Peak
5530	89.31	88.35			31.63	6.42	37.09	115	225	Average
5530	99.18	98.22			31.63	6.42	37.09	115	225	Peak
5725	59.7	58.42	68.2	-8.5	31.96	6.75	37.43	115	225	Peak

REMARKS:

- Emission Level = Read Level + Antenna Factor + Cable Loss - Preamp Factor
Margin value = Emission level – Limit value
- 5530MHz: Fundamental frequency.
- 5470MHz & 5725MHz: Out of restricted band

EUT TEST CONDITION		MEASUREMENT DETAIL	
CHANNEL	Channel 122	FREQUENCY RANGE	1GHz ~ 40GHz
INPUT POWER	120Vac, 60 Hz	DETECTOR FUNCTION	Peak (PK) Average (AV)
ENVIRONMENTAL CONDITIONS	25deg. C, 65%RH	TESTED BY	Gavin Wu

ANTENNA POLARITY & TEST DISTANCE: HORIZONTAL AT 3 M										
FREQ. (MHz)	EMISSION LEVEL (dBuV/m)	READ LEVEL (dBuV)	LIMIT (dBuV/m)	MARGIN (dB)	ANTENNA FACTOR (dB/m)	CABLE LOSS (dB)	PREAMP FACTOR (dB)	ANTENNA HEIGHT (cm)	TABLE ANGLE (Degree)	REMARK
5404	39.33	38.67	54	-14.67	31.52	6.32	37.18	208	240	Average
5404	60.31	59.65	74	-13.69	31.52	6.32	37.18	208	240	Peak
5470	59.75	58.92	68.2	-8.45	31.57	6.34	37.08	208	240	Peak
5610	84.06	82.95			31.77	6.56	37.22	208	240	Average
5610	94.11	93			31.77	6.56	37.22	208	240	Peak
5725	58.51	57.23	68.2	-9.69	31.96	6.75	37.43	208	240	Peak
ANTENNA POLARITY & TEST DISTANCE: VERTICAL AT 3 M										
FREQ. (MHz)	EMISSION LEVEL (dBuV/m)	READ LEVEL (dBuV)	LIMIT (dBuV/m)	MARGIN (dB)	ANTENNA FACTOR (dB/m)	CABLE LOSS (dB)	PREAMP FACTOR (dB)	ANTENNA HEIGHT (cm)	TABLE ANGLE (Degree)	REMARK
5370	39.36	38.74	54	-14.64	31.49	6.31	37.18	100	226	Average
5370	60.27	59.65	74	-13.73	31.49	6.31	37.18	100	226	Peak
5470	58.75	57.92	68.2	-9.45	31.57	6.34	37.08	100	226	Peak
5610	90.25	89.14			31.77	6.56	37.22	100	226	Average
5610	100.46	99.35			31.77	6.56	37.22	100	226	Peak
5725	59.33	58.05	68.2	-8.87	31.96	6.75	37.43	100	226	Peak

REMARKS:

- Emission Level = Read Level + Antenna Factor + Cable Loss - Preamp Factor
Margin value = Emission level – Limit value
- 5610MHz: Fundamental frequency.
- 5470MHz & 5725MHz: Out of restricted band

EUT TEST CONDITION		MEASUREMENT DETAIL	
CHANNEL	Channel 155	FREQUENCY RANGE	1GHz ~ 40GHz
INPUT POWER	120Vac, 60 Hz	DETECTOR FUNCTION	Peak (PK) Average (AV)
ENVIRONMENTAL CONDITIONS	25deg. C, 65%RH	TESTED BY	Gavin Wu

ANTENNA POLARITY & TEST DISTANCE: HORIZONTAL AT 3 M										
FREQ. (MHz)	EMISSION LEVEL (dBuV/m)	READ LEVEL (dBuV)	LIMIT (dBuV/m)	MARGIN (dB)	ANTENNA FACTOR (dB/m)	CABLE LOSS (dB)	PREAMP FACTOR (dB)	ANTENNA HEIGHT (cm)	TABLE ANGLE (Degree)	REMARK
*5714	65.22	64.03	68.2	-2.98	31.93	6.69	37.43	193	239	Peak
*5725	66.61	65.33	78.2	-11.59	31.96	6.75	37.43	193	239	Peak
5775	88.81	87.45			32.04	6.82	37.5	193	239	Average
5775	98.8	97.44			32.04	6.82	37.5	193	239	Peak
*5850	60.14	58.62	78.2	-18.06	32.15	6.88	37.51	193	239	Peak
*5861	59.48	57.85	68.2	-8.72	32.18	6.95	37.5	193	239	Peak
ANTENNA POLARITY & TEST DISTANCE: VERTICAL AT 3 M										
FREQ. (MHz)	EMISSION LEVEL (dBuV/m)	READ LEVEL (dBuV)	LIMIT (dBuV/m)	MARGIN (dB)	ANTENNA FACTOR (dB/m)	CABLE LOSS (dB)	PREAMP FACTOR (dB)	ANTENNA HEIGHT (cm)	TABLE ANGLE (Degree)	REMARK
*5714	60.54	59.35	68.2	-7.66	31.93	6.69	37.43	183	41	Peak
*5725	61.18	59.9	78.2	-17.02	31.96	6.75	37.43	183	41	Peak
5775	84.26	82.9			32.04	6.82	37.5	183	41	Average
5775	94.38	93.02			32.04	6.82	37.5	183	41	Peak
*5850	59.59	58.07	78.2	-18.61	32.15	6.88	37.51	183	41	Peak
*5861	59.11	57.48	68.2	-9.09	32.18	6.95	37.5	183	41	Peak

REMARKS:

- Emission Level = Read Level + Antenna Factor + Cable Loss - Preamp Factor
Margin value = Emission level – Limit value
- 5775MHz: Fundamental frequency.
- *: Out of restricted band

MODE B
802.11ac (80MHz)

EUT TEST CONDITION		MEASUREMENT DETAIL	
CHANNEL	Channel 42	FREQUENCY RANGE	1GHz ~ 40GHz
INPUT POWER	120Vac, 60 Hz	DETECTOR FUNCTION	Peak (PK) Average (AV)
ENVIRONMENTAL CONDITIONS	25deg. C, 65%RH	TESTED BY	Gavin Wu

ANTENNA POLARITY & TEST DISTANCE: HORIZONTAL AT 3 M										
FREQ. (MHz)	EMISSION LEVEL (dBuV/m)	READ LEVEL (dBuV)	LIMIT (dBuV/m)	MARGIN (dB)	ANTENNA FACTOR (dB/m)	CABLE LOSS (dB)	PREAMP FACTOR (dB)	ANTENNA HEIGHT (cm)	TABLE ANGLE (Degree)	REMARK
5144	45.98	45.78	54	-8.02	31.32	6.2	37.32	188	242	Average
5144	62.31	62.11	74	-11.69	31.32	6.2	37.32	188	242	Peak
5210	87.65	87.4			31.37	6.24	37.36	188	242	Average
5210	97.61	97.36			31.37	6.24	37.36	188	242	Peak
5454	39.36	38.54	54	-14.64	31.56	6.34	37.08	188	242	Average
5454	60.14	59.32	74	-13.86	31.56	6.34	37.08	188	242	Peak

ANTENNA POLARITY & TEST DISTANCE: VERTICAL AT 3 M										
FREQ. (MHz)	EMISSION LEVEL (dBuV/m)	READ LEVEL (dBuV)	LIMIT (dBuV/m)	MARGIN (dB)	ANTENNA FACTOR (dB/m)	CABLE LOSS (dB)	PREAMP FACTOR (dB)	ANTENNA HEIGHT (cm)	TABLE ANGLE (Degree)	REMARK
5070	41.9	41.75	54	-12.1	31.25	6.17	37.27	174	25	Average
5070	59.82	59.67	74	-14.18	31.25	6.17	37.27	174	25	Peak
5210	82.08	81.83			31.37	6.24	37.36	174	25	Average
5210	91.33	91.08			31.37	6.24	37.36	174	25	Peak
5428	38.8	38.08	54	-15.2	31.53	6.32	37.13	174	25	Average
5428	60.93	60.21	74	-13.07	31.53	6.32	37.13	174	25	Peak

REMARKS:

- Emission Level = Read Level + Antenna Factor + Cable Loss - Preamp Factor
Margin value = Emission level – Limit value
- 5210MHz: Fundamental frequency.

802.11ac (80MHz)

EUT TEST CONDITION		MEASUREMENT DETAIL	
CHANNEL	Channel 58	FREQUENCY RANGE	1GHz ~ 40GHz
INPUT POWER	120Vac, 60 Hz	DETECTOR FUNCTION	Peak (PK) Average (AV)
ENVIRONMENTAL CONDITIONS	25deg. C, 65%RH	TESTED BY	Gavin Wu

ANTENNA POLARITY & TEST DISTANCE: HORIZONTAL AT 3 M

FREQ. (MHz)	EMISSION LEVEL (dBuV/m)	READ LEVEL (dBuV)	LIMIT (dBuV/m)	MARGIN (dB)	ANTENNA FACTOR (dB/m)	CABLE LOSS (dB)	PREAMP FACTOR (dB)	ANTENNA HEIGHT (cm)	TABLE ANGLE (Degree)	REMARK
5078	39.79	39.62	54	-14.21	31.27	6.17	37.27	162	212	Average
5078	59.84	59.67	74	-14.16	31.27	6.17	37.27	162	212	Peak
5290	87.98	87.51			31.43	6.27	37.23	162	212	Average
5290	98.11	97.64			31.43	6.27	37.23	162	212	Peak
5372	45.43	44.81	54	-8.57	31.49	6.31	37.18	162	212	Average
5372	63.39	62.77	74	-10.61	31.49	6.31	37.18	162	212	Peak

ANTENNA POLARITY & TEST DISTANCE: VERTICAL AT 3 M

FREQ. (MHz)	EMISSION LEVEL (dBuV/m)	READ LEVEL (dBuV)	LIMIT (dBuV/m)	MARGIN (dB)	ANTENNA FACTOR (dB/m)	CABLE LOSS (dB)	PREAMP FACTOR (dB)	ANTENNA HEIGHT (cm)	TABLE ANGLE (Degree)	REMARK
5146	38.78	38.58	54	-15.22	31.32	6.2	37.32	197	277	Average
5146	59.61	59.41	74	-14.39	31.32	6.2	37.32	197	277	Peak
5290	82.75	82.28			31.43	6.27	37.23	197	277	Average
5290	92.09	91.62			31.43	6.27	37.23	197	277	Peak
5362	43.21	42.59	54	-10.79	31.49	6.31	37.18	197	277	Average
5362	60.9	60.28	74	-13.1	31.49	6.31	37.18	197	277	Peak

REMARKS:

- Emission Level = Read Level + Antenna Factor + Cable Loss - Preamp Factor
Margin value = Emission level – Limit value
- 5290MHz: Fundamental frequency.

802.11a

EUT TEST CONDITION		MEASUREMENT DETAIL	
CHANNEL	Channel 140	FREQUENCY RANGE	1GHz ~ 40GHz
INPUT POWER	120Vac, 60 Hz	DETECTOR FUNCTION	Peak (PK) Average (AV)
ENVIRONMENTAL CONDITIONS	25deg. C, 65%RH	TESTED BY	Gavin Wu

ANTENNA POLARITY & TEST DISTANCE: HORIZONTAL AT 3 M

FREQ. (MHz)	EMISSION LEVEL (dBuV/m)	READ LEVEL (dBuV)	LIMIT (dBuV/m)	MARGIN (dB)	ANTENNA FACTOR (dB/m)	CABLE LOSS (dB)	PREAMP FACTOR (dB)	ANTENNA HEIGHT (cm)	TABLE ANGLE (Degree)	REMARK
5420	38.15	37.48	54	-15.85	31.53	6.32	37.18	172	42	Average
5420	60.66	59.99	74	-13.34	31.53	6.32	37.18	172	42	Peak
5470	57.87	57.04	68.2	-10.33	31.57	6.34	37.08	172	42	Peak
5700	87.52	86.33			31.9	6.69	37.4	172	42	Average
5700	97.07	95.88			31.9	6.69	37.4	172	42	Peak
5725	59.07	57.79	68.2	-9.13	31.96	6.75	37.43	172	42	Peak

ANTENNA POLARITY & TEST DISTANCE: VERTICAL AT 3 M

FREQ. (MHz)	EMISSION LEVEL (dBuV/m)	READ LEVEL (dBuV)	LIMIT (dBuV/m)	MARGIN (dB)	ANTENNA FACTOR (dB/m)	CABLE LOSS (dB)	PREAMP FACTOR (dB)	ANTENNA HEIGHT (cm)	TABLE ANGLE (Degree)	REMARK
5374	39.32	38.7	54	-14.68	31.49	6.31	37.18	191	171	Average
5374	60.27	59.65	74	-13.73	31.49	6.31	37.18	191	171	Peak
5470	58.17	57.34	68.2	-10.03	31.57	6.34	37.08	191	171	Peak
5700	94.35	93.16			31.9	6.69	37.4	191	171	Average
5700	104.17	102.98			31.9	6.69	37.4	191	171	Peak
5725	62.6	61.32	68.2	-5.6	31.96	6.75	37.43	191	171	Peak

REMARKS:

- Emission Level = Read Level + Antenna Factor + Cable Loss - Preamp Factor
Margin value = Emission level – Limit value
- 5700MHz: Fundamental frequency.
- 5470MHz & 5725MHz: Out of restricted band

802.11ac (80MHz)

EUT TEST CONDITION		MEASUREMENT DETAIL	
CHANNEL	Channel 155	FREQUENCY RANGE	1GHz ~ 40GHz
INPUT POWER	120Vac, 60 Hz	DETECTOR FUNCTION	Peak (PK) Average (AV)
ENVIRONMENTAL CONDITIONS	25deg. C, 65%RH	TESTED BY	Gavin Wu

ANTENNA POLARITY & TEST DISTANCE: HORIZONTAL AT 3 M

FREQ. (MHz)	EMISSION LEVEL (dBuV/m)	READ LEVEL (dBuV)	LIMIT (dBuV/m)	MARGIN (dB)	ANTENNA FACTOR (dB/m)	CABLE LOSS (dB)	PREAMP FACTOR (dB)	ANTENNA HEIGHT (cm)	TABLE ANGLE (Degree)	REMARK
*5714	64.36	63.17	68.2	-3.84	31.93	6.69	37.43	189	75	Peak
*5725	66.57	65.29	78.2	-11.63	31.96	6.75	37.43	189	75	Peak
5775	89.63	88.27			32.04	6.82	37.5	189	75	Average
5775	99.26	97.9			32.04	6.82	37.5	189	75	Peak
*5850	62.44	60.92	78.2	-15.76	32.15	6.88	37.51	189	75	Peak
*5861	61.45	59.82	68.2	-6.75	32.18	6.95	37.5	189	75	Peak

ANTENNA POLARITY & TEST DISTANCE: VERTICAL AT 3 M

FREQ. (MHz)	EMISSION LEVEL (dBuV/m)	READ LEVEL (dBuV)	LIMIT (dBuV/m)	MARGIN (dB)	ANTENNA FACTOR (dB/m)	CABLE LOSS (dB)	PREAMP FACTOR (dB)	ANTENNA HEIGHT (cm)	TABLE ANGLE (Degree)	REMARK
*5714	61.01	59.82	68.2	-7.19	31.93	6.69	37.43	209	259	Peak
*5725	61.35	60.07	78.2	-16.85	31.96	6.75	37.43	209	259	Peak
5775	82.19	80.83			32.04	6.82	37.5	209	259	Average
5775	91.7	90.34			32.04	6.82	37.5	209	259	Peak
*5850	61.36	59.84	78.2	-16.84	32.15	6.88	37.51	209	259	Peak
*5861	59.69	58.06	68.2	-8.51	32.18	6.95	37.5	209	259	Peak

REMARKS:

- Emission Level = Read Level + Antenna Factor + Cable Loss - Preamp Factor
Margin value = Emission level – Limit value
- 5775MHz: Fundamental frequency.
- *: Out of restricted band



A D T

9kHz ~ 30MHz DATA:

The amplitude of spurious emissions attenuated more than 20dB below the permissible value is not required to be report.

30MHz ~ 1GHz WORST-CASE DATA:

MODE A

802.11ac (80MHz)

EUT TEST CONDITION		MEASUREMENT DETAIL	
CHANNEL	Channel 42	FREQUENCY RANGE	30MHz ~ 1GHz
INPUT POWER	120Vac, 60 Hz	DETECTOR FUNCTION	Peak (PK) Quasi-peak (QP)
ENVIRONMENTAL CONDITIONS	25deg. C, 65%RH	TESTED BY	Gavin Wu

ANTENNA POLARITY & TEST DISTANCE: HORIZONTAL AT 3 M										
FREQ. (MHz)	EMISSION LEVEL (dBuV/m)	READ LEVEL (dBuV)	LIMIT (dBuV/m)	MARGIN (dB)	ANTENNA FACTOR (dB/m)	CABLE LOSS (dB)	PREAMP FACTOR (dB)	ANTENNA HEIGHT (cm)	TABLE ANGLE (Degree)	REMARK
304.51	31.82	49	46	-14.18	13.06	1.65	31.89	115	90	Peak
412.18	33.64	48.13	46	-12.36	15.58	1.93	32	137	233	Peak
495.6	27.75	40.13	46	-18.25	17.23	2.08	31.69	137	158	Peak
696.39	29.66	38.25	46	-16.34	20.77	2.45	31.81	112	357	Peak
773.02	30.01	36.93	46	-15.99	21.85	2.57	31.34	137	118	Peak
797.27	31.71	38.33	46	-14.29	22.19	2.61	31.42	102	220	Peak
ANTENNA POLARITY & TEST DISTANCE: VERTICAL AT 3 M										
FREQ. (MHz)	EMISSION LEVEL (dBuV/m)	READ LEVEL (dBuV)	LIMIT (dBuV/m)	MARGIN (dB)	ANTENNA FACTOR (dB/m)	CABLE LOSS (dB)	PREAMP FACTOR (dB)	ANTENNA HEIGHT (cm)	TABLE ANGLE (Degree)	REMARK
216.24	23.97	44.22	46	-22.03	10.05	1.36	31.66	113	116	Peak
424.79	27.93	42.18	46	-18.07	15.83	1.95	32.03	128	120	Peak
443.22	28.32	42.13	46	-17.68	16.2	1.98	31.99	137	1	Peak
612	33.31	43.38	46	-12.69	19.75	2.28	32.1	140	221	Peak
796.3	30.86	37.49	46	-15.14	22.18	2.61	31.42	105	28	Peak
879.72	35.37	41.37	46	-10.63	23.25	2.73	31.98	138	189	Peak

REMARKS: Emission Level = Read Level + Antenna Factor + Cable Loss - Preamp Factor

Margin value = Emission level – Limit value

**802.11ac (80MHz)**

EUT TEST CONDITION		MEASUREMENT DETAIL	
CHANNEL	Channel 58	FREQUENCY RANGE	30MHz ~ 1GHz
INPUT POWER	120Vac, 60 Hz	DETECTOR FUNCTION	Peak (PK) Quasi-peak (QP)
ENVIRONMENTAL CONDITIONS	25deg. C, 65%RH	TESTED BY	Gavin Wu

ANTENNA POLARITY & TEST DISTANCE: HORIZONTAL AT 3 M

FREQ. (MHz)	EMISSION LEVEL (dBuV/m)	READ LEVEL (dBuV)	LIMIT (dBuV/m)	MARGIN (dB)	ANTENNA FACTOR (dB/m)	CABLE LOSS (dB)	PREAMP FACTOR (dB)	ANTENNA HEIGHT (cm)	TABLE ANGLE (Degree)	REMARK
304.51	31.28	48.46	46	-14.72	13.06	1.65	31.89	102	133	Peak
387.93	31.19	46.28	46	-14.81	15.05	1.88	32.02	127	349	Peak
434.49	28.2	42.23	46	-17.8	16.02	1.96	32.01	140	129	Peak
586.78	30.04	40.63	46	-15.96	19.3	2.24	32.13	120	104	Peak
612	30.16	40.23	46	-15.84	19.75	2.28	32.1	133	60	Peak
684.75	30.02	38.8	46	-15.98	20.63	2.43	31.84	105	0	Peak

ANTENNA POLARITY & TEST DISTANCE: VERTICAL AT 3 M

FREQ. (MHz)	EMISSION LEVEL (dBuV/m)	READ LEVEL (dBuV)	LIMIT (dBuV/m)	MARGIN (dB)	ANTENNA FACTOR (dB/m)	CABLE LOSS (dB)	PREAMP FACTOR (dB)	ANTENNA HEIGHT (cm)	TABLE ANGLE (Degree)	REMARK
424.79	29.47	43.72	46	-16.53	15.83	1.95	32.03	115	76	Peak
433.52	28.73	42.78	46	-17.27	16	1.96	32.01	100	317	Peak
573.2	31.16	42.04	46	-14.84	18.99	2.22	32.09	105	345	Peak
588.72	32.82	43.38	46	-13.18	19.34	2.24	32.14	103	160	Peak
609.09	34.16	44.26	46	-11.84	19.72	2.28	32.1	121	50	Peak
762.35	30.28	37.45	46	-15.72	21.7	2.55	31.42	134	256	Peak

REMARKS: Emission Level = Read Level + Antenna Factor + Cable Loss - Preamp Factor

Margin value = Emission level – Limit value



A D T

802.11a

EUT TEST CONDITION		MEASUREMENT DETAIL	
CHANNEL	Channel 140	FREQUENCY RANGE	30MHz ~ 1GHz
INPUT POWER	120Vac, 60 Hz	DETECTOR FUNCTION	Peak (PK) Quasi-peak (QP)
ENVIRONMENTAL CONDITIONS	25deg. C, 65%RH	TESTED BY	Gavin Wu

ANTENNA POLARITY & TEST DISTANCE: HORIZONTAL AT 3 M

FREQ. (MHz)	EMISSION LEVEL (dBuV/m)	READ LEVEL (dBuV)	LIMIT (dBuV/m)	MARGIN (dB)	ANTENNA FACTOR (dB/m)	CABLE LOSS (dB)	PREAMP FACTOR (dB)	ANTENNA HEIGHT (cm)	TABLE ANGLE (Degree)	REMARK
304.51	30.94	48.12	46	-15.06	13.06	1.65	31.89	106	128	Peak
420.91	32.3	46.66	46	-13.7	15.75	1.94	32.05	124	93	Peak
489.78	28.26	40.84	46	-17.74	17.12	2.07	31.77	140	147	Peak
609.09	29.56	39.66	46	-16.44	19.72	2.28	32.1	111	78	Peak
739.07	30.9	38.5	46	-15.1	21.37	2.52	31.49	106	58	Peak
775.93	33.98	40.89	46	-12.02	21.89	2.58	31.38	132	249	Peak

ANTENNA POLARITY & TEST DISTANCE: VERTICAL AT 3 M

FREQ. (MHz)	EMISSION LEVEL (dBuV/m)	READ LEVEL (dBuV)	LIMIT (dBuV/m)	MARGIN (dB)	ANTENNA FACTOR (dB/m)	CABLE LOSS (dB)	PREAMP FACTOR (dB)	ANTENNA HEIGHT (cm)	TABLE ANGLE (Degree)	REMARK
422.85	29.24	43.55	46	-16.76	15.79	1.94	32.04	113	332	Peak
432.55	28.78	42.85	46	-17.22	15.98	1.96	32.01	108	205	Peak
576.11	30.72	41.54	46	-15.28	19.06	2.22	32.1	114	281	Peak
610.06	35.96	46.03	46	-10.04	19.73	2.28	32.08	129	354	Peak
647.89	30.65	40.14	46	-15.35	20.19	2.35	32.03	117	343	Peak
763.32	29.74	36.89	46	-16.26	21.71	2.55	31.41	115	296	Peak

REMARKS: Emission Level = Read Level + Antenna Factor + Cable Loss - Preamp Factor

Margin value = Emission level – Limit value

**802.11ac (80MHz)**

EUT TEST CONDITION		MEASUREMENT DETAIL	
CHANNEL	Channel 155	FREQUENCY RANGE	30MHz ~ 1GHz
INPUT POWER	120Vac, 60 Hz	DETECTOR FUNCTION	Peak (PK) Quasi-peak (QP)
ENVIRONMENTAL CONDITIONS	25deg. C, 65%RH	TESTED BY	Gavin Wu

ANTENNA POLARITY & TEST DISTANCE: HORIZONTAL AT 3 M

FREQ. (MHz)	EMISSION LEVEL (dBuV/m)	READ LEVEL (dBuV)	LIMIT (dBuV/m)	MARGIN (dB)	ANTENNA FACTOR (dB/m)	CABLE LOSS (dB)	PREAMP FACTOR (dB)	ANTENNA HEIGHT (cm)	TABLE ANGLE (Degree)	REMARK
304.51	32.56	49.74	46	-13.44	13.06	1.65	31.89	137	150	Peak
399.57	30.36	45.25	46	-15.64	15.33	1.91	32.13	101	357	Peak
495.6	28.82	41.2	46	-17.18	17.23	2.08	31.69	101	4	Peak
597.45	29.33	39.76	46	-16.67	19.54	2.25	32.22	104	300	Peak
696.39	29.91	38.5	46	-16.09	20.77	2.45	31.81	139	229	Peak
786.6	31.58	38.36	46	-14.42	22.04	2.59	31.41	127	182	Peak

ANTENNA POLARITY & TEST DISTANCE: VERTICAL AT 3 M

FREQ. (MHz)	EMISSION LEVEL (dBuV/m)	READ LEVEL (dBuV)	LIMIT (dBuV/m)	MARGIN (dB)	ANTENNA FACTOR (dB/m)	CABLE LOSS (dB)	PREAMP FACTOR (dB)	ANTENNA HEIGHT (cm)	TABLE ANGLE (Degree)	REMARK
152.22	22.74	40.57	43.5	-20.76	12.71	1.12	31.66	116	19	Peak
216.24	22.4	42.65	46	-23.6	10.05	1.36	31.66	129	344	Peak
420.91	27.21	41.57	46	-18.79	15.75	1.94	32.05	103	202	Peak
586.78	31.72	42.31	46	-14.28	19.3	2.24	32.13	134	123	Peak
623.64	31.09	41.06	46	-14.91	19.89	2.3	32.16	124	127	Peak
652.74	30.2	39.6	46	-15.8	20.24	2.36	32	107	87	Peak

REMARKS: Emission Level = Read Level + Antenna Factor + Cable Loss - Preamp Factor

Margin value = Emission level – Limit value

MODE B
802.11ac (80MHz)

EUT TEST CONDITION		MEASUREMENT DETAIL	
CHANNEL	Channel 42	FREQUENCY RANGE	30MHz ~ 1GHz
INPUT POWER	120Vac, 60 Hz	DETECTOR FUNCTION	Peak (PK) Quasi-peak (QP)
ENVIRONMENTAL CONDITIONS	25deg. C, 65%RH	TESTED BY	Gavin Wu

ANTENNA POLARITY & TEST DISTANCE: HORIZONTAL AT 3 M										
FREQ. (MHz)	EMISSION LEVEL (dBuV/m)	READ LEVEL (dBuV)	LIMIT (dBuV/m)	MARGIN (dB)	ANTENNA FACTOR (dB/m)	CABLE LOSS (dB)	PREAMP FACTOR (dB)	ANTENNA HEIGHT (cm)	TABLE ANGLE (Degree)	REMARK
322.94	28.99	45.66	46	-17.01	13.5	1.7	31.87	138	342	Peak
477.17	34.45	47.39	46	-11.55	16.87	2.05	31.86	105	130	Peak
551.86	30.93	42.22	46	-15.07	18.5	2.18	31.97	131	80	Peak
600.36	32.83	43.21	46	-13.17	19.61	2.26	32.25	108	34	Peak
647.89	30.18	39.67	46	-15.82	20.19	2.35	32.03	101	0	Peak
696.39	30.67	39.26	46	-15.33	20.77	2.45	31.81	122	45	Peak
ANTENNA POLARITY & TEST DISTANCE: VERTICAL AT 3 M										
FREQ. (MHz)	EMISSION LEVEL (dBuV/m)	READ LEVEL (dBuV)	LIMIT (dBuV/m)	MARGIN (dB)	ANTENNA FACTOR (dB/m)	CABLE LOSS (dB)	PREAMP FACTOR (dB)	ANTENNA HEIGHT (cm)	TABLE ANGLE (Degree)	REMARK
344.28	26.51	42.58	46	-19.49	14.01	1.75	31.83	107	17	Peak
478.14	28.05	40.97	46	-17.95	16.89	2.05	31.86	128	87	Peak
489.78	28.98	41.56	46	-17.02	17.12	2.07	31.77	119	312	Peak
543.13	31.28	42.62	46	-14.72	18.3	2.16	31.8	120	314	Peak
608.12	31.77	41.9	46	-14.23	19.7	2.28	32.11	133	70	Peak
681.84	28.84	37.66	46	-17.16	20.6	2.42	31.84	101	200	Peak

REMARKS: Emission Level = Read Level + Antenna Factor + Cable Loss - Preamp Factor
Margin value = Emission level – Limit value



802.11ac (80MHz)

EUT TEST CONDITION		MEASUREMENT DETAIL	
CHANNEL	Channel 58	FREQUENCY RANGE	30MHz ~ 1GHz
INPUT POWER	120Vac, 60 Hz	DETECTOR FUNCTION	Peak (PK) Quasi-peak (QP)
ENVIRONMENTAL CONDITIONS	25deg. C, 65%RH	TESTED BY	Gavin Wu

ANTENNA POLARITY & TEST DISTANCE: HORIZONTAL AT 3 M

FREQ. (MHz)	EMISSION LEVEL (dBuV/m)	READ LEVEL (dBuV)	LIMIT (dBuV/m)	MARGIN (dB)	ANTENNA FACTOR (dB/m)	CABLE LOSS (dB)	PREAMP FACTOR (dB)	ANTENNA HEIGHT (cm)	TABLE ANGLE (Degree)	REMARK
435.46	30.36	44.36	46	-15.64	16.04	1.96	32	102	120	Peak
482.99	35.79	48.59	46	-10.21	16.98	2.05	31.83	108	44	Peak
492.69	35.93	48.4	46	-10.07	17.18	2.08	31.73	112	186	Peak
600.36	33.89	44.27	46	-12.11	19.61	2.26	32.25	134	8	Peak
647.89	31.45	40.94	46	-14.55	20.19	2.35	32.03	136	46	Peak
743.92	30.32	37.76	46	-15.68	21.44	2.53	31.41	115	153	Peak

ANTENNA POLARITY & TEST DISTANCE: VERTICAL AT 3 M

FREQ. (MHz)	EMISSION LEVEL (dBuV/m)	READ LEVEL (dBuV)	LIMIT (dBuV/m)	MARGIN (dB)	ANTENNA FACTOR (dB/m)	CABLE LOSS (dB)	PREAMP FACTOR (dB)	ANTENNA HEIGHT (cm)	TABLE ANGLE (Degree)	REMARK
227.88	21.93	41.81	46	-24.07	10.54	1.41	31.83	123	200	Peak
401.51	24.48	39.3	46	-21.52	15.37	1.91	32.1	119	55	Peak
470.38	27.41	40.54	46	-18.59	16.73	2.03	31.89	131	351	Peak
602.3	30.98	41.31	46	-15.02	19.63	2.26	32.22	120	15	Peak
651.77	29.52	38.94	46	-16.48	20.23	2.36	32.01	121	21	Peak
717.73	27.93	36.06	46	-18.07	21.07	2.48	31.68	119	337	Peak

REMARKS: Emission Level = Read Level + Antenna Factor + Cable Loss - Preamp Factor

Margin value = Emission level – Limit value



802.11a

EUT TEST CONDITION		MEASUREMENT DETAIL	
CHANNEL	Channel 140	FREQUENCY RANGE	30MHz ~ 1GHz
INPUT POWER	120Vac, 60 Hz	DETECTOR FUNCTION	Peak (PK) Quasi-peak (QP)
ENVIRONMENTAL CONDITIONS	25deg. C, 65%RH	TESTED BY	Gavin Wu

ANTENNA POLARITY & TEST DISTANCE: HORIZONTAL AT 3 M

FREQ. (MHz)	EMISSION LEVEL (dBuV/m)	READ LEVEL (dBuV)	LIMIT (dBuV/m)	MARGIN (dB)	ANTENNA FACTOR (dB/m)	CABLE LOSS (dB)	PREAMP FACTOR (dB)	ANTENNA HEIGHT (cm)	TABLE ANGLE (Degree)	REMARK
298.69	28.29	45.57	46	-17.71	12.91	1.63	31.82	106	233	Peak
399.57	29.71	44.6	46	-16.29	15.33	1.91	32.13	114	25	Peak
486.87	36.1	48.77	46	-9.9	17.06	2.06	31.79	139	198	Peak
551.86	31.88	43.17	46	-14.12	18.5	2.18	31.97	106	41	Peak
696.39	30.85	39.44	46	-15.15	20.77	2.45	31.81	103	10	Peak
743.92	31.06	38.5	46	-14.94	21.44	2.53	31.41	133	120	Peak

ANTENNA POLARITY & TEST DISTANCE: VERTICAL AT 3 M

FREQ. (MHz)	EMISSION LEVEL (dBuV/m)	READ LEVEL (dBuV)	LIMIT (dBuV/m)	MARGIN (dB)	ANTENNA FACTOR (dB/m)	CABLE LOSS (dB)	PREAMP FACTOR (dB)	ANTENNA HEIGHT (cm)	TABLE ANGLE (Degree)	REMARK
420.91	30.32	44.68	46	-15.68	15.75	1.94	32.05	136	108	Peak
432.55	24.76	38.83	46	-21.24	15.98	1.96	32.01	116	235	Peak
541.19	26.57	37.9	46	-19.43	18.26	2.16	31.75	120	256	Peak
580.96	24.62	35.35	46	-21.38	19.17	2.22	32.12	133	289	Peak
619.76	26.43	36.47	46	-19.57	19.84	2.29	32.17	113	116	Peak
757.5	25.78	33.02	46	-20.22	21.63	2.54	31.41	113	348	Peak

REMARKS: Emission Level = Read Level + Antenna Factor + Cable Loss - Preamp Factor

Margin value = Emission level – Limit value

802.11ac (80MHz)

EUT TEST CONDITION		MEASUREMENT DETAIL	
CHANNEL	Channel 155	FREQUENCY RANGE	30MHz ~ 1GHz
INPUT POWER	120Vac, 60 Hz	DETECTOR FUNCTION	Peak (PK) Quasi-peak (QP)
ENVIRONMENTAL CONDITIONS	25deg. C, 65%RH	TESTED BY	Gavin Wu

ANTENNA POLARITY & TEST DISTANCE: HORIZONTAL AT 3 M

FREQ. (MHz)	EMISSION LEVEL (dBuV/m)	READ LEVEL (dBuV)	LIMIT (dBuV/m)	MARGIN (dB)	ANTENNA FACTOR (dB/m)	CABLE LOSS (dB)	PREAMP FACTOR (dB)	ANTENNA HEIGHT (cm)	TABLE ANGLE (Degree)	REMARK
278.32	25.55	43.52	46	-20.45	12.31	1.58	31.86	124	260	Peak
398.6	31.4	46.31	46	-14.6	15.31	1.9	32.12	128	127	Peak
480.08	35.55	48.42	46	-10.45	16.93	2.05	31.85	132	229	Peak
600.36	33.04	43.42	46	-12.96	19.61	2.26	32.25	126	103	Peak
647.89	30.38	39.87	46	-15.62	20.19	2.35	32.03	136	355	Peak
696.39	31.15	39.74	46	-14.85	20.77	2.45	31.81	114	102	Peak

ANTENNA POLARITY & TEST DISTANCE: VERTICAL AT 3 M

FREQ. (MHz)	EMISSION LEVEL (dBuV/m)	READ LEVEL (dBuV)	LIMIT (dBuV/m)	MARGIN (dB)	ANTENNA FACTOR (dB/m)	CABLE LOSS (dB)	PREAMP FACTOR (dB)	ANTENNA HEIGHT (cm)	TABLE ANGLE (Degree)	REMARK
216.24	25.06	45.31	46	-20.94	10.05	1.36	31.66	108	325	Peak
344.28	26.09	42.16	46	-19.91	14.01	1.75	31.83	107	321	Peak
481.05	23.59	36.43	46	-22.41	16.95	2.05	31.84	106	201	Peak
531.49	29.76	41.28	46	-16.24	18.04	2.14	31.7	128	356	Peak
680.87	24.02	32.85	46	-21.98	20.59	2.42	31.84	137	107	Peak
758.47	25.39	32.62	46	-20.61	21.64	2.55	31.42	123	249	Peak

REMARKS: Emission Level = Read Level + Antenna Factor + Cable Loss - Preamp Factor

Margin value = Emission level – Limit value

4.2 Conducted Emission Measurement

4.2.1 Limits of Conducted Emission Measurement

Frequency (MHz)	Conducted Limit (dBuV)	
	Quasi-peak	Average
0.15 - 0.5	66 - 56	56 - 46
0.50 - 5.0	56	46
5.0 - 30.0	60	50

Note: 1. The lower limit shall apply at the transition frequencies.

2. The limit decreases in line with the logarithm of the frequency in the range of 0.15 to 0.50MHz.

4.2.2 Test Instruments

Description & Manufacturer	Model No.	Serial No.	Date Of Calibration	Due Date Of Calibration
Test Receiver ROHDE & SCHWARZ	ESCI	100613	Nov. 11, 2014	Nov. 10, 2015
RF signal cable (with 10dB PAD) Woken	5D-FB	Cable-cond1-01	Dec. 26, 2014	Dec. 25, 2015
LISN ROHDE & SCHWARZ (EUT)	ESH3-Z5	835239/001	Feb. 26, 2015	Feb. 25, 2016
LISN ROHDE & SCHWARZ (Peripheral)	ESH3-Z5	100311	Jul. 24, 2015	Jul. 23, 2016
Software ADT	BV ADT_Cond_ V7.3.7.3	NA	NA	NA

- Note:**
1. The calibration interval of the above test instruments is 12 months and the calibrations are traceable to NML/ROC and NIST/USA.
 2. The test was performed in HwaYa Shielded Room 1.
 3. The VCCI Site Registration No. is C-2040.

4.2.3 Test Procedures

- a. The EUT was placed 0.4 meters from the conducting wall of the shielded room with EUT being connected to the power mains through a line impedance stabilization network (LISN). Other support units were connected to the power mains through another LISN. The two LISNs provide 50 ohm/ 50uH of coupling impedance for the measuring instrument.
- b. Both lines of the power mains connected to the EUT were checked for maximum conducted interference.
- c. The frequency range from 150kHz to 30MHz was searched. Emission levels under (Limit - 20dB) was not recorded.

NOTE: All modes of operation were investigated and the worst-case emissions are reported.

4.2.4 Deviation from Test Standard

No deviation.

4.2.5 Test Setup

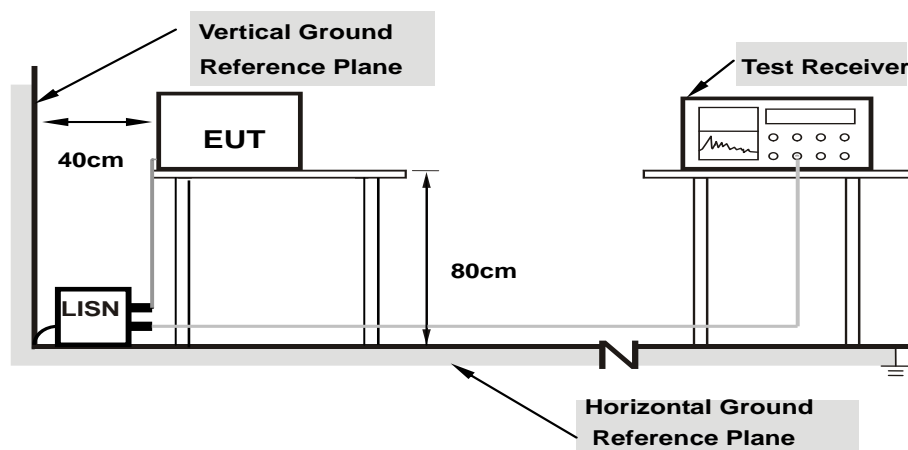

- Note:**
1. Support units were connected to second LISN.
 2. Both of LISNs (AMN) are 80 cm from EUT and at least 80 from other units and other metal planes

For the actual test configuration, please refer to the attached file (Test Setup Photo).

4.2.6 EUT Operating Conditions

Same as 4.1.6.

4.2.7 Test Results

MODE A

Frequency Range	150kHz ~ 30MHz	Detector Function & Resolution Bandwidth	Quasi-Peak (QP) / Average (AV), 9kHz
Input Power	120Vac, 60Hz	Environmental Conditions	25°C, 65%RH
Tested by	Toby Tian	Test Date	2015/9/18

Phase Of Power : Line (L)										
No	Frequency (MHz)	Correction Factor (dB)	Reading Value (dBuV)		Emission Level (dBuV)		Limit (dBuV)		Margin (dB)	
			Q.P.	AV.	Q.P.	AV.	Q.P.	AV.	Q.P.	AV.
1	0.15400	9.85	29.31	19.93	39.16	29.78	65.78	55.78	-26.62	-26.00
2	0.18600	9.90	43.75	25.14	53.65	35.04	64.21	54.21	-10.56	-19.17
3	0.26600	9.92	32.31	18.33	42.23	28.25	61.24	51.24	-19.01	-22.99
4	0.33800	9.91	26.74	11.96	36.65	21.87	59.25	49.25	-22.60	-27.38
5	1.60214	10.07	16.62	6.40	26.69	16.47	56.00	46.00	-29.31	-29.53
6	4.00200	10.19	13.25	4.76	23.44	14.95	56.00	46.00	-32.56	-31.05

Remarks:

1. Q.P. and AV. are abbreviations of quasi-peak and average individually.
2. The emission levels of other frequencies were very low against the limit.
3. Margin value = Emission level – Limit value
4. Correction factor = Insertion loss + Cable loss
5. Emission Level = Correction Factor + Reading Value

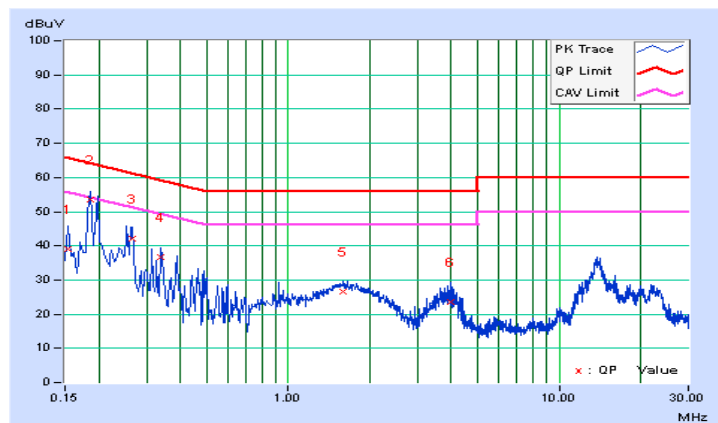

Frequency Range	150kHz ~ 30MHz	Detector Function & Resolution Bandwidth	Quasi-Peak (QP) / Average (AV), 9kHz
Input Power	120Vac, 60Hz	Environmental Conditions	25°C, 65%RH
Tested by	Toby Tian	Test Date	2015/9/18

Phase Of Power : Neutral (N)										
No	Frequency (MHz)	Correction Factor (dB)	Reading Value (dBuV)		Emission Level (dBuV)		Limit (dBuV)		Margin (dB)	
			Q.P.	AV.	Q.P.	AV.	Q.P.	AV.	Q.P.	AV.
1	0.16600	9.93	43.38	20.71	53.31	30.64	65.16	55.16	-11.84	-24.51
2	0.17400	9.96	42.84	27.11	52.80	37.07	64.77	54.77	-11.97	-17.70
3	0.23911	10.02	35.36	24.03	45.38	34.05	62.13	52.13	-16.74	-18.07
4	0.30792	10.01	23.56	11.02	33.57	21.03	60.03	50.03	-26.46	-29.00
5	0.38200	9.99	20.79	6.58	30.78	16.57	58.24	48.24	-27.45	-31.66
6	3.53400	10.27	8.78	2.03	19.05	12.30	56.00	46.00	-36.95	-33.70

Remarks:

1. Q.P. and AV. are abbreviations of quasi-peak and average individually.
2. The emission levels of other frequencies were very low against the limit.
3. Margin value = Emission level – Limit value
4. Correction factor = Insertion loss + Cable loss
5. Emission Level = Correction Factor + Reading Value

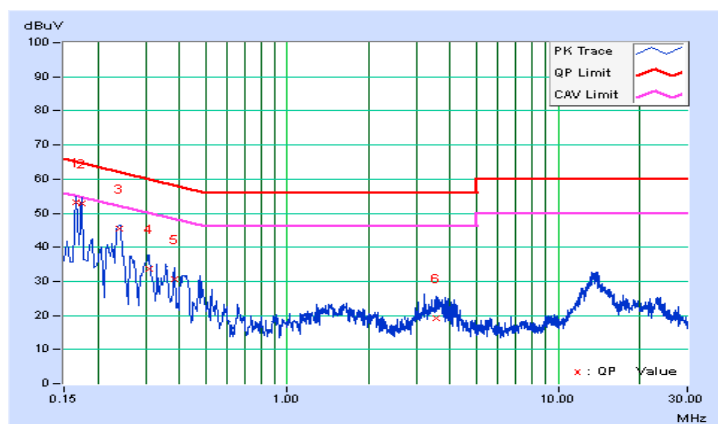

MODE B

Frequency Range	150kHz ~ 30MHz	Detector Function & Resolution Bandwidth	Quasi-Peak (QP) / Average (AV), 9kHz
Input Power	120Vac, 60Hz	Environmental Conditions	25°C, 65%RH
Tested by	Toby Tian	Test Date	2015/9/18

Phase Of Power : Line (L)										
No	Frequency (MHz)	Correction Factor (dB)	Reading Value (dBuV)		Emission Level (dBuV)		Limit (dBuV)		Margin (dB)	
			Q.P.	AV.	Q.P.	AV.	Q.P.	AV.	Q.P.	AV.
1	0.15000	9.84	28.62	19.66	38.46	29.50	66.00	56.00	-27.54	-26.50
2	0.18600	9.90	44.29	31.39	54.19	41.29	64.21	54.21	-10.02	-12.92
3	0.25800	9.92	28.33	12.23	38.25	22.15	61.50	51.50	-23.24	-29.34
4	0.37800	9.90	23.84	9.71	33.74	19.61	58.32	48.32	-24.58	-28.71
5	1.67000	10.08	14.55	6.52	24.63	16.60	56.00	46.00	-31.37	-29.40
6	3.82192	10.18	9.64	2.54	19.82	12.72	56.00	46.00	-36.18	-33.28

Remarks:

1. Q.P. and AV. are abbreviations of quasi-peak and average individually.
2. The emission levels of other frequencies were very low against the limit.
3. Margin value = Emission level – Limit value
4. Correction factor = Insertion loss + Cable loss
5. Emission Level = Correction Factor + Reading Value

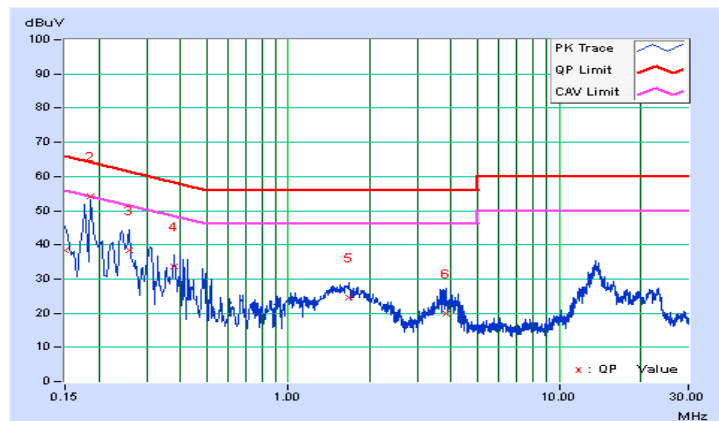

Frequency Range	150kHz ~ 30MHz	Detector Function & Resolution Bandwidth	Quasi-Peak (QP) / Average (AV), 9kHz
Input Power	120Vac, 60Hz	Environmental Conditions	25°C, 65%RH
Tested by	Toby Tian	Test Date	2015/9/25

Phase Of Power : Neutral (N)										
No	Frequency (MHz)	Correction Factor (dB)	Reading Value (dBuV)		Emission Level (dBuV)		Limit (dBuV)		Margin (dB)	
			Q.P.	AV.	Q.P.	AV.	Q.P.	AV.	Q.P.	AV.
1	0.15000	9.89	32.26	19.97	42.15	29.86	66.00	56.00	-23.85	-26.14
2	0.18519	9.99	43.95	24.02	53.94	34.01	64.25	54.25	-10.31	-20.24
3	0.21282	10.03	34.99	15.98	45.02	26.01	63.09	53.09	-18.08	-27.09
4	0.25557	10.02	33.40	18.96	43.42	28.98	61.57	51.57	-18.16	-22.60
5	0.34159	10.00	26.82	10.73	36.82	20.73	59.16	49.16	-22.34	-28.43
6	0.36896	10.00	24.02	6.97	34.02	16.97	58.52	48.52	-24.51	-31.56

Remarks:

1. Q.P. and AV. are abbreviations of quasi-peak and average individually.
2. The emission levels of other frequencies were very low against the limit.
3. Margin value = Emission level – Limit value
4. Correction factor = Insertion loss + Cable loss
5. Emission Level = Correction Factor + Reading Value

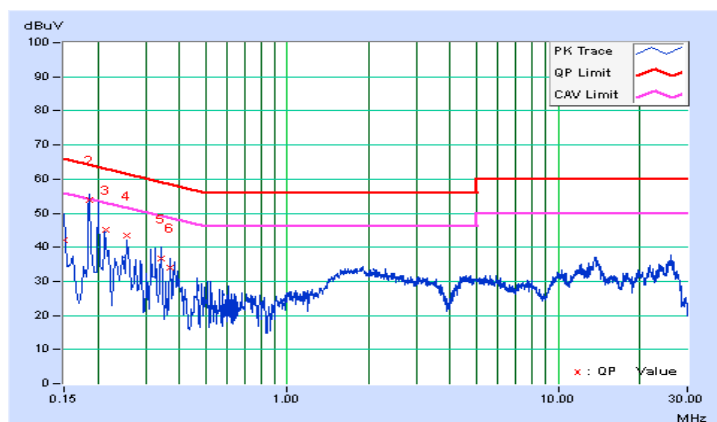

4.3 Transmit Power Measurement

4.3.1 Limits of Transmit Power Measurement

Operation Band	EUT Category		LIMIT
U-NII-1		Outdoor Access Point	1 Watt (30 dBm) (Max. e.i.r.p \leq 125mW(21 dBm) at any elevation angle above 30 degrees as measured from the horizon)
		Fixed point-to-point Access Point	1 Watt (30 dBm)
		Indoor Access Point	1 Watt (30 dBm)
	√	Mobile and Portable client device	250mW (24 dBm)
U-NII-2A		√	250mW (24 dBm) or 11 dBm+10 log B*
U-NII-2C		√	250mW (24 dBm) or 11 dBm+10 log B*
U-NII-3		√	1 Watt (30 dBm)

*B is the 26 dB emission bandwidth in megahertz

Per KDB 662911 Method of conducted output power measurement on IEEE 802.11 devices,

Array Gain = 0 dB (i.e., no array gain) for $N_{ANT} \leq 4$;

Array Gain = 0 dB (i.e., no array gain) for channel widths ≥ 40 MHz for any N_{ANT} ;

Array Gain = $5 \log(N_{ANT}/N_{SS})$ dB or 3 dB, whichever is less for 20-MHz channel widths with $N_{ANT} \geq 5$.

For power measurements on all other devices: Array Gain = $10 \log(N_{ANT}/N_{SS})$ dB.

4.3.2 Test Setup

FOR POWER OUTPUT MEASUREMENT

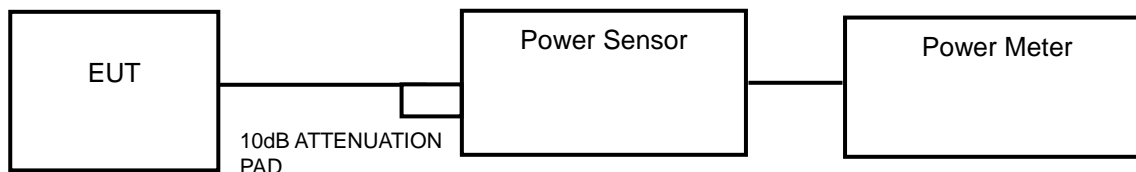

or

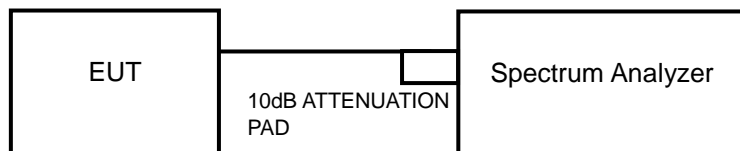

FOR 26dB BANDWIDTH

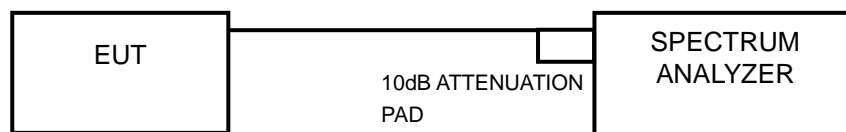

4.3.3 Test Instruments

Refer to section 4.1.2 to get information of above instrument.

4.3.4 Test Procedure

FOR AVERAGE POWER MEASUREMENT

<802.11a, 802.11n (20MHz), 802.11n (40MHz)>

Method PM is used to perform output power measurement, trigger and gating function of wide band power meter is enabled to measure max output power of TX on burst. Duty factor is not added to measured value.

<802.11ac (80MHz)>

Method SA-1 is used to perform output power measurement, trigger and gating function of spectrum analyzer is enabled to measure max output power of TX on burst. Duty factor is not added to measured value.

FOR 26dB BANDWIDTH

- 1) Set RBW = approximately 1% of the emission bandwidth.
- 2) Set the VBW > RBW.
- 3) Detector = Peak.
- 4) Trace mode = max hold.
- 5) Measure the maximum width of the emission that is 26 dB down from the peak of the emission. Compare this with the RBW setting of the analyzer. Readjust RBW and repeat measurement as needed until the RBW/EBW ratio is approximately 1%.

4.3.5 Deviation from Test Standard

No deviation.

4.3.6 EUT Operating Conditions

The software provided by client to enable the EUT under transmission condition continuously at lowest, middle and highest channel frequencies individually.

4.3.7 Test Result

POWER OUTPUT:

802.11a

Channel	Frequency (MHz)	Maximum Conducted Power (mW)	Maximum Conducted Power (dBm)	Power Limit (dBm)	Pass / Fail
36	5180	31.99	15.05	24	Pass
44	5220	32.06	15.06	24	Pass
48	5240	31.92	15.04	24	Pass
52	5260	31.70	15.01	24	Pass
60	5300	31.12	14.93	24	Pass
64	5320	31.92	15.04	24	Pass
100	5500	31.05	14.92	24	Pass
116	5580	31.84	15.03	24	Pass
140	5700	31.70	15.01	24	Pass
149	5745	31.99	15.05	30	Pass
157	5785	32.28	15.09	30	Pass
165	5825	32.06	15.06	30	Pass

NOTE:

For U-NII-2A, U-NII-2C Band:

1. $11\text{dBm} + 10\log(22.57) = 24.54\text{ dBm} > 24\text{dBm}$.
2. $11\text{dBm} + 10\log(22.89) = 24.60\text{ dBm} > 24\text{dBm}$.
3. $11\text{dBm} + 10\log(23.14) = 24.64\text{ dBm} > 24\text{dBm}$.
4. $11\text{dBm} + 10\log(22.69) = 24.56\text{ dBm} > 24\text{dBm}$.
5. $11\text{dBm} + 10\log(22.84) = 24.59\text{ dBm} > 24\text{dBm}$.
6. $11\text{dBm} + 10\log(22.66) = 24.55\text{ dBm} > 24\text{dBm}$.

802.11n (20MHz)

Channel	Frequency (MHz)	Maximum Conducted Power (mW)	Maximum Conducted Power (dBm)	Power Limit (dBm)	Pass / Fail
36	5180	31.70	15.01	24	Pass
44	5220	31.62	15.00	24	Pass
48	5240	31.77	15.02	24	Pass
52	5260	31.48	14.98	24	Pass
60	5300	31.19	14.94	24	Pass
64	5320	31.84	15.03	24	Pass
100	5500	31.19	14.94	24	Pass
116	5580	31.26	14.95	24	Pass
140	5700	31.55	14.99	24	Pass
149	5745	31.77	15.02	30	Pass
157	5785	31.92	15.04	30	Pass
165	5825	31.77	15.02	30	Pass

NOTE:
For U-NII-2A, U-NII-2C Band:

1. $11\text{dBm} + 10\log(22.91) = 24.60\text{ dBm} > 24\text{dBm}$.
2. $11\text{dBm} + 10\log(22.90) = 24.60\text{ dBm} > 24\text{dBm}$.
3. $11\text{dBm} + 10\log(22.97) = 24.61\text{ dBm} > 24\text{dBm}$.
4. $11\text{dBm} + 10\log(23.15) = 24.65\text{ dBm} > 24\text{dBm}$.
5. $11\text{dBm} + 10\log(23.59) = 24.73\text{ dBm} > 24\text{dBm}$.
6. $11\text{dBm} + 10\log(23.83) = 24.77\text{ dBm} > 24\text{dBm}$.

802.11n (40MHz)

Channel	Frequency (MHz)	Maximum Conducted Power (mW)	Maximum Conducted Power (dBm)	Power Limit (dBm)	Pass / Fail
38	5190	31.55	14.99	24	Pass
46	5230	31.84	15.03	24	Pass
54	5270	31.92	15.04	24	Pass
62	5310	31.62	15.00	24	Pass
102	5510	32.14	15.07	24	Pass
110	5550	31.33	14.96	24	Pass
134	5670	32.28	15.09	24	Pass
151	5755	32.14	15.07	30	Pass
159	5795	31.48	14.98	30	Pass

NOTE:
For U-NII-2A, U-NII-2C Band:

1. $11\text{dBm} + 10\log(46.74) = 27.70\text{ dBm} > 24\text{dBm}$.
2. $11\text{dBm} + 10\log(46.45) = 27.67\text{ dBm} > 24\text{dBm}$.
3. $11\text{dBm} + 10\log(47.22) = 27.74\text{ dBm} > 24\text{dBm}$.
4. $11\text{dBm} + 10\log(46.17) = 27.64\text{ dBm} > 24\text{dBm}$.
5. $11\text{dBm} + 10\log(46.91) = 27.71\text{ dBm} > 24\text{dBm}$.

802.11ac (80MHz)

Channel	Frequency (MHz)	Maximum Conducted Power (mW)	Maximum Conducted Power (dBm)	Power Limit (dBm)	Pass / Fail
42	5210	32.06	15.06	24	Pass
58	5290	32.14	15.07	24	Pass
106	5530	31.33	14.96	24	Pass
122	5610	31.62	15.00	24	Pass
155	5775	31.77	15.02	30	Pass

NOTE:
For U-NII-2A, U-NII-2C Band:

1. $11\text{dBm} + 10\log(85.13) = 30.30\text{ dBm} > 24\text{dBm}$.
2. $11\text{dBm} + 10\log(85.20) = 30.30\text{ dBm} > 24\text{dBm}$.
3. $11\text{dBm} + 10\log(84.36) = 30.26\text{ dBm} > 24\text{dBm}$.

26dB BANDWIDTH:
802.11a

Channel	Frequency (MHz)	26dBc Bandwidth (MHz)	Pass / Fail
36	5180	22.77	Pass
44	5220	22.71	Pass
48	5240	22.60	Pass
52	5260	22.57	Pass
60	5300	22.89	Pass
64	5320	23.14	Pass
100	5500	22.69	Pass
116	5580	22.84	Pass
140	5700	22.66	Pass

802.11n (20MHz)

Channel	Frequency (MHz)	26dBc Bandwidth (MHz)	Pass / Fail
36	5180	23.12	Pass
44	5220	23.26	Pass
48	5240	22.97	Pass
52	5260	22.91	Pass
60	5300	22.90	Pass
64	5320	22.97	Pass
100	5500	23.15	Pass
116	5580	23.59	Pass
140	5700	22.83	Pass

802.11n (40MHz)

Channel	Frequency (MHz)	26dBc Bandwidth (MHz)	Pass / Fail
38	5190	45.49	Pass
46	5230	45.96	Pass
54	5270	46.74	Pass
62	5310	46.45	Pass
102	5510	47.22	Pass
110	5550	46.17	Pass
134	5670	46.91	Pass

802.11ac (80MHz)

Channel	Frequency (MHz)	26dBc Bandwidth (MHz)	Pass / Fail
42	5210	85.16	Pass
58	5290	85.13	Pass
106	5530	85.20	Pass
122	5610	84.36	Pass

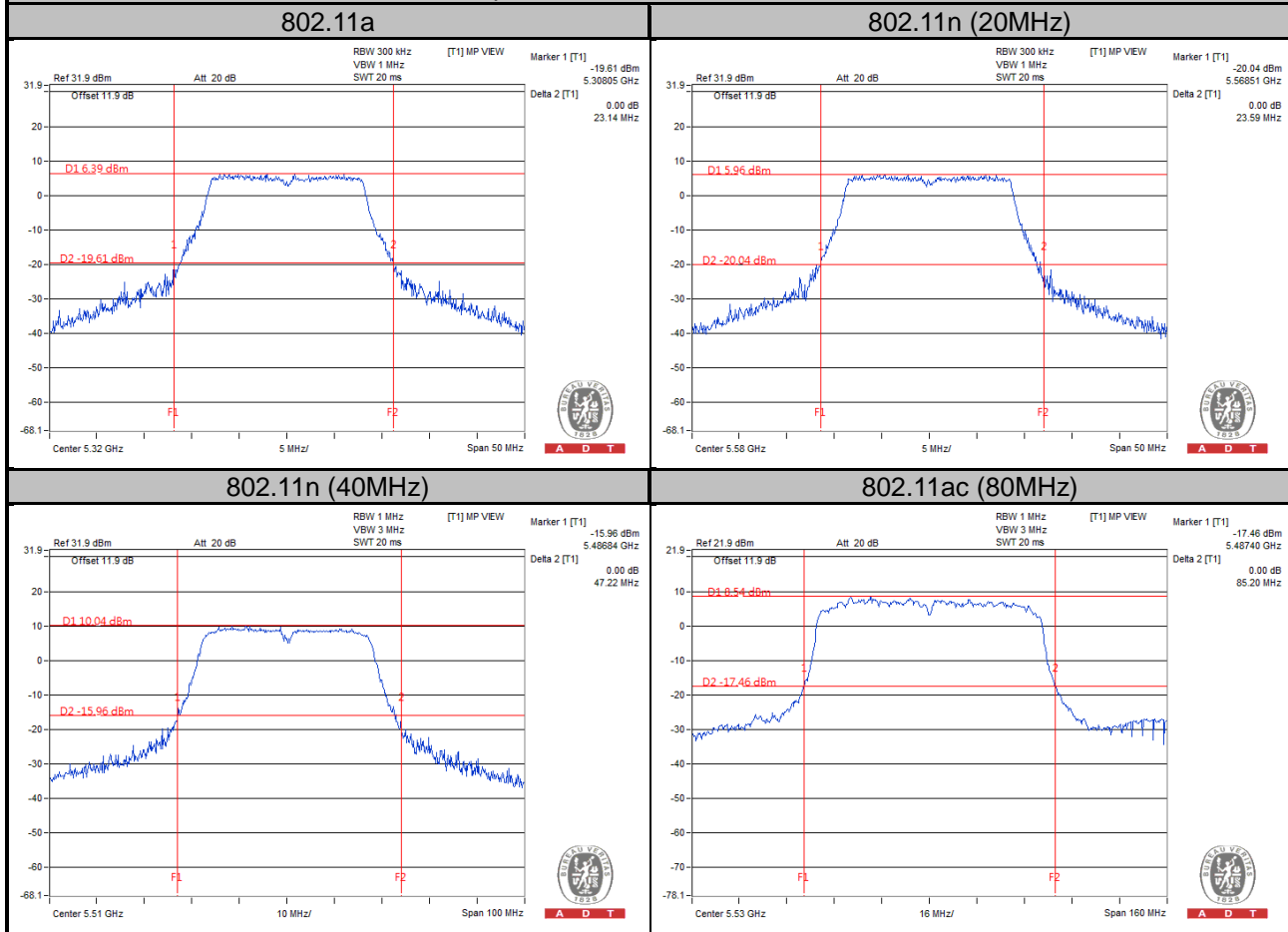
Spectrum Plot of Worst Value

4.4 Peak Power Spectral Density Measurement

4.4.1 Limits of Peak Power Spectral Density Measurement

Operation Band	EUT Category		Limit
U-NII-1		Outdoor Access Point	17dBm/ MHz
		Fixed point-to-point Access Point	
		Indoor Access Point	
	√	Mobile and Portable client device	11dBm/ MHz
U-NII-2A	√		11dBm/ MHz
U-NII-2C	√		11dBm/ MHz
U-NII-3	√		30dBm/ 500MHz

4.4.2 Test Setup

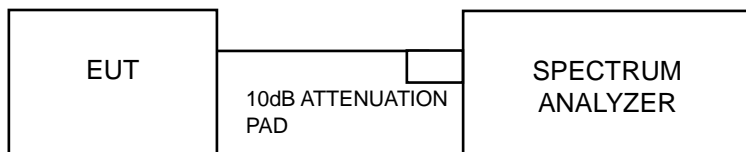

4.4.3 Test Instruments

Refer to section 4.1.3 to get information of above instrument.

4.4.4 Test Procedures

For U-NII-1, U-NII-2A, U-NII-2C band:

Using method SA-2

1. Set span to encompass the entire emission bandwidth (EBW) of the signal.
2. Set RBW = 1 MHz, Set VBW \geq 3 MHz, Detector = RMS
3. Sweep time = auto, trigger set to "free run".
4. Trace average at least 100 traces in power averaging mode.
5. Record the max value and add 10 log (1/duty cycle)

※For U-NII-3:

1. Set span to encompass the entire emission bandwidth (EBW) of the signal.
2. Set RBW = 300 kHz, Set VBW \geq 1 MHz, Detector = RMS
3. Use the peak marker function to determine the maximum power level in any 300 kHz band segment within the fundamental EBW.
4. Scale the observed power level to an equivalent value in 500 kHz by adjusting (reducing) the measured power by a bandwidth correction factor (BWCF) where $BWCF = 10\log(500 \text{ kHz}/300\text{kHz})$
5. Sweep time = auto, trigger set to "free run".
6. Trace average at least 100 traces in power averaging mode.
7. Record the max value and add 10 log (1/duty cycle)

4.4.5 Deviation from Test Standard

No deviation.

4.4.6 EUT Operating Conditions

Same as Item 4.3.6.

4.4.7 Test Results

802.11a

Channel	Frequency (MHz)	PSD w/o Duty Factor (dBm)	Duty Factor	PSD with Duty Factor (dBm)	Maximum Limit (dBm)	Pass / Fail
36	5180	1.65	0.76	2.41	11	Pass
44	5220	1.73	0.76	2.49	11	Pass
48	5240	1.87	0.76	2.63	11	Pass
52	5260	1.69	0.76	2.45	11	Pass
60	5300	1.88	0.76	2.64	11	Pass
64	5320	1.97	0.76	2.73	11	Pass
100	5500	2.23	0.76	2.99	11	Pass
116	5580	1.74	0.76	2.50	11	Pass
140	5700	1.53	0.76	2.29	11	Pass

NOTE: Refer to section 3.3 for duty cycle spectrum plot.

802.11n (20MHz)

Channel	Frequency (MHz)	PSD w/o Duty Factor (dBm)	Duty Factor	PSD with Duty Factor (dBm)	Maximum Limit (dBm)	Pass / Fail
36	5180	1.01	0.78	1.79	11	Pass
44	5220	1.19	0.78	1.97	11	Pass
48	5240	1.23	0.78	2.01	11	Pass
52	5260	1.11	0.78	1.89	11	Pass
60	5300	1.60	0.78	2.38	11	Pass
64	5320	1.58	0.78	2.36	11	Pass
100	5500	1.98	0.78	2.76	11	Pass
116	5580	1.69	0.78	2.47	11	Pass
140	5700	1.60	0.78	2.38	11	Pass

NOTE: Refer to section 3.3 for duty cycle spectrum plot.

802.11n (40MHz)

Channel	Frequency (MHz)	PSD w/o Duty Factor (dBm)	Duty Factor	PSD with Duty Factor (dBm)	Maximum Limit (dBm)	Pass / Fail
38	5190	-0.10	1.49	1.39	11	Pass
46	5230	-0.86	1.49	0.63	11	Pass
54	5270	-0.74	1.49	0.75	11	Pass
62	5310	-0.42	1.49	1.07	11	Pass
102	5510	-0.22	1.49	1.27	11	Pass
110	5550	-0.21	1.49	1.28	11	Pass
134	5670	-0.13	1.49	1.36	11	Pass

NOTE: Refer to section 3.3 for duty cycle spectrum plot.

802.11ac (80MHz)

Channel	Frequency (MHz)	PSD w/o Duty Factor (dBm)	Duty Factor	PSD with Duty Factor (dBm)	Maximum Limit (dBm)	Pass / Fail
42	5210	-6.70	2.57	-4.13	11	Pass
58	5290	-6.44	2.57	-3.87	11	Pass
106	5530	-6.10	2.57	-3.53	11	Pass
122	5610	-6.83	2.57	-4.26	11	Pass

NOTE: Refer to section 3.3 for duty cycle spectrum plot.

Spectrum Plot of Worst Value

802.11a

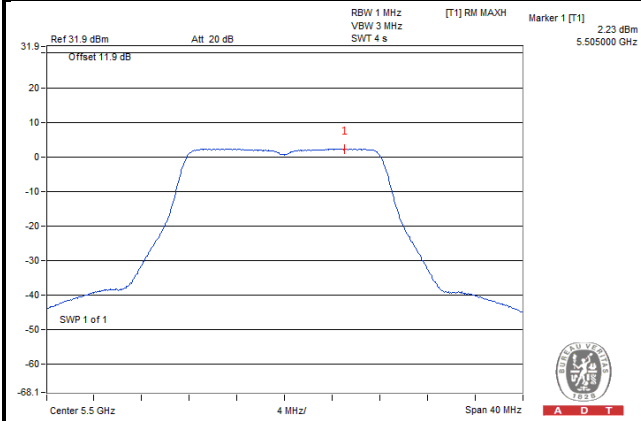

802.11n (20MHz)

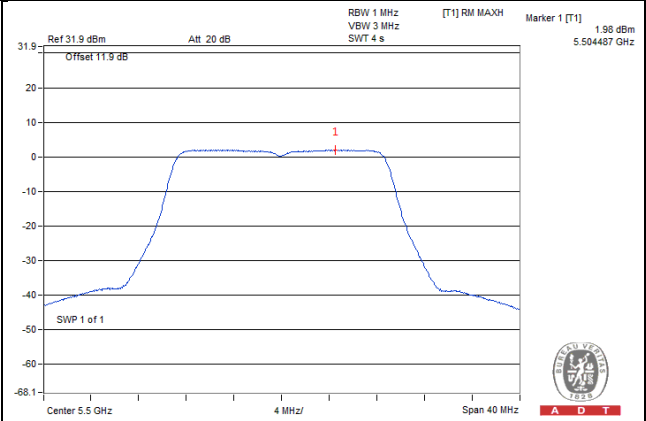

802.11n (40MHz)

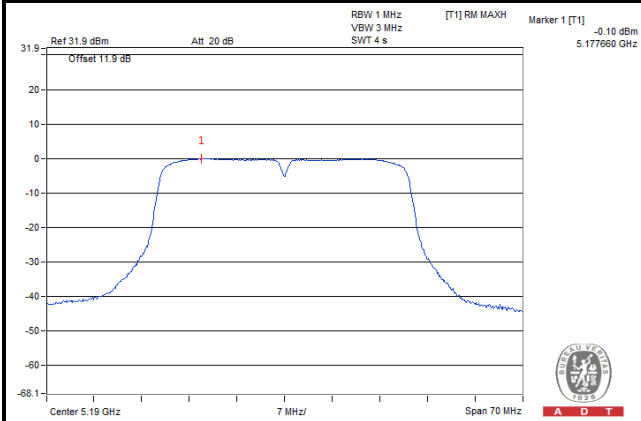

802.11ac (80MHz)

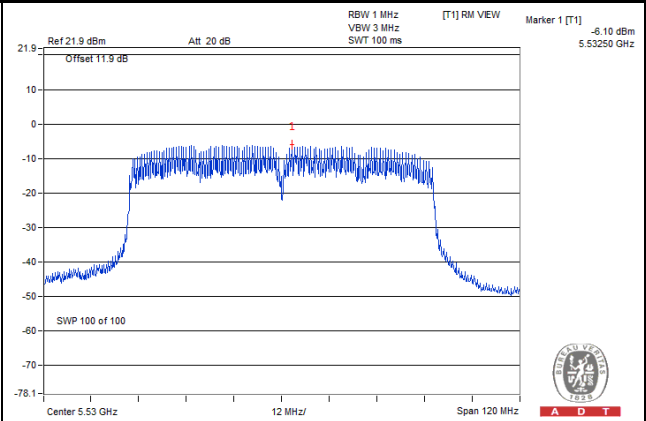

For U-NII-3 Band

802.11a

Channel	Frequency (MHz)	PSD w/o Duty Factor (dBm)	Duty Factor	PSD with Duty Factor (dBm)	Limit (dBm/500kHz)	Pass / Fail
149	5745	-0.29	0.76	0.47	30	Pass
157	5785	-0.25	0.76	0.51	30	Pass
165	5825	-0.20	0.76	0.56	30	Pass

NOTE: Refer to section 3.3 for duty cycle spectrum plot.

802.11n (20MHz)

Channel	Frequency (MHz)	PSD w/o Duty Factor (dBm)	Duty Factor	PSD with Duty Factor (dBm)	Limit (dBm/500kHz)	Pass / Fail
149	5745	-0.62	0.78	0.16	30	Pass
157	5785	-0.68	0.78	0.10	30	Pass
165	5825	-0.17	0.78	0.61	30	Pass

NOTE: Refer to section 3.3 for duty cycle spectrum plot.

802.11n (40MHz)

Channel	Frequency (MHz)	PSD w/o Duty Factor (dBm)	Duty Factor	PSD with Duty Factor (dBm)	Limit (dBm/500kHz)	Pass / Fail
151	5755	-3.23	1.49	-1.74	30	Pass
159	5795	-2.98	1.49	-1.49	30	Pass

NOTE: Refer to section 3.3 for duty cycle spectrum plot.

802.11ac (80MHz)

Channel	Frequency (MHz)	PSD w/o Duty Factor (dBm)	Duty Factor	PSD with Duty Factor (dBm)	Limit (dBm/500kHz)	Pass / Fail
155	5775	-4.99	2.57	-2.42	30	Pass

NOTE: Refer to section 3.3 for duty cycle spectrum plot.

Spectrum Plot of Worst Value

802.11a

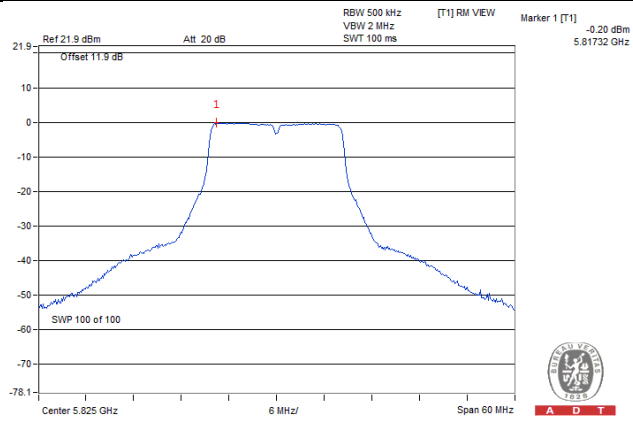

802.11n (20MHz)

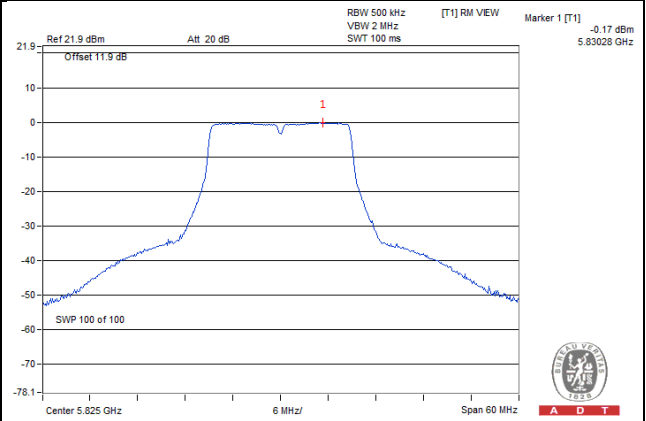

802.11n (40MHz)

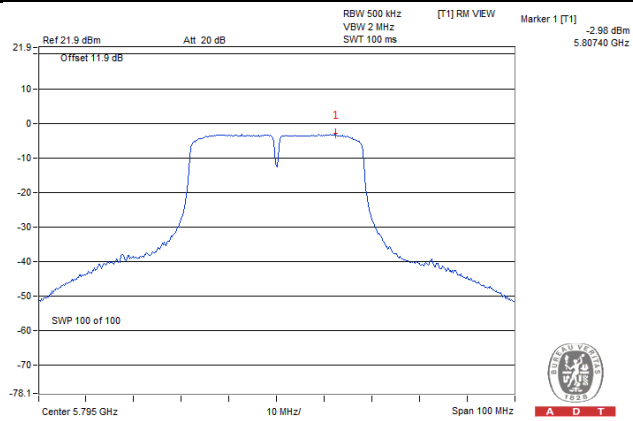

802.11ac (80MHz)

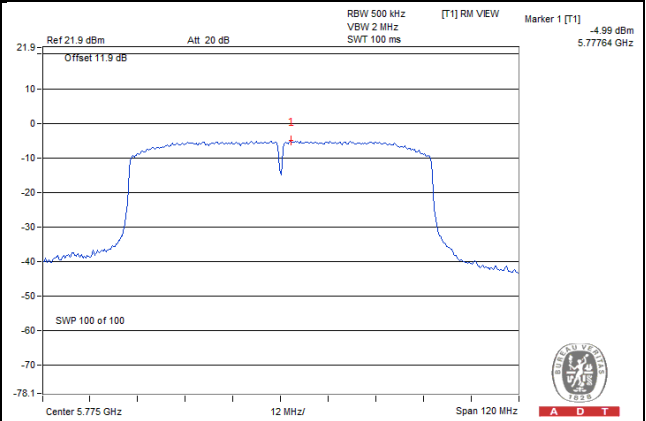

4.5 Frequency Stability

4.5.1 Limit of Frequency Stability Measurement

The frequency of the carrier signal shall be maintained within band of operation

4.5.2 Test Setup

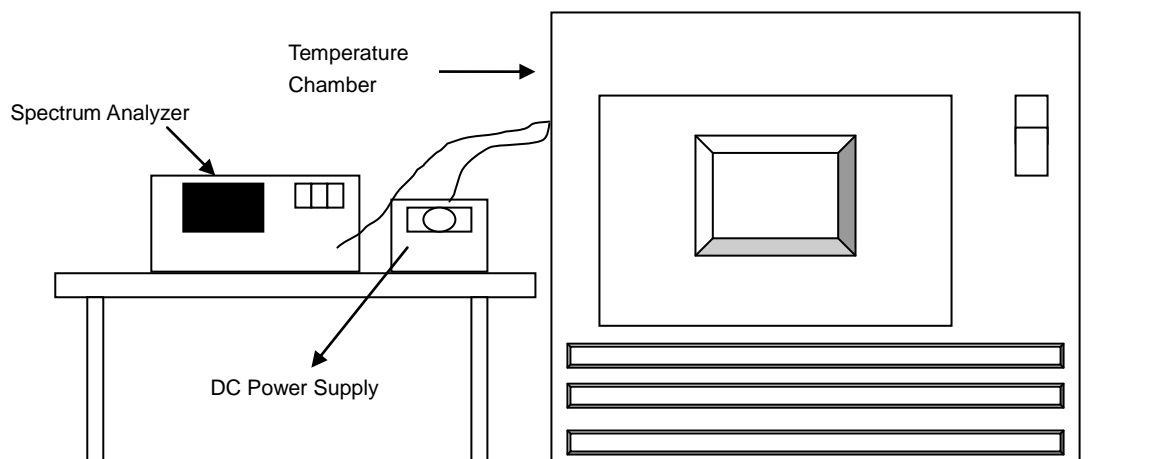

4.5.3 Test Instruments

Refer to section 4.1.3 to get information of above instrument.

4.5.4 Test Procedure

- To ensure emission at the band edge is maintained within the authorized band, those values shall be measured by radiation emissions at upper and lower frequency points, and finally compensated by frequency deviation as procedures below.
- The EUT was operated at the maximum output power, and connected to the spectrum analyzer, which is set to maximum hold function and peak detector. The peak value of the power envelope was measured and noted. The upper and lower frequency points were respectively measured relatively 10dB lower than the measured peak value.
- The frequency deviation was calculated by adding the upper frequency point and the lower frequency point divided by two. Those detailed values of frequency deviation are provided in table below.

4.5.5 Deviation from Test Standard

No deviation.

4.5.6 EUT Operating Condition

Set the EUT transmit at un-modulation mode to test frequency stability.

4.5.7 Test Results

Frequency Stability Versus Temp.									
Operating Frequency: 5320MHz									
Temp. (°C)	Power Supply (Vdc)	0 Minute		2 Minute		5 Minute		10 Minute	
		Measured Frequency (MHz)	Frequency Drift (ppm)	Measured Frequency (MHz)	Frequency Drift (ppm)	Measured Frequency (MHz)	Frequency Drift (ppm)	Measured Frequency (MHz)	Frequency Drift (ppm)
50	3.80	5320.016335	3.070	5320.016163	3.038	5320.016187	3.043	5320.016565	3.114
40	3.80	5320.016150	3.036	5320.016058	3.018	5320.016658	3.131	5320.016494	3.100
30	3.80	5320.017162	3.226	5320.017077	3.210	5320.017030	3.201	5320.016664	3.132
20	3.80	5320.016426	3.088	5320.016430	3.088	5320.016477	3.097	5320.016210	3.047
10	3.80	5320.019460	3.658	5320.019573	3.679	5320.019603	3.685	5320.019739	3.710
0	3.80	5320.018401	3.459	5320.018316	3.443	5320.018261	3.433	5320.018749	3.524
-10	3.80	5320.016316	3.067	5320.017002	3.196	5320.016512	3.104	5320.016671	3.134
-20	3.80	5320.016351	3.073	5320.016425	3.087	5320.016600	3.120	5320.016531	3.107
-30	3.80	5320.015287	2.873	5320.015600	2.932	5320.015032	2.826	5320.015674	2.946

Frequency Stability Versus Temp.									
Operating Frequency: 5320MHz									
Temp. (°C)	Power Supply (Vdc)	0 Minute		2 Minute		5 Minute		10 Minute	
		Measured Frequency (MHz)	Frequency Drift (ppm)	Measured Frequency (MHz)	Frequency Drift (ppm)	Measured Frequency (MHz)	Frequency Drift (ppm)	Measured Frequency (MHz)	Frequency Drift (ppm)
20	3.3	5320.016160	3.038	5320.016094	3.025	5320.015790	2.968	5320.016053	3.017
	3.80	5320.016426	3.088	5320.016430	3.088	5320.016477	3.097	5320.016210	3.047
	4.35	5320.017289	3.250	5320.016924	3.181	5320.017327	3.257	5320.017456	3.281

4.6 6dB Bandwidth Measurement

4.6.1 Limits of 6dB Bandwidth Measurement

The minimum of 6dB Bandwidth Measurement is 0.5MHz.

4.6.2 Test Setup

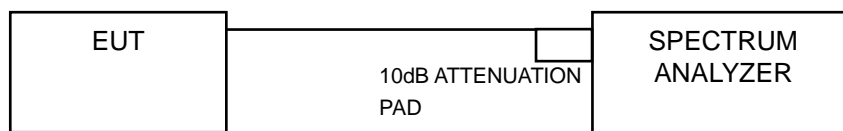

4.6.3 Test Instruments

Refer to section 4.1.3 to get information of above instrument.

4.6.4 Test Procedure

MEASUREMENT PROCEDURE REF

- Set resolution bandwidth (RBW) = 100kHz
- Set the video bandwidth (VBW) $\geq 3 \times$ RBW, Detector = Peak.
- Trace mode = max hold.
- Sweep = auto couple.
- Measure the maximum width of the emission that is constrained by the frequencies associated with the two amplitude points (upper and lower) that are attenuated by 6 dB relative to the maximum level measured in the fundamental emission

4.6.5 Deviation from Test Standard

No deviation.

4.6.6 EUT Operating Condition

The software provided by client to enable the EUT under transmission condition continuously at lowest, middle and highest channel frequencies individually.

4.6.7 Test Results

802.11a

Channel	Frequency (MHz)	6dB Bandwidth (MHz)	Minimum Limit (MHz)	Pass / Fail
149	5745	16.43	0.5	Pass
157	5785	16.41	0.5	Pass
165	5825	16.42	0.5	Pass

802.11n (20MHz)

Channel	Frequency (MHz)	6dB Bandwidth (MHz)	Minimum Limit (MHz)	Pass / Fail
149	5745	17.63	0.5	Pass
157	5785	17.64	0.5	Pass
165	5825	17.66	0.5	Pass

802.11n (40MHz)

Channel	Frequency (MHz)	6dB Bandwidth (MHz)	Minimum Limit (MHz)	Pass / Fail
151	5755	35.42	0.5	Pass
159	5795	35.24	0.5	Pass

802.11ac (80MHz)

Channel	Frequency (MHz)	6dB Bandwidth (MHz)	Minimum Limit (MHz)	Pass / Fail
155	5775	75.28	0.5	Pass

Spectrum Plot of Worst Value

802.11a

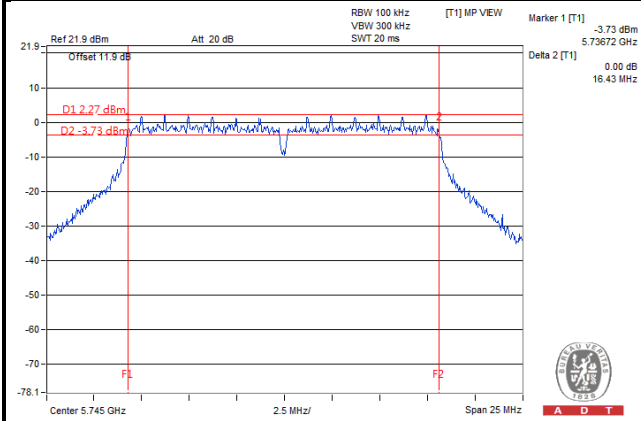

802.11n (20MHz)

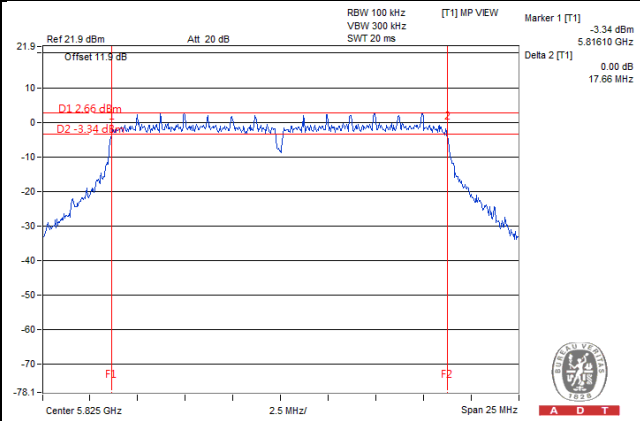

802.11n (40MHz)

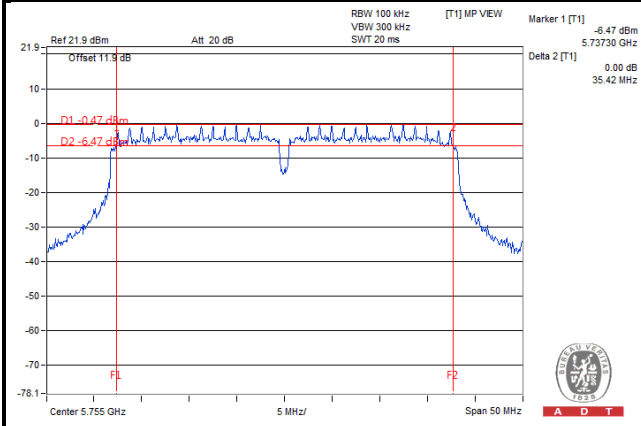

802.11ac (80MHz)

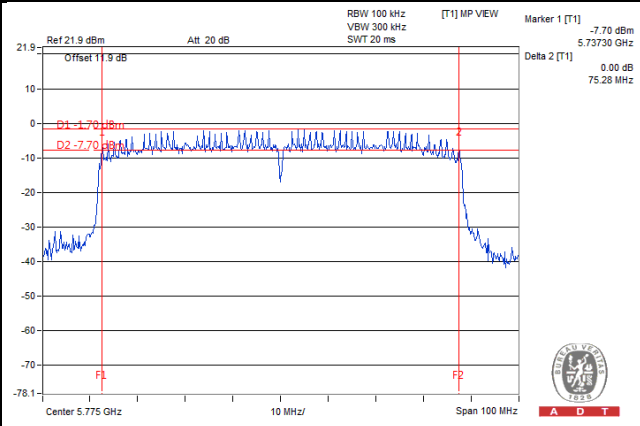



5 Pictures of Test Arrangements

Please refer to the attached file (Test Setup Photo).

Appendix – Information on the Testing Laboratories

We, Bureau Veritas Consumer Products Services (H.K.) Ltd., Taoyuan Branch, were founded in 1988 to provide our best service in EMC, Radio, Telecom and Safety consultation. Our laboratories are accredited and approved according to ISO/IEC 17025.

If you have any comments, please feel free to contact us at the following:

Linko EMC/RF Lab

Tel: 886-2-26052180

Fax: 886-2-26051924

Hsin Chu EMC/RF Lab/Telecom Lab

Tel: 886-3-5935343

Fax: 886-3-5935342

Hwa Ya EMC/RF/Safety

Tel: 886-3-3183232

Fax: 886-3-3270892

Email: service.adt@tw.bureauveritas.com

Web Site: www.bureauveritas-adt.com

The address and road map of all our labs can be found in our web site also.

--- END ---