

# VHF WIRELESS MICROPHONE

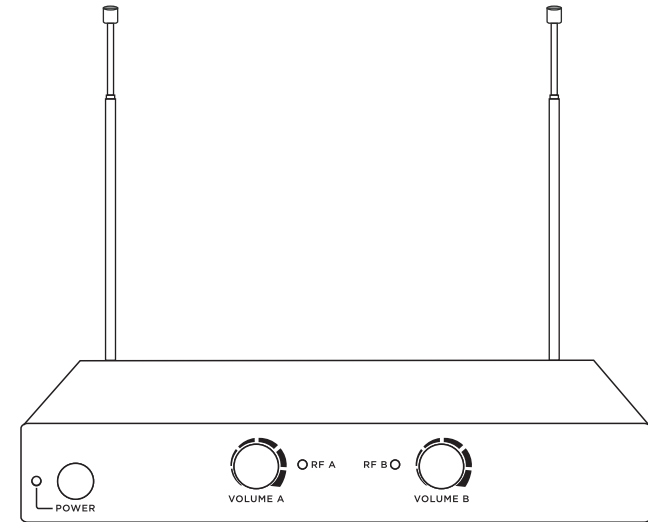

## USER'S MANUAL

**PLEASE READ THIS MANUAL CAREFULLY BEFORE OPERATION**

## SPECIFICATIONS

### Receiver

Frequency Range: 177.6MHz or 186.6MHz or 198.6MHz or 204.6MHz  
Frequency Stability: 10PPM  
Sensitivity: -92dBm  
Frequency Response: 80Hz~12KHz  
Audio Output Level: 150mV(RMS)  
S/N: >75dB  
Distortion: <1%  
Power Supply: DC 9V 200mA  
Current Consumption: 150mA

### Transmitter

Frequency Range: 177.6MHz or 186.6MHz or 198.6MHz or 204.6MHz  
Frequency Stability: 10ppm  
RF Output: <10mW  
Modulation: FM  
Max Deviation:  $\pm 75$ KHz  
Harmonic Suppression : >45dB  
Power Supply: 3V(2xAA batteries)  
Current Consumption: 100mA

## RECEIVER

### Parts Description

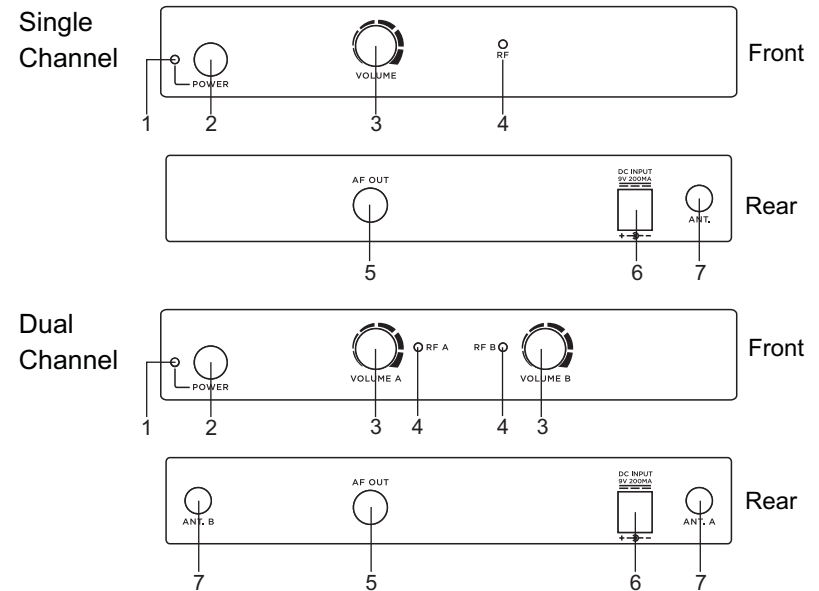

1. Power Indicator
2. ON/OFF Switch
3. Volume Control
4. RF Indicator
5. 1/4" unbalanced output jack
6. DC input jack
7. Antenna

### Operation

1. Connect one end of supplied 6.35mm to 6.35mm plug audio cable into AF OUT jack on rear panel of the receiver. Connect the other end of the audio cable into "MIC IN" or "AUX IN" of amplifier or mixer.
2. Connect DC plug of supplied AC/DC adapter to DC INPUT jack on rear panel of the receiver. Connect AC plug of AC/DC adapter to mains power socket.
3. Press ON/OFF button on front panel to turn on the receiver.
4. Extend antenna fully.
5. Turn on the transmitter. RF indicator on receiver will light.
6. Adjust receiver volume and your amplifier or mixer volume to suitable level.

# BELT PACK TRANSMITTER

## Parts Description

1. Power ON/OFF/MUTE Switch
2. Power/low battery Indicator
3. MIC in jack
4. Battery Compartment/Cover

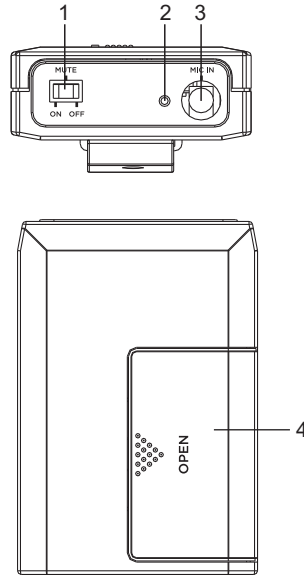

## Operation

1. Open battery cover. Install the provided 2pcs 1.5V AA batteries and then close the cover. Pay attention to the correct polarity.
2. Insert headset MIC or clip-on MIC plug into MIC IN jack. And turn plug clockwise to lock the headset MIC.
3. Slide power switch to ON position, power indicator should flash once briefly indicating that the transmitter has sufficient power. If the power LED indicator stays on, it indicates that the battery has insufficient power and should be changed. If the power LED indicator does not light at all and the transmitter does not work, it indicates the battery is dead and you should change the battery.
4. Now receiver RF indicator should light. Please confirm frequency of transmitter is same as receiver before operation.
5. Slide power switch to MUTE position to mute the sound.
6. If the transmitter is not going to be used for any length of time, push the power switch to OFF position and remove the battery.

NOTE: This equipment has been tested and found to comply with the limits for a Class B digital device, pursuant to part 15 of the FCC Rules. These limits are designed to provide reasonable protection against harmful interference in a residential installation. This equipment generates, uses and can radiate radio frequency energy and, if not installed and used in accordance with the instructions, may cause harmful interference to radio communications. However, there is no guarantee that interference will not occur in a particular installation. If this equipment does cause harmful interference to radio or television reception, which can be determined by turning the equipment off and on, the user is encouraged to try to correct the interference by one or more of the following measures:

- Reorient or relocate the receiving antenna.
- Increase the separation between the equipment and receiver.
- Connect the equipment into an outlet on a circuit different from that to which the receiver is connected.
- Consult the dealer or an experienced radio/TV technician for help.

This device complies with part 15 of the FCC rules. Operation is subject to the following two conditions:

- (1) this device may not cause harmful interference, and
- (2) this device must accept any interference received, including interference that may cause undesired operation.

Changes or modifications to this unit not expressly approved by the party responsible for compliance could void the user's authority to operate the equipment.

The device meets RF Exposure requirements without any restriction.