

size:105x148mm

USER MANUAL

gemini[®]
GSYS-T2115



CONTENTS

Product Introduction	3
Caution.....	3
Panel.....	5
Remote control.....	6
Bluetooth Mode.....	7
Twos mode.....	7
USB Mode	8
LINE IN Mode.....	8
MIXING SOUND WITH MICROPHONE.....	8
Specifications	8
Warranty information.....	9
Legality and Safety.....	10
Spanish.....	11
French.....	15
German.....	19
Italian.....	25
Dutch.....	30

Introduction

Thank you for purchasing our GSYS Series Complete High-Power Speaker System. With proper care & maintenance, your unit will provide years of reliable, uninterrupted service. The GSYS Series is backed by a 1-year limited warranty*.

Preparing For First Use

Please ensure that you find these accessories included with your GSYS Series speaker:

- (1) Speaker
- (1) Power cable
- (1) Operating Instructions
- (1) FM Antenna
- (1) Remote control
- (1) Wired microphone

Caution

- (i) All operating instructions should be read before using this equipment.
- (ii) To reduce the risk of electrical shock, do not open the unit. There are no user replaceable parts inside. Please refer servicing to a qualified GEMINI service technician. Do not attempt to return this equipment to your dealer.
- (iii) Do not expose this unit to direct sunlight or to a heat source such as a radiator or stove.
- (iv) This unit should be cleaned only with a damp cloth. Avoid solvents or other cleaning detergents.
- (v) When moving this equipment, it should be placed in its original carton and packaging. This will reduce the risk of damage during transit.
- (vi) Do not expose this unit to water or heat.
- (vii) Do not use cleaning products or lubricants on the controls or switches.

Precautions**Please read carefully before proceeding**

Always follow the basic precautions listed below to avoid the possibility of serious injury or even death from electrical shock, short-circuiting, damages, fire, or other hazards.

• *Read Instructions:* All the safety and operating instructions should be read before the product is operated.

• *Retain Instructions:* The safety and operating instructions should be retained for future reference. All the safety and operating instructions should be read before the product is operated.

• *Heed Warnings:* All warnings on the product and in the operating instructions should be adhered to.

• *Follow Instructions:* All operating and use instructions should be followed.

• *Cleaning:* The product should be cleaned only with a polishing cloth or a soft dry cloth. Never clean with furniture wax, benzene, insecticides or other volatile liquids since they may corrode the cabinet.

• *Water And Moisture:* Do not use this product near water, for example, near a bathtub, wash bowl, kitchen sink, or Laundry tub; in a wet basement; or near a swimming pool; and the like.

• *Do Not Open:* Do not open the device or attempt to disassemble the internal parts or modify them in any way. The device contains no user-serviceable parts. If it should appear to be malfunctioning, discontinue use immediately and have it inspected by qualified GEMINI service personnel.

• *Replacement Parts:* When replacement parts are required, be sure the service technician has used replacement parts specified by the manufacturer or have the same characteristics as the original part. Unauthorized substitutions may result in fire, electric shock, or other hazards.

• *Location:* Before moving the device, remove all connected cables.

-Do not use the speaker's handles for suspended installation.

Doing so can result in damage or injury.

-Do not expose the device to excessive dust or vibrations, or extreme cold or heat (such as in direct sunlight, near a heater) to prevent the possibility of panel disfiguration or damage to the internal components.

-Do not place the device in an unstable position where it may accidentally fall over.

• *Connections:* Before connecting the device to other devices, turn off the power for all devices. Before turning the power on or off for all devices, set all volume levels to minimum.

Panel

1. FM ANTENNA :

Connect included antenna for FM radio

2. MIC 1/2 :

1/4" wired microphone input jack

3. POWER light

4. USB :

Play MP3 or WAV files from USB

5. POWER SWITCH :

Switch power between ON or OFF.

6. AC INPUT:

AC 100-240V,50/60Hz

7. X BASS :

X BASS mode increases bass for extra power, turn on or off.

8. LIGHT MODE :

Press to change the light mode between LED1,LED2,LED3, LED4,OFF. Press and hold to discoball on or off.

9. NEXT :

Press this key to go to the next track in USB/BT mode. In FM mode press to tune to the next channel

10. PLAY/PAUSE :

Press to play/pause a track. In FM mode press for the full automatic search.

11. PREV :

Press this key to go to the previous track in USB/BT mode. In FM mode press to tune to the previous channel.

12. LED DISPLAY :

Display speaker status.

13. +/-: Adjusts Volume & FX Parameters.

14. MIC.MENU:

Press this key to toggle the menu between MIC VOLUME, ECHO EFFECT, Adjust with +/- keys.

15. EFFECTS:

Press this key to toggle the menu between BASS, TREBLE, Adjust with +/- keys.

16. BT/TWS

17. STANDBY:

To suspend operations and save power when not in use, press to enter STANDBY mode. Press again to resume operation.

18. SOURCE:

Press this key to change the sources between BT, LINE, USB,FM.

19. IPOD Slot

20. Tweeter 2"

21. Discoball

22. LINE-IN: 1/8" Auxiliary audio input

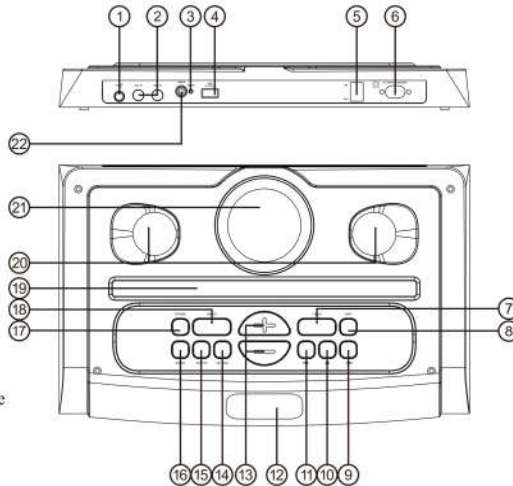

Remote Control

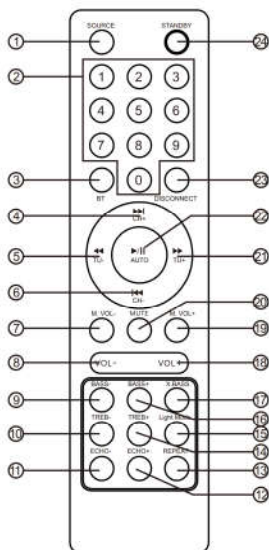

1.SOURCE

Press to change the source between USB, BT, FM, LINE.

2.0-9 NUMERIC KEYS

These keys are used to play a track directly in USB source mode.

Eg: To play 12th track in the USB playlist press the numeric key "1" followed by "2".

In FM, to select saved channel, or input station frequency directly

3.BT

Press to enter Bluetooth pairing mode.

4. ►/CH+

In USB/BT Mode: Press to play the next song
In FM Mode: Press to skip to next saved channel

5. ◀/TU-

In USB/BT Mode: Press to rewind song
IN FM Mode: Press to adjust radio frequency lower

6. ◀◀/CH-

In USB/BT Mode: Press to play the previous song
In FM Mode: Press to skip to previous saved channel

7.MIC VOL-

Decrease MIC volume.

8.VOL-

Decrease the volume.

9.BASS-

Reduce BASS frequency EQ

10.TREB-

Reduce TREBLE frequency EQ

11.ECHO-

Decrease the echo effect

12.ECHO+

Increase the echo effect

13.REPEAT (USB mode only)

Press to choose repeat mode (Random, Single, Repeat All)

14.TREB+

Increase TREBLE frequency EQ

15.Light mode

Change the light mode between LED1, LED2, LED3, LED4, OFF

16.BASS+

Increase BASS frequency EQ

17.X BASS

Press this key to turn ON/OFF Extra Bass Mode

18.VOL+

Increase the volume.

19.MIC VOL+

Increase MIC volume

20.MUTE

Press to MUTE/UNMUTE the speaker playback

21. ►►/TU+

In USB/BT Mode: Press to fast forward song
In FM Mode: Press to adjust radio frequency higher

22. ►/AUTO

In USB/BT Mode: Play/Pause
In FM Mode: Press for full automatic search of radio frequencies.





23.DISCONNECT (BT MODE)

Press to disconnect and pair with a new device.









24.STANDBY

Press to put speaker in Standby mode

BLUETOOTH MODE

<p>1</p>  <p>Set the switch to ON position</p>	<p>2</p>  <p>Press the SOURCE button until "BT" appears blinking on the screen.</p>	<p>3</p>  <p>Search for GEMINI GSYS-T2115 in the Bluetooth options of the mobile device</p>	<p>4</p>  <p>"BT" fixed on the screen. Connection successful.</p>
---	--	--	--

TWS

<p>1</p> 	<p>2</p> 	
<p>1</p>  <p>Turn on both speakers</p>	<p>Press the SOURCE button on both speakers until they enter Bluetooth mode (Screen shows "BT" blinking)</p>	
<p>3</p>  <p>Press and hold the TWS button, and "TON" will appear on the screen of both speakers.</p>		<p>4</p>  <p>"beep"</p> <p>You will hear "beep" on both speakers</p>
		<p>5</p>  <p>One of the speakers will continue to show "BT" blinking on the screen, while the other will have "BT" fixed</p>
<p>6</p>  <p>Search for GEMINI GSYS-T2115 in the Bluetooth options of the mobile device</p>		

USB MODE

1



Set the switch to ON position

2

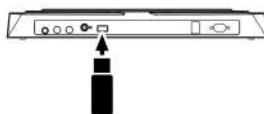

3



USB

Press the SOURCE button until "USB" appears on the screen

LINE IN MODE

1

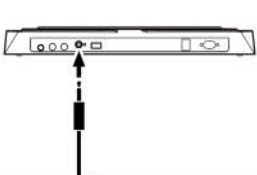

2



MIXING SOUND WITH MICROPHONE

1

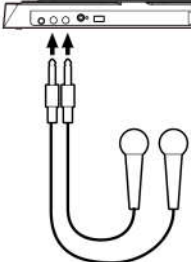

Connect dynamic microphone to 1/4" input

2



2000

To adjust Mic volume, press MIC MENU button once, display will read "2U***"

3

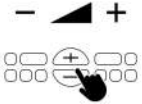

Use the + & - buttons to adjust microphone volume

Warranty and Repair

All Gemini products are designed and manufactured to the highest standards in the industry. With proper care and maintenance, your product will provide years of reliable service.

Limited Warranty

- a. GEMINI guarantees its products to be free from defects in materials and workmanship for one (1) year from the original purchase date.
- b. This limited warranty does not cover damage or failure caused by abuse, misuse, abnormal use, faulty installation, improper maintenance or any repairs other than those provided by an authorized Gemini Service Center
- c. There are no obligations of liability on the part of GEMINI for consequential damages arising out of or in connection with the use or performance of the product or other indirect damages with respect to loss of property, revenues, of profit, or costs of removal, installation, or reinstallation. All implied warranties for GEMINI, including implied warranties for fitness, are limited in duration to one (1) year from the original date of purchase, unless otherwise mandated by local statutes.

Return/Repair

- a. Please call our helpful Customer Service Representatives at 732-346-0061, and they will be happy to give you a Return Authorization Number (RMA) and the address of an authorized service center closest to you.
- b. After receiving an RMA, include a copy of the original sales receipt, with defective product and a description of the defect. Send by insured freight to: Gemini and use the address provided by your customer service representative. Your RMA must be written on the outside of the package, or processing will be delayed indefinitely!
- c. Service covered under warranty will be paid for by Gemini and returned to you. For non-warranted products, Gemini will repair your unit after payment is received. Repair charges do not include return freight. Freight charges will be added to the repair charges.
- d. On warranty service, you pay for shipping to Gemini, we pay for return shipping within the continental United States. Alaska, Hawaii, Puerto Rico, Canada, Bahamas, and the Virgin Islands will be charged for freight.
- e. Please allow 2-3 weeks for return of your product. Under normal circumstances your product will spend no more than 10 working days at Gemini. We are not responsible for shipping times.

LEGALITY & SAFETY

The device is not intended for use by people (including children) with reduced physical, sensory or mental capacity. People who have not read the manual, unless they have received an explanation by someone responsible for their safety, should not use this unit. Children should be monitored to ensure that they do not play with the device. The device should always be readily accessible. The device should not be exposed to water. No objects filled with liquids, such as vases, shall be placed on the device. Always leave a minimum distance of 10 cm around the unit to ensure sufficient ventilation. Open flame sources, such as candles, should not be placed on top of the device. The device is intended for use only in a temperate climate. At full volume, prolonged listening may damage your hearing and cause temporary or permanent deafness, hearing drone, tinnitus, or hyperacusis. Listening at high volume is not recommended. One hour per day is not recommended either. Switch the device off where the use of the device is not allowed or where there is a risk of causing interference or danger - for examples: on an aircraft, or near medical equipment, fuel, chemicals or blasting sites. Check the current laws and regulations regarding the use of this device in the areas where you drive. Do not handle the device when driving. Concentrate fully on driving. All wireless devices are susceptible to interference which may affect their performance. All our devices conform to international/national standards and regulations, and we aim to limit user exposure to electromagnetic fields. These standards and regulations were adopted after the completion of extensive scientific research. This research established no link between the use of the mobile headset and any adverse effects on health if the device is used in accordance with standard practices. Only qualified people are authorized to install or repair this product. Only use batteries, chargers and other accessories which are compatible with this equipment. Do not connect incompatible products. This equipment is not waterproof. Keep it dry. Keep your device in a safe place, out of the reach of young children. The device contains small parts which may present a choking hazard to kids.

Panel

1. **ANTENA FM:**
Conecte la antena incluida para Radio FM
2. **MIC 1/2:**
Conector de entrada de micrófono con cable de 1/4"
3. **LUZ DE ENCENDIDO**
4. **USB:**
Reproduce archivos MP3 o WAV desde USB
5. **INTERRUPTOR DE ENCENDIDO:**
Encienda o apague.
6. **ENTRADA DE CA:**
CA 100-240V, 50/60Hz
7. **X BASS:**
El modo X BASS aumenta los graves para obtener potencia adicional, enciéndalos o apáguelos.
8. **MODO DE LUZ:**
Presione para cambiar el modo de luz entre LED1, LED2, LED3, LED4, APAGADO.
Presione y mantenga para abrir o cerrar la discoteca.
9. **PRÓXIMO:**
Presione esta tecla para ir a la siguiente pista en modo USB/BT. En el modo FM, presione para sintonizar el siguiente canal
10. **REPRODUCIR/PAUSAR:**
Presione para reproducir/pausar una pista. En el modo FM, presione para la búsqueda automática completa.
11. **PREV:**
Presione esta tecla para ir a la pista anterior en modo USB/BT. En el modo FM, presione para sintonizar el canal anterior.
12. **PANTALLA LED:**
Muestra el estado del altavoz.
13. **-/+:**
Ajusta los parámetros de volumen y efectos.
14. **MIC.MENU:**
Presione esta tecla para alternar el menú entre VOLUMEN DEL MICRÓFONO, EFECTO DE ECO. Ajustar con +/-.
15. **EFFECTOS:**
Presione esta tecla para alternar el menú entre BASS, TREBLE, Ajustar con las teclas +/-.
16. **BT/TWS**
17. **STANDBY:**
Para suspender las operaciones y ahorrar energía cuando no esté en uso, presione para ingresar al modo STANDBY. Presione nuevamente para reanudar la operación.
18. **FUENTE:**
Presione esta tecla para cambiar las fuentes entre BT, LINE, USB, FM.
19. **Ranura para iPod**
20. **Tweeter 2"**
21. **Discoball**
22. **ENTRADA DE LÍNEA:** Entrada de audio auxiliar de 1/8"

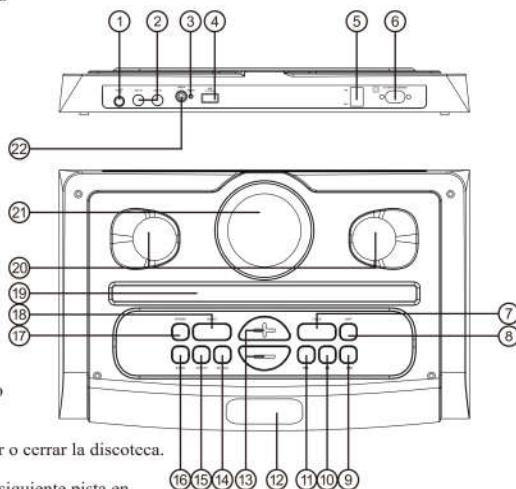



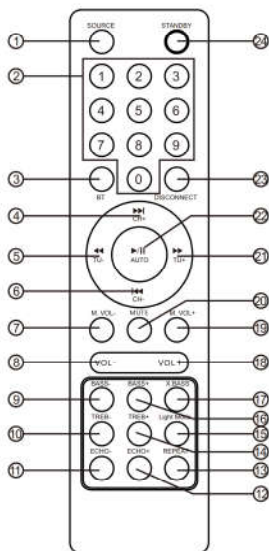

Remote Control















- FUENTE**
Presione para cambiar la fuente entre USB, BT, FM, LINE.
- 0-9 TECLAS NUMÉRICAS**
Estas teclas se utilizan para reproducir una pista directamente en el modo de fuente USB.
Por ejemplo: Para reproducir la pista 12 en la lista de reproducción USB, presione la tecla numérica "1" seguida de "2". En FM, para seleccionar el canal guardado o ingresar la frecuencia de la estación directamente
- BT**
Presione para ingresar al modo de emparejamiento Bluetooth.
- ▶▶/CH+**
En modo USB/BT: Presione para reproducir la siguiente canción
En modo FM: Presione para saltar al siguiente canal guardado
- ◀◀/TU-**
En modo USB/BT: Presione para rebobinar la canción
Modo IN FM: Presione para ajustar la frecuencia de radio más baja
- ◀◀/CH-**
En modo USB/BT: Presione para reproducir la canción anterior
En modo FM: Presione para saltar al canal guardado anterior
- MIC VOL**
Deducta el volumen del MIC.
- VOL**
Daumenta el volumen.
- BASS-**
Ecuador de frecuencia BASS Reduce BASS
- TREB-**
Ecuador de frecuencia TREB Reduce TREBLE
- ECHO-**
Disminuir el efecto de eco
- ECHO+**
Aumentar el efecto de eco
- REPEAT (solo modo USB)**
Presione para elegir el modo de repetición (Aleatorio, Único, Repetir todo)
- TREB+**
Aumentar el ecualizador de frecuencia de agudos
- MODO DE LUZ**
Cambie el modo de luz entre LED1, LED2, LED3, LED4, OFF
- BAJO+**
Aumentar el ecualizador de frecuencia de BASS
- X BAJO**
Presione esta tecla para activar / desactivar el modo de graves adicionales
- VOL+**
Aumenta el volumen.
- MIC VOL+**
Aumentar el volumen del micrófono
- MUDO**
Presione para MUTE/UNMUTE la reproducción del altavoz
- ▶▶/TU-**
En modo USB/BT: Presione para avanzar rápidamente la canción
En modo FM: Presione para ajustar la frecuencia de radio más alta
- ▶▶/AUTOMÁTICO**
En modo USB/BT: Reproducir/Pausar
En modo FM: Presione para una búsqueda automática completa de frecuencias de radio.
- DESCONECTAR (MODO BT)**
Presione para desconectar y emparejar con un nuevo dispositivo.
- STANDBY**
Presione para poner el altavoz en modo de espera

BLUETOOTH MODE

<p>1</p>  <p>Coloque el interruptor en la posición ON</p>	<p>2</p>  <p>Presione el botón SOURCE hasta que aparezca "BT" parpadeando en la pantalla.</p>	<p>3</p>  <p>Busque GEMINI GSYS-T2115 en las opciones de Bluetooth del dispositivo móvil</p>	<p>4</p>  <p>"BT" fijado en la pantalla. Conexión exitosa.</p>
--	--	---	---

TWS

<p>1</p> 	<p>2</p>  <p>Presione el botón SOURCE en ambos altavoces hasta que entren en modo Bluetooth (la pantalla muestra "BT" parpadeando)</p>		
<p>1</p>  <p>Enciende ambos altavoces</p>	<p>2</p> 		
<p>3</p>  <p>Al presionar el botón TWS se mostrará "ton" En la pantalla de dos altavoces.</p>	<p>3</p> 	<p>4</p>  <p>"beep"</p> <p>Escuchará un "bip" en ambos altavoces.</p>	<p>4</p>  <p>"beep"</p>
<p>3</p> 	<p>3</p> 	<p>5</p>  <p>Uno de los altavoces seguirá mostrando el parpadeo "bt" En pantalla, mientras que el otro fijará "bt"</p>	<p>5</p> 
<p>6</p>  <p>Busque GEMINI GSYS-T2115 en las opciones de Bluetooth del dispositivo móvil</p>			

USB MODE

1



coloque el interruptor en la posición ON

2

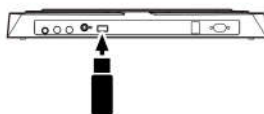

3



USB

Presione el botón FUENTE hasta que aparezca "USB" en la pantalla

LINE IN MODE

1

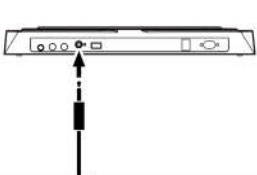

2



MIXING SOUND WITH MICROPHONE

1

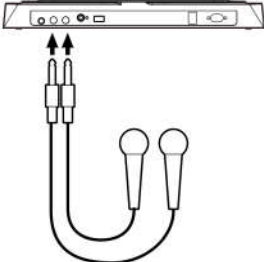

Conecte el micrófono dinámico a la entrada de 1/4"

2

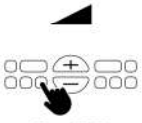

2000

Para ajustar el volumen del micrófono, presione el botón MIC MENU una vez, en la pantalla se leerá "2U**"

3

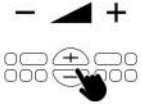

Use el botón +/- para ajustar Volumen del micrófono

PANNEAU

1. **ANTENNE FM :**
Connectez l'antenne incluse pour la radio FM
2. **MIC 1/2 :**
Prise d'entrée microphone avec câble 1/4"
3. **LUMIÈRE D'ALIMENTATION**
4. **L'USB :**
Lire des fichiers MP3 ou WAV à partir d'une clé USB
5. **INTERRUPTEUR D'ALIMENTATION :**
Activer ou désactiver.
6. **ENTRÉE CA :**
CA 100-240 V, 50/60 Hz
7. **X BASSE ;**
Le mode X BASS amplifie les basses pour plus de puissance, activez-le ou désactivez-le.
8. **MODE LUMINEUX :**
Appuyez pour basculer le mode d'éclairage entre LED1, LED2, LED3, LED4, OFF. Appuyez et maintenez enfoncé pour ouvrir ou fermer la discothèque.
9. **SUIVANT :**
Appuyez sur cette touche pour passer à la piste suivante en mode USB/BT. En mode FM, appuyez pour syntoniser la chaîne suivante
10. **LECTURE/PAUSE :**
Appuyez sur cette touche pour lire/mettre en pause une piste. En mode FM, appuyez sur pour une recherche entièrement automatique.
11. **PRÉCÉDENT :**
Appuyez sur cette touche pour passer à la piste précédente en mode USB/BT. En mode FM, appuyez sur pour syntoniser la chaîne précédente.
12. **AFFICHAGE LED :**
Affiche l'état du haut-parleur.
13. **-/+ :**
Ajustez les paramètres de volume et d'effets.
14. **MICRO.MENU :**
Appuyez sur cette touche pour basculer le menu entre VOLUME DU MICROPHONE, EFFET D'ÉCHO, Réglage avec +/-.
15. **EFFETS :**
Appuyez sur cette touche pour basculer le menu entre les touches BASS, TREBLE, Adjust avec +/-.
16. **BT/TWS**
17. **VEILLE :**
Pour suspendre les opérations et économiser de l'énergie lorsqu'elles ne sont pas utilisées, appuyez sur pour entrer en mode STANDBY. Appuyez à nouveau pour reprendre l'opération.
18. **LA SOURCE :**
Appuyez sur cette touche pour basculer les polices entre BT, LINE, USB, FM.
19. **Emplacement pour iPod**
20. **Haut-parleur d'aigus 2"**
21. **Boule disco**
22. **ENTRÉE DE LIGNE :** Entrée audio auxiliaire 1/8"

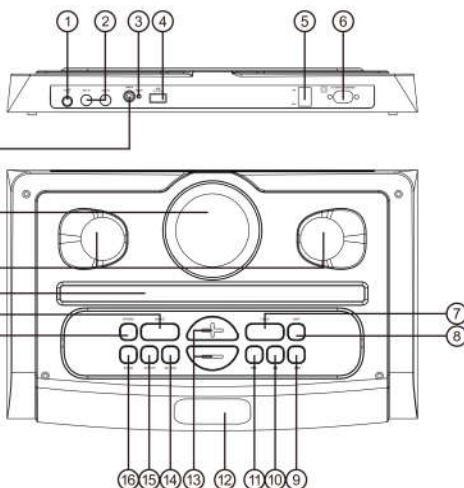

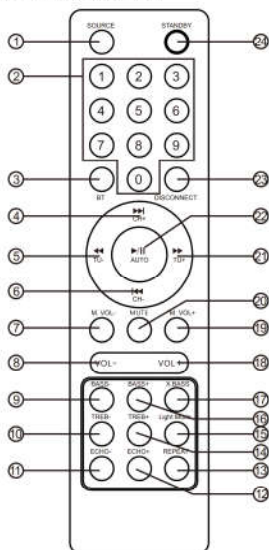

TÉLÉCOMMANDE













- LA SOURCE**
Appuyez sur cette touche pour basculer la source entre USB, BT, FM, LINE.
- 0 ~ 9 TOUCHES NUMÉRIQUES**
Ces touches permettent de lire une piste directement en mode source USB. Par exemple : Pour lire la piste 12 de la liste de lecture USB, appuyez sur la touche numérique « 1 » suivie de « 2 ». Sur FM, pour sélectionner le canal enregistré ou entrer directement la fréquence de la station
- BT**
Appuyez sur cette touche pour accéder au mode d'appairage Bluetooth.
- ▶▶/CH+**
En mode USB/BT : appuyez pour lire la chanson suivante
En mode FM : Appuyez pour passer à la chaîne enregistrée suivante
- ◀◀/VOUS-**
En mode USB/BT : appuyez pour rembobiner le morceau
En mode FM : Appuyez pour régler la fréquence radio la plus basse
- ◀◀/CH-**
En mode USB/BT : Appuyez pour lire la chanson précédente
- VOL DU MICRO**
Déduisez le volume du MIC.
- VOL**
Diminuez le volume.
- BASSE-**
Egaliseur de fréquence BASS Réduire les basses
- TREB-**
Egaliseur de fréquence TREBLE Reduce TREBLE
- ÉCHO-**
Diminuer l'effet d'écho
- ÉCHO+**
Augmenter l'effet d'écho
- REPEAT (mode USB uniquement)**
Appuyez pour choisir le mode de lecture (Aléatoire, Simple, Répéter tout)
- TREB+**
Augmenter l'égaliseur de fréquence des aigus
- MODE LUMIÈRE**
Changez le mode d'éclairage entre LED1, LED2, LED3, LED4, OFF
- FAIBLE+**
Augmenter l'égaliseur de fréquence BASS
- FAIBLE X**
Appuyez sur cette touche pour activer/désactiver le mode de basses supplémentaires
- VOL+**
Montez le volume.
- MIC VOL+**
Augmenter le volume du microphone
- Couper le son**
Appuyez sur cette touche pour activer le son du haut-parleur
- ▶▶/VOUS-**
En mode USB/BT : appuyez pour avancer rapidement le morceau
En mode FM : Appuyez sur cette touche pour régler la fréquence radio la plus élevée
- ▶▶/AUTOMATIQUE**
En mode USB/BT : Lecture/Pause
En mode FM : Appuyez sur cette touche pour une recherche entièrement automatique des fréquences radio.
- DÉCONNEXION (MODE BT)**
Appuyez sur cette touche pour vous déconnecter et l'appairer avec un nouvel appareil.
- DEBOUT**
Appuyez pour mettre le haut-parleur en mode veille

En mode FM : Appuyez pour revenir à la chaîne enregistrée précédente

MODE BLUETOOTH

<p>1</p>  <p>Tournez l'interrupteur en position ON</p>	<p>2</p>  <p>bt ★ ○ ★</p> <p>Appuyez sur le bouton SOURCE jusqu'à ce que « BT » clignote à l'écran.</p>	<p>3</p>  <p>Recherchez GEMINI GSYS-T2115 dans les options Bluetooth de votre appareil mobile</p>	<p>4</p> <p>bt ★</p> <p>« BT » épinglé à l'écran. Connexion réussie.</p>
---	--	--	--

TWS (en anglais seulement)

<p>1</p> 	 <p>2</p> 	<p>2</p> 	
<p>1</p>  <p>Allumez les deux haut-parleurs</p>		 <p>bt ★ ○ ★</p> <p>Appuyez sur le bouton SOURCE des deux haut-parleurs jusqu'à ce qu'ils passent en mode Bluetooth (l'écran affiche « BT » clignotant)</p>	
<p>3</p>  <p>ton</p> <p>Maintenez le bouton TWS enfoncé et "ton" s'affichera. Sur l'écran des deux Haut - parleurs.</p>	 <p>ton</p>	<p>4</p>  <p>"beep"</p> <p>Vous entendrez un « bip » sur les deux haut-parleurs.</p>	 <p>"beep"</p>
<p>6</p>  <p>Recherchez GEMINI GSYS-T2115 dans les options Bluetooth de votre appareil mobile</p>		<p>5</p> <p>bt ★ ○ ★</p>	<p>bt ★</p> <p>L'un des haut-parleurs affichera toujours « BT » clignotant à l'écran, tandis que l'autre aura « BT » fixe.</p>

MODE USB

1



réglez l'interrupteur sur la position ON

2

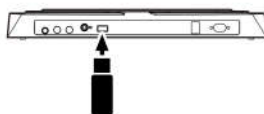

3



USB

Appuyez sur le bouton SOURCE jusqu'à ce que « USB » apparaisse à l'écran

MODE D'ENTRÉE AUXILIAIRE

1

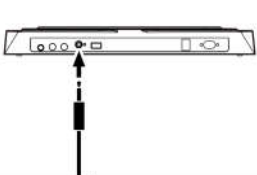

2



MIXAGE DU SON AVEC LE MICROPHONE

1

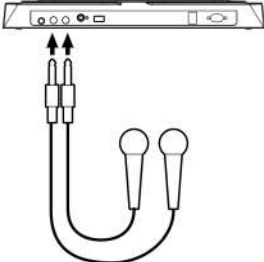

Connectez le microphone dynamique à l'entrée 1/4"

2



2000

Pour régler le volume du microphone, appuyez une fois sur le bouton MIC MENU, l'écran affichera « 2U** »

3

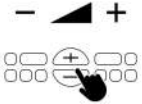

Utilisez les boutons + et - pour régler le volume du microphone

TAFEL

1. **UKW-ANTENNE:**
Schließen Sie die mitgelieferte Antenne für UKW-Radio an
2. **MIC 1/2:**
Mikrofoneingangsbuchse mit 1/4" -Kabel
3. **POWER-LICHT**
4. **USB-Anschluss:**
MP3- oder WAV-Dateien von USB abspielen
5. **NETZSCHALTER:**
Schalten Sie es ein oder aus.
6. **AC-EINGANG:**
Wechselstrom 100-240 V, 50/60 Hz
7. **X BASS:**
Der X BASS-Modus verstärkt den Bass für zusätzliche Leistung, schalten Sie ihn ein oder aus.
8. **LICHT-MODUS:**
Drücken Sie diese Taste, um den Lichtmodus zwischen LED1, LED2, LED3, LED4, OFF umzuschalten. Halten Sie die Taste gedrückt, um Discoball ein- oder auszuschalten.
9. **WEITER:**
Drücken Sie diese Taste, um zum nächsten Titel im USB/BT-Modus zu wechseln. Drücken Sie im FM-Modus, um den nächsten Kanal einzustellen
10. **WIEDERGABE/PAUSE:**
Drücken Sie diese Taste, um einen Titel abzuspielen/anzuhalten. Drücken Sie im FM-Modus für die vollautomatische Suche.
11. **PREV:**
Drücken Sie diese Taste, um im USB/BT-Modus zum vorherigen Titel zu wechseln. Drücken Sie im FM-Modus, um den vorherigen Kanal einzustellen.
12. **LED-ANZEIGE:**
Zeigt den Status des Lautsprechers an.
13. **-/+:**
Passen Sie die Lautstärke- und Effektparameter an.
14. **MIC.MENÜ:**
Drücken Sie diese Taste, um das Menü zwischen MIKROFONLAUTSTÄRKE, ECHOEFFEKT und Anpassen mit +/- umzuschalten.
15. **EFFEKTE:**
Drücken Sie diese Taste, um das Menü zwischen den Tasten BASS, TREBLE und Adjust mit +/- umzuschalten.
16. **BT/TWS**
17. **STANDBY:**
Um den Betrieb zu unterbrechen und Strom zu sparen, wenn er nicht verwendet wird, drücken Sie, um in den STANDBY-Modus zu wechseln. Drücken Sie erneut, um den Vorgang fortzusetzen.
18. **QUELLE:**
Drücken Sie diese Taste, um die Schriftarten zwischen BT, LINE, USB und FM umzuschalten.
19. **iPod-Steckplatz**
20. **Hochtöner 2"**
21. **Discoball**
22. **ZEILENEINGANG:** 1/8" AUX-Audioeingang

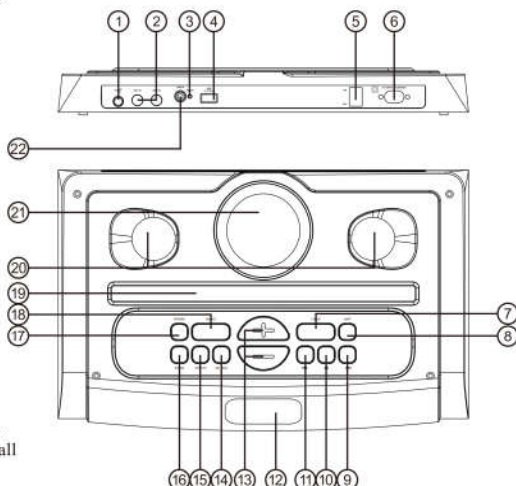

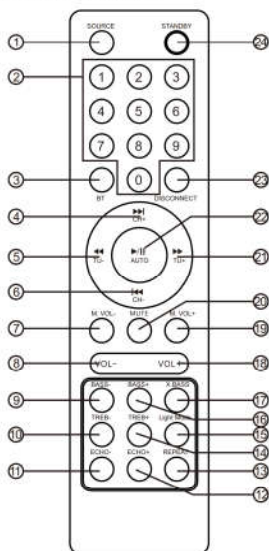

FERNBEDIENUNG









- 1. QUELLE**
Drücken Sie diese Taste, um die Quelle zwischen USB, BT, FM und LINE umzuschalten.
- 2. 0 - 9 ZAHLENTASTEN**
Diese Tasten werden verwendet, um einen Titel direkt im USB-Quellenmodus abzuspielen. Zum Beispiel: Um Titel 12 in der USB-Wiedergabeliste abzuspielen, drücken Sie die Zifferntaste "1" gefolgt von "2". Auf UKW, um den gespeicherten Kanal auszuwählen oder die Senderfrequenz direkt einzugeben
- 3. BT**
Drücken Sie diese Taste, um in den Bluetooth-Kopplungsmodus zu wechseln.
- 4. ►►/CH+**
Im USB/BT-Modus: Drücken Sie diese Taste, um den nächsten Song abzuspielen
Im FM-Modus: Drücken Sie diese Taste, um zum nächsten gespeicherten Kanal zu springen
- 5. ◀◀/SIE-**
Im USB/BT-Modus: Drücken Sie diese Taste, um den Song zurückzuspulen
Im FM-Modus: Drücken Sie diese Taste, um die niedrigste Radiofrequenz einzustellen
- 6. ◀◀/CH-**
Im USB/BT-Modus: Drücken Sie diese Taste, um den vorherigen Song abzuspielen
- 7. MIC VOL**
Leiten Sie die Lautstärke des Mikrofons ab.
- 8. VOL**
Verringern Sie die Lautstärke.
- 9. BASS-**
BASS Frequenz-EQ BASS reduzieren
- 10. TREB-**
TREB Reduce TREBLE Frequenz-Equalizer
- 11. ECHO-**
Verringern des Echoeffekts
- 12. ECHO+**
Verstärken Sie den Echo-Effekt
- 13. WIEDERHOLEN (nur USB-Modus)**
Drücken Sie diese Taste, um den Wiedergabemodus auszuwählen (Shuffle, Single, Repeat All)
- 14. TREB+**
Höhenfrequenz-EQ erhöhen
- 15. LICHT-MODUS**
Wechseln Sie den Lichtmodus zwischen LED1, LED2, LED3, LED4, OFF
- 16. NIEDRIG+**
Erhöhen Sie den BASS-Frequenz-EQ
- 17. NIEDRIG X**
Drücken Sie diese Taste, um den zusätzlichen Bassmodus zu aktivieren/deaktivieren
- 18. VOL+**
Drehen Sie die Lautstärke auf.
- 19. MIC VOL+**
Erhöhen Sie die Lautstärke des Mikrofons
- 20. MUTE**
Drücken Sie diese Taste für die Wiedergabe von MUTE/UNMUTE-Lautsprechern
- 21. ►►/SIE-**
Im USB/BT-Modus: Drücken Sie diese Taste, um den Song vorzuspulen
Im FM-Modus: Drücken Sie diese Taste, um die höchste Radiofrequenz einzustellen
- 22. ►►/AUTOMATISCH**
Im USB/BT-Modus: Wiedergabe/Pause
Im FM-Modus: Drücken Sie diese Taste für eine vollautomatische Suche nach Radiofrequenzen.
- 23. TRENNEN (BT-MODUS)**
Drücken Sie diese Taste, um die Verbindung zu trennen und mit einem neuen Gerät zu koppeln.
- 24. STANDBY**
Drücken Sie diese Taste, um den Lautsprecher in den Standby-Modus zu versetzen

Im FM-Modus: Drücken Sie diese Taste, um zum vorherigen gespeicherten Kanal zu springen

BLUETOOTH-MODUS

<p>1</p>  <p>Drehen Sie den Schalter in die Position ON</p>	<p>2</p>  <p>bt ★ ○ ★</p> <p>Drücken Sie die SOURCE-Taste, bis "BT" auf dem Bildschirm blinkt.</p>	<p>3</p>  <p>Suchen Sie in den Bluetooth-Optionen Ihres Mobilgeräts nach GEMINI GSYS-T2115</p>	<p>4</p> <p>bt ★ ○ ★</p> <p>"BT" an das Display gepinnt. Erfolgreiche Verbindung.</p>
--	---	---	---

TWS

<p>1</p> 		<p>2</p> 	
<p>1</p>  <p>Schalten Sie beide Lautsprecher ein</p>	<p>1</p> 	<p>bt ★ ○ ★</p>	<p>bt ★ ○ ★</p> <p>Drücken Sie die SOURCE-Taste an beiden Lautsprechern, bis sie in den Bluetooth-Modus wechseln (auf dem Bildschirm blinkt "BT").</p>
<p>3</p>  <p>ton</p> <p>Maintenez le bouton TWS enfoncé et "ton" s'affichera. Sur l'écran des deux Haut parleurs.</p>		<p>4</p>  <p>"beep"</p> <p>Sie hören einen "Piepton" auf beiden Lautsprechern.</p> <p>5</p> <p>bt ★ ○ ★</p> <p>Einer der Lautsprecher zeigt immer noch "BT" auf dem Bildschirm an, während der andere "BT" fixiert hat.</p>	
<p>6</p>  <p>Suchen Sie in den Bluetooth-Optionen Ihres Mobilgeräts nach GEMINI GSYS-T2115</p>			

USB-MODUS

1



Stellen Sie den Schalter auf die Position ON

2

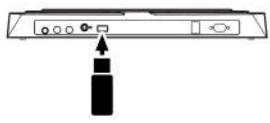

3



Drücken Sie die SOURCE-Taste, bis "USB" auf dem Bildschirm angezeigt wird

LINE-IN-MODUS

1

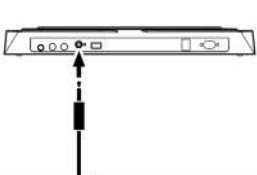

2



MISCHEN VON TON MIT MIKROFON

1

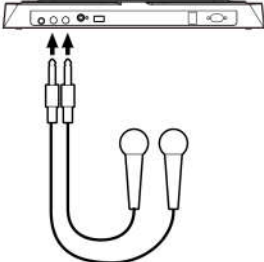

Verbinden Sie das dynamische Mikrofon mit dem 1/4"-Eingang

2



Um die Lautstärke des Mikrofons einzustellen, drücken Sie einmal die Taste MIC MENU, auf dem Display wird "2U**" angezeigt.

3

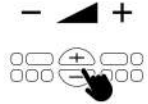

Verwenden Sie die Tasten + und -, um die Lautstärke des Mikrofons einzustellen

PANNELLO

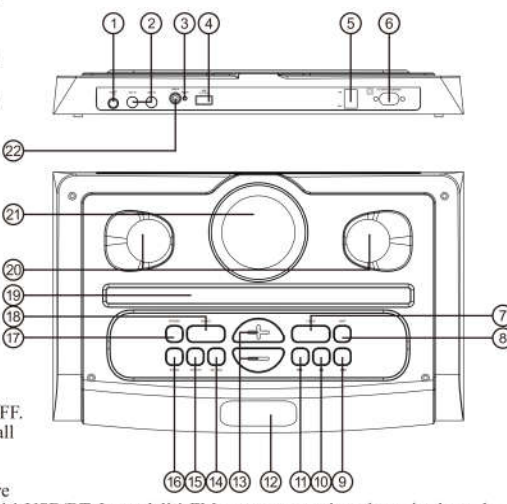
- 
1. **ANTENNA FM:**
collegare l' antenna inclusa per la radio FM
2. **MIC 1/2:**
Jack di ingresso microfono con cavo da 1/4"
3. **SPIA DI ALIMENTAZIONE**
4. **Chiavetta USB:**
Riproduci file MP3 o WAV da USB
5. **INTERRUTTORE DI ALIMENTAZIONE:**
Accendi o spegni.
6. **INGRESSO CA:**
CA 100-240 V, 50/60 Hz
7. **X BASSO;**
La modalità X BASS potenzia i bassi per una potenza extra, attivandoli o disattivandoli.
8. **MODALITÀ LUCE:**
Premere per cambiare la modalità di illuminazione tra LED1, LED2, LED3, LED4, OFF. Tenere premuto il tasto Discoball acceso o spento.
9. **PROSSIMO:**
Premere questo tasto per passare alla traccia successiva in modalità USB/BT. In modalità FM, premere per sintonizzarsi sul canale successivo.
10. **RIPRODUCI/PAUSA:**
Premere per riprodurre/mettere in pausa un brano. In modalità FM, premere per la ricerca automatica completa.
11. **PREC:**
Premere questo tasto per passare alla traccia precedente in modalità USB/BT. In modalità FM, premere per sintonizzarsi sul canale precedente.
12. **ESPOSIZIONE A LED:**
Visualizza lo stato dell'altoparlante.
13. **-/+:**
Regola i parametri del volume e degli effetti.
14. **MIC.MENU:**
Premere questo tasto per alternare il menu tra VOLUME MICROFONO, EFFETTO ECO, Regola con +/-.
15. **EFFETTI:**
Premere questo tasto per alternare il menu tra BASSI, ALTI, Regola con i tasti +/-.
16. **BT/TWS**
17. **STANDBY:**
Per sospendere le operazioni e risparmiare energia quando non è in uso, premere per accedere alla modalità STANDBY. Premere di nuovo per riprendere l'operazione.
18. **FONTE:**
Premere questo tasto per cambiare i caratteri tra BT, LINE, USB, FM.
19. **Slot per iPod**
20. **Tweeter da 2"**
21. **Palla da discoteca**
22. **INGRESSO DI LINEA:** Ingresso audio ausiliario da 1/8"



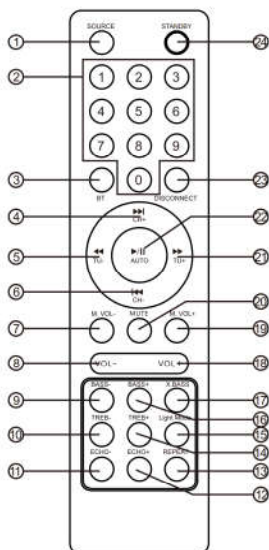

TELECOMANDO













- FONTE**
Premere per commutare la sorgente tra USB, BT, FM, LINE.
- 0 ~ 9 TASTI NUMERICI**
Questi tasti vengono utilizzati per riprodurre un brano direttamente in modalità sorgente USB. Ad esempio: per riprodurre il brano 12 nella playlist USB, premere il tasto numerico "1" seguito da "2". In FM, per selezionare il canale salvato o inserire direttamente la frequenza della stazione
- BT**
Premere per accedere alla modalità di associazione Bluetooth.
- ▶▶/CH+**
In modalità USB/BT: premere per riprodurre il brano successivo
In modalità FM: premere per passare al canale salvato successivo
- ◀◀/VOL-**
In modalità USB/BT: premere per riavvolgere il brano
In modalità FM: premere per regolare la frequenza radio più bassa
- ◀◀/CH-**
In modalità USB/BT: premere per riprodurre il brano precedente
- VOLUME MIC**
Dedurre il volume del MIC.
- VOL**
Diminuire il volume.
- BASSO-**
BASS Frequency EQ Riduci BASS
- TREB-**
TREB Riduce l'equalizzatore di frequenza TREBLE
- ECO-**
Diminuire l'effetto eco
- ECHO+**
Aumentare l'effetto eco
- REPEAT (solo modalità USB)**
Premere per scegliere la modalità di riproduzione (Casuale, Singolo, Ripeti tutto)
- TREB+**
Aumenta l'equalizzazione delle frequenze alte
- MODALITÀ LUCE**
Cambia la modalità di illuminazione tra LED1, LED2, LED3, LED4, OFF
- BASSO+**
Aumenta l'equalizzazione della frequenza dei bassi
- BASSA X**
Premere questo tasto per abilitare/disabilitare la modalità extra bass
- VOL+**
Alza il volume.
- MIC VOL+**
Aumentare il volume del microfono
- MUTO**
Premere per la riproduzione dell'altoparlante MUTE/UNMUTE
- ▶▶/VOL-**
In modalità USB/BT: premere per far avanzare velocemente il brano
In modalità FM: premere per impostare la frequenza radio più alta
- ▶▶/AUTOMATICO**
In modalità USB/BT: Riproduci/Pausa
In modalità FM: premere per una ricerca automatica completa delle frequenze radio.
- DISCONNETTI (MODALITÀ BT)**
Premere per disconnettersi e accoppiarsi con un nuovo dispositivo.
- STANDY**
Premere per mettere l'altoparlante in modalità standby

In modalità FM: premere per passare al canale salvato in precedenza

MODALITÀ BLUETOOTH

<p>1</p>  <p>Portare l'interruttore in posizione ON</p>	<p>2</p>  <p>bt * o *</p> <p>Premere il pulsante SOURCE finché "BT" non lampeggia sullo schermo.</p>	<p>3</p>  <p>Cerca GEMINI GSYS-T2115 nelle opzioni Bluetooth del tuo dispositivo mobile</p>	<p>4</p>  <p>"BT" appuntato sul display. Connessione riuscita.</p>
--	---	--	---

TWS

<p>1</p> 	<p>2</p> 	<p>2</p>  <p>bt * o *</p>	
<p>1</p>  <p>Accendi entrambi gli altoparlanti</p>		<p>Premere il pulsante SOURCE su entrambi gli altoparlanti finché non entrano in modalità Bluetooth (lo schermo mostra "BT" lampeggiante)</p>	
<p>3</p>  <p>ton</p> <p>Maintenez le bouton TWS enfoncé et "ton" s'affichera. Sur l'écran des deux Haut - parleurs.</p>	 <p>ton</p>	<p>4</p>  <p>"beep"</p> <p>Sentirai un "bip" su entrambi gli altoparlanti.</p>	 <p>"beep"</p>
		<p>5</p>  <p>bt * o *</p>	 <p>bt *</p> <p>Uno degli altoparlanti mostrerà ancora "BT" lampeggiante sullo schermo, mentre l'altro avrà "BT" fisso.</p>
<p>6</p>  <p>Cerca GEMINI GSYS-T2115 nelle opzioni Bluetooth del tuo dispositivo mobile</p>			

MODALITÀ USB

1



impostare l'interruttore in posizione ON

2

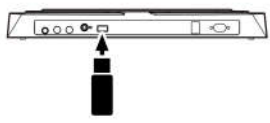

3



USB

Premere il pulsante SOURCE finché sullo schermo non viene visualizzato "USB"

MODALITÀ LINE IN

1

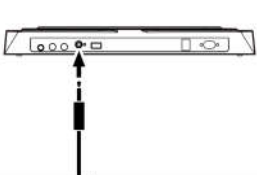

2



MIXAGGIO DEL SUONO CON IL MICROFONO

1

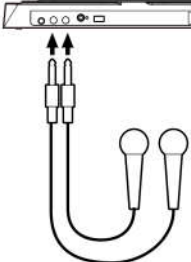

Collegare il microfono dinamico all'ingresso da 1/4"

2



2000

Per regolare il volume del microfono, premere una volta il pulsante MIC MENU, il display visualizzerà "2U**"

3

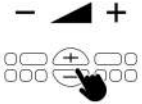

Utilizzare i pulsanti + e - per regolare il volume del microfono

PANEEL

1. **FM-ANTENNE:**
Sluit de meegeleverde antenne voor FM-radio aan
2. **MIC 1/2:**
Microfooningang met 1/4"-kabel
3. **AAN/UIT-LAMPJE**
4. **USB-poort:**
Speel MP3- of WAV-bestanden af vanaf USB
5. **AAN/UIT-SCHAKELAAR:**
In- of uitschakelen.
6. **AC-INGANG:**
Wisselstroom 100-240V, 50/60Hz
7. **X BAS:**
De X BASS-modus versterkt de bas voor extra kracht, zet hem aan of uit.
8. **LICHTE MODUS:**
Druk hierop om de lichtmodus te schakelen tussen LED1, LED2, LED3, LED4, UIT. Druk en houd deze ingedrukt om discobal in of uit te schakelen.
9. **VOLGENDE:**
Druk op deze toets om naar het volgende nummer te gaan in USB/BT-modus. Druk in de FM-modus op om af te stemmen op het volgende kanaal
10. **AFSPELEN/PAUZEREN:**
Druk op om een nummer af te spelen/pauzeren. Druk in de FM-modus op voor volledig automatisch zoeken.
11. **VORIGE:**
Druk op deze toets om naar het vorige nummer te gaan in USB/BT-modus. Druk in de FM-modus op om af te stemmen op het vorige kanaal.
12. **LED-WEERGAVE:**
Geeft de status van de luidspreker weer.
13. **-/+:**
Pas de volume- en effectparameters aan.
14. **MIC.MENU:**
Druk op deze toets om het menu te schakelen tussen MICROFOON VOLUME, ECHO-EFFECT, Aanpassen met +/-.
15. **EFFECTEN:**
Druk op deze toets om het menu te schakelen tussen BASS, TREBLE, Adjust with +/- toetsen.
16. **BT/TWS**
17. **STAND-BY:**
Om de werking te onderbreken en stroom te besparen wanneer deze niet in gebruik is, drukt u op om naar de STANDBY-modus te gaan. Druk nogmaals om de bewerking te hervatten.
18. **BRON:**
Druk op deze toets om de lettertypen te wisselen tussen BT, LINE, USB, FM.
19. **iPod-sleuf**
20. **Tweeter 2"**
21. **Discobal**
22. **LJNINGANG:**
1/8" extra audio-ingang

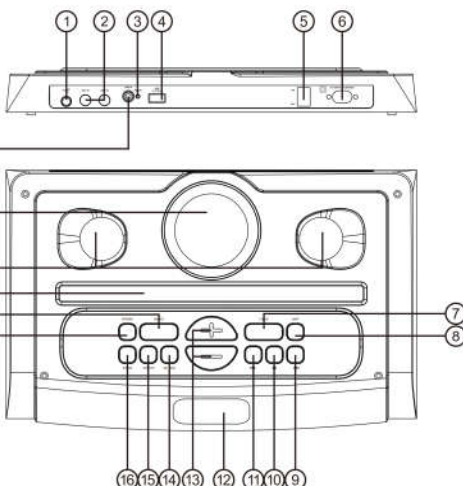



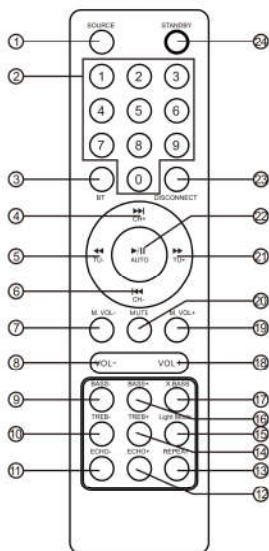

AFSTANDSBEDIENING

















- BRON**
Druk op om de bron te schakelen tussen USB, BT, FM, LIDN.
- 0 ~ 9 CIJFERTOETSEN**
Deze toetsen worden gebruikt om een nummer rechtstreeks in de USB-bronmodus af te spelen. Bijvoorbeeld: Om track 12 in de USB-afspeellijst af te spelen, drukt u op de cijfertoets "1" gevolgd door "2". Op FM, om het opgeslagen kanaal te selecteren of de zenderfrequentie rechtstreeks in te voeren
- BT**
Druk op om de Bluetooth-koppelingsmodus te openen.
- ▶▶/CH+**
In USB/BT-modus: Druk op om het volgende nummer af te spelen
In FM-modus: Druk hierop om naar het volgende opgeslagen kanaal te gaan
- ◀◀/IIJ-**
In USB/BT-modus: Druk hierop om het nummer terug te spoelen
In FM-modus: Druk op om de laagste radiofrequentie aan te passen
- ◀◀/CH-**
In USB/BT-modus: Druk op om het vorige nummer af te spelen
- MICROFOON VOL**
Leid het volume van de MIC af.
- VOL**
Verlaag het volume.
- BASSER-**
BASS Frequentie EQ Verminder BASS
- TREB-**
TREB Verlaag de TREBLE-frequentie-equalizer
- ECHO-**
Verminder het echo-effect
- ECHO +**
Verhoog het echo-effect
- REPEAT (alleen USB-modus)**
Druk op om de afspeelmodus te kiezen (Shuffle, Single, Repeat All)
- TREB+**
Verhoog de hoge frequentie-EQ
- LICHTE MODUS**
Verander de lichtmodus tussen LED1, LED2, LED3, LED4, UIT
- LAAG+**
Verhoog de EQ van de BASS-frequentie
- LAAG X**
Druk op deze toets om de extra basmodus in/uit te schakelen
- VOL+**
Zet het volume hoger.
- MIC VOL+**
Verhoog het microfoonvolume
- DEMPEN**
Druk op om de luidspreker MUTE/UNMUTE af te spelen
- ▶▶/IIJ-**
In USB/BT-modus: Druk op om het nummer snel vooruit te spoelen
In FM-modus: Druk op om de hoogste radiofrequentie in te stellen
- ▶▶/AUTOMATISCH**
In USB/BT-modus: afspelen/pauzeren
In FM-modus: Druk op om volledig automatisch naar radiofrequenties te zoeken.
- LOSKOPPELEN (BT-MODUS)**
Druk op om de verbinding te verbreken en te koppelen met een nieuw apparaat.
- STANDIG**
Druk hierop om de luidspreker in de stand-bymodus te zetten

In FM-modus: Druk op om naar het vorige opgeslagen kanaal te springen

BLUETOOTH-MODUS

<p>1</p>  <p>Zet de schakelaar in de AAN-stand</p>	<p>2</p>  <p>bt</p>  <p>Druk op de SOURCE-knop totdat "BT" op het scherm knippert.</p>	<p>3</p>  <p>Zoek naar GEMINI GSYS-T2115 in de Bluetooth-opties van uw mobiele apparaat</p>	<p>4</p> <p>bt</p>  <p>"BT" vastgemaakt aan het display. Succesvolle verbinding.</p>
---	--	--	---

TWS

<p>1</p> 	 <p>2</p> 	<p>2</p> 	
<p>1</p>  <p>Zet beide speakers aan</p>		 <p>bt</p>  <p>Druk op de SOURCE-knop op beide luidsprekers totdat ze naar de Bluetooth-modus gaan (op het scherm knippert "BT")</p>	
<p>3</p>  <p>ton</p> <p>Maintenez le bouton TWS enfoncé en "ton" s'affichera. Sur l'écran des deux Haut parleurs.</p>	 <p>ton</p>	<p>4</p>  <p>"beep"</p> <p>U hoort een "piep" op beide luidsprekers.</p>	 <p>"beep"</p>
		<p>5</p> <p>bt</p>  <p>Op een van de luidsprekers knippert nog steeds "BT" op het scherm, terwijl bij de andere "BT" vast staat.</p>	<p>bt</p> 
<p>6</p>  <p>Zoek naar GEMINI GSYS-T2115 in de Bluetooth-opties van uw mobiele apparaat</p>			

USB-MODUS

1



zet de schakelaar in de AAN-stand

2

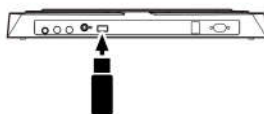

3



USB

Druk op de SOURCE-knop totdat "USB" op het scherm verschijnt

LINE IN-MODUS

1

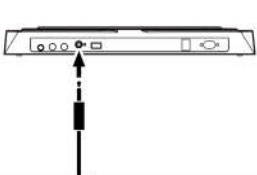

2



GELUID MIXEN MET MICROFOON

1

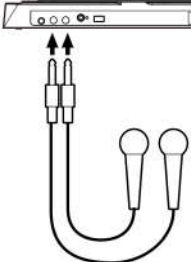

Sluit de dynamische microfoon aan op de 1/4"-ingang

2



2000

Om het microfoonvolume aan te passen, drukt u eenmaal op de MIC MENU-knop, op het display staat "2U***"

3

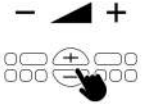

Gebruik de + en - knoppen om het microfoonvolume aan te passen

FCC Caution:

This device complies with part 15 of the FCC Rules. Operation is subject to the following two conditions: (1) this device may not cause harmful interference, and (2) this device must accept any interference received, including interference that may cause undesired operation.

Any changes or modifications not expressly approved by the party responsible for compliance could void the user's authority to operate the equipment.

NOTE: This equipment has been tested and found to comply with the limits for a Class B digital device, pursuant to Part 15 of the FCC Rules. These limits are designed to provide reasonable protection against harmful interference in a residential installation. This equipment generates, uses and can radiate radio frequency energy and, if not installed and used in accordance with the instructions, may cause harmful interference to radio communications. However, there is no guarantee that interference will not occur in a particular installation.

If this equipment does cause harmful interference to radio or television reception, which can be determined by turning the equipment off and on, the user is encouraged to try to correct the interference by one or more of the following measures:

- Reorient or relocate the receiving antenna.
- Increase the separation between the equipment and receiver.
- Connect the equipment into an outlet on a circuit different from that to which the receiver is connected.
- Consult the dealer or an experienced radio/TV technician for help.

To maintain compliance with FCC's RF Exposure guidelines, This equipment should be installed and operated with minimum distance between 20cm the radiator your body: Use only the supplied antenna.

gemini[®]

**If you experience problems with this unit,
call 732-346-0061 for Gemini customer service.
Do not attempt to return this equipment to your dealer.**

Parts of the design of this product may be protected by worldwide patents. Information in this manual is subject to change without notice and does not represent a commitment on the part of the vendor. Gemini shall not be liable for any loss or damage whatsoever arising from the use of information or any error contained in this manual. No part of this manual may be reproduced, stored in a retrieval system or transmitted, in any form or by any means, electronic, recommended that all maintenance and service on this product is performed by Gemini or its authorized agents. Gemini will not accept liability for loss or damage caused by maintenance or repair performed by unauthorized personnel.

WWW.GEMINISOUND.COM