

size:105x148mm

USER MANUAL

gemini[®]
GSYS-4800



148.00 mm

105.00 mm

CONTENTS

Product Introduction 3
Caution 3
Panel 4
Remote Control 5
Connection Diagram..... 6
Bluetooth Pair and Connect 7
USB 7
Line In 7
Mixing sound with microphone/guitar 8
FM Radio Operation 8
Specifications 8
Warranty information 9
Legality and Safety 10

148.00 mm

105.00 mm

Introduction

Thank you for purchasing our GSYS-4800 Complete High Power Speaker System. With proper care & maintenance, your unit will provide years of reliable, uninterrupted service. The GSYS-4800 is backed by a 1-year limited warranty*.

Preparing For First Use

Please ensure that you find these accessories included with your GSYS-4800 Series speaker:

- (2) *Speaker*
- (1) *Amplifier*
- (1) *Power cable*
- (1) *Operating Instructions*
- (1) *FM Antenna*
- (1) *Remote control*
- (1) *Wired Microphone*

Caution

- All operating instructions should be read before using this equipment.
- To reduce the risk of electrical shock, do not open the unit. There are no user replaceable parts inside.
- Please refer servicing to a qualified GEMINI service technician. Do not attempt to return this equipment to your dealer.
- Do not expose this unit to direct sunlight or to a heat source such as a radiator or stove.
- This unit should be cleaned only with a damp cloth. Avoid solvents or other cleaning detergents.
- When moving this equipment, it should be placed in its original carton and packaging. This will reduce the risk of damage during transit.
- Do not expose this unit to water or heat.
- Do not use cleaning products or lubricants on the controls or switches.

Precautions

Please read carefully before proceeding

Always follow the basic precautions listed below to avoid the possibility of serious injury or even death from electrical shock, short-circuiting, damages, fire, or other hazards.

- *Read Instructions:* All the safety and operating instructions should be read before the product is operated.
- *Retain Instructions:* The safety and operating instructions should be retained for future reference. All the safety and operating instructions should be read before the product is operated.
- *Heed Warnings:* All warnings on the product and in the operating instructions should be adhered to.
- *Follow Instructions:* All operating and use instructions should be followed.
- *Cleaning:* The product should be cleaned only with a polishing cloth or a soft dry cloth. Never clean with furniture wax, benzene, insecticides or other volatile liquids since they may corrode the cabinet.
- *Water And Moisture:* Do not use this product near water, for example, near a bathtub, wash bowl, kitchen sink, or Laundry tub; in a wet basement; or near a swimming pool; and the like.
- *Do Not Open:* Do not open the device or attempt to disassemble the internal parts or modify them in any way. The device contains no user- serviceable parts. If it should appear to be malfunctioning, discontinue use immediately and have it inspected by qualified GEMINI service personnel.
- *Replacement Parts:* When replacement parts are required, be sure the service technician has used replacement parts specified by the manufacturer or have the same characteristics as the original part. Unauthorized substitutions may result in fire, electric shock, or other hazards.
- *Location:* Before moving the device, remove all connected cables.
 - Do not use the speaker's handles for suspended installation. Doing so can result in damage or injury.
 - Do not expose the device to excessive dust or vibrations, or extreme cold or heat (such as in direct sunlight, near a heater) to prevent the possibility of panel disfiguration or damage to the internal components.
 - Do not place the device in an unstable position where it may accidentally fall over.
- *Connections:* Before connecting the device to other devices, turn off the power for all devices. Before turning the power on or off for all devices, set all volume levels to minimum.

148.00 mm

105.00 mm

Panel

1. POWER SWITCH: Press this switch to turn the unit ON or OFF

2. STANDBY: Press to Standby, ON, and OFF.

3. SOURCE: Press this key to change the sources between USB, BT, FM, LINE.

4. LINE-IN: Line-in input socket

5. POWER LIGHT

6. USB: USB input socket

Important: The USB port is intended only for data transfer only; other devices cannot be used with this USB connection. The use of USB extension cords is not recommended.

7. X.DRIVE: Press the key to turn the extra bass effect ON/OFF.

8. -/+ : To adjust the levels.

9. MIC IN: Wired Mic input socket

10. GUITAR IN: Guitar input socket

11. EFFECTS: Press this key to change the menu between MIC, GUITAR, VOLUME, ECHO VOLUME, BASS, TREBLE.

12. LIGHT : Press to LIGHT, ON, and OFF.

13. LED DISPLAY: To display speaker status.

14. ►►: To play the next song at USB/BT input mode.

15. ►||: In USB/BT input mode: Press to PLAY/PAUSE a track.

16. ◀◀: To play the previous song at USB/BT input mode.

17. FM Antenna

18. SPEAKER OUTPUT JACK

19. AC INPUT : AC 100V-240V~,50/60Hz.

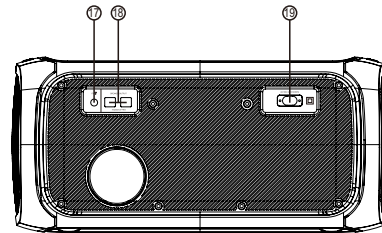
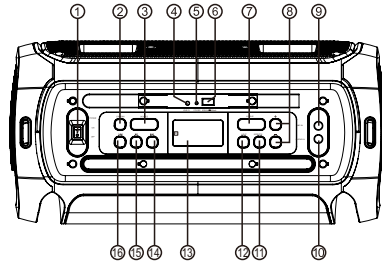

Remote Control

1. **STANDBY** : Standby ON/OFF .
2. **0-9 NUMERIC KEYS**: These keys are used to play a track directly in USB source mode.
Eg:-To play 12th track in the USB playlist press the numeric key"1" followed by"2".
3. **VOL-** : To decrease the volume.
4. **◀◀/CH-** : Play the previous song by pressing "◀◀/CH-" in USB/BT input mode.
Choose previous channel by pressing "◀◀/CH-" in FM input mode.
5. **▶▶**: Play / pause in USB/BT mode. In FM mode press for full automatic search.
6. **◀◀/TU-** : Fast rewind a song by pressing "◀◀/TU-" in USB input mode.
Choose tuning channel by pressing "◀◀/TU-" in FM input mode.
7. **▶▶/TU+** : Fast forward song by pressing "▶▶/TU+" in USB input mode.
Choose tuning channel by pressing "▶▶/TU+" in FM input mode.
8. **▶▶/CH+** : Play the next song by pressing "▶▶/CH+" in USB/BT input mode.
Choose next channel by pressing "▶▶/CH+" in FM input mode.
9. **VOL+** : To increase the volume.
10. **MUTE** : Press to switch mute ON/OFF.
11. **EQUALIZER**
12. **SOURCE** : Press to change the source between BT, LINE, FM, USB.

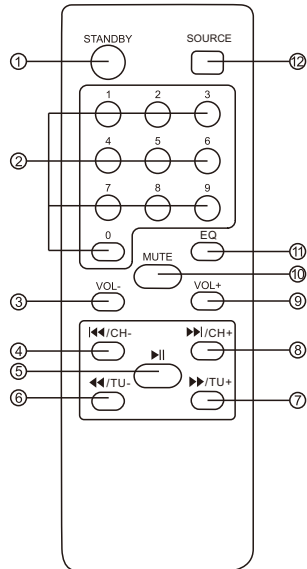

CONNECTION DIAGRAM:

Note:

- Always unplug the unit when making connections.
- Check all connections are firmly fitted.
- Check all speakers are connected to their correct designated position.

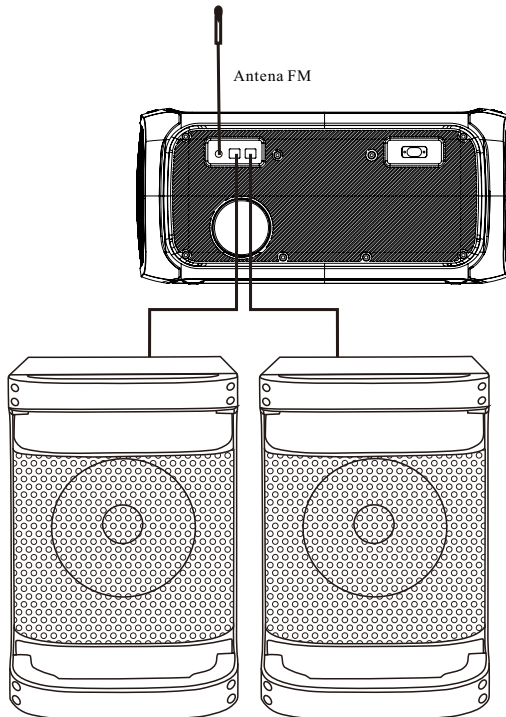

Bluetooth

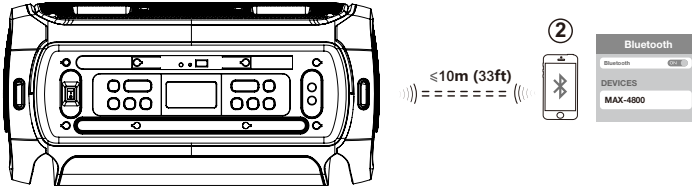

USB

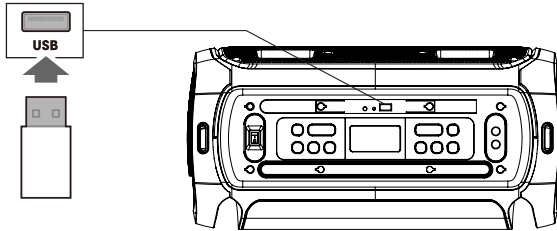

LINE IN

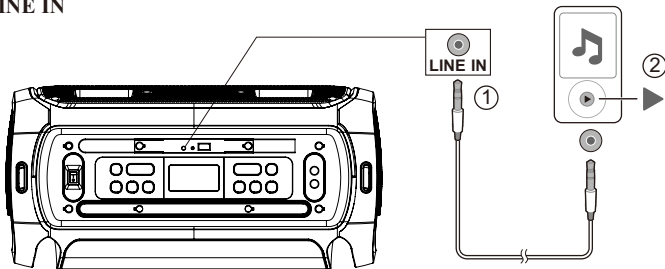

Mixing sound with microphone/guitar (not provided)

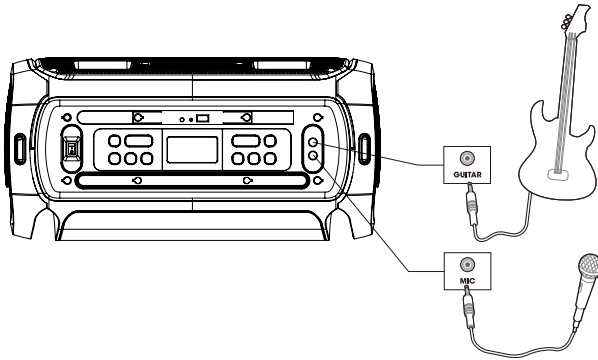

FM Radio Operation

1. Before using the radio functions, you must attach the supplied antenna. Adjust the antenna to obtain optimum reception.
 2. Press [SOURCE] to select FM mode.
 3. Press the CH+/CH- key on the remote control or Hold the [◀▶▶▶] key to skip to the preset station.
 4. Press the TU+/TU- key on the remote control or press the [◀▶▶▶] key on the top panel to adjust the radio frequency manually.
(The number key on the remote control can directly select the frequency. Such as enter "8,8,1" keys for 88.1MHz, "1,0,4,0" keys for 104.0MHz.)
- Press the PLAY key on the remote control or Press the [▶||] key on the top panel, the machine will scan radio channels from low-frequency to high-frequency by itself and memorize the channels one by one.

Specifications

Frequency Response	30Hz-20KHz
Power Source	100-240V~,50/60Hz
Power Consumption	~180W

Due to continuous product development specifications and functions may be changed without prior notice.

Warranty and Repair

All Gemini products are designed and manufactured to the highest standards in the industry. With proper care and maintenance, your product will provide years of reliable service.

Limited Warranty

a. GEMINI guarantees its products to be free from defects in materials and workmanship for one (1) year from the original purchase date.

b. This limited warranty does not cover damage or failure caused by abuse, misuse, abnormal use, faulty installation, improper maintenance or any repairs other than those provided by an authorized Gemini Service Center

c. There are no obligations of liability on the part of GEMINI for consequential damages arising out of or in connection with the use or performance of the product or other indirect damages with respect to loss of property, revenues, of profit, or costs of removal, installation, or reinstallation. All implied warranties for GEMINI, including implied warranties for fitness, are limited in duration to one (1) year from the original date of purchase, unless otherwise mandated by local statutes.

Return/Repair

a. Please call our helpful Customer Service Representatives at 732-346-0061, and they will be happy to give you a Return Authorization Number (RMA) and the address of an authorized service center closest to you.

b. After receiving an RMA, include a copy of the original sales receipt, with defective product and a description of the defect. Send by insured freight to: Gemini and use the address provided by your customer service representative. Your RMA must be written on the outside of the package, or processing will be delayed indefinitely!

c. Service covered under warranty will be paid for by Gemini and returned to you. For non-warrantied products, Gemini will repair your unit after payment is received. Repair charges do not include return freight. Freight charges will be added to the repair charges.

d. On warranty service, you pay for shipping to Gemini, we pay for return shipping within the continental United States. Alaska, Hawaii, Puerto Rico, Canada, Bahamas, and the Virgin Islands will be charged for freight.

e. Please allow 2-3 weeks for return of your product. Under normal circumstances your product will spend no more than 10 working days at Gemini. We are not responsible for shipping times.

LEGALITY & SAFETY

The device is not intended for use by people (including children) with reduced physical, sensory or mental capacity. People who have not read the manual, unless they have received an explanation by someone responsible for their safety, should not use this unit. Children should be monitored to ensure that they do not play with the device. The device should always be readily accessible. The device should not be exposed to water. No objects filled with liquids, such as vases, shall be placed on the device. Always leave a minimum distance of 10 cm around the unit to ensure sufficient ventilation. Open flame sources, such as candles, should not be placed on top of the device. The device is intended for use only in a temperate climate. At full volume, prolonged listening may damage your hearing and cause temporary or permanent deafness, hearing drone, tinnitus, or hyperacusis. Listening at high volume is not recommended. One hour per day is not recommended either. Switch the device off where the use of the device is not allowed or where there is a risk of causing interference or danger - for examples: on an aircraft, or near medical equipment, fuel, chemicals or blasting sites. Check the current laws and regulations regarding the use of this device in the areas where you drive. Do not handle the device when driving. Concentrate fully on driving. All wireless devices are susceptible to interference which may affect their performance. All our devices conform to international/national standards and regulations, and we aim to limit user exposure to electromagnetic fields. These standards and regulations were adopted after the completion of extensive scientific research. This research established no link between the use of the mobile headset and any adverse effects on health if the device is used in accordance with standard practices. Only qualified people are authorized to install or repair this product. Only use batteries, chargers and other accessories which are compatible with this equipment. Do not connect incompatible products. This equipment is not waterproof. Keep it dry. Keep your device in a safe place, out of the reach of young children. The device contains small parts which may present a choking hazard to kids.

FCC Caution:

This device complies with part 15 of the FCC Rules. Operation is subject to the following two conditions: (1) this device may not cause harmful interference, and (2) this device must accept any interference received, including interference that may cause undesired operation.

Any changes or modifications not expressly approved by the party responsible for compliance could void the user's authority to operate the equipment.

NOTE: This equipment has been tested and found to comply with the limits for a Class B digital device, pursuant to Part 15 of the FCC Rules. These limits are designed to provide reasonable protection against harmful interference in a residential installation. This equipment generates, uses and can radiate radio frequency energy and, if not installed and used in accordance with the instructions, may cause harmful interference to radio communications. However, there is no guarantee that interference will not occur in a particular installation. If this equipment does cause harmful interference to radio or television reception, which can be determined by turning the equipment off and on, the user is encouraged to try to correct the interference by one or more of the following measures:

- Reorient or relocate the receiving antenna.
- Increase the separation between the equipment and receiver.
- Connect the equipment into an outlet on a circuit different from that to which the receiver is connected.
- Consult the dealer or an experienced radio/TV technician for help.

To maintain compliance with FCC's RF Exposure guidelines, This equipment should be installed and operated with minimum distance between 20cm the radiator your body: Use only the supplied antenna.