



FCC TEST REPORT

**Test report
On Behalf of
INNOVATIVE CONCEPTS AND DESIGN LLC
For
Bamboo speaker**

Model No.: BRS-130,BRS-230,BRS-330,BRS-430

FCC ID: 2AE6G-BRS130

Prepared for : INNOVATIVE CONCEPTS AND DESIGN LLC
107 Trumbull Street – Bldg. F8,Elizabeth, NJ 07206 USA

Prepared By : Shenzhen HUAK Testing Technology Co., Ltd.
1F, B2 Building, Junfeng Zhongcheng Zhizao Innovation Park, Fuhai Street,
Bao'an District, Shenzhen City, China

Date of Test: Jun. 27, 2018 ~ Jul. 16, 2018

Date of Report: Jul. 16, 2018

Report Number: HK1904300959-E



TEST RESULT CERTIFICATION

Applicant's name : INNOVATIVE CONCEPTS AND DESIGN LLC
 Address : 107 Trumbull Street – Bldg. F8,Elizabeth, NJ 07206 USA
Manufacture's Name..... : CHRIS TECHNOLOGY CO.,LTD
 Address : Honghualing Industrial Zone 1,Yuhu Village Longgang Distrst,
 shenzhen,china

Product description

Trade Mark: GEMINI
 Product name..... : Bamboo speaker
 Model and/or type reference : BRS-130,BRS-230,BRS-330,BRS-430

Standards..... : FCC Rules and Regulations Part 15 Subpart C Section 15.249
 ANSI C63.10: 2013

This publication may be reproduced in whole or in part for non-commercial purposes as long as the Shenzhen HUAKE Testing Technology Co., Ltd. is acknowledged as copyright owner and source of the material. Shenzhen HUAKE Testing Technology Co., Ltd. takes no responsibility for and will not assume liability for damages resulting from the reader's interpretation of the reproduced material due to its placement and context.

Date of Test..... :
 Date (s) of performance of tests..... : **Apr. 29, 2019~ Jun. 12, 2019**
 Date of Issue..... : **Jun. 12, 2019**
 Test Result..... : **Pass**

Testing Engineer : Gary Qian
 (Gary Qian)

Technical Manager : Eden Hu
 (Eden Hu)

Authorized Signatory : Jason Zhou
 (Jason Zhou)



Table of Contents	Page
1 . TEST SUMMARY	4
2 . GENERAL INFORMATION	5
2.1 GENERAL DESCRIPTION OF EUT	5
2.2 Operation of EUT during testing	6
2.3 DESCRIPTION OF TEST SETUP	7
2.4 MEASUREMENT INSTRUMENTS LIST	8
3 . CONDUCTED EMISSIONS TEST	9
3.1 Conducted Power Line Emission Limit	9
3.2 Test Setup	9
3.3 Test Procedure	9
3.4 Test Result	9
4 RADIATED EMISSION TEST	12
4.1 Radiation Limit	12
4.2 Test Setup	12
4.3 Test Procedure	13
4.4 Test Result	13
5 BAND EDGE	20
5.1 Limits	20
5.2 Test Procedure	20
5.3 Test Result	20
6 OCCUPIED BANDWIDTH MEASUREMENT	25
6.1 Test Setup	25
6.2 Test Procedure	25
6.3 Measurement Equipment Used	25
6.4 Test Result	25
7 ANTENNA REQUIREMENT	31
8 PHOTOGRAPH OF TEST	32
8.1 Radiated Emission	32
8.2 Conducted Emission	33



1. TEST SUMMARY

1.1 TEST PROCEDURES AND RESULTS

DESCRIPTION OF TEST	RESULT
CONDUCTED EMISSIONS TEST	COMPLIANT
RADIATED EMISSION TEST	COMPLIANT
BAND EDGE	COMPLIANT
OCCUPIED BANDWIDTH MEASUREMENT	COMPLIANT
ANTENNA REQUIREMENT	COMPLIANT

1.2 TEST FACILITY

Test Firm : Shenzhen HUAK Testing Technology Co., Ltd.

Address : 1F, B2 Building, Junfeng Zhongcheng Zhizao Innovation Park, Fuhai Street, Bao'an District, Shenzhen City, China

1.3 MEASUREMENT UNCERTAINTY

Measurement Uncertainty	
Conducted Emission Expanded Uncertainty	= 2.23dB, k=2
Radiated emission expanded uncertainty(9kHz-30MHz)	= 3.08dB, k=2
Radiated emission expanded uncertainty(30MHz-1000MHz)	= 4.42dB, k=2
Radiated emission expanded uncertainty(Above 1GHz)	= 4.06dB, k=2



2. GENERAL INFORMATION

2.1 GENERAL DESCRIPTION OF EUT

Equipment	Bamboo speaker
Model Name	BRS-130
Serial No	BRS-230,BRS-330,BRS-430
Model Difference	All models are identical except model name.
Antenna Type	PCB onboard antenna
Antenna Gain	0 dBi
BT Operation frequency	2402-2480MHz
Number of Channels	79CH
Modulation Type	GFSK, $\pi/4$ DQPSK, 8DPSK
Power Source	DC7.4V From Battery or DC 5V from adapter with AC 120V/60Hz
Power Rating	DC7.4V From Battery or DC 5V from adapter with AC 120V/60Hz



2.1.1 Carrier Frequency of Channels

Channel List					
Channel	Frequency (MHz)	Channel	Frequency (MHz)	Channel	Frequency (MHz)
00	2402	27	2429	54	2456
01	2403	28	2430	55	2457
02	2404	29	2431	56	2458
03	2405	30	2432	57	2459
04	2406	31	2433	58	2460
05	2407	32	2434	59	2461
06	2408	33	2435	60	2462
07	2409	34	2436	61	2463
08	2410	35	2437	62	2464
09	2411	36	2438	63	2465
10	2412	37	2439	64	2466
11	2413	38	2440	65	2467
12	2414	39	2441	66	2468
13	2415	40	2442	67	2469
14	2416	41	2443	68	2470
15	2417	42	2444	69	2471
16	2418	43	2445	70	2472
17	2419	44	2446	71	2473
18	2420	45	2447	72	2474
19	2421	46	2448	73	2475
20	2422	47	2449	74	2476
21	2423	48	2450	75	2477
22	2424	49	2451	76	2478
23	2425	50	2452	77	2479
24	2426	51	2453	78	2480
25	2427	52	2454		
26	2428	53	2455		

2.2 Operation of EUT during testing

Operating Mode

Preliminary tests were performed in each mode and packet length of BT, and found worst case as bellow, finally test were conducted at those mode and recorded in this report.

Test Items	Worst case
CONDUCTED EMISSIONS TEST	DH5 Middle channel
RADIATED EMISSION TEST	DH5 Middle channel
BAND EDGE	DH5
OCCUPIED BANDWIDTH MEASUREMENT	DH5/2DH5/3DH5
ANTENNA REQUIREMENT	DH5/2DH5/3DH5 Middle channel

The mode is used: **Transmitting mode**

Low Channel: 2402MHz

Middle Channel: 2441MHz

High Channel: 2480MHz



2.3 DESCRIPTION OF TEST SETUP

Operation of EUT during Conducted testing:

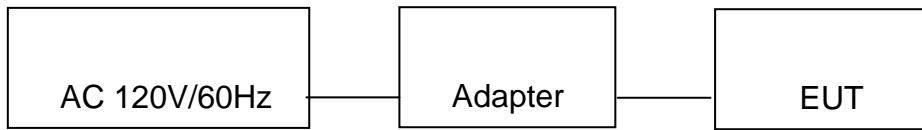

Operation of EUT during Radiation and Above1GHz Radiation testing:



● Adapter

Model: PL0652

Input: 100-240V~, 50/60Hz, 0.5A

Output: 5VDC, 1A



2.4 MEASUREMENT INSTRUMENTS LIST

Item	Equipment	Manufacturer	Model No.	Serial No.	Last Cal.	Cal. Interval
1.	L.I.S.N. Artificial Mains Network	R&S	ENV216	HKE-002	Dec. 28, 2018	1 Year
2.	Receiver	R&S	ESCI 7	HKE-010	Dec. 28, 2018	1 Year
3.	RF automatic control unit	Tonscend	JS0806-2	HKE-060	Dec. 28, 2018	1 Year
4.	Spectrum analyzer	R&S	FSP40	HKE-025	Dec. 28, 2018	1 Year
5.	Spectrum analyzer	Agilent	N9020A	HKE-048	Dec. 28, 2018	1 Year
6.	Preamplifier	Schwarzbeck	BBV 9743	HKE-006	Dec. 28, 2018	1 Year
7.	EMI Test Receiver	Rohde & Schwarz	ESCI 7	HKE-010	Dec. 28, 2018	1 Year
8.	Bilog Broadband Antenna	Schwarzbeck	VULB9163	HKE-012	Dec. 28, 2018	1 Year
9.	Loop Antenna	Schwarzbeck	FMZB 1519 B	HKE-014	Dec. 28, 2018	1 Year
10.	Horn Antenna	Schwarzbeck	9120D	HKE-013	Dec. 28, 2018	1 Year
11.	Pre-amplifier	EMCI	EMC051845 SE	HKE-015	Dec. 28, 2018	1 Year
12.	Pre-amplifier	Agilent	83051A	HKE-016	Dec. 28, 2018	1 Year
13.	EMI Test Software EZ-EMC	Tonscend	JS1120-B Version	HKE-083	Dec. 28, 2018	N/A
14.	Power Sensor	Agilent	E9300A	HKE-086	Dec. 28, 2018	1 Year
15.	Spectrum analyzer	Agilent	N9020A	HKE-048	Dec. 28, 2018	1 Year
16.	Signal generator	Agilent	N5182A	HKE-029	Dec. 28, 2018	1 Year
17.	Signal Generator	Agilent	83630A	HKE-028	Dec. 28, 2018	1 Year
18.	Shielded room	Shiel Hong	4*3*3	HKE-039	Dec. 28, 2018	3 Year



3. CONDUCTED EMISSIONS TEST

3.1 Conducted Power Line Emission Limit

For unintentional device, according to § 15.107(a) Line Conducted Emission Limits is as following

Frequency (MHz)	Maximum RF Line Voltage (dBµV)			
	CLASS A		CLASS B	
	Q.P.	Ave.	Q.P.	Ave.
0.15 - 0.50	79	66	66-56*	56-46*
0.50 - 5.00	73	60	56	46
5.00 - 30.0	73	60	60	50

* Decreasing linearly with the logarithm of the frequency

For intentional device, according to §15.207(a) Line Conducted Emission Limit is same as above table.

3.2 Test Setup

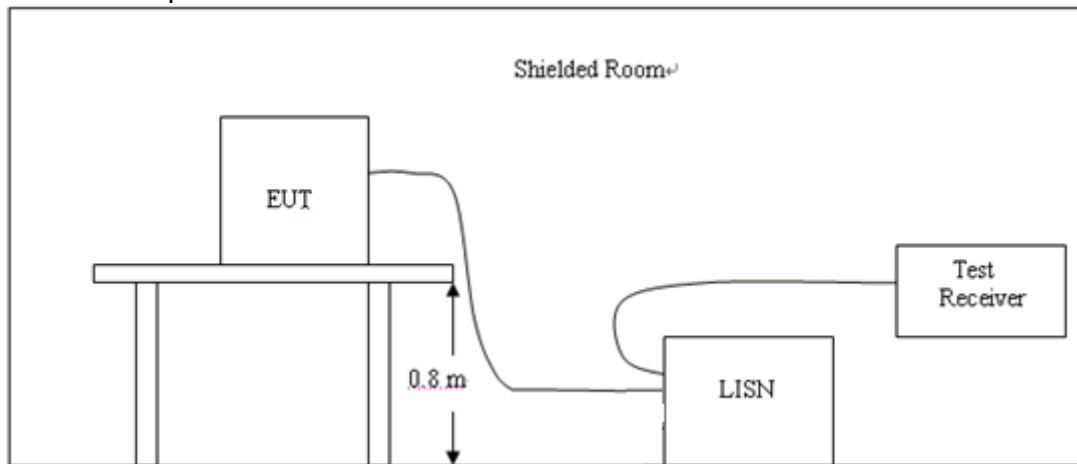

3.3 Test Procedure

- 1, The equipment was set up as per the test configuration to simulate typical actual usage per the user's manual. The EUT is a tabletop system, a wooden table with a height of 0.1 meters is used and is placed on the ground plane as per ANSI C63.10.
- 2, Support equipment, if needed, was placed as per ANSI C63.10.
- 3, All I/O cables were positioned to simulate typical actual usage as per ANSI C63.10.
- 4, If a EUT received DC power from the USB Port of Notebook PC, the PC's adapter received AC120V/60Hz power through a Line Impedance Stabilization Network (LISN) which supplied power source and was grounded to the ground plane.
- 5, All support equipments received AC power from a second LISN, if any.
- 6, The EUT test program was started. Emissions were measured on each current carrying line of the EUT using a spectrum Analyzer / Receiver connected to the LISN powering the EUT. The LISN has two monitoring points: Line 1 (Hot Side) and Line 2 (Neutral Side). Two scans were taken: one with Line 1 connected to Analyzer / Receiver and Line 2 connected to a 50 ohm load; the second scan had Line 1 connected to a 50 ohm load and Line 2 connected to the Analyzer / Receiver.
- 7, Analyzer / Receiver scanned from 150 KHz to 30MHz for emissions in each of the test modes.

3.4 Test Result

PASS

All the test modes completed for test.



EUT :	Bamboo speaker	Model Name. :	BRS-130
Temperature :	26 °C	Relative Humidity :	54%
Pressure :	1010hPa	Test Date :	2019-06-06
Test Mode :	BT	Phase :	L
Test Voltage :	DC 5V by Adapter AC 120V/60Hz		

Test Graph

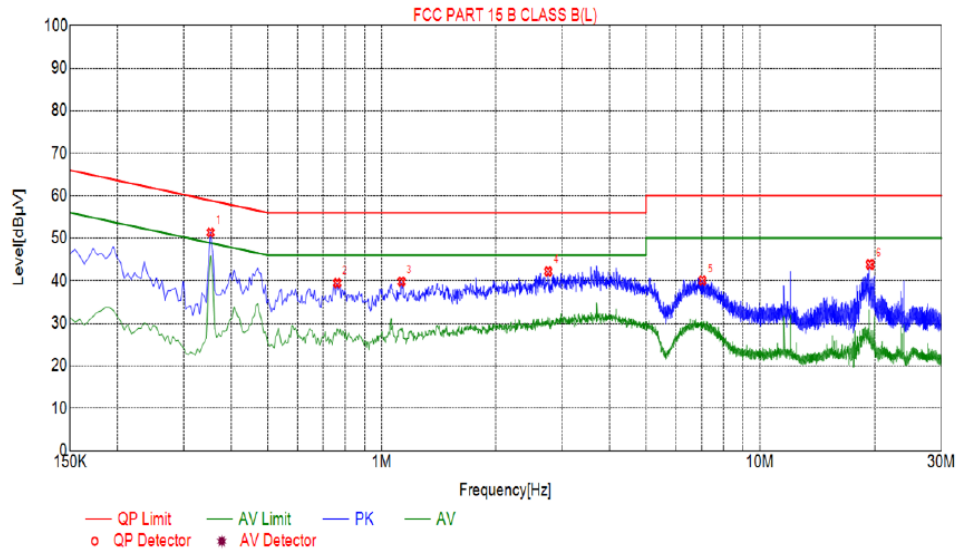

Suspected List						
NO.	Freq. [MHz]	Level [dBµV]	Factor [dB]	Limit [dBµV]	Margin [dB]	Detector
1	0.3525	51.35	10.03	58.90	7.55	PK
2	0.7620	39.47	10.05	56.00	16.53	PK
3	1.1265	39.80	10.08	56.00	16.20	PK
4	2.7555	42.20	10.21	56.00	13.80	PK
5	7.0440	40.07	10.20	60.00	19.93	PK
6	19.5000	43.83	10.08	60.00	16.17	PK



EUT :	Bamboo speaker	Model Name. :	BRS-130
Temperature :	26 °C	Relative Humidity :	54%
Pressure :	1010hPa	Test Date :	2019-06-06
Test Mode :	BT	Phase :	N
Test Voltage :	DC 5V by Adapter AC 120V/60Hz		

Test Graph

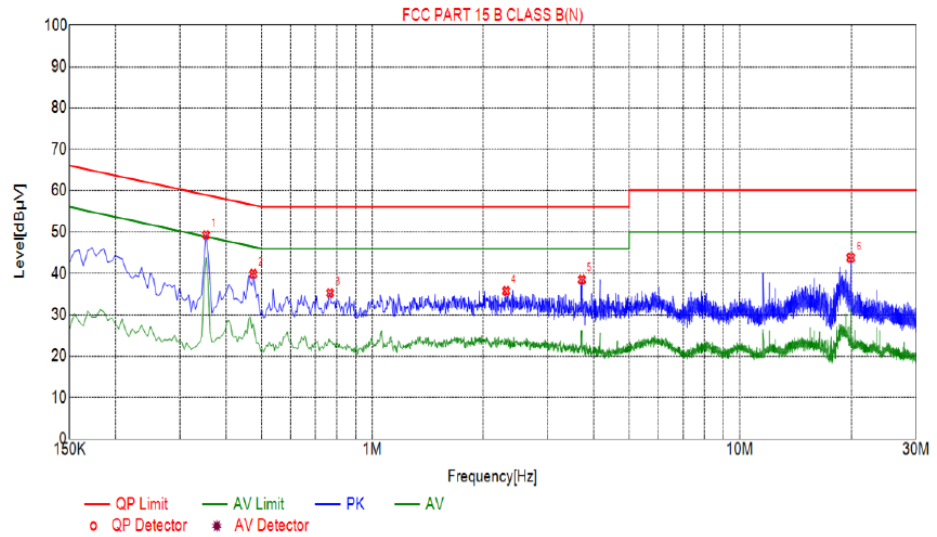

Suspected List						
NO.	Freq. [MHz]	Level [dBµV]	Factor [dB]	Limit [dBµV]	Margin [dB]	Detector
1	0.3525	49.33	10.03	58.90	9.57	PK
2	0.4740	39.94	10.04	56.44	16.50	PK
3	0.7665	35.30	10.05	56.00	20.70	PK
4	2.3145	35.81	10.18	56.00	20.19	PK
5	3.7185	38.55	10.25	56.00	17.45	PK
6	19.9635	43.81	10.10	60.00	16.19	PK

4 RADIATED EMISSION TEST

4.1 Radiation Limit

For unintentional device, according to § 15.109(a), except for Class A digital devices, the field strength of radiated emissions from unintentional radiators at a distance of 3 meters shall not exceed the following values:

Frequency (MHz)	Distance (Meters)	Radiated (dBµV/m)	Radiated (µV/m)
0.009-0.49	3	$20\log(2400/F(\text{KHz}))+40\log(300/3)$	$2400/F(\text{KHz})$
0.49-1.705	3	$20\log(24000/F(\text{KHz}))+40\log(30/3)$	$24000/F(\text{KHz})$
1.705-30	3	$20\log(30)+40\log(30/3)$	30
30-88	3	40.0	100
88-216	3	43.5	150
216-960	3	46.0	200
Above 960	3	54.0	500

For intentional device, according to § 15.209(a), the general requirement of field strength of radiated emissions from intentional radiators at a distance of 3 meters shall not exceed the above table.

4.2 Test Setup

(1) Radiated Emission Test-Up Frequency Below 30MHz

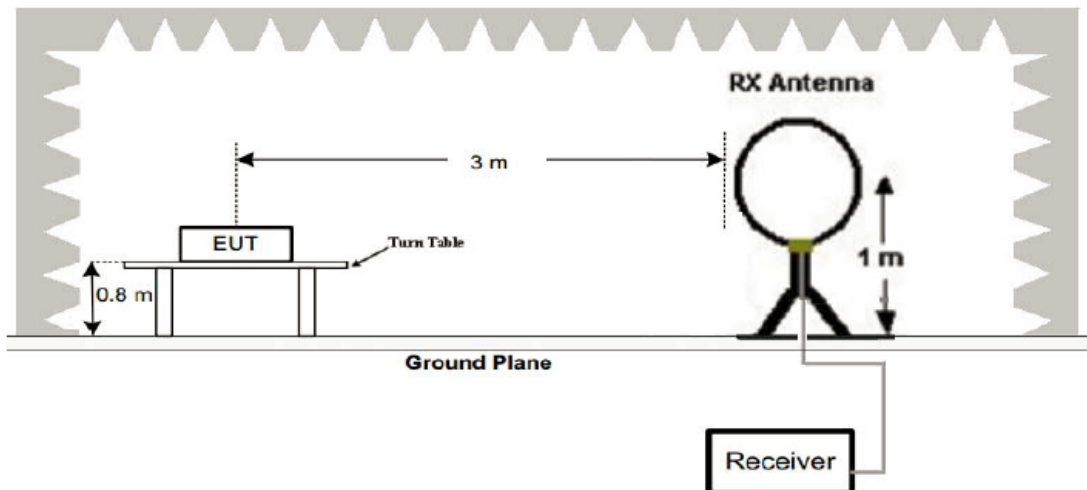

(2) Radiated Emission Test-Up Frequency 30MHz~1GHz

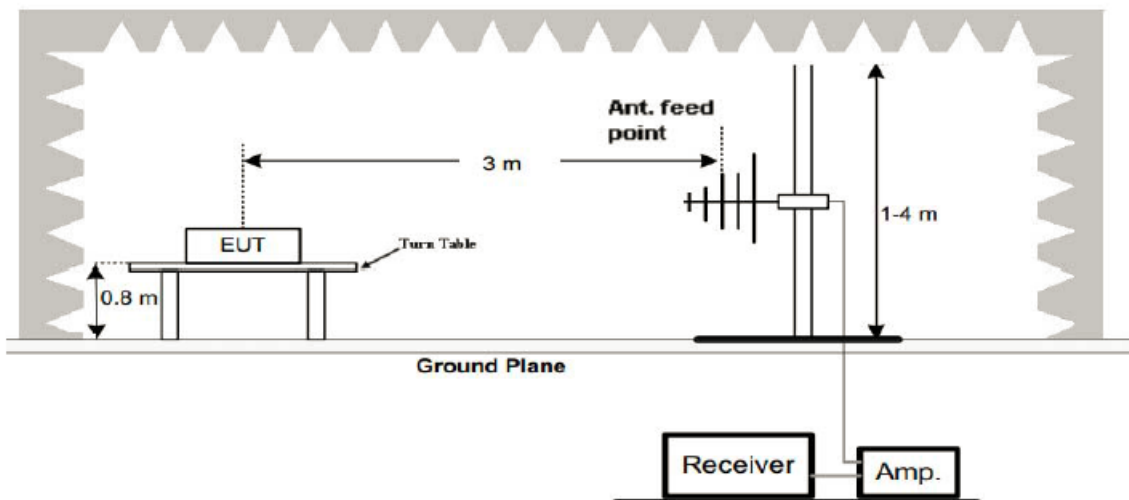

(3) Radiated Emission Test-Up Frequency Above 1GHz

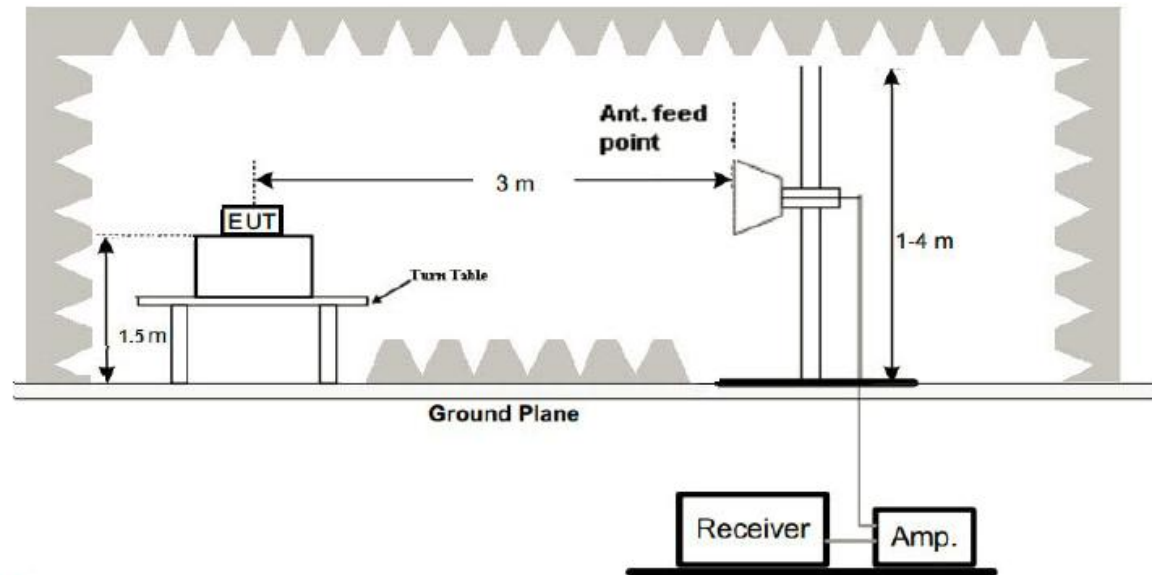

4.3 Test Procedure

1. Below 1GHz measurement the EUT is placed on turntable which is 0.1m above ground plane. And above 1GHz measurement EUT was placed on low permittivity and low tangent turn table which is 0.1m above ground plane.
2. The turntable shall be rotated for 360 degrees to determine the position of maximum emission level.
3. EUT is set 3m away from the receiving antenna, which is varied from 1m to 4m to find out the highest emissions.
4. Maximum procedure was performed on the six highest emissions to ensure EUT compliance.
5. And also, each emission was to be maximized by changing the polarization of receiving antenna both horizontal and vertical.
6. Repeat above procedures until the measurements for all frequencies are complete.
7. The test frequency range from 9KHz to 25GHz per FCC PART 15.33(a).

Note:

For battery operated equipment, the equipment tests shall be performed using a new battery.

4.4 Test Result

PASS

All the test modes completed for test. The worst case of Radiated Emission is CH 2441; the test data of this mode was reported.



Below 1GHz Test Results:

EUT :	Bamboo speaker	Model Name :	BRS-130
Temperature :	24 °C	Relative Humidity :	54%
Pressure :	1010 hPa	Test Date :	2019-06-06
Test Mode :	BT	Polarization :	Horizontal
Test Power :	DC 5V by Adapter AC 120V/60Hz		

Test Graph

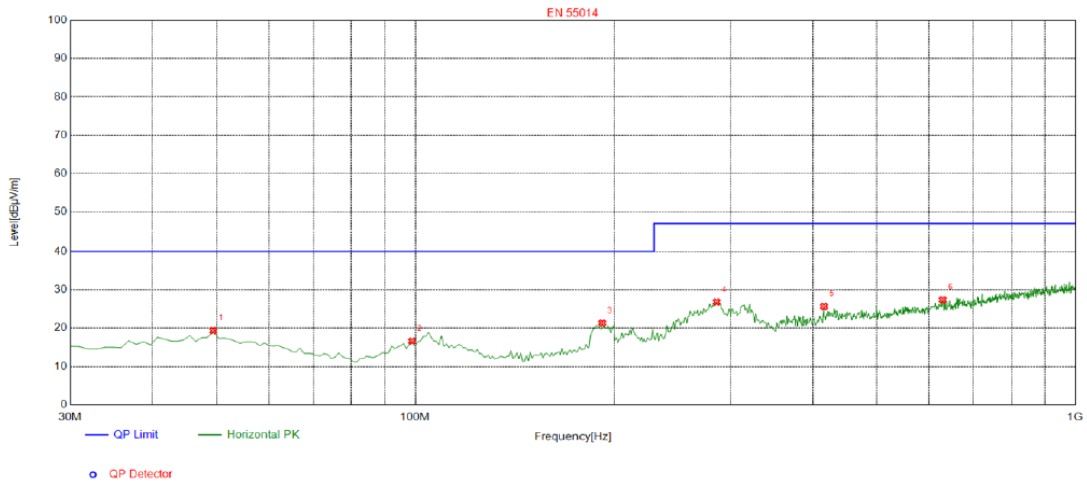

Suspected List

Suspected List								
NO.	Freq. [MHz]	Level [dBµV/m]	Factor [dB]	Limit [dBµV/m]	Margin [dB]	Height [cm]	Angle [°]	Polarity
1	49.4000	19.33	-13.65	40.00	20.67	100	182	Horizontal
2	98.8700	16.61	-15.59	40.00	23.39	100	191	Horizontal
3	191.990	21.32	-15.82	40.00	18.68	100	271	Horizontal
4	286.080	26.80	-13.00	47.00	20.20	100	43	Horizontal
5	416.060	25.66	-10.11	47.00	21.34	100	326	Horizontal
6	629.460	27.39	-5.48	47.00	19.61	100	60	Horizontal

Final Data List



EUT :	Bamboo speaker	Model Name :	BRS-130
Temperature :	24 °C	Relative Humidity :	54%
Pressure :	1010 hPa	Test Date :	2019-06-06
Test Mode :	On	Polarization :	Vertical
Test Power :	DC 5V by Adapter AC 120V/60Hz		

Test Graph

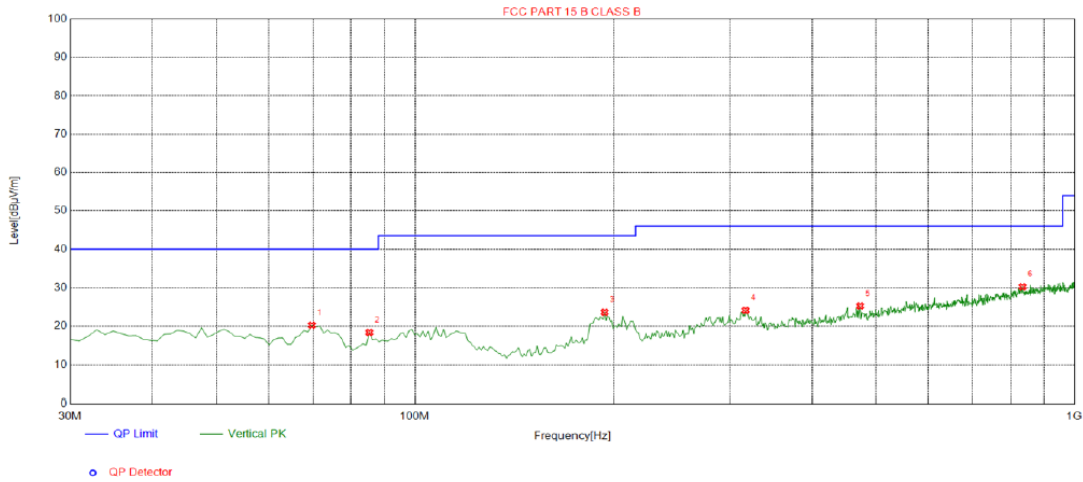

Suspected List

Suspected List								
NO.	Freq. [MHz]	Level [dBµV/m]	Factor [dB]	Limit [dBµV/m]	Margin [dB]	Height [cm]	Angle [°]	Polarity
1	69.7700	20.25	-17.61	40.00	19.75	100	173	Vertical
2	85.2900	18.38	-18.20	40.00	21.62	100	119	Vertical
3	193.930	23.64	-15.64	43.50	19.86	100	114	Vertical
4	317.120	24.15	-12.25	46.00	21.85	100	357	Vertical
5	473.290	25.28	-8.37	46.00	20.72	100	51	Vertical
6	834.130	30.29	-2.49	46.00	15.71	100	269	Vertical

Final Data List

Remark:

- (1) Measuring frequencies from 9 KHz to the 1 GHz, Radiated emission test from 9KHz to 30MHz was verified, and no any emission was found except system noise floor.
- (2) * denotes emission frequency which appearing within the Restricted Bands specified in provision of 15.205, then the general radiated emission limits in 15.209 apply.
- (3) The IF bandwidth of EMI Test Receiver between 30MHz to 1GHz was 120KHz, 1 MHz for measuring above 1 GHz, below 30MHz was 10KHz.



Above 1 GHz Test Results:

CH Low (2402MHz)

Horizontal:

Frequency	Reading Result	Factor	Emission Level	Limits	Margin	Detector Type
(MHz)	(dBuV)	(dB)	(dBuV/m)	(dBuV/m)	(dB)	
2402	106.35	-5.84	100.51	114	-13.49	Peak
2402	82.69	-5.84	76.85	94	-17.15	AVG
4804	62.13	-3.64	58.49	74	-15.51	Peak
4804	43.78	-3.64	40.14	54	-13.86	AVG
7206	59.72	-0.95	58.77	74	-15.23	Peak
7206	41.08	-0.95	40.13	54	-13.87	AVG

Remark:Factor=Antenna Factor+Cable Loss-Pre-amplifier

Vertical:

Frequency	Reading Result	Factor	Emission Level	Limits	Margin	Detector Type
(MHz)	(dBuV)	(dB)	(dBuV/m)	(dBuV/m)	(dB)	
2402	104.28	-5.84	98.44	114	-15.56	Peak
2402	81.96	-5.84	76.12	94	-17.88	AVG
4804	59.72	-3.64	56.08	74	-17.92	Peak
4804	42.16	-3.64	38.52	54	-15.48	AVG
7206	60.28	-0.95	59.33	74	-14.67	Peak
7206	40.37	-0.95	39.42	54	-14.58	AVG

Remark:Factor=Antenna Factor+Cable Loss-Pre-amplifier



CH Middle (2441MHz)

Horizontal:

Frequency	Reading Result	Factor	Emission Level	Limits	Margin	Detector Type
(MHz)	(dBuV)	(dB)	(dBuV/m)	(dBuV/m)	(dB)	
2441	106.25	-5.71	100.54	114	-13.46	Peak
2441	83.41	-5.71	77.7	94	-16.3	AVG
4882	61.73	-3.51	58.22	74	-15.78	Peak
4882	42.09	-3.51	38.58	54	-15.42	AVG
7323	59.76	-0.82	58.94	74	-15.06	Peak
7323	38.43	-0.82	37.61	54	-16.39	AVG

Remark:Factor=Antenna Factor+Cable Loss-Pre-amplifier

Vertical:

Frequency	Reading Result	Factor	Emission Level	Limits	Margin	Detector Type
(MHz)	(dBuV)	(dB)	(dBuV/m)	(dBuV/m)	(dB)	
2441	105.84	-5.71	100.13	114	-13.87	Peak
2441	82.07	-5.71	76.36	94	-17.64	AVG
4882	62.43	-3.51	58.92	74	-15.08	Peak
4882	44.56	-3.51	41.05	54	-12.95	AVG
7323	61.78	-0.82	60.96	74	-13.04	Peak
7323	40.06	-0.82	39.24	54	-14.76	AVG

Remark:Factor=Antenna Factor+Cable Loss-Pre-amplifier



CH High (2480MHz)

Horizontal:

Frequency	Reading Result	Factor	Emission Level	Limits	Margin	Detector Type
(MHz)	(dBuV)	(dB)	(dBuV/m)	(dBuV/m)	(dB)	
2480	107.24	-5.56	101.68	114	-12.32	Peak
2480	83.65	-5.56	78.09	94	-15.91	AVG
4960	63.72	-3.43	60.29	74	-13.71	Peak
4960	43.16	-3.43	39.73	54	-14.27	AVG
7440	64.08	-0.75	63.33	74	-10.67	Peak
7440	43.25	-0.75	42.5	54	-11.5	AVG

Remark:Factor=Antenna Factor+Cable Loss-Pre-amplifier

Vertical:

Frequency	Reading Result	Factor	Emission Level	Limits	Margin	Detector Type
(MHz)	(dBuV)	(dB)	(dBuV/m)	(dBuV/m)	(dB)	
2480	106.82	-5.56	101.26	114	-12.74	Peak
2480	82.46	-5.56	76.9	94	-17.1	AVG
4960	62.97	-3.43	59.54	74	-14.46	Peak
4960	44.15	-3.43	40.72	54	-13.28	AVG
7440	61.82	-0.75	61.07	74	-12.93	Peak
7440	42.73	-0.75	41.98	54	-12.02	AVG

Remark:Factor=Antenna Factor+Cable Loss-Pre-amplifier



Remark :

- (1) Measuring frequencies from 1 GHz to the 25 GHz °
- (2) “F” denotes fundamental frequency; “H” denotes spurious frequency. “E” denotes band edge frequency.
- (3) * denotes emission frequency which appearing within the Restricted Bands specified in provision of 15.205, then the general radiated emission limits in 15.209 apply.
- (4) Data of measurement within this frequency range shown “--- ” in the table above means the reading of emissions are attenuated more than 20dB below the permissible limits or the field strength is too small to be measured.
- (5) The IF bandwidth of EMI Test Receiver between 30MHz to 1GHz was 120KHz, 1 MHz for measuring above 1 GHz, below 30MHz was 10KHz. The resolution bandwidth of test receiver/spectrum analyzer is 1MHz and video bandwidth is 3MHz for peak measurement with peak detector at frequency above 1GHz. The resolution bandwidth of test receiver/spectrum analyzer is 1MHz and video bandwidth is 10Hz for Average measurement with peak detection at frequency above 1GHz.
- (6) When the test results of Peak Detected below the limits of Average Detected, the Average Detected is not need completed. For example: Top Channel at Fundamental 73.16dBuV/m(PK Value) <93.98(AV Limit), at harmonic 53.20 dBuV/m(PK Value) <54 dBuV/m(AV Limit), the Average Detected not need to completed.
- (7) All modes of operation were investigated and the worst-case emissions are reported.



5 BAND EDGE

5.1 Limits

FCC PART 15.249(d) Emissions radiated outside of the specified frequency bands, except for harmonics, shall be attenuated by at least 50 dB below the level of the fundamental or to the general radiated emission limits in §15.209, whichever is the lesser attenuation.

5.2 Test Procedure

The band edge compliance of RF radiated emission should be measured by following the guidance in ANSI C63.10 with respect to maximizing the emission by rotating the EUT, measuring the emission while the EUT is situated in three orthogonal planes (if appropriate), adjusting the measurement antenna height and polarization etc. Set RBW to 100KHz and VBM to 300KHz to measure the peak field strength and set RBW to 1MHz and VBW to 10Hz to measure the average radiated field strength. The conducted RF band edge was measured by using a spectrum analyzer. Set span wide enough to capture the highest in-band emission and the emission at the band edge. Set RBW to 100 KHz and VBW to 300 KHz, to measure the conducted peak band edge.

5.3 Test Result

PASS

Radiated Band Edge Test:

Operation Mode: GFSK TX CH Low (2402MHz)

Horizontal (Worst case)

Frequency (MHz)	Reading Result (dBuV)	Factor (dB)	Emission Level (dBuV/m)	Limits (dBuV/m)	Margin (dB)	Detector Type
2310	54.32	-5.81	48.51	74	-25.49	Peak
2310	43.26	-5.81	37.45	54	-16.55	AVG
2390	56.17	-5.84	50.33	74	-23.67	Peak
2390	43.57	-5.84	37.73	54	-16.27	AVG
2400	59.68	-5.95	53.73	74	-20.27	Peak
2400	42.05	-5.95	36.1	54	-17.9	AVG
Remark:Factor=Antenna Factor+Cable Loss-Pre-amplifier						

Vertical:

Frequency (MHz)	Reading Result (dBuV)	Factor (dB)	Emission Level (dBuV/m)	Limits (dBuV/m)	Margin (dB)	Detector Type
2310	56.78	-5.81	50.97	74	-23.03	Peak
2310	44.16	-5.81	38.35	54	-15.65	AVG
2390	55.72	-5.84	49.88	74	-24.12	Peak
2390	43.19	-5.84	37.35	54	-16.65	AVG
2400	57.42	-5.95	51.47	74	-22.53	Peak
2400	44.93	-5.95	38.98	54	-15.02	AVG
Remark:Factor=Antenna Factor+Cable Loss-Pre-amplifier						



Operation Mode: GFSK TX CH High (2480MHz)

Horizontal (Worst case)

Frequency	Reading Result	Factor	Emission Level	Limits	Margin	Detector Type
(MHz)	(dBuV)	(dB)	(dBuV/m)	(dBuV/m)	(dB)	
2483.5	57.15	-5.81	51.34	74	-22.66	Peak
2483.5	43.97	-5.81	38.16	54	-15.84	AVG
2500	56.42	-6.06	50.36	74	-23.64	Peak
2500	42.09	-6.06	36.03	54	-17.97	AVG

Remark:Factor=Antenna Factor+Cable Loss-Pre-amplifier

Vertical:

Frequency	Reading Result	Factor	Emission Level	Limits	Margin	Detector Type
(MHz)	(dBuV)	(dB)	(dBuV/m)	(dBuV/m)	(dB)	
2483.5	56.34	-5.81	50.53	74	-23.47	Peak
2483.5	44.18	-5.81	38.37	54	-15.63	AVG
2500	55.83	-6.06	49.77	74	-24.23	Peak
2500	43.52	-6.06	37.46	54	-16.54	AVG

Remark:Factor=Antenna Factor+Cable Loss-Pre-amplifier



Conducted Band Edge Test: GFSK

2402

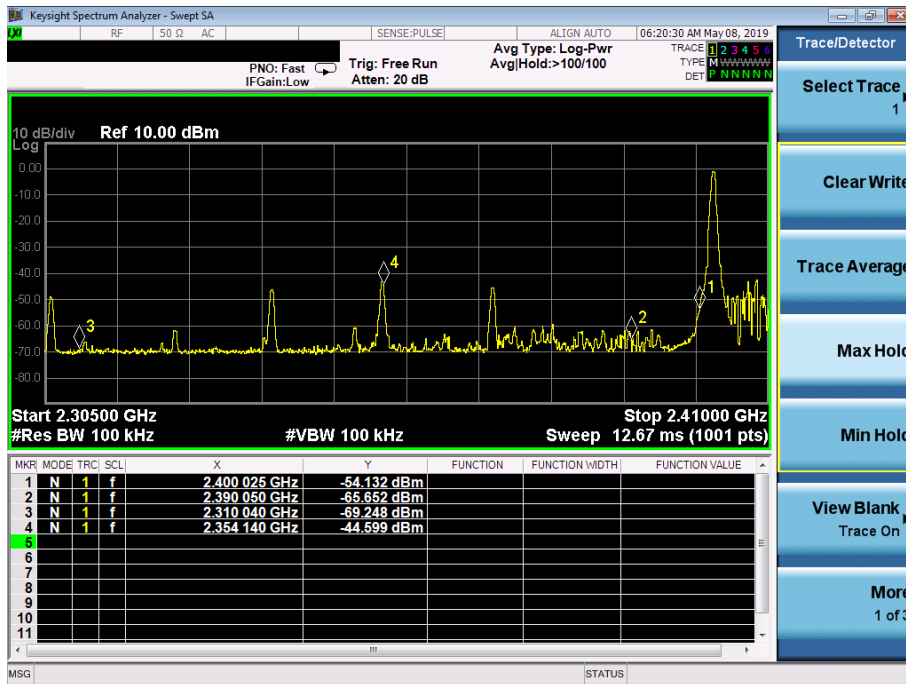

2480

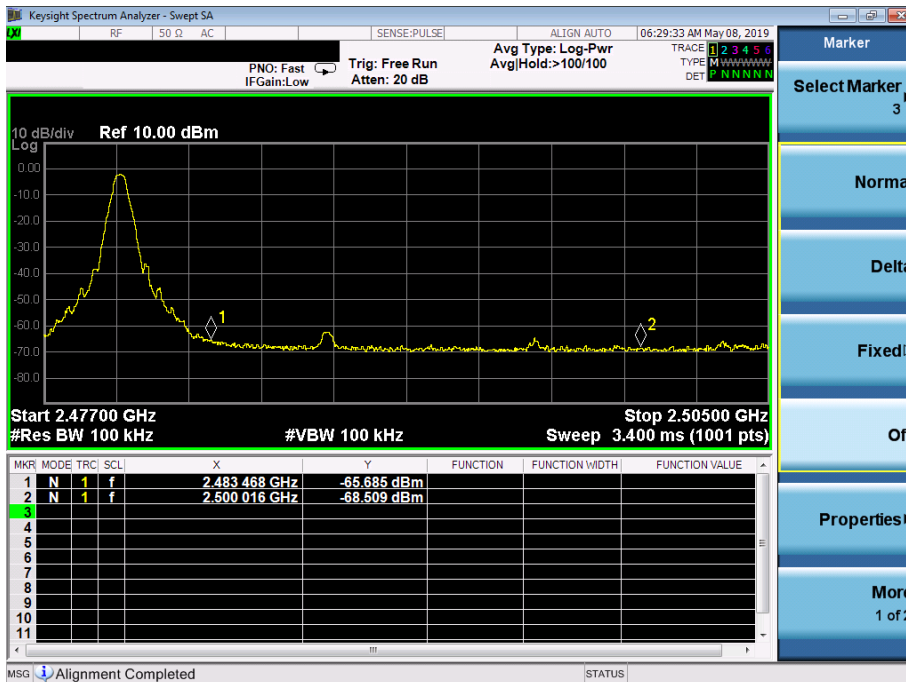



Conducted Band Edge Test: 8DPSK

2402

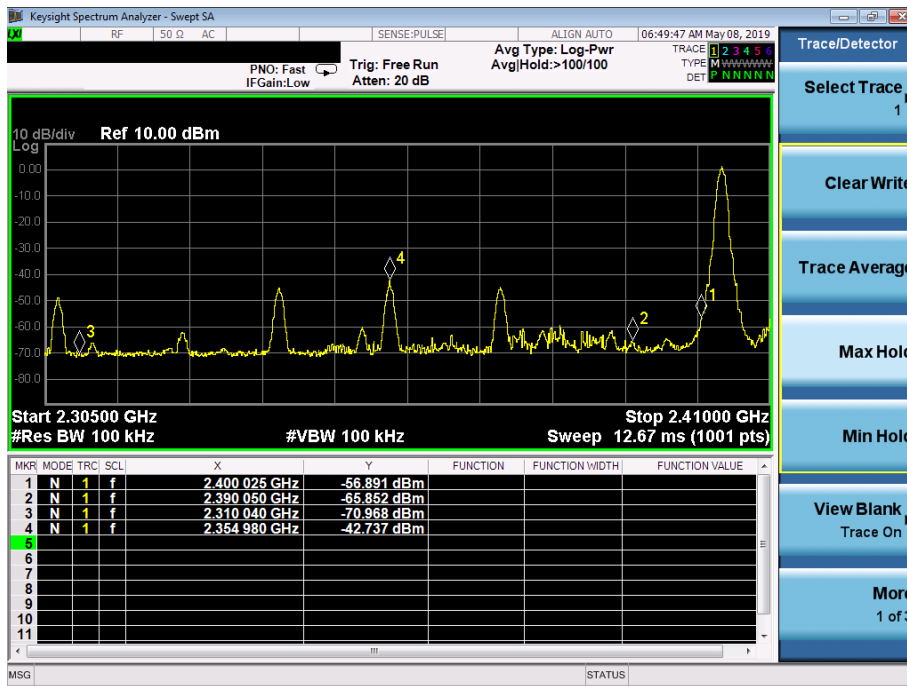

2480

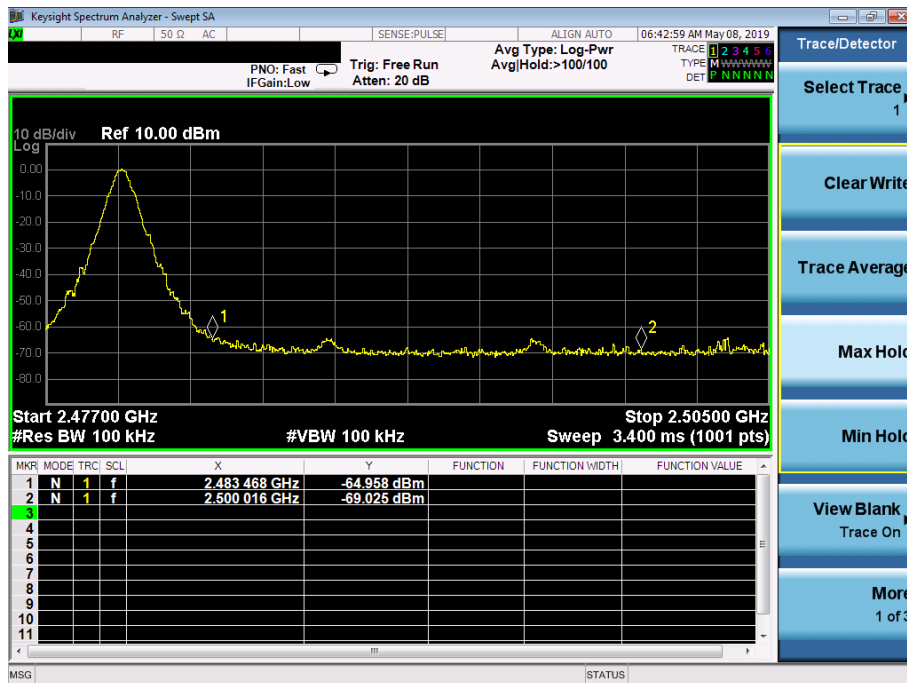



6 OCCUPIED BANDWIDTH MEASUREMENT

6.1 Test Setup

Same as Radiated Emission Measurement

6.2 Test Procedure

1. The EUT was placed on a turn table which is 0.8m above ground plane.
2. Set EUT as normal operation.
3. Based on ANSI C63.10 section 6.9.2: RBW= 100KHz. VBW= 300 KHz, Span=2MHz.
4. The useful radiated emission from the EUT was detected by the spectrum analyser with peak detector.

6.3 Measurement Equipment Used

Same as Radiated Emission Measurement

6.4 Test Result

PASS

Modulation Type	Frequency	20dB Bandwidth (MHz)	Result
GFSK	2402 MHz	1.062	PASS
	2441 MHz	1.051	PASS
	2480 MHz	1.024	PASS

CH: 2402MHz

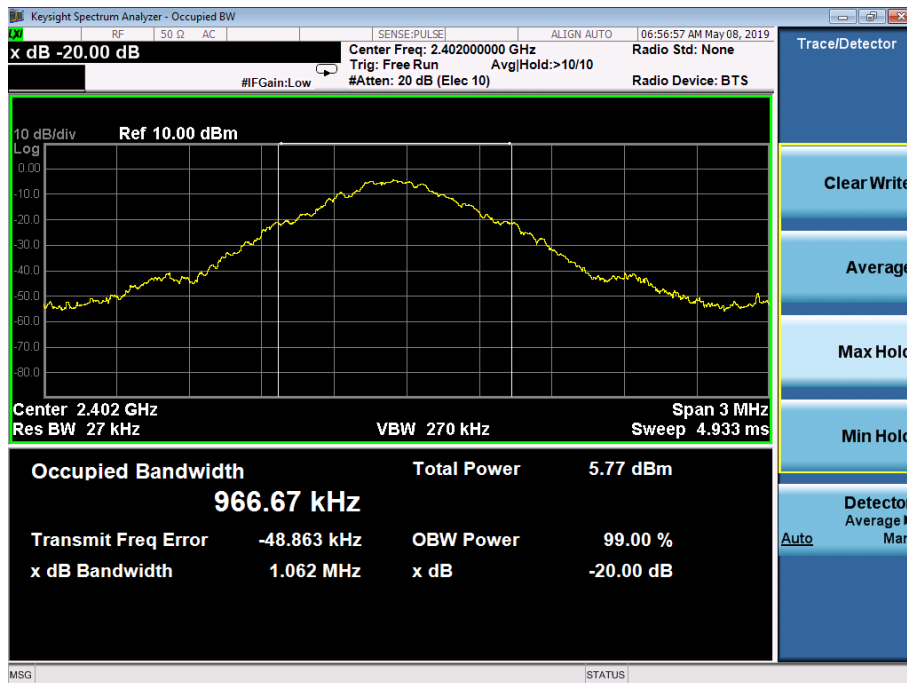



CH: 2440MHz

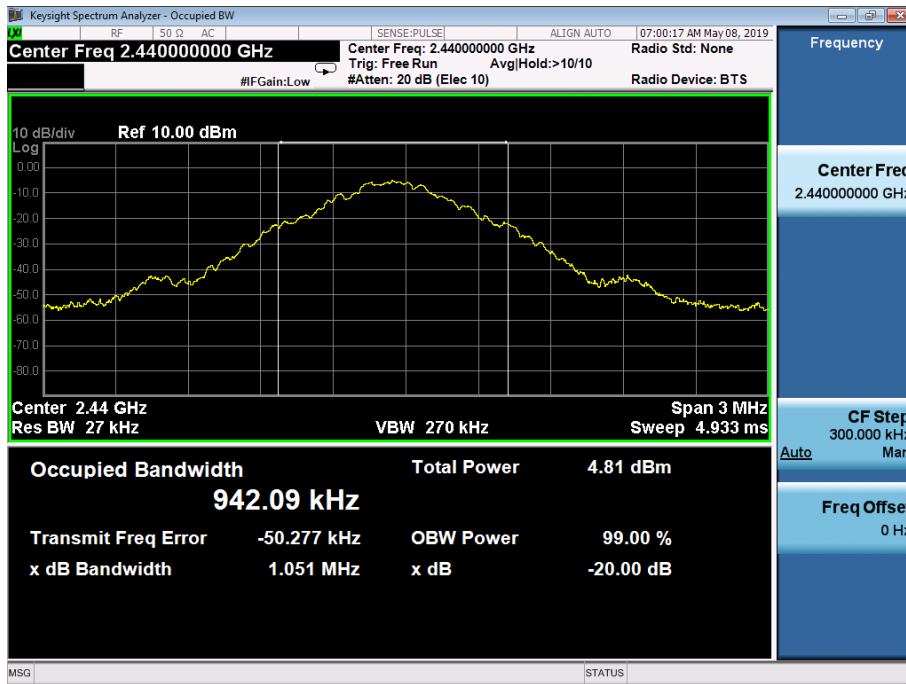

CH: 2480MHz

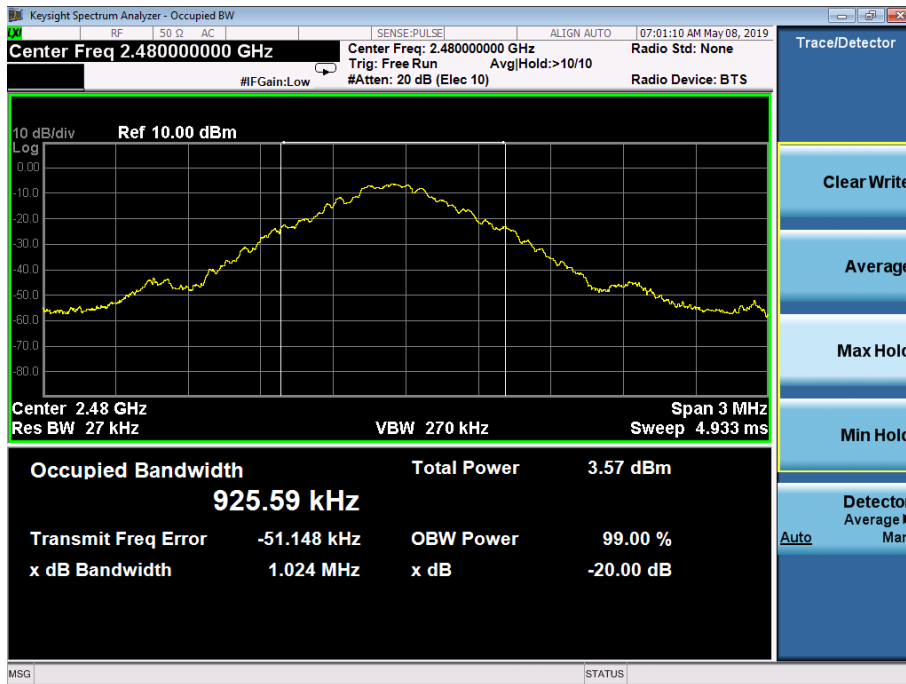



Modulation Type	Frequency	20dB Bandwidth (MHz)	Result
$\pi/4$ DQPSK	2402 MHz	1.473	PASS
	2441 MHz	1.441	PASS
	2480 MHz	1.256	PASS

CH: 2402MHz

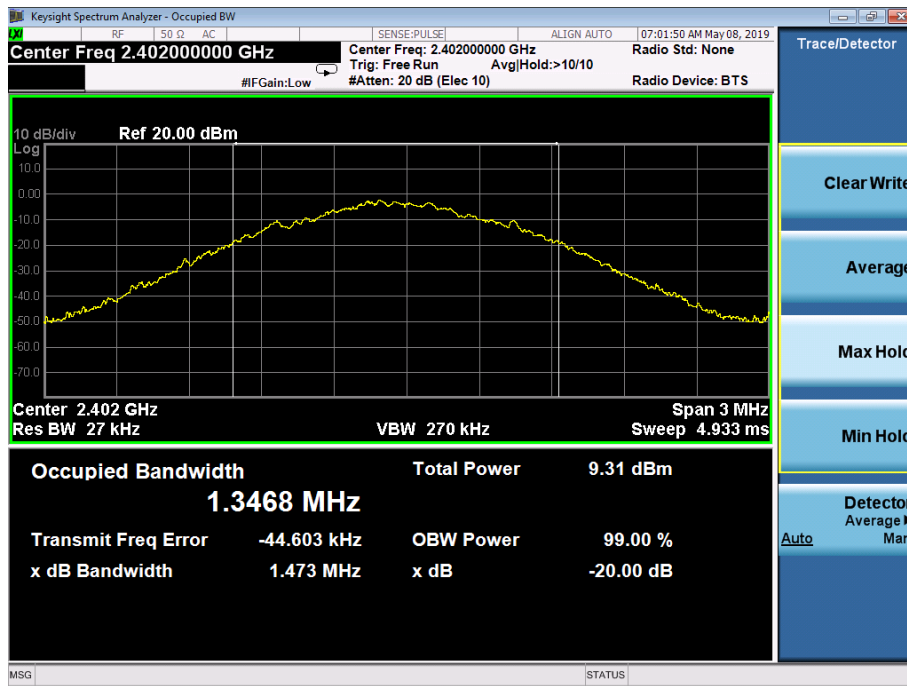



CH: 2440MHz

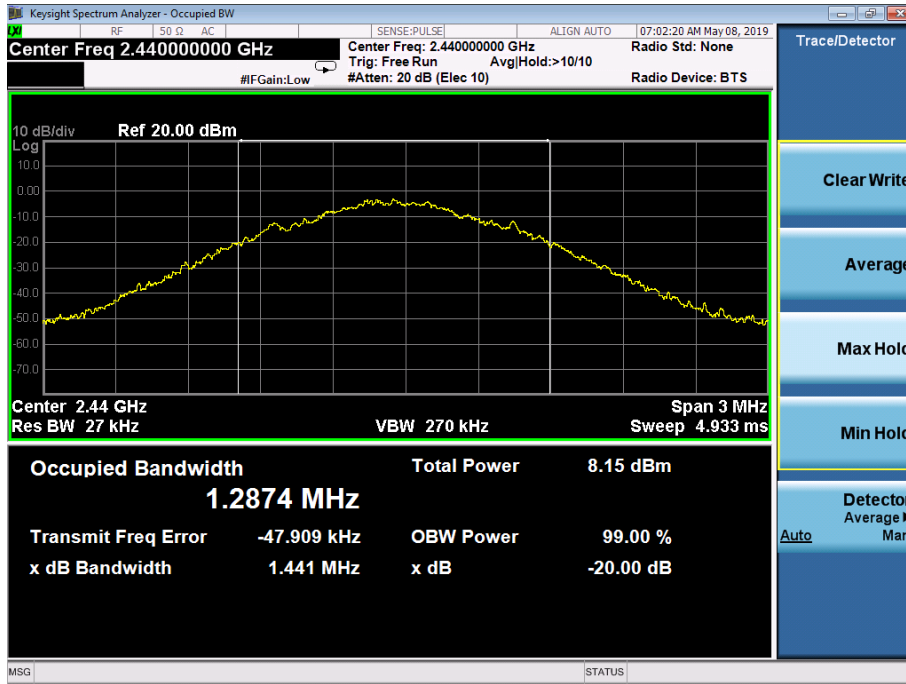

CH: 2480MHz

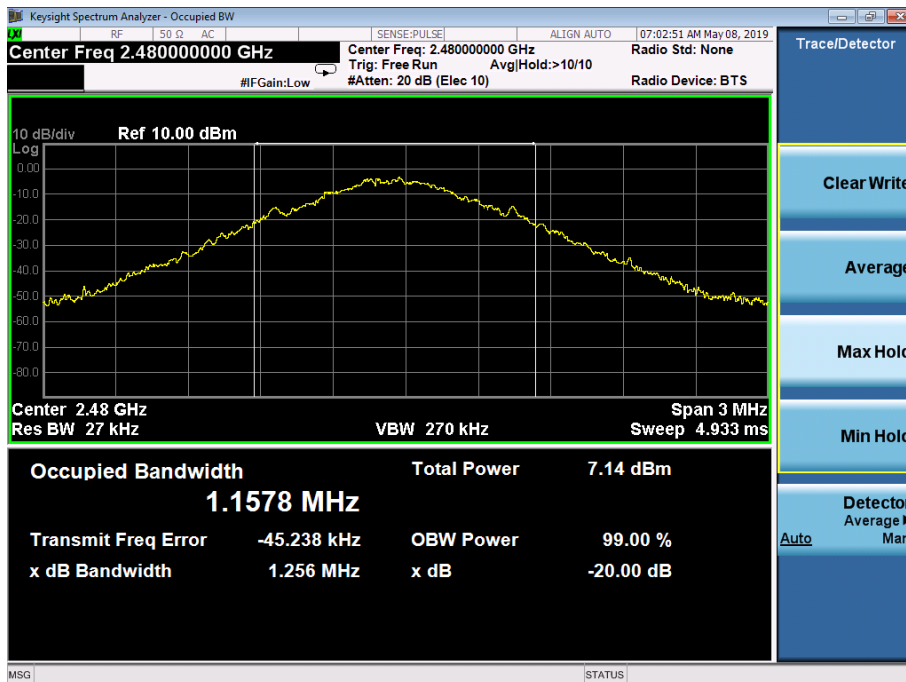



Modulation Type	Frequency	20dB Bandwidth (MHz)	Result
8DPSK	2402 MHz	1.799	PASS
	2441 MHz	1.653	PASS
	2480 MHz	1.545	PASS

CH: 2402MHz

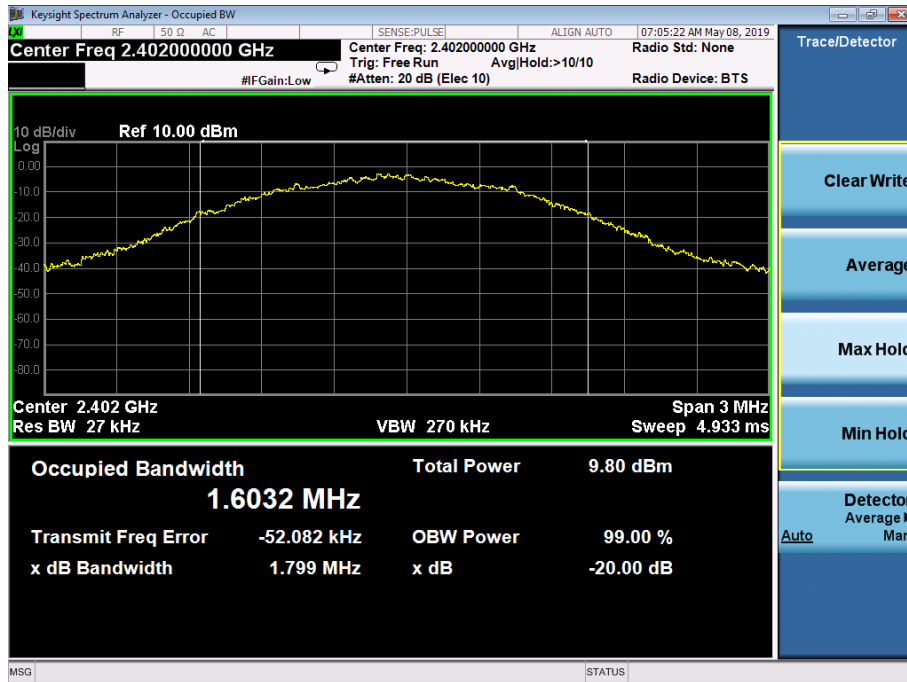



CH: 2440MHz

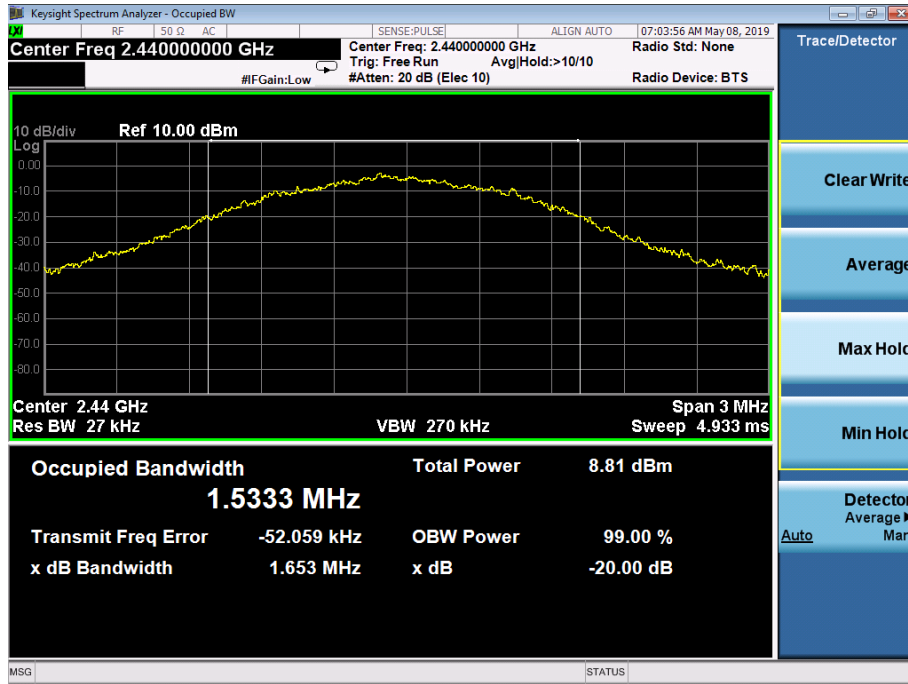

CH: 2480MHz

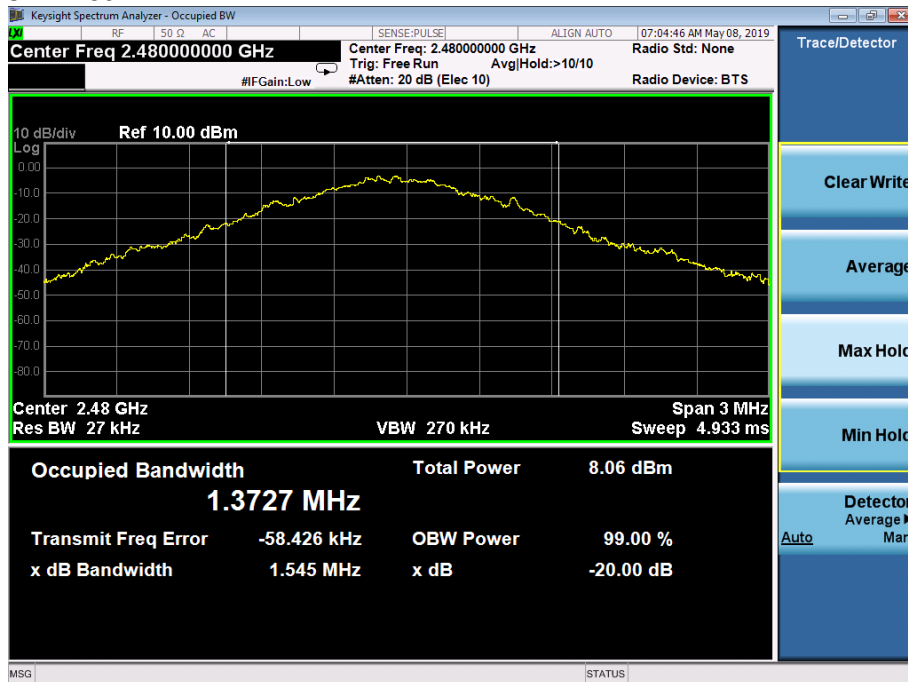

7 ANTENNA REQUIREMENT

Standard Applicable

For intentional device, according to FCC 47 CFR Section 15.203, an intentional radiator shall be designed to ensure that no antenna other than that furnished by the responsible party shall be used with the device. And according to FCC 47 CFR Section 15.249, if transmitting antennas of directional gain greater than 6dBi are used, the power shall be reduced by the amount in dB that the directional gain of the antenna exceeds 6dBi.

Refer to statement below for compliance.

The manufacturer may design the unit so that the user can replace a broken antenna, but the use of a standard antenna jack or electrical connector is prohibited. Further, this requirement does not apply to intentional radiators that must be professionally installed.

Antenna Connected Construction

The antenna used in this product is a PCB Antenna, The directional gains of antenna used for transmitting is 0dBi.

ANTENNA

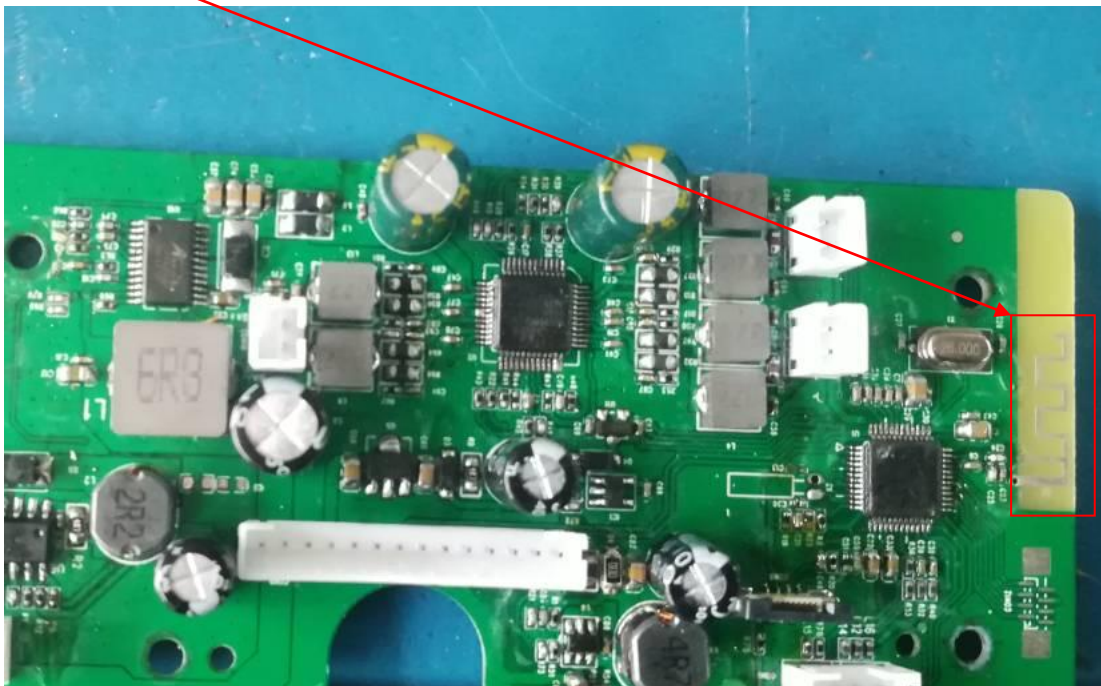

8 PHOTOGRAPH OF TEST

8.1 Radiated Emission

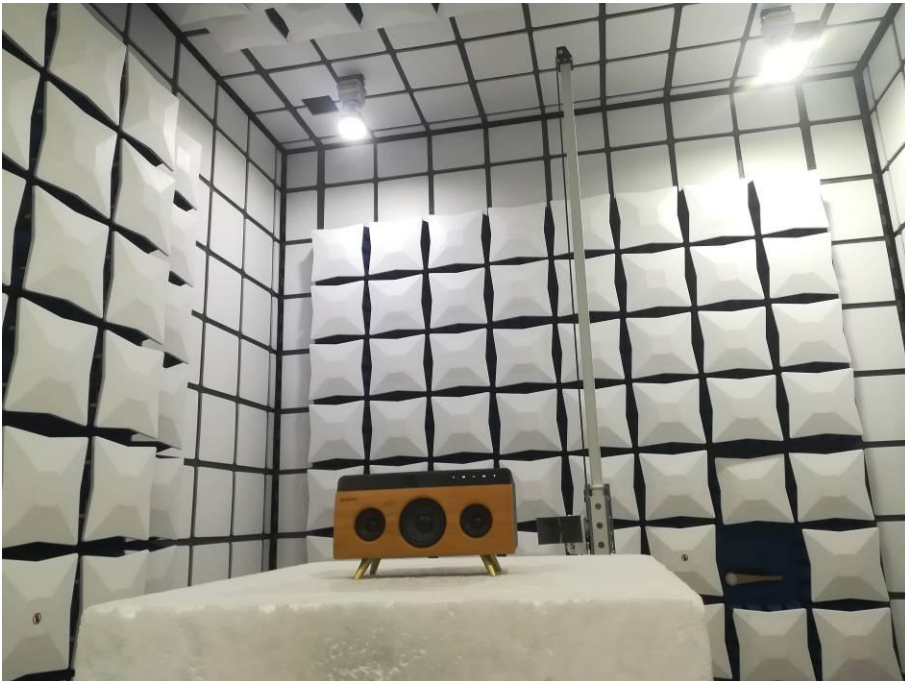
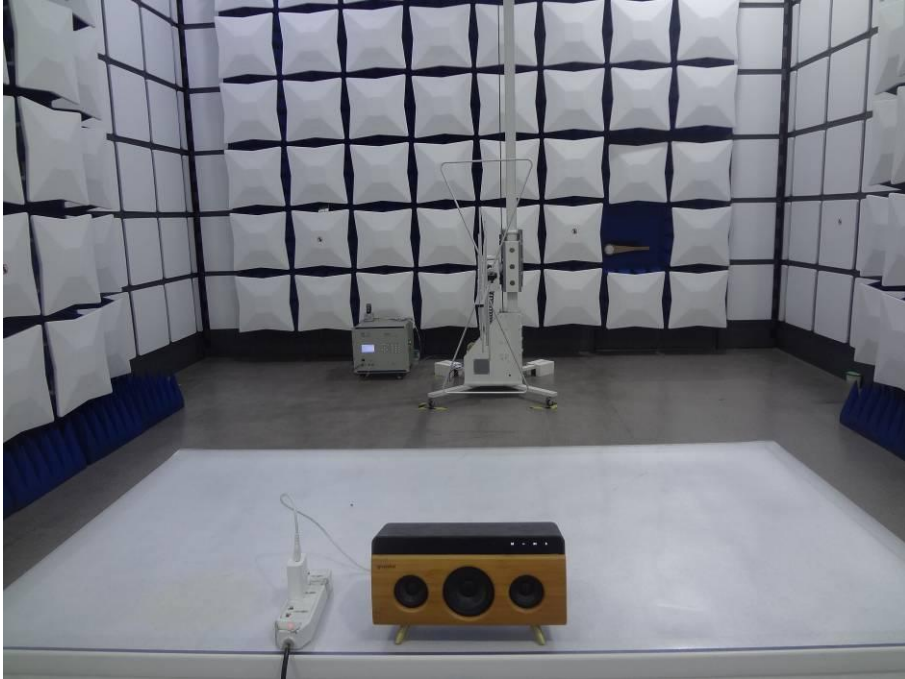



8.2 Conducted Emission

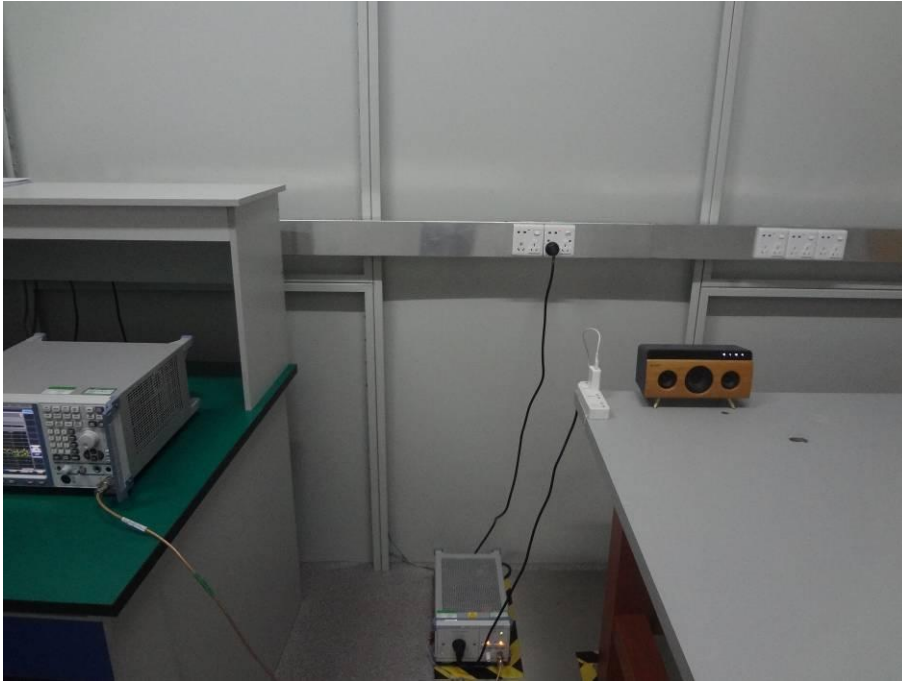

EUT
Photo 1



Photo 2



Photo 3

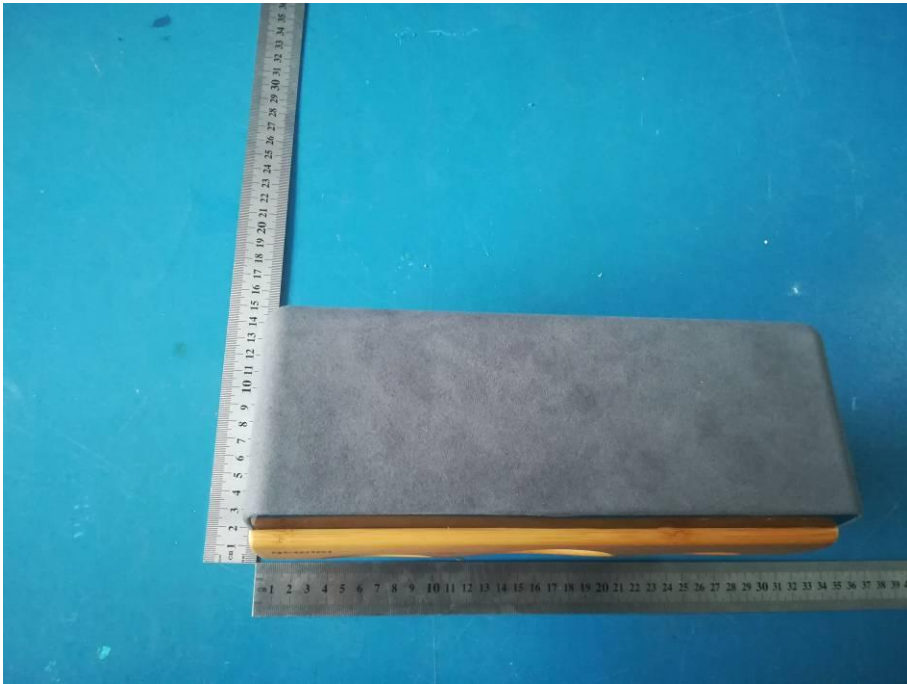

Photo 4



Photo 5

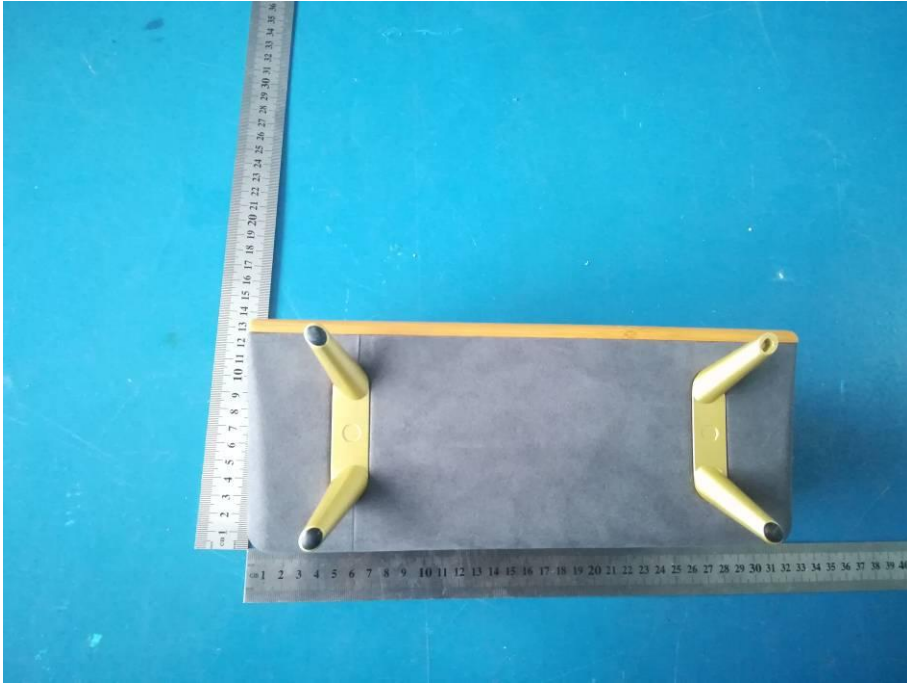

Photo 6

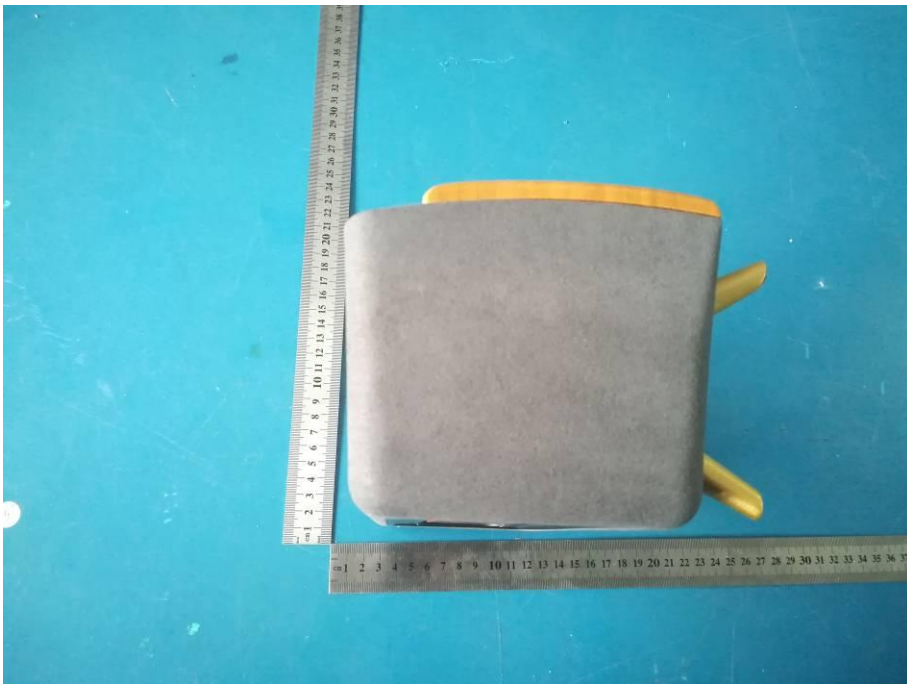

Photo 7

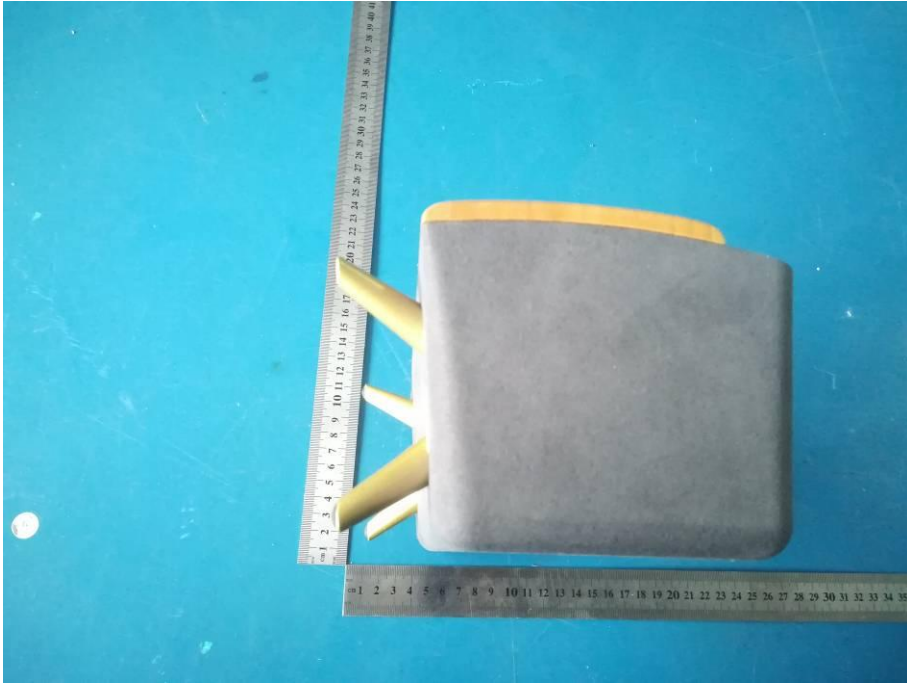

Photo 8



Photo 9

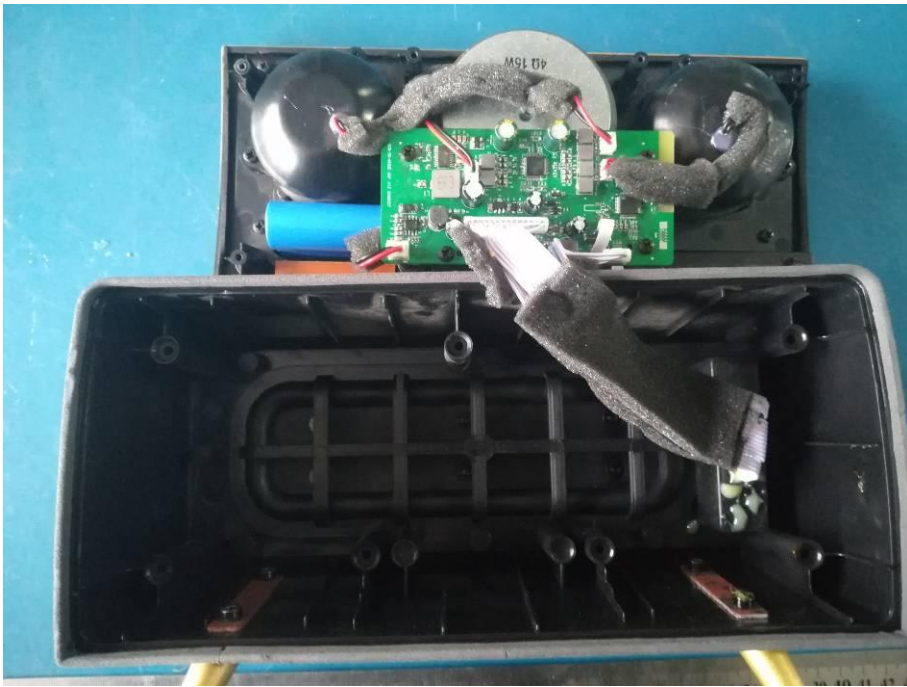

Photo 10

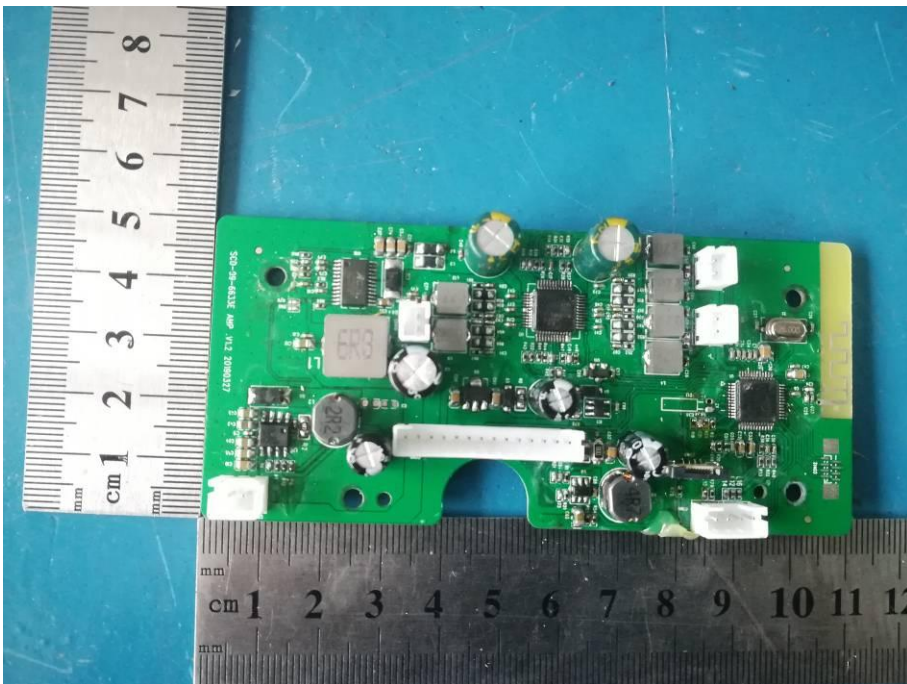

Photo 11

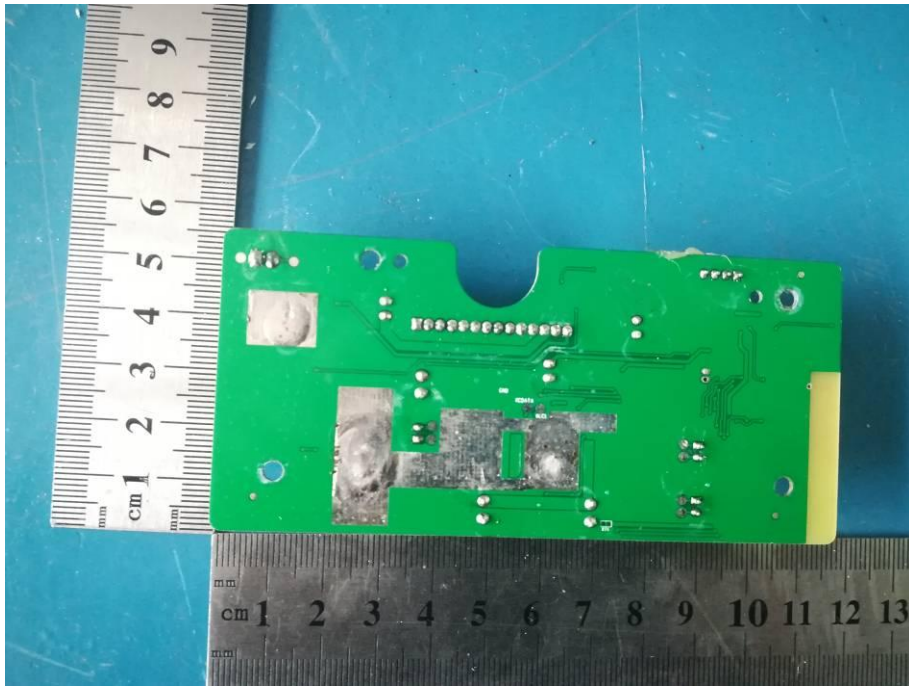

Photo 12



Photo 13

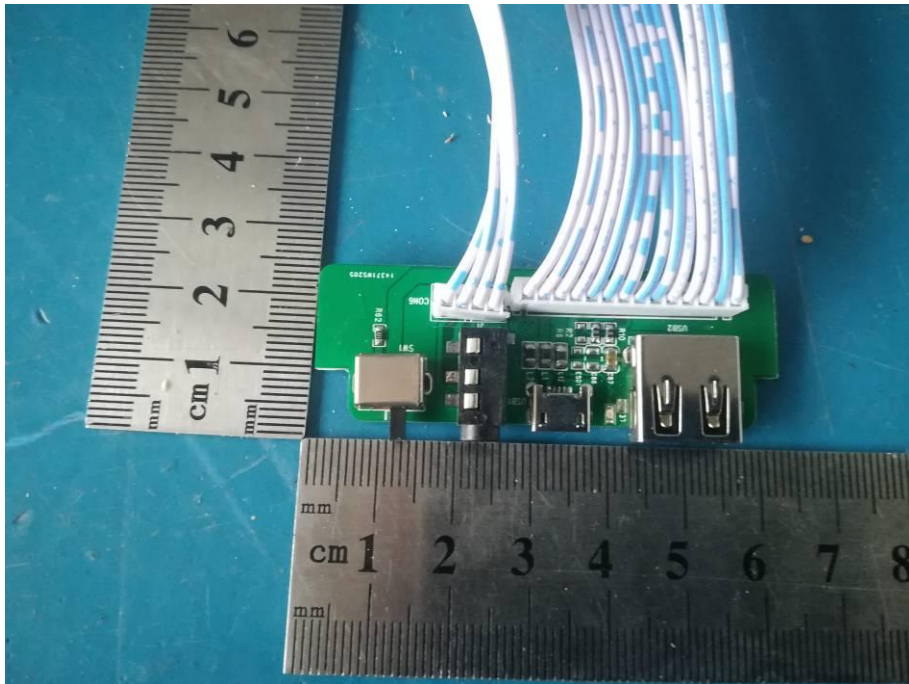
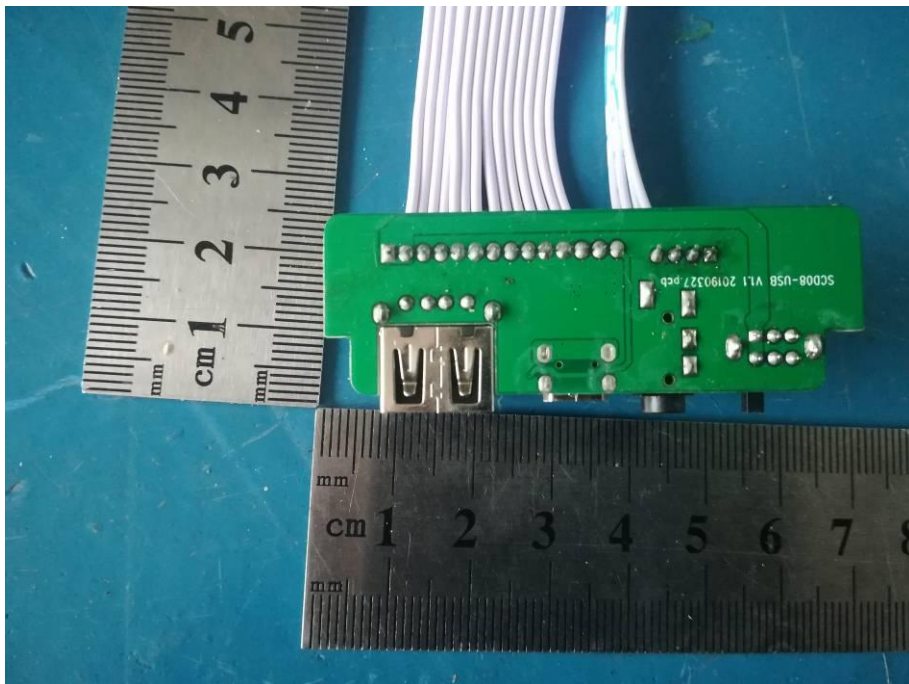

Photo 14



--The end of report--