

# TEST REPORT

**Product Name** : Walkie Talkies  
**Model Number** : WT3-01056A  
**FCC ID** : 2AE6BWT3-01056A

**Prepared for** : Chenghai Xianxin Plastic Toys Factory  
**Address** : ZhenXing Road,PuMei,Chenghai District,Shantou City,  
Guangdong,China

**Prepared by** : EMTEK (SHENZHEN) CO., LTD.  
**Address** : Bldg 69, Majialong Industry Zone, Nanshan District,  
Shenzhen, Guangdong, China

Tel: (0755) 26954280  
Fax: (0755) 26954282

**Report Number** : ES200429049W  
**Date(s) of Tests** : May 8, 2020 to May 25, 2020  
**Date of issue** : May 27, 2020

## TABLE OF CONTENTS

<b>1</b>	<b>TEST RESULT CERTIFICATION .....</b>	<b>3</b>
<b>2</b>	<b>EUT TECHNICAL DESCRIPTION .....</b>	<b>4</b>
<b>3</b>	<b>SUMMARY OF TEST RESULT .....</b>	<b>5</b>
<b>4</b>	<b>TEST METHODOLOGY .....</b>	<b>6</b>
4.1	GENERAL DESCRIPTION OF APPLIED STANDARDS .....	6
4.2	MEASUREMENT EQUIPMENT USED .....	6
4.3	DESCRIPTION OF TEST MODES .....	8
4.4	ENVIROMENTAL CONDITIONS .....	8
4.5	MODULATION TYPE .....	9
<b>5</b>	<b>FACILITIES AND ACCREDITATIONS .....</b>	<b>10</b>
5.1	FACILITIES.....	10
5.2	LABORATORY ACCREDITATIONS AND LISTINGS .....	10
<b>6</b>	<b>TEST SYSTEM UNCERTAINTY .....</b>	<b>11</b>
<b>7</b>	<b>SETUP OF EQUIPMENT UNDER TEST .....</b>	<b>12</b>
7.1	RADIO FREQUENCY TEST .....	12
7.2	RADIO FREQUENCY TEST .....	12
7.3	CONDUCTED EMISSION TEST SETUP .....	14
7.4	BLOCK DIAGRAM CONFIGURATION OF TEST SYSTEM.....	15
7.5	SUPPORT EQUIPMENT.....	15
<b>8</b>	<b>TEST REQUIREMENTS .....</b>	<b>16</b>
8.1	CARRIER OUTPUT POWER .....	16
8.2	99% OCCUPIED BANDWIDTH & 26DB BANDWIDTH.....	18
8.3	EMISSION MASK .....	20
8.4	MODULATION LIMIT .....	22
8.5	AUDIO FREQUENCY RESPONSE .....	25
8.6	FREQUENCY STABILITY .....	28
8.7	RADIATED SPURIOUS EMISSION .....	29

# 1 TEST RESULT CERTIFICATION

Applicant : Chenghai Xianxin Plastic Toys Factory  
 Address : ZhenXing Road,PuMei,Chenghai District,Shantou City,Guangdong,China  
 Manufacturer : SHANTOU CHENGHAI GUANGYI XIANXIN PLASTIC TOYS FACTORY  
 Address : BUMEI INDUSTRIAL AREA, GUANGYI, CHENGHAI, SHANTOU, GUANGDONG  
 EUT : Walkie Talkies  
 Model Name : WT3-01056A  
 Trademark : N/A

Measurement Procedure Used:

APPLICABLE STANDARDS	
STANDARD	TEST RESULT
FCC 47 CFR Part 2 , Subpart J FCC 47 CFR Part 95, Subpart B	PASS

The above equipment was tested by EMTEK (SHENZHEN) CO., LTD. The test data, data evaluation, test procedures, and equipment configurations shown in this report were made in accordance with the procedures given in ANSI C63.10 (2013) and the energy emitted by the sample EUT tested as described in this report is in compliance with the requirements of FCC Rules Part 2 and Part 95 B

The test results of this report relate only to the tested sample identified in this report.

Date of Test : May 8, 2020 to May 25, 2020

Prepared by :   
 Sewen Guo /Editor

Reviewer :   
 Joe Xia/Supervisor

Approved & Authorized Signer :   
 Lisa Wang/Manager



## 2 EUT TECHNICAL DESCRIPTION

Characteristics	Description
Product	Walkie Talkies
Model Number	WT3-01056A
Modulation	FM(Analog)
Operating Frequency Range	462.5625MHz
Emission Designator:	11K0F3E
Transmit Power Max	11.63dBm
Antenna Type	Metal spring antenna
Antenna Gain	0 dBi
Power supply	DC 6.0V for Battery
Hardware version	V1.0
Software version	V1.0
Temperature Range	-10°C ~ +45°C

**Note:**

- 1) For more details, please refer to the User's manual of the EUT.
- 2) According to FCC Part 2.202 requirements, the Necessary Bandwidth is calculated as follows:  
 For FM Voice Modulation  
 Channel Spacing = 12.5 KHz, D = 2.5 KHz max, K = 1, M = 3 KHz  
 $B_n = 2M + 2DK = 2*3 + 2*2.5*1 = 11 \text{ KHz}$   
 Emission designation: 11K0F3E

### 3 SUMMARY OF TEST RESULT

FCC Part Clause	Test Parameter	Verdict	Remark
Part 95.567 Part 2.1046(a)	Carrier Output Power(ERP)	PASS	
Part 95.573 Part 2.1049	99% Occupied Bandwidth & 26dB bandwidth	PASS	
Part 95.579(a)(1)(2)(3) Part 2.1049	Emission Mask	PASS	
Part 95.575 Part 2.1047(b)	Modulation Limit	PASS	
Part 95.575 Part 2.1047(a)	Audio Frequency Response	PASS	
Part 95.565 Part 2.1055	Frequency Stability	PASS	
Part 95.579(a)(3) Part 2.1053	Transmit Radiated Spurious Emission	PASS	
NOTE1:N/A (Not Applicable)			

#### RELATED SUBMITTAL(S) / GRANT(S):

This submittal(s) (test report) is intended for FCC ID: 2AE6BWT3-01056A filing to comply with Section Part 95, Subpart B Rules.

## 4 TEST METHODOLOGY

### 4.1 GENERAL DESCRIPTION OF APPLIED STANDARDS

According to its specifications, the EUT must comply with the requirements of the following standards:  
 FCC 47 CFR Part 2, Frequency allocations and radio treaty matters; General rules and regulations  
 FCC 47 CFR Part 95, Subpart B—Family Radio Service (FRS)

ANSI C63.10: American National Standard of Procedures for Compliance Testing of Unlicensed Wireless Devices.

ANSI/TIA-603-E: Land Mobile FM or PM Communications Equipment and Performance Standards

ANSI C63.4: American National Standard for Methods of Measurement of Radio-Noise Emissions from Low-Voltage Electrical and Electronic Equipment in the Range of 9 kHz to 40 GHz

### 4.2 MEASUREMENT EQUIPMENT USED

#### 4.2.1 Radiated Emission Test Equipment

Equipment	Manufacturer	Model No.	Serial No.	Last Cal.	Cal. Interval
EMI Test Receiver	Rohde & Schwarz	ESU 26	100154	May 19, 2020	1 Year
Pre-Amplifie	Lunar EM	LNA30M3G-25	J10100000070	June 6, 2019	1 Year
Bilog Antenna	Schwarzbeck	VULB9163	659	Sep 22, 2019	2 Year
Horn antenna	Schwarzbeck	BBHA9120D	9120D-1177	June 6, 2018	2 Year
Pre-Amplifie	SKET	LNPA_0118G-45	SK2019051801	May 19, 2020	1 Year
Loop Antenna	Schwarzbeck	FMZB1519	1519-012	July 14, 2019	2 Year
Spectrum Analyzer	Rohde & Schwarz	FSV40	100967	May 19, 2020	1 Year
Horn antenna	Schwarzbeck	BBHA9120D	9120D-1198	June 16, 2019	2 Year
Bilog Antenna	Schwarzbeck	VULB9163	660	July 16, 2019	2 Year
Cable	H+B	NmSm-05-C15052	N/A	May 19, 2020	1 Year
Cable	H+B	NmSm-2-C15201	N/A	May 19, 2020	1 Year
Cable	H+B	NmNm-7-C15702	N/A	May 19, 2020	1 Year
Cable	H+B	SAC-40G-1	414	May 19, 2020	1 Year
Cable	H+B	SUCOFLEX104	MY14871/4	May 19, 2020	
Cable	H+B	BLU18A-NmSm-6500	D8501	May 19, 2020	1 Year
Band reject Filter(50dB)	WI/DE	WRCGV-2400(2400-2485MHz)	2	May 19, 2020	1 Year

#### 4.2.2 Radio Frequency Test Equipment

Equipment	Manufacturer	Model No.	Serial No.	Last Cal.	Cal. Interval
Vector Signal Generator	Agilent	N5182B	My53050553	May 19, 2020	1 Year
Analog Signal Generator	Agilent	N5171B	My53050878	May 19, 2020	1 Year
Signal Analyzer	Agilent	N9010A	My53470879	May 19, 2020	1 Year
Power Analyzer	Agilent	PS-X10-200	N/A	May 19, 2020	1 Year
Wideband Radio Communication Tester	R&S	CMW500	1201.0002K50-140822zk	May 19, 2020	1 Year
Test Accessories	Agilent	PS-X10-100	N/A	May 19, 2020	1 Year
Temperature&Humidity test chamber	ESPEC	EL-02KA	12107166	May 19, 2020	1 Year
Blocking Box	Agilent	AD211	N/A	May 19, 2020	1 Year
Spectrum Analyzer	Rohde & Schwarz	FSV40	100967	May 19, 2020	1 Year
Cell site test set	Hewlett packard	8921A	3524A02336	May 19, 2020	1 Year

**Remark:** Each piece of equipment is scheduled for calibration once a year.

### 4.3 DESCRIPTION OF TEST MODES

The EUT has been tested under its typical operating condition.

The EUT configuration for testing is installed on RF field strength measurement to meet the Commissions requirement and operating in a manner which intends to maximize its emission characteristics in a continuous normal application.

The Transmitter was operated in the normal operating mode. The TX frequency was fixed which was for the purpose of the measurements.

Test of channel included the lowest and middle and highest frequency to perform the test, then record on this report.

Frequency and Channel list

Channel	Frequency (MHz)	Channel	Frequency (MHz)	Channel	Frequency (MHz)
1	462.5625				

Test Frequency and channel

Lowest Frequency		Middle Frequency		Highest Frequency	
Channel	Frequency (MHz)	Channel	Frequency (MHz)	Channel	Frequency (MHz)
1	462.5625				

### 4.4 ENVIROMENTAL CONDITIONS

Norminal Test Voltage:	VN = DC 6.0V
Extrem Test Voltage @115%VN:	VH = DC 6.9V
Extrem Test Voltage @85%VN:	VL = DC 5.1V



#### 4.5 MODULATION TYPE

Modulation Type	Description
UM	Un-modulation
AM2	Apply a 1000 Hz tone and adjust the audio frequency generator to produce 20% of the rated system deviation.
AM6	Apply a 1000 Hz modulating signal to the transmitter from the audio frequency generator, and adjust the level to obtain 60% of full rated system deviation, then increase the level from the audio generator by 20 dB
AM5	Modulate the transmitter with a 2500 Hz sine wave at an input level 16 dB greater than that necessary to produce 50% of rated system deviation.

Test item	Modulation Type	Test mode
Output Power(ERP)	UM	TX-FRS
99% Occupied Bandwidth & 26dB bandwidth	AM6	TX-FRS
Emission Mask	AM5	TX-FRS
Modulation Limit	AM6	TX-FRS
Audio Frequency Response	AM2	TX-FRS
Frequency Stability	UM	TX-FRS
Transmit Radiated Spurious Emission	AM5	TX-FRS

## 5 FACILITIES AND ACCREDITATIONS

### 5.1 FACILITIES

All measurement facilities used to collect the measurement data are located at

Bldg 69, Majialong Industry Zone District, Nanshan District, Shenzhen, China

The sites are constructed in conformance with the requirements of ANSI C63.7, ANSI C63.10 and CISPR Publication 22.

### 5.2 LABORATORY ACCREDITATIONS AND LISTINGS

#### Site Description

EMC Lab.	: Accredited by CNAS, 2018.11.30 The certificate is valid until 2022.10.28 The Laboratory has been assessed and proved to be in compliance with CNAS-CL01:2006 (identical to ISO/IEC 17025:2017) The Certificate Registration Number is L2291
	Accredited by FCC, August 09, 2018 Designation Number: CN1204 Test Firm Registration Number: 882943 Accredited by A2LA, August 08, 2018 The Certificate Registration Number is 4321.01
	Accredited by Industry Canada, November 09, 2018 The Conformity Assessment Body Identifier is CN0008
Name of Firm	: EMTEK(SHENZHEN) CO., LTD.
Site Location	: Bldg 69, Majialong Industry Zone, Nanshan District, Shenzhen, Guangdong, China

## 6 TEST SYSTEM UNCERTAINTY

The following measurement uncertainty levels have been estimated for tests performed on the apparatus:

Parameter	Uncertainty
Radio Frequency	$\pm 1 \times 10^{-5}$
Maximum Peak Output Power Test	$\pm 1.0\text{dB}$
Conducted Emissions Test	$\pm 2.0\text{dB}$
Radiated Emission Test	$\pm 2.0\text{dB}$
Occupied Bandwidth Test	$\pm 1.0\text{dB}$
All emission, radiated	$\pm 3\text{dB}$
Antenna Port Emission	$\pm 3\text{dB}$
Temperature	$\pm 0.5^\circ\text{C}$
Humidity	$\pm 3\%$

Measurement Uncertainty for a level of Confidence of 95%



## 7 SETUP OF EQUIPMENT UNDER TEST

### 7.1 RADIO FREQUENCY TEST

The FRS component's antenna ports(s) of the EUT are connected to the measurement instrument per an appropriate attenuator. The EUT is controlled by PC/software to emit the specified signals for the purpose of measurements.

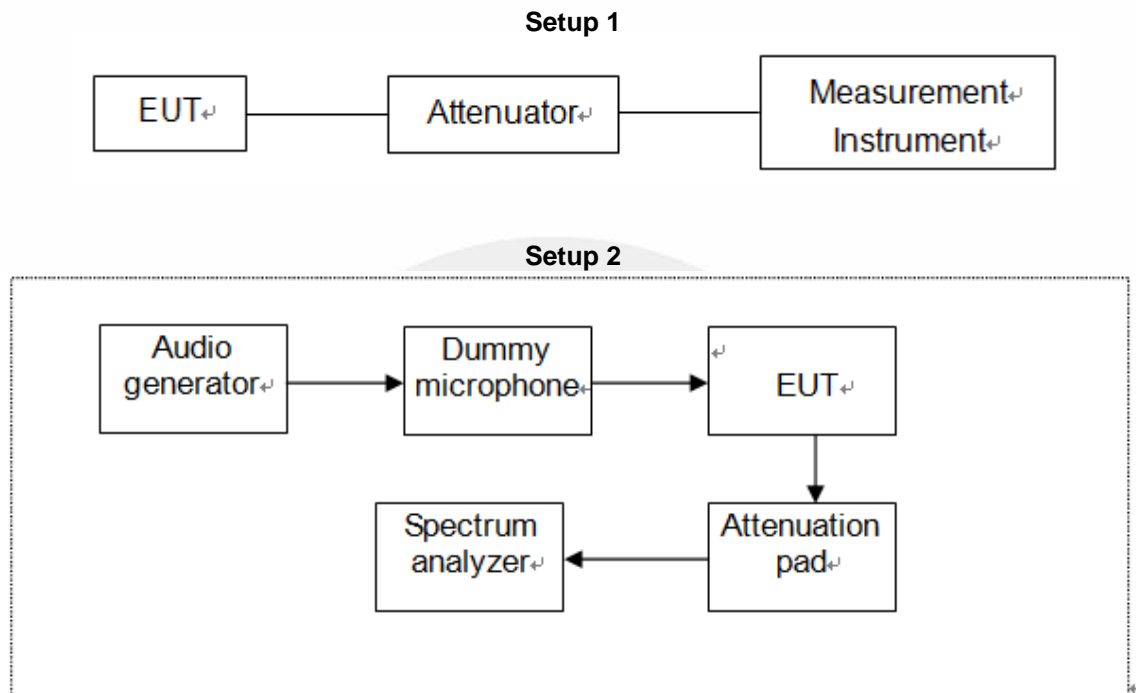

### 7.2 RADIO FREQUENCY TEST

The test site semi-anechoic chamber has met the requirement of NSA tolerance 4 dB according to the standards: ANSI C63.10. The test distance is 3m. The setup is according to the requirements in Section 13.1.4.1 of ANSI C63.10-2013 and CAN/CSA-CEI/IEC CISPR 22.

Below 30MHz:

The EUT is placed on a turntable 0.8 meters above the ground in the chamber, 3 meter away from the antenna (loop antenna). The Antenna should be positioned with its plane vertical at the specified distance from the EUT and rotated about its vertical axis for maximum response at each azimuth about the EUT. The center of the loop shall be 1 m above the ground. For certain applications, the loop antenna plane may also need to be positioned horizontally at the specified distance from the EUT.

30MHz-1GHz:

The EUT is placed on a turntable 0.8 meters above the ground in the chamber, 3 meter away from the antenna. The maximal emission value is acquired by adjusting the antenna height, polarisation and turntable azimuth. Normally, the height range of antenna is 1 m to 4 m, the azimuth range of turntable is 0° to 360°, and the receive antenna has two polarizations Vertical (V) and Horizontal (H).

Above 1GHz:

The EUT is placed on a turntable 1.5 meters above the ground in the chamber, 3 meter away from the antenna. The maximal emission value is acquired by adjusting the antenna height, polarisation and turntable azimuth. Normally, the height range of antenna is 1 m to 4 m, the azimuth range of turntable is 0° to 360°, and the receive antenna has two polarizations Vertical (V) and Horizontal (H).

(a) Radiated Emission Test Set-Up, Frequency Below 30MHz

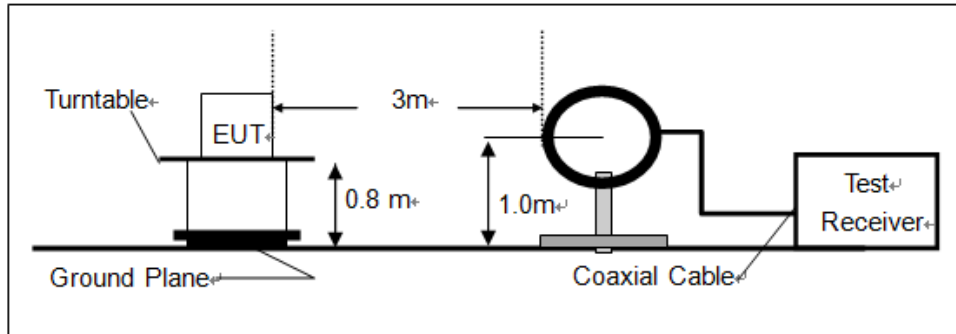

(b) Radiated Emission Test Set-Up, Frequency Below 1000MHz

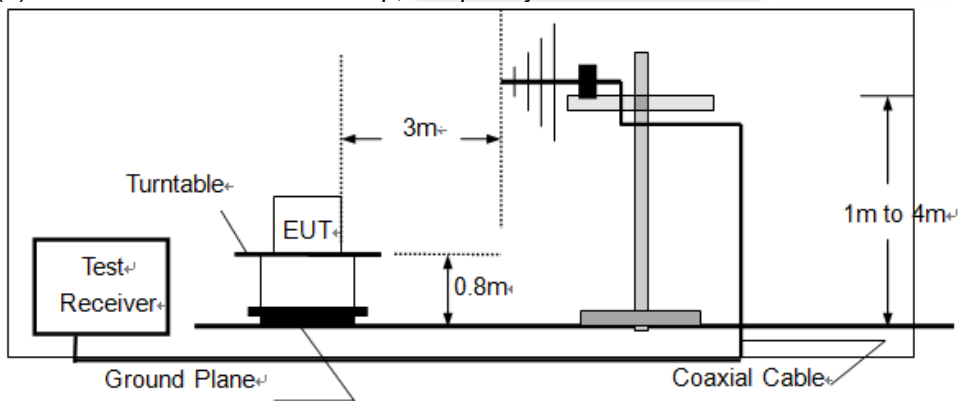

(c) Radiated Emission Test Set-Up, Frequency above 1000MHz

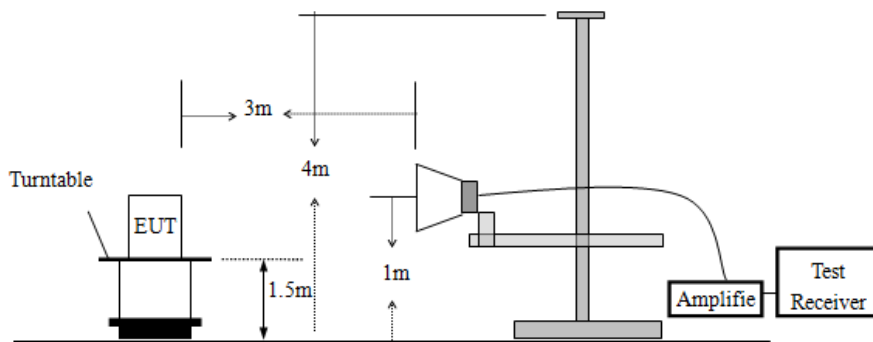

**7.3 CONDUCTED EMISSION TEST SETUP**

The mains cable of the EUT (maybe per AC/DC Adapter) must be connected to LISN. The LISN shall be placed 0.8 m from the boundary of EUT and bonded to a ground reference plane for LISN mounted on top of the ground reference plane. This distance is between the closest points of the LISN and the EUT. All other units of the EUT and associated equipment shall be at least 0.8m from the LISN.

Ground connections, where required for safety purposes, shall be connected to the reference ground point of the LISN and, where not otherwise provided or specified by the manufacturer, shall be of same length as the mains cable and run parallel to the mains connection at a separation distance of not more than 0.1 m.

According to the requirements in Section 13.1.4.1 of ANSI C63.10-2013 Conducted emissions from the EUT measured in the frequency range between 0.15 MHz and 30 MHz using CISPR Quasi-Peak and average detector mode.

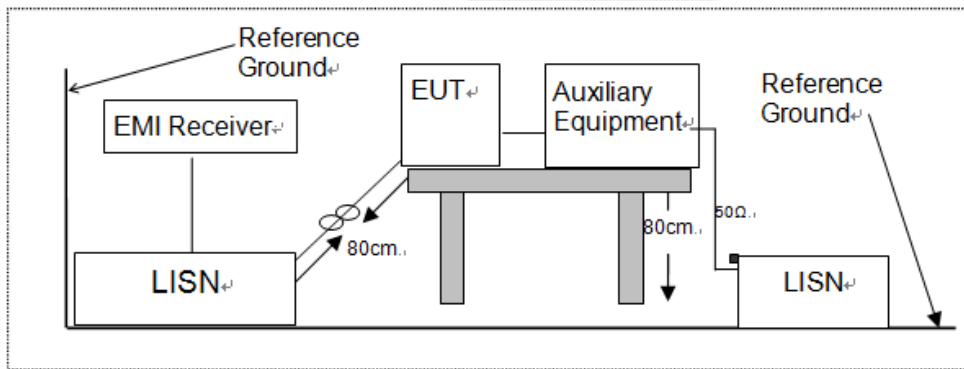

#### 7.4 BLOCK DIAGRAM CONFIGURATION OF TEST SYSTEM

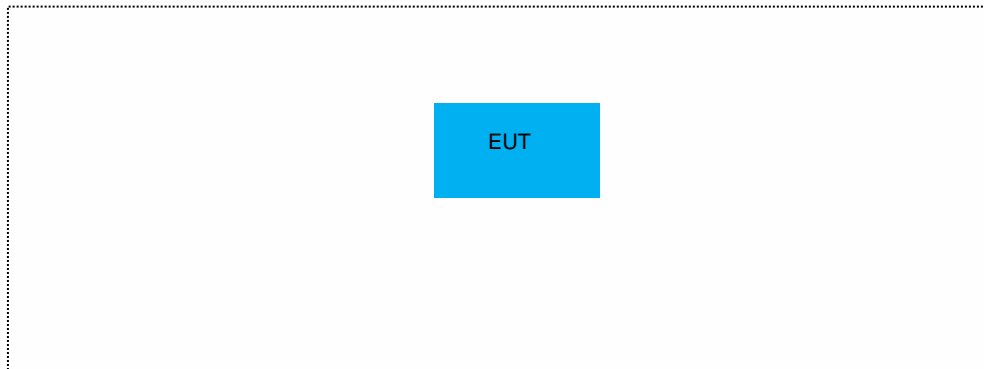

#### 7.5 SUPPORT EQUIPMENT

EUT Cable List and Details			
Cable Description	Length (m)	Shielded/Unshielded	With / Without Ferrite
/	/	/	/

Auxiliary Cable List and Details			
Cable Description	Length (m)	Shielded/Unshielded	With / Without Ferrite
/	/	/	/

Auxiliary Equipment List and Details			
Description	Manufacturer	Model	Serial Number
/	/	/	/

**Notes:**

1. All the equipment/cables were placed in the worst-case configuration to maximize the emission during the test.
2. Grounding was established in accordance with the manufacturer's requirements and conditions for the intended use.
3. Unless otherwise denoted as EUT in [Remark] column, device(s) used in tested system is a support equipment

## 8 TEST REQUIREMENTS

### 8.1 CARRIER OUTPUT POWER

#### 8.1.1 Applicable Standard

According to FCC Part 95.567, FCC Part 2.1046

#### 8.1.2 Conformance Limit

Each FRS transmitter type must be designed such that the effective radiated power (ERP) on channels 8 through 14 does not exceed 0.5 Watts and the ERP on channels 1 through 7 and 15 through 22 does not exceed 2.0 Watts.

#### 8.1.3 Test Configuration

Test according to clause 7.2 radio frequency test setup

#### 8.1.4 Test Procedure

Compliance with these rules is based on the use of measurement instrumentation employing a resolution bandwidth of 100 kHz or greater. In the 1 MHz bands immediately outside and adjacent to the frequency block a resolution bandwidth of at least one percent of the emission bandwidth of the fundamental emission of the transmitter may be employed. A narrower resolution bandwidth is permitted in all cases to improve measurement accuracy provided the measured power is integrated over the full required measurement bandwidth (i.e. 100 kHz or 1 percent of emission bandwidth, as specified). The emission bandwidth is defined as the width of the signal between two points, one below the carrier center frequency and one above the carrier center frequency, outside of which all emissions are attenuated at least 26 dB below the transmitter power.

then the following procedure can be used to determine spurious emission

- a) RBW = 1 MHz for  $f \geq 1$  GHz(1GHz to 25GHz), 100 kHz for  $f < 1$  GHz(30MHz to 1GHz), 200Hz for  $f < 150$ KHz(9KHz to 150KHz), 9KHz for  $f < 30$ MHz(150KHz to 30KHz)
- b) Set VBW  $\geq 3 \times$  RBW.
- c) Set span wide enough to fully capture the emission being measured
- d) Sweep time = auto couple.
- e) Detector = peak.
- f) Ensure that the number of measurement points  $\geq$  span/RBW.
- g) Trace mode = max hold.
- h) Allow trace to fully stabilize.
- i) Use the peak marker function to determine the peak amplitude level.

Step1. The EUT was placed on a rotatable wooden table with 0.8 meter above ground.

Step2. The EUT was set 3 meters from the receiving antenna, which was mounted on the antenna tower.

Step3. The table was rotated 360 degrees to determine the position of the highest spurious emission.

Step4. The height of the receiving antenna is varied between one meter and four meters to search the maximum spurious emission for both horizontal and vertical polarizations.

Step5. Make the measurement with the spectrum analyzer's RBW , VBW , taking the record of maximum spurious emission.

Step6. A horn antenna was substituted in place of the EUT and was driven by a signal generator.

Step7. Tune the output power of signal generator to the same emission level with EUT maximum spurious emission.

Step8. Taking the record of output power at antenna port.

Step9. Repeat step 7 to step 8 for another polarization.

Step10. Emission level (dBm) = output power + substitution Gain. Test Results

#### 8.1.5 Test Results

Temperature:	26° C
Relative Humidity:	54%
ATM Pressure:	1011 mbar



Operation Mode	Antenna Polarization	Channel Frequency (MHz)	Measured ERP (dBm)	Measured ERP(W)	Limit (W)	Verdict
TX-FRS	H	462.5625	1.40	0.001	2	PASS
	V	462.5625	11.63	0.015	2	PASS



## 8.2 99% OCCUPIED BANDWIDTH & 26DB BANDWIDTH

### 8.2.1 Applicable Standard

According to FCC Part 95.573, FCC Part 2.1049

### 8.2.2 Conformance Limit

Each FRS transmitter type must be designed such that the occupied bandwidth does not exceed 12.5 kHz.

### 8.2.3 Test Configuration

Test according to clause 7.1 radio frequency test setup 2

### 8.2.4 Test Procedure

- a) The RF output of the transmitter was connected to the input of the spectrum analyzer through sufficient attenuation.
- b) The signal is modulated with 1 kHz audio signal as necessary levels.
- c) Spectrum set as follow:  
Centre frequency = the nominal EUT channel center frequency,  
The frequency span for the spectrum analyzer shall be set wide enough to capture all modulation products including the emission skirts (typically a span of 1.5 × OBW is sufficient)  
RBW = 1% to 5% of the anticipated OBW, VBW ≥ 3 × RBW, Sweep = auto,  
Detector function = peak, Trace = max hold
- d) Set 99% Occupied Bandwidth and 26dB Bandwidth
- e) Then the mask plots were reported.

### 8.2.5 Test Results

Temperature:	26° C
Relative Humidity:	54%
ATM Pressure:	1011 mbar

Test Channel	Frequency (MHz)	Modulation Type	-26dB Bandwidth (kHz)	99% Bandwidth (kHz)	Limit (kHz)
TX-FRS	462.5625	FM	6.48	5.87	12.5

Test Model

99% & -26dB Bandwidth  
Channel : 462.5625MHz

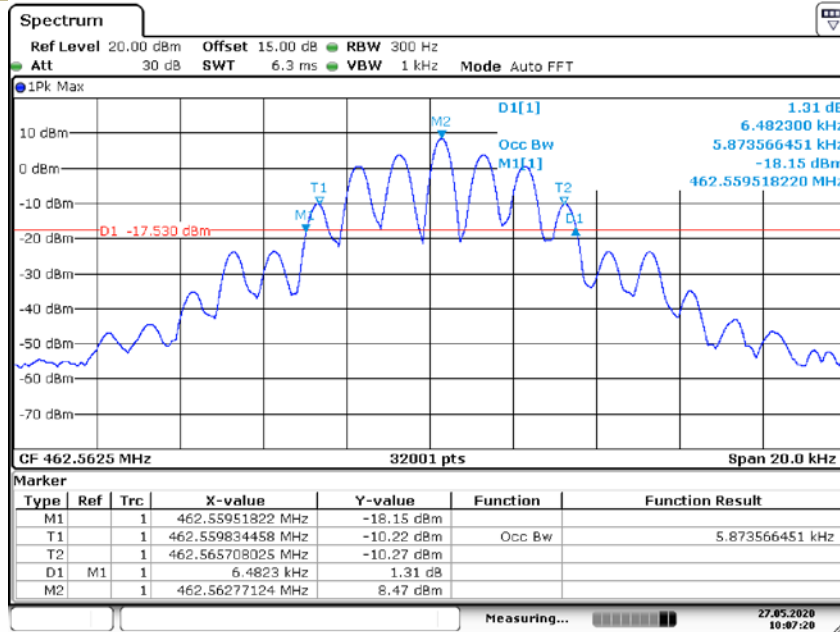

Date: 27.MAY.2020 10:07:20

### 8.3 EMISSION MASK

#### 8.3.1 Applicable Standard

According to FCC Part 95.579(a)(1)(2)(3), FCC Part 2.1049

#### 8.3.2 Conformance Limit

Each FRS transmitter type must be designed to satisfy the applicable unwanted emissions limits in this paragraph.

(a) Attenuation requirements. The power of unwanted emissions must be attenuated below the carrier power output in Watts (P) by at least:

(1) 25 dB (decibels) in the frequency band 6.25 kHz to 12.5 kHz removed from the channel center frequency.

(2) 35 dB in the frequency band 12.5 kHz to 31.25 kHz removed from the channel center frequency.

(3)  $43 + 10 \log (P)$  dB in any frequency band removed from the channel center frequency by more than 31.25 kHz.

#### 8.3.3 Test Configuration

Test according to clause 7.1 radio frequency test setup 2

#### 8.3.4 Test Procedure

This procedure shall be used emission mask was used to demonstrate compliance Spectrum set as follow:

Centre frequency = fundamental frequency, span=120kHz for 12.5kHz channel spacing,

RBW=100Hz, VBW=1000Hz, Sweep = auto,

Detector function = peak, Trace = max hold

Key the transmitter, and set the level of the unmodulated carrier to a full scale reference line. This is the 0dB reference for the measurement.

Apply Input Modulation Signal to EUT according to Section 3.4

Measure and record the results in the test report.

#### 8.3.5 Test Results

Temperature:	26° C
Relative Humidity:	54%
ATM Pressure:	1011 mbar

Test Model Emission mask  
FM  
Channel : 462.5625MHz

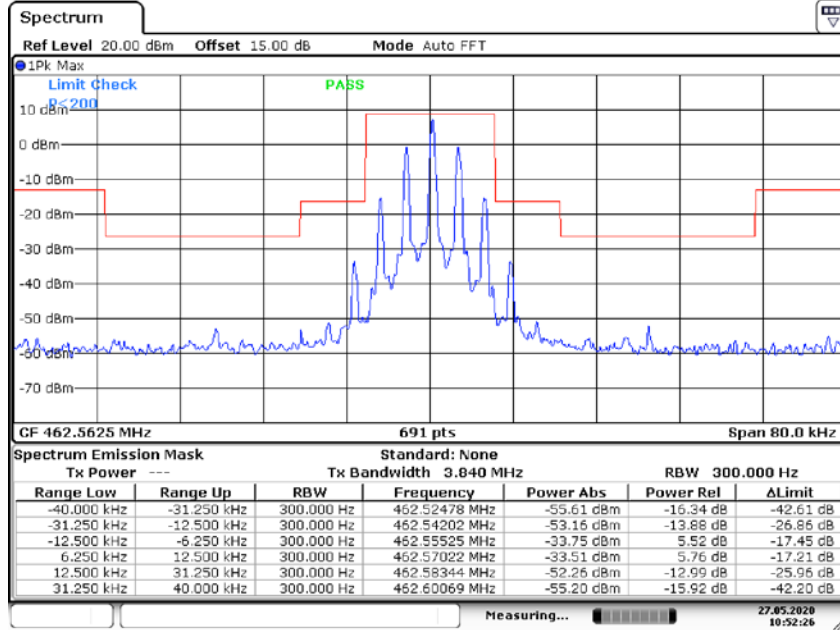

Date: 27.MAY.2020 10:52:27



## 8.4 MODULATION LIMIT

### 8.4.1 Applicable Standard

According to FCC Part 95.575, FCC Part 2.1047(b)

### 8.4.2 Conformance Limit

Each FRS transmitter type must be designed such that the peak frequency deviation does not exceed 2.5 kHz, and the highest audio frequency contributing substantially to modulation must not exceed 3.125 kHz.

### 8.4.3 Test Configuration

Test according to clause 7.1 radio frequency test setup 2

### 8.4.4 Test Procedure

The modulation was connected to the spectrum analyzer

- 1) Adjust the transmitter per the manufacturer's procedure for full rated system deviation.
- 2) Set the test receiver to measure peak positive deviation. Set the audio bandwidth for  $\leq 0.25$  Hz to  $\geq 15,000$  Hz. Turn the de-emphasis function off.
- 3) Apply Input Modulation Signal to EUT according to Section 3.4 and vary the input level from  $-20$  to  $+20$ dB.
- 4) Measure both the instantaneous and steady-state deviation at and after the time of increasing the audio input level

### 8.4.5 Test Results

Temperature:	26° C
Relative Humidity:	54%
ATM Pressure:	1011 mbar

### MODULATION LIMITING

Carrier Frequency: 462.5625MHz, Channel Separation=12.5 kHz

Audio Frequency (Hz)	Instantaneous		Steady-state		Limit [KHz]
	Deviation (@+20dB) [KHz]	Deviation (@-20dB) [KHz]	Deviation (@+20dB) [KHz]	Deviation (@-20dB) [KHz]	
300	0.89	0.05	0.67	0.05	2.5
400	1.21	0.09	0.89	0.07	2.5
500	1.35	0.11	1.19	0.11	2.5
600	1.42	0.13	1.27	0.15	2.5
700	1.59	0.15	1.35	0.21	2.5
800	1.78	0.19	1.46	0.29	2.5
900	1.83	0.25	1.59	0.25	2.5
1000	1.88	0.27	1.63	0.29	2.5
1200	1.89	0.35	1.71	0.31	2.5
1400	1.93	0.37	1.85	0.29	2.5
1600	1.95	0.4	1.89	0.31	2.5
1800	2.01	0.43	1.87	0.28	2.5
2000	2.05	0.45	1.95	0.3	2.5
2200	2.09	0.51	2.05	0.37	2.5
2400	2.13	0.55	2.07	0.35	2.5
2600	2.07	0.57	2.03	0.39	2.5
2800	2.11	0.59	1.95	0.43	2.5
3000	2.05	0.55	1.91	0.45	2.5

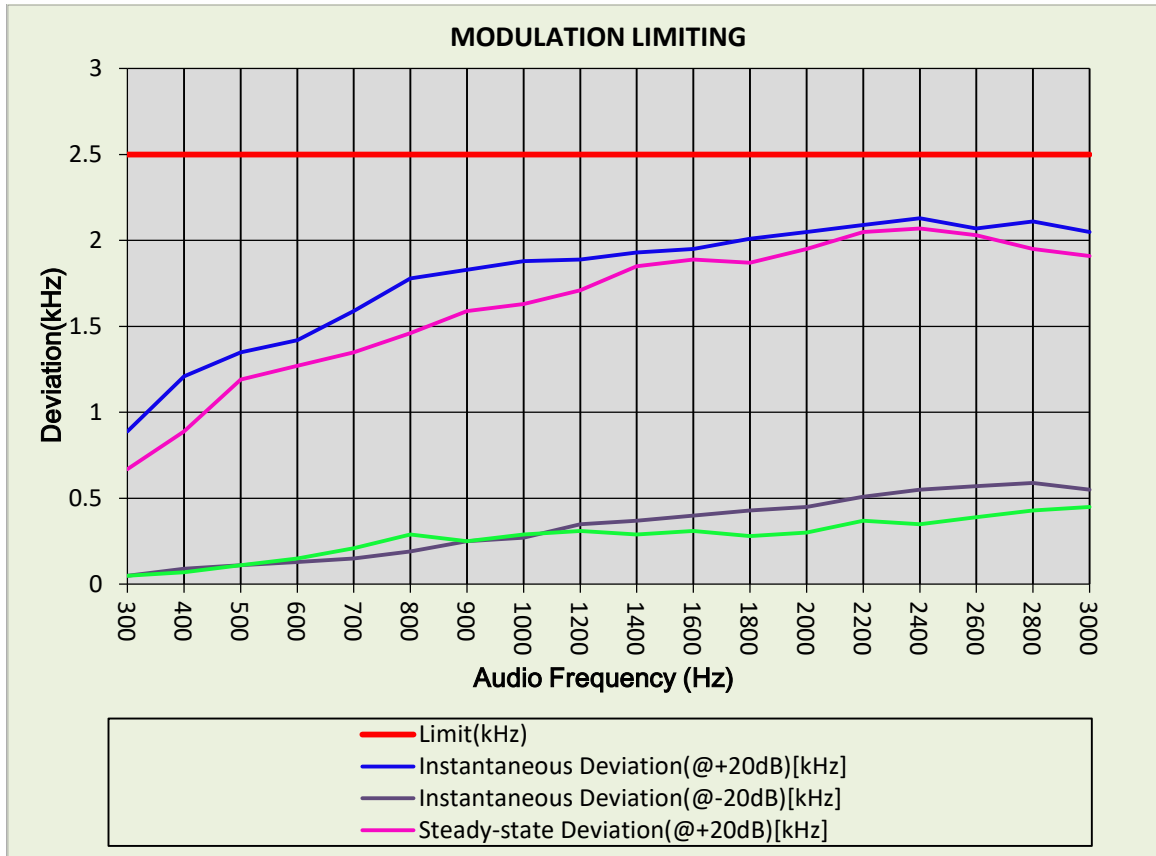



## 8.5 AUDIO FREQUENCY RESPONSE

### 8.5.1 Applicable Standard

According to FCC Part 95.575, FCC Part 2.1047(a)

### 8.5.2 Conformance Limit

Each FRS transmitter type must be designed such that the peak frequency deviation does not exceed 2.5 kHz, and the highest audio frequency contributing substantially to modulation must not exceed 3.125 kHz.

Voice modulated communication equipment. A curve or equivalent data showing the frequency response of the audio modulating circuit over a range of 100 to 5000 Hz shall be submitted. For equipment required to have an audio low-pass filter, a curve showing the frequency response of the filter, or of all circuitry installed between the modulation limiter and the modulated stage shall be submitted.

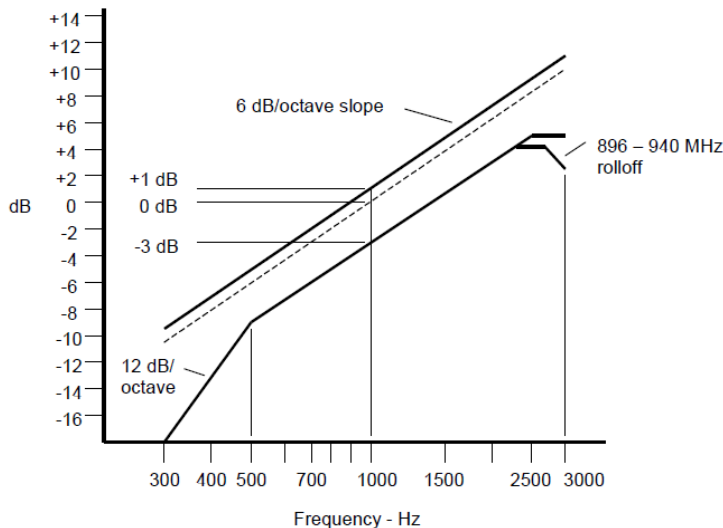

### 8.5.3 Test Configuration

Test according to clause 7.1 radio frequency test setup 2

### 8.5.4 Test Procedure

The Audio Frequency Response was connected to the spectrum analyzer

Set the test receiver to measure peak positive deviation. Set the audio bandwidth for 50 Hz to 15,000 Hz. Turn the de-emphasis function off.

Set the DMM to measure rms voltage.

Adjust the transmitter per the manufacturer's procedure for full rated system deviation.

Apply Input Modulation Signal to EUT according to Section 3.4

Set the test receiver to measure rms deviation and record the deviation reading.

Record the DMM reading as VREF

Set the audio frequency generator to the desired test frequency between 300 Hz and 3000 Hz.

Vary the audio frequency generator output level until the deviation reading that was recorded in step 6) is obtained.

Record the DMM reading as VFREQ

Calculate the audio frequency response at the present frequency as:

audio frequency response =  $20 \log_{10} (VFREQ/VREF)$ .

## 8.5.5 Test Results

Temperature:	26° C
Relative Humidity:	54%
ATM Pressure:	1011 mbar

**Audio Frequency Response**

Carrier Frequency: 462.5625MHz, Channel Separation=12.5 kHz

Audio Frequency (Hz)	Response Attenuation (dB)
300	0.1
400	0.2
500	0.24
600	0.26
700	0.3
800	0.35
900	0.4
1000	0.5
1200	0.54
1400	0.56
1600	0.7
1800	0.8
2000	0.9
2200	1.0
2400	1.2
2600	1.25
2800	1.3
3000	1.4

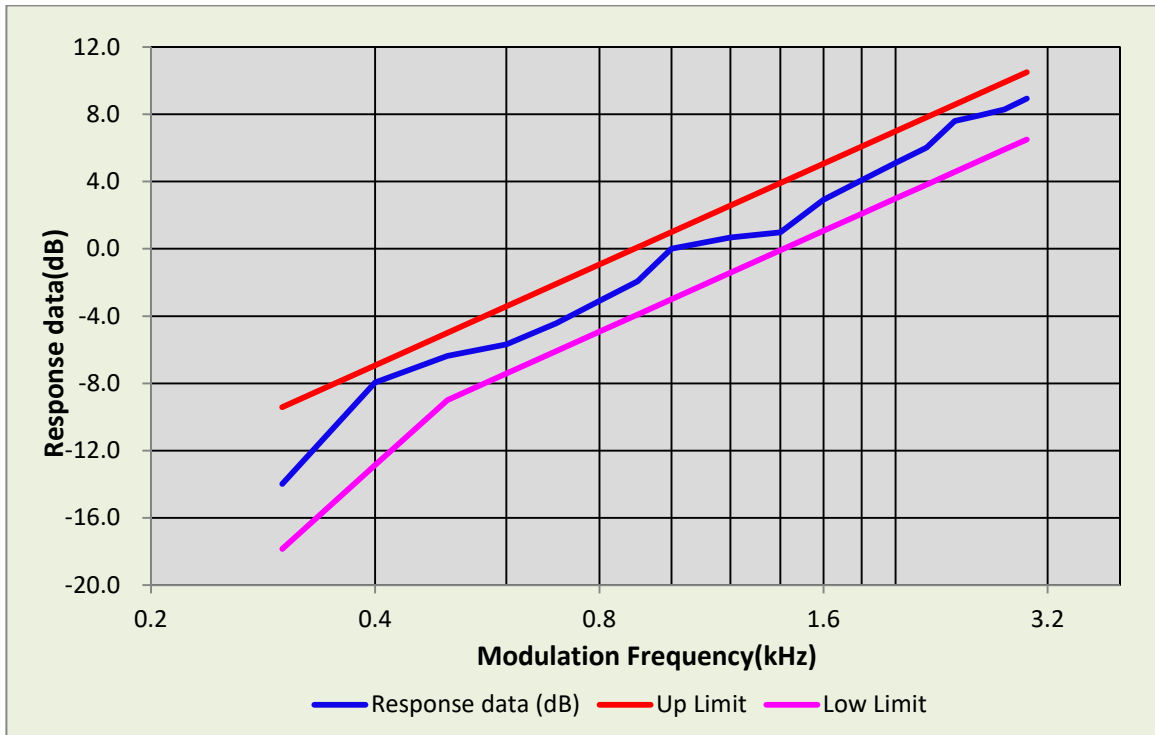

## 8.6 FREQUENCY STABILITY

### 8.6.1 Applicable Standard

According to FCC Part 95.565, FCC Part 2.1055

### 8.6.2 Conformance Limit

Each FRS transmitter type must be designed such that the carrier frequencies remain within  $\pm 2.5$  parts-per-million of the channel center frequencies specified in §95.563 during normal operating conditions.

### 8.6.3 Test Configuration

Test according to clause 7.1 radio frequency test setup 1

### 8.6.4 Test Procedure

Frequency Stability vs. Temperature: The equipment under test was connected to an external DC power supply and the RF output was connected to a frequency counter via feed-through attenuators. The EUT was placed inside the temperature chamber. The DC leads and RF output cable exited the chamber through an opening made for the purpose.

After the temperature stabilized for approximately 20 minutes, the frequency output was recorded from the counter.

### 8.6.5 Test Results

Reference Frequency: 462.5625 MHz, Limit: $\pm 2.5$ ppm, 12.5 kHz			
Test Environment		Frequency Measure with Time Elapsed	
Temperature ( $^{\circ}\text{C}$ )	Power Supplied (VDC)	Measured Frequency (MHz)	Frequency Error (ppm)
Frequency Stability versus Input Temperature			
50	6.0	462.5628	0.65
40	6.0	462.5630	1.08
30	6.0	462.5627	0.43
20	6.0	462.5628	0.65
10	6.0	462.5631	1.30
0	6.0	462.5629	0.86
-10	6.0	462.5626	0.22
-20	6.0	462.5629	0.86
Frequency Stability versus Input Voltage			
20	5.1	462.5633	1.73
20	6.9	462.5631	1.30

## 8.7 RADIATED SPURIOUS EMISSION

### 8.7.1 Applicable Standard

According to FCC Part 95.579(a)(3)

### 8.7.2 Conformance Limit

Each FRS transmitter type must be designed to satisfy the applicable unwanted emissions limits in this paragraph.

(a) Attenuation requirements. The power of unwanted emissions must be attenuated below the carrier power output in Watts (P) by at least:

(1) 25 dB (decibels) in the frequency band 6.25 kHz to 12.5 kHz removed from the channel center frequency.

(2) 35 dB in the frequency band 12.5 kHz to 31.25 kHz removed from the channel center frequency.

(3)  $43 + 10 \log (P)$  dB in any frequency band removed from the channel center frequency by more than 31.25 kHz.

### 8.7.3 Test Configuration

Test according to clause 7.2 radio frequency test setup

### 8.7.4 Test Procedure

The setup of EUT is according with per TIA/EIA Standard 603 and ANSI C63.4-2014 measurement procedure.

The measurement antenna was placed at a distance of 3 meters from the EUT. During the tests, the antenna height and polarization as well as EUT azimuth were varied in order to identify the maximum level of emissions from the EUT. The test was performed by placing the EUT on 3-orthogonal axis.

The frequency range up to tenth harmonic of the fundamental frequency was investigated.

Remove the EUT and replace it with substitution antenna. A signal generator was connected to the substitution antenna by a non-radiating cable. The absolute levels of the spurious emissions were measured by the substitution.

Spurious attenuation limit in dB =  $43 + 10 \log_{10}(\text{power in Watts})$

### 8.7.5 Test Results

Temperature:	26° C
Relative Humidity:	54%
ATM Pressure:	1011 mbar

#### ■ Spurious Emission below 30MHz(9KHz to 30MHz)

Freq. (MHz)	Ant. Pol. H/V	Emission Level(dBuV/m)		Limit 3m(dBuV/m)		Over(dB)	
		PK	AV	PK	AV	PK	AV
--	--	--	--	--	--	--	--

Note: the amplitude of spurious emission that is attenuated by more than 20dB below the permissible limit has no need to be reported.

Distance extrapolation factor =  $40 \log(\text{Specific distance/ test distance})$  (dB);

Limit line = Specific limits (dBuV) + distance extrapolation factor

## Emissions In the Spurious Domain below 1GHz.

Operation Mode:		<input checked="" type="checkbox"/> TX-FRS			
Operation frequency:		<input checked="" type="checkbox"/> 462.5625MHz		Temperature: 25°C	
Humidity:		55 % RH		Tested by: XW	
Frequency (MHz)	Antenna Polarization		Emission level (dBm)	Limit (dBm)	Verdict
67.00	<input checked="" type="checkbox"/> V	<input type="checkbox"/> conducted	-57.59	-13.00	PASS
145.86			-56.90	-13.00	PASS
432.76			-49.75	-13.00	PASS
505.15			-45.80	-13.00	PASS
846.94			-40.63	-13.00	PASS
925.35			-20.50	-13.00	PASS
58.31	<input checked="" type="checkbox"/> H		-55.84	-13.00	PASS
368.92			-53.26	-13.00	PASS
713.26			-45.82	-13.00	PASS
760.04			-42.19	-13.00	PASS
846.94			-39.55	-13.00	PASS
925.35			-40.25	-13.00	PASS

## Emissions In the Spurious Domain above 1GHz.

Operation Mode:		<input checked="" type="checkbox"/> TX-FRS			
Operation frequency:		<input checked="" type="checkbox"/> 462.5625MHz		Temperature: 25°C	
Humidity:		55 % RH		Tested by: XW	
Frequency (MHz)	Antenna Polarization		Emission level (dBm)	Limit (dBm)	Verdict
1387.65	<input checked="" type="checkbox"/> V	<input type="checkbox"/> conducted	-44.54	-13.00	PASS
2312.89			-32.23	-13.00	PASS
3237.79			-27.51	-13.00	PASS
4163.11			-21.91	-13.00	PASS
5088.47			-21.06	-13.00	PASS
6013.24			-31.40	-13.00	PASS
1387.65	<input checked="" type="checkbox"/> H		-48.08	-13.00	PASS
2312.60			-34.11	-13.00	PASS
3237.79			-23.68	-13.00	PASS
4163.11			-26.22	-13.00	PASS
5088.47			-24.08	-13.00	PASS
6013.24			-34.61	-13.00	PASS

Detail of factor for radiated emission

Frequency(MHz)	Ant_F(dB)	Cab_L(dB)	Preamp(dB)	Correct Factor(dB)
0.009	20.6	0.03	\	20.63
0.15	20.7	0.1	\	20.8
1	20.9	0.15	\	21.05
10	20.1	0.28	\	20.38
30	18.8	0.45	\	19.25
30	11.7	0.62	27.9	-15.58
100	12.5	1.02	27.8	-14.28
300	12.9	1.91	27.5	-12.69
600	19.2	2.92	27	-4.88
800	21.1	3.54	26.6	-1.96
1000	22.3	4.17	26.2	0.27
1000	25.6	1.76	41.4	-14.04
3000	28.9	3.27	43.2	-11.03
5000	31.1	4.2	44.6	-9.3
8000	36.2	5.95	44.7	-2.55
10000	38.4	6.3	43.9	0.8
12000	38.5	7.14	42.3	3.34
15000	40.2	8.15	41.4	6.95
18000	45.4	9.02	41.3	13.12
18000	37.9	1.81	47.9	-8.19
21000	37.9	1.95	48.7	-8.85
25000	39.3	2.01	42.8	-1.49
28000	39.6	2.16	46.0	-4.24
31000	41.2	2.24	44.5	-1.06
34000	41.5	2.29	46.6	-2.81
37000	43.8	2.30	46.4	-0.3
40000	43.2	2.50	42.2	3.5