

---

# FCC Test Report

---

Report No.: AGC00203220903FE04

**FCC ID** : 2AE67-CR2714A  
**APPLICATION PURPOSE** : Original Equipment  
**PRODUCT DESIGNATION** : SLING AND SING KARAOKE  
**BRAND NAME** : **GROOVE**<sup>®</sup>  
**MODEL NAME** : CR-2714A  
**APPLICANT** : Bulk Unlimited Corp  
**DATE OF ISSUE** : Sep. 28, 2022  
**STANDARD(S)** : FCC Part 15.236  
**REPORT VERSION** : V1.0

Attestation of Global Compliance (Shenzhen) Co., Ltd



Any report having not been signed by authorized approver, or having been altered without authorization, or having not been stamped by the "Dedicated Testing/Inspection Stamp" is deemed to be invalid. Copying or excerpting portion of, or altering the content of the report is not permitted without the written authorization of AGC. The test results presented in the report apply only to the tested sample. Any objections to report issued by AGC should be submitted to AGC within 15days after the issuance of the test report. Further enquiry of validity or verification of the test report should be addressed to AGC by [agc01@agccert.com](mailto:agc01@agccert.com).

Attestation of Global Compliance(Shenzhen)Co., Ltd  
Attestation of Global Compliance(Shenzhen)Std & Tech Co., Ltd  
Tel: +86-755 2523 4088 E-mail: [agc@agccert.com](mailto:agc@agccert.com) Web: <http://www.agccert.com/>



**Report Revise Record**

Report Version	Revise Time	Issued Date	Valid Version	Notes
V1.0	/	Sep. 28, 2022	Valid	Initial Release

Any report having not been signed by authorized approver, or having been altered without authorization, or having not been stamped by the "Dedicated Testing/Inspection Stamp" is deemed to be invalid. Copying or excerpting portion of, or altering the content of the report is not permitted without the written authorization of AGC. The test results presented in the report apply only to the tested sample. Any objections to report issued by AGC should be submitted to AGC within 15days after the issuance of the test report. Further enquiry of validity or verification of the test report should be addressed to AGC by [agc01@agccert.com](mailto:agc01@agccert.com).

**TABLE OF CONTENTS**

**1. VERIFICATION OF CONFORMITY..... 5**

**2. GENERAL INFORMATION ..... 6**

    2.1. PRODUCT DESCRIPTION ..... 6

    2.2. TEST METHODOLOGY ..... 7

    2.3. SPECIAL ACCESSORIES ..... 7

    2.4. EQUIPMENT MODIFICATIONS ..... 7

    2.5. ANTENNA REQUIREMENT..... 7

**3. MEASUREMENT UNCERTAINTY ..... 8**

**4. DESCRIPTION OF TEST MODES ..... 9**

**5. SYSTEM TEST CONFIGURATION ..... 10**

    5.1. CONFIGURATION OF EUT SYSTEM..... 10

    5.2 EQUIPMENT USED IN TESTED SYSTEM..... 10

    5.3. SUMMARY OF TEST RESULTS ..... 10

**6. TEST FACILITY .....11**

**7. OUPUT POWER ..... 12**

    7.1. TEST LIMIT ..... 12

    7.2. MEASUREMENT PROCEDURE ..... 12

    7.3. TEST SETUP..... 13

    7.4. TEST RESULT..... 14

**8. OCCUPIED BANDWIDTH..... 15**

    8.1. TEST LIMIT ..... 15

    8.2. MEASUREMENT PROCEDURE ..... 15

    8.3. TEST SET-UP..... 15

    8.4. MEASUREMENT RESULTS ..... 15

**9. FREQUENCY STABILITY ..... 18**

    9.1. TEST LIMIT ..... 18

    9.2. MEASUREMENT PROCEDURE ..... 18

    9.3. TEST SET-UP..... 18

    9.4. TEST RESULT..... 19

**10. EMISSIONS WITHIN THE BAND AND OUTSIDE THE BAND..... 21**

Any report having not been signed by authorized approver, or having been altered without authorization, or having not been stamped by the “Dedicated Testing/Inspection Stamp” is deemed to be invalid. Copying or excerpting portion of, or altering the content of the report is not permitted without the written authorization of AGC. The test results presented in the report apply only to the tested sample. Any objections to report issued by AGC should be submitted to AGC within 15days after the issuance of the test report. Further enquiry of validity or verification of the test report should be addressed to AGC by [agc01@agccert.com](mailto:agc01@agccert.com).

10.1. TEST LIMIT .....	21
10.2. MEASUREMENT PROCEDURE .....	21
10.3. TEST SETUP .....	22
10.4. TEST RESULT.....	23
<b>11. LINE CONDUCTED EMISSION TEST .....</b>	<b>33</b>
11.1. LIMITS OF LINE CONDUCTED EMISSION TEST.....	33
11.2. BLOCK DIAGRAM OF LINE CONDUCTED EMISSION TEST .....	33
11.3. PRELIMINARY PROCEDURE OF LINE CONDUCTED EMISSION TEST .....	34
11.4. FINAL PROCEDURE OF LINE CONDUCTED EMISSION TEST.....	34
11.5. TEST RESULT OF LINE CONDUCTED EMISSION TEST .....	35
<b>APPENDIX A: PHOTOGRAPHS OF TEST SETUP .....</b>	<b>37</b>
<b>APPENDIX B: PHOTOGRAPHS OF EUT .....</b>	<b>37</b>



Any report having not been signed by authorized approver, or having been altered without authorization, or having not been stamped by the “Dedicated Testing/Inspection Stamp” is deemed to be invalid. Copying or excerpting portion of, or altering the content of the report is not permitted without the written authorization of AGC. The test results presented in the report apply only to the tested sample. Any objections to report issued by AGC should be submitted to AGC within 15days after the issuance of the test report. Further enquiry of validity or verification of the test report should be addressed to AGC by agc01@agccert.com.

### 1. VERIFICATION OF CONFORMITY

<b>Applicant</b>	Bulk Unlimited Corp
<b>Address</b>	801 Barton Springs Road, Austin, TX 78704, United States
<b>Manufacturer</b>	Bulk Unlimited Corp
<b>Address</b>	801 Barton Springs Road, Austin, TX 78704, United States
<b>Factory</b>	Bulk Unlimited Corp
<b>Address</b>	801 Barton Springs Road, Austin, TX 78704, United States
<b>Product Designation</b>	SLING AND SING KARAOKE
<b>Brand Name</b>	<b>CROOVE</b> <sup>®</sup>
<b>Test Model</b>	CR-2714A
<b>Date of receipt of test item</b>	Sep. 07, 2022
<b>Date of test</b>	Sep. 07, 2022 to Sep. 20, 2022
<b>Deviation</b>	No any deviation from the test method
<b>Condition of Test Sample</b>	Normal
<b>Test Result</b>	Pass
<b>Report Template</b>	AGCRT-US-LPAS/RF

We hereby certify that:

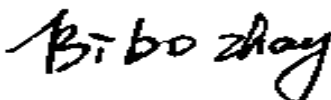
The above equipment was tested by Attestation of Global Compliance (Shenzhen) Co., Ltd. The test data, data evaluation, test procedures, and equipment configurations shown in this report were made in accordance with the procedures given in ANSI C63.10:2013 and the energy emitted by the sample EUT tested as described in this report is in compliance with radiated emission limits of FCC Part 15.236.

Prepared By	 <hr style="border: 0.5px solid black;"/>		Bibo Zhang (Project Engineer)	Sep. 28, 2022
Reviewed By	 <hr style="border: 0.5px solid black;"/>		Calvin Liu (Reviewer)	Sep. 28, 2022
Approved By	 <hr style="border: 0.5px solid black;"/>		Max Zhang (Authorized Officer)	Sep. 28, 2022

Any report having not been signed by authorized approver, or having been altered without authorization, or having not been stamped by the "Dedicated Testing/Inspection Stamp" is deemed to be invalid. Copying or excerpting portion of, or altering the content of the report is not permitted without the written authorization of AGC. The test results presented in the report apply only to the tested sample. Any objections to report issued by AGC should be submitted to AGC within 15days after the issuance of the test report. Further enquiry of validity or verification of the test report should be addressed to AGC by agc01@agccert.com.

## 2. GENERAL INFORMATION

### 2.1. PRODUCT DESCRIPTION

<b>Operation Frequency</b>	657MHz-663MHz
<b>Maximum Radiated Power</b>	6.326dBm
<b>EIRP</b>	6.836dBm
<b>Modulation</b>	FM
<b>Number of channels</b>	13 Channels
<b>Antenna Gain</b>	0.51dBi
<b>Antenna Designation</b>	PCB Antenna (Met 15.203 Antenna requirement)
<b>Hardware Version</b>	V1.0
<b>Software Version</b>	V1.0
<b>Power Supply</b>	DC 3.7V by battery or DC 5V by adapter

#### Channel list:

Channel Number	Frequency (MHz)	Channel Number	Frequency (MHz)
01	657 MHz	08	660.5 MHz
02	657.5 MHz	09	661 MHz
03	658 MHz	10	661.5 MHz
04	658.5 MHz	11	662 MHz
05	659 MHz	12	662.5 MHz
06	659.5 MHz	13	663 MHz
07	660 MHz		

Any report having not been signed by authorized approver, or having been altered without authorization, or having not been stamped by the "Dedicated Testing/Inspection Stamp" is deemed to be invalid. Copying or excerpting portion of, or altering the content of the report is not permitted without the written authorization of AGC. The test results presented in the report apply only to the tested sample. Any objections to report issued by AGC should be submitted to AGC within 15days after the issuance of the test report. Further enquiry of validity or verification of the test report should be addressed to AGC by [agc01@agccert.com](mailto:agc01@agccert.com).

## **2.2. TEST METHODOLOGY**

Both conducted and radiated testing was performed according to the procedures in ANSI C63.10 (2013). Radiated testing was performed at an antenna to EUT distance 3 meters.

## **2.3. SPECIAL ACCESSORIES**

Refer to section 5.2.

## **2.4. EQUIPMENT MODIFICATIONS**

Not available for this EUT intended for grant.

## **2.5. ANTENNA REQUIREMENT**

This intentional radiator is designed with a permanently attached antenna of an antenna to ensure that no antenna other than that furnished by the responsible party shall be used with the device.

For more information of the antenna, please refer to the APPENDIX B: PHOTOGRAPHS OF EUT.

### 3. MEASUREMENT UNCERTAINTY

The reported uncertainty of measurement  $y \pm U$ , where expanded uncertainty  $U$  is based on a standard uncertainty multiplied by a coverage factor of  $k=2$ , providing a level of confidence of approximately 95%.

Item	Measurement Uncertainty
Uncertainty of Conducted Emission for AC Port	$U_c = \pm 2.9$ dB
Uncertainty of Radiated Emission below 1GHz	$U_c = \pm 3.8$ dB
Uncertainty of Radiated Emission above 1GHz	$U_c = \pm 4.9$ dB
Uncertainty of total RF power, conducted	$U_c = \pm 0.8$ dB
Uncertainty of spurious emissions, conducted	$U_c = \pm 2.7$ %
Uncertainty of Occupied Channel Bandwidth	$U_c = \pm 2$ %

Any report having not been signed by authorized approver, or having been altered without authorization, or having not been stamped by the "Dedicated Testing/Inspection Stamp" is deemed to be invalid. Copying or excerpting portion of, or altering the content of the report is not permitted without the written authorization of AGC. The test results presented in the report apply only to the tested sample. Any objections to report issued by AGC should be submitted to AGC within 15days after the issuance of the test report. Further enquiry of validity or verification of the test report should be addressed to AGC by [agc01@agccert.com](mailto:agc01@agccert.com).



#### 4. DESCRIPTION OF TEST MODES

NO.	TEST MODE DESCRIPTION
1	TX mode at Low channel (CH01: 657MHz)
2	TX mode at Middle channel (CH07: 660MHz)
3	TX mode at High channel(CH13: 663MHz)

Note: 1. For Radiated Emission, 3axis were chosen for testing for each applicable mode.

2. For Conducted Test method, a temporary antenna connector is provided by the manufacture.

3. For battery operated equipment, the equipment tests are performed using a new battery.

## 5. SYSTEM TEST CONFIGURATION

### 5.1. CONFIGURATION OF EUT SYSTEM

Radiated Emission Configure:

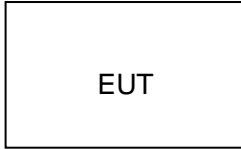

Conducted Emission Configure:

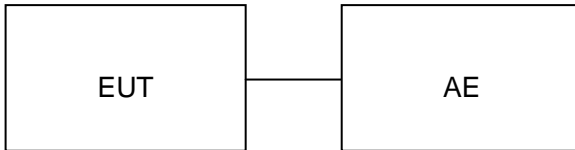

### 5.2 EQUIPMENT USED IN TESTED SYSTEM

Item	Equipment	Model No.	ID or Specification	Remark
1	SLING AND SING KARAOKE	CR-2714A	2AE67-CR2714A	EUT
2	Charger line	N/A	0.8m unshielded	Accessories
3	Adapter	TPA-23A050200CU01	DC 5V	AE

### 5.3. SUMMARY OF TEST RESULTS

FCC RULES	DESCRIPTION OF TEST	RESULT
§15.203	Antenna requirement	Compliant
§15.236(d)(1)	Maximum radiated power	Compliant
§15.236(f)(2)	Occupied bandwidth	Compliant
§15.236(f)(3)	Frequency stability	Compliant
§15.236(g)	Emissions within the band	Compliant
§15.236(g)	Emissions outside of this band	Compliant
15.207	Line Conducted Emission	Compliant

Any report having not been signed by authorized approver, or having been altered without authorization, or having not been stamped by the "Dedicated Testing/Inspection Stamp" is deemed to be invalid. Copying or excerpting portion of, or altering the content of the report is not permitted without the written authorization of AGC. The test results presented in the report apply only to the tested sample. Any objections to report issued by AGC should be submitted to AGC within 15days after the issuance of the test report. Further enquiry of validity or verification of the test report should be addressed to AGC by agc01@agccert.com.

## 6. TEST FACILITY

<b>Test Site</b>	Attestation of Global Compliance (Shenzhen) Co., Ltd
<b>Location</b>	1-2/F, Building 19, Junfeng Industrial Park, Chongqing Road, Heping Community, Fuhai Street, Bao'an District, Shenzhen, Guangdong, China
<b>Designation Number</b>	CN1259
<b>FCC Test Firm Registration Number</b>	975832
<b>A2LA Cert. No.</b>	5054.02
<b>Description</b>	Attestation of Global Compliance (Shenzhen) Co., Ltd is accredited by A2LA

### TEST EQUIPMENT OF CONDUCTED EMISSION TEST

Equipment	Manufacturer	Model	S/N	Cal. Date	Cal. Due
Test Receiver	R&S	ESPI	101206	Mar. 28, 2022	Mar. 27, 2023
Artificial power network	R&S	ESH2-Z5	100086	Jun. 08, 2022	Jun. 07, 2023
Test Software	FARA	EZ-EMC	Ver. AGC-CON03A1	N/A	N/A

### TEST EQUIPMENT OF RADIATED EMISSION TEST

Equipment	Manufacturer	Model	S/N	Cal. Date	Cal. Due
Test Receiver	R&S	ESCI	10096	Mar. 28, 2022	Mar. 27, 2023
Signal Analyzer	Aglient	N9020A	MY52090123	Aug. 04, 2022	Aug. 03, 2023
Attenuator	ZHINAN	E-002	N/A	Aug. 04, 2022	Aug. 03, 2024
Double-Ridged Waveguide Horn	ETS	3117	00154520	Sep. 06, 2021	Sep. 05, 2023
Double-Ridged Waveguide Horn	ETS	3117	00034609	Apr. 23, 2021	Apr. 22, 2023
Active Loop Antenna (9K-30Mhz)	ZHINAN	ZN30900C	18051	Mar. 12, 2022	Mar. 11, 2024
Preamplifier Assembly	ETS	3117PA	00225134	Sep. 03, 2020	Sep. 02, 2022
Preamplifier Assembly	ETS	3117PA	00225134	Sep. 01, 2022	Sep. 02, 2024
Wideband Antenna	SCHWARZBECK	VULB9168	VULB9168-494	Jan. 08, 2021	Jan. 07, 2023
Wireless communication tester	HP	8920B	US35010161	Aug. 03, 2022	Aug. 02, 2023
Test software	Tonscend	JS32-RE	Ver. 2.5	N/A	N/A

Any report having not been signed by authorized approver, or having been altered without authorization, or having not been stamped by the "Dedicated Testing/Inspection Stamp" is deemed to be invalid. Copying or excerpting portion of, or altering the content of the report is not permitted without the written authorization of AGC. The test results presented in the report apply only to the tested sample. Any objections to report issued by AGC should be submitted to AGC within 15days after the issuance of the test report. Further enquiry of validity or verification of the test report should be addressed to AGC by agc01@agccert.com.

## 7. OUTPUT POWER

### 7.1. TEST LIMIT

The power may not exceed the following values.

657-663MHz bands: 20 mW EIRP

### 7.2. MEASUREMENT PROCEDURE

#### EIRP Test Method

1. The EUT was placed on the top of the turntable 0.8 meter above ground. The phase center of the receiving antenna mounted on the top of a height-variable antenna tower was placed 3 meters far away from the turntable.
  2. Power on the EUT and all the supporting units. The turntable was rotated by 360 degrees to determine the position of the highest radiation.
  3. The height of the broadband receiving antenna was varied between one meter and four meters above ground to find the maximum emissions field strength of both horizontal and vertical polarization.
  4. For each suspected emission, the antenna tower was scan (from 1 M to 4 M) and then the turntable was rotated (from 0 degree to 360 degrees) to find the maximum reading.
  5. Set the test-receiver system to Peak or CISPR quasi-peak Detect Function with specified bandwidth under Maximum Hold Mode.
  6.  $EIRP [dBm] = E[dB(\mu V)/m] - 95.3$
- 4.7dB shall be added as an upper bound on the field strength that would be observed on a test range with a ground plane for frequencies between 30MHz and 1000MHz, or an additional 6dB shall be added for frequencies below 30 MHz.

#### Conducted Power Test Method

1. Connect EUT RF output port to the Spectrum Analyzer through an RF attenuator
2.  $RBW \geq OBW$ .
3.  $VBW \geq 3 \times RBW$ .
4.  $Span \geq 2 \times OBW$ .
5.  $Sweep\ time \geq 10 \times (\text{number of points in sweep}) \times (\text{transmission symbol period})$
6. Detector function: Peak.
7. Trace: Max hold.
8. Allow trace to stabilize. Use the marker-to-peak function to set the marker to the peak of the emission. The indicated level is the peak output power, after any corrections for external attenuators and cables.

### 7.3. TEST SETUP

EIRP Test Method

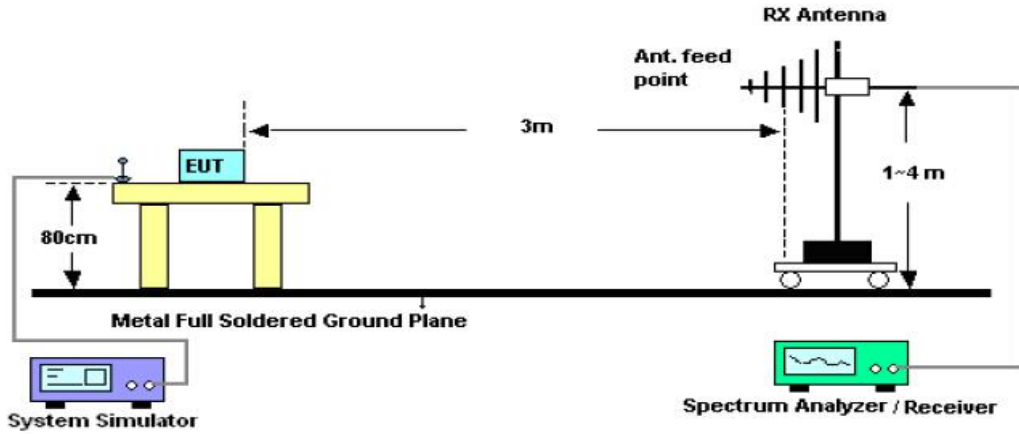

Conducted Power Test Method

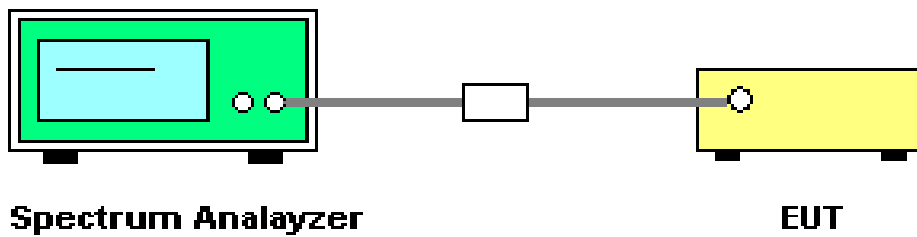

Any report having not been signed by authorized approver, or having been altered without authorization, or having not been stamped by the “Dedicated Testing/Inspection Stamp” is deemed to be invalid. Copying or excerpting portion of, or altering the content of the report is not permitted without the written authorization of AGC. The test results presented in the report apply only to the tested sample. Any objections to report issued by AGC should be submitted to AGC within 15days after the issuance of the test report. Further enquiry of validity or verification of the test report should be addressed to AGC by agc01@agccert.com.

#### 7.4. TEST RESULT

Test Channel	Peak Power	EIRP	Limit
(MHz)	(dBm)	(dBm)	(dBm)
657	6.326	6.836	13
660	6.257	6.767	13
663	6.216	6.726	13

Any report having not been signed by authorized approver, or having been altered without authorization, or having not been stamped by the "Dedicated Testing/Inspection Stamp" is deemed to be invalid. Copying or excerpting portion of, or altering the content of the report is not permitted without the written authorization of AGC. The test results presented in the report apply only to the tested sample. Any objections to report issued by AGC should be submitted to AGC within 15days after the issuance of the test report. Further enquiry of validity or verification of the test report should be addressed to AGC by [agc01@agccert.com](mailto:agc01@agccert.com).

## 8. OCCUPIED BANDWIDTH

### 8.1. TEST LIMIT

The operating bandwidth shall not exceed 200 kHz.

### 8.2. MEASUREMENT PROCEDURE

1. For the occupied bandwidth measurements, the input signal shall be a 1 kHz tone. The level of the tone shall be set to the manufacturer's maximum rated input to the modulator.
2. Set the EUT Work on operation frequency.
3. Set Span = approximately 1.5 times the occupied bandwidth, centered on a channel  
The nominal IF filter bandwidth (3 dB RBW) shall be in the range of 1% to 5% of the OBW and video bandwidth (VBW) shall be approximately three times RBW; Sweep = auto; Detector function = peak
4. Set SPA Trace 1 Max hold, then View.

### 8.3. TEST SET-UP

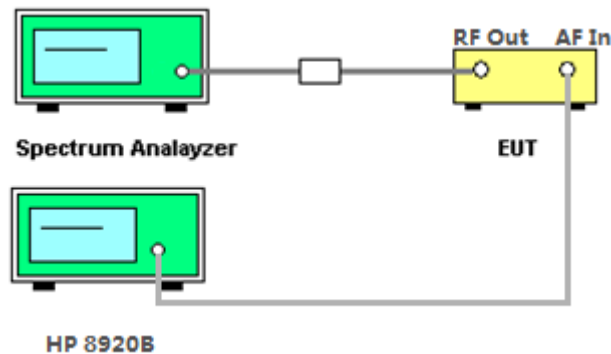

### 8.4. MEASUREMENT RESULTS

Test Channel (MHz)	-20dBc EBW (kHz)	99% OBW (kHz)	Limit (kHz)
657MHz	98.26	68.446	200
660MHz	87.04	66.504	200
663MHz	89.78	61.223	200

Any report having not been signed by authorized approver, or having been altered without authorization, or having not been stamped by the "Dedicated Testing/Inspection Stamp" is deemed to be invalid. Copying or excerpting portion of, or altering the content of the report is not permitted without the written authorization of AGC. The test results presented in the report apply only to the tested sample. Any objections to report issued by AGC should be submitted to AGC within 15days after the issuance of the test report. Further enquiry of validity or verification of the test report should be addressed to AGC by agc01@agccert.com.

### TEST PLOT OF BANDWIDTH

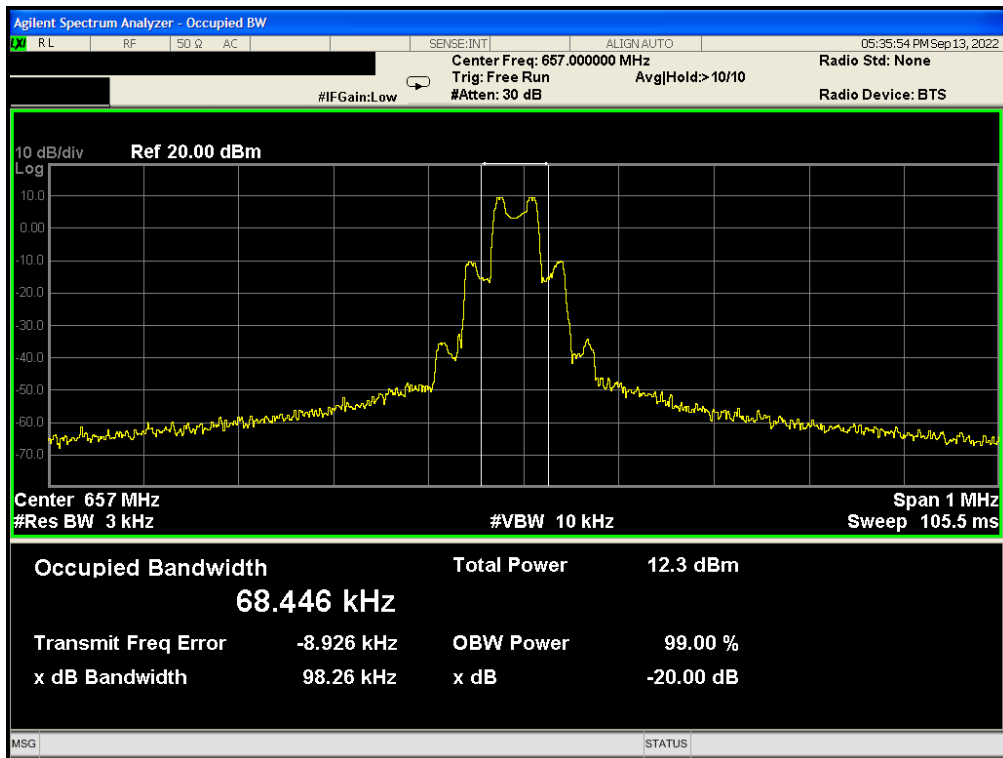

### TEST PLOT OF BANDWIDTH

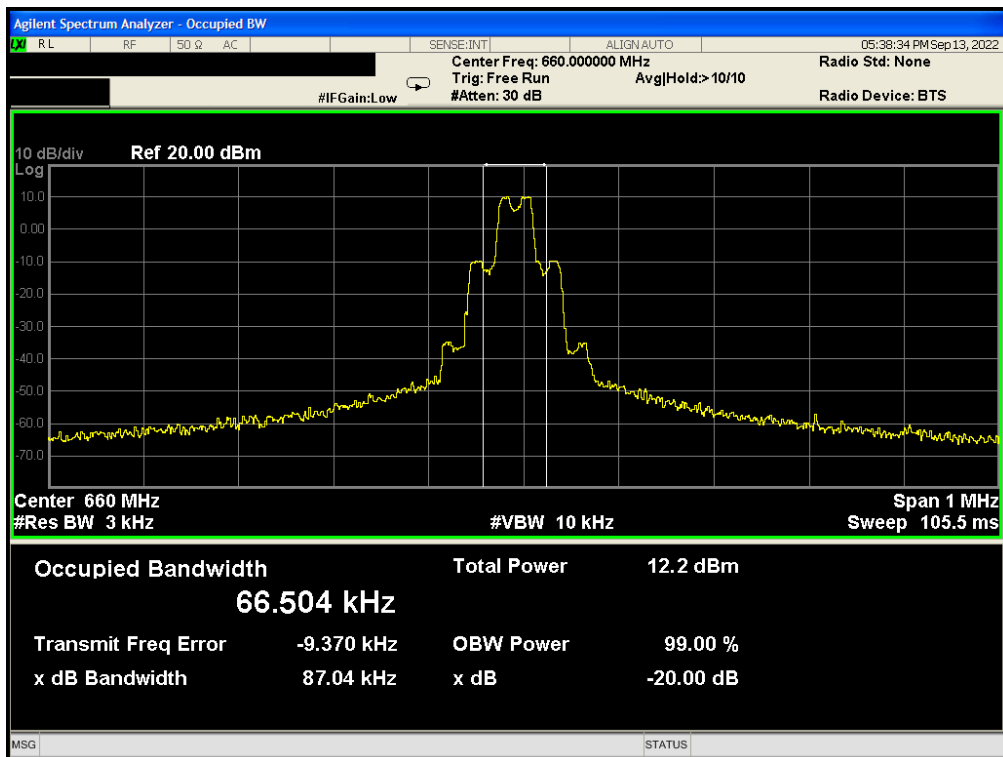

Any report having not been signed by authorized approver, or having been altered without authorization, or having not been stamped by the "Dedicated Testing/Inspection Stamp" is deemed to be invalid. Copying or excerpting portion of, or altering the content of the report is not permitted without the written authorization of AGC. The test results presented in the report apply only to the tested sample. Any objections to report issued by AGC should be submitted to AGC within 15days after the issuance of the test report. Further enquiry of validity or verification of the test report should be addressed to AGC by agc01@agccert.com.



### TEST PLOT OF BANDWIDTH

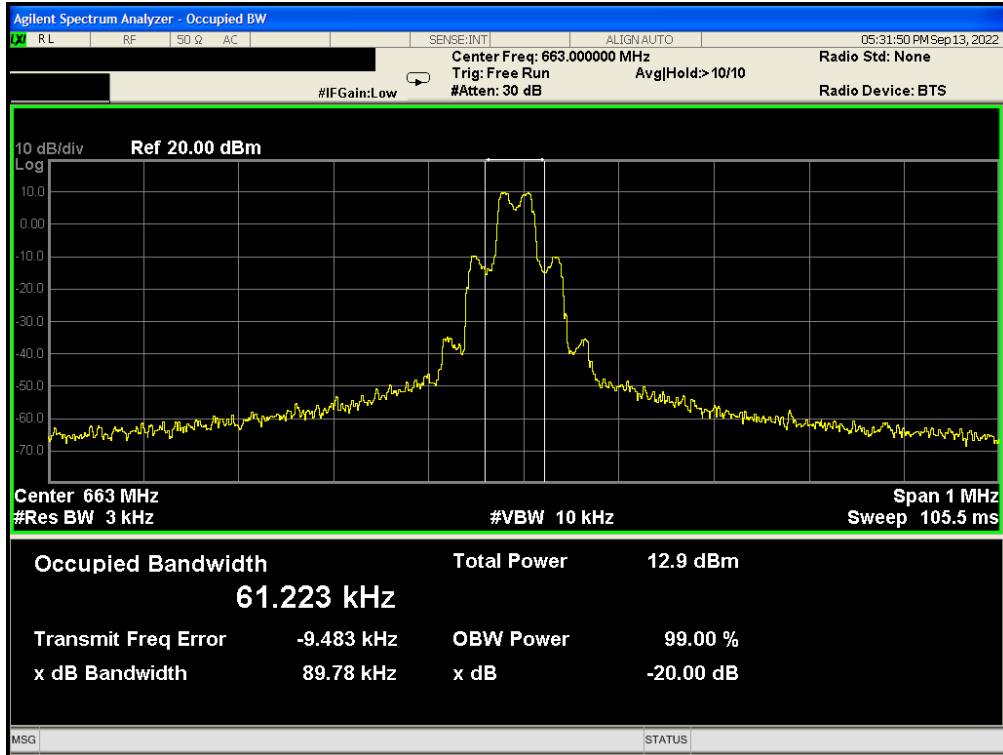

Any report having not been signed by authorized approver, or having been altered without authorization, or having not been stamped by the "Dedicated Testing/Inspection Stamp" is deemed to be invalid. Copying or excerpting portion of, or altering the content of the report is not permitted without the written authorization of AGC. The test results presented in the report apply only to the tested sample. Any objections to report issued by AGC should be submitted to AGC within 15days after the issuance of the test report. Further enquiry of validity or verification of the test report should be addressed to AGC by [agc01@agccert.com](mailto:agc01@agccert.com).

## 9. FREQUENCY STABILITY

### 9.1. TEST LIMIT

The frequency tolerance of the carrier signal shall be maintained within  $\pm 0.005\%$  of the operating frequency over a temperature variation of  $-30$  degrees to  $+50$  degrees C at normal supply voltage, and for a variation in the primary supply voltage from 85% to 115% of the rated supply voltage at a temperature of 20 degrees C.

### 9.2. MEASUREMENT PROCEDURE

1. Connect EUT RF output port to the Spectrum Analyzer through an RF attenuator
2. Set the EUT Work on the operation frequency.
3. Set SPA Centre Frequency = Operation Frequency, RBW= 1 KHz, VBW $\geq 3 \times$  RBW.
4. Set SPA Trace 1 Max hold, then View.
5. The test extreme voltage is to change the primary supply voltage from 85 to 115 percent of the nominal value
6. The  $f_c$  is declaring of channel frequency. Then the frequency error formula is  $(f_c - f) / f_c \times 10^6$  ppm and the limit is less than  $\pm 50$  ppm.
7. Extreme temperature rule is  $-30^\circ\text{C} \sim 50^\circ\text{C}$ .

### 9.3. TEST SET-UP

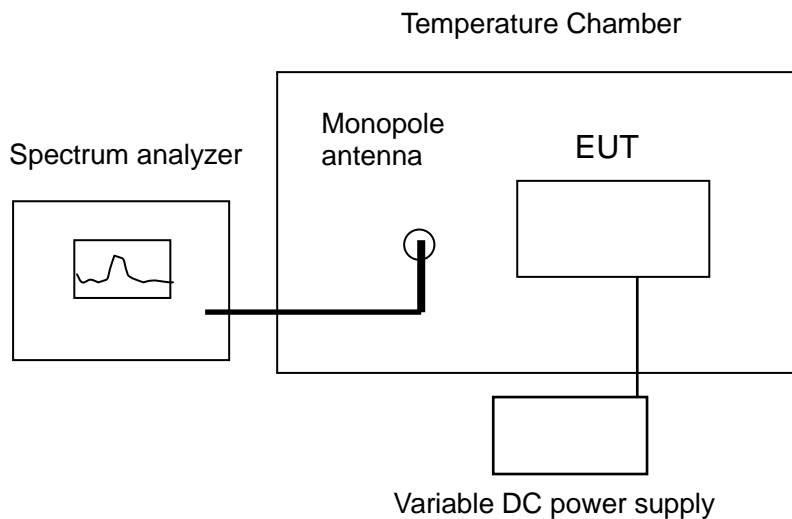

Any report having not been signed by authorized approver, or having been altered without authorization, or having not been stamped by the "Dedicated Testing/Inspection Stamp" is deemed to be invalid. Copying or excerpting portion of, or altering the content of the report is not permitted without the written authorization of AGC. The test results presented in the report apply only to the tested sample. Any objections to report issued by AGC should be submitted to AGC within 15 days after the issuance of the test report. Further enquiry of validity or verification of the test report should be addressed to AGC by [agc01@agccert.com](mailto:agc01@agccert.com).

#### 9.4. TEST RESULT

Operating frequency: 657MHz

Voltage vs. Frequency Stability (Test Temperature: 20°C)

Voltage(V)	Measurement Frequency (MHz)	Max. Deviation (ppm)	Limit(ppm)	Conclusion
3.15	657.0141	+22	±50	PASS
3.7	657.0143			
4.26	657.0124			

Temperature vs. Frequency Stability (Test Voltage: 3.7V)

Temperature	Measurement Frequency (MHz)	Max. Deviation (ppm)	Limit(ppm)	Conclusion
-30°C	657.0121	+21	±50	PASS
-20°C	657.0137			
-10°C	657.0132			
0°C	657.0139			
10°C	657.0126			
20°C	657.0114			
30°C	657.0125			
40°C	657.0112			
50°C	657.0126			

Operating frequency: 660MHz

Voltage vs. Frequency Stability (Test Temperature: 20°C)

Voltage(V)	Measurement Frequency (MHz)	Max. Deviation (ppm)	Limit(ppm)	Conclusion
3.15	660.0136	+22	±50	PASS
3.7	660.0147			
4.26	660.0123			

Temperature vs. Frequency Stability (Test Voltage: 3.7V)

Temperature	Measurement Frequency (MHz)	Max. Deviation (ppm)	Limit(ppm)	Conclusion
-30°C	660.0139	+22	±50	PASS
-20°C	660.0141			
-10°C	660.0132			
0°C	660.0134			
10°C	660.0147			
20°C	660.0146			
30°C	660.0138			
40°C	660.0137			
50°C	660.0134			

Any report having not been signed by authorized approver, or having been altered without authorization, or having not been stamped by the "Dedicated Testing/Inspection Stamp" is deemed to be invalid. Copying or excerpting portion of, or altering the content of the report is not permitted without the written authorization of AGC. The test results presented in the report apply only to the tested sample. Any objections to report issued by AGC should be submitted to AGC within 15days after the issuance of the test report. Further enquiry of validity or verification of the test report should be addressed to AGC by agc01@agccert.com.

Operating frequency: 663MHz

Voltage vs. Frequency Stability (Test Temperature: 20°C)

Voltage(V)	Measurement Frequency (MHz)	Max. Deviation (ppm)	Limit(ppm)	Conclusion
3.15	663.0232	+36	±50	PASS
3.7	663.0236			
4.26	663.0235			

Temperature vs. Frequency Stability (Test Voltage: 3.7V)

Temperature	Measurement Frequency (MHz)	Max. Deviation (ppm)	Limit(ppm)	Conclusion
-30°C	663.0237	+36	±50	PASS
-20°C	663.0235			
-10°C	663.0231			
0°C	663.0238			
10°C	663.0234			
20°C	663.0225			
30°C	663.0221			
40°C	663.0223			
50°C	663.0224			

Any report having not been signed by authorized approver, or having been altered without authorization, or having not been stamped by the "Dedicated Testing/Inspection Stamp" is deemed to be invalid. Copying or excerpting portion of, or altering the content of the report is not permitted without the written authorization of AGC. The test results presented in the report apply only to the tested sample. Any objections to report issued by AGC should be submitted to AGC within 15days after the issuance of the test report. Further enquiry of validity or verification of the test report should be addressed to AGC by agc01@agccert.com.

## 10. EMISSIONS WITHIN THE BAND AND OUTSIDE THE BAND

### 10.1. TEST LIMIT

Emissions within the band from one megahertz below to one megahertz above the carrier frequency shall comply with the emission mask in §8.3 of ETSI EN 300 422-1 V1.4.2 (2011-08).

Emissions outside of this band shall comply with the limits specified in section 8.4 of ETSI EN 300 422-1 V1.4.2 (2011-08).

### 10.2. MEASUREMENT PROCEDURE

#### Emission outside the band:

1. The EUT was placed on the top of the turntable 0.8 or 1.5 meter above ground. The phase center of the receiving antenna mounted on the top of a height-variable antenna tower was placed 3 meters far away from the turntable.
2. Power on the EUT and all the supporting units. The turntable was rotated by 360 degrees to determine the position of the highest radiation.
3. The height of the broadband receiving antenna was varied between one meter and four meters above ground to find the maximum emissions field strength of both horizontal and vertical polarization.
4. For each suspected emission, the antenna tower was scan (from 1 M to 4 M) and then the turntable was rotated (from 0 degree to 360 degrees) to find the maximum reading.
5. Set the test-receiver system to Peak or CISPR quasi-peak Detect Function with specified bandwidth under Maximum Hold Mode.
6.  $EIRP [dBm] = E[dB(\mu V)/m] - 95.2$

The following table is the setting of spectrum analyzer and receiver.

Spectrum Parameter	Setting
Start ~Stop Frequency	9KHz~150KHz/RB 200Hz for QP
Start ~Stop Frequency	150KHz~30MHz/RB 9KHz for QP
Start ~Stop Frequency	30MHz~1000MHz/RB 120KHz for QP
Start ~Stop Frequency	1000MHz~6000MHz/RB 1MHz for QP

#### Emission within the band:

- Method of Measurement for Analogue Systems in ETSI EN 300 422-1 Subclass 8.3.1  
 Method of Measurement for Digital Systems in ETSI EN 300 422-1 Subclass 8.3.2

### 10.3. TEST SETUP

#### Emission outside the band Radiated Emission Test-Setup Frequency Below 30MHz

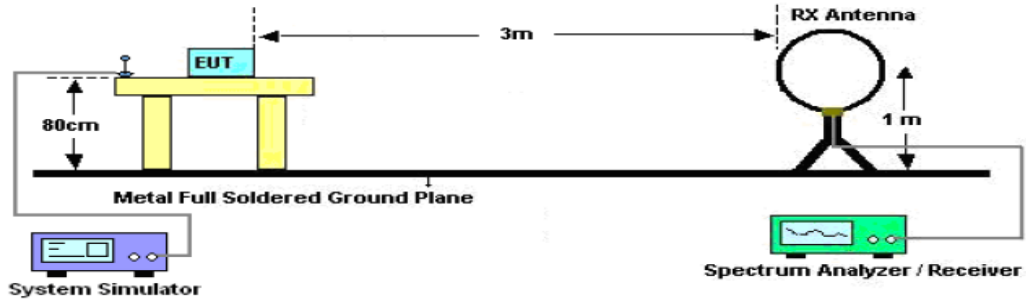

#### RADIATED EMISSION TEST SETUP 30MHz-1000MHz

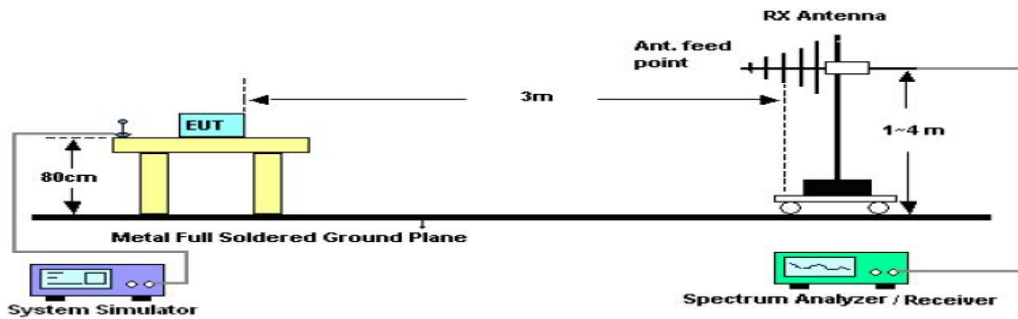

#### RADIATED EMISSION TEST SETUP ABOVE 1000MHz

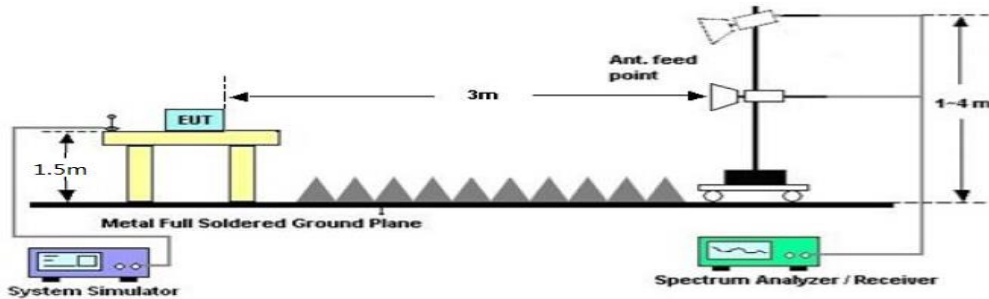

#### Emission within the band

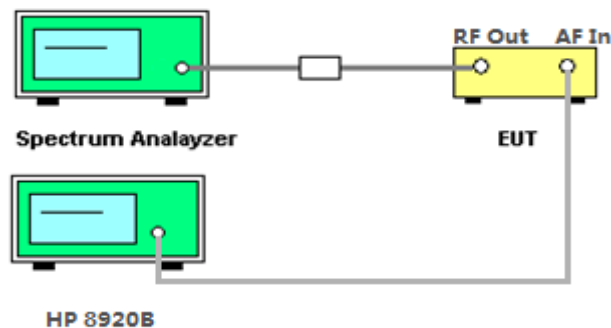

Any report having not been signed by authorized approver, or having been altered without authorization, or having not been stamped by the "Dedicated Testing/Inspection Stamp" is deemed to be invalid. Copying or excerpting portion of, or altering the content of the report is not permitted without the written authorization of AGC. The test results presented in the report apply only to the tested sample. Any objections to report issued by AGC should be submitted to AGC within 15days after the issuance of the test report. Further enquiry of validity or verification of the test report should be addressed to AGC by [agc01@agccert.com](mailto:agc01@agccert.com).

10.4. TEST RESULT

Emission within the band

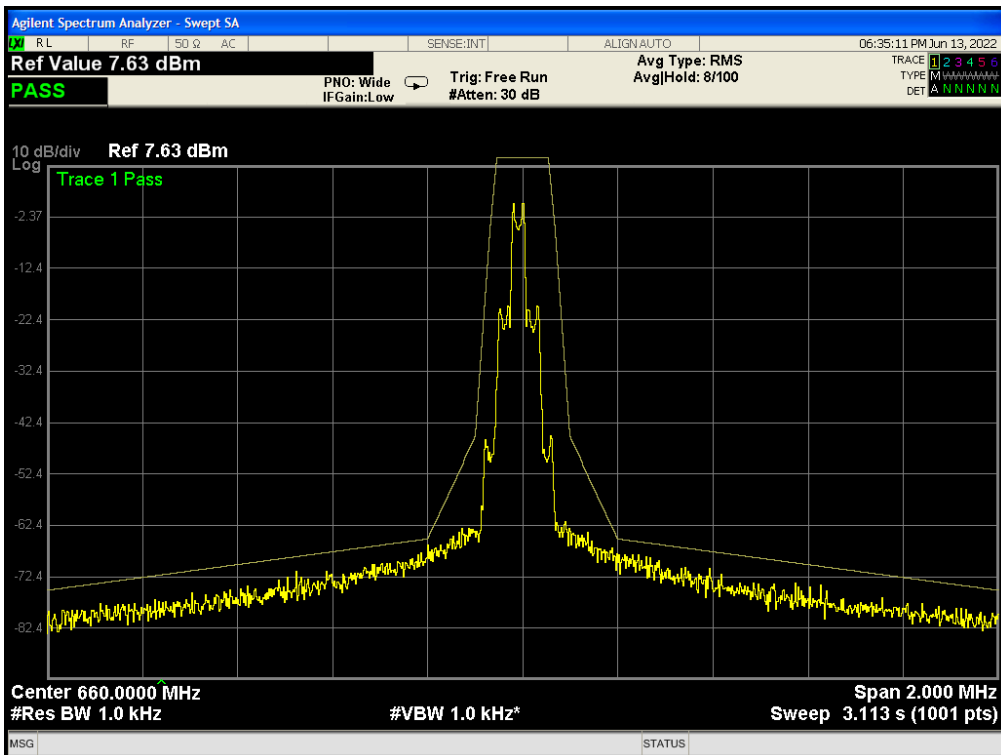
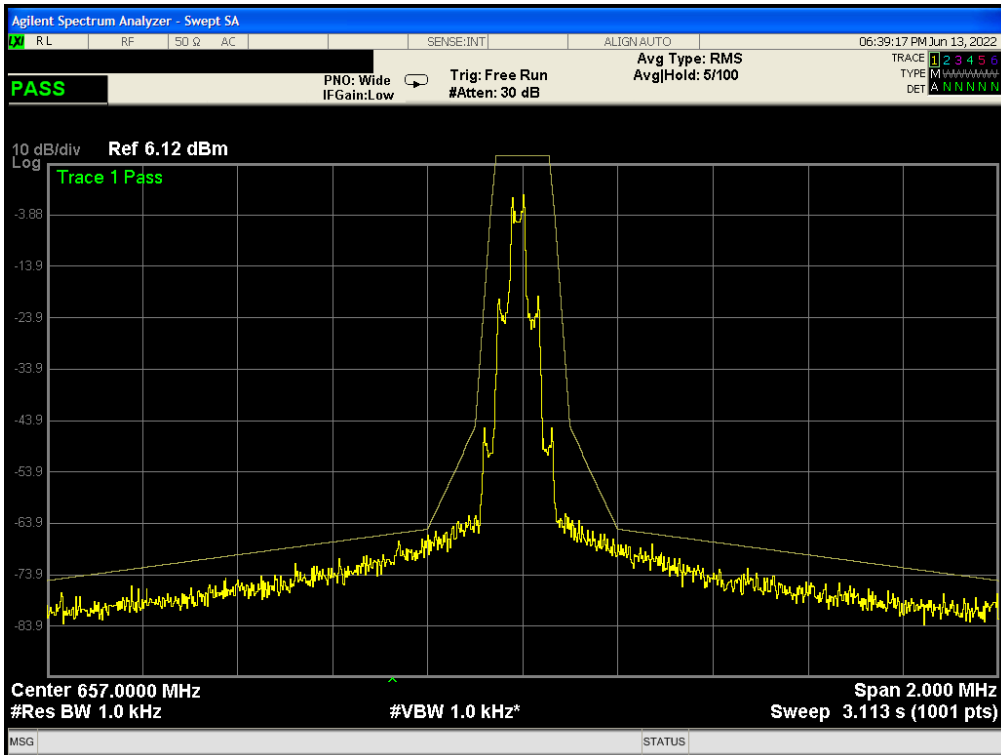

Any report having not been signed by authorized approver, or having been altered without authorization, or having not been stamped by the "Dedicated Testing/Inspection Stamp" is deemed to be invalid. Copying or excerpting portion of, or altering the content of the report is not permitted without the written authorization of AGC. The test results presented in the report apply only to the tested sample. Any objections to report issued by AGC should be submitted to AGC within 15days after the issuance of the test report. Further enquiry of validity or verification of the test report should be addressed to AGC by agc01@agccert.com.

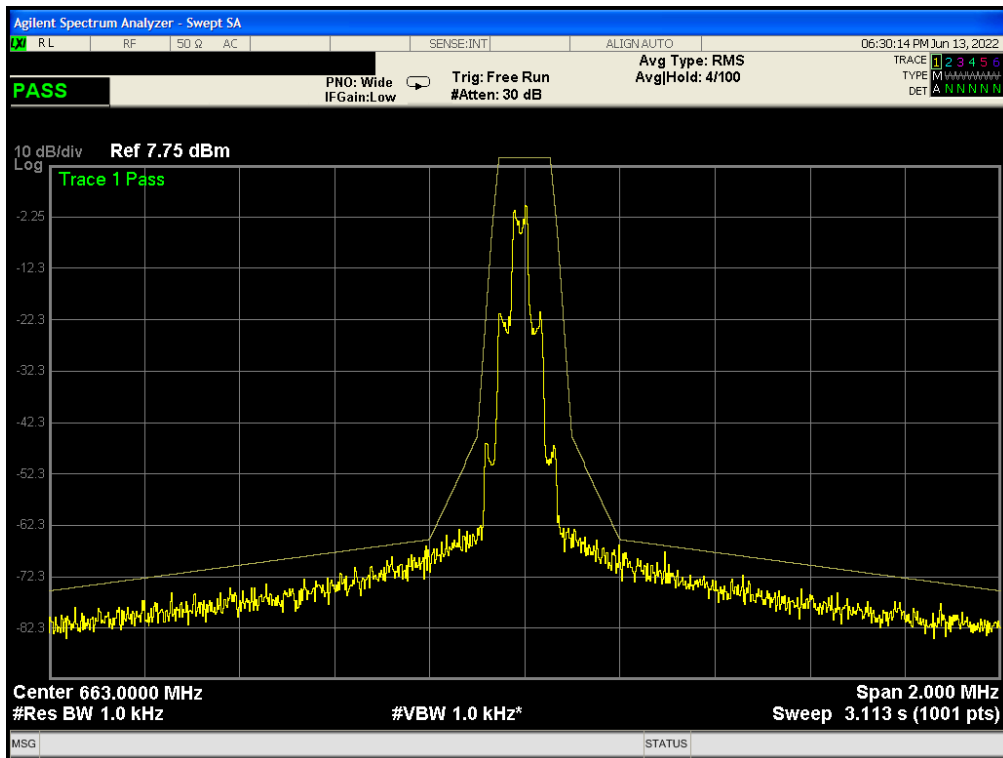

Note: 1.The manufacturer declared that the channel bandwidth is 200KHz.

2.The carrier power is the ref level, and the factor had been edited in the “Input Correction” of the Spectrum Analyzer.

Any report having not been signed by authorized approver, or having been altered without authorization, or having not been stamped by the “Dedicated Testing/Inspection Stamp” is deemed to be invalid. Copying or excerpting portion of, or altering the content of the report is not permitted without the written authorization of AGC. The test results presented in the report apply only to the tested sample. Any objections to report issued by AGC should be submitted to AGC within 15days after the issuance of the test report. Further enquiry of validity or verification of the test report should be addressed to AGC by agc01@agccert.com.

Attestation of Global Compliance(Shenzhen)Co., Ltd  
Attestation of Global Compliance(Shenzhen)Std & Tech Co., Ltd  
Tel: +86-755 2523 4088 E-mail: agc@agccert.com Web: http://www.agccert.com/



CH01

Emission outside the band 30-1000MHz

EUT	SLING AND SING KARAOKE	Model Name	CR-2714A
Temperature	20°C	Relative Humidity	57%
Pressure	986hPa	Test Voltage	Normal
Test Mode	Transmitting at 657MHz	Polarization	Horizontal

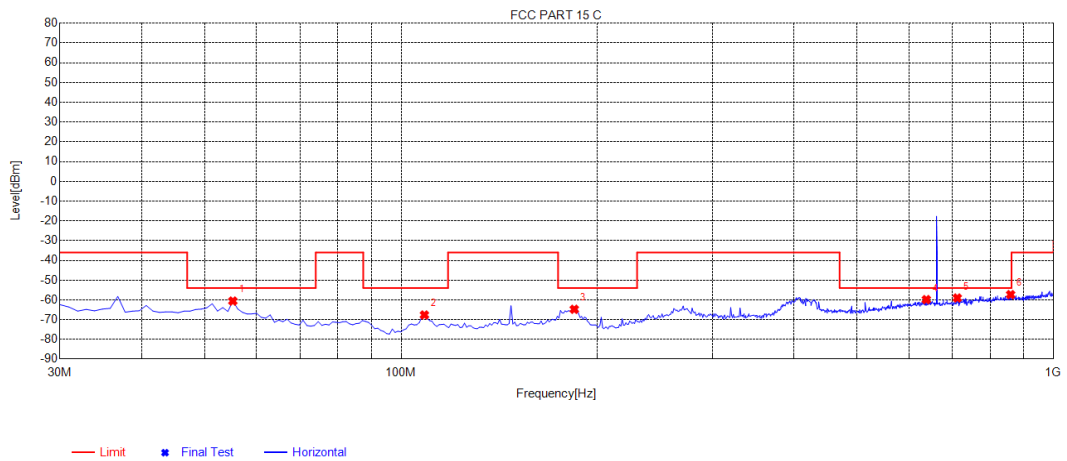

NO.	Freq. [MHz]	Reading [dBm]	Level [dBm]	Limit [dBm]	Margin [dB]	Factor [dB]	Angle [°]	Polarity
1	55.22	-92.75	-60.59	-54.00	6.59	32.16	127	Horizontal
2	108.57	-92.63	-67.62	-54.00	13.62	25.01	263	Horizontal
3	184.23	-93.74	-64.76	-54.00	10.76	28.98	214	Horizontal
4	638.19	-99.80	-59.85	-54.00	5.85	39.95	304	Horizontal
5	711.91	-99.54	-59.03	-54.00	5.03	40.51	255	Horizontal
6	859.35	-100.45	-57.31	-54.00	3.31	43.14	157	Horizontal

**RESULT: PASS**

Any report having not been signed by authorized approver, or having been altered without authorization, or having not been stamped by the "Dedicated Testing/Inspection Stamp" is deemed to be invalid. Copying or excerpting portion of, or altering the content of the report is not permitted without the written authorization of AGC. The test results presented in the report apply only to the tested sample. Any objections to report issued by AGC should be submitted to AGC within 15days after the issuance of the test report. Further enquiry of validity or verification of the test report should be addressed to AGC by agc01@agccert.com.

<b>EUT</b>	SLING AND SING KARAOKE	<b>Model Name</b>	CR-2714A
<b>Temperature</b>	20°C	<b>Relative Humidity</b>	57%
<b>Pressure</b>	986hPa	<b>Test Voltage</b>	Normal
<b>Test Mode</b>	Transmitting at 657MHz	<b>Polarization</b>	Vertical

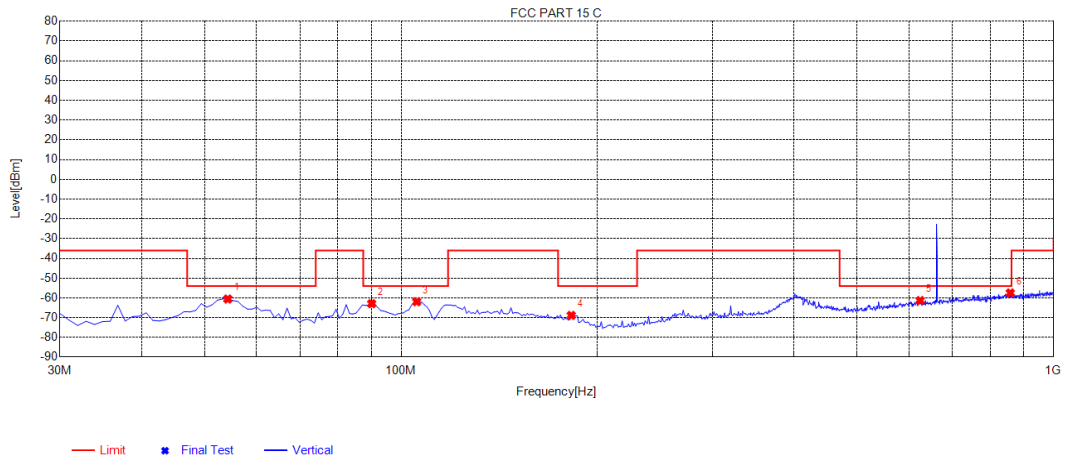

NO.	Freq. [MHz]	Reading [dBm]	Level [dBm]	Limit [dBm]	Margin [dB]	Factor [dB]	Angle [°]	Polarity
1	54.25	-91.04	-60.56	-54.00	6.56	30.48	316	Vertical
2	90.14	-91.12	-62.94	-54.00	8.94	28.18	9	Vertical
3	105.66	-92.28	-61.94	-54.00	7.94	30.34	1	Vertical
4	182.29	-98.99	-68.86	-54.00	14.86	30.13	181	Vertical
5	624.61	-100.50	-61.36	-54.00	7.36	39.14	360	Vertical
6	858.38	-100.41	-57.49	-54.00	3.49	42.92	222	Vertical

**RESULT: PASS**

Any report having not been signed by authorized approver, or having been altered without authorization, or having not been stamped by the “Dedicated Testing/Inspection Stamp” is deemed to be invalid. Copying or excerpting portion of, or altering the content of the report is not permitted without the written authorization of AGC. The test results presented in the report apply only to the tested sample. Any objections to report issued by AGC should be submitted to AGC within 15days after the issuance of the test report. Further enquiry of validity or verification of the test report should be addressed to AGC by agc01@agccert.com.

CH07

Emission outside the band 30-1000MHz

EUT	SLING AND SING KARAOKE	Model Name	CR-2714A
Temperature	20°C	Relative Humidity	57%
Pressure	986hPa	Test Voltage	Normal
Test Mode	Transmitting at 660MHz	Polarization	Horizontal

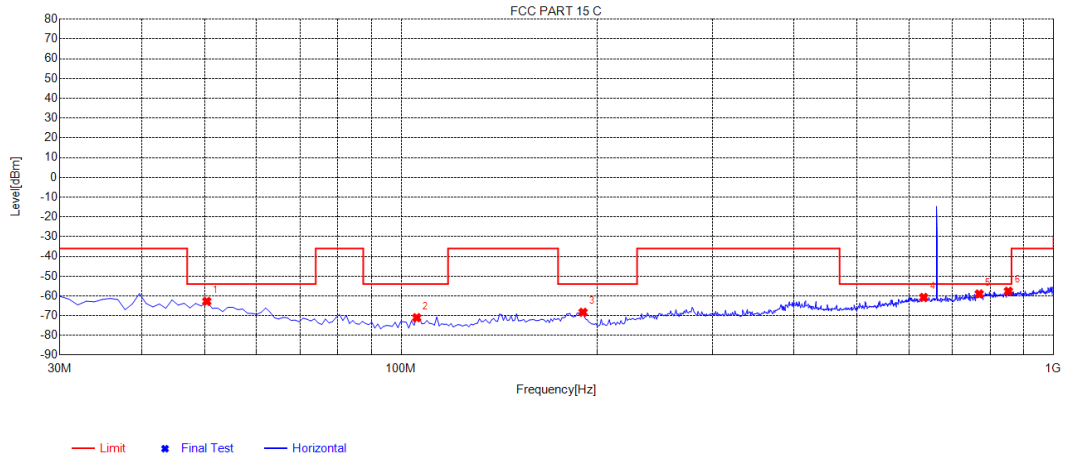

NO.	Freq. [MHz]	Reading [dBm]	Level [dBm]	Limit [dBm]	Margin [dB]	Factor [dB]	Angle [°]	Polarity
1	50.37	-96.34	-62.79	-54.00	8.79	33.55	200	Horizontal
2	105.66	-95.89	-71.02	-54.00	17.02	24.87	49	Horizontal
3	190.05	-96.53	-68.32	-54.00	14.32	28.21	260	Horizontal
4	632.37	-100.73	-60.79	-54.00	6.79	39.94	143	Horizontal
5	769.14	-101.41	-59.01	-54.00	5.01	42.40	81	Horizontal
6	852.56	-100.82	-57.65	-54.00	3.65	43.17	0	Horizontal

**RESULT: PASS**

Any report having not been signed by authorized approver, or having been altered without authorization, or having not been stamped by the "Dedicated Testing/Inspection Stamp" is deemed to be invalid. Copying or excerpting portion of, or altering the content of the report is not permitted without the written authorization of AGC. The test results presented in the report apply only to the tested sample. Any objections to report issued by AGC should be submitted to AGC within 15days after the issuance of the test report. Further enquiry of validity or verification of the test report should be addressed to AGC by agc01@agccert.com.

<b>EUT</b>	SLING AND SING KARAOKE	<b>Model Name</b>	CR-2714A
<b>Temperature</b>	20°C	<b>Relative Humidity</b>	57%
<b>Pressure</b>	986hPa	<b>Test Voltage</b>	Normal
<b>Test Mode</b>	Transmitting at 660MHz	<b>Polarization</b>	Vertical

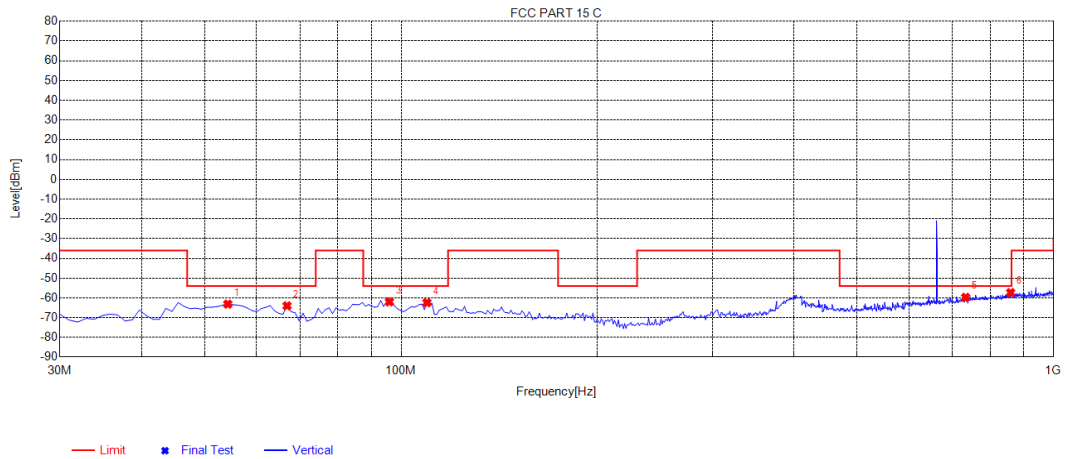

NO.	Freq. [MHz]	Reading [dBm]	Level [dBm]	Limit [dBm]	Margin [dB]	Factor [dB]	Angle [°]	Polarity
1	54.25	-93.64	-63.16	-54.00	9.16	30.48	294	Vertical
2	66.86	-93.00	-64.01	-54.00	10.01	28.99	324	Vertical
3	95.96	-90.84	-62.02	-54.00	8.02	28.82	272	Vertical
4	109.54	-93.49	-62.42	-54.00	8.42	31.07	253	Vertical
5	733.25	-100.83	-59.73	-54.00	5.73	41.10	9	Vertical
6	859.35	-100.23	-57.30	-54.00	3.30	42.93	101	Vertical

**RESULT: PASS**

Any report having not been signed by authorized approver, or having been altered without authorization, or having not been stamped by the "Dedicated Testing/Inspection Stamp" is deemed to be invalid. Copying or excerpting portion of, or altering the content of the report is not permitted without the written authorization of AGC. The test results presented in the report apply only to the tested sample. Any objections to report issued by AGC should be submitted to AGC within 15days after the issuance of the test report. Further enquiry of validity or verification of the test report should be addressed to AGC by agc01@agccert.com.

CH13

Emission outside the band 30-1000MHz

EUT	SLING AND SING KARAOKE	Model Name	CR-2714A
Temperature	20°C	Relative Humidity	57%
Pressure	986hPa	Test Voltage	Normal
Test Mode	Transmitting at 663MHz	Polarization	Horizontal

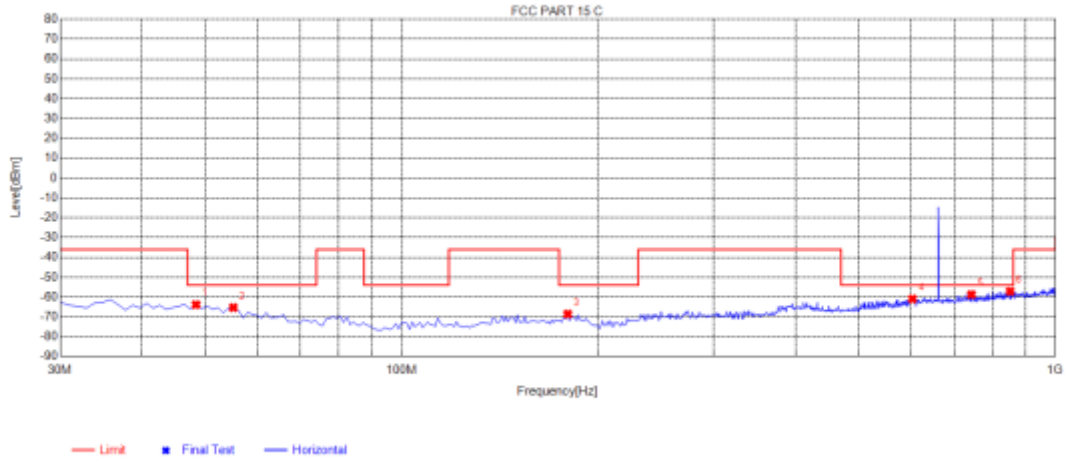

NO.	Freq. [MHz]	Reading [dBm]	Level [dBm]	Limit [dBm]	Margin [dB]	Factor [dB]	Angle [°]	Polarity
1	48.43	-97.71	-63.84	-54.00	9.84	33.87	108	Horizontal
2	55.22	-97.47	-65.31	-54.00	11.31	32.16	333	Horizontal
3	179.38	-98.08	-68.55	-54.00	14.55	29.53	162	Horizontal
4	604.24	-100.81	-60.95	-54.00	6.95	39.86	0	Horizontal
5	743.92	-100.30	-58.73	-54.00	4.73	41.57	359	Horizontal
6	852.56	-100.32	-57.15	-54.00	3.15	43.17	0	Horizontal

RESULT: PASS

Any report having not been signed by authorized approver, or having been altered without authorization, or having not been stamped by the "Dedicated Testing/Inspection Stamp" is deemed to be invalid. Copying or excerpting portion of, or altering the content of the report is not permitted without the written authorization of AGC. The test results presented in the report apply only to the tested sample. Any objections to report issued by AGC should be submitted to AGC within 15days after the issuance of the test report. Further enquiry of validity or verification of the test report should be addressed to AGC by agc01@agccert.com.

<b>EUT</b>	SLING AND SING KARAOKE	<b>Model Name</b>	CR-2714A
<b>Temperature</b>	20°C	<b>Relative Humidity</b>	57%
<b>Pressure</b>	986hPa	<b>Test Voltage</b>	Normal
<b>Test Mode</b>	Transmitting at 663MHz	<b>Polarization</b>	Vertical

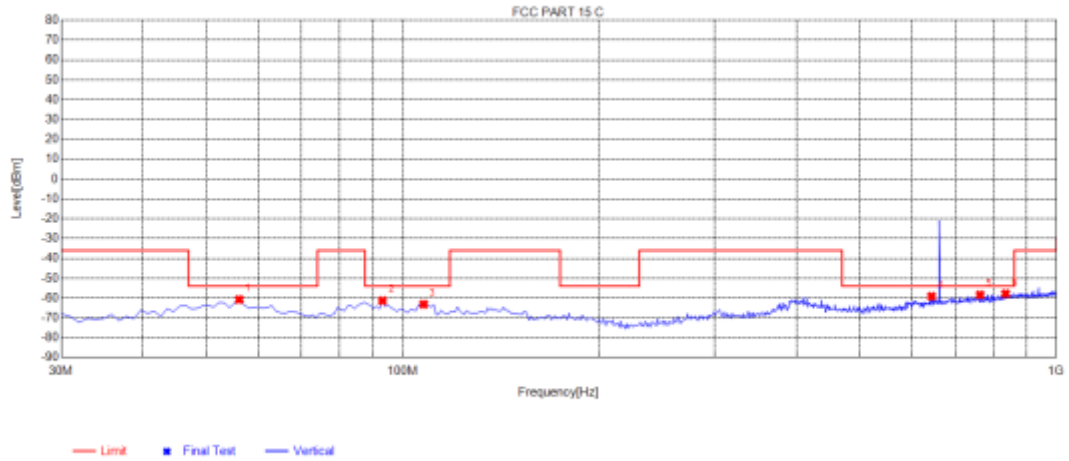

NO.	Freq. [MHz]	Reading [dBm]	Level [dBm]	Limit [dBm]	Margin [dB]	Factor [dB]	Angle [°]	Polarity
1	56.19	-91.54	-60.76	-54.00	6.76	30.78	160	Vertical
2	93.05	-89.81	-61.31	-54.00	7.31	28.50	253	Vertical
3	107.6	-93.85	-63.15	-54.00	9.15	30.70	343	Vertical
4	644.01	-98.64	-59.16	-54.00	5.16	39.48	9	Vertical
5	764.29	-100.07	-58.38	-54.00	4.38	41.69	333	Vertical
6	836.07	-100.53	-57.82	-54.00	3.82	42.71	360	Vertical

**RESULT: PASS**

**Note:** Factor=Antenna Factor + Cable loss, Margin=Level-Limit.

The “Factor” value can be calculated automatically by software of measurement system.

Any report having not been signed by authorized approver, or having been altered without authorization, or having not been stamped by the “Dedicated Testing/Inspection Stamp” is deemed to be invalid. Copying or excerpting portion of, or altering the content of the report is not permitted without the written authorization of AGC. The test results presented in the report apply only to the tested sample. Any objections to report issued by AGC should be submitted to AGC within 15days after the issuance of the test report. Further enquiry of validity or verification of the test report should be addressed to AGC by agc01@agccert.com.

**Emission outside the band above 1000MHz**

<b>EUT</b>	SLING AND SING KARAOKE	<b>Model Name</b>	CR-2714A
<b>Temperature</b>	20°C	<b>Relative Humidity</b>	57%
<b>Pressure</b>	986hPa	<b>Test Voltage</b>	Normal
<b>Test Mode</b>	Transmitting at 657MHz	<b>Polarization</b>	Horizontal/Vertical

Frequency (MHz)	Meter Reading (dBm)	Factor (dB)	Emission Level (dBm)	Limits (dBm)	Margin (dB)	Value Type
1314.000	-54.21	-2.16	-56.37	-30	-26.37	Horizontal
1314.000	-43.68	-2.16	-45.84	-30	-15.84	Vertical
1791.000	-53.64	-3.02	-56.66	-30	-26.66	Horizontal
1791.000	-41.27	-3.02	-44.29	-30	-14.29	Vertical

Remark:  
Factor = Antenna Factor + Cable Loss – Pre-amplifier.

<b>EUT</b>	SLING AND SING KARAOKE	<b>Model Name</b>	CR-2714A
<b>Temperature</b>	20°C	<b>Relative Humidity</b>	57%
<b>Pressure</b>	986hPa	<b>Test Voltage</b>	Normal
<b>Test Mode</b>	Transmitting at 660MHz	<b>Polarization</b>	Horizontal/Vertical

Frequency (MHz)	Meter Reading (dBm)	Factor (dB)	Emission Level (dBm)	Limits (dBm)	Margin (dB)	Value Type
1320.000	-53.67	-2.07	-55.74	-30	-25.74	Horizontal
1320.000	-44.23	-2.07	-46.3	-30	-16.3	Vertical
1980.000	-53.08	-2.95	-56.03	-30	-26.03	Horizontal
1980.000	-42.83	-2.95	-45.78	-30	-15.78	Vertical

Remark:  
Factor = Antenna Factor + Cable Loss – Pre-amplifier.

Any report having not been signed by authorized approver, or having been altered without authorization, or having not been stamped by the “Dedicated Testing/Inspection Stamp” is deemed to be invalid. Copying or excerpting portion of, or altering the content of the report is not permitted without the written authorization of AGC. The test results presented in the report apply only to the tested sample. Any objections to report issued by AGC should be submitted to AGC within 15days after the issuance of the test report. Further enquiry of validity or verification of the test report should be addressed to AGC by agc01@agccert.com.

27

<b>EUT</b>	SLING AND SING KARAOKE	<b>Model Name</b>	CR-2714A
<b>Temperature</b>	20°C	<b>Relative Humidity</b>	57%
<b>Pressure</b>	986hPa	<b>Test Voltage</b>	Normal
<b>Test Mode</b>	Transmitting at 663MHz	<b>Polarization</b>	Horizontal/Vertical

Frequency (MHz)	Meter Reading (dBm)	Factor (dB)	Emission Level (dBm)	Limits (dBm)	Margin (dB)	Value Type
1326.000	-55.89	-2.25	-58.14	-30	-28.14	Horizontal
1326.000	-45.21	-2.25	-47.46	-30	-17.46	Vertical
1989.000	-54.99	-3.24	-58.23	-30	-28.23	Horizontal
1989.000	-42.67	-3.24	-45.91	-30	-15.91	Vertical
Remark:						
Factor = Antenna Factor + Cable Loss – Pre-amplifier.						

**RESULT: PASS**

**Note:** Other emissions from 1G to 7 GHz are considered as ambient noise. No recording in the test report.  
The “Factor” value can be calculated automatically by software of measurement system.

Any report having not been signed by authorized approver, or having been altered without authorization, or having not been stamped by the “Dedicated Testing/Inspection Stamp” is deemed to be invalid. Copying or excerpting portion of, or altering the content of the report is not permitted without the written authorization of AGC. The test results presented in the report apply only to the tested sample. Any objections to report issued by AGC should be submitted to AGC within 15days after the issuance of the test report. Further enquiry of validity or verification of the test report should be addressed to AGC by agc01@agccert.com.



## 11. LINE CONDUCTED EMISSION TEST

### 11.1. LIMITS OF LINE CONDUCTED EMISSION TEST

Frequency	Maximum RF Line Voltage	
	Q.P. (dB $\mu$ V)	Average (dB $\mu$ V)
150kHz~500kHz	66-56	56-46
500kHz~5MHz	56	46
5MHz~30MHz	60	50

Note: 1. The lower limit shall apply at the transition frequency.

2. The limit decreases linearly with the logarithm of the frequency in the range 0.15 MHz to 0.50 MHz.

### 11.2. BLOCK DIAGRAM OF LINE CONDUCTED EMISSION TEST

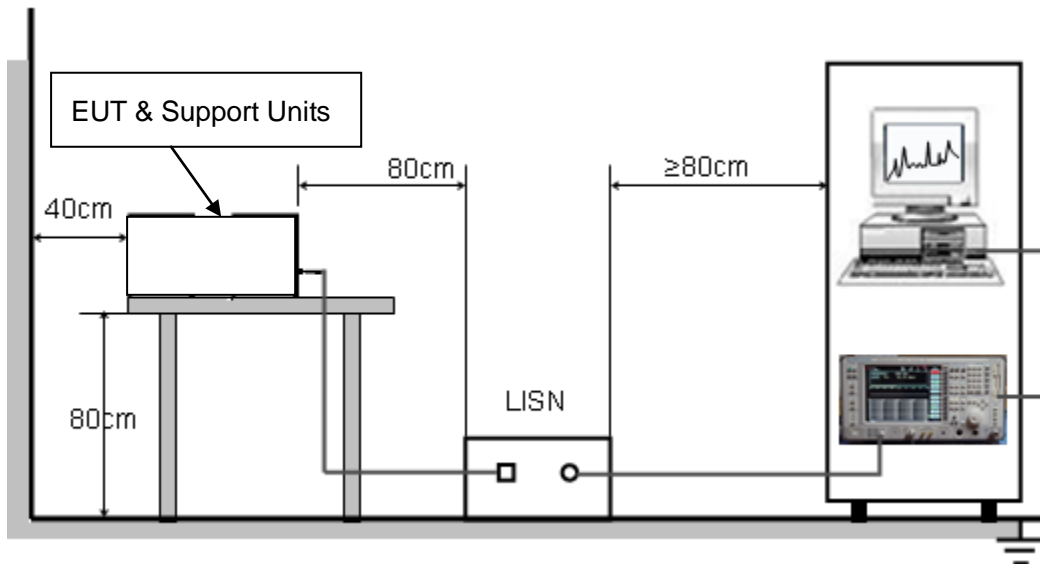

Any report having not been signed by authorized approver, or having been altered without authorization, or having not been stamped by the "Dedicated Testing/Inspection Stamp" is deemed to be invalid. Copying or excerpting portion of, or altering the content of the report is not permitted without the written authorization of AGC. The test results presented in the report apply only to the tested sample. Any objections to report issued by AGC should be submitted to AGC within 15days after the issuance of the test report. Further enquiry of validity or verification of the test report should be addressed to AGC by [agc01@agccert.com](mailto:agc01@agccert.com).

### 11.3. PRELIMINARY PROCEDURE OF LINE CONDUCTED EMISSION TEST

1. The equipment was set up as per the test configuration to simulate typical actual usage per the user's manual. When the EUT is a tabletop system, a wooden table with a height of 0.8 meters is used and is placed on the ground plane as per ANSI C63.10 (see Test Facility for the dimensions of the ground plane used). When the EUT is a floor-standing equipment, it is placed on the ground plane which has a 3-12 mm non-conductive covering to insulate the EUT from the ground plane.
2. Support equipment, if needed, was placed as per ANSI C63.10.
3. All I/O cables were positioned to simulate typical actual usage as per ANSI C63.10.
4. All support equipment received AC120V/60Hz power from a LISN, if any.
5. The EUT received DC 5V power from adapter which received AC120V/60Hz power from a LISN.
6. The test program was started. Emissions were measured on each current carrying line of the EUT using a spectrum Analyzer / Receiver connected to the LISN powering the EUT. The LISN has two monitoring points: Line 1 (Hot Side) and Line 2 (Neutral Side). Two scans were taken: one with Line 1 connected to Analyzer / Receiver and Line 2 connected to a 50 ohm load; the second scan had Line 1 connected to a 50 ohm load and Line 2 connected to the Analyzer / Receiver.
7. Analyzer / Receiver scanned from 150 kHz to 30MHz for emissions in each of the test modes.
8. During the above scans, the emissions were maximized by cable manipulation.
9. The test mode(s) were scanned during the preliminary test.

Then, the EUT configuration and cable configuration of the above highest emission level were recorded for reference of final testing.

### 11.4. FINAL PROCEDURE OF LINE CONDUCTED EMISSION TEST

1. EUT and support equipment was set up on the test bench as per step 2 of the preliminary test.
2. A scan was taken on both power lines, Line 1 and Line 2, recording at least the six highest emissions. Emission frequency and amplitude were recorded into a computer in which correction factors were used to calculate the emission level and compare reading to the applicable limit. If EUT emission level was less -2dB to the A.V. limit in Peak mode, then the emission signal was re-checked using Q.P and Average detector.
3. The test data of the worst case condition(s) was reported on the Summary Data page.

### 11.5. TEST RESULT OF LINE CONDUCTED EMISSION TEST

#### LINE CONDUCTED EMISSION TEST-L1

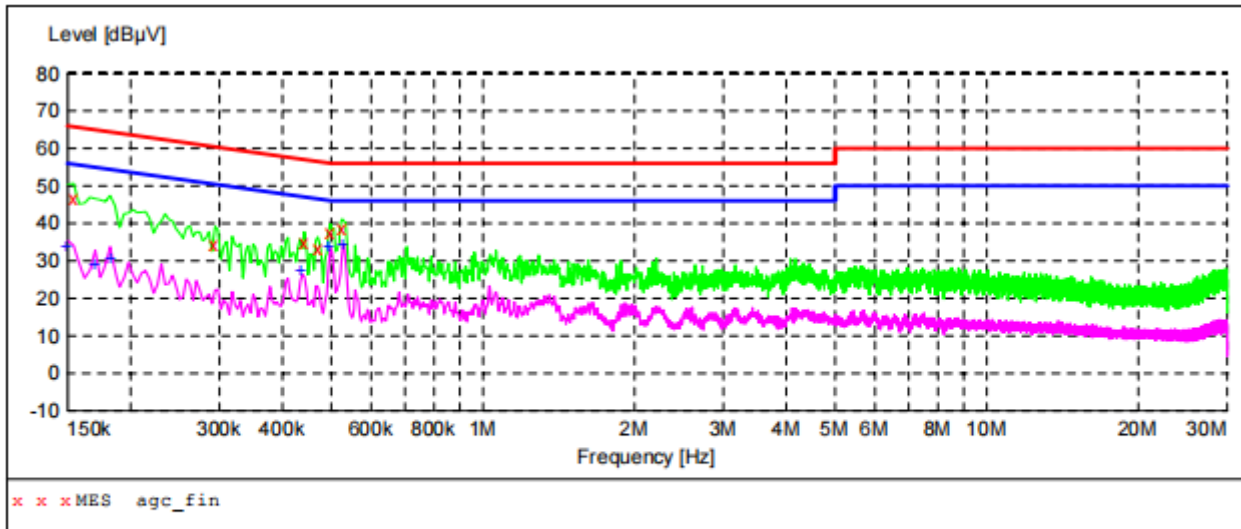

#### MEASUREMENT RESULT: "agc\_fin"

2022/9/15 17:10

Frequency MHz	Level dBµV	Transd dB	Limit dBµV	Margin dB	Detector	Line	PE
0.154000	46.80	6.9	66	19.0	QP	L1	GND
0.294000	34.20	6.1	60	26.2	QP	L1	GND
0.442000	34.80	5.6	57	22.2	QP	L1	GND
0.470000	33.40	5.5	57	23.1	QP	L1	GND
0.498000	37.70	5.4	56	18.3	QP	L1	GND
0.526000	38.80	5.4	56	17.2	QP	L1	GND

#### MEASUREMENT RESULT: "agc\_fin2"

2022/9/15 17:10

Frequency MHz	Level dBµV	Transd dB	Limit dBµV	Margin dB	Detector	Line	PE
0.150000	34.10	6.9	56	21.9	AV	L1	GND
0.170000	29.00	6.8	55	26.0	AV	L1	GND
0.182000	30.50	6.7	54	23.9	AV	L1	GND
0.438000	27.60	5.6	47	19.5	AV	L1	GND
0.498000	33.70	5.4	46	12.3	AV	L1	GND
0.530000	34.60	5.4	46	11.4	AV	L1	GND

**RESULT: PASS**

Any report having not been signed by authorized approver, or having been altered without authorization, or having not been stamped by the "Dedicated Testing/Inspection Stamp" is deemed to be invalid. Copying or excerpting portion of, or altering the content of the report is not permitted without the written authorization of AGC. The test results presented in the report apply only to the tested sample. Any objections to report issued by AGC should be submitted to AGC within 15days after the issuance of the test report. Further enquiry of validity or verification of the test report should be addressed to AGC by agc01@agccert.com.

LINE CONDUCTED EMISSION TEST-N

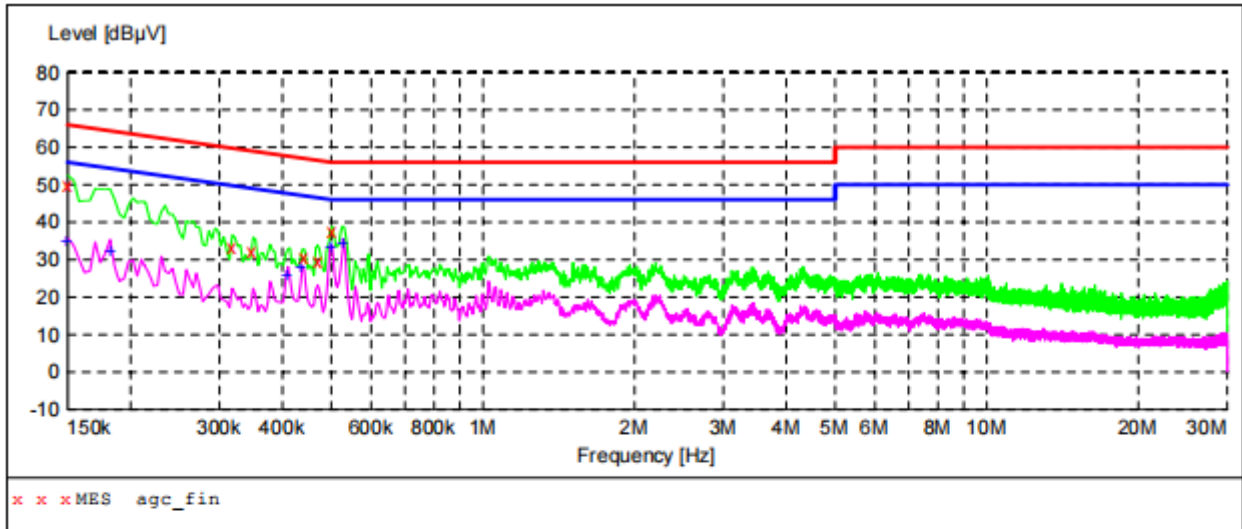

**MEASUREMENT RESULT: "agc\_fin"**

2022/9/15 17:07

Frequency MHz	Level dBµV	Transd dB	Limit dBµV	Margin dB	Detector	Line	PE
0.150000	49.60	6.9	66	16.4	QP	N	GND
0.318000	33.40	6.0	60	26.4	QP	N	GND
0.350000	32.20	5.8	59	26.8	QP	N	GND
0.442000	30.50	5.6	57	26.5	QP	N	GND
0.470000	29.60	5.5	57	26.9	QP	N	GND
0.502000	37.80	5.4	56	18.2	QP	N	GND

**MEASUREMENT RESULT: "agc\_fin2"**

2022/9/15 17:07

Frequency MHz	Level dBµV	Transd dB	Limit dBµV	Margin dB	Detector	Line	PE
0.150000	35.10	6.9	56	20.9	AV	N	GND
0.182000	32.30	6.7	54	22.1	AV	N	GND
0.410000	25.80	5.7	48	21.8	AV	N	GND
0.438000	28.00	5.6	47	19.1	AV	N	GND
0.502000	33.10	5.4	46	12.9	AV	N	GND
0.530000	34.60	5.4	46	11.4	AV	N	GND

**RESULT: PASS**

Any report having not been signed by authorized approver, or having been altered without authorization, or having not been stamped by the "Dedicated Testing/Inspection Stamp" is deemed to be invalid. Copying or excerpting portion of, or altering the content of the report is not permitted without the written authorization of AGC. The test results presented in the report apply only to the tested sample. Any objections to report issued by AGC should be submitted to AGC within 15days after the issuance of the test report. Further enquiry of validity or verification of the test report should be addressed to AGC by agc01@agccert.com.

## **APPENDIX A: PHOTOGRAPHS OF TEST SETUP**

Refer to the Report No.: AGC00203220903AP01

## **APPENDIX B: PHOTOGRAPHS OF EUT**

Refer to the Report No.: AGC00203220903AP02

**----END OF REPORT----**

Any report having not been signed by authorized approver, or having been altered without authorization, or having not been stamped by the "Dedicated Testing/Inspection Stamp" is deemed to be invalid. Copying or excerpting portion of, or altering the content of the report is not permitted without the written authorization of AGC. The test results presented in the report apply only to the tested sample. Any objections to report issued by AGC should be submitted to AGC within 15days after the issuance of the test report. Further enquiry of validity or verification of the test report should be addressed to AGC by [agc01@agccert.com](mailto:agc01@agccert.com).

Attestation of Global Compliance(Shenzhen)Co., Ltd

Attestation of Global Compliance(Shenzhen)Std & Tech Co., Ltd

Tel: +86-755 2523 4088 E-mail: [agc@agccert.com](mailto:agc@agccert.com) Web: <http://www.agccert.com/>



## Conditions of Issuance of Test Reports

1. All samples and goods are accepted by the Attestation of Global Compliance (Shenzhen) Co., Ltd. (the “Company”) solely for testing and reporting in accordance with the following terms and conditions. The company provides its services on the basis that such terms and conditions constitute express agreement between the company and any person, firm or company requesting its services (the “Clients”).
2. Any report issued by Company as a result of this application for testing services (the “Report”) shall be issued in confidence to the Clients and the Report will be strictly treated as such by the Company. It may not be reproduced either in its entirety or in part and it may not be used for advertising or other unauthorized purposes without the written consent of the Company. The Clients to whom the Report is issued may, however, show or send it, or a certified copy thereof prepared by the Company to its customer, supplier or other persons directly concerned. The Company will not, without the consent of the Clients, enter into any discussion or correspondence with any third party concerning the contents of the Report, unless required by the relevant governmental authorities, laws or court orders.
3. The Company shall not be called or be liable to be called to give evidence or testimony on the Report in a court of law without its prior written consent, unless required by the relevant governmental authorities, laws or court orders.
4. In the event of the improper use of the report as determined by the Company, the Company reserves the right to withdraw it, and to adopt any other additional remedies which may be appropriate.
5. Samples submitted for testing are accepted on the understanding that the Report issued cannot form the basis of, or be the instrument for, any legal action against the Company.
6. The Company will not be liable for or accept responsibility for any loss or damage however arising from the use of information contained in any of its Reports or in any communication whatsoever about its said tests or investigations.
7. Clients wishing to use the Report in court proceedings or arbitration shall inform the Company to that effect prior to submitting the sample for testing.
8. The Company is not responsible for recalling the electronic version of the original report when any revision is made to them. The Client assumes the responsibility to providing the revised version to any interested party who uses them.
9. Subject to the variable length of retention time for test data and report stored hereinto as otherwise specifically required by individual accreditation authorities, the Company will only keep the supporting test data and information of the test report for a period of six years. The data and information will be disposed of after the aforementioned retention period has elapsed. Under no circumstances shall we provide any data and information which has been disposed of after retention period. Under no circumstances shall we be liable for damage of any kind, including (but not limited to) compensatory damages, lost profits, lost data, or any form of special, incidental, indirect, consequential or punitive damages of any kind, whether based on breach of contract of warranty, tort (including negligence), product liability or otherwise, even if we are informed in advance of the possibility of such damages.

Any report having not been signed by authorized approver, or having been altered without authorization, or having not been stamped by the “Dedicated Testing/Inspection Stamp” is deemed to be invalid. Copying or excerpting portion of, or altering the content of the report is not permitted without the written authorization of AGC. The test results presented in the report apply only to the tested sample. Any objections to report issued by AGC should be submitted to AGC within 15days after the issuance of the test report. Further enquiry of validity or verification of the test report should be addressed to AGC by [agc01@agccert.com](mailto:agc01@agccert.com).