

7.6. Time of Occupancy Measurement

7.6.1. Test Limit

The maximum permissible time of occupancy is 400ms within a period of 400ms multiplied by the number of hopping channels employed.

7.6.2. Test Procedure Used

ANSI C63.10-2013 - Section 7.8.4

7.6.3. Test Settling

1. Span = zero span, centered on a hopping channel.
2. RBW = 1MHz
3. VBW \geq RBW
4. Sweep time = as necessary to capture the entire dwell time per hopping channel
5. Detector = Peak
6. Trace mode = max hold

If possible, use the marker-delta function to determine the dwell time. If this value varies with different modes of operation (data rate, modulation format, etc.), repeat this test for each variation.

An oscilloscope may be used instead of a spectrum analyzer. The EUT shall show compliance with the appropriate regulatory limit for the number of hopping channels. A plot of the data shall be included in the test report.

7.6.4. Test Setup

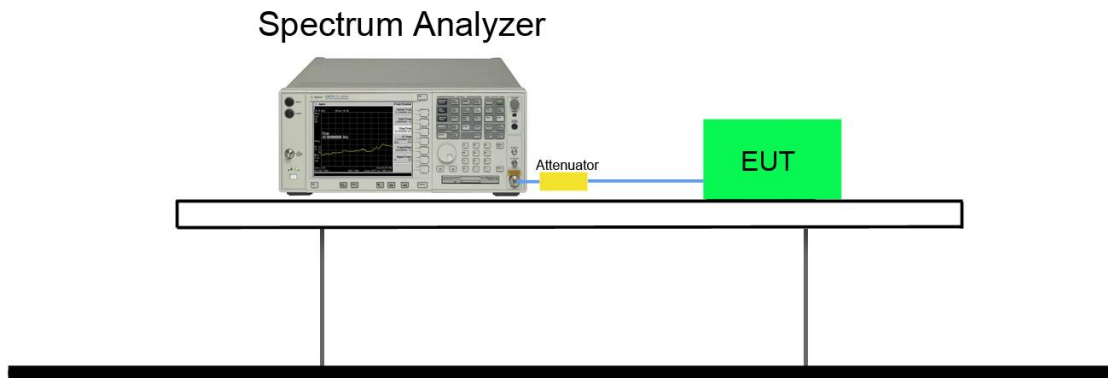

7.6.5. Test Result

Test Mode	Channel No.	Frequency (MHz)	Time of Occupancy (ms)	Limit (ms)	Result
3DH1	39	2441	168.48	< 400	Pass
3DH3	39	2441	306.24	< 400	Pass
3DH5	39	2441	352.80	< 400	Pass

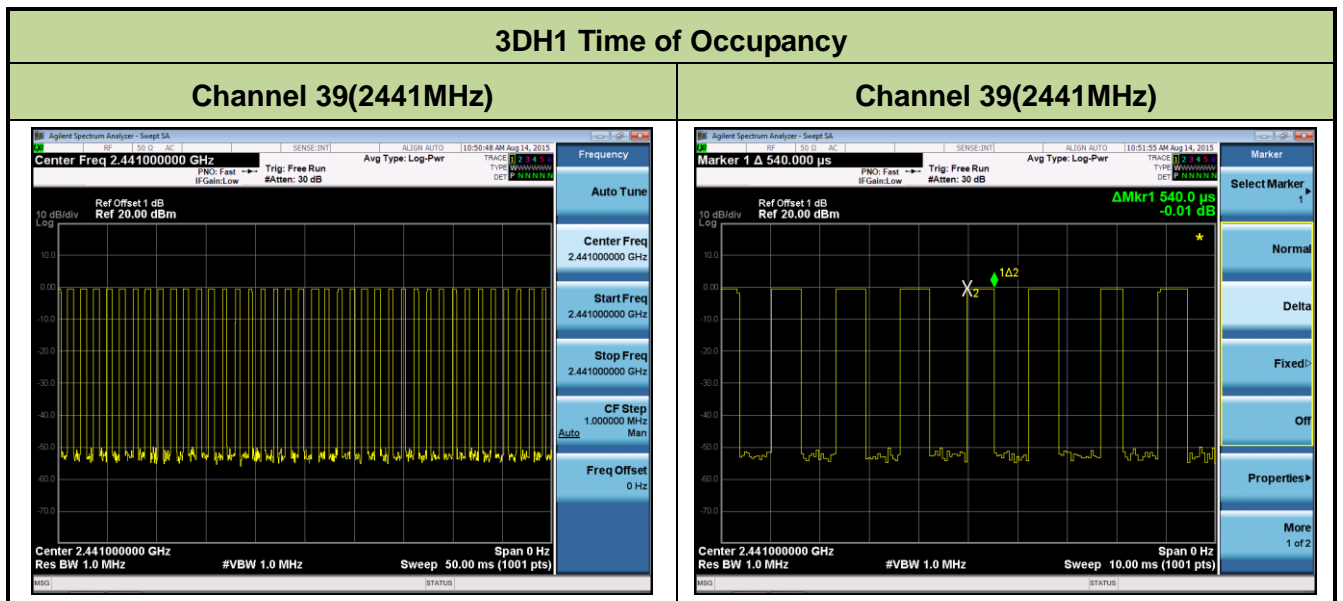

Note: Test Time Period: $0.4 * 79 = 31.6$ sec, Hopping Times Within 1sec: $39 / 50 \text{msec} = 780$ hops/sec.

The Maximum Occupancy Time within 31.6sec: $[(0.540 \text{ms} * 780) / 79] * 31.6 = 168.48$

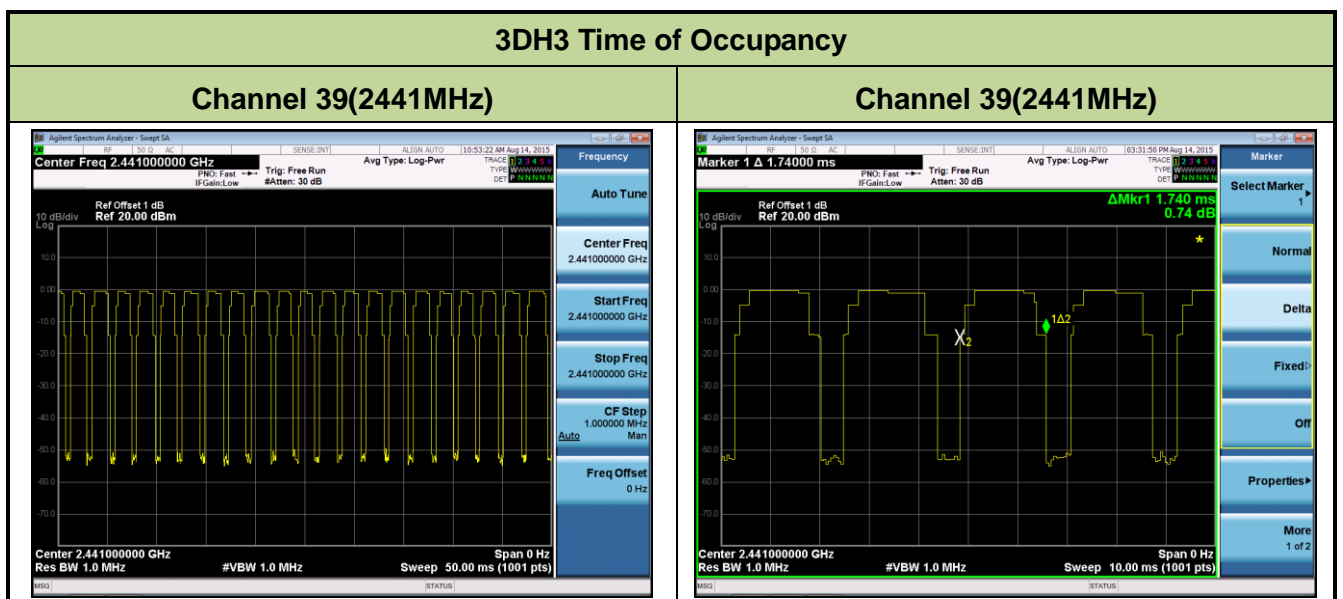

Note: Test Time Period: $0.4 * 79 = 31.6$ sec, Hopping Times Within 1sec: $22 / 50 \text{msec} = 440$ hops/sec.

The Maximum Occupancy Time within 31.6sec: $[(1.740 \text{ms} * 440) / 79] * 31.6 = 306.24$

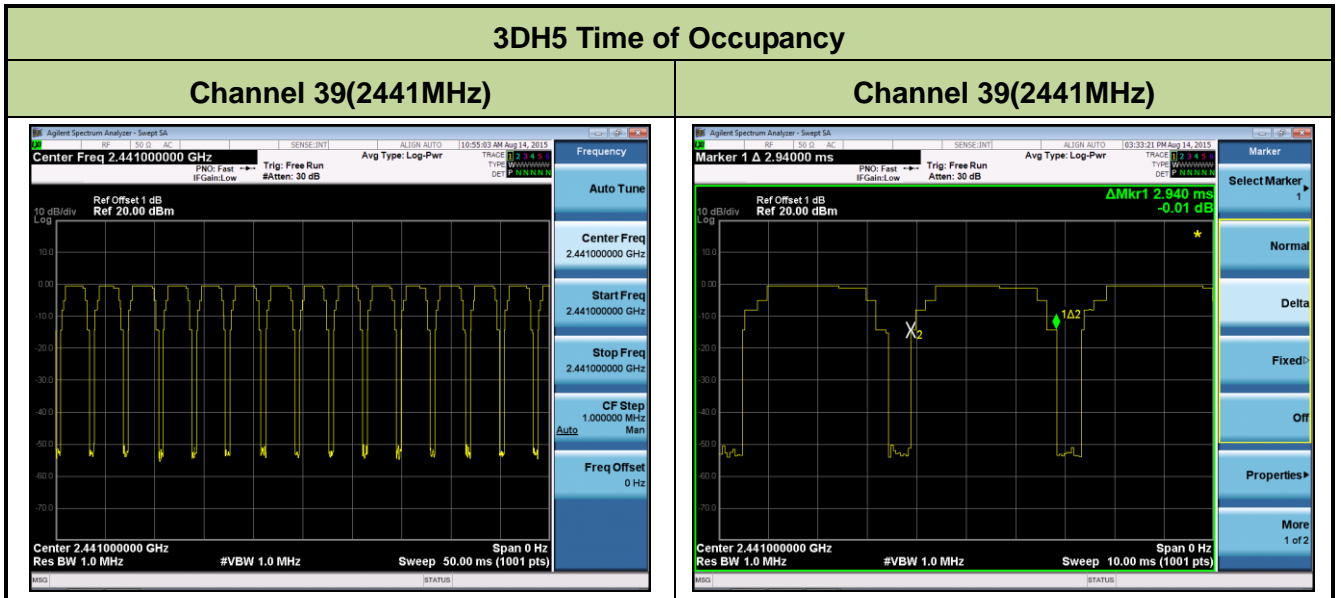

Note: Test Time Period: $0.4 * 79 = 31.6$ sec, Hopping Times Within 1sec: $15/50$ msec=300 hops/sec.

The Maximum Occupancy Time within 31.6sec: $[(2.940\text{ms} * 300) / 79] * 31.6 = 352.80$

7.7. Band-edge Compliance Measurement

7.7.1. Test Limit

The maximum permissible emission level is 20dBc. Any emissions were lying outside of the emission bandwidth and in authorized band edges to a field strength limit specified in Section 15.209 of the Title 47 CFR.

7.7.2. Test Procedure Used

ANSI C63.10-2013 - Section 6.10.4

7.7.3. Test Setting

1. Span = wide enough to capture the peak level of the emission operating on the channel closest to the band edge, as well as any modulation products which fall outside of the authorized band of operation.
2. RBW \geq 1% of spectrum analyzer display span
3. VBW \geq RBW
4. Detector = peak
5. Sweep time = auto couple
6. Trace mode = max hold
7. Trace was allowed to stabilize

Allow the trace to stabilize. Set the marker on the emission at the band edge, or on the highest modulation product outside of the band, if this level is greater than that at the band edge. Enable the marker-delta function, then use the marker-to-peak function to move the marker to the peak of the in-band emission.

7.7.4. Test Setup

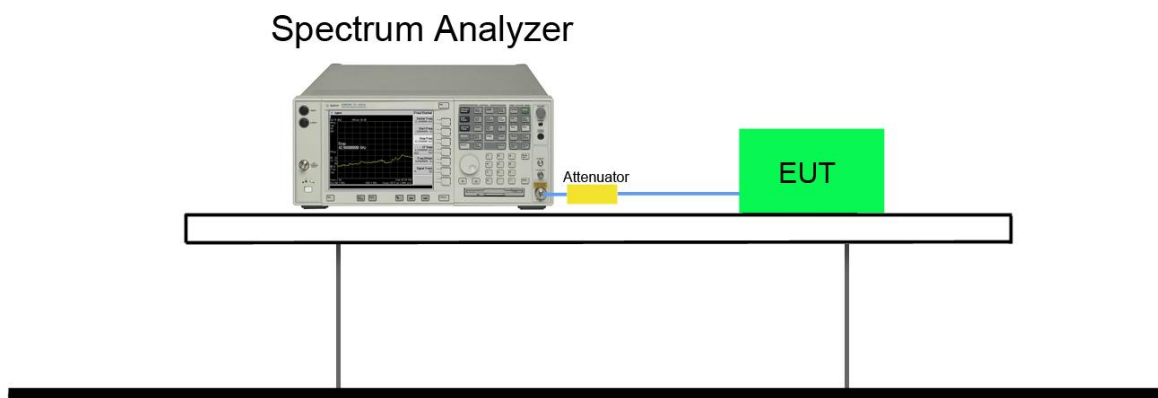

7.7.5. Test Result

Test Mode	Channel No.	Frequency (MHz)	Limit	Result
DH5	00	2402	20dBc	Pass
DH5	78	2480	20dBc	Pass
2DH5	00	2402	20dBc	Pass
2DH5	78	2480	20dBc	Pass
3DH5	00	2402	20dBc	Pass
3DH5	78	2480	20dBc	Pass

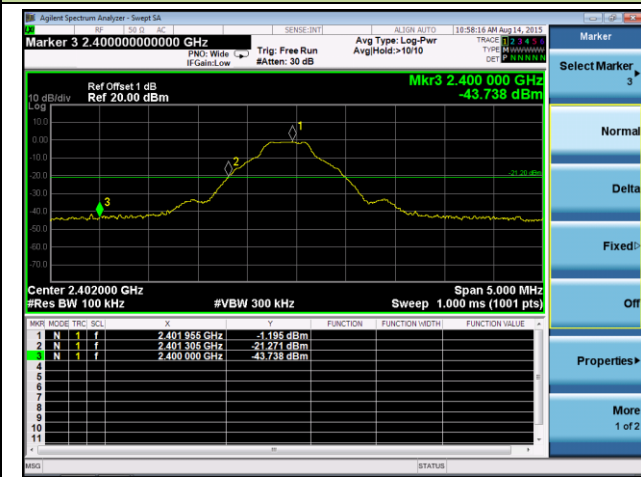
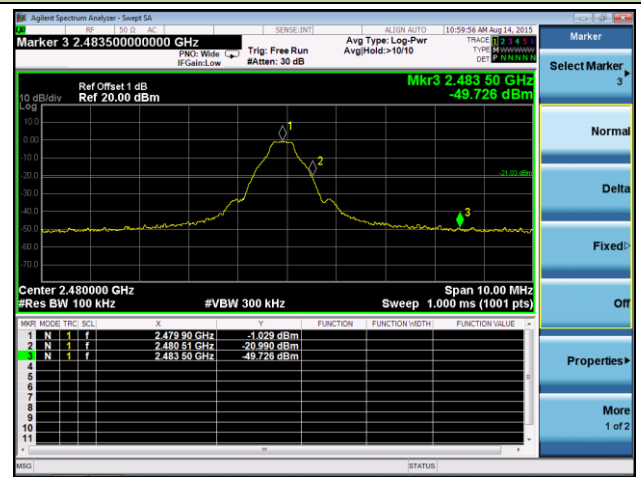
DH5 Band-edge Compliance
Channel 00 (2402MHz)

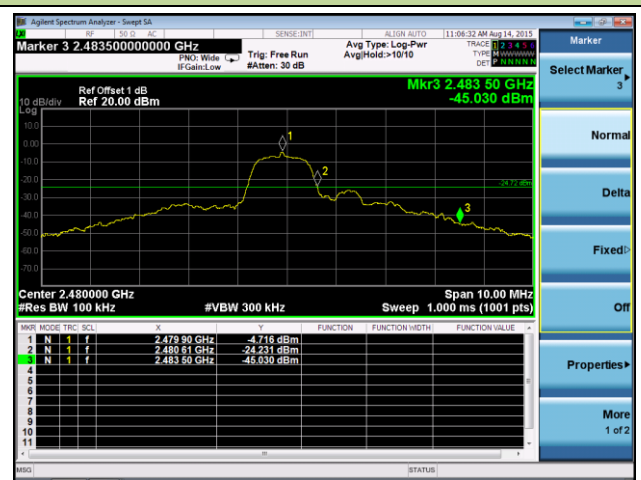
Channel 78 (2480MHz)

2DH5 Band-edge Compliance
Channel 00 (2402MHz)

Channel 78 (2480MHz)

3DH5 Band-edge Compliance

Channel 00 (2402MHz)



Channel 78 (2480MHz)

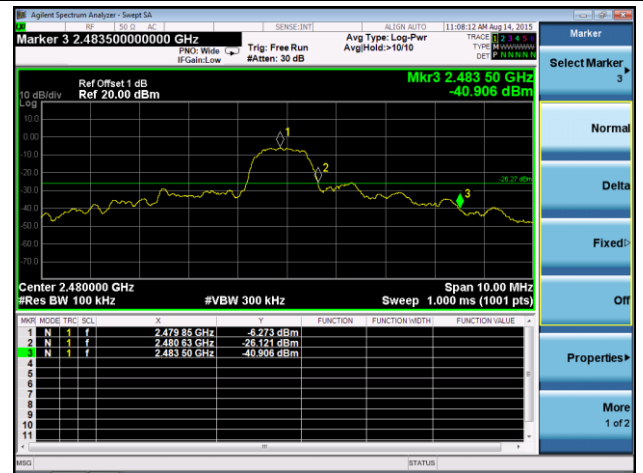

DH5 Operation Frequency Range of 20dB Bandwidth within Hopping Mode

Channel 00 (2402MHz)

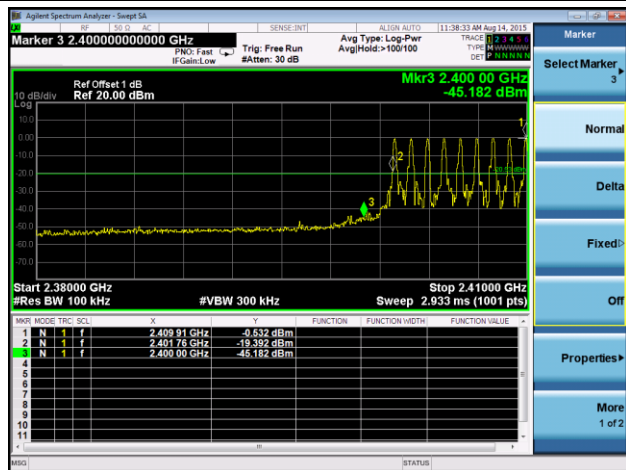

Channel 78 (2480MHz)

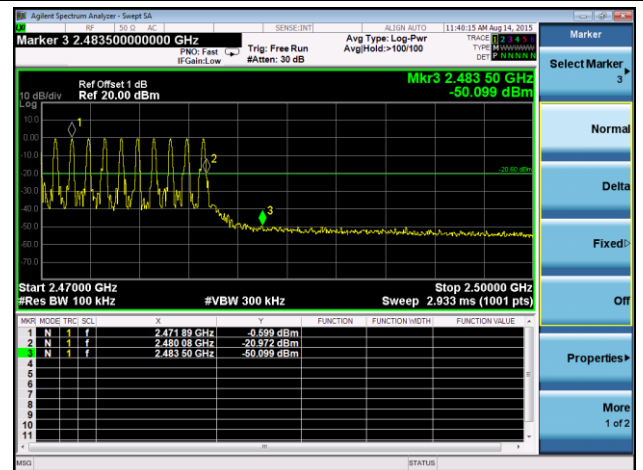

2DH5 Operation Frequency Range of 20dB Bandwidth within Hopping Mode

Channel 00 (2402MHz)

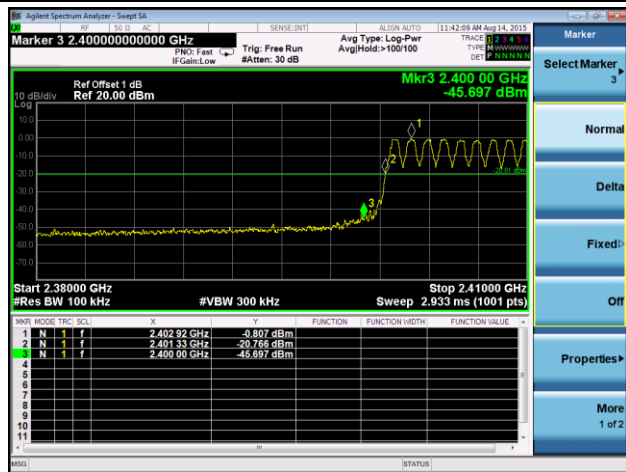

Channel 78 (2480MHz)

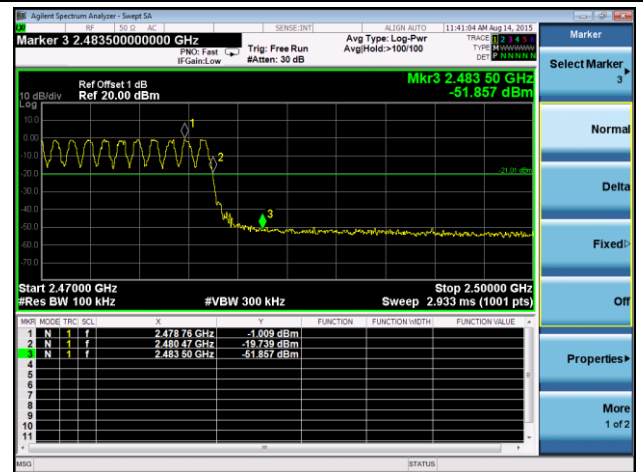

3DH5 Operation Frequency Range of 20dB Bandwidth within Hopping Mode

Channel 00 (2402MHz)

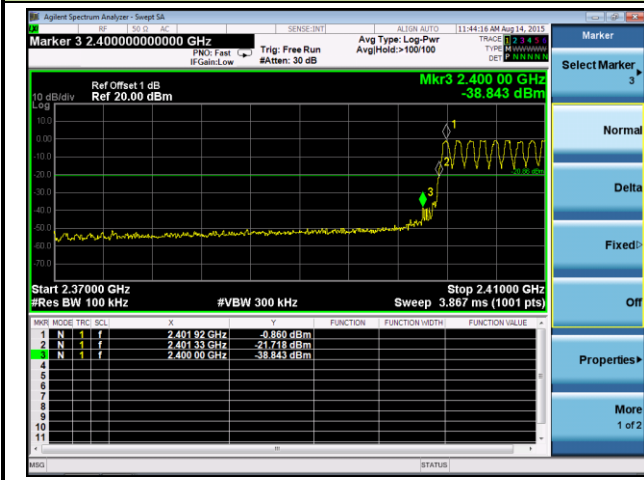

Channel 78 (2480MHz)

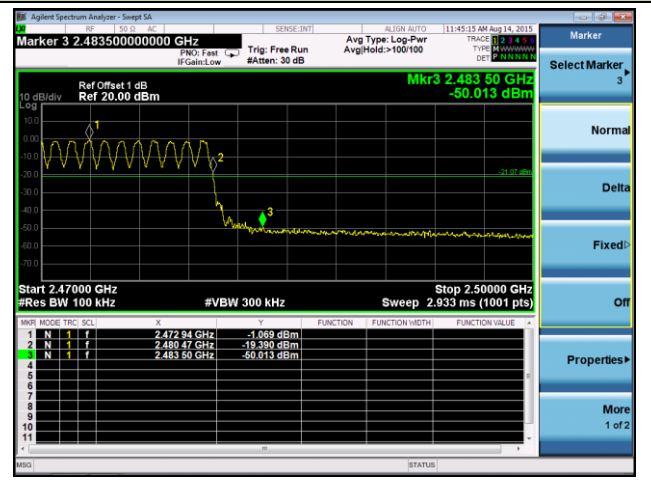

7.8. Conducted Spurious Emissions Measurement

7.8.1. Test Limit

In any 100 kHz bandwidth outside the frequency band in which the spread spectrum or digitally modulated intentional radiator is operating, the radio frequency power that is produced by the intentional radiator shall be at least 20 dB below that in the 100 kHz bandwidth within the band that contains the highest level of the desired power, based on either an RF conducted or a radiated measurement, provided the transmitter demonstrates compliance with the peak conducted or a radiated measurement, provided the transmitter demonstrates compliance with the peak conducted power limits. If the transmitter complies with the conducted power limits based on the use of RMS averaging over a time interval, the attenuation required under this paragraph shall be 30 dB instead of 20 dB.

7.8.2. Test Procedure Used

ANSI C63.10-2013 - Section 7.8.8

7.8.3. Test Setting

1. Span = wide enough to capture the peak level of the in-band emission and all spurious emissions (e.g., harmonics) from the lowest frequency generated in the EUT up through the 10th harmonic. Typically, several plots are required to cover this entire span.
2. RBW = 100 KHz
3. VBW \geq RBW
4. Detector = peak
5. Sweep time = auto couple
6. Trace mode = max hold
7. Trace was allowed to stabilize

Set the marker on the peak of any spurious emission recorded. The level displayed must comply with the limit specified in this section.

7.8.4. Test Setup

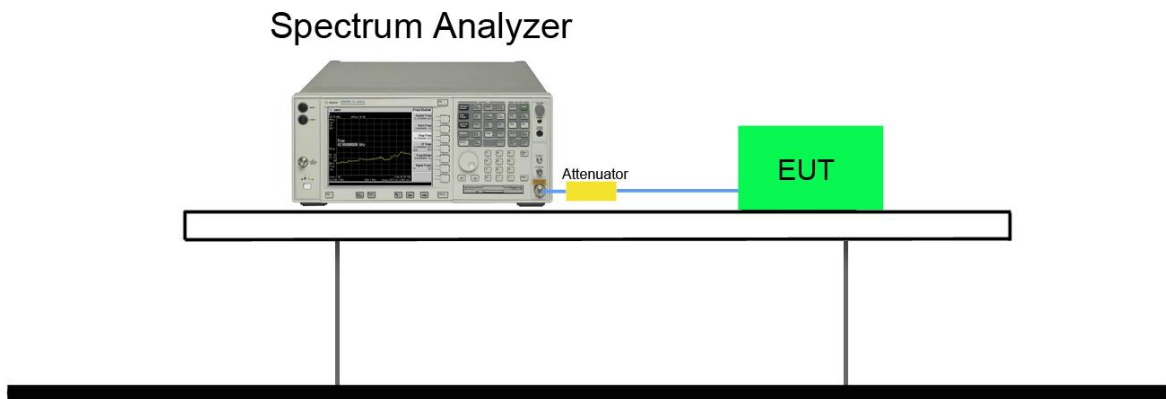

7.8.5. Test Result

Test Mode	Channel No.	Frequency (MHz)	Limit (MHz)	Result
DH5	00	2402	20dBc	Pass
DH5	39	2441	20dBc	Pass
DH5	78	2480	20dBc	Pass
2DH5	00	2402	20dBc	Pass
2DH5	39	2441	20dBc	Pass
2DH5	78	2480	20dBc	Pass
3DH5	00	2402	20dBc	Pass
3DH5	39	2441	20dBc	Pass
3DH5	78	2480	20dBc	Pass

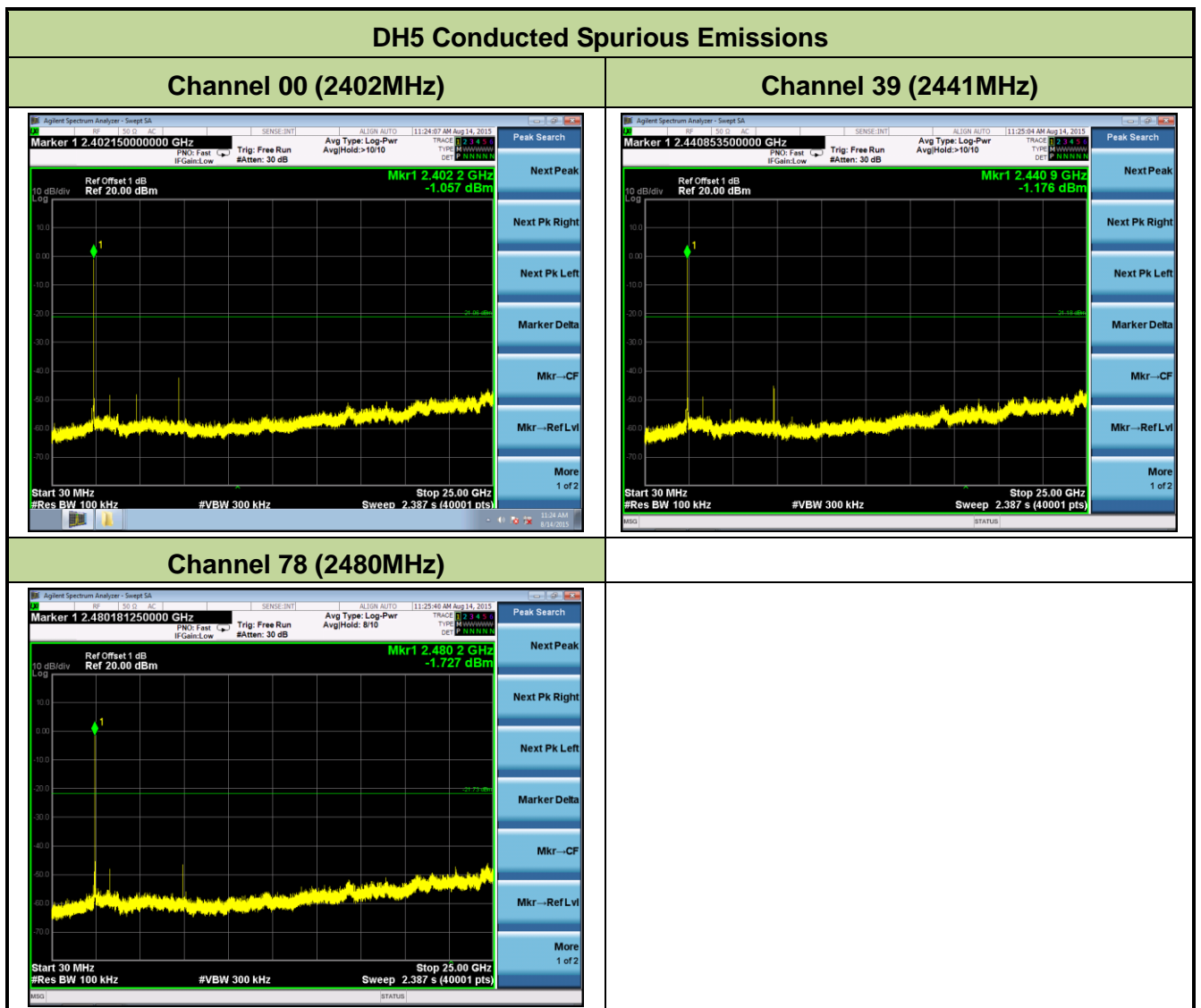

2DH5 Conducted Spurious Emissions

Channel 00 (2402MHz)

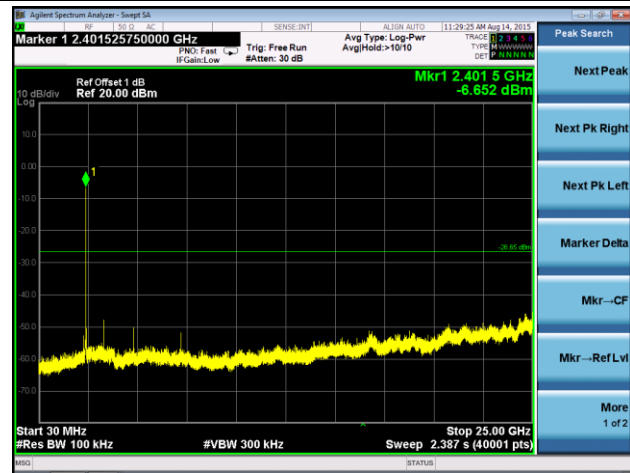

Channel 39 (2441MHz)

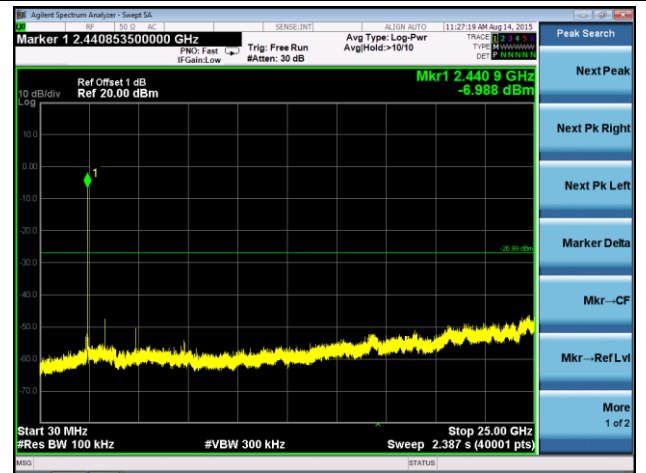

Channel 78 (2480MHz)

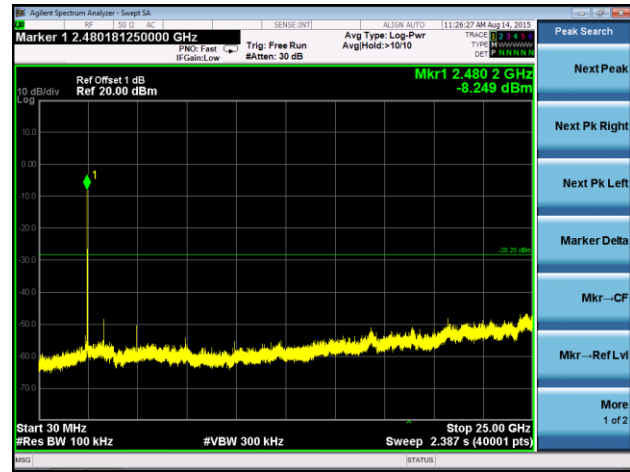

3DH5 Conducted Spurious Emissions

Channel 00 (2402MHz)

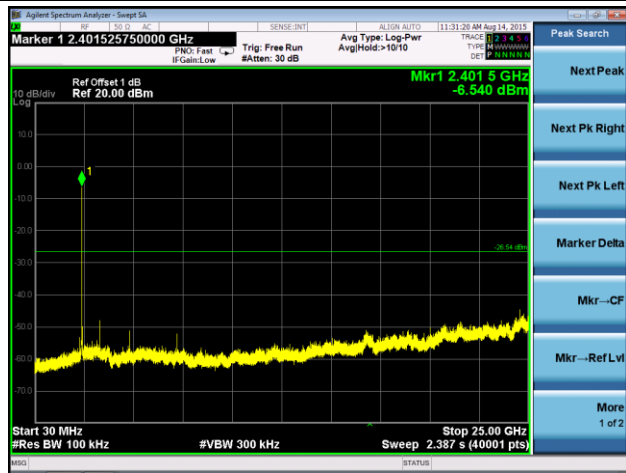

Channel 39 (2441MHz)

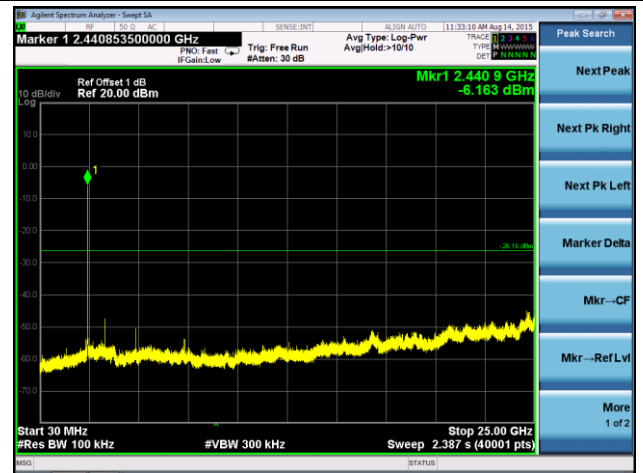

Channel 78 (2480MHz)

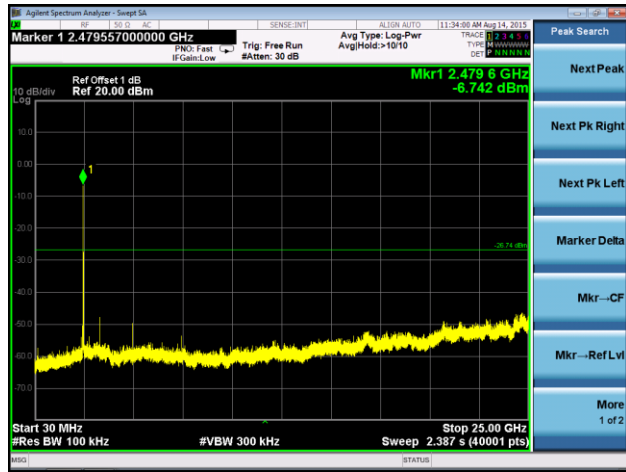

7.9. Radiated Spurious Emission Measurement

7.9.1. Test Limit

All out of band emissions appearing in a restricted band as specified in Section 15.205 of the Title 47 CFR must not exceed the limits shown in Table per Section 15.209.

FCC Part 15 Subpart C Paragraph 15.209		
Frequency [MHz]	Field Strength [V/m]	Measured Distance [Meters]
0.009 - 0.490	2400/F (kHz)	300
0.490 - 1.705	24000/F (kHz)	30
1.705 – 30	30	30
30 – 88	100	3
88 – 216	150	3
216 – 960	200	3
Above 960	500	3

7.9.2. Test Procedure Used

ANSI C63.10-2013 - Section 11.12.1

7.9.3. Test Setting

Peak Field Strength Measurements

1. Analyzer center frequency was set to the frequency of the radiated spurious emission of interest
2. RBW = as specified in Table 1
3. VBW = 3 * RBW
4. Detector = peak
5. Sweep time = auto couple
6. Trace mode = max hold
7. Trace was allowed to stabilize

Table 1 - RBW as a function of frequency

Frequency	RBW
9 ~ 150 kHz	200 ~ 300 Hz
0.15 ~ 30 MHz	9 ~ 10 kHz
30 ~ 1000 MHz	100 ~ 120 kHz
> 1000 MHz	1 MHz

Average Field Strength Measurements

1. Analyzer center frequency was set to the frequency of the radiated spurious emission of interest
2. RBW = 1MHz
3. VBW $\geq 1/T$
4. De As an alternative, the instrument may be set to linear detector mode. Ensure that video filtering is applied in linear voltage domain (rather than in a log or dB domain). Some instruments require linear display mode in order to accomplish this. Others have a setting for Average-VBW Type, which can be set to "Voltage" regardless of the display mode
5. Detector = Peak
6. Sweep time = auto
7. Trace mode = max hold
8. Allow max hold to run for at least 50 times (1/duty cycle) traces

7.9.4. Test Setup

9kHz ~ 30MHz Test Setup:

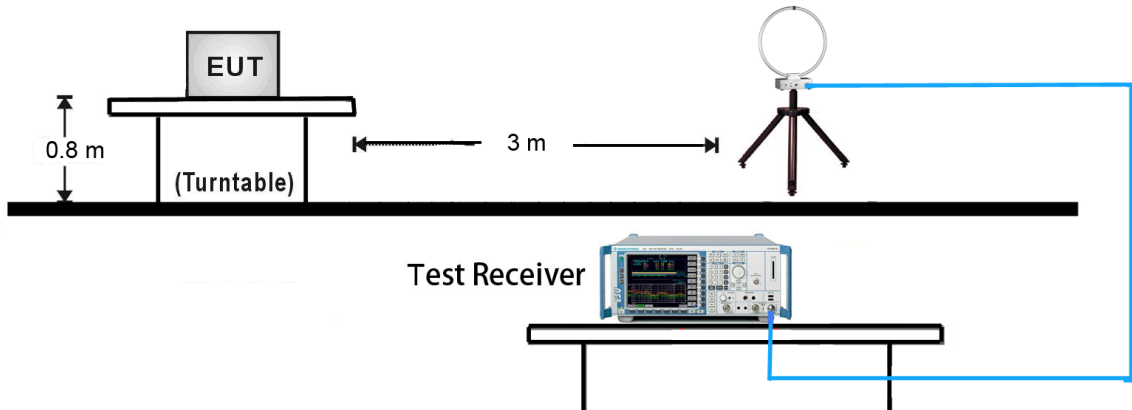

30MHz ~ 1GHz Test Setup:

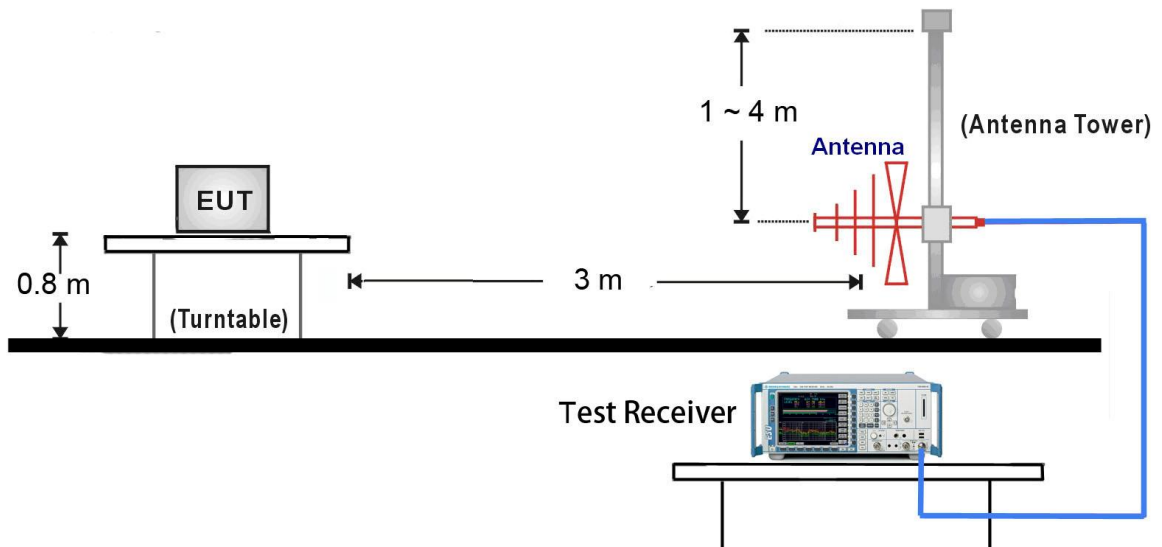

1GHz ~ 25GHz Test Setup:

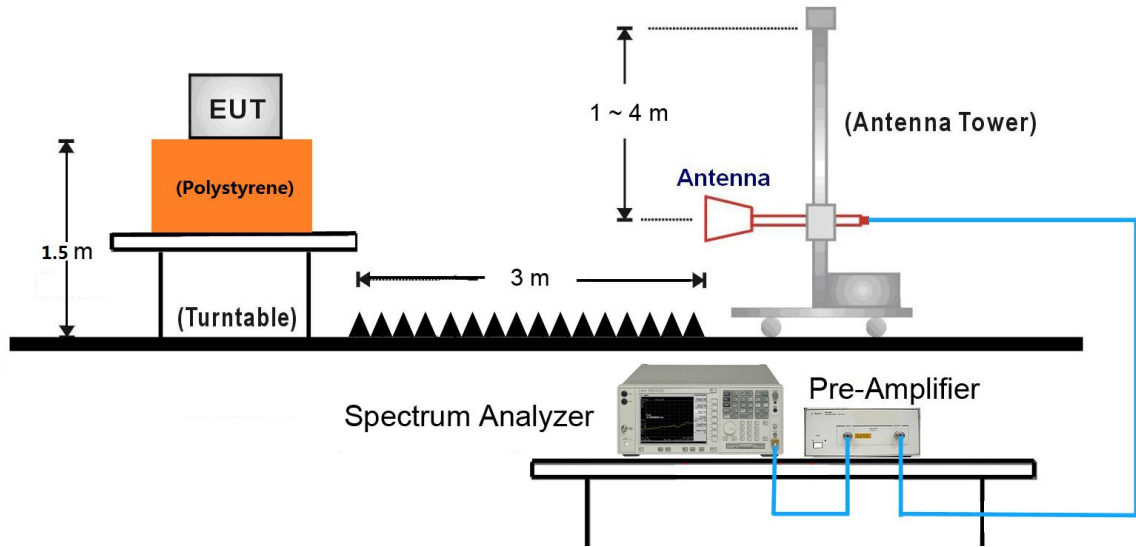

7.9.5. Test Result

Test Mode:	3DH5	Test Site:	AC1
Test Channel:	78	Test Engineer:	Line Chen
Remark:	1. Average measurement was not performed if peak level lower than average limit. 2. The worst case of Radiated Spurious Emission. 3. Other frequency was 20dB below limit line within 1-18GHz, there is not show in the report.		

Mark	Frequency (MHz)	Reading Level (dB μ V)	Factor (dB)	Measure Level (dB μ V/m)	Limit (dB μ V/m)	Margin (dB)	Detector	Polarization
	4791.0	35.4	2.7	38.1	74.0	-35.9	Peak	Horizontal
*	6516.5	34.5	6.0	40.5	75.1	-34.6	Peak	Horizontal
	8276.0	36.0	8.1	44.1	74.0	-29.9	Peak	Horizontal
*	9891.0	33.7	11.6	45.3	75.1	-29.8	Peak	Horizontal
	4808.0	35.7	2.7	38.4	74.0	-35.6	Peak	Vertical
*	6491.0	35.4	5.9	41.3	75.1	-33.8	Peak	Vertical
	8242.0	34.0	8.1	42.1	74.0	-31.9	Peak	Vertical
*	9865.5	33.4	11.6	45.0	75.1	-30.1	Peak	Vertical

Note 1: "*" is not in restricted band, its limit is 20dBc of the fundamental emission level (95.1dB μ V/m) or 15.209 which is higher.

Note 2: Measure Level (dB μ V/m) = Reading Level (dB μ V) + Factor (dB).

Factor (dB) = Cable Loss (dB) + Antenna Factor (dB/m) - Pre_Amplifier Gain (dB).

The worst case of Radiated Emission 9KHz ~ 1GHz and 18GHz ~ 25GHz:

Site: AC1	Time: 2015/08/13 - 23:05
Limit: FCC_Part15.209_RE(3m)	Engineer: Line Chen
Probe: VULB9162_0.03-8GHz	Polarity: Horizontal
EUT: Bluetooth Headset	Power: By Battery
Worse Case Mode: Transmit at Channel 2480MHz by 3DH5	

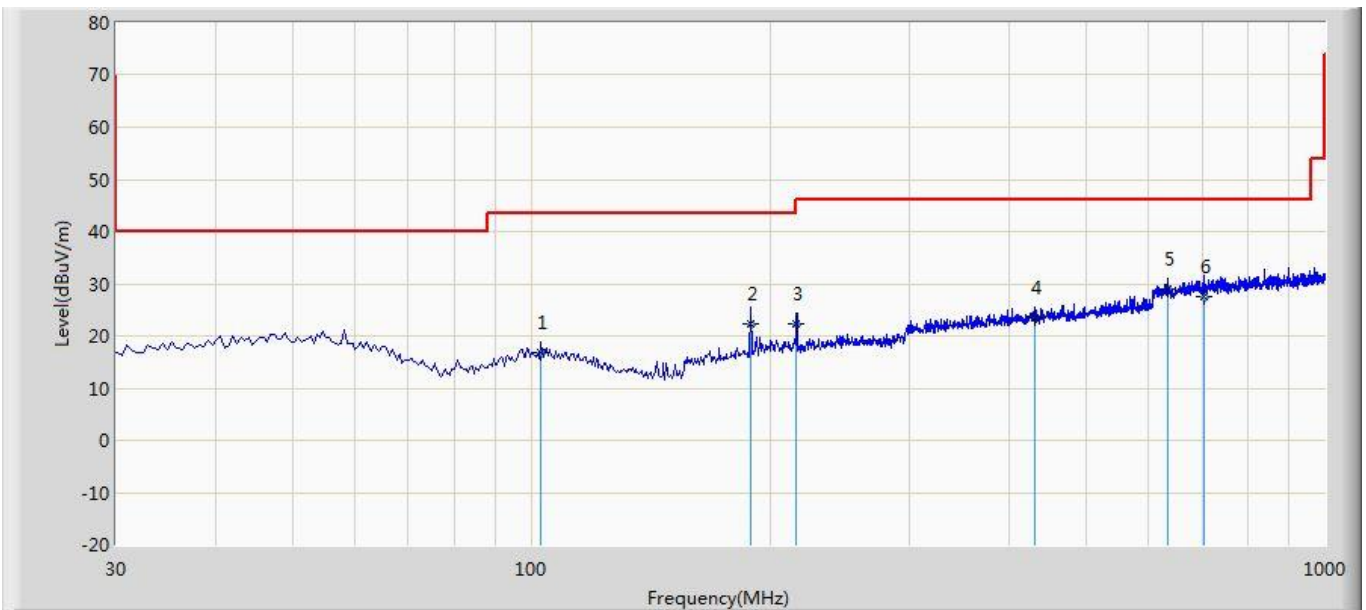

No	Mark	Frequency (MHz)	Measure Level (dBuV/m)	Reading Level (dBuV)	Over Limit (dB)	Limit (dBuV/m)	Factor (dB)	Type
1		102.750	16.700	4.407	-26.800	43.500	12.293	QP
2		189.080	22.281	11.739	-21.219	43.500	10.542	QP
3		215.755	22.207	10.934	-21.293	43.500	11.273	QP
4		430.125	23.536	8.210	-22.464	46.000	15.326	QP
5	*	635.280	28.943	10.691	-17.057	46.000	18.252	QP
6		704.150	27.503	8.207	-18.497	46.000	19.296	QP

Note: Measure Level (dB μ V/m) = Reading Level (dB μ V) + Factor (dB)

Factor (dB) = Cable Loss (dB) + Antenna Factor (dB/m)

Site: AC1	Time: 2015/08/13 - 23:06
Limit: FCC_Part15.209_RE(3m)	Engineer: Line Chen
Probe: VULB9162_0.03-8GHz	Polarity: Vertical
EUT: Bluetooth Headset	Power: By Battery
Worse Case Mode: Transmit at Channel 2480MHz by 3DH5	

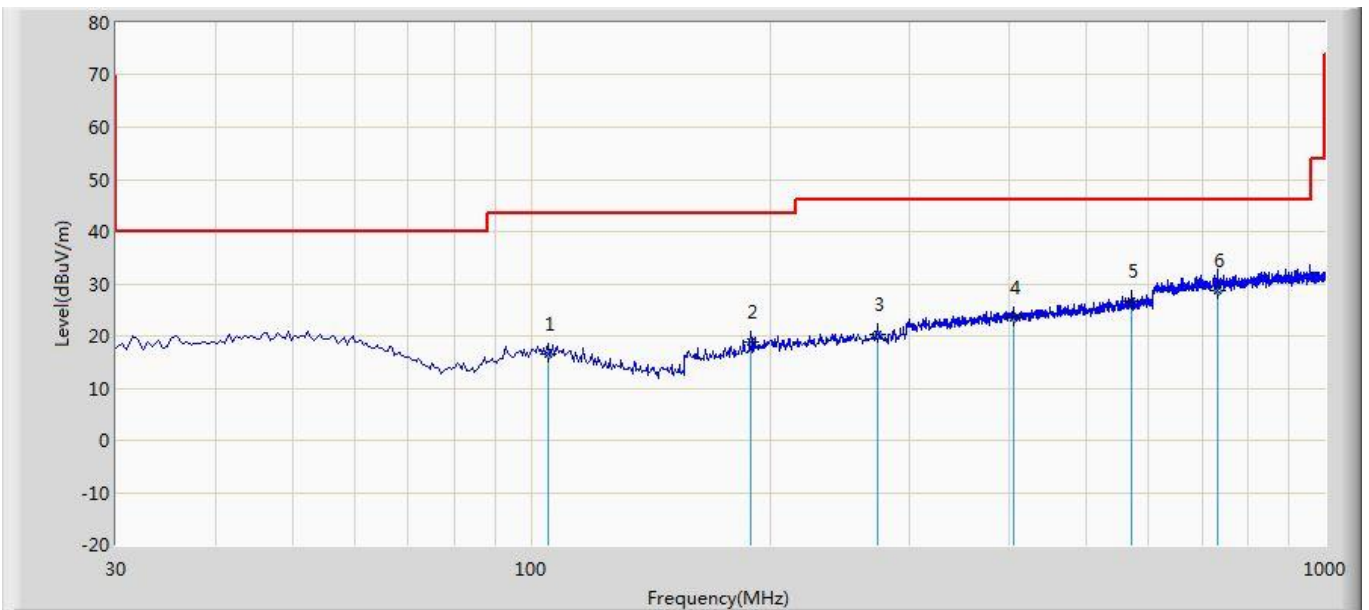

No	Mark	Frequency (MHz)	Measure Level (dBuV/m)	Reading Level (dBuV)	Over Limit (dB)	Limit (dBuV/m)	Factor (dB)	Type
1		105.175	16.499	4.290	-27.001	43.500	12.209	QP
2		189.080	18.787	8.245	-24.713	43.500	10.542	QP
3		272.985	20.235	7.574	-25.765	46.000	12.661	QP
4		404.905	23.468	8.419	-22.532	46.000	15.049	QP
5		571.745	26.552	9.061	-19.448	46.000	17.491	QP
6	*	731.795	28.584	8.956	-17.416	46.000	19.628	QP

Note: Measure Level (dB μ V/m) = Reading Level (dB μ V) + Factor (dB)

Factor (dB) = Cable Loss (dB) + Antenna Factor (dB/m)

Site: AC1	Time: 2015/08/13 - 15:34
Limit: FCC_Part15.209_RE(3m)	Engineer: Line Chen
Probe: FMZB1519_0.009-30MHz	Polarity: Face On
EUT: Bluetooth Headset	Power: By Battery
Note: There is the ambient noise within frequency range 9kHz~30MHz.	

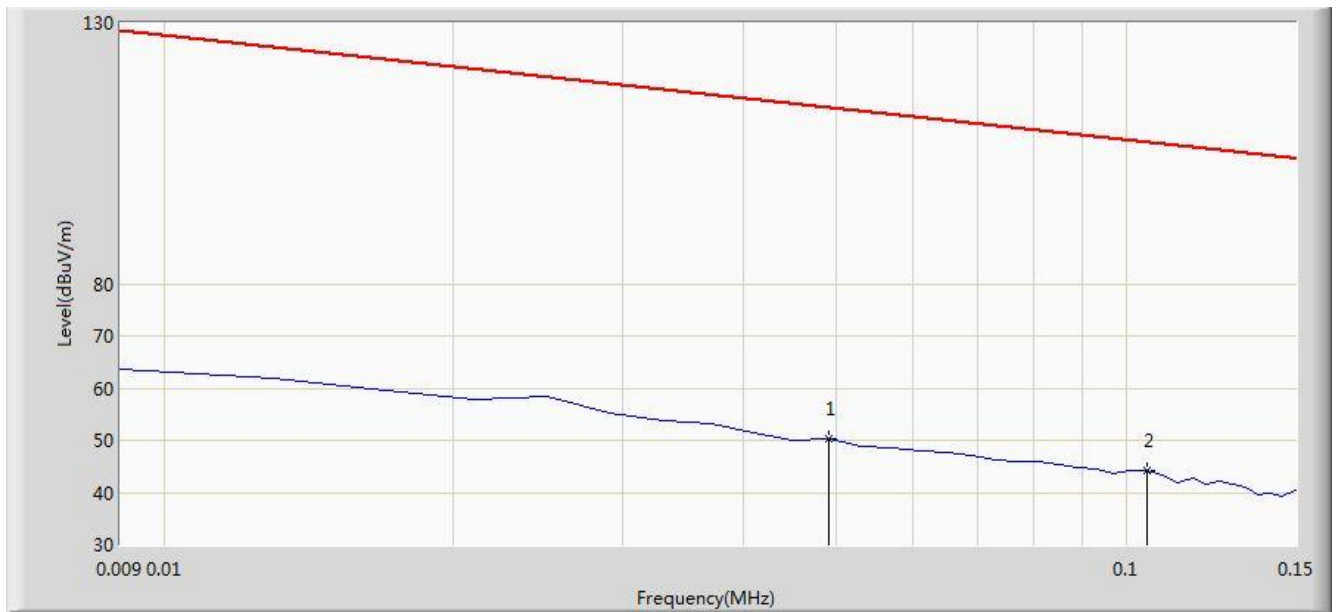

No	Flag	Mark	Frequency (MHz)	Measure Level (dBuV/m)	Reading Level (dBuV)	Over Limit (dB)	Limit (dBuV/m)	Factor (dB)	Type
1			0.049	50.367	29.861	-63.422	113.789	20.505	QP
2		*	0.105	44.143	23.996	-63.029	107.173	20.147	QP

Note: Measure Level (dB μ V/m) = Reading Level (dB μ V) + Factor (dB)

Factor (dB) = Cable Loss (dB) + Antenna Factor (dB/m)

Site: AC1	Time: 2015/08/13 - 15:45
Limit: FCC_Part15.209_RE(3m)	Engineer: Line Chen
Probe: FMZB1519_0.009-30MHz	Polarity: Face On
EUT: Bluetooth Headset	Power: By Battery
Note: There is the ambient noise within frequency range 9kHz~30MHz.	

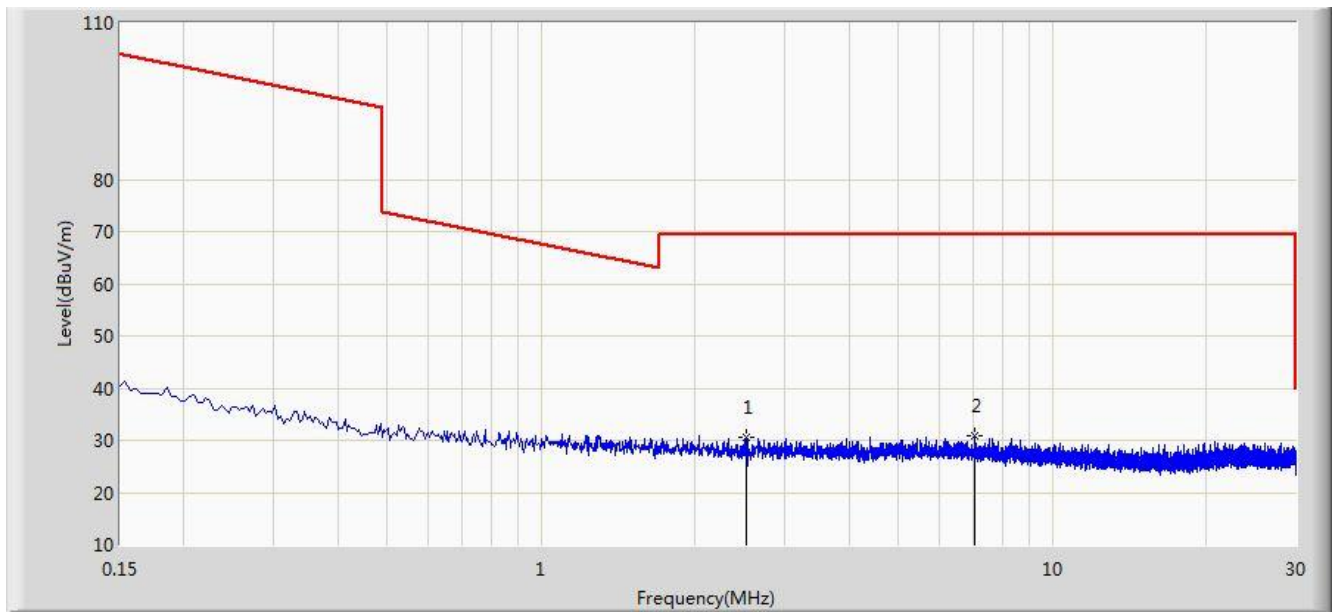

No	Flag	Mark	Frequency (MHz)	Measure Level (dBuV/m)	Reading Level (dBuV)	Over Limit (dB)	Limit (dBuV/m)	Factor (dB)	Type
1			2.513	30.495	10.336	-39.005	69.500	20.159	QP
2		*	7.041	30.974	10.579	-38.526	69.500	20.395	QP

Note: Measure Level (dB μ V/m) = Reading Level (dB μ V) + Factor (dB)

Factor (dB) = Cable Loss (dB) + Antenna Factor (dB/m)

Site: AC1	Time: 2015/08/13 - 15:59
Limit: FCC_Part15.209_RE(3m)	Engineer: Line Chen
Probe: BBHA9170_18-40GHz	Polarity: Horizontal
EUT: Bluetooth Headset	Power: By Battery
Note: There is the ambient noise within frequency range 18GHz~25GHz.	

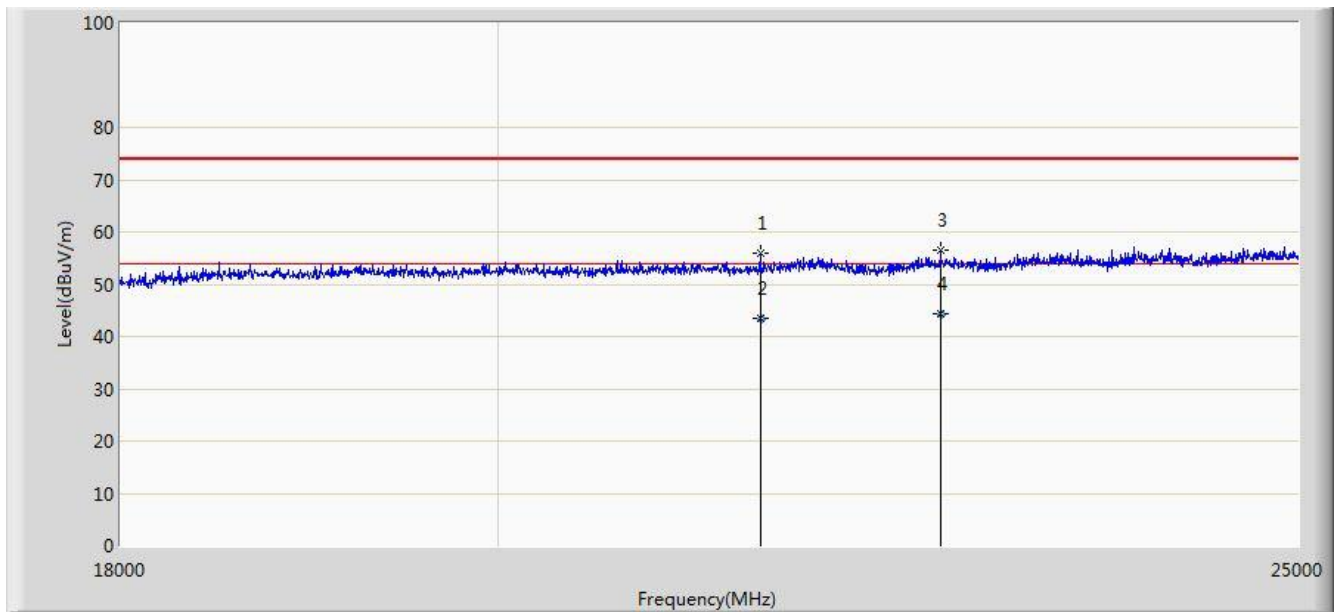

No	Flag	Mark	Frequency (MHz)	Measure Level (dBuV/m)	Reading Level (dBuV)	Over Limit (dB)	Limit (dBuV/m)	Factor (dB)	Type
1			21517.500	55.869	17.883	-18.131	74.000	37.986	PK
2			21517.650	43.351	5.365	-10.649	54.000	37.986	AV
3			22630.500	56.509	18.223	-17.491	74.000	38.286	PK
4		*	22630.540	44.310	6.024	-9.690	54.000	38.286	AV

Note: Measure Level (dB μ V/m) = Reading Level (dB μ V) + Factor (dB)

Factor (dB) = Cable Loss (dB) + Antenna Factor (dB/m) – Pre_Amplifier Gain (dB)

Site: AC1	Time: 2015/08/13 - 16:05
Limit: FCC_Part15.209_RE(3m)	Engineer: Line Chen
Probe: BBHA9170_18-40GHz	Polarity: Vertical
EUT: Bluetooth Headset	Power: By Battery
Note: There is the ambient noise within frequency range 18GHz~25GHz.	

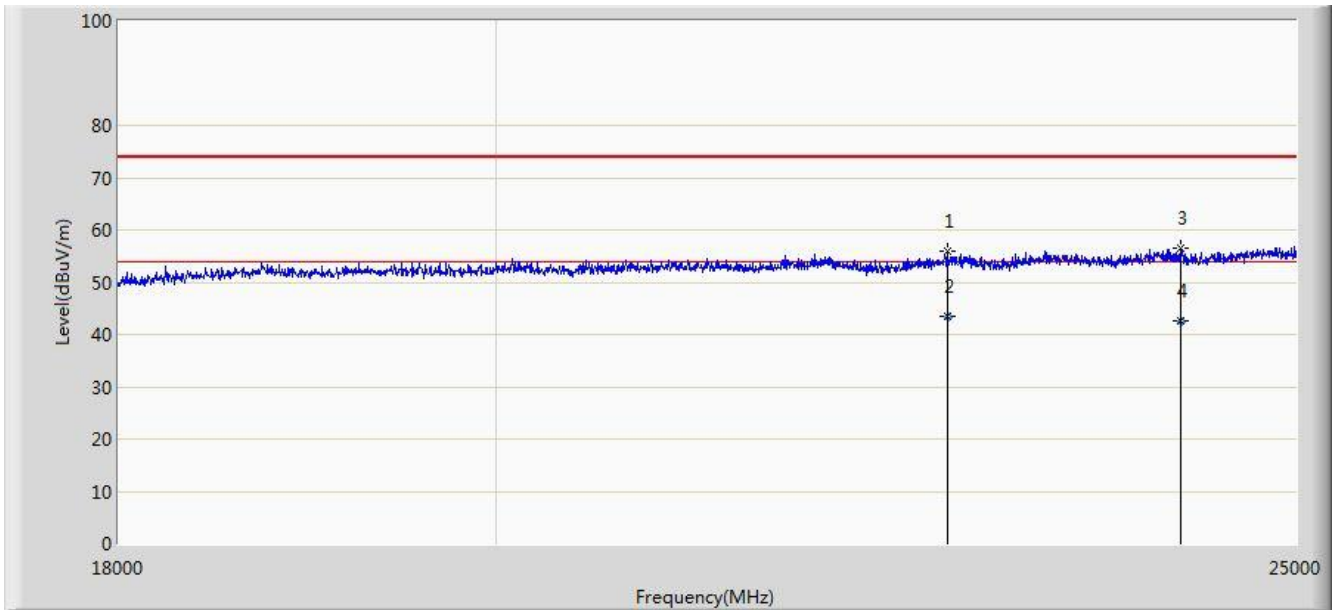

No	Flag	Mark	Frequency (MHz)	Measure Level (dBuV/m)	Reading Level (dBuV)	Over Limit (dB)	Limit (dBuV/m)	Factor (dB)	Type
1			22686.500	55.811	17.457	-18.189	74.000	38.354	PK
2			22686.540	43.598	5.244	-10.402	54.000	38.354	AV
3			24205.500	56.430	17.607	-17.570	74.000	38.823	PK
4		*	24205.658	42.518	3.695	-11.482	54.000	38.823	AV

Note: Measure Level (dB μ V/m) = Reading Level (dB μ V) + Factor (dB)

Factor (dB) = Cable Loss (dB) + Antenna Factor (dB/m) – Pre_Amplifier Gain (dB)

7.10. Radiated Restricted Band Edge Measurement

7.10.1. Test Result

Site: AC1	Time: 2015/08/14 - 00:20
Limit: FCC_Part15.209_RE(3m)	Engineer: Line Chen
Probe: BBHA9120D_1-18GHz	Polarity: Horizontal
EUT: Bluetooth Headset	Power: By Battery
Worst Case Mode: Transmit at Channel 2402MHz by 2DH5	

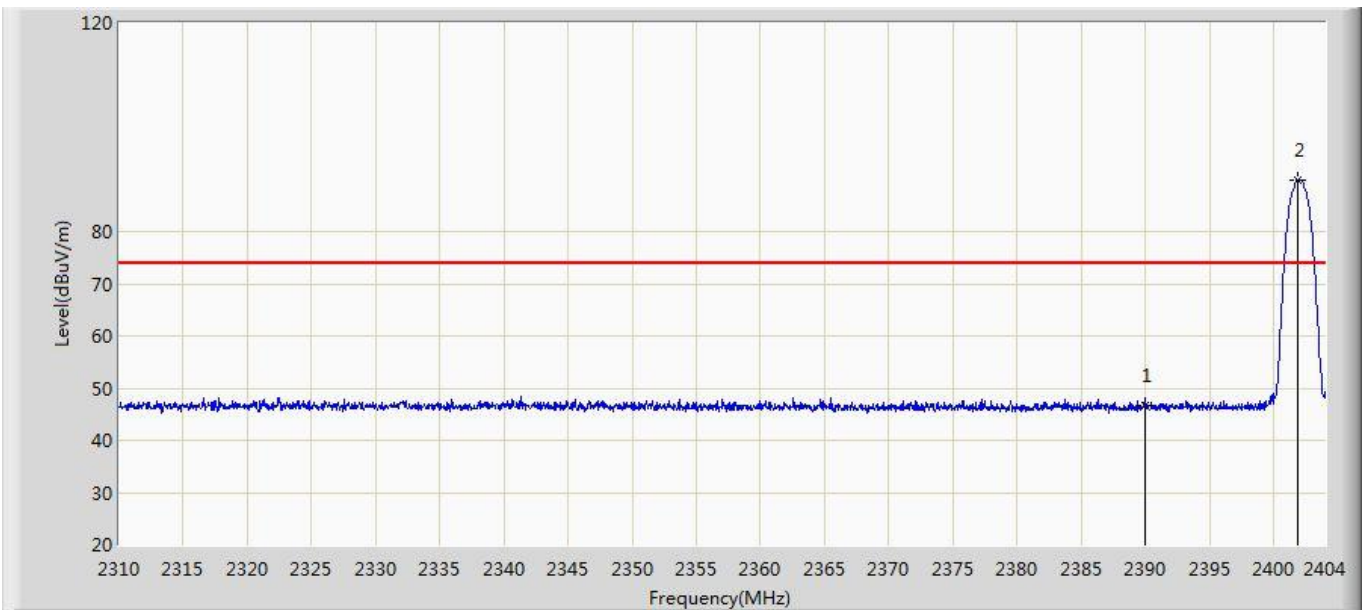

No	Mark	Frequency (MHz)	Measure Level (dBuV/m)	Reading Level (dBuV)	Over Limit (dB)	Limit (dBuV/m)	Factor (dB)	Type
1		2390.000	46.545	15.342	-27.455	74.000	31.203	PK
2	*	2401.885	89.785	58.601	N/A	N/A	31.184	PK

Note: Measure Level (dBuV/m) = Reading Level (dBuV) + Factor (dB)

Factor (dB) = Cable Loss (dB) + Antenna Factor (dB/m)

Site: AC1	Time: 2015/08/14 - 00:23
Limit: FCC_Part15.209_RE(3m)	Engineer: Line Chen
Probe: BBHA9120D_1-18GHz	Polarity: Horizontal
EUT: Bluetooth Headset	Power: By Battery
Worst Case Mode: Transmit at Channel 2402MHz by 2DH5	

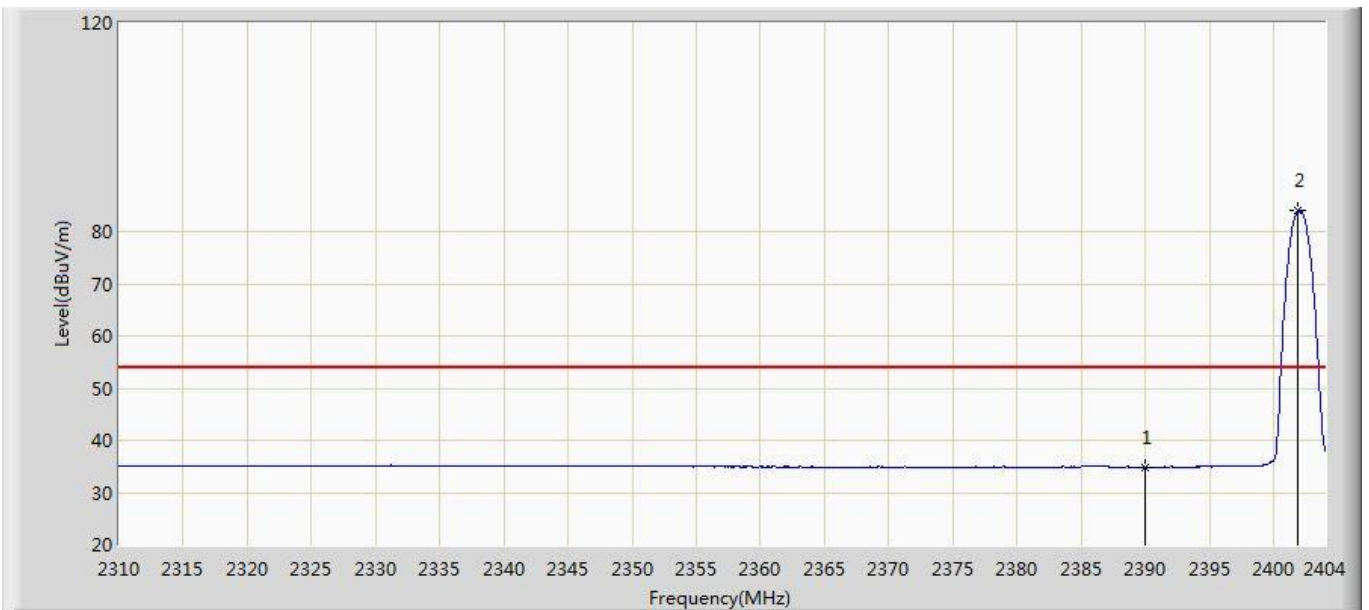

No	Mark	Frequency (MHz)	Measure Level (dBuV/m)	Reading Level (dBuV)	Over Limit (dB)	Limit (dBuV/m)	Factor (dB)	Type
1		2390.000	34.843	3.640	-19.157	54.000	31.203	AV
2	*	2401.885	83.927	52.743	N/A	N/A	31.184	AV

Note: Measure Level (dBuV/m) = Reading Level (dBuV) + Factor (dB)

Factor (dB) = Cable Loss (dB) + Antenna Factor (dB/m)

Site: AC1	Time: 2015/08/14 - 00:23
Limit: FCC_Part15.209_RE(3m)	Engineer: Line Chen
Probe: BBHA9120D_1-18GHz	Polarity: Vertical
EUT: Bluetooth Headset	Power: By Battery
Worst Case Mode: Transmit at Channel 2402MHz by 2DH5	

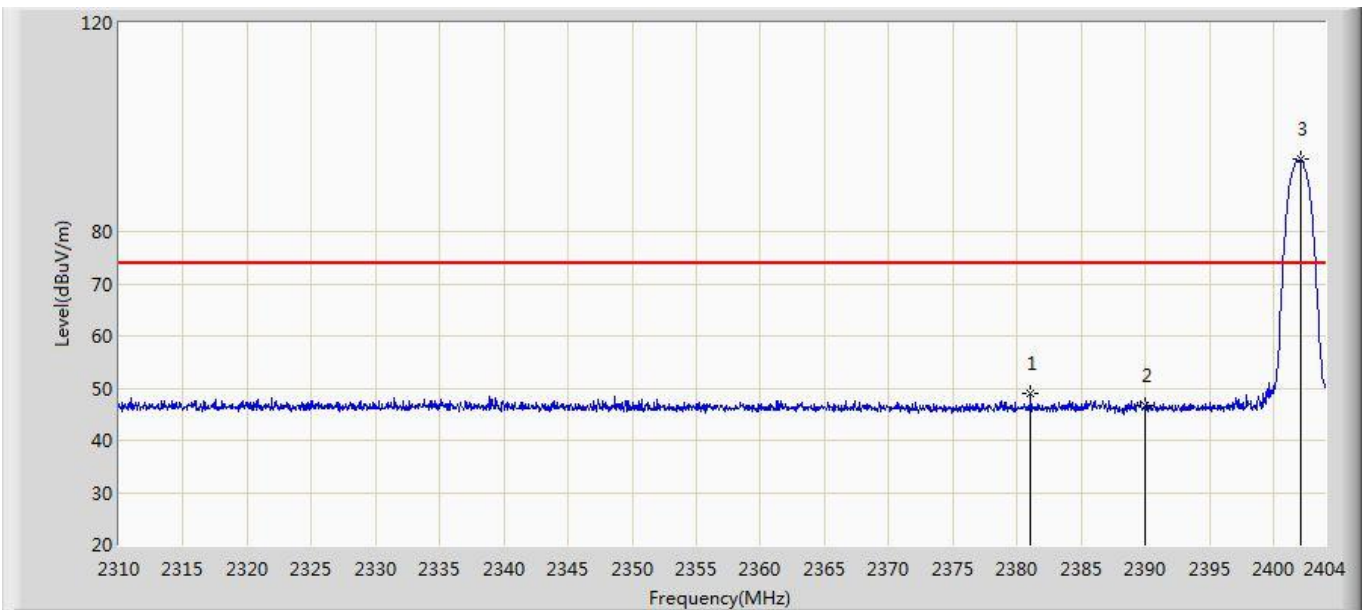

No	Mark	Frequency (MHz)	Measure Level (dBuV/m)	Reading Level (dBuV)	Over Limit (dB)	Limit (dBuV/m)	Factor (dB)	Type
1		2381.064	48.931	17.712	-25.069	74.000	31.219	PK
2		2390.000	46.644	15.441	-27.356	74.000	31.203	PK
3	*	2402.120	93.795	62.611	N/A	N/A	31.184	PK

Note: Measure Level (dB μ V/m) = Reading Level (dB μ V) + Factor (dB)

Factor (dB) = Cable Loss (dB) + Antenna Factor (dB/m)

Site: AC1	Time: 2015/08/14 - 00:25
Limit: FCC_Part15.209_RE(3m)	Engineer: Line Chen
Probe: BBHA9120D_1-18GHz	Polarity: Vertical
EUT: Bluetooth Headset	Power: By Battery
Worst Case Mode: Transmit at Channel 2402MHz by 2DH5	

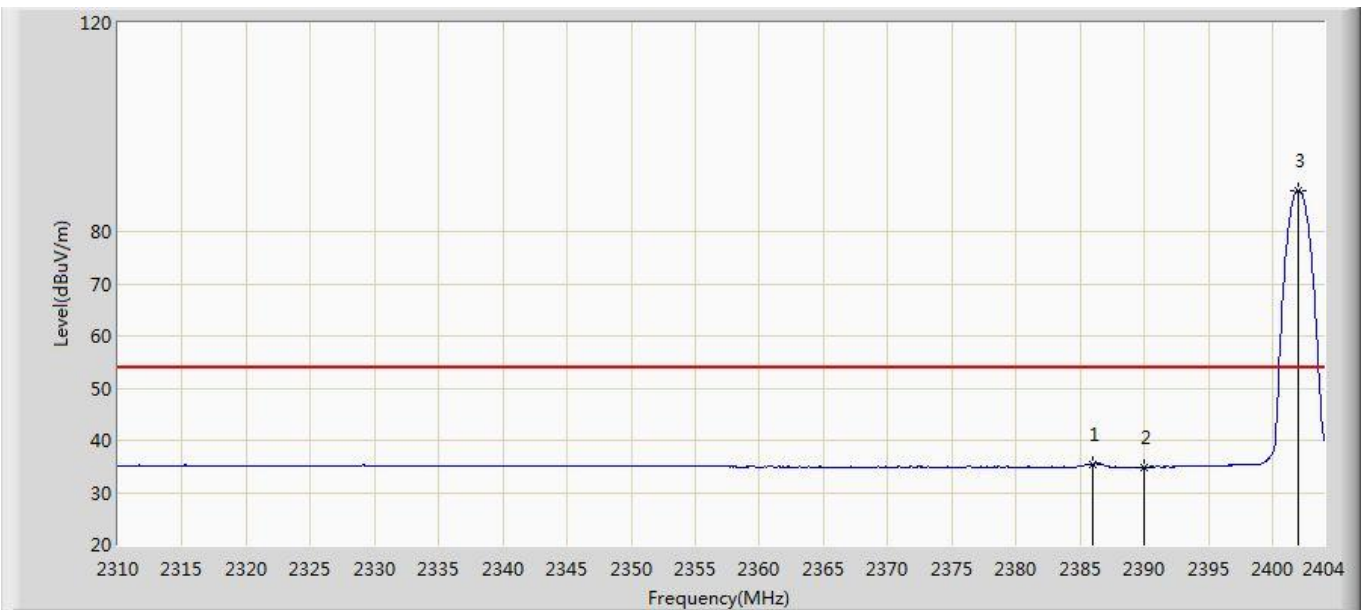

No	Mark	Frequency (MHz)	Measure Level (dBuV/m)	Reading Level (dBuV)	Over Limit (dB)	Limit (dBuV/m)	Factor (dB)	Type
1		2385.952	35.423	4.213	-18.577	54.000	31.210	AV
2		2390.000	34.910	3.707	-19.090	54.000	31.203	AV
3	*	2401.979	87.923	56.739	N/A	N/A	31.184	AV

Note: Measure Level (dBμV/m) = Reading Level (dBμV) + Factor (dB)

Factor (dB) = Cable Loss (dB) + Antenna Factor (dB/m)

Site: AC1	Time: 2015/08/14 - 00:43
Limit: FCC_Part15.209_RE(3m)	Engineer: Line Chen
Probe: BBHA9120D_1-18GHz	Polarity: Horizontal
EUT: Bluetooth Headset	Power: By Battery
Worst Case Mode: Transmit at Channel 2480MHz by 3DH5	

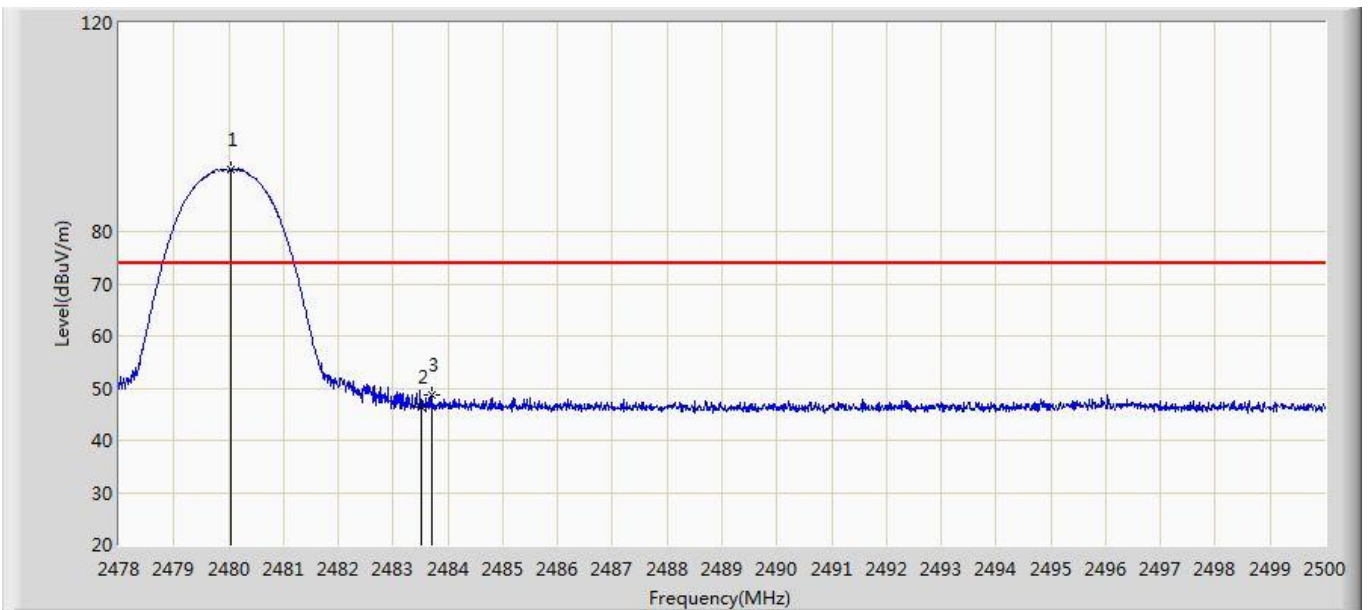

No	Mark	Frequency (MHz)	Measure Level (dBuV/m)	Reading Level (dBuV)	Over Limit (dB)	Limit (dBuV/m)	Factor (dB)	Type
1	*	2480.046	91.936	60.752	N/A	N/A	31.184	PK
2		2483.500	46.396	15.203	-27.604	74.000	31.194	PK
3		2483.709	48.668	17.474	-25.332	74.000	31.194	PK

Note: Measure Level (dB μ V/m) = Reading Level (dB μ V) + Factor (dB)

Factor (dB) = Cable Loss (dB) + Antenna Factor (dB/m)

Site: AC1	Time: 2015/08/14 - 00:45
Limit: FCC_Part15.209_RE(3m)	Engineer: Line Chen
Probe: BBHA9120D_1-18GHz	Polarity: Horizontal
EUT: Bluetooth Headset	Power: By Battery
Worst Case Mode: Transmit at Channel 2480MHz by 3DH5	

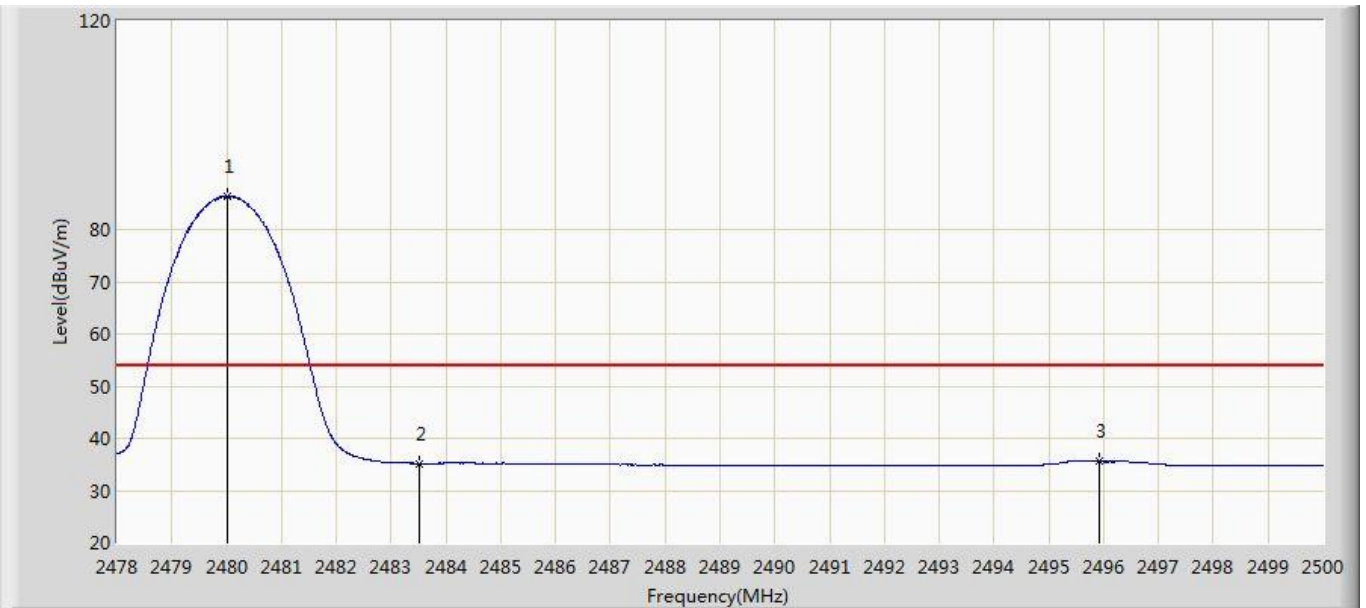

No	Mark	Frequency (MHz)	Measure Level (dBuV/m)	Reading Level (dBuV)	Over Limit (dB)	Limit (dBuV/m)	Factor (dB)	Type
1	*	2480.002	86.378	55.194	N/A	N/A	31.184	AV
2		2483.500	35.187	3.994	-18.813	54.000	31.194	AV
3		2495.919	35.557	4.331	-18.443	54.000	31.226	AV

Note: Measure Level (dB μ V/m) = Reading Level (dB μ V) + Factor (dB)

Factor (dB) = Cable Loss (dB) + Antenna Factor (dB/m)

Site: AC1	Time: 2015/08/14 - 00:46
Limit: FCC_Part15.209_RE(3m)	Engineer: Line Chen
Probe: BBHA9120D_1-18GHz	Polarity: Vertical
EUT: Bluetooth Headset	Power: By Battery
Worst Case Mode: Transmit at Channel 2480MHz by 3DH5	

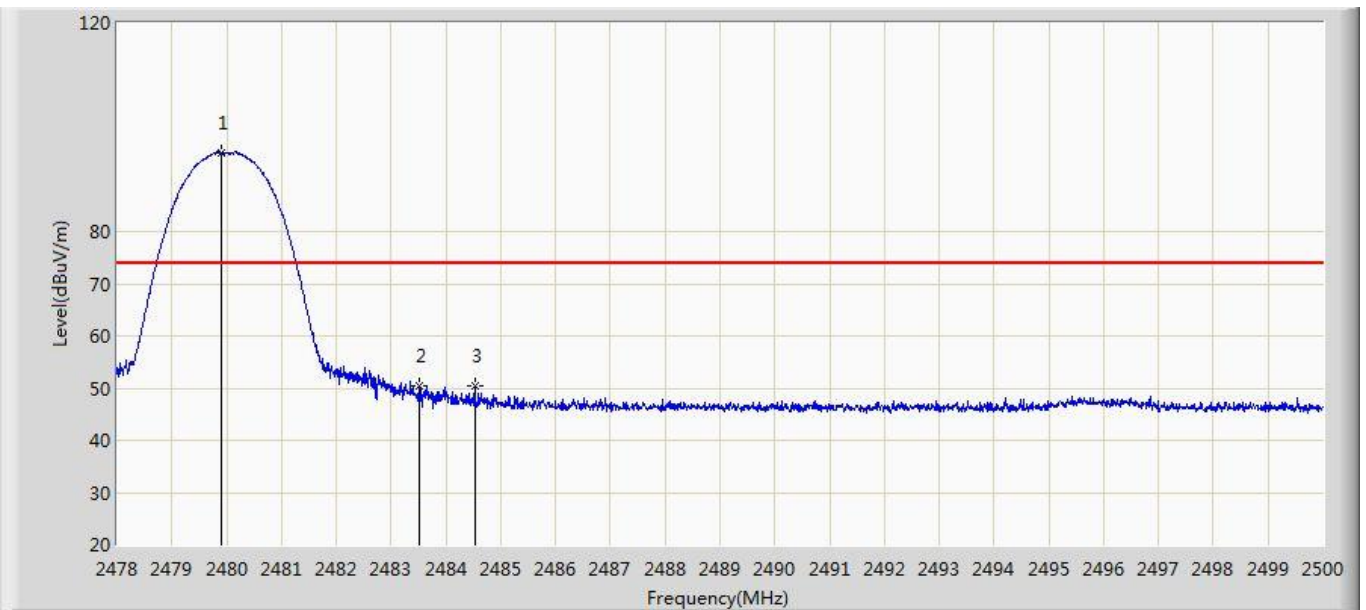

No	Mark	Frequency (MHz)	Measure Level (dBuV/m)	Reading Level (dBuV)	Over Limit (dB)	Limit (dBuV/m)	Factor (dB)	Type
1	*	2479.914	95.072	63.888	N/A	N/A	31.184	PK
2		2483.500	50.388	19.195	-23.612	74.000	31.194	PK
3		2484.523	50.486	19.290	-23.514	74.000	31.196	PK

Note: Measure Level (dB μ V/m) = Reading Level (dB μ V) + Factor (dB)

Factor (dB) = Cable Loss (dB) + Antenna Factor (dB/m)

Site: AC1	Time: 2015/08/14 - 00:48
Limit: FCC_Part15.209_RE(3m)	Engineer: Line Chen
Probe: BBHA9120D_1-18GHz	Polarity: Vertical
EUT: Bluetooth Headset	Power: By Battery
Worst Case Mode: Transmit at Channel 2480MHz by 3DH5	



No	Mark	Frequency (MHz)	Measure Level (dBuV/m)	Reading Level (dBuV)	Over Limit (dB)	Limit (dBuV/m)	Factor (dB)	Type
1	*	2479.969	89.437	58.253	N/A	N/A	31.184	AV
2		2483.500	35.495	4.302	-18.505	54.000	31.194	AV
3		2495.952	35.805	4.579	-18.195	54.000	31.226	AV

Note: Measure Level (dBμV/m) = Reading Level (dBμV) + Factor (dB)

Factor (dB) = Cable Loss (dB) + Antenna Factor (dB/m)

7.11. AC Conducted Emissions Measurement

7.11.1. Test Limit

FCC Part 15 Subpart C Paragraph 15.207 Limits		
Frequency (MHz)	QP (dB μ V)	Average (dB μ V)
0.15 - 0.50	66 - 56	56 - 46
0.50 - 5.0	56	46
5.0 - 30	60	50

Note 1: The lower limit shall apply at the transition frequencies.

Note 2: The limit decreases linearly with the logarithm of the frequency in the range 0.15MHz to 0.5MHz.

7.11.2. Test Setup

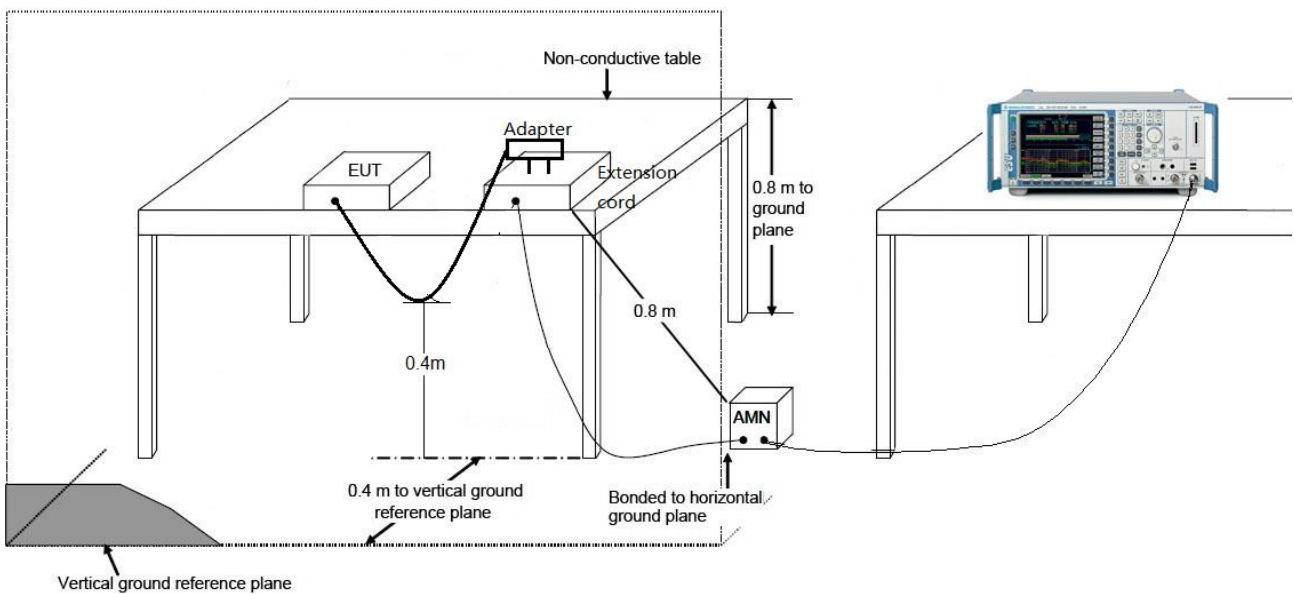

7.11.3. Test Result

Site: SR2	Time: 2015/08/17 - 13:41
Limit: FCC_Part15.207_CE_AC Power	Engineer: Line Chen
Probe: ENV216_101683_Filter On	Polarity: Line
EUT: Bluetooth Headset	Power: AC 120V/60Hz
Note: Mode1	

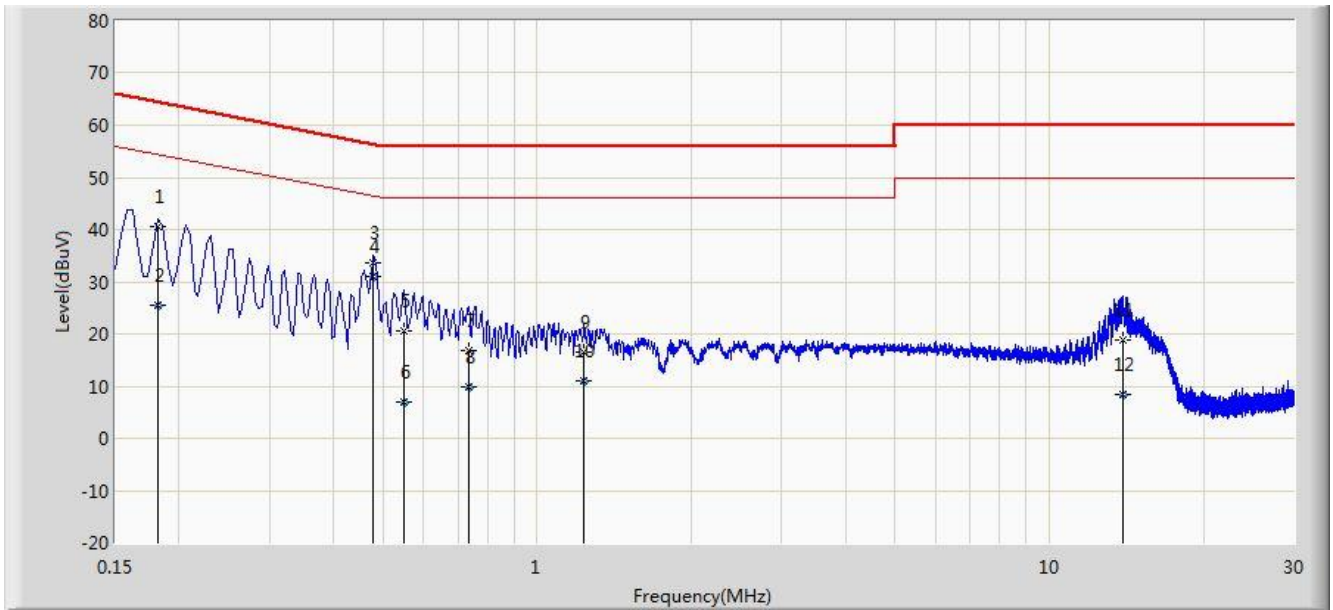

No	Flag	Mark	Frequency (MHz)	Measure Level (dBuV)	Reading Level (dBuV)	Over Limit (dB)	Limit (dBuV)	Factor (dB)	Type
1			0.182	40.552	30.504	-23.842	64.394	10.048	QP
2			0.182	25.582	15.533	-28.812	54.394	10.048	AV
3			0.478	33.741	23.593	-22.633	56.374	10.149	QP
4		*	0.478	30.971	20.823	-15.403	46.374	10.149	AV
5			0.550	20.700	10.559	-35.300	56.000	10.141	QP
6			0.550	6.862	-3.279	-39.138	46.000	10.141	AV
7			0.734	16.887	6.841	-39.113	56.000	10.046	QP
8			0.734	9.722	-0.323	-36.278	46.000	10.046	AV
9			1.234	16.581	6.680	-39.419	56.000	9.900	QP
10			1.234	11.034	1.134	-34.966	46.000	9.900	AV
11			13.930	18.770	8.704	-41.230	60.000	10.066	QP
12			13.930	8.481	-1.585	-41.519	50.000	10.066	AV

Note: Measure Level (dBμV) = Reading Level (dBμV) + Factor (dB)

Factor (dB) = Cable Loss (dB) + LISN Factor (dB).

Site: SR2	Time: 2015/08/17 - 14:04
Limit: FCC_Part15.207_CE_AC Power	Engineer: Line Chen
Probe: ENV216_101683_Filter On	Polarity: Neutral
EUT: Bluetooth Headset	Power: AC 120V/60Hz
Note: Mode1	

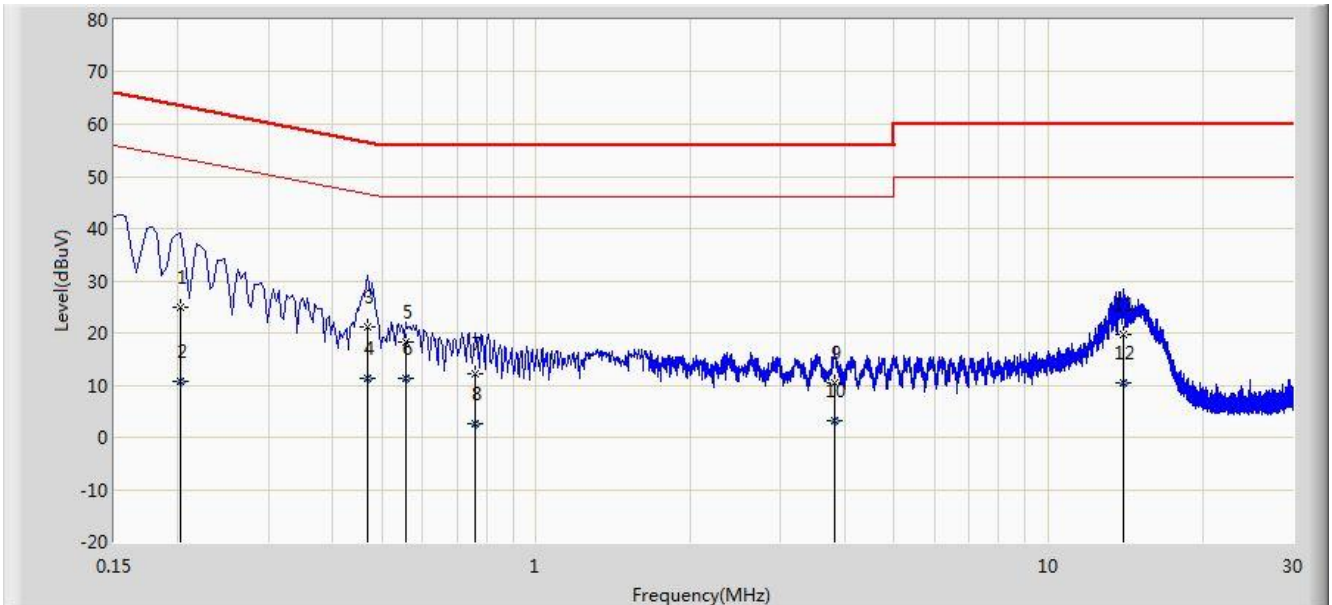

No	Flag	Mark	Frequency (MHz)	Measure Level (dBuV)	Reading Level (dBuV)	Over Limit (dB)	Limit (dBuV)	Factor (dB)	Type
1			0.202	25.034	15.026	-38.494	63.528	10.008	QP
2			0.202	10.649	0.641	-42.879	53.528	10.008	AV
3			0.470	21.228	11.063	-35.286	56.514	10.164	QP
4			0.470	11.187	1.022	-35.327	46.514	10.164	AV
5			0.558	18.307	8.153	-37.693	56.000	10.154	QP
6		*	0.558	11.406	1.252	-34.594	46.000	10.154	AV
7			0.762	12.288	2.247	-43.712	56.000	10.041	QP
8			0.762	2.518	-7.522	-43.482	46.000	10.041	AV
9			3.830	10.422	0.457	-45.578	56.000	9.966	QP
10			3.830	3.114	-6.852	-42.886	46.000	9.966	AV
11			13.986	19.576	9.463	-40.424	60.000	10.113	QP
12			13.986	10.438	0.325	-39.562	50.000	10.113	AV

Note: Measure Level (dBμV) = Reading Level (dBμV) + Factor (dB)

Factor (dB) = Cable Loss (dB) + LISN Factor (dB).

8. CONCLUSION

The data collected relate only the item(s) tested and show that the **Bluetooth Headset FCC ID: 2AE57CK-058** is in compliance with Part 15C of the FCC Rules.

The End