



Weather Station
MeteoTemp WTM Colour

Quickstart guide

Visit our website via the following QR Code or web link to find further information on this product or the available translations of these instructions.



www.bresser.de/P7007510



WARRANTY



www.bresser.de/warranty_terms

Contents

1	Imprint	22
3	About this Instruction Manual.....	23
4	General safety instructions	23
5	Parts overview and scope of delivery	27
6	Screen display	29
7	Setting up power supply.....	30
8	Automatic time setting.....	31
9	Receiving measurements automatically	32
10	Key functions.....	32
11	Technical data	34
12	EC Declaration of Conformity	35
13	Disposal	35
14	Warranty.....	36

1 Imprint

Bresser GmbH

Gutenbergstr. 2
46414 Rhede
Germany

<http://www.bresser.de>

If you wish to submit a warranty claim or service request, please refer to the “Warranty” and “Service” information in this document. Please be aware that any requests or submissions sent directly to the manufacturer cannot be processed.

Errors excepted. Subject to technical modifications.

© 2020 Bresser GmbH

All rights reserved.

Reproduction of this document, including extracts, in any form (photocopied, printed etc.) or the use and distribution of this document by electronic means (image file, website etc.) is not permitted without the prior written consent of the manufacturer.

The terms and brand names of the respective companies used in this document are protected by brand, patent or product law in Germany, the European Union and/or other countries.

2 Validity information

This documentation is valid for the products with the article numbers listed below:

7007510

Manual version: v062020a

Manual description:

Quickstart_7007510_MeteoTemp-WTM-Colour_US_en
_BRESSER_v062020a.pdf

With any service inquiries, please state these information.

3 About this Instruction Manual



NOTICE

This Quick Start guide is not intended to replace the more detailed user manual.

Please read the safety instructions and the operating instructions carefully before use.

4 General safety instructions



⚠ DANGER

Risk of electric shock

This device has electronic parts operated via a power source (power supply and/or batteries). Improper use of this product can cause an electric shock. An electric shock can cause serious or potentially fatal injuries. The following safety information must be observed at all times.

- Children must only use the device under adult supervision! Only use the device as described in the manual; otherwise, you run the risk of an electric shock.
 - Disconnect the device from the power supply by pulling the power plug when it is not used or in case of longer interruption of operation and before starting any work on maintenance and cleaning.
-

-
- Position your device so that it can be disconnected from the power supply at any time. The power socket should be installed near the device and should be easily accessible as the mains cable plug is used to disconnect the device from the power supply.
 - To disconnect the device from the power supply, always pull on the plug. Never pull on the cable.
 - Before starting up the device, check the device, the cables and the connections for signs of damage.
 - Never use a damaged device or a device with damaged live parts. Damaged parts must be immediately replaced by an authorised service company.
 - Only use the device in complete dry environment and do not touch it with wet or moist parts of your body.



DANGER



Risk of suffocation

Improper use of this product can result in suffocation. This is particularly dangerous for children. The following safety information must be observed at all times.

-
- Keep packaging materials (plastic bags, rubber bands etc.) away from children. They can cause suffocation.
 - This product contains small parts that could be swallowed by children. There is a risk of choking!



DANGER



Risk of explosion

Improper use of this product can cause an explosion. The following safety information must be observed at all times to prevent an explosion.

-
- Do not expose the device to high temperatures. Use only the supplied power supply or the recommended batteries. Do not short-circuit the device or batteries or throw them into a fire! Excessive heat or improper handling could trigger a short circuit, a fire, or an explosion.

NOTICE



Risk of damage to property

Improper handling can result in damage to the device and/or to the accessories. Always observe the following safety information when using the device.

-
- Never disassemble the device. In the event of a fault, please contact your specialist retailer. The specialist retailer will contact the service centre and send the device for repair if necessary.
 - Do not expose this device to higher temperatures and protect it from water and high humidity.
 - Do not immerse the unit in water!
 - Protect the device from severe shocks!
 - For this device only use accessories and spare parts that comply with the technical information.
 - Use only the recommended batteries. Always replace weak or empty batteries with a new, complete set of batteries at full capacity. Do not use batteries from different brands or with different capacities. Remove the batteries from the unit if it has not been used for a long time.
 - Never use rechargeable batteries.



NOTICE

Risk of voltage damage!

The manufacturer is not liable for voltage damage due to improperly inserted batteries or through the use of an improper power adapter!

5 Parts overview and scope of delivery

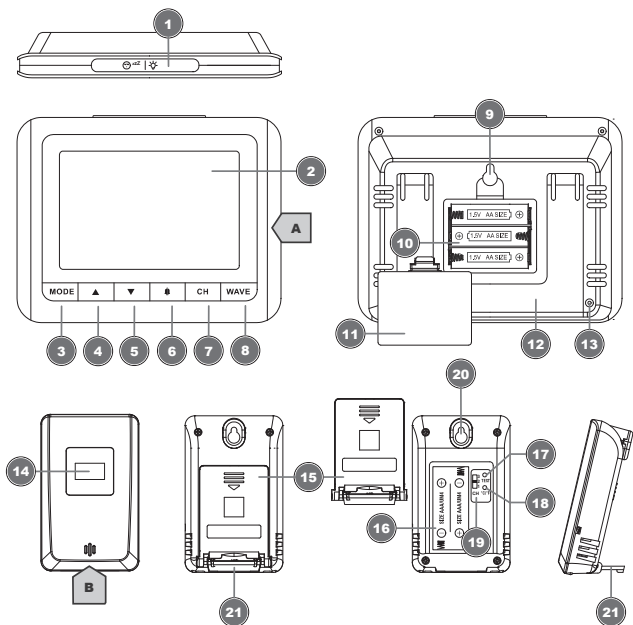

Illustration 1: Parts overview for base station (top) and remote sensor (bottom)

1	SNOOZE/LIGHT button (snooze function and temporary background lighting)	2	Display
3	MODE button (time mode selection and settings)	4	UP button (Value setting upwards)
5	DOWN button (Value setting downwards, temperature unit selection (°C/°F), pressure value selection)	6	ALARM button (Alarm setting)
7	CH button (channel selection)	8	WAVE button (Initiate data reception from the wireless sensor)
9	Mounting hole (Base station)	10	Battery compartment (Base station)
11	Battery compartment cover (Base station)	12	Stand, fold-out
13	DC connection socket for coaxial/barrel connector	14	Display (Remote sensor)
15	Battery compartment cover (Remote sensor)	16	Battery compartment (Remote sensor)
17	TEST button (Transmits the current measured values)	18	°C/°F button (temperature format setting)
19	Channel selector switch	20	Mount hole (Remote sensor)
21	Stand, fold-out	22	DC power adapter with US mains plug.
23	DC coaxial/barrel connector		

Scope of delivery

Base station (A), remote sensor (B), power adapter (C)
 Recommended batteries (not included)

3 pcs. Mignon batteries (1.5V, AA type), 2 pcs. Micro batteries (1.5V, AAA type)

6 Screen display

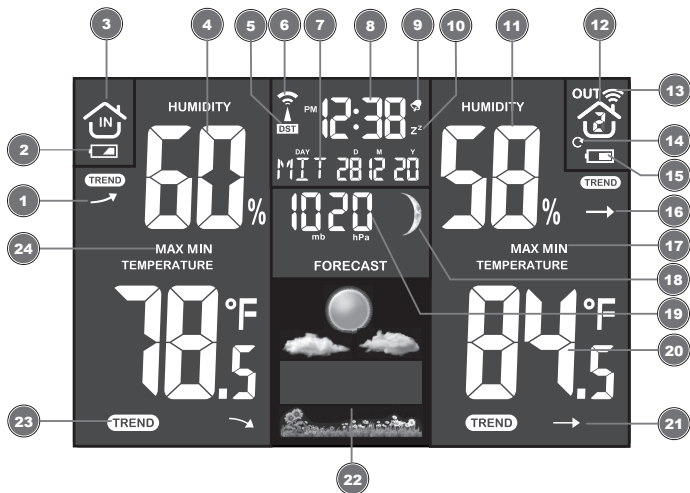

Illustration 2: Screen display for the base station

1	Humidity trend (indoor) (rising, steady or falling)	2	Battery level indicator (base station)
3	Symbol indoor area	4	Indoor humidity value
5	Daylight saving time (DST)	6	Symbol for radio signal
7	Weekday, Day (D), Month (M), Year (Y)	8	Current time
9	Alarm symbol (Alarm enabled)	10	Snooze function enabled

11	Humidity value (outdoor)	12	Symbol outdoor area with channel display
13	Remote sensor signal strength	14	Symbol for channel rotation
15	Battery level indicator (Remote sensor)	16	Humidity trend (outdoor) (rising, steady or falling)
17	Symbol for highest (MAX) or lowest (MIN) value (outdoor)	18	Moon phase
19	Air pressure (mb/hPa or inHg)	20	Temperature value (outdoor)
21	Temperature trend (outdoor) (rising, steady or falling)	22	Graphical weather forecast display
23	Temperature trend (indoor) (rising, steady or falling)	24	Symbol for highest (MAX) or lowest (MIN) value (indoor)

7 Setting up power supply

Base device

1. Insert the DC connector into the connection socket of the base station.
2. Insert the mains plug into the power outlet.
3. The device is energized directly.
4. Wait until the indoor temperature is displayed on the base station.

NOTICE! For permanent operation, mains power supply is recommended. Alternatively a power supply with batteries is also possible, to keep the time setting in case of power failure. Proceed as follows:

5. Remove the battery compartment cover.
6. Insert the batteries into the battery compartment. Ensure that the battery polarity (+/-) is correct.

-
7. Replace the battery compartment cover.
 8. Wait until the indoor temperature is displayed on the base station.

NOTICE! When switching from mains power supply to battery power supply or vice versa, the power supply is being disabled for a short moment for technical reasons. Exception: permanent battery operation.

Remote sensor

9. Remove the battery compartment cover.
10. Insert the batteries into the battery compartment. Ensure that the battery polarity (+/-) is correct.
11. Set the channel selector switch to the desired channel.

NOTICE! This weather station can be operated with one or more remote sensors. Each remote sensor being connected must be operated on a different channel. If only one remote sensor is connected, it should be operated on channel 1.

12. Replace the battery compartment cover.

8 Receiving measurements automatically



Once the power supply is enabled, the base station will display the measurement readings. Readings from the remote sensor will be displayed within 3 minutes after powering it on.

If no signal is received, go ahead with the following steps:

Press and hold the CH button for 3 seconds to re-initialize RC signal receiving.

Read the detailed manual for more information about readings (see download information on page 2).

9 Key functions

Operation	Buttons	 zzz 	MODE
Standard mode	press	Light on for 5 seconds/ snooze	Switch time mode 12/24h
	hold	Turn off alarm	Enter time setting
Time set	press	-----	Select/Confirm settings

Operation	Buttons	▼	▲
Standard mode	press	Temperature format selection (°C/°F)	Check max/min record
	hold	Switch pressure mode (hpa/mb-inHg)	Clear max/min record
Time set	press	Backward	Forward
	hold	fast backward	fast forward
Alarm set	press	Backward	Forward
	hold	Fast backward	Fast forward

Operation	Buttons		CH
Standard mode	press	Check alarm time; turn on/off alarm	Switch channel (CH1/CH2/CH3) and Channel cycle (10 sec. interval)
	hold	Enter alarm settings	Initiate new reception of sensor data
Alarm set	press	Confirm settings	-----

10 Technical data

Base station

Batteries	3x AA, 1.5 V
Maximum number of sensors	3
Temperature unit	°C / °F
Temperature measuring range	-0°C – 50°C
Humidity measuring range	20% to 90% RH
Humidity resolution	1% HR
Barometer measuring range	800 hPa to 1100 hPa (23.62 inHg to 32.49 inHg)
Time display	HH:MM
Time format	12 or 24 hours
Dimensions	165 x 130 x 30 mm (W x H x D)
Weight	268 g (without batteries) 336 g (with batteries)

Remote sensor

Batteries	2x AAA, 1.5V
Transmission frequency	433 MHz
Transmission measuring range	30 m
Maximum radio-frequency power	under 10mW
Temperature unit	°C / °F

Temperature measuring range	-40°C – 70°C
Humidity measuring range	20% to 90% RH
Humidity resolution	1% HR
Dimensions	60 x 95 x 25 mm (W x H x D)
Weight	50 g (without batteries) 73g (with batteries)

11 EC Declaration of Conformity

Hereby, Bresser GmbH declares that the equipment type with part number: 7007510 is in compliance with Directive: 2014/30/EU. The full text of the EU declaration of conformity is available at the following internet address: <http://www.bresser.de> • info@bresser.de

12 FCC compliance statement

This device complies with Part 15 of the FCC Rules. Operation is subject to the following two conditions: (1) this device may not cause harmful interference, and (2) this device must accept any interference received, including interference that may cause undesired operation.

Changes or modifications not expressly approved by the party responsible for compliance could void the user's authority to operate the equipment.

This equipment has been tested and found to comply with the limits for a Class B digital device, pursuant to Part 15 of the FCC Rules. These limits are designed to provide reasonable protection against harmful interference in a residential installation. This equipment generates, uses and can radiate radio frequency energy and, if not installed and used in

accordance with the instructions, may cause harmful interference to radio communications. However, there is no guarantee that interference will not occur in a particular installation.

If this equipment does cause harmful interference to radio or television reception, which can be determined by turning the equipment off and on, the user is encouraged to try to correct the interference by one or more of the following measures:

- Reorient or relocate the receiving antenna.
- Increase the separation between the equipment and receiver.
- Connect the equipment into an outlet on a circuit different from that to which the receiver is connected.
- Consult the dealer or an experienced radio/TV technician for help.

13 Disposal



Sort packaging into different materials for disposal. Contact the local waste disposal service provider or environmental agency for information about appropriate waste management.

Do not dispose of electrical devices with the household waste.

In accordance with European Directive 2002/96/EC regarding waste electrical and electronic equipment and its incorporation into national law, used electrical devices must be collected separately and recycled in an environmentally friendly manner.

Do not dispose of batteries and rechargeable batteries with the household waste. You are legally required to return used batteries and rechargeable batteries. After

they are used, the batteries can be returned free of charge to our point of sale or to a nearby location (for example, retailers or municipal collecting points).

Batteries and rechargeable batteries are marked with a symbol of a crossed-out dustbin and the chemical symbol of the pollutant. “Cd” stands for Cadmium, “Hg” stands for mercury and “Pb” stands for lead.

14 Warranty

The regular guarantee period is 2 years and begins on the day of purchase. To benefit from an extended voluntary guarantee period as stated on the gift box, registration on our website is required.

You can consult the full guarantee terms as well as information on extending the guarantee period and details of our services at [**www.bresser.de/warranty_terms**](http://www.bresser.de/warranty_terms).

