



EMC TEST REPORT

Applicant Alcatel-Lucent Shanghai Bell CO. Ltd.
FCC ID 2ADZRHA030WB
Product 7368 Intelligent Services Access Manager CPE
Brand NOKIA
Model HA-030W-B
Report No. RBA1712-0148EMC02R1
Issue Date January 25, 2018

TA Technology (Shanghai) Co., Ltd. tested the above equipment in accordance with the requirements in **FCC Code CFR47 Part15B (2017)/ ANSI C63.4 (2014)**. The test results show that the equipment tested is capable of demonstrating compliance with the requirements as documented in this report.

Wei Liu

Guangchang Fan

Performed by: Wei Liu/ Manager

Approved by: Guangchang Fan/ Director

TA Technology (Shanghai) Co., Ltd.

No.145, Jintang Rd, Tangzhen Industry Park, Pudong Shanghai, China

TEL: +86-021-50791141/2/3

FAX: +86-021-50791141/2/3-8000



Table of Contents

1	Test Laboratory.....	4
1.1	Notes of the Test Report.....	4
1.2	Test facility.....	4
1.3	Testing Location.....	5
2	General Description of Equipment under Test.....	6
2.1	Client Information.....	6
2.2	General information.....	6
2.3	Applied Standards.....	7
2.4	Test Mode.....	9
3	Test Case Results.....	10
3.1	Radiated Emission.....	10
3.2	Conducted Emission.....	16
4	Main Test Instrument.....	19
	ANNEX A: The EUT Appearance and Test Configuration.....	20
	A.1 EUT Appearance.....	20
	A.2 Test Setup.....	22
	A.3 Auxiliary test equipment.....	24



Summary of measurement results

Number	Test Case	Clause in FCC Rules	Conclusion
1	Radiated Emission	15.109, ANSI C63.4-2014	PASS
2	Conducted Emission	15.107, ANSI C63.4-2014	PASS
Test Date: December 18, 2017 ~ January 16, 2018			

1 Test Laboratory

1.1 Notes of the Test Report

This report shall not be reproduced in full or partial, without the written approval of **TA technology (shanghai) co., Ltd.** The results documented in this report apply only to the tested sample, under the conditions and modes of operation as described herein .Measurement Uncertainties were not taken into account and are published for informational purposes only. This report is written to support regulatory compliance of the applicable standards stated above.

1.2 Test facility

CNAS (accreditation number: L2264)

TA Technology (Shanghai) Co., Ltd. has obtained the accreditation of China National Accreditation Service for Conformity Assessment (CNAS).

FCC (Designation number: CN1179, Test Firm Registration Number: 446626)

TA Technology (Shanghai) Co., Ltd. has been listed on the US Federal Communications Commission list of test facilities recognized to perform electromagnetic emissions measurements.

IC (recognition number is 8510A)

TA Technology (Shanghai) Co., Ltd. has been listed by industry Canada to perform electromagnetic emission measurement.

VCCI (recognition number is C-4595, T-2154, R-4113, G-10766)

TA Technology (Shanghai) Co., Ltd. has been listed by industry Japan to perform electromagnetic emission measurement.

A2LA (Certificate Number: 3857.01)

TA Technology (Shanghai) Co., Ltd. has been listed by American Association for Laboratory Accreditation to perform electromagnetic emission measurement.



1.3 Testing Location

Company: TA Technology (Shanghai) Co., Ltd.
Address: No.145, Jintang Rd, Tangzhen Industry Park, Pudong Shanghai, China
City: Shanghai
Post code: 201201
Country: P. R. China
Contact: Xu Kai
Telephone: +86-021-50791141/2/3
Fax: +86-021-50791141/2/3-8000
Website: <http://www.ta-shanghai.com>
E-mail: xukai@ta-shanghai.com

2 General Description of Equipment under Test

2.1 Client Information

Applicant	Alcatel-Lucent Shanghai Bell CO. Ltd.
Applicant address	388-389#, Ningqiao Road, Pudong Jinqiao, Shanghai, P.R. China
Manufacturer	TAICANG T&W ELECTRONICS CO.,LTD
Manufacturer address	89# Jiang Nan RD, Lu Du, Taicang, Jiangsu, China

2.2 General information

EUT Description	
Device Type	Portable Device
Product Name	7368 Intelligent Services Access Manager CPE
Model Number	HA-030W-B
SN	/
HW Version	PEM2
SW Version	Null
Antenna Type	Internal Antenna
Test Mode	Transfer Data Mode
EUT Accessory	
Adapter 1	Manufacturer: Dongguan Shilong Fuhua Electronic Co., Ltd Model: UES36WA-120300SPAU
Adapter 2	Manufacturer:RUIDE Model: RD1202000-C55-80MG
Auxiliary test equipment	
PC	PC Manufacturer: Dell Model: E5450 (SN : P48G001)
Remark: The information of the EUT is declared by the manufacturer.	

**EUT Configuration**

No.	Name	Model/Code No.	Edition	Serial No. or Quantity
1	EMA-HA-030W-B	3FE47429AA	PEM2	PEM 1
2	Power adapter	UES36WA-120300SPAU	A/0	PEM 1
3	Power adapter	RD1202000-C55-80MG	A/0	PEM 1

ONT Mnemonic	Kit Code	EMA Code	Part Description
HA-030W-B	3FE47357AA	3FE47429AA	Wi-Fi Access Point and range extender, 3xGE UNI, 3x3 11n+4x4 11ac, US plug

Auxiliary Equipment

No.	Name	Brand name	Model	ASB code	Valid Until
1	SmartBits 600B	Sprint	DE7853	-	No Cal. Required
2	PC	HP	N.A	-	No Cal. Required
3	PC	DELL	N.A	-	No Cal. Required
4	PC	Thinkpad	N.A	-	No Cal. Required

Ports

No.	Port name	Number	Shielded or unshielded	Cable type (optic, twisted pair, etc.)	Max. Cable length
1	Power	1	unshielded	-	-
2	GE	4	unshielded	-	-



2.3 Applied Standards

According to the specifications of the manufacturer, it must comply with the requirements of the following standards:

Test standards

FCC Code CFR47 Part15B (2017)

ANSI C63.4 (2014)

2.4 Test configuration

The HA-030W-B is a AP which has 3 GE LAN ports, and 1 GE WAN port.

The basic functional test in normal room conditions consists of the traffic test and WIFI throughput test. HA-030W-B runs 2traffics on each line with SMB600B, the each upstream of 2 GE is 1Gbps, and downstream is 1Gbps. Frame loss ratio less than 10e-7. The WIFI keep connecting.

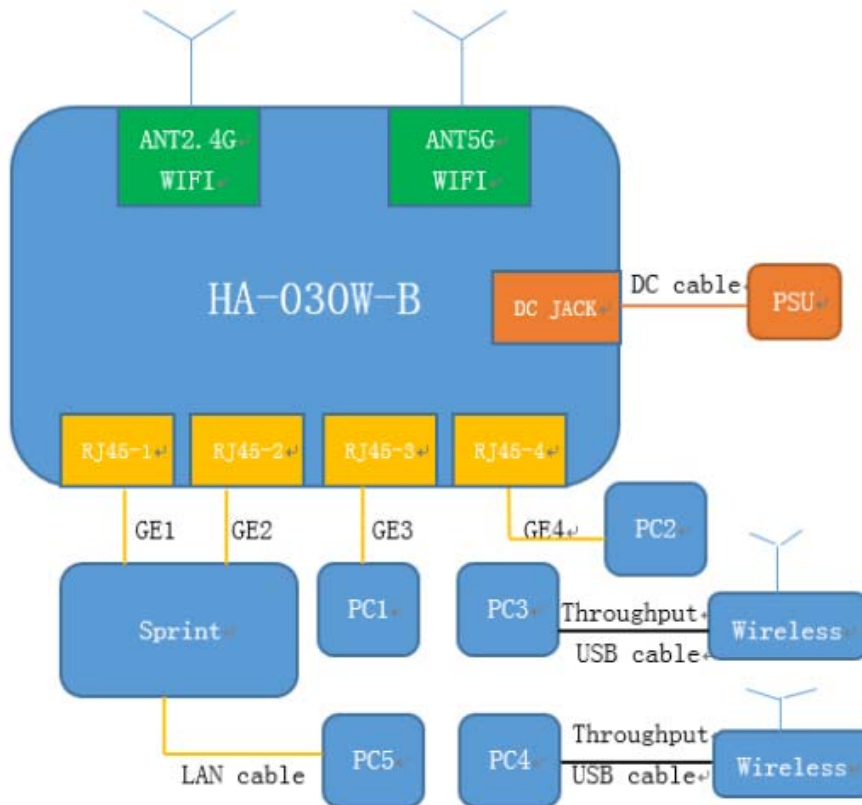

Test configuration

3 Test Case Results

3.1 Radiated Emission

Ambient condition

Temperature	Relative humidity	Pressure
24°C~26°C	45%~50%	102.5kPa

Methods of Measurement

The EUT is placed on a non-metallic table 0.8m above the horizontal metal reference ground plane. The distance between EUT and receive antenna should be 3 meters. During the test, the EUT was operating in its typical mode. The test method is according to ANSI C63.4-2014. Sweep the whole frequency band through the range from 30MHz to the 5th harmonic of the carrier. During the test, the height of receive antenna shall be moved from 1 to 4 meters, and the antenna shall be performed under horizontal and vertical polarization. The turn table shall be rotated from 0 to 360 degrees for detecting the maximum of radiated signal level.

The data of cable loss and antenna factor has been calibrated in full testing frequency range before the testing. During the test, the EUT is worked at maximum output power.

Set the spectrum analyzer in the following:

Below 1GHz:

RBW=100 kHz / VBW=300 kHz / Sweep=AUTO

Above 1GHz:

(a) PEAK: RBW=1MHz / VBW=3MHz / Sweep=AUTO

(b) AVERAGE: RBW=1MHz / VBW=3MHz / Sweep=AUTO

The radiated emission was measured in the following position: EUT stand-up position (Z axis), lie-down position (X, Y axis). The worst emission was found in stand-up position (Z axis) and the worst case was recorded.

During the test, reference test configuration, EUT is connected to laptop via a cable in the case of Transfer Data mode.

Test Setup

Below 1GHz

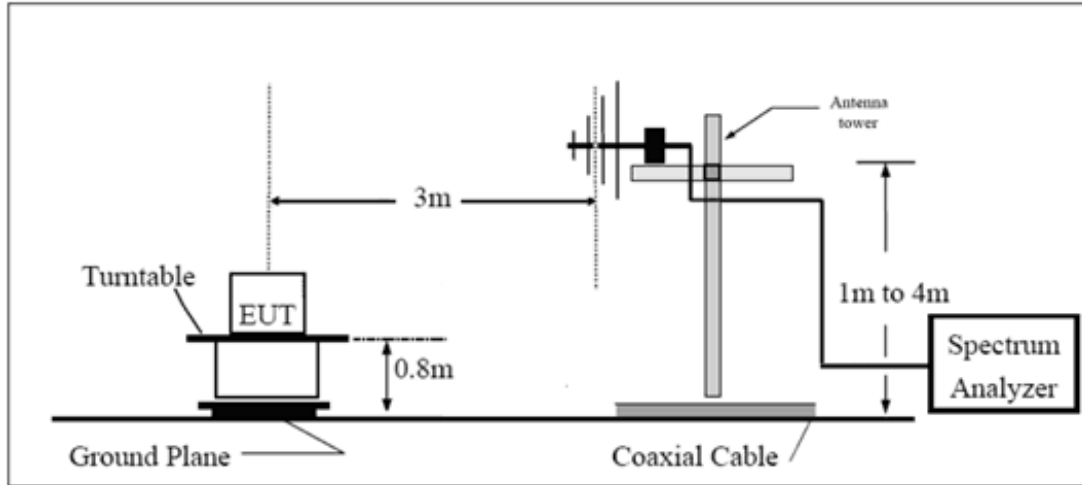

Above 1GHz

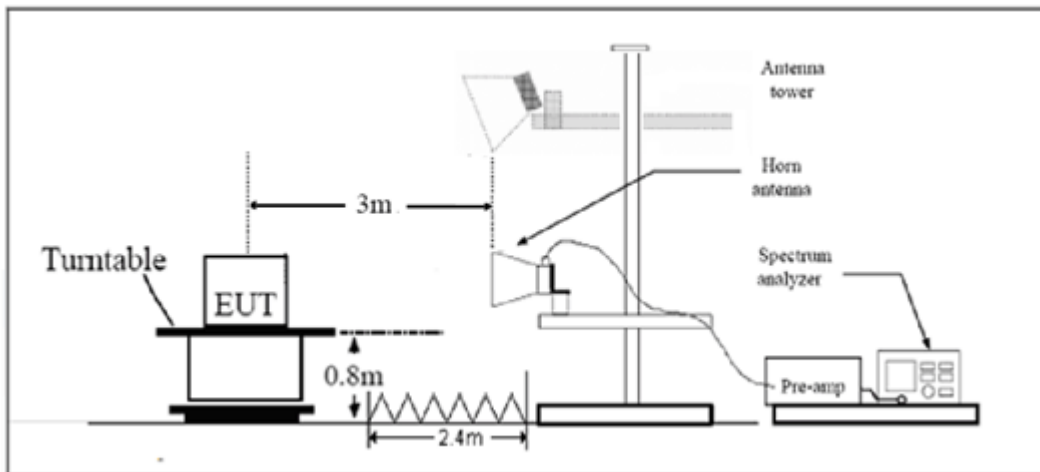

Note: Area side:2.4mX3.6m

Antenna Tower meets ANSI C63.4 requirements for measurements above 1 GHz by keeping the antenna aimed at the EUT during the antenna's ascent/ descent along the antenna mast.

**Limits**

Frequency (MHz)	Field Strength (dB μ V/m)	Detector
30 -88	40.0	Quasi-peak
88-216	43.5	Quasi-peak
216 – 960	46.0	Quasi-peak
960-1000	54.0	Quasi-peak
1000-5 th harmonic of the highest frequency or 40GHz, which is lower	54 74	Average Peak

Measurement Uncertainty

The assessed measurement uncertainty to ensure 95% confidence level for the normal distribution is with the coverage factor $k = 1.96$. $U = 3.704$ dB.

Test Results

The following graphs display the maximum values of horizontal and vertical by software. For above 1GHz, Blue trace uses the peak detection, Green trace uses the average detection. There is more than one Adapter, each one should be applied throughout the compliance test respectively, and however, only the worst case (Adapter 1) will be recorded in this report.

Adapter 1

RE 30M-1GHz QP

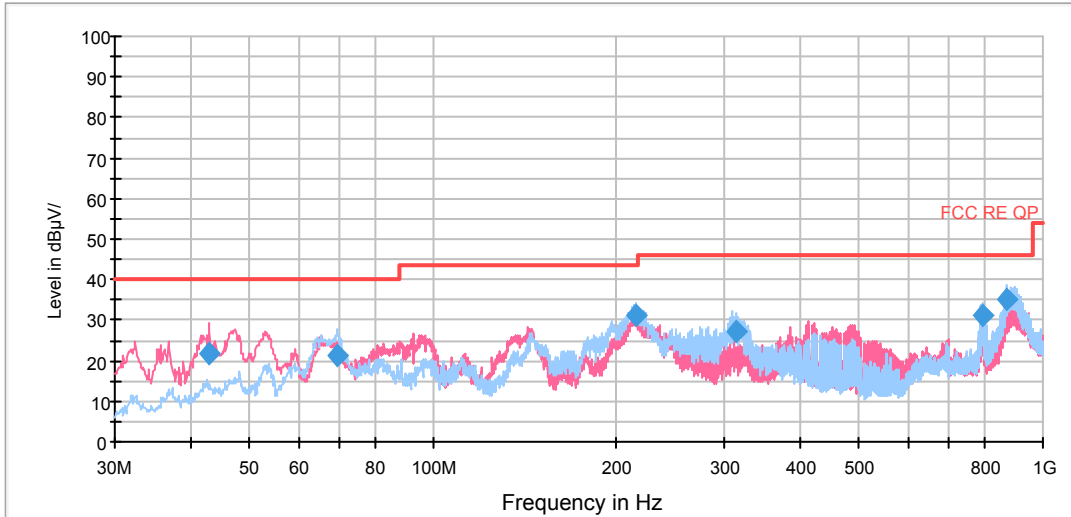

Radiated Emission from 30MHz to 1GHz

Frequency (MHz)	Quasi-Peak (dBuV/m)	Reading value (dBuV/m)	Height (cm)	Polarization	Azimuth (deg)	Correct Factor (dB)	Margin (dB)	Limit (dBuV/m)
42.959631	21.7	39.4	100.0	V	109.0	-17.7	18.3	40.0
69.593681	21.3	47.7	125.0	H	195.0	-26.4	18.7	40.0
214.368000	31.0	56.7	125.0	H	56.0	-25.7	12.5	43.5
313.543750	27.2	49.5	100.0	H	127.0	-22.3	18.8	46.0
797.770000	31.1	47.7	100.0	H	324.0	-16.6	14.9	46.0
875.009250	35.2	49.3	100.0	H	260.0	-14.1	10.8	46.0

- Remark:**
1. Quasi-Peak = Reading value + Correction factor
 2. Correction Factor = Antenna factor+ Insertion loss(cable loss+amplifier gain)
 3. Margin = Limit – Quasi-Peak

RE 1G-3GHz PK+AV

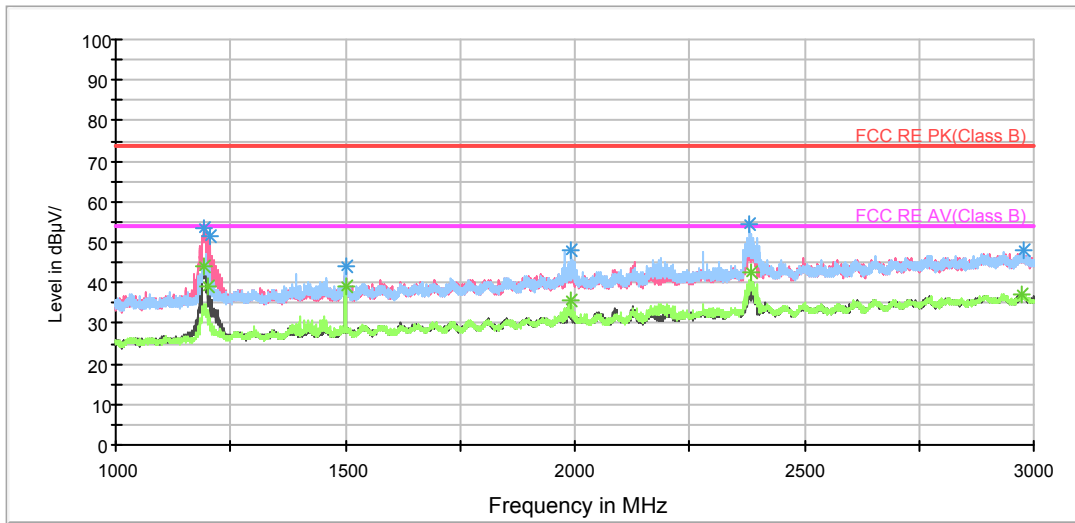

Radiated Emission from 1GHz to 3GHz

Frequency (MHz)	Peak (dBuV/m)	Reading value (dBuV/m)	Height (cm)	Polarization	Azimuth (deg)	Correct Factor (dB)	Margin (dB)	Limit (dBuV/m)
1194.250000	53.6	61.8	100.0	V	0.0	-8.2	20.4	74
1203.250000	51.4	59.6	100.0	V	0.0	-8.2	22.6	74
1500.250000	44.2	50.9	100.0	H	81.0	-6.7	29.8	74
1993.250000	47.9	51.2	100.0	H	0.0	-3.3	26.1	74
2381.750000	54.5	56.0	100.0	H	280.0	-1.5	19.5	74
2980.250000	48.0	45.8	100.0	H	0.0	2.2	26.0	74

Frequency (MHz)	Average (dBuV/m)	Reading value (dBuV/m)	Height (cm)	Polarization	Azimuth (deg)	Correct Factor (dB)	Margin (dB)	Limit (dBuV/m)
1192.250000	44.2	52.4	100.0	V	0.0	-8.2	9.8	54
1201.500000	39.0	47.2	100.0	V	0.0	-8.2	15.0	54
1500.000000	38.9	45.6	100.0	H	90.0	-6.7	15.1	54
1993.250000	35.6	38.9	100.0	H	0.0	-3.3	18.4	54
2383.500000	42.4	43.9	100.0	H	280.0	-1.5	11.6	54
2972.000000	37.2	35.0	100.0	V	237.0	2.2	16.8	54

RE 3-18GHz PK+AV

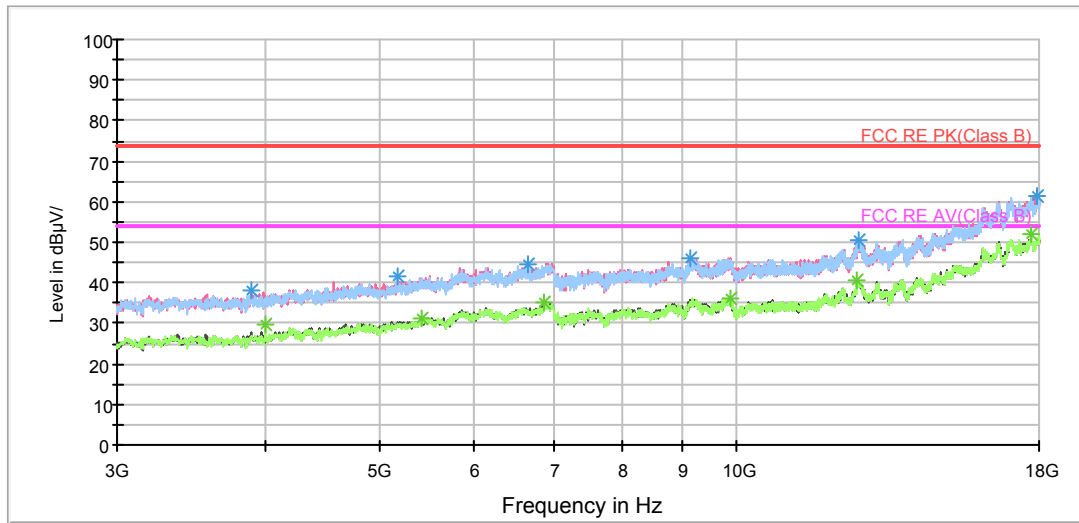

Radiated Emission from 3GHz to 18GHz

Frequency (MHz)	Peak (dBuV/m)	Reading value (dBuV/m)	Height (cm)	Polarization	Azimuth (deg)	Correct Factor (dB)	Margin (dB)	Limit (dBuV/m)
3890.625000	38.1	39.4	100.0	V	354.0	-1.3	35.9	74
5165.625000	41.4	39.4	100.0	H	4.0	2.0	32.6	74
6663.750000	44.8	39.3	100.0	V	0.0	5.5	29.2	74
9151.875000	46.3	36.1	100.0	V	354.0	10.2	27.7	74
12658.125000	50.7	36.8	100.0	H	134.0	13.9	23.3	74
17911.875000	61.6	36.1	100.0	V	290.0	25.5	12.4	74

Frequency (MHz)	Average (dBuV/m)	Reading value (dBuV/m)	Height (cm)	Polarization	Azimuth (deg)	Correct Factor (dB)	Margin (dB)	Limit (dBuV/m)
3999.375000	29.9	31.0	100.0	H	358.0	-1.1	24.1	54
5424.375000	31.2	28.5	100.0	H	69.0	2.7	22.8	54
6890.625000	35.2	29.1	100.0	H	4.0	6.1	18.8	54
9862.500000	36.1	25.7	100.0	H	166.0	10.4	17.9	54
12641.250000	40.5	26.0	100.0	V	322.0	14.5	13.5	54
17700.000000	51.7	27.0	100.0	V	0.0	24.7	2.3	54

3.2 Conducted Emission

Ambient condition

Temperature	Relative humidity	Pressure
24°C ~26°C	50%~55%	102.5kPa

Methods of Measurement

The EUT is placed on a non-metallic table of 80cm height above the horizontal metal reference ground plane. During the test, the EUT was operating in its typical mode. The test method is according to ANSI C63.4-2014. Connect the AC power line of the EUT to the L.I.S.N. Use EMI receiver to detect the average and Quasi-peak value. RBW is set to 9 kHz, VBW is set to 30kHz. The measurement result should include both L line and N line.

During the test, reference test configuration, EUT is connected to laptop via a cable in the case of Transfer Data mode.

Test Setup

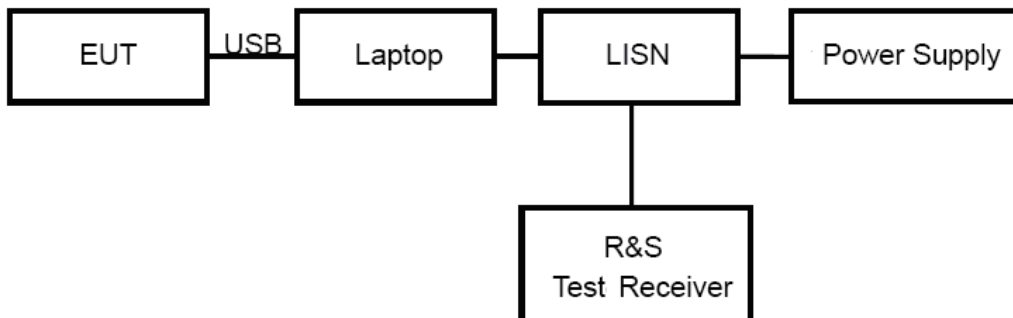

Note: Power Supply is AC Power source and it is used to change the voltage 120V/60Hz.

Limits

Frequency (MHz)	Conducted Limits(dBμV)	
	Quasi-peak	Average
0.15 - 0.5	66 to 56 *	56 to 46 *
0.5 - 5	56	46
5 - 30	60	50

*: Decreases with the logarithm of the frequency.

Measurement Uncertainty

The assessed measurement uncertainty to ensure 95% confidence level for the normal distribution is with the coverage factor $k = 1.96$. $U = 2.57$ dB.

Test Results

Following plots, Blue trace uses the peak detection; Green trace uses the average detection.

Adapter 1

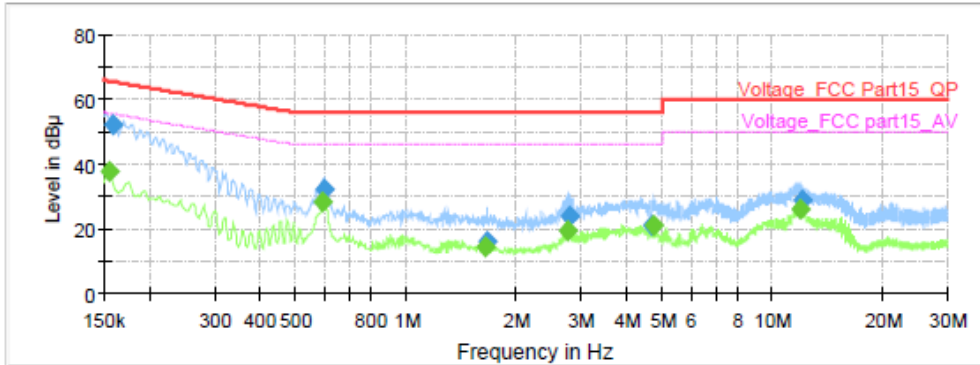

Frequency (MHz)	QuasiPeak (dB μ V)	Average (dB μ V)	Limit (dB μ V)	Margin (dB)	Meas. Time (ms)	Bandwidth (kHz)	Line	Filter	Corr. (dB)
0.154500	---	37.94	55.75	17.82	1000.0	9.000	L1	ON	19.6
0.159000	52.16	---	65.52	13.36	1000.0	9.000	L1	ON	19.6
0.591000	---	28.32	46.00	17.68	1000.0	9.000	L1	ON	19.6
0.595500	32.41	---	56.00	23.59	1000.0	9.000	L1	ON	19.6
1.641750	---	14.70	46.00	31.30	1000.0	9.000	L1	ON	19.6
1.666500	15.93	---	56.00	40.07	1000.0	9.000	L1	ON	19.6
2.766750	---	19.53	46.00	26.47	1000.0	9.000	L1	ON	19.6
2.784750	23.85	---	56.00	32.15	1000.0	9.000	L1	ON	19.6
4.697250	21.17	---	56.00	34.83	1000.0	9.000	L1	ON	19.7
4.751250	---	21.16	46.00	24.84	1000.0	9.000	L1	ON	19.7
11.917500	---	26.15	50.00	23.85	1000.0	9.000	L1	ON	19.9
11.998500	28.79	---	60.00	31.21	1000.0	9.000	L1	ON	19.9

L line

Conducted Emission from 150 KHz to 30 MHz

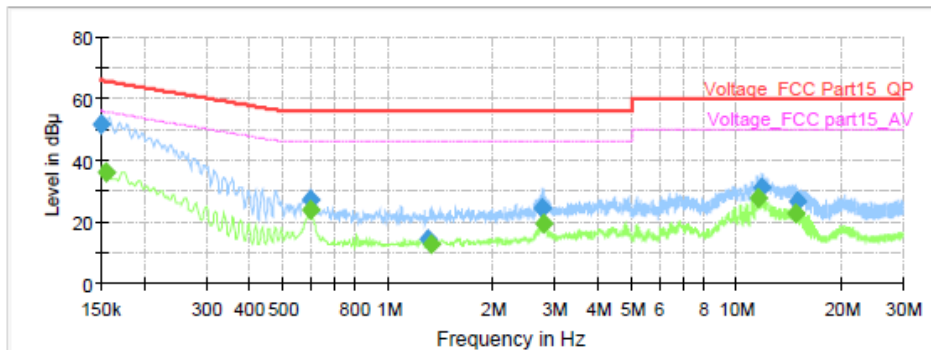

Frequency (MHz)	QuasiPeak (dB μ V)	Average (dB μ V)	Limit (dB μ V)	Margin (dB)	Meas. Time (ms)	Bandwidth (kHz)	Line	Filter	Corr. (dB)
0.150000	51.92	---	66.00	14.08	1000.0	9.000	N	ON	19.7
0.154500	---	36.13	55.75	19.62	1000.0	9.000	N	ON	19.7
0.595500	---	23.79	46.00	22.21	1000.0	9.000	N	ON	19.6
0.600000	27.10	---	56.00	28.90	1000.0	9.000	N	ON	19.6
1.306500	14.24	---	56.00	41.76	1000.0	9.000	N	ON	19.6
1.329000	---	12.99	46.00	33.01	1000.0	9.000	N	ON	19.6
2.769000	24.52	---	56.00	31.48	1000.0	9.000	N	ON	19.6
2.798250	---	19.48	46.00	26.52	1000.0	9.000	N	ON	19.6
11.539500	---	27.95	50.00	22.05	1000.0	9.000	N	ON	19.9
11.807250	30.86	---	60.00	29.14	1000.0	9.000	N	ON	19.9
14.851500	---	22.77	50.00	27.23	1000.0	9.000	N	ON	19.9
14.885250	26.58	---	60.00	33.42	1000.0	9.000	N	ON	19.9

N line

Conducted Emission from 150 KHz to 30 MHz

Adapter 2

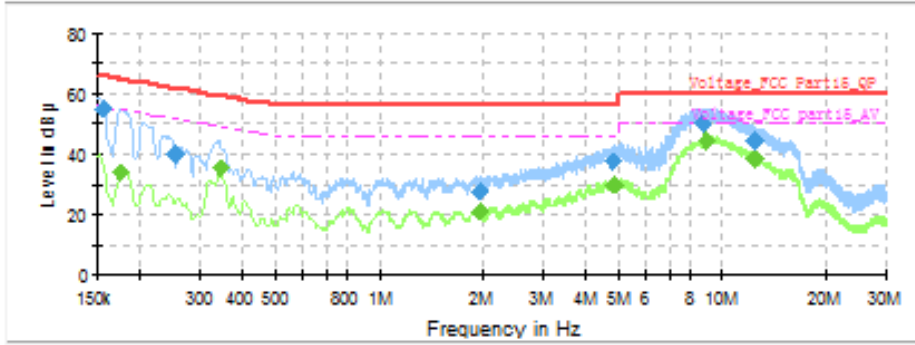

Frequency (MHz)	QuasiPeak (dB µV)	Average (dB µV)	Limit (dB µV)	Margin (dB)	Meas. Time (ms)	Bandwidth (kHz)	Line	Filter	Corr. (dB)
0.156750	54.96	---	65.63	10.68	1000.0	9.000	L1	ON	19.6
0.174750	---	33.68	54.73	21.05	1000.0	9.000	L1	ON	19.6
0.253500	40.25	---	61.64	21.39	1000.0	9.000	L1	ON	19.7
0.345750	---	35.76	49.06	13.31	1000.0	9.000	L1	ON	19.6
1.963500	---	21.23	46.00	24.77	1000.0	9.000	L1	ON	19.6
1.965750	27.63	---	56.00	28.37	1000.0	9.000	L1	ON	19.6
4.807500	37.51	---	56.00	18.45	1000.0	9.000	L1	ON	19.7
4.870500	---	30.27	46.00	15.73	1000.0	9.000	L1	ON	19.7
8.828250	50.07	---	60.00	9.93	1000.0	9.000	L1	ON	19.9
8.974500	---	44.58	50.00	5.42	1000.0	9.000	L1	ON	19.9
12.421500	44.55	---	60.00	15.45	1000.0	9.000	L1	ON	19.9
12.527250	---	38.50	50.00	11.50	1000.0	9.000	L1	ON	19.9

L line

Conducted Emission from 150 KHz to 30 MHz

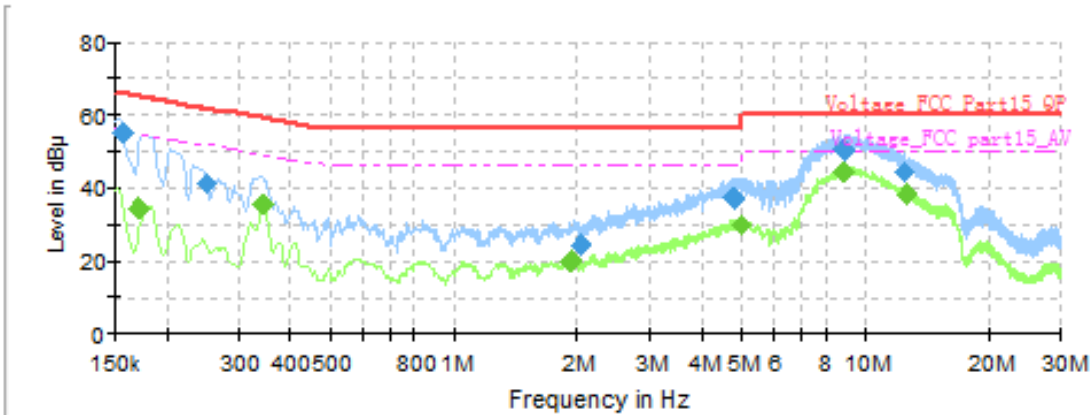

Frequency (MHz)	QuasiPeak (dB µV)	Average (dB µV)	Limit (dB µV)	Margin (dB)	Meas. Time (ms)	Bandwidth (kHz)	Line	Filter	Corr. (dB)
0.156750	55.04	---	65.63	10.60	1000.0	9.000	N	ON	19.7
0.172500	---	34.40	54.84	20.44	1000.0	9.000	N	ON	19.7
0.251250	40.85	---	61.72	20.87	1000.0	9.000	N	ON	19.7
0.345750	---	35.33	49.06	13.73	1000.0	9.000	N	ON	19.6
1.934250	---	19.89	46.00	26.11	1000.0	9.000	N	ON	19.6
2.049000	24.32	---	56.00	31.68	1000.0	9.000	N	ON	19.6
4.800750	37.04	---	56.00	18.96	1000.0	9.000	N	ON	19.7
5.032500	---	30.24	50.00	19.76	1000.0	9.000	N	ON	19.7
8.871000	50.45	---	60.00	9.55	1000.0	9.000	N	ON	19.9
8.922750	---	44.68	50.00	5.32	1000.0	9.000	N	ON	19.9
12.477750	44.49	---	60.00	15.51	1000.0	9.000	N	ON	19.9
12.592500	---	38.41	50.00	11.59	1000.0	9.000	N	ON	19.9

N line

Conducted Emission from 150 KHz to 30 MHz

4 Main Test Instrument

Name	Manufacturer	Type	Serial Number	Last Cal.	Cal. Due Date
Signal Analyzer	R&S	FSV30	100815	2017-12-17	2018-12-16
EMI Test Receiver	R&S	ESCI	100948	2017-05-20	2018-05-19
Loop Antenna	SCHWARZBECK	FMZB1519	1519-047	2017-02-18	2019-02-17
Trilog Antenna	SCHWARZBECK	VULB 9163	9163-201	2017-11-18	2020-11-17
Horn Antenna	R&S	HF907	100126	2014-12-06	2019-12-05
Horn Antenna	ETS-Lindgren	3160-09	00102643	2015-01-30	2018-01-29
EMI Test Receiver	R&S	ESR	101667	2017-09-06	2018-09-05
LISN	R&S	ENV216	101171	2016-12-16	2019-12-15
Bore Sight Antenna mast	ETS	2171B	00058752	NA	NA
Test software	EMC32	R&S	V9.26.0	NA	NA

ANNEX A: The EUT Appearance and Test Configuration

A.1 EUT Appearance



Front Side



Back Side

a: EUT



Adapter 1



Adapter 2

b: Adapter

Picture 1 EUT

A.2 Test Setup



a: Below 1GHz



b: Above 1GHz

Picture 2 Radiated Emission Test Setup



Picture 3 Conducted Emission Test Setup

A.3 Auxiliary test equipment

