

RE 1G-3GHz PK+AV

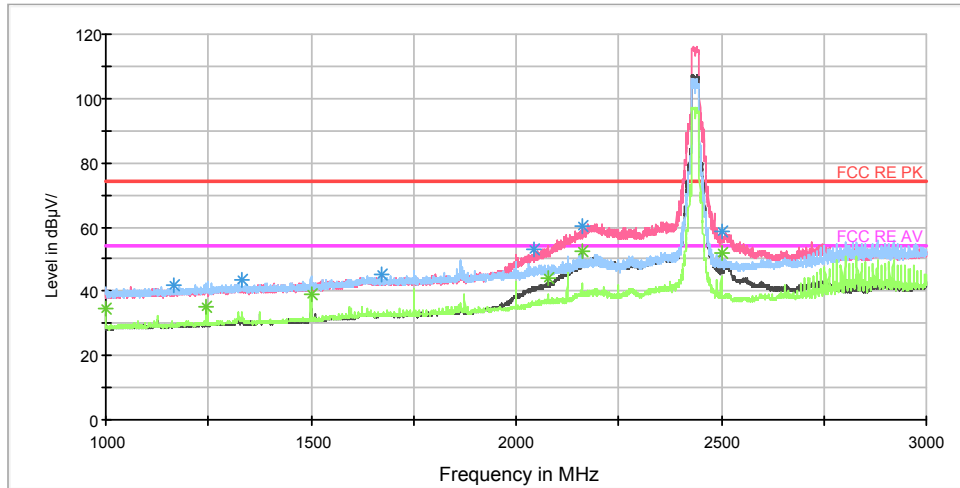

Note: The signal beyond the limit is carrier.

Radiates Emission from 1GHz to 3GHz

Frequency (MHz)	Peak (dBuV/m)	Height (cm)	Polarization	Azimuth (deg)	Reading value (dBuV/m)	Correct Factor (dB)	Margin (dB)	Limit (dBuV/m)
1166.500000	41.7	302.0	V	334.0	49.9	-8.2	32.3	74
1333.000000	43.3	302.0	H	148.0	50.7	-7.4	30.7	74
1672.500000	45.4	202.0	V	173.0	50.5	-5.1	28.6	74
2043.000000	53.2	202.0	V	69.0	56.4	-3.2	20.8	74
2160.000000	60.4	202.0	V	259.0	62.6	-2.2	13.6	74
2500.000000	58.9	202.0	V	105.0	59.1	-0.2	15.1	74

Remark: 1. Correction Factor = Antenna factor+ Insertion loss (cable loss + amplifier gain)

Frequency (MHz)	Average (dBuV/m)	Height (cm)	Polarization	Azimuth (deg)	Reading value (dBuV/m)	Correct Factor (dB)	Margin (dB)	Limit (dBuV/m)
1000.250000	34.9	302.0	H	160.0	44.1	-9.2	19.1	54
1244.250000	34.9	302.0	H	129.0	42.9	-8.0	19.1	54
1500.000000	38.9	202.0	H	252.0	45.6	-6.7	15.1	54
2080.000000	44.1	202.0	V	81.0	47.1	-3.0	9.9	54
2160.000000	52.5	202.0	V	259.0	54.7	-2.2	1.5	54
2500.250000	52.1	202.0	V	9.0	52.3	-0.2	1.9	54

Remark: 1. Correction Factor = Antenna factor+ Insertion loss (cable loss + amplifier gain)

RE 3-18GHz PK+AV

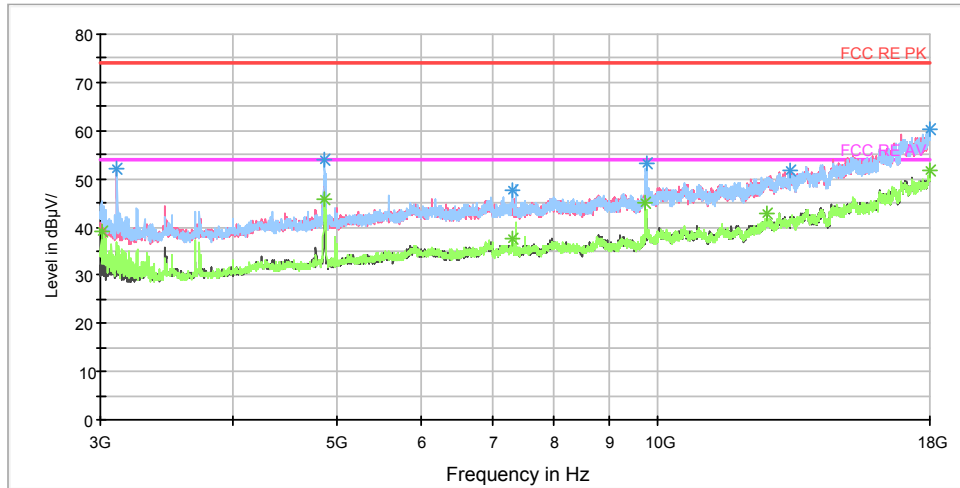

Radiates Emission from 3GHz to 18GHz

Frequency (MHz)	Peak (dBuV/m)	Height (cm)	Polarization	Azimuth (deg)	Reading value (dBuV/m)	Correct Factor (dB)	Margin (dB)	Limit (dBuV/m)
3016.875000	44.7	202.0	H	115.0	46.6	-1.9	29.3	74
4873.125000	53.9	202.0	H	235.0	56.9	3.0	20.1	74
7316.250000	45.9	202.0	H	151.0	54.4	8.5	28.1	74
9742.500000	51.3	202.0	H	175.0	62.9	11.6	22.7	74
12658.125000	49.6	302.0	V	67.0	64.5	14.9	24.4	74
17990.625000	59.3	202.0	V	294.0	84.6	25.3	14.7	74

Remark: 1. Correction Factor = Antenna factor+ Insertion loss (cable loss + amplifier gain)

Frequency (MHz)	Average (dBuV/m)	Height (cm)	Polarization	Azimuth (deg)	Reading value (dBuV/m)	Correct Factor (dB)	Margin (dB)	Limit (dBuV/m)
3016.875000	39.1	202.0	H	115.0	41.0	-1.9	14.9	54
4873.125000	45.8	202.0	H	235.0	48.8	3.0	8.2	54
7316.250000	37.7	202.0	H	151.0	46.2	8.5	16.3	54
9742.500000	45.1	202.0	H	175.0	56.7	11.6	8.9	54
12658.125000	42.9	302.0	V	67.0	57.8	14.9	11.1	54
17990.625000	51.6	202.0	V	294.0	76.9	25.3	2.4	54

Remark: 1. Correction Factor = Antenna factor+ Insertion loss (cable loss + amplifier gain)

RE 18-26.5GHz PK+AV

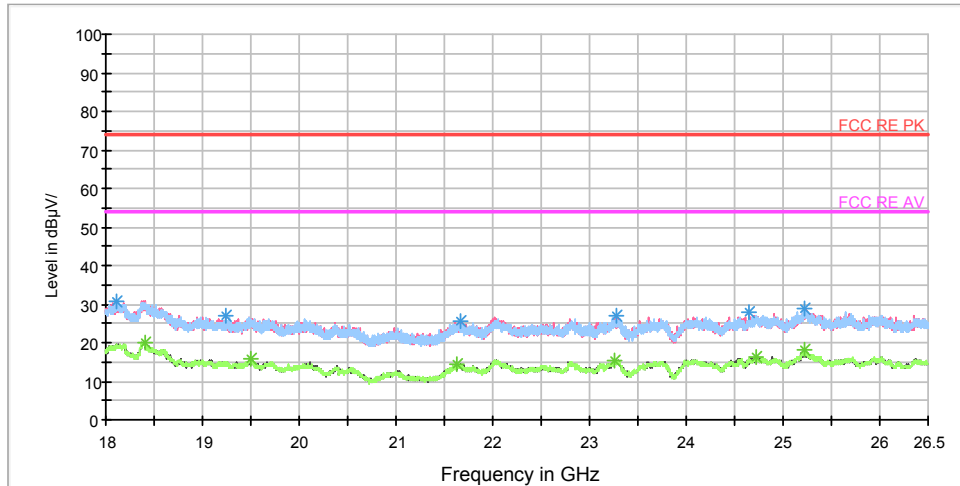

Radiates Emission from 18GHz to 26.5GHz

Frequency (MHz)	Peak (dBuV/m)	Polarization	Azimuth (deg)	Reading value (dBuV/m)	Correct Factor (dB)	Margin (dB)	Limit (dBuV/m)
18112.625000	30.8	H	33.0	35.9	-5.1	43.2	74
19238.875000	26.9	V	15.0	33.7	-6.8	47.1	74
21662.437500	25.7	V	105.0	35.0	-9.3	48.3	74
23271.062500	27.1	V	300.0	34.3	-7.2	46.9	74
24654.437500	27.9	H	57.0	34.9	-7.0	46.1	74
25217.562500	29.1	H	33.0	35.2	-6.1	44.9	74

Remark: 1. Correction Factor = Antenna factor+ Insertion loss (cable loss + amplifier gain)

Frequency (MHz)	Average (dBuV/m)	Polarization	Azimuth (deg)	Reading value (dBuV/m)	Correct Factor (dB)	Margin (dB)	Limit (dBuV/m)
18411.187500	20.1	H	78.0	25.1	-5.0	33.9	54
19504.500000	15.9	H	166.0	23.4	-7.5	38.1	54
21636.937500	14.3	V	286.0	23.4	-9.1	39.7	54
23266.812500	15.5	H	103.0	22.8	-7.3	38.5	54
24728.812500	16.5	H	25.0	22.7	-6.2	37.5	54
25221.812500	18.0	V	242.0	23.9	-5.9	36.0	54

Remark: 1. Correction Factor = Antenna factor+ Insertion loss (cable loss + amplifier gain)

802.11n (HT20) CH11

FCC RE 0.03-1GHz QP Class B

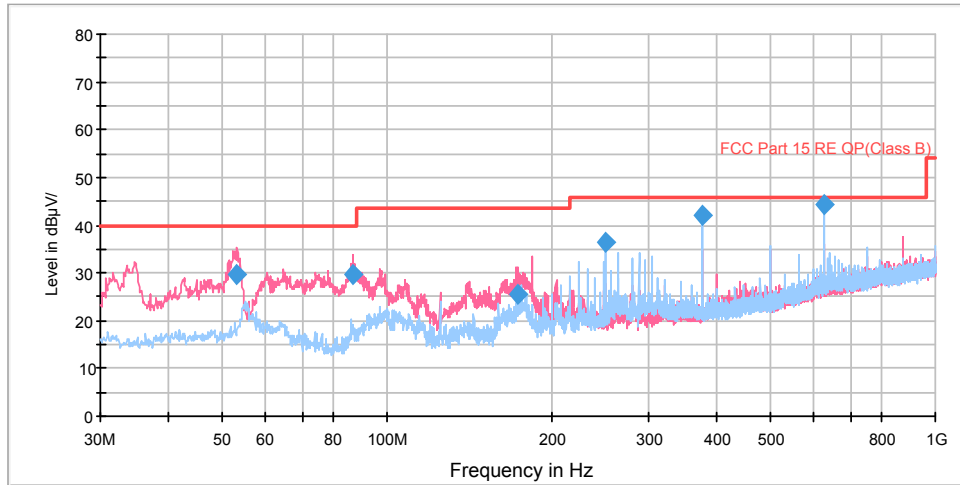

Radiates Emission from 30MHz to 1GHz

Frequency (MHz)	Quasi-Peak (dBuV/m)	Height (cm)	Polarization	Azimuth (deg)	Reading value (dBuV/m)	Correct Factor (dB)	Margin (dB)	Limit (dBuV/m)
53.120000	29.6	100.0	V	277.0	42.4	12.8	10.4	40.0
86.746250	29.6	125.0	V	134.0	40.4	10.8	10.4	40.0
172.625000	25.7	100.0	V	42.0	36.1	10.4	17.8	43.5
249.987500	36.4	100.0	H	0.0	50.5	14.1	9.6	46.0
374.996250	42.1	100.0	H	147.0	59.5	17.4	3.9	46.0
625.015000	44.2	114.0	H	0.0	66.4	22.2	1.8	46.0

- Remark: 1. Quasi-Peak = Reading value + Correction factor
 2. Correction Factor = Antenna factor+ Insertion loss(cable loss+amplifier gain)
 3. Margin = Limit – Quasi-Peak

RE 1G-3GHz PK+AV

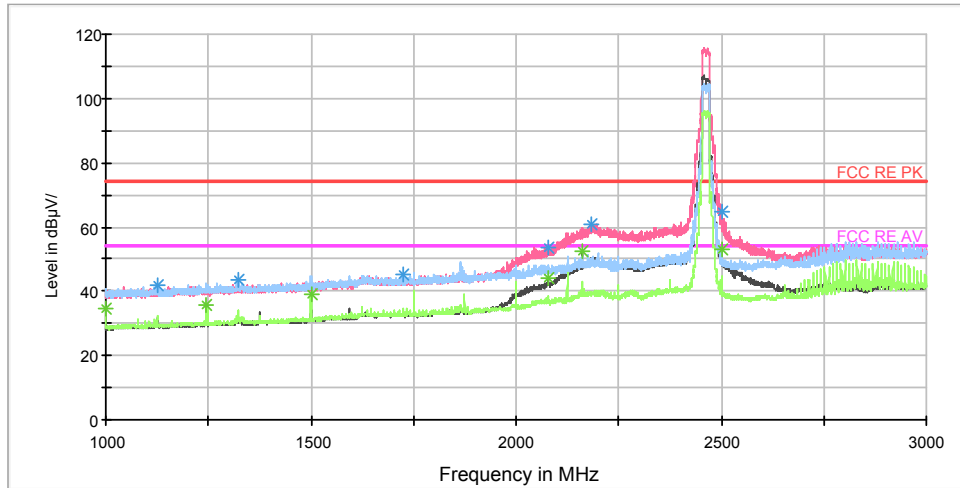

Note: The signal beyond the limit is carrier.

Radiates Emission from 1GHz to 3GHz

Frequency (MHz)	Peak (dBuV/m)	Height (cm)	Polarization	Azimuth (deg)	Reading value (dBuV/m)	Correct Factor (dB)	Margin (dB)	Limit (dBuV/m)
1125.000000	41.8	301.0	H	61.0	50.2	-8.4	32.2	74
1323.500000	43.5	301.0	H	210.0	50.8	-7.3	30.5	74
1724.500000	45.1	201.0	H	233.0	50.1	-5.0	28.9	74
2080.000000	53.6	301.0	V	0.0	56.6	-3.0	20.4	74
2500.000000	64.7	201.0	V	109.0	64.9	-0.2	9.3	74
2182.500000	61.0	201.0	V	0.0	63.2	-2.2	13.0	74

Remark: 1. Correction Factor = Antenna factor+ Insertion loss (cable loss + amplifier gain)

Frequency (MHz)	Average (dBuV/m)	Height (cm)	Polarization	Azimuth (deg)	Reading value (dBuV/m)	Correct Factor (dB)	Margin (dB)	Limit (dBuV/m)
1000.000000	34.5	301.0	H	180.0	43.7	-9.2	19.5	54
1244.250000	35.6	301.0	H	133.0	43.6	-8.0	18.4	54
1500.000000	39.0	201.0	H	252.0	45.7	-6.7	15.0	54
2080.000000	44.3	301.0	V	0.0	47.3	-3.0	9.7	54
2500.250000	53.1	201.0	V	324.0	53.3	-0.2	0.9	54
2160.000000	52.5	201.0	V	168.0	54.7	-2.2	1.5	54

Remark: 1. Correction Factor = Antenna factor+ Insertion loss (cable loss + amplifier gain)

RE 3-18GHz PK+AV

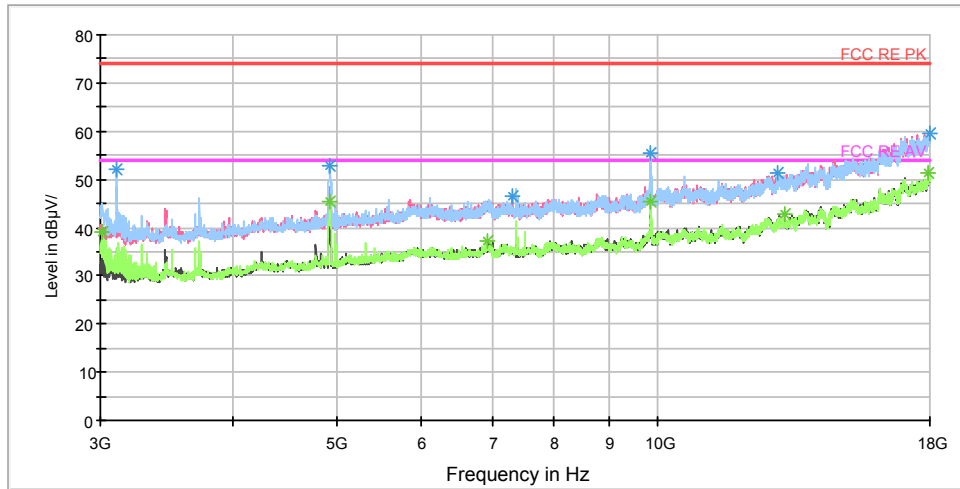

Radiates Emission from 3GHz to 18GHz

Frequency (MHz)	Peak (dBuV/m)	Height (cm)	Polarization	Azimuth (deg)	Reading value (dBuV/m)	Correct Factor (dB)	Margin (dB)	Limit (dBuV/m)
3016.875000	44.7	202.0	H	127.0	46.6	-1.9	29.3	74
4921.875000	52.2	202.0	H	163.0	55.3	3.1	21.8	74
6931.875000	44.0	302.0	V	0.0	50.8	6.8	30.0	74
9843.750000	52.6	202.0	H	175.0	64.4	11.8	21.4	74
13141.875000	48.9	102.0	V	190.0	64.6	15.7	25.1	74
17953.125000	57.3	203.0	V	99.0	82.2	24.9	16.7	74

Remark: 1. Correction Factor = Antenna factor+ Insertion loss (cable loss + amplifier gain)

Frequency (MHz)	Average (dBuV/m)	Height (cm)	Polarization	Azimuth (deg)	Reading value (dBuV/m)	Correct Factor (dB)	Margin (dB)	Limit (dBuV/m)
3016.875000	38.9	202.0	H	127.0	40.8	-1.9	15.1	54
4921.875000	45.4	202.0	H	163.0	48.5	3.1	8.6	54
6931.875000	37.2	302.0	V	0.0	44.0	6.8	16.8	54
9843.750000	45.4	202.0	H	175.0	57.2	11.8	8.6	54
13141.875000	43.0	102.0	V	190.0	58.7	15.7	11.0	54
17953.125000	51.2	203.0	V	99.0	76.1	24.9	2.8	54

Remark: 1. Correction Factor = Antenna factor+ Insertion loss (cable loss + amplifier gain)

RE 18-26.5GHz PK+AV

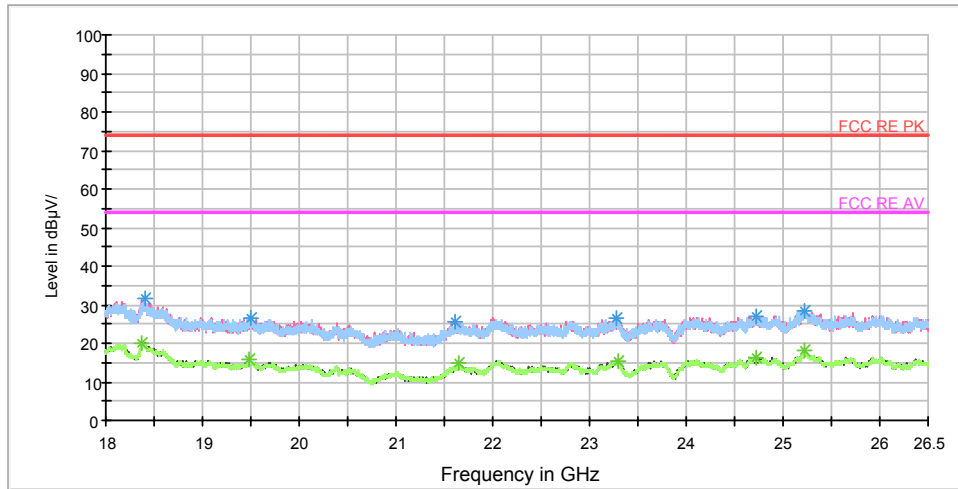

Radiates Emission from 18GHz to 26.5GHz

Frequency (MHz)	Peak (dBuV/m)	Polarization	Azimuth (deg)	Reading value (dBuV/m)	Correct Factor (dB)	Margin (dB)	Limit (dBuV/m)
18409.062500	31.6	H	48.0	36.6	-5.0	42.4	74
19492.812500	26.7	V	145.0	34.3	-7.6	47.3	74
21619.937500	25.4	V	300.0	34.4	-9.0	48.6	74
23274.250000	26.6	H	140.0	33.8	-7.2	47.4	74
24725.625000	27.1	H	25.0	33.3	-6.2	46.9	74
25229.250000	28.4	V	252.0	34.3	-5.9	45.6	74

Remark: 1. Correction Factor = Antenna factor+ Insertion loss (cable loss + amplifier gain)

Frequency (MHz)	Average (dBuV/m)	Polarization	Azimuth (deg)	Reading value (dBuV/m)	Correct Factor (dB)	Margin (dB)	Limit (dBuV/m)
18371.875000	20.2	H	132.0	25.0	-4.8	33.8	54
19490.687500	15.9	V	66.0	23.5	-7.6	38.1	54
21643.312500	14.7	H	55.0	23.8	-9.1	39.3	54
23290.187500	15.5	H	125.0	22.5	-7.0	38.5	54
24723.500000	16.4	H	25.0	22.6	-6.2	37.6	54
25231.375000	17.9	V	260.0	23.8	-5.9	36.1	54

Remark: 1. Correction Factor = Antenna factor+ Insertion loss (cable loss + amplifier gain)



802.11n (HT40) CH3

RE 30M-1GHz QP

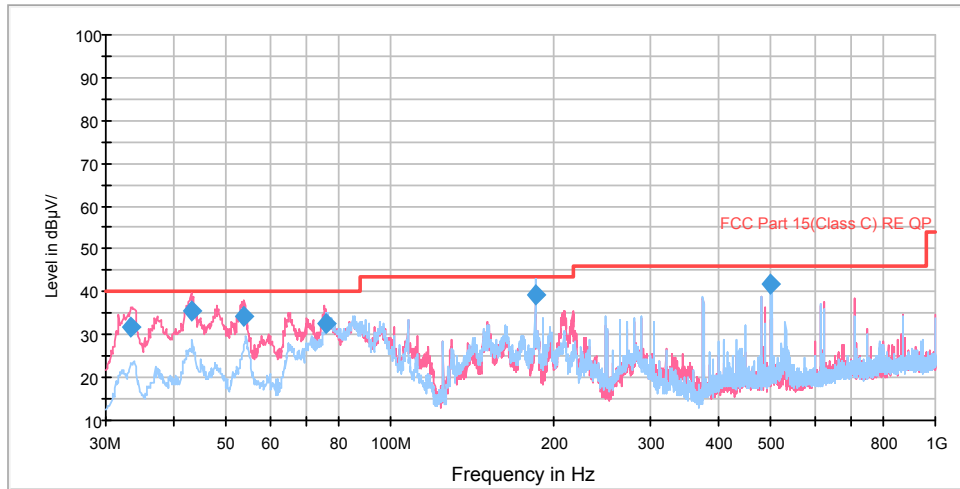

Radiates Emission from 30MHz to 1GHz

Frequency (MHz)	Quasi-Peak (dBuV/m)	Height (cm)	Polarization	Azimuth (deg)	Reading value (dBuV/m)	Correct Factor (dB)	Margin (dB)	Limit (dBuV/m)
33.431512	31.9	101.0	V	112.0	54.5	-22.6	8.1	40.0
43.107262	35.6	101.0	V	167.0	56.2	-20.6	4.4	40.0
53.791534	34.1	101.0	V	167.0	54.9	-20.8	5.9	40.0
75.900528	32.8	204.0	V	118.0	61.5	-28.7	7.2	40.0
184.249425	39.3	198.0	H	137.0	66.9	-27.6	4.2	43.5
499.996250	41.7	102.0	H	224.0	60.7	-19.0	4.3	46.0

- Remark: 1. Quasi-Peak = Reading value + Correction factor
 2. Correction Factor = Antenna factor+ Insertion loss(cable loss+amplifier gain)
 3. Margin = Limit – Quasi-Peak

RE 1G-3GHz PK+AV

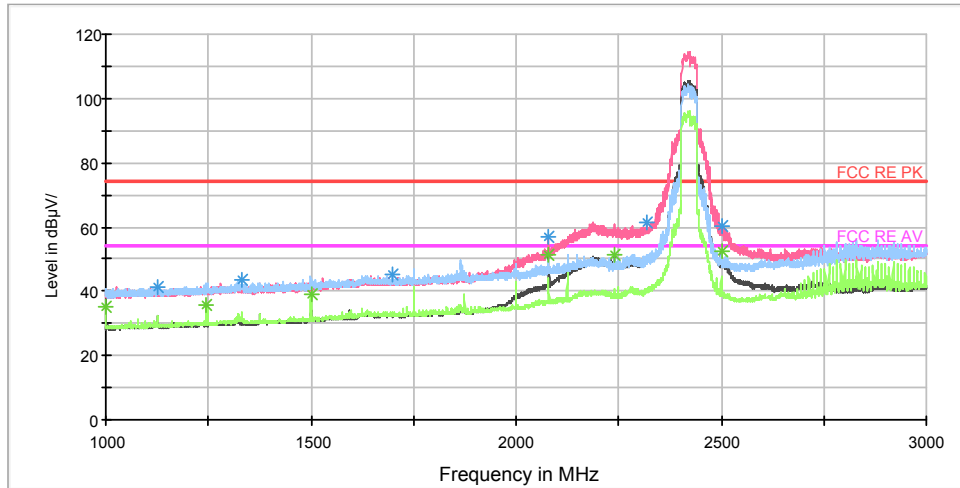

Note: The signal beyond the limit is carrier.

Radiates Emission from 1GHz to 3GHz

Frequency (MHz)	Peak (dBuV/m)	Height (cm)	Polarization	Azimuth (deg)	Reading value (dBuV/m)	Correct Factor (dB)	Margin (dB)	Limit (dBuV/m)
1125.000000	41.5	201.0	V	151.0	49.9	-8.4	32.5	74
1332.750000	43.6	301.0	H	154.0	51.0	-7.4	30.4	74
1698.500000	45.1	201.0	H	249.0	50.1	-5.0	28.9	74
2080.000000	57.2	301.0	V	359.0	60.2	-3.0	16.8	74
2500.000000	60.5	201.0	V	157.0	60.7	-0.2	13.5	74
2319.750000	61.2	201.0	V	225.0	62.9	-1.7	12.8	74

Remark: 1. Correction Factor = Antenna factor+ Insertion loss (cable loss + amplifier gain)

Frequency (MHz)	Average (dBuV/m)	Height (cm)	Polarization	Azimuth (deg)	Reading value (dBuV/m)	Correct Factor (dB)	Margin (dB)	Limit (dBuV/m)
1000.000000	35.2	301.0	H	154.0	44.4	-9.2	18.8	54
1244.250000	35.6	301.0	H	118.0	43.6	-8.0	18.4	54
1500.000000	38.9	201.0	H	249.0	45.6	-6.7	15.1	54
2080.000000	51.1	301.0	V	359.0	54.1	-3.0	2.9	54
2500.000000	52.7	201.0	V	157.0	52.9	-0.2	1.3	54
2240.000000	51.5	201.0	V	346.0	54.1	-2.6	2.5	54

Remark: 1. Correction Factor = Antenna factor+ Insertion loss (cable loss + amplifier gain)



RE 3-18GHz PK+AV

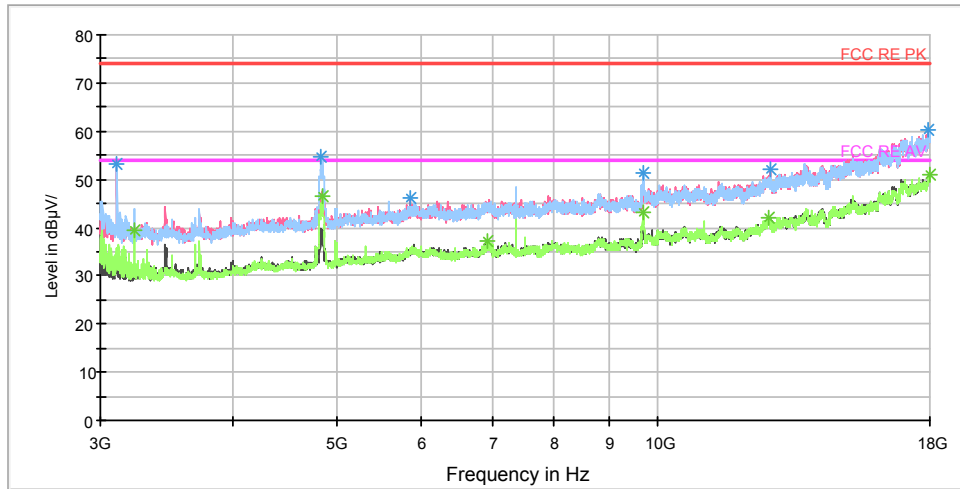

Radiates Emission from 3GHz to 18GHz

Frequency (MHz)	Peak (dBuV/m)	Height (cm)	Polarization	Azimuth (deg)	Reading value (dBuV/m)	Correct Factor (dB)	Margin (dB)	Limit (dBuV/m)
3228.750000	43.8	202.0	H	176.0	45.4	-1.6	30.2	74
4845.000000	54.2	202.0	H	240.0	57.1	2.9	19.8	74
6913.125000	43.7	202.0	V	136.0	50.6	6.9	30.3	74
9699.375000	51.2	202.0	H	146.0	62.2	11.0	22.8	74
12718.125000	49.7	302.0	V	0.0	64.8	15.1	24.3	74
17990.625000	57.9	302.0	V	293.0	83.2	25.3	16.1	74

Remark: 1. Correction Factor = Antenna factor+ Insertion loss (cable loss + amplifier gain)

Frequency (MHz)	Average (dBuV/m)	Height (cm)	Polarization	Azimuth (deg)	Reading value (dBuV/m)	Correct Factor (dB)	Margin (dB)	Limit (dBuV/m)
3228.750000	39.4	202.0	H	176.0	41.0	-1.6	14.6	54
4845.000000	46.6	202.0	H	240.0	49.5	2.9	7.4	54
6913.125000	37.1	202.0	V	136.0	44.0	6.9	16.9	54
9699.375000	43.1	202.0	H	146.0	54.1	11.0	10.9	54
12718.125000	42.2	302.0	V	0.0	57.3	15.1	11.8	54
17990.625000	51.1	302.0	V	293.0	76.4	25.3	2.9	54

Remark: 1. Correction Factor = Antenna factor+ Insertion loss (cable loss + amplifier gain)

RE 18-26.5GHz PK+AV

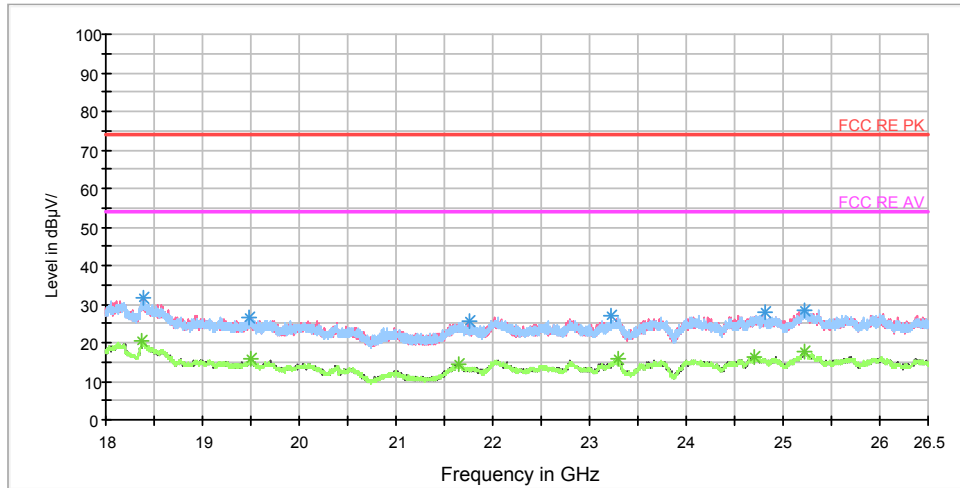

Radiates Emission from 18GHz to 26.5GHz

Frequency (MHz)	Peak (dBuV/m)	Polarization	Azimuth (deg)	Reading value (dBuV/m)	Correct Factor (dB)	Margin (dB)	Limit (dBuV/m)
18392.062500	31.6	V	248.0	36.5	-4.9	42.4	74
19476.875000	26.5	H	85.0	34.3	-7.8	47.5	74
21759.125000	25.6	V	219.0	35.0	-9.4	48.4	74
23225.375000	26.9	V	72.0	35.2	-8.3	47.1	74
24806.375000	27.9	H	3.0	34.6	-6.7	46.1	74
25227.125000	28.5	V	65.0	34.4	-5.9	45.5	74

Remark: 1. Correction Factor = Antenna factor+ Insertion loss (cable loss + amplifier gain)

Frequency (MHz)	Average (dBuV/m)	Polarization	Azimuth (deg)	Reading value (dBuV/m)	Correct Factor (dB)	Margin (dB)	Limit (dBuV/m)
18375.062500	20.3	H	108.0	25.0	-4.7	33.7	54
19497.062500	15.7	V	0.0	23.2	-7.5	38.3	54
21647.562500	14.3	V	294.0	23.5	-9.2	39.7	54
23288.062500	15.6	V	300.0	22.7	-7.1	38.4	54
24712.875000	16.2	V	226.0	22.7	-6.5	37.8	54
25218.625000	17.8	H	3.0	23.8	-6.0	36.2	54

Remark: 1. Correction Factor = Antenna factor+ Insertion loss (cable loss + amplifier gain)

802.11n (HT40) CH6

RE 30M-1GHz QP

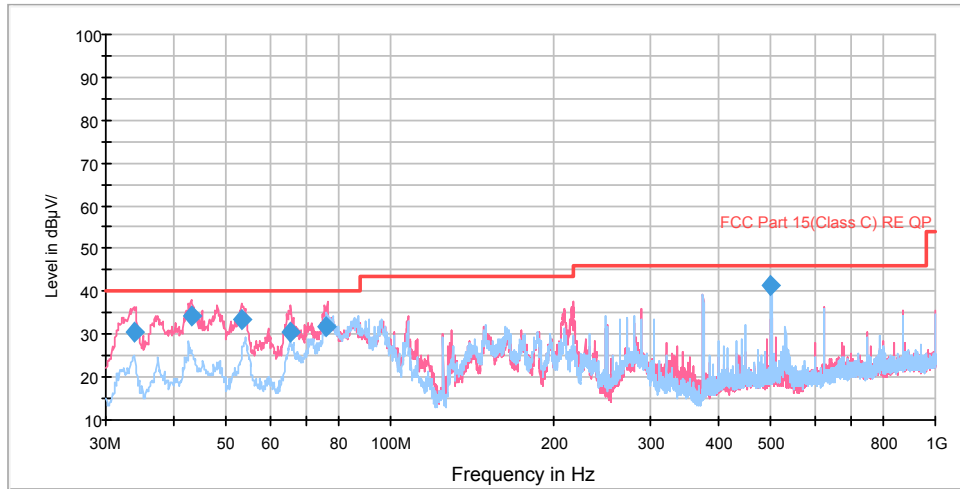

Radiates Emission from 30MHz to 1GHz

Frequency (MHz)	Quasi-Peak (dBuV/m)	Height (cm)	Polarization	Azimuth (deg)	Reading value (dBuV/m)	Correct Factor (dB)	Margin (dB)	Limit (dBuV/m)
33.916247	30.6	100.0	V	141.0	53.2	-22.6	9.4	40.0
43.067262	34.5	100.0	V	178.0	55.1	-20.6	5.5	40.0
53.291647	33.6	100.0	V	120.0	54.3	-20.7	6.4	40.0
65.483382	30.4	101.0	V	197.0	54.5	-24.1	9.6	40.0
76.368600	31.8	179.0	V	114.0	60.5	-28.7	8.2	40.0
499.995000	41.4	102.0	H	226.0	60.4	-19.0	4.6	46.0

- Remark: 1. Quasi-Peak = Reading value + Correction factor
 2. Correction Factor = Antenna factor+ Insertion loss(cable loss+amplifier gain)
 3. Margin = Limit – Quasi-Peak

RE 1G-3GHz PK+AV

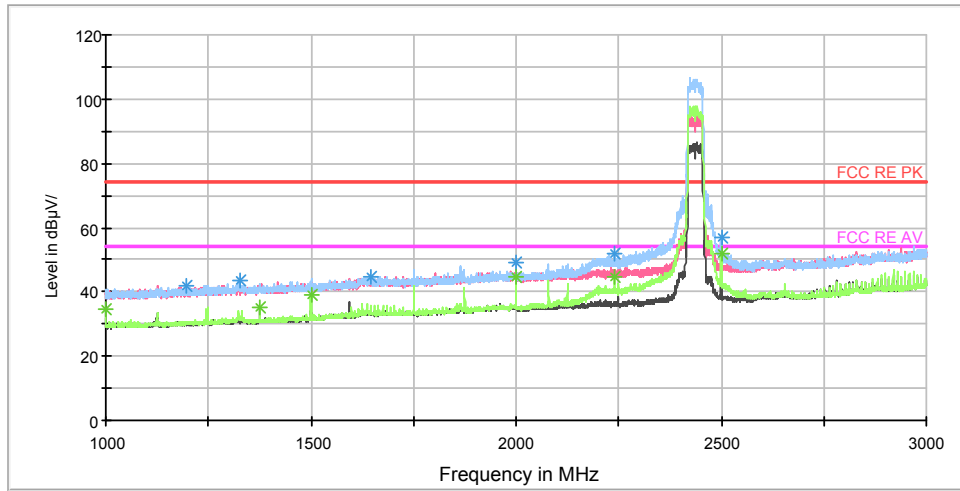

Note: The signal beyond the limit is carrier.

Radiates Emission from 1GHz to 3GHz

Frequency (MHz)	Peak (dBuV/m)	Height (cm)	Polarization	Azimuth (deg)	Reading value (dBuV/m)	Correct Factor (dB)	Margin (dB)	Limit (dBuV/m)
1000.000000	40.8	201.0	H	325.0	50.0	-9.2	33.2	74
1375.000000	41.7	101.0	V	184.0	48.8	-7.1	32.3	74
1500.000000	43.7	201.0	H	289.0	50.4	-6.7	30.3	74
1999.750000	48.9	201.0	H	316.0	52.3	-3.4	25.1	74
2240.000000	50.6	101.0	H	149.0	53.2	-2.6	23.4	74
2500.000000	56.7	101.0	H	178.0	56.9	-0.2	17.3	74

Remark: 1. Correction Factor = Antenna factor+ Insertion loss (cable loss + amplifier gain)

Frequency (MHz)	Average (dBuV/m)	Height (cm)	Polarization	Azimuth (deg)	Reading value (dBuV/m)	Correct Factor (dB)	Margin (dB)	Limit (dBuV/m)
1000.000000	34.5	201.0	H	325.0	43.7	-9.2	19.5	54
1375.000000	35.3	101.0	V	184.0	42.4	-7.1	18.7	54
1500.000000	39.0	201.0	H	289.0	45.7	-6.7	15.0	54
1999.750000	44.7	201.0	H	316.0	48.1	-3.4	9.3	54
2240.000000	44.9	101.0	H	149.0	47.5	-2.6	9.1	54
2500.000000	52.0	101.0	H	178.0	52.2	-0.2	2.0	54

Remark: 1. Correction Factor = Antenna factor+ Insertion loss (cable loss + amplifier gain)

RE 3-18GHz PK+AV

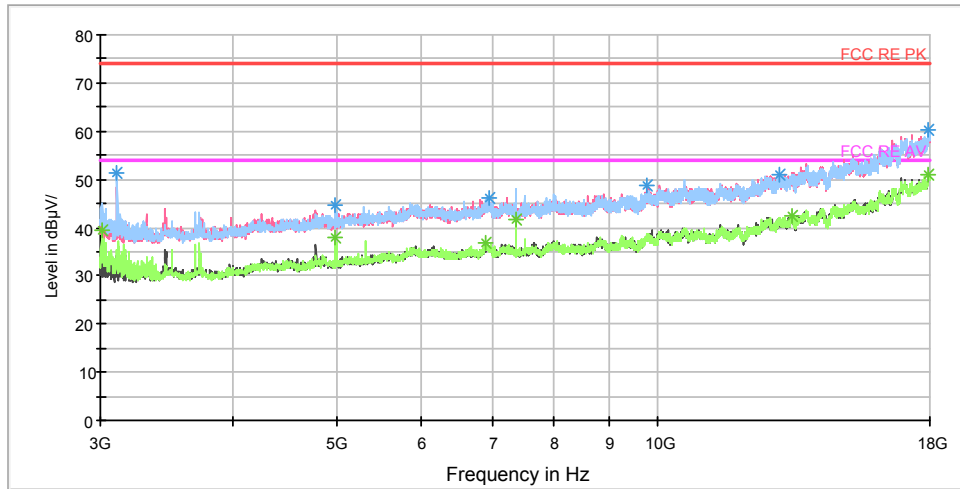

Radiates Emission from 3GHz to 18GHz

Frequency (MHz)	Peak (dBuV/m)	Height (cm)	Polarization	Azimuth (deg)	Reading value (dBuV/m)	Correct Factor (dB)	Margin (dB)	Limit (dBuV/m)
3016.875000	45.0	201.0	H	118.0	46.9	-1.9	29.0	74
4976.250000	44.6	201.0	H	257.0	47.6	3.0	29.4	74
6905.625000	43.8	201.0	H	199.0	50.7	6.9	30.2	74
7372.500000	47.9	201.0	H	211.0	56.0	8.1	26.1	74
13348.125000	51.0	302.0	V	223.0	66.8	15.8	23.0	74
17955.000000	57.2	302.0	H	0.0	82.1	24.9	16.8	74

Remark: 1. Correction Factor = Antenna factor+ Insertion loss (cable loss + amplifier gain)

Frequency (MHz)	Average (dBuV/m)	Height (cm)	Polarization	Azimuth (deg)	Reading value (dBuV/m)	Correct Factor (dB)	Margin (dB)	Limit (dBuV/m)
3016.875000	39.4	201.0	H	118.0	41.3	-1.9	14.6	54
4976.250000	37.9	201.0	H	257.0	40.9	3.0	16.1	54
6905.625000	36.7	201.0	H	199.0	43.6	6.9	17.3	54
7372.500000	41.6	201.0	H	211.0	49.7	8.1	12.4	54
13348.125000	42.3	302.0	V	223.0	58.1	15.8	11.7	54
17955.000000	51.0	302.0	H	0.0	75.9	24.9	3.0	54

Remark: 1. Correction Factor = Antenna factor+ Insertion loss (cable loss + amplifier gain)

RE 18-26.5GHz PK+AV

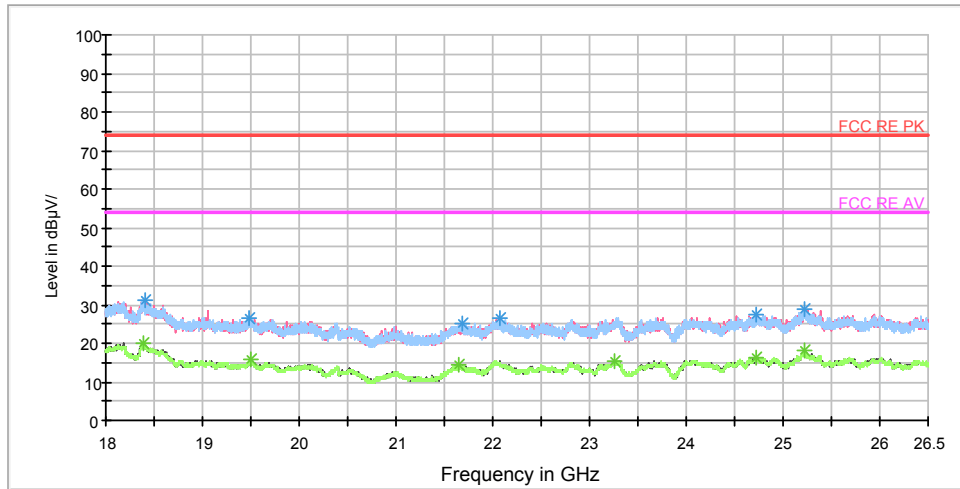

Radiates Emission from 18GHz to 26.5GHz

Frequency (MHz)	Peak (dBuV/m)	Polarization	Azimuth (deg)	Reading value (dBuV/m)	Correct Factor (dB)	Margin (dB)	Limit (dBuV/m)
18410.125000	31.2	H	0.0	36.2	-5.0	42.8	74
19477.937500	26.4	V	144.0	34.2	-7.8	47.6	74
21686.875000	25.1	H	2.0	34.5	-9.4	48.9	74
22065.125000	26.4	H	126.0	34.5	-8.1	47.6	74
24722.437500	27.6	H	50.0	33.8	-6.2	46.4	74
25218.625000	28.7	H	112.0	34.7	-6.0	45.3	74

Remark: 1. Correction Factor = Antenna factor+ Insertion loss (cable loss + amplifier gain)

Frequency (MHz)	Average (dBuV/m)	Polarization	Azimuth (deg)	Reading value (dBuV/m)	Correct Factor (dB)	Margin (dB)	Limit (dBuV/m)
18394.187500	20.1	V	50.0	25.0	-4.9	33.9	54
19501.312500	15.7	H	157.0	23.2	-7.5	38.3	54
21647.562500	14.4	V	292.0	23.6	-9.2	39.6	54
23253.000000	15.5	V	121.0	23.0	-7.5	38.5	54
24725.625000	16.5	V	129.0	22.7	-6.2	37.5	54
25231.375000	17.9	H	0.0	23.8	-5.9	36.1	54

Remark: 1. Correction Factor = Antenna factor+ Insertion loss (cable loss + amplifier gain)

802.11n (HT40) CH9

RE 30M-1GHz QP

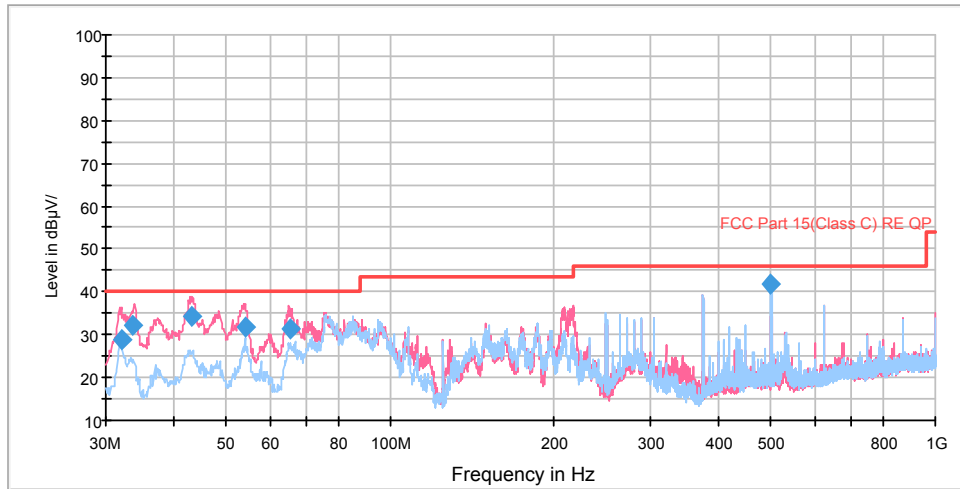

Radiates Emission from 30MHz to 1GHz

Frequency (MHz)	Quasi-Peak (dBuV/m)	Height (cm)	Polarization	Azimuth (deg)	Reading value (dBuV/m)	Correct Factor (dB)	Margin (dB)	Limit (dBuV/m)
32.141403	28.9	178.0	V	160.0	51.4	-22.5	11.1	40.0
33.674353	32.0	101.0	V	126.0	54.6	-22.6	8.0	40.0
43.228210	34.4	101.0	V	195.0	55.1	-20.7	5.6	40.0
53.993428	31.8	101.0	V	256.0	52.7	-20.9	8.2	40.0
65.325406	31.5	101.0	V	188.0	55.5	-24.0	8.5	40.0
499.996250	41.8	101.0	H	224.0	60.8	-19.0	4.2	46.0

- Remark: 1. Quasi-Peak = Reading value + Correction factor
 2. Correction Factor = Antenna factor+ Insertion loss(cable loss+amplifier gain)
 3. Margin = Limit – Quasi-Peak

RE 1G-3GHz PK+AV

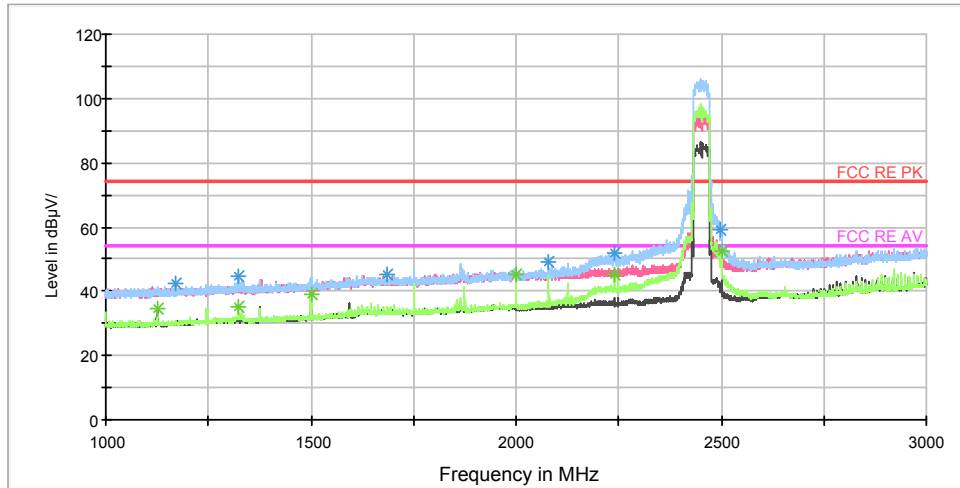

Note: The signal beyond the limit is carrier.
Radiates Emission from 1GHz to 3GHz

Frequency (MHz)	Peak (dBuV/m)	Height (cm)	Polarization	Azimuth (deg)	Reading value (dBuV/m)	Correct Factor (dB)	Margin (dB)	Limit (dBuV/m)
1124.750000	40.4	101.0	V	186.0	48.8	-8.4	33.6	74
1323.250000	44.4	101.0	H	154.0	51.7	-7.3	29.6	74
1500.000000	44.9	201.0	H	300.0	51.6	-6.7	29.1	74
1999.750000	48.6	201.0	H	318.0	52.0	-3.4	25.4	74
2240.000000	51.8	101.0	H	154.0	54.4	-2.6	22.2	74
2500.000000	58.3	101.0	H	173.0	58.5	-0.2	15.7	74

Remark: 1. Correction Factor = Antenna factor+ Insertion loss (cable loss + amplifier gain)

Frequency (MHz)	Average (dBuV/m)	Height (cm)	Polarization	Azimuth (deg)	Reading value (dBuV/m)	Correct Factor (dB)	Margin (dB)	Limit (dBuV/m)
1124.750000	34.4	101.0	V	186.0	42.8	-8.4	19.6	54
1323.250000	35.3	101.0	H	154.0	42.6	-7.3	18.7	54
1500.000000	39.0	201.0	H	300.0	45.7	-6.7	15.0	54
1999.750000	45.2	201.0	H	318.0	48.6	-3.4	8.8	54
2240.000000	45.4	101.0	H	154.0	48.0	-2.6	8.6	54
2500.000000	52.5	101.0	H	173.0	52.7	-0.2	1.5	54

Remark: 1. Correction Factor = Antenna factor+ Insertion loss (cable loss + amplifier gain)

RE 3-18GHz PK+AV

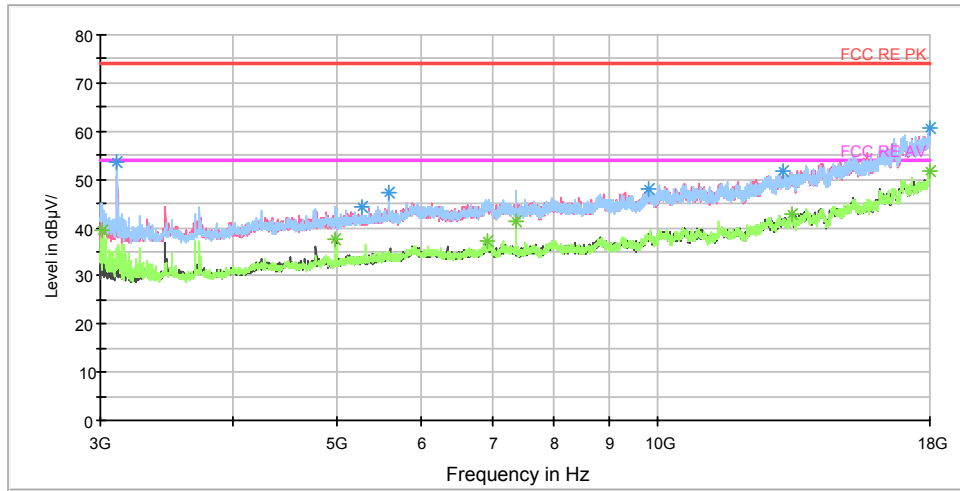

Radiates Emission from 3GHz to 18GHz

Frequency (MHz)	Peak (dBuV/m)	Height (cm)	Polarization	Azimuth (deg)	Reading value (dBuV/m)	Correct Factor (dB)	Margin (dB)	Limit (dBuV/m)
3016.875000	44.8	202.0	H	152.0	46.7	-1.9	29.2	74
4976.250000	43.5	202.0	H	257.0	46.5	3.0	30.5	74
6916.875000	43.4	102.0	V	290.0	50.3	6.9	30.6	74
7372.500000	47.6	202.0	H	211.0	55.7	8.1	26.4	74
13348.125000	48.6	202.0	V	0.0	64.4	15.8	25.4	74
17994.375000	57.3	102.0	V	358.0	82.6	25.3	16.7	74

Remark: 1. Correction Factor = Antenna factor+ Insertion loss (cable loss + amplifier gain)

Frequency (MHz)	Average (dBuV/m)	Height (cm)	Polarization	Azimuth (deg)	Reading value (dBuV/m)	Correct Factor (dB)	Margin (dB)	Limit (dBuV/m)
3016.875000	39.3	202.0	H	152.0	41.2	-1.9	14.7	54
4976.250000	37.5	202.0	H	257.0	40.5	3.0	16.5	54
6916.875000	37.3	102.0	V	290.0	44.2	6.9	16.7	54
7372.500000	41.4	202.0	H	211.0	49.5	8.1	12.6	54
13348.125000	42.8	202.0	V	0.0	58.6	15.8	11.2	54
17994.375000	51.7	102.0	V	358.0	77.0	25.3	2.3	54

Remark: 1. Correction Factor = Antenna factor+ Insertion loss (cable loss + amplifier gain)

RE 18-26.5GHz PK+AV

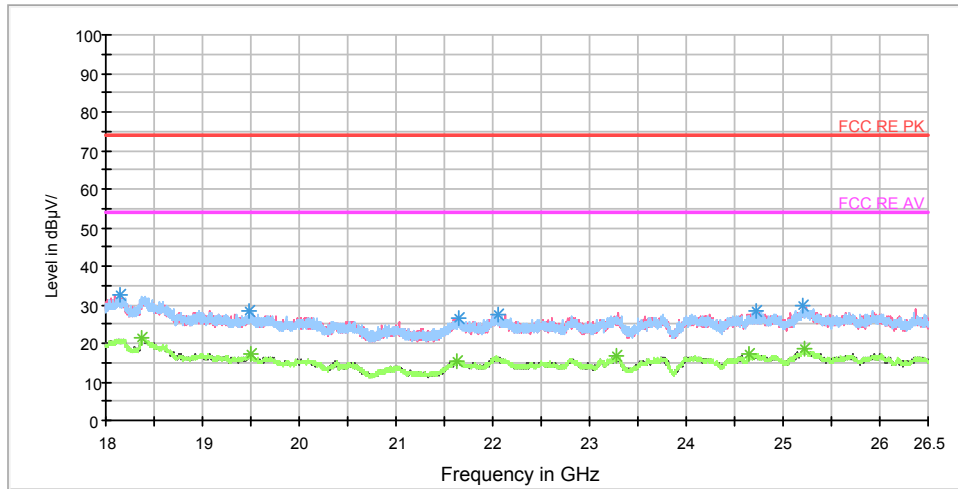

Radiates Emission from 18GHz to 26.5GHz

Frequency (MHz)	Peak (dBuV/m)	Polarization	Azimuth (deg)	Reading value (dBuV/m)	Correct Factor (dB)	Margin (dB)	Limit (dBuV/m)
18378.250000	30.9	V	180.0	35.7	-4.8	43.1	74
19497.062500	26.2	H	131.0	33.7	-7.5	47.8	74
21634.812500	25.2	V	175.0	34.3	-9.1	48.8	74
23276.375000	25.3	V	167.0	32.5	-7.2	48.7	74
24645.937500	27.0	H	0.0	34.1	-7.1	47.0	74
25223.937500	27.5	V	180.0	33.4	-5.9	46.5	74

Remark: 1. Correction Factor = Antenna factor+ Insertion loss (cable loss + amplifier gain)

Frequency (MHz)	Average (dBuV/m)	Polarization	Azimuth (deg)	Reading value (dBuV/m)	Correct Factor (dB)	Margin (dB)	Limit (dBuV/m)
18378.250000	21.6	V	180.0	26.4	-4.8	32.4	54
19497.062500	17.3	H	131.0	24.8	-7.5	36.7	54
21634.812500	15.5	V	175.0	24.6	-9.1	38.5	54
23276.375000	16.7	V	167.0	23.9	-7.2	37.3	54
24645.937500	17.3	H	0.0	24.4	-7.1	36.7	54
25223.937500	18.8	V	180.0	24.7	-5.9	35.2	54

Remark: 1. Correction Factor = Antenna factor+ Insertion loss (cable loss + amplifier gain)

Zigbee CH11

RE 0.03-1GHz QP Class B

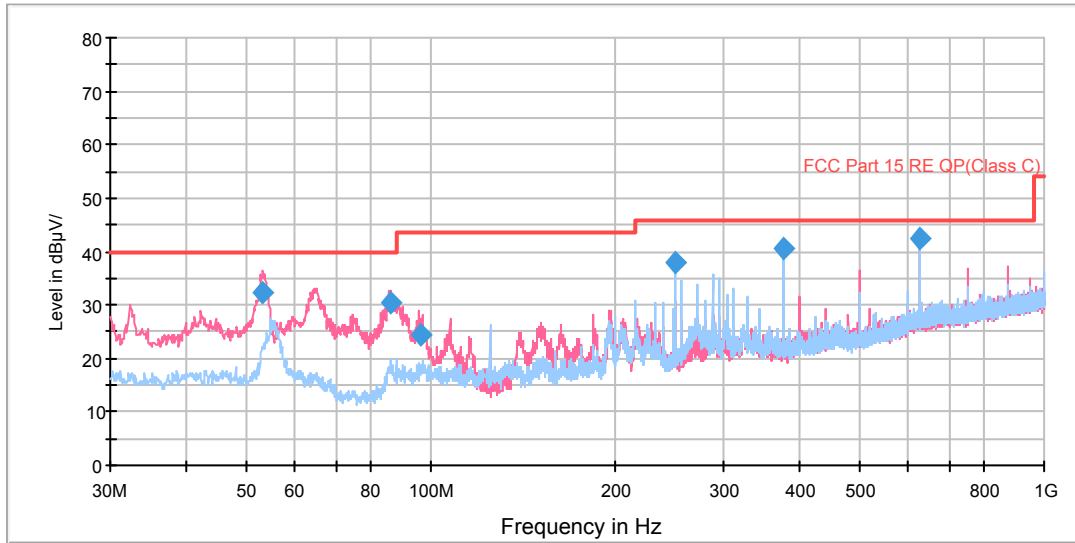

Radiates Emission from 30MHz to 1GHz

Frequency (MHz)	Quasi-Peak (dBuV/m)	Height (cm)	Polarization	Azimuth (deg)	Reading value (dBuV/m)	Correct Factor (dB)	Margin (dB)	Limit (dBuV/m)
53.200000	32.4	101.0	V	320.0	45.2	12.8	7.6	40.0
86.216250	30.3	115.0	V	303.0	40.9	10.6	9.7	40.0
96.247500	24.5	101.0	V	244.0	37.2	12.7	19.0	43.5
249.987500	38.1	101.0	H	25.0	52.2	14.1	7.9	46.0
374.996250	40.6	101.0	H	187.0	58.0	17.4	5.4	46.0
625.015000	42.4	126.0	H	352.0	64.6	22.2	3.6	46.0

- Remark:**
1. Quasi-Peak = Reading value + Correction factor
 2. Correction Factor = Antenna factor+ Insertion loss(cable loss+amplifier gain)
 3. Margin = Limit – Quasi-Peak

RE 1G-6GHz PK+AV Class B

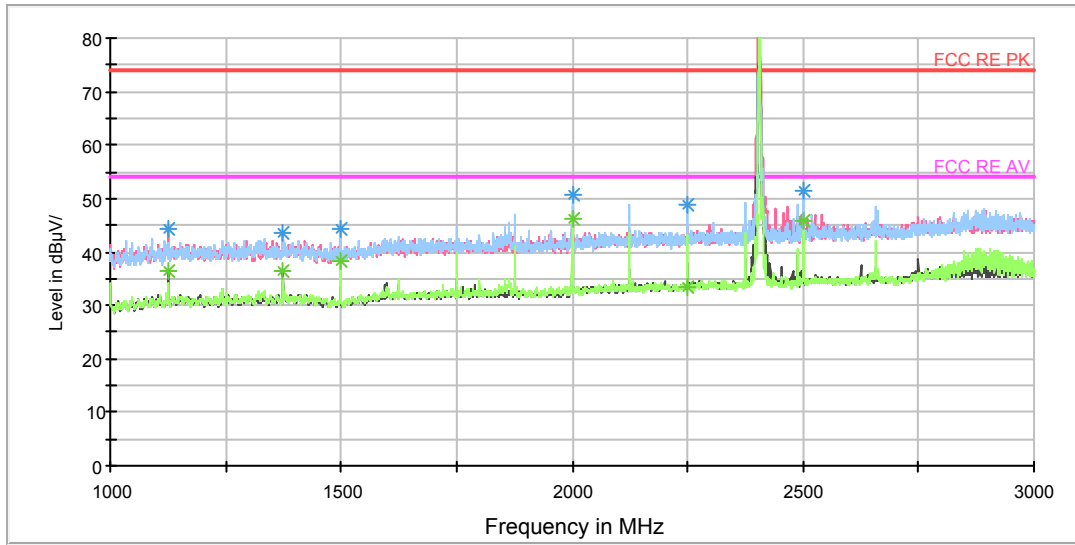

Note: The signal beyond the limit is carrier.
Radiates Emission from 1GHz to 3GHz

Frequency (MHz)	Peak (dBuV/m)	Height (cm)	Polarization	Azimuth (deg)	Reading value (dBuV/m)	Correct Factor (dB)	Margin (dB)	Limit (dBuV/m)
1125.000000	44.3	101.0	V	0.0	45.2	-0.9	29.7	74
1375.000000	43.6	101.0	V	0.0	43.7	0.1	30.4	74
1500.000000	44.4	101.0	H	21.0	44.9	-0.5	29.6	74
2000.000000	50.7	101.0	H	102.0	52.9	2.2	23.3	74
2249.000000	42.6	101.0	V	0.0	46.3	3.7	31.4	74
2500.000000	51.5	101.0	V	358.0	56.5	5.0	22.5	74

Remark: 1. Correction Factor = Antenna factor+ Insertion loss (cable loss + amplifier gain)

Frequency (MHz)	Average (dBuV/m)	Height (cm)	Polarization	Azimuth (deg)	Reading value (dBuV/m)	Correct Factor (dB)	Margin (dB)	Limit (dBuV/m)
1125.000000	36.4	101.0	V	0.0	37.3	-0.9	17.6	54
1375.000000	36.4	101.0	V	0.0	36.5	0.1	17.6	54
1500.000000	38.2	101.0	H	21.0	38.7	-0.5	15.8	54
2000.000000	46.3	101.0	H	102.0	48.5	2.2	7.7	54
2250.000000	43.1	101.0	H	102.0	46.8	3.7	10.9	54
2500.000000	45.8	101.0	V	358.0	50.8	5.0	8.2	54

Remark: 1. Correction Factor = Antenna factor+ Insertion loss (cable loss + amplifier gain)

RE 3G-18GHz PK+AV Class B

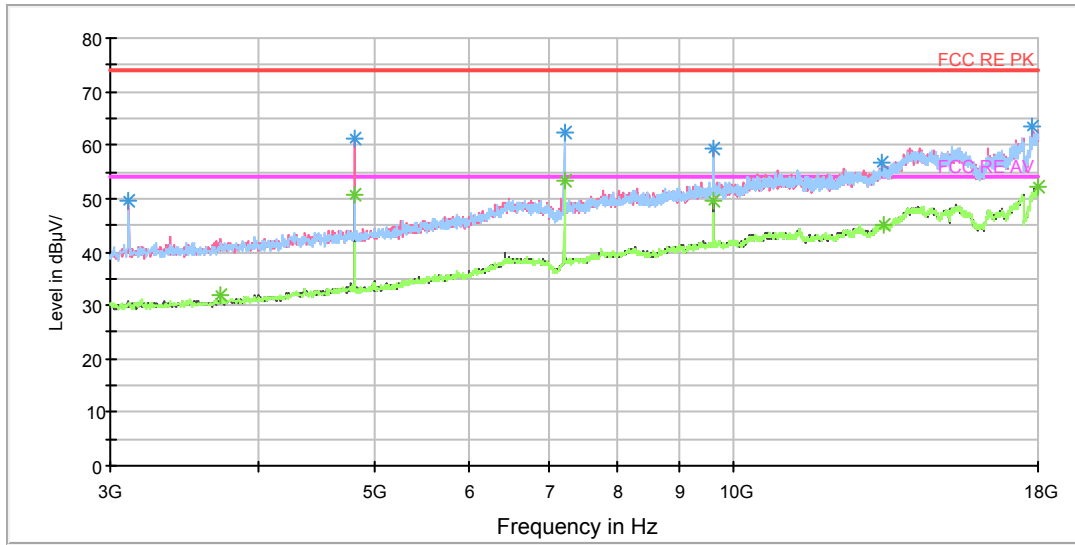

Radiates Emission from 3GHz to 18GHz

Frequency (MHz)	Peak (dBuV/m)	Height (cm)	Polarization	Azimuth (deg)	Reading value (dBuV/m)	Correct Factor (dB)	Margin (dB)	Limit (dBuV/m)
3108.750000	49.6	101.0	V	10.0	53.1	-3.5	24.4	74
4807.500000	61.4	101.0	V	154.0	61.9	-0.5	12.6	74
7215.000000	62.4	101.0	H	134.0	67.9	5.5	11.6	74
9618.750000	59.3	101.0	V	164.0	70.1	10.8	14.7	74
13308.750000	56.5	101.0	H	163.0	74.2	17.7	17.5	74
17823.750000	63.4	101.0	V	351.0	86.9	23.5	10.6	74

Remark: 1. Correction Factor = Antenna factor+ Insertion loss (cable loss + amplifier gain)

Frequency (MHz)	Average (dBuV/m)	Height (cm)	Polarization	Azimuth (deg)	Reading value (dBuV/m)	Correct Factor (dB)	Margin (dB)	Limit (dBuV/m)
3716.250000	31.9	101.0	H	0.0	34.4	-2.5	22.1	54
4807.500000	50.8	101.0	V	154.0	51.3	-0.5	3.2	54
7215.000000	53.2	101.0	H	134.0	58.7	5.5	0.8	54
9622.500000	49.6	101.0	V	164.0	60.4	10.8	4.4	54
13342.500000	45.3	101.0	V	0.0	63.1	17.8	8.7	54
17992.500000	52.2	101.0	H	173.0	78.0	25.8	1.8	54

Remark: 1. Correction Factor = Antenna factor+ Insertion loss (cable loss + amplifier gain)

RE 18-26.5GHz PK+AV

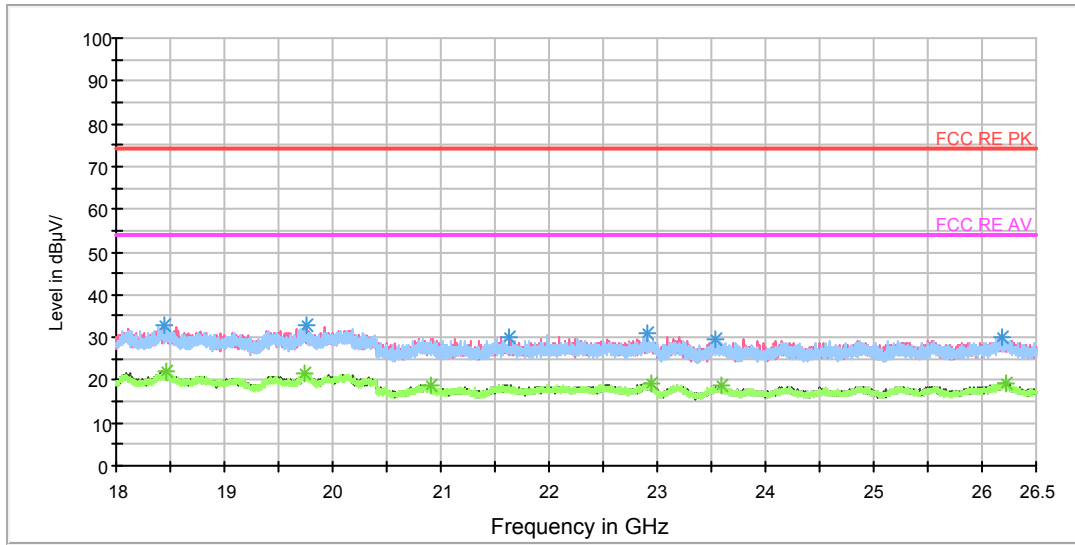

Radiates Emission from 18GHz to 26.5GHz

Frequency (MHz)	Peak (dBuV/m)	Height (cm)	Polarization	Azimuth (deg)	Reading value (dBuV/m)	Correct Factor (dB)	Margin (dB)	Limit (dBuV/m)
18456.875000	30.1	100.0	H	0.0	33.6	-3.5	43.9	74
19745.687500	30.6	100.0	V	0.0	35.3	-4.7	43.4	74
20898.500000	28.2	100.0	V	0.0	33.2	-5.0	45.8	74
22948.062500	28.1	100.0	V	0.0	32.7	-4.6	45.9	74
23588.750000	27.1	100.0	H	0.0	32.4	-5.3	46.9	74
26226.937500	27.7	100.0	V	0.0	32.7	-5.0	46.3	74

Remark: 1. Correction Factor = Antenna factor+ Insertion loss (cable loss + amplifier gain)

Frequency (MHz)	Average (dBuV/m)	Height (cm)	Polarization	Azimuth (deg)	Reading value (dBuV/m)	Correct Factor (dB)	Margin (dB)	Limit (dBuV/m)
18456.875000	22.1	100.0	H	0.0	25.6	-3.5	31.9	54
19745.687500	21.5	100.0	V	0.0	26.2	-4.7	32.5	54
20898.500000	18.9	100.0	V	0.0	23.9	-5.0	35.1	54
22948.062500	19.4	100.0	V	0.0	24.0	-4.6	34.6	54
23588.750000	18.7	100.0	H	0.0	24.0	-5.3	35.3	54
26226.937500	19.4	100.0	V	0.0	24.4	-5.0	34.6	54

Remark: 1. Correction Factor = Antenna factor+ Insertion loss (cable loss + amplifier gain)

Zigbee CH19

RE 0.03-1GHz QP Class B

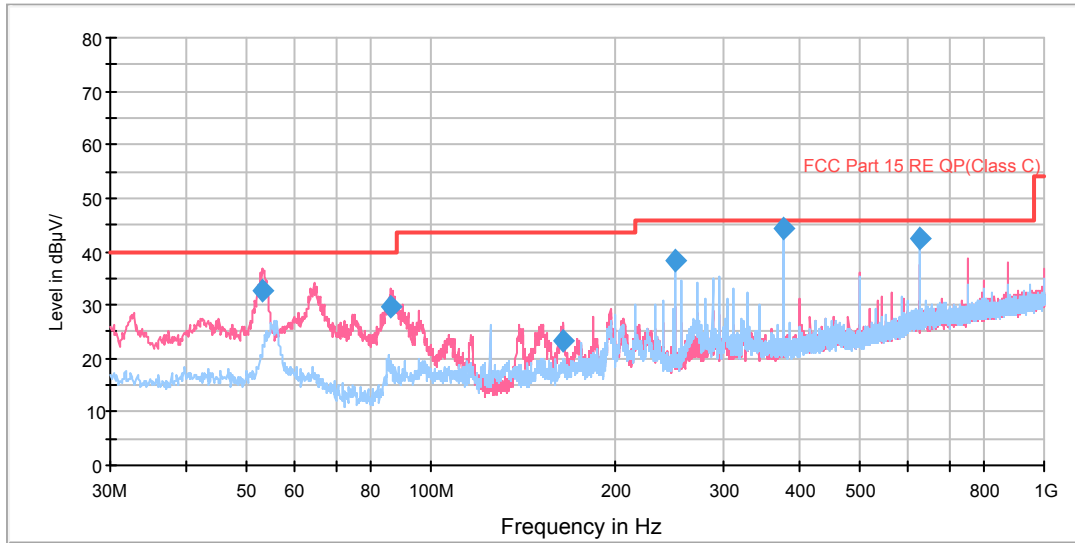

Radiates Emission from 30MHz to 1GHz

Frequency (MHz)	Quasi-Peak (dBuV/m)	Height (cm)	Polarization	Azimuth (deg)	Reading value (dBuV/m)	Correct Factor (dB)	Margin (dB)	Limit (dBuV/m)
53.318750	32.8	101.0	V	314.0	45.6	12.8	7.2	40.0
86.137500	29.6	115.0	V	302.0	40.2	10.6	10.4	40.0
164.220000	23.3	101.0	V	231.0	33.2	9.9	20.2	43.5
249.987500	38.2	101.0	H	18.0	52.3	14.1	7.8	46.0
374.996250	44.3	101.0	H	42.0	61.7	17.4	1.7	46.0
625.015000	42.5	115.0	H	0.0	64.7	22.2	3.5	46.0

- Remark: 1. Quasi-Peak = Reading value + Correction factor
 2. Correction Factor = Antenna factor+ Insertion loss(cable loss+amplifier gain)
 3. Margin = Limit – Quasi-Peak

RE 1G-6GHz PK+AV Class B

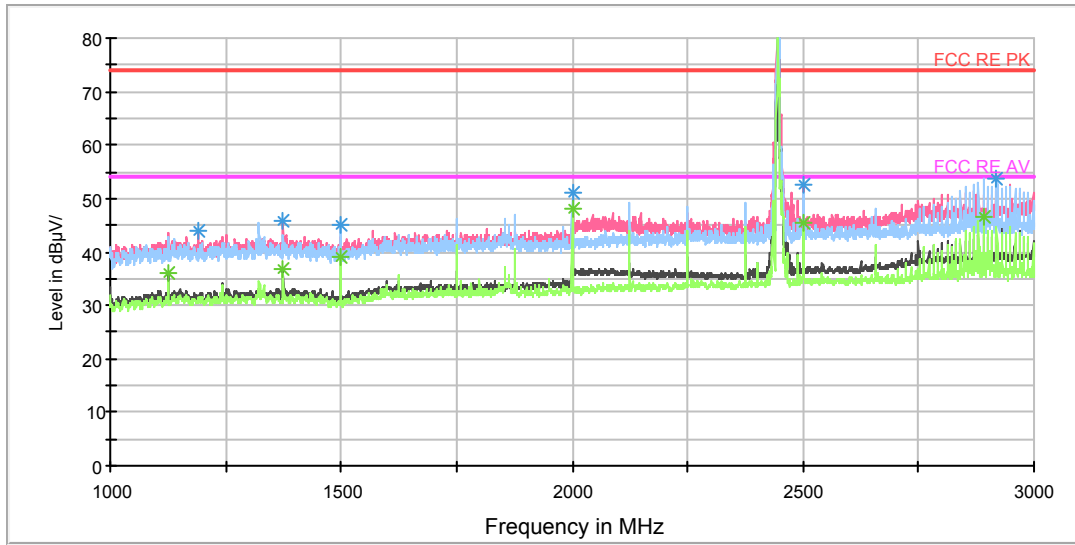

Note: The signal beyond the limit is carrier.

Radiates Emission from 1GHz to 3GHz

Frequency (MHz)	Peak (dBuV/m)	Height (cm)	Polarization	Azimuth (deg)	Reading value (dBuV/m)	Correct Factor (dB)	Margin (dB)	Limit (dBuV/m)
1125.000000	43.7	101.0	V	357.0	44.6	-0.9	30.3	74
1375.000000	45.8	101.0	V	0.0	45.9	0.1	28.2	74
1500.000000	45.2	101.0	H	28.0	45.7	-0.5	28.8	74
2000.000000	51.1	101.0	H	120.0	53.3	2.2	22.9	74
2500.000000	52.7	101.0	V	354.0	57.7	5.0	21.3	74
2890.500000	53.5	101.0	H	312.0	59.3	5.8	20.5	74

Remark: 1. Correction Factor = Antenna factor+ Insertion loss (cable loss + amplifier gain)

Frequency (MHz)	Average (dBuV/m)	Height (cm)	Polarization	Azimuth (deg)	Reading value (dBuV/m)	Correct Factor (dB)	Margin (dB)	Limit (dBuV/m)
1191.500000	31.2	101.0	V	261.0	31.9	-0.7	22.8	54
1375.000000	37.0	101.0	V	0.0	37.1	0.1	17.0	54
1500.000000	39.0	101.0	H	28.0	39.5	-0.5	15.0	54
2000.000000	48.1	101.0	H	120.0	50.3	2.2	5.9	54
2500.000000	45.4	101.0	V	354.0	50.4	5.0	8.6	54
2919.500000	44.8	101.0	H	312.0	50.6	5.8	9.2	54

Remark: 1. Correction Factor = Antenna factor+ Insertion loss (cable loss + amplifier gain)

RE 3G-18GHz PK+AV Class B

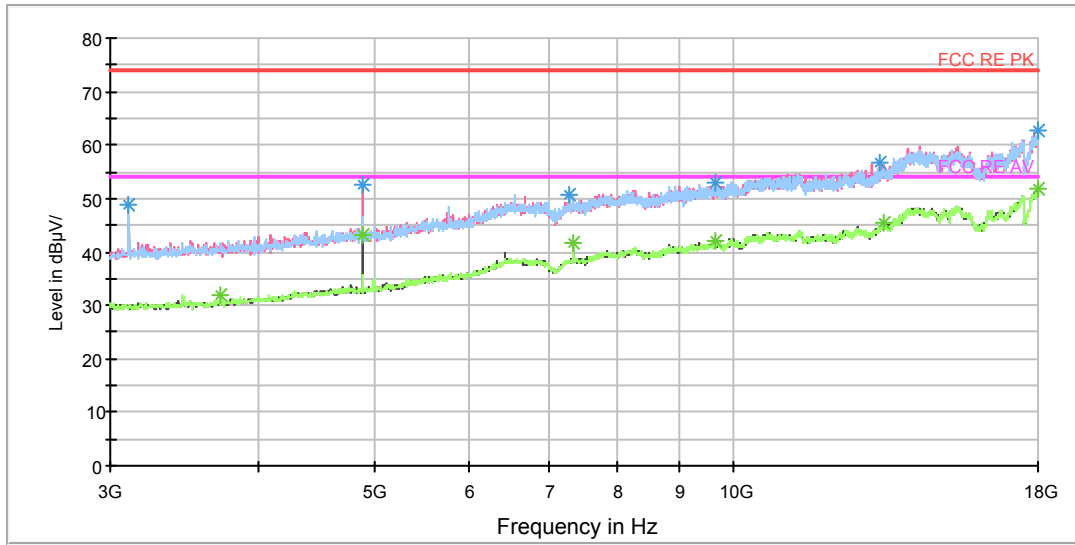

Radiates Emission from 3GHz to 18GHz

Frequency (MHz)	Peak (dBuV/m)	Height (cm)	Polarization	Azimuth (deg)	Reading value (dBuV/m)	Correct Factor (dB)	Margin (dB)	Limit (dBuV/m)
3108.750000	48.7	101.0	H	65.0	52.2	-3.5	25.3	74
4890.000000	52.4	101.0	V	168.0	52.9	-0.5	21.6	74
7290.000000	50.8	101.0	H	251.0	56.4	5.6	23.2	74
9648.750000	53.0	101.0	H	10.0	63.9	10.9	21.0	74
13271.250000	56.8	101.0	H	10.0	74.5	17.7	17.2	74
18000.000000	62.8	101.0	H	172.0	88.7	25.9	11.2	74

Remark: 1. Correction Factor = Antenna factor+ Insertion loss (cable loss + amplifier gain)

Frequency (MHz)	Average (dBuV/m)	Height (cm)	Polarization	Azimuth (deg)	Reading value (dBuV/m)	Correct Factor (dB)	Margin (dB)	Limit (dBuV/m)
3716.250000	32.1	101.0	H	2.0	34.6	-2.5	21.9	54
4890.000000	43.3	101.0	V	168.0	43.8	-0.5	10.7	54
7335.000000	41.8	101.0	H	311.0	47.5	5.7	12.2	54
9648.750000	41.9	101.0	H	10.0	52.8	10.9	12.1	54
13342.500000	45.4	101.0	V	255.0	63.2	17.8	8.6	54
17988.750000	52.0	101.0	V	99.0	77.7	25.7	2.0	54

Remark: 1. Correction Factor = Antenna factor+ Insertion loss (cable loss + amplifier gain)

RE 18-26.5GHz PK+AV

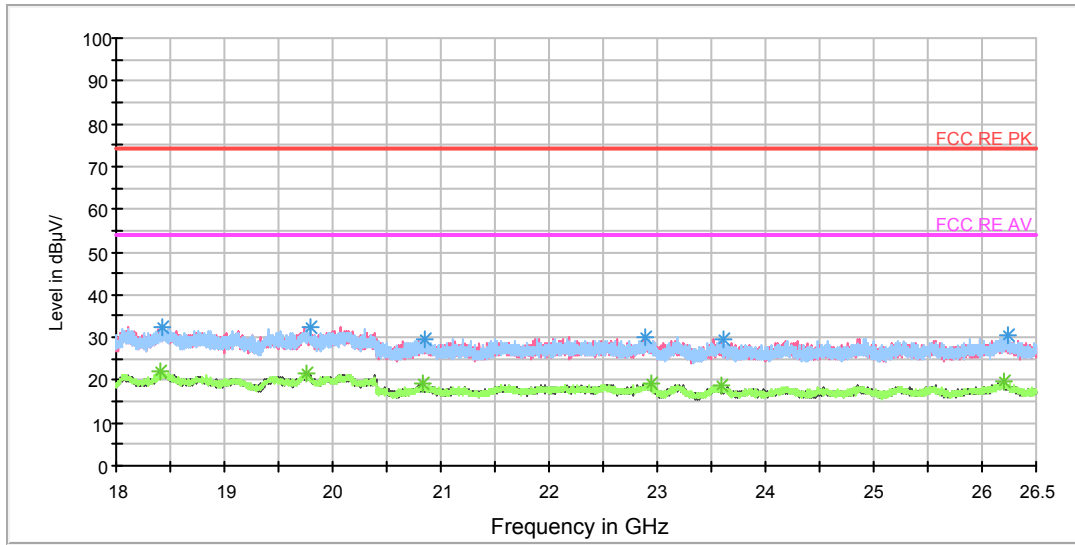

Radiates Emission from 18GHz to 26.5GHz

Frequency (MHz)	Peak (dBuV/m)	Height (cm)	Polarization	Azimuth (deg)	Reading value (dBuV/m)	Correct Factor (dB)	Margin (dB)	Limit (dBuV/m)
18414.375000	30.5	100.0	H	0.0	34.0	-3.5	43.5	74
19751.000000	29.2	100.0	V	0.0	33.9	-4.7	44.8	74
20833.687500	27.2	100.0	V	0.0	32.1	-4.9	46.8	74
22941.687500	28.3	100.0	V	0.0	32.9	-4.6	45.7	74
23597.250000	28.2	100.0	H	0.0	33.5	-5.3	45.8	74
26199.312500	28.7	100.0	V	0.0	33.8	-5.1	45.3	74

Remark: 1. Correction Factor = Antenna factor+ Insertion loss (cable loss + amplifier gain)

Frequency (MHz)	Average (dBuV/m)	Height (cm)	Polarization	Azimuth (deg)	Reading value (dBuV/m)	Correct Factor (dB)	Margin (dB)	Limit (dBuV/m)
18414.375000	21.9	100.0	H	0.0	25.4	-3.5	32.1	54
19751.000000	21.8	100.0	V	0.0	26.5	-4.7	32.2	54
20833.687500	19.3	100.0	V	0.0	24.2	-4.9	34.7	54
22941.687500	19.0	100.0	V	0.0	23.6	-4.6	35.0	54
23597.250000	18.6	100.0	H	0.0	23.9	-5.3	35.4	54
26199.312500	19.5	100.0	V	0.0	24.6	-5.1	34.5	54

Remark: 1. Correction Factor = Antenna factor+ Insertion loss (cable loss + amplifier gain)

Zigbee CH25

RE 0.03-1GHz QP Class B

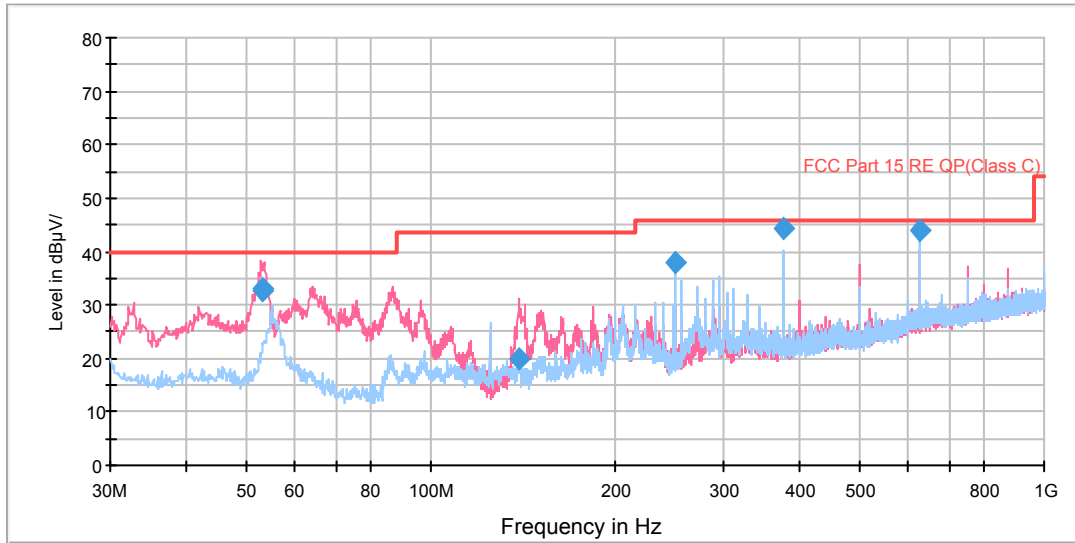

Radiates Emission from 30MHz to 1GHz

Frequency (MHz)	Quasi-Peak (dBuV/m)	Height (cm)	Polarization	Azimuth (deg)	Reading value (dBuV/m)	Correct Factor (dB)	Margin (dB)	Limit (dBuV/m)
53.276250	32.8	101.0	V	344.0	45.6	12.8	7.2	40.0
53.326250	33.1	101.0	V	22.0	45.9	12.8	6.9	40.0
139.530000	20.0	101.0	V	0.0	28.9	8.9	23.5	43.5
249.987500	38.1	101.0	H	20.0	52.2	14.1	7.9	46.0
374.996250	44.4	101.0	H	22.0	61.8	17.4	1.6	46.0
625.015000	44.1	115.0	H	352.0	66.3	22.2	1.9	46.0

- Remark:**
1. Quasi-Peak = Reading value + Correction factor
 2. Correction Factor = Antenna factor+ Insertion loss(cable loss+amplifier gain)
 3. Margin = Limit – Quasi-Peak

RE 1G-6GHz PK+AV Class B

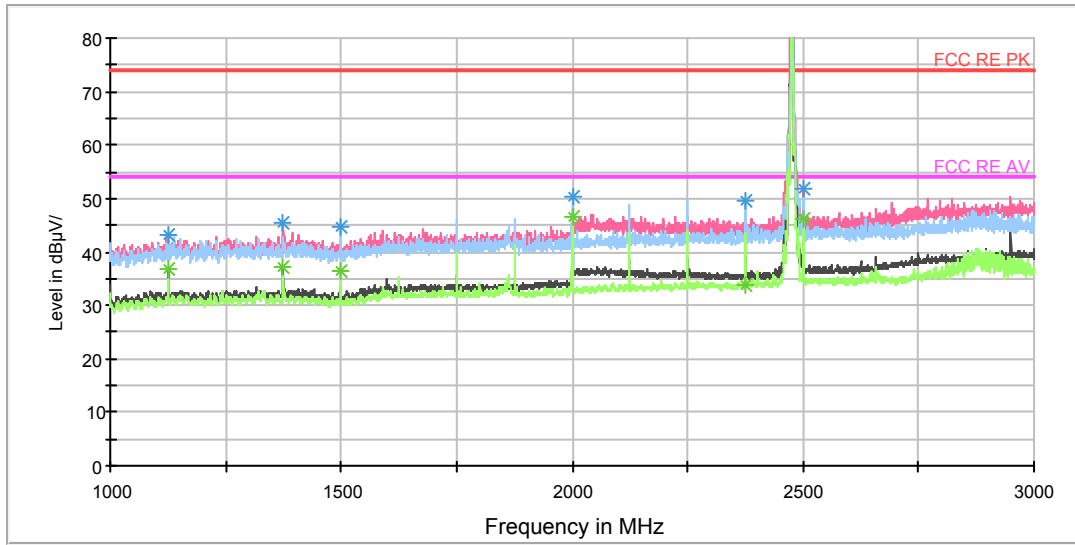

Note: The signal beyond the limit is carrier.

Radiates Emission from 1GHz to 3GHz

Frequency (MHz)	Peak (dBuV/m)	Height (cm)	Polarization	Azimuth (deg)	Reading value (dBuV/m)	Correct Factor (dB)	Margin (dB)	Limit (dBuV/m)
1125.000000	43.1	101.0	V	0.0	44.0	-0.9	30.9	74
1375.000000	45.5	101.0	V	354.0	45.6	0.1	28.5	74
1500.000000	44.8	101.0	H	15.0	45.3	-0.5	29.2	74
2000.000000	50.3	101.0	H	101.0	52.5	2.2	23.7	74
2375.000000	49.6	101.0	H	118.0	53.9	4.3	24.4	74
2500.000000	51.8	101.0	V	354.0	56.8	5.0	22.2	74

Remark: 1. Correction Factor = Antenna factor+ Insertion loss (cable loss + amplifier gain)

Frequency (MHz)	Average (dBuV/m)	Height (cm)	Polarization	Azimuth (deg)	Reading value (dBuV/m)	Correct Factor (dB)	Margin (dB)	Limit (dBuV/m)
1125.000000	36.7	101.0	V	0.0	37.6	-0.9	17.3	54
1375.000000	37.2	101.0	V	354.0	37.3	0.1	16.8	54
1500.000000	36.6	101.0	H	15.0	37.1	-0.5	17.4	54
2000.000000	46.7	101.0	H	101.0	48.9	2.2	7.3	54
2376.500000	33.7	101.0	H	0.0	38.0	4.3	20.3	54
2500.000000	46.2	101.0	V	354.0	51.2	5.0	7.8	54

Remark: 1. Correction Factor = Antenna factor+ Insertion loss (cable loss + amplifier gain)

RE 3G-18GHz PK+AV Class B

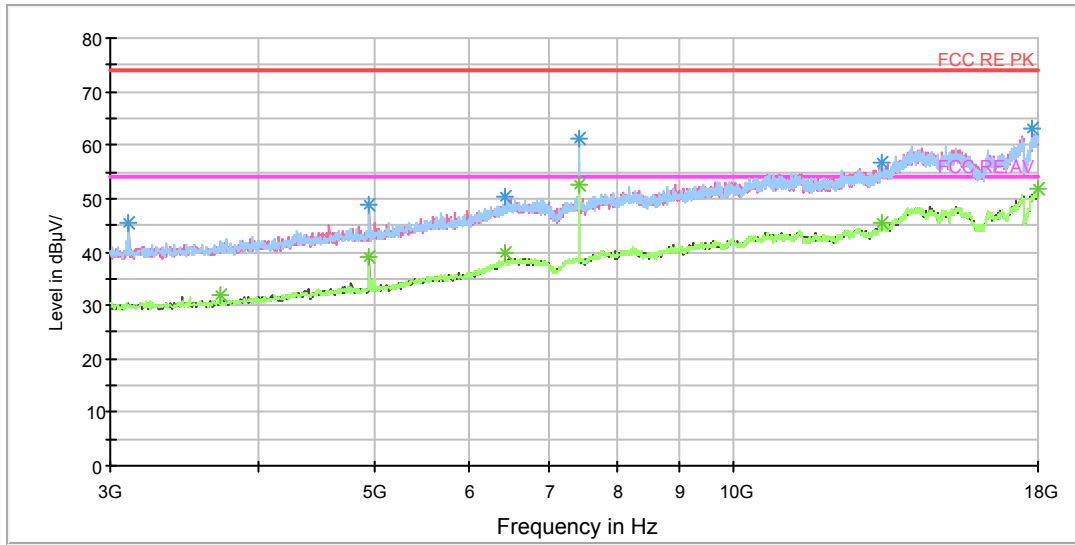

Radiates Emission from 3GHz to 18GHz

Frequency (MHz)	Peak (dBuV/m)	Height (cm)	Polarization	Azimuth (deg)	Reading value (dBuV/m)	Correct Factor (dB)	Margin (dB)	Limit (dBuV/m)
3108.750000	45.5	101.0	V	6.0	49.0	-3.5	28.5	74
4950.000000	48.8	101.0	V	294.0	49.2	-0.4	25.2	74
6431.250000	50.3	101.0	V	356.0	55.4	5.1	23.7	74
7425.000000	61.1	101.0	H	240.0	67.0	5.9	12.9	74
13293.750000	56.6	101.0	H	1.0	74.3	17.7	17.4	74
17820.000000	63.1	101.0	H	0.0	86.6	23.5	10.9	74

Remark: 1. Correction Factor = Antenna factor+ Insertion loss (cable loss + amplifier gain)

Frequency (MHz)	Average (dBuV/m)	Height (cm)	Polarization	Azimuth (deg)	Reading value (dBuV/m)	Correct Factor (dB)	Margin (dB)	Limit (dBuV/m)
3716.250000	32.0	101.0	H	0.0	34.5	-2.5	22.0	54
4950.000000	39.1	101.0	V	294.0	39.5	-0.4	14.9	54
6431.250000	39.7	101.0	V	356.0	44.8	5.1	14.3	54
7425.000000	52.5	101.0	H	240.0	58.4	5.9	1.5	54
13316.250000	45.3	101.0	H	6.0	63.0	17.7	8.7	54
17992.500000	52.0	101.0	H	300.0	77.8	25.8	2.0	54

Remark: 1. Correction Factor = Antenna factor+ Insertion loss (cable loss + amplifier gain)



RE 18-26.5GHz PK+AV

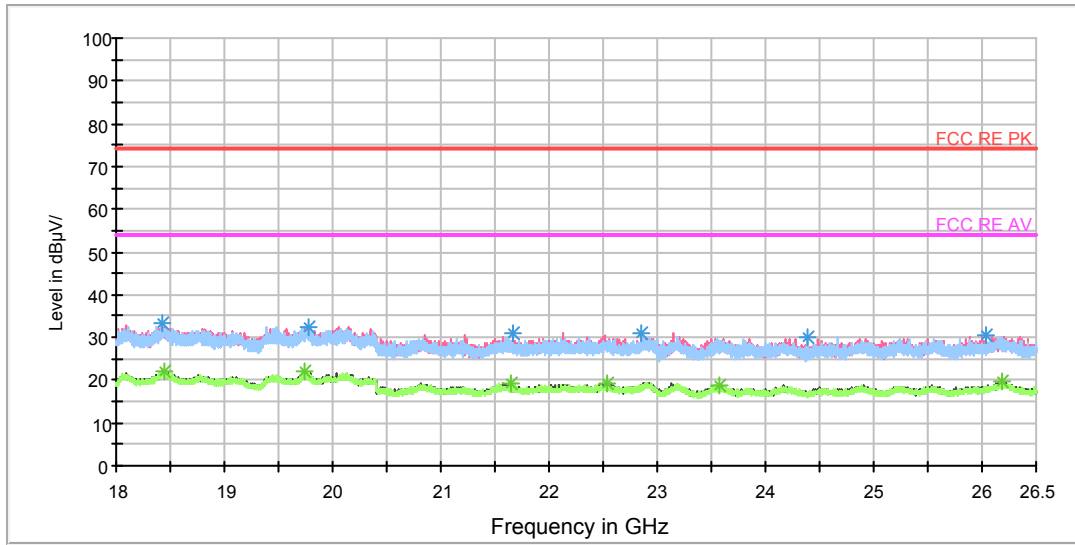

Radiates Emission from 18GHz to 26.5GHz

Frequency (MHz)	Peak (dBuV/m)	Height (cm)	Polarization	Azimuth (deg)	Reading value (dBuV/m)	Correct Factor (dB)	Margin (dB)	Limit (dBuV/m)
18453.687500	31.1	100.0	V	0.0	34.6	-3.5	42.9	74
19745.687500	31.2	100.0	V	0.0	35.9	-4.7	42.8	74
21644.375000	28.7	100.0	V	0.0	33.9	-5.2	45.3	74
22545.375000	27.5	100.0	V	0.0	31.9	-4.4	46.5	74
23581.312500	26.7	100.0	H	0.0	32.0	-5.3	47.3	74
26179.125000	30.3	100.0	H	0.0	35.4	-5.1	43.7	74

Remark: 1. Correction Factor = Antenna factor+ Insertion loss (cable loss + amplifier gain)

Frequency (MHz)	Average (dBuV/m)	Height (cm)	Polarization	Azimuth (deg)	Reading value (dBuV/m)	Correct Factor (dB)	Margin (dB)	Limit (dBuV/m)
18453.687500	22.1	100.0	V	0.0	25.6	-3.5	31.9	54
19745.687500	22.1	100.0	V	0.0	26.8	-4.7	31.9	54
21644.375000	19.4	100.0	V	0.0	24.6	-5.2	34.6	54
22545.375000	19.4	100.0	V	0.0	23.8	-4.4	34.6	54
23581.312500	18.8	100.0	H	0.0	24.1	-5.3	35.2	54
26179.125000	19.7	100.0	H	0.0	24.8	-5.1	34.3	54

Remark: 1. Correction Factor = Antenna factor+ Insertion loss (cable loss + amplifier gain)

5.8. Conducted Emission

Ambient condition

Temperature	Relative humidity	Pressure
23°C ~25°C	45%~50%	101.5kPa

Methods of Measurement

The EUT is placed on a non-metallic table of 80cm height above the horizontal metal reference ground plane. During the test, the EUT was operating in its typical mode. The test method is according to ANSI C63.10-2013. Connect the AC power line of the EUT to the L.I.S.N. Use EMI receiver to detect the average and Quasi-peak value. RBW is set to 9 kHz, VBW is set to 30kHz. The measurement result should include both L line and N line.

The test is in transmitting mode.

Test Setup

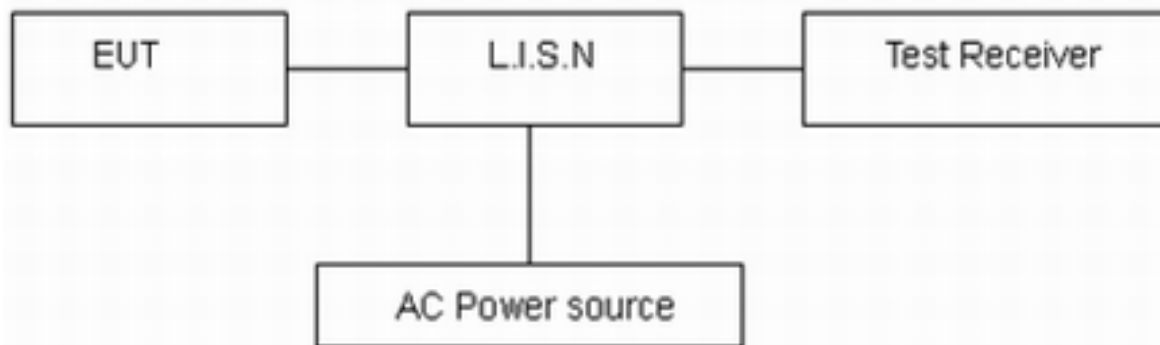

Note: AC Power source is used to change the voltage 110V/60Hz.

Limits

Frequency (MHz)	Conducted Limits(dBμV)	
	Quasi-peak	Average
0.15 - 0.5	66 to 56 *	56 to 46*
0.5 - 5	56	46
5 - 30	60	50

*: Decreases with the logarithm of the frequency.

Measurement Uncertainty

The assessed measurement uncertainty to ensure 95% confidence level for the normal distribution is with the coverage factor $k = 1.96$, $U = 2.69$ dB.



Test Results:

Following plots, Blue trace uses the peak detection, Green trace uses the average detection.

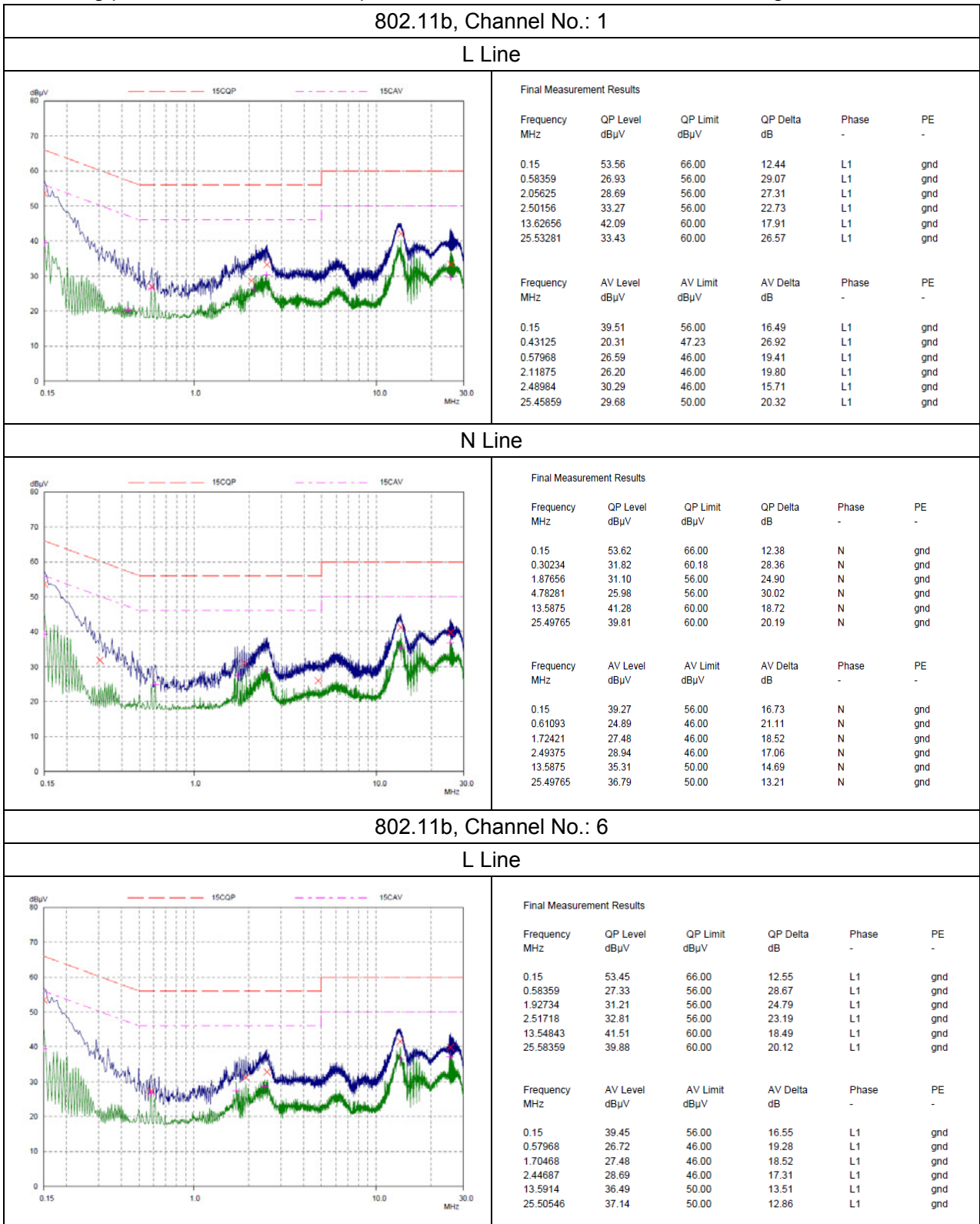



N Line

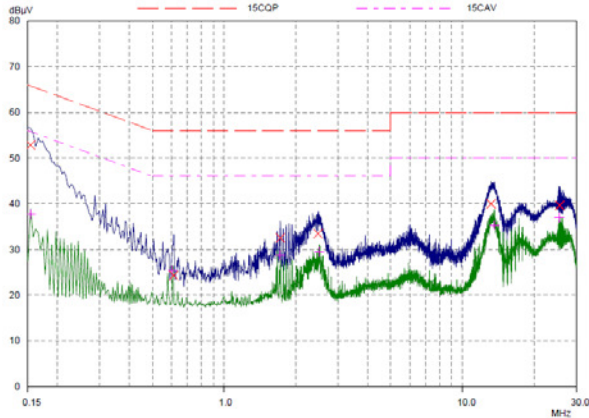

Final Measurement Results

Frequency MHz	QP Level dBuV	QP Limit dBuV	QP Delta dB	Phase	PE
0.1539	52.84	65.79	12.95	N	gnd
0.61484	24.33	56.00	31.67	N	gnd
1.72031	32.52	56.00	23.48	N	gnd
2.47421	33.43	56.00	22.57	N	gnd
13.17734	39.98	60.00	20.02	N	gnd
25.57578	39.64	60.00	20.36	N	gnd

Frequency MHz	AV Level dBuV	AV Limit dBuV	AV Delta dB	Phase	PE
0.1539	37.67	55.79	18.12	N	gnd
0.60703	25.35	46.00	20.65	N	gnd
1.72031	28.76	46.00	17.24	N	gnd
2.50546	29.51	46.00	16.49	N	gnd
13.62656	35.37	50.00	14.63	N	gnd
25.49765	37.01	50.00	12.99	N	gnd

802.11b, Channel No.: 11

L Line

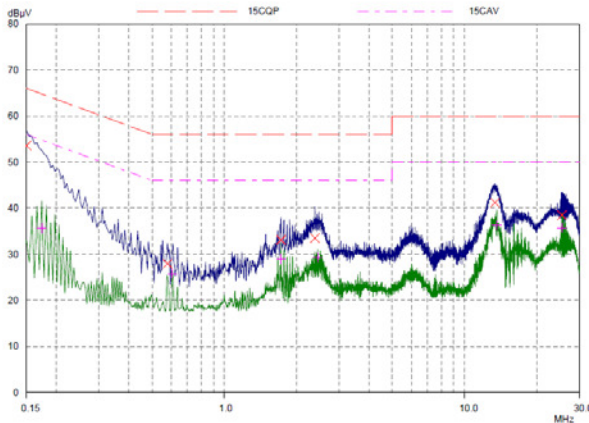

Final Measurement Results

Frequency MHz	QP Level dBuV	QP Limit dBuV	QP Delta dB	Phase	PE
0.15	53.60	66.00	12.40	L1	gnd
0.57968	27.93	56.00	28.07	L1	gnd
1.72031	33.10	56.00	22.90	L1	gnd
2.38046	33.49	56.00	22.51	L1	gnd
13.39218	41.19	60.00	18.81	L1	gnd
25.43125	38.47	60.00	21.53	L1	gnd

Frequency MHz	AV Level dBuV	AV Limit dBuV	AV Delta dB	Phase	PE
0.17343	35.62	54.79	19.17	L1	gnd
0.60703	25.78	46.00	20.22	L1	gnd
1.72031	28.96	46.00	17.04	L1	gnd
2.44296	29.32	46.00	16.68	L1	gnd
13.62656	36.24	50.00	13.76	L1	gnd
25.43125	35.71	50.00	14.29	L1	gnd

N Line

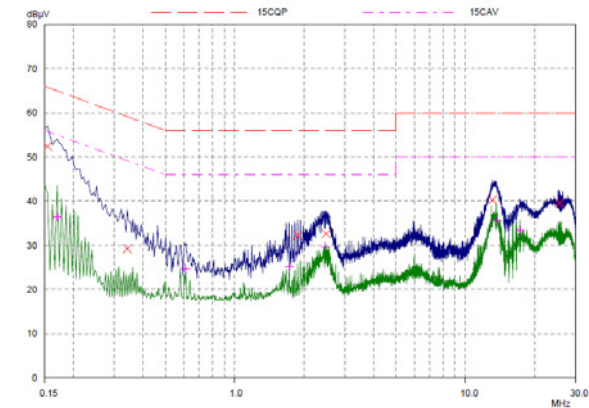

Final Measurement Results

Frequency MHz	QP Level dBuV	QP Limit dBuV	QP Delta dB	Phase	PE
0.1539	52.42	65.79	13.37	N	gnd
0.3414	29.22	59.17	29.95	N	gnd
1.87265	32.22	56.00	23.78	N	gnd
2.48593	32.65	56.00	23.35	N	gnd
13.09921	40.27	60.00	19.73	N	gnd
25.57578	39.54	60.00	20.46	N	gnd

Frequency MHz	AV Level dBuV	AV Limit dBuV	AV Delta dB	Phase	PE
0.16953	36.40	54.98	18.58	N	gnd
0.61093	24.66	46.00	21.34	N	gnd
1.72421	25.19	46.00	20.81	N	gnd
2.47421	29.73	46.00	16.27	N	gnd
13.59531	35.55	50.00	14.45	N	gnd
17.27109	33.33	50.00	16.67	N	gnd



802.11g, Channel No.: 1

L Line

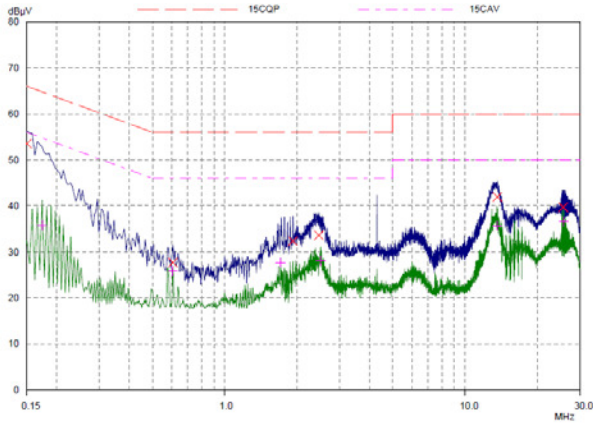

Final Measurement Results

Frequency MHz	QP Level dBµV	QP Limit dBµV	QP Delta dB	Phase	PE
0.15	53.56	66.00	12.44	L1	gnd
0.60703	27.70	56.00	28.30	L1	gnd
1.91953	32.37	56.00	23.63	L1	gnd
2.45859	33.61	56.00	22.39	L1	gnd
13.62656	41.95	60.00	18.05	L1	gnd
25.58359	39.72	60.00	20.28	L1	gnd

Frequency MHz	AV Level dBµV	AV Limit dBµV	AV Delta dB	Phase	PE
0.17343	35.80	54.79	18.99	L1	gnd
0.60703	25.85	46.00	20.15	L1	gnd
1.70468	27.65	46.00	18.35	L1	gnd
2.50156	28.12	46.00	17.88	L1	gnd
13.56015	35.73	50.00	14.27	L1	gnd
25.73984	36.57	50.00	13.43	L1	gnd

N Line

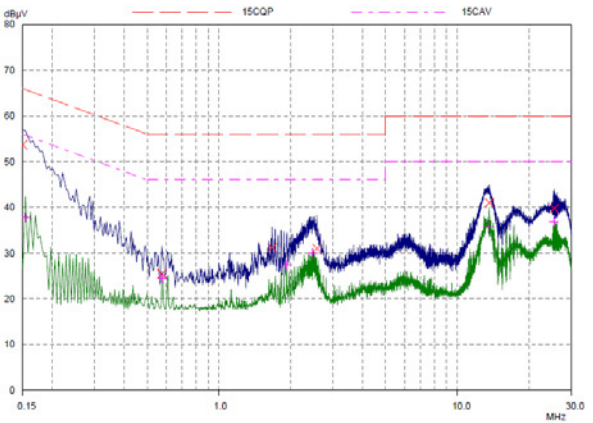

Final Measurement Results

Frequency MHz	QP Level dBµV	QP Limit dBµV	QP Delta dB	Phase	PE
0.15	53.68	66.00	12.32	N	gnd
0.57578	25.45	56.00	30.55	N	gnd
1.66953	31.17	56.00	24.83	N	gnd
2.57187	31.01	56.00	24.99	N	gnd
13.61484	41.06	60.00	18.94	N	gnd
25.49765	39.77	60.00	20.23	N	gnd

Frequency MHz	AV Level dBµV	AV Limit dBµV	AV Delta dB	Phase	PE
0.1539	37.82	55.79	17.97	N	gnd
0.57968	24.51	46.00	21.49	N	gnd
1.92343	27.46	46.00	18.54	N	gnd
2.47421	29.95	46.00	16.05	N	gnd
13.5914	35.83	50.00	14.17	N	gnd
25.41953	36.91	50.00	13.09	N	gnd

802.11g, Channel No.: 6

L Line

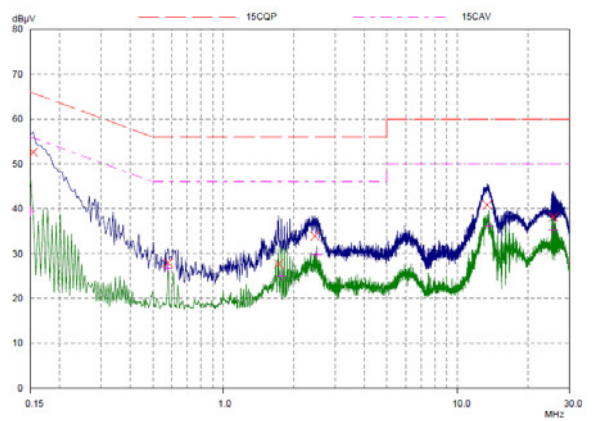

Final Measurement Results

Frequency MHz	QP Level dBµV	QP Limit dBµV	QP Delta dB	Phase	PE
0.1539	52.56	65.79	13.23	L1	gnd
0.57968	27.95	56.00	28.05	L1	gnd
1.72031	27.75	56.00	28.25	L1	gnd
2.45859	33.87	56.00	22.13	L1	gnd
13.37656	40.85	60.00	19.15	L1	gnd
25.66171	38.10	60.00	21.90	L1	gnd

Frequency MHz	AV Level dBµV	AV Limit dBµV	AV Delta dB	Phase	PE
0.15	39.39	56.00	16.61	L1	gnd
0.57968	26.72	46.00	19.28	L1	gnd
1.76718	24.96	46.00	21.04	L1	gnd
2.50546	29.86	46.00	16.14	L1	gnd
13.59531	36.15	50.00	13.85	L1	gnd
25.65781	35.37	50.00	14.63	L1	gnd



N Line

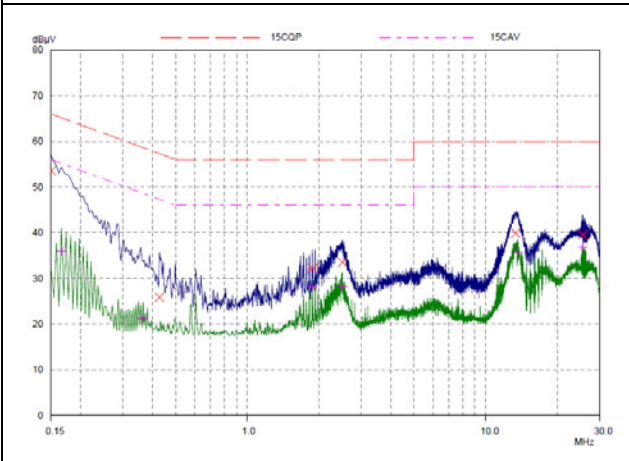

Final Measurement Results

Frequency MHz	QP Level dBuV	QP Limit dBuV	QP Delta dB	Phase -	PE -
0.15	53.52	66.00	12.48	N	gnd
0.42734	25.85	57.30	31.45	N	gnd
1.87265	32.26	56.00	23.74	N	gnd
2.50156	33.51	56.00	22.49	N	gnd
13.3414	39.93	60.00	20.07	N	gnd
25.57578	39.52	60.00	20.48	N	gnd

Frequency MHz	AV Level dBuV	AV Limit dBuV	AV Delta dB	Phase -	PE -
0.16562	35.94	55.18	19.24	N	gnd
0.36484	21.31	48.62	27.31	N	gnd
1.87265	28.26	46.00	17.74	N	gnd
2.50156	28.23	46.00	17.77	N	gnd
13.62656	35.89	50.00	14.11	N	gnd
25.49765	36.79	50.00	13.21	N	gnd

802.11g, Channel No.: 11

L Line

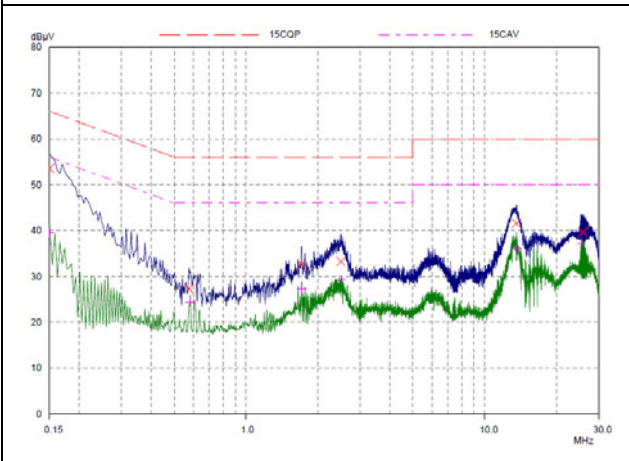

Final Measurement Results

Frequency MHz	QP Level dBuV	QP Limit dBuV	QP Delta dB	Phase -	PE -
0.15	53.54	66.00	12.46	L1	gnd
0.57578	27.29	56.00	28.71	L1	gnd
1.70468	32.62	56.00	23.38	L1	gnd
2.49375	33.25	56.00	22.75	L1	gnd
13.55234	41.57	60.00	18.43	L1	gnd
25.73593	39.59	60.00	20.41	L1	gnd

Frequency MHz	AV Level dBuV	AV Limit dBuV	AV Delta dB	Phase -	PE -
0.15	39.51	56.00	16.49	L1	gnd
0.58359	24.43	46.00	21.57	L1	gnd
1.70859	27.19	46.00	18.81	L1	gnd
2.50546	29.27	46.00	16.73	L1	gnd
13.5875	36.10	50.00	13.90	L1	gnd
25.42343	37.13	50.00	12.87	L1	gnd

N Line

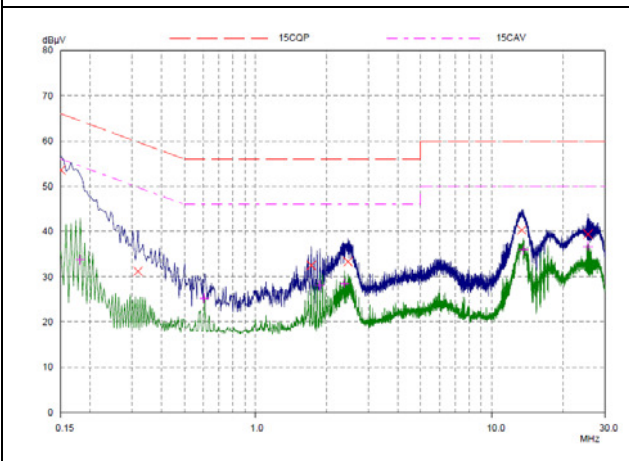

Final Measurement Results

Frequency MHz	QP Level dBuV	QP Limit dBuV	QP Delta dB	Phase -	PE -
0.15	53.58	66.00	12.42	N	gnd
0.31796	31.18	59.76	28.58	N	gnd
1.72031	32.50	56.00	23.50	N	gnd
2.45859	33.29	56.00	22.71	N	gnd
13.36093	40.27	60.00	19.73	N	gnd
25.50156	39.37	60.00	20.63	N	gnd

Frequency MHz	AV Level dBuV	AV Limit dBuV	AV Delta dB	Phase -	PE -
0.18125	33.73	54.43	20.70	N	gnd
0.60703	25.27	46.00	20.73	N	gnd
1.87265	28.10	46.00	17.90	N	gnd
2.38046	28.54	46.00	17.46	N	gnd
13.5914	35.92	50.00	14.08	N	gnd
25.49765	36.74	50.00	13.26	N	gnd



802.11n(HT20), Channel No.: 1

L Line

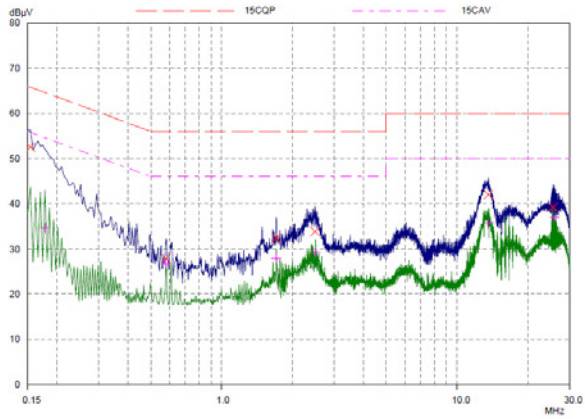

Final Measurement Results

Frequency MHz	QP Level dBµV	QP Limit dBµV	QP Delta dB	Phase	PE
0.1539	52.52	65.79	13.27	L1	gnd
0.57968	27.87	56.00	28.13	L1	gnd
1.70468	32.37	56.00	23.63	L1	gnd
2.48984	33.83	56.00	22.17	L1	gnd
13.5875	42.02	60.00	17.98	L1	gnd
25.58359	39.20	60.00	20.80	L1	gnd

Frequency MHz	AV Level dBµV	AV Limit dBµV	AV Delta dB	Phase	PE
0.17734	34.60	54.61	20.01	L1	gnd
0.57968	26.72	46.00	19.28	L1	gnd
1.70468	27.98	46.00	18.02	L1	gnd
2.50546	29.27	46.00	16.73	L1	gnd
13.64609	35.75	50.00	14.25	L1	gnd
25.89218	37.01	50.00	12.99	L1	gnd

N Line

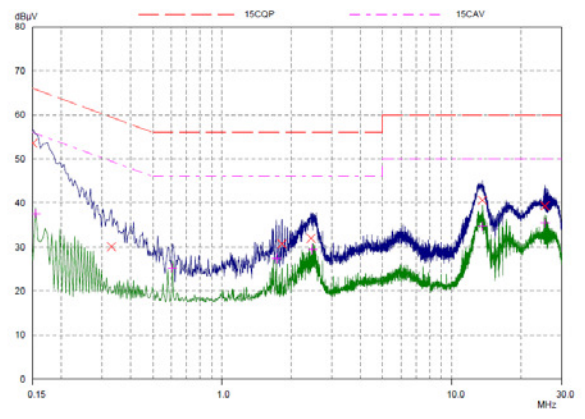

Final Measurement Results

Frequency MHz	QP Level dBµV	QP Limit dBµV	QP Delta dB	Phase	PE
0.15	53.56	66.00	12.44	N	gnd
0.32968	30.07	59.46	29.39	N	gnd
1.82187	30.75	56.00	25.25	N	gnd
2.43906	31.98	56.00	24.02	N	gnd
13.58359	40.63	60.00	19.37	N	gnd
25.42343	39.32	60.00	20.68	N	gnd

Frequency MHz	AV Level dBµV	AV Limit dBµV	AV Delta dB	Phase	PE
0.1539	37.60	55.79	18.19	N	gnd
0.60703	25.27	46.00	20.73	N	gnd
1.72421	27.42	46.00	18.58	N	gnd
2.47421	29.46	46.00	16.54	N	gnd
13.59921	34.70	50.00	15.30	N	gnd
25.49765	35.40	50.00	14.60	N	gnd

802.11n(HT20), Channel No.: 6

L Line

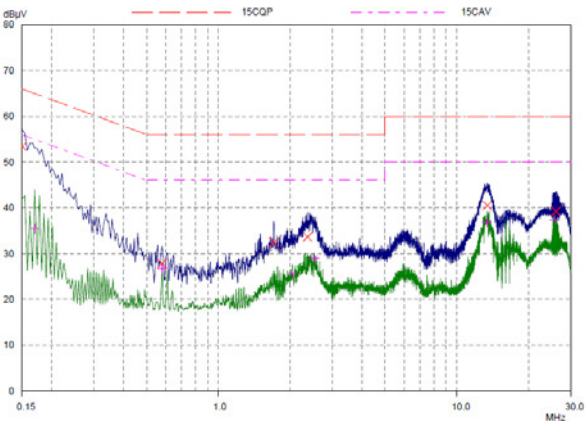

Final Measurement Results

Frequency MHz	QP Level dBµV	QP Limit dBµV	QP Delta dB	Phase	PE
0.15	53.45	66.00	12.55	L1	gnd
0.57968	27.85	56.00	28.15	L1	gnd
1.70468	32.44	56.00	23.56	L1	gnd
2.36484	33.63	56.00	22.37	L1	gnd
13.41171	40.52	60.00	19.48	L1	gnd
26.04843	39.27	60.00	20.73	L1	gnd

Frequency MHz	AV Level dBµV	AV Limit dBµV	AV Delta dB	Phase	PE
0.16953	35.43	54.98	19.55	L1	gnd
0.57968	26.72	46.00	19.28	L1	gnd
2.04453	25.65	46.00	20.35	L1	gnd
2.52109	28.99	46.00	17.01	L1	gnd
13.36093	36.81	50.00	13.19	L1	gnd
25.65781	37.42	50.00	12.58	L1	gnd

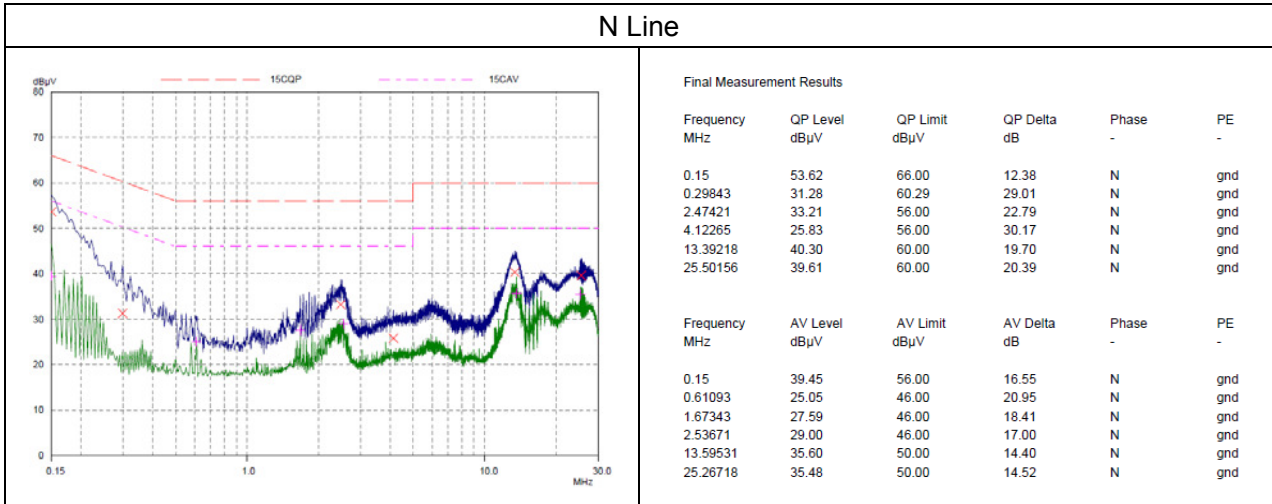

802.11n(HT20), Channel No.: 11

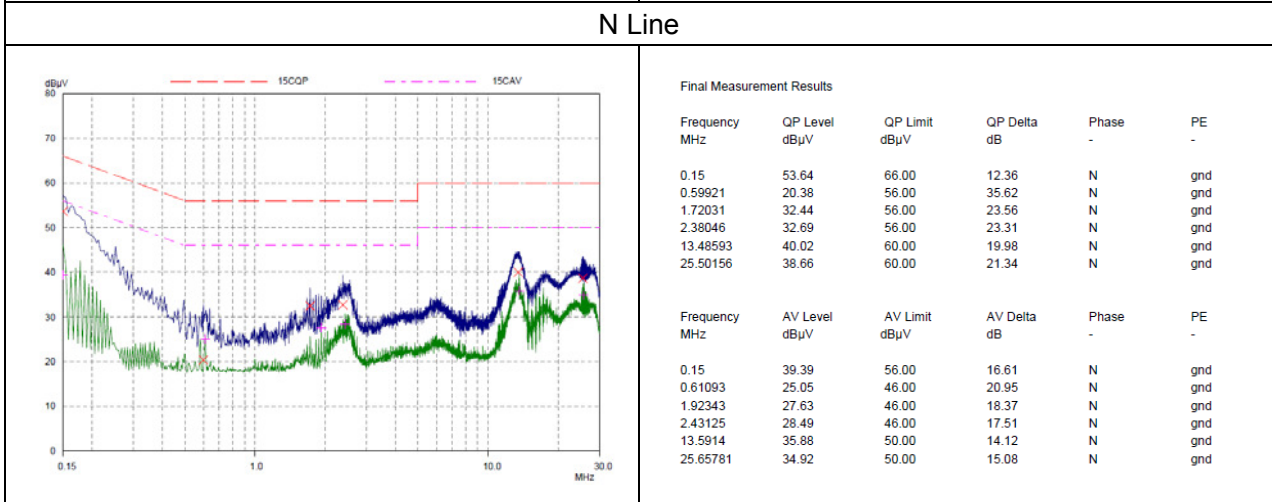
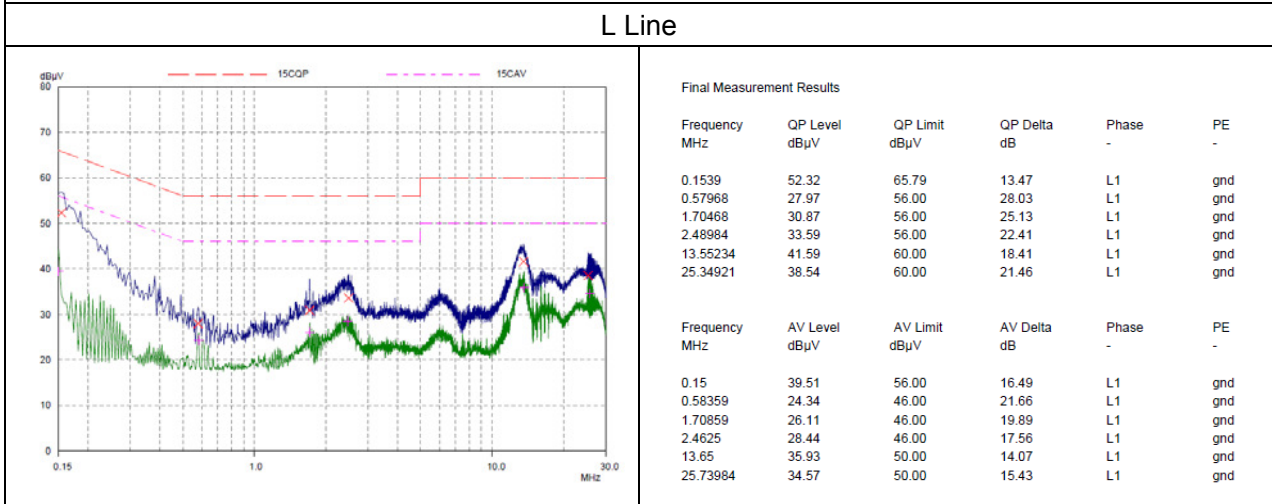



802.11n(HT40), Channel No.: 3

L Line

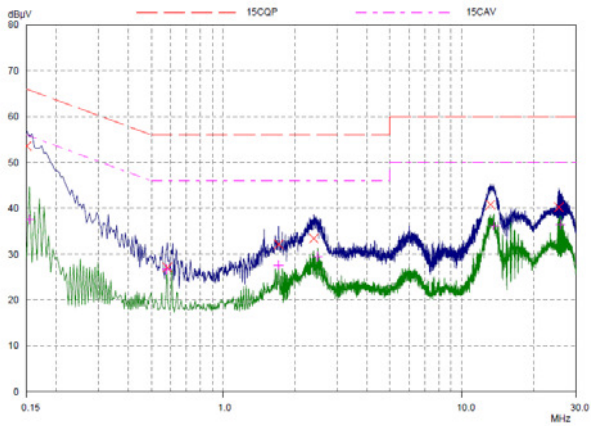

Final Measurement Results

Frequency MHz	QP Level dBuV	QP Limit dBuV	QP Delta dB	Phase	PE
0.15	53.60	66.00	12.40	L1	gnd
0.58359	27.09	56.00	28.91	L1	gnd
1.70468	32.15	56.00	23.85	L1	gnd
2.39609	33.43	56.00	22.57	L1	gnd
13.16953	40.80	60.00	19.20	L1	gnd
25.50156	40.23	60.00	19.77	L1	gnd

Frequency MHz	AV Level dBuV	AV Limit dBuV	AV Delta dB	Phase	PE
0.1539	37.60	55.79	18.19	L1	gnd
0.57968	26.72	46.00	19.28	L1	gnd
1.70468	27.65	46.00	18.35	L1	gnd
2.48984	29.46	46.00	16.54	L1	gnd
13.59531	36.19	50.00	13.81	L1	gnd
25.81796	36.49	50.00	13.51	L1	gnd

N Line

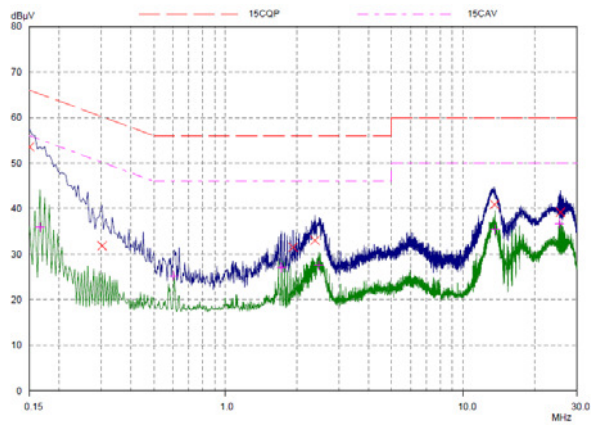

Final Measurement Results

Frequency MHz	QP Level dBuV	QP Limit dBuV	QP Delta dB	Phase	PE
0.15	53.56	66.00	12.44	N	gnd
0.30234	31.82	60.18	28.36	N	gnd
1.92343	31.53	56.00	24.47	N	gnd
2.38046	33.05	56.00	22.95	N	gnd
13.55234	40.90	60.00	19.10	N	gnd
25.66171	39.21	60.00	20.79	N	gnd

Frequency MHz	AV Level dBuV	AV Limit dBuV	AV Delta dB	Phase	PE
0.16562	35.94	55.18	19.24	N	gnd
0.60703	25.27	46.00	20.73	N	gnd
1.72031	27.07	46.00	18.93	N	gnd
2.47031	27.57	46.00	18.43	N	gnd
13.62265	35.46	50.00	14.54	N	gnd
25.42734	36.73	50.00	13.27	N	gnd

802.11n(HT40), Channel No.: 6

L Line

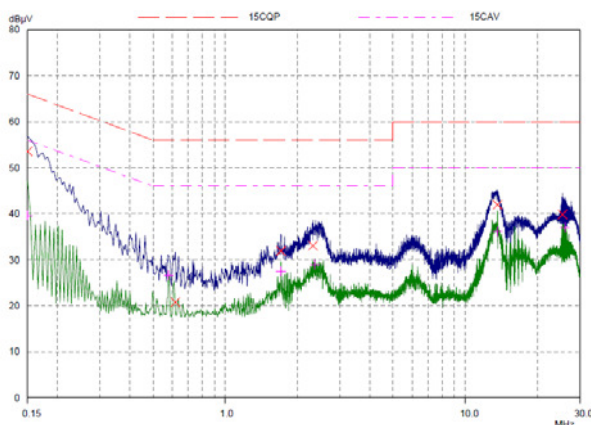

Final Measurement Results

Frequency MHz	QP Level dBuV	QP Limit dBuV	QP Delta dB	Phase	PE
0.15	53.58	66.00	12.42	L1	gnd
0.61875	20.78	56.00	35.22	L1	gnd
1.70468	31.89	56.00	24.11	L1	gnd
2.31796	33.05	56.00	22.95	L1	gnd
13.62656	41.93	60.00	18.07	L1	gnd
25.42343	39.86	60.00	20.14	L1	gnd

Frequency MHz	AV Level dBuV	AV Limit dBuV	AV Delta dB	Phase	PE
0.15	39.62	56.00	16.38	L1	gnd
0.57968	26.65	46.00	19.35	L1	gnd
1.70468	27.48	46.00	18.52	L1	gnd
2.36484	28.94	46.00	17.06	L1	gnd
13.62656	36.16	50.00	13.84	L1	gnd
25.97031	36.98	50.00	13.02	L1	gnd



N Line

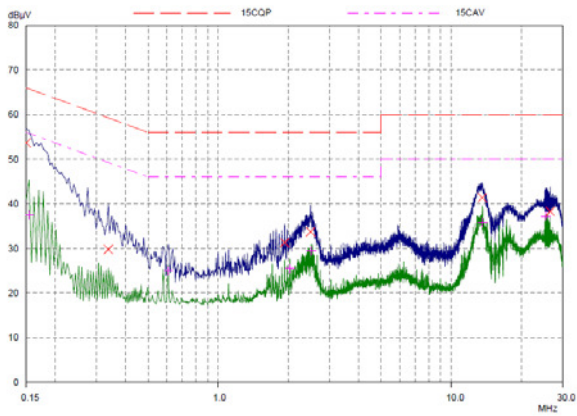

Final Measurement Results

Frequency MHz	QP Level dBuV	QP Limit dBuV	QP Delta dB	Phase	PE
0.15	53.64	66.00	12.36	N	gnd
0.3375	29.77	59.26	29.49	N	gnd
1.92734	31.29	56.00	24.71	N	gnd
2.48984	33.75	56.00	22.25	N	gnd
13.5914	41.38	60.00	18.62	N	gnd
26.59921	38.29	60.00	21.71	N	gnd

Frequency MHz	AV Level dBuV	AV Limit dBuV	AV Delta dB	Phase	PE
0.1539	37.53	55.79	18.26	N	gnd
0.61093	24.97	46.00	21.03	N	gnd
2.0289	25.49	46.00	20.51	N	gnd
2.50546	29.41	46.00	16.59	N	gnd
13.59531	35.83	50.00	14.17	N	gnd
25.50546	37.23	50.00	12.77	N	gnd

802.11n(HT40), Channel No.: 9

L Line

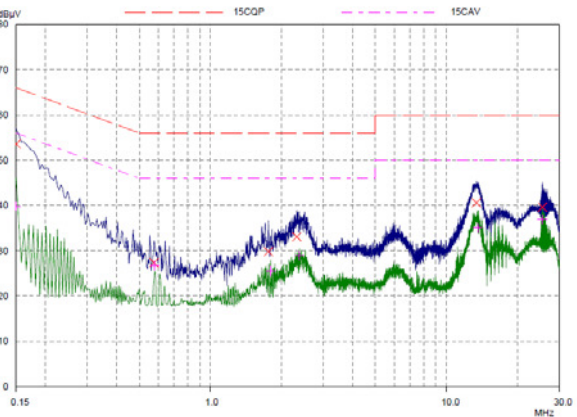

Final Measurement Results

Frequency MHz	QP Level dBuV	QP Limit dBuV	QP Delta dB	Phase	PE
0.15	53.60	66.00	12.40	L1	gnd
0.57578	27.33	56.00	28.67	L1	gnd
1.75937	29.79	56.00	26.21	L1	gnd
2.31796	33.11	56.00	22.89	L1	gnd
13.37656	40.59	60.00	19.41	L1	gnd
25.50156	39.59	60.00	20.41	L1	gnd

Frequency MHz	AV Level dBuV	AV Limit dBuV	AV Delta dB	Phase	PE
0.15	39.79	56.00	16.21	L1	gnd
0.57968	26.72	46.00	19.28	L1	gnd
1.79843	25.56	46.00	20.44	L1	gnd
2.38437	28.89	46.00	17.11	L1	gnd
13.57187	35.06	50.00	14.94	L1	gnd
25.50156	36.97	50.00	13.03	L1	gnd

N Line

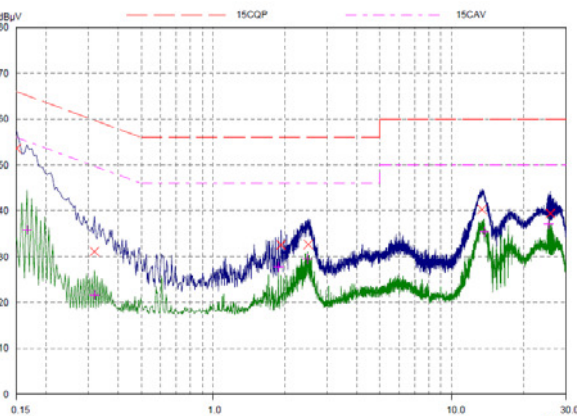

Final Measurement Results

Frequency MHz	QP Level dBuV	QP Limit dBuV	QP Delta dB	Phase	PE
0.15	53.60	66.00	12.40	N	gnd
0.31796	31.14	59.76	28.62	N	gnd
1.92343	32.58	56.00	23.42	N	gnd
2.50156	32.67	56.00	23.33	N	gnd
13.38828	40.32	60.00	19.68	N	gnd
25.89609	39.45	60.00	20.55	N	gnd

Frequency MHz	AV Level dBuV	AV Limit dBuV	AV Delta dB	Phase	PE
0.16562	35.90	55.18	19.28	N	gnd
0.31796	21.69	49.76	28.07	N	gnd
1.87656	27.77	46.00	18.23	N	gnd
2.48984	29.46	46.00	16.54	N	gnd
13.66171	35.42	50.00	14.58	N	gnd
25.50546	37.10	50.00	12.90	N	gnd



Zigbee, Channel No.: 11

L Line

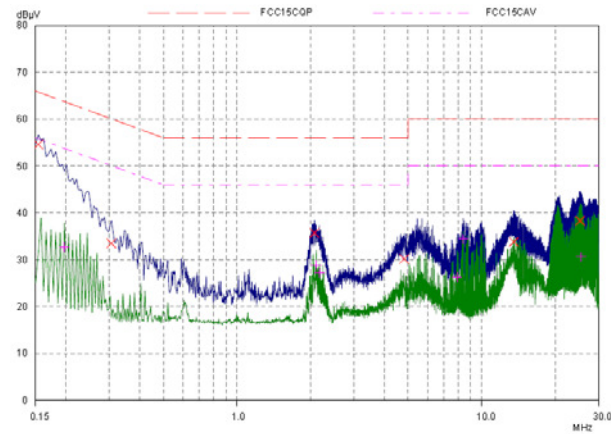

Final Measurement Results

Frequency MHz	QP Level dBµV	QP Limit dBµV	QP Delta dB	Phase	PE
0.1539	54.58	65.79	11.21	L1	gnd
0.30625	33.48	60.07	26.59	L1	gnd
2.07187	35.70	56.00	20.30	L1	gnd
4.82187	30.16	56.00	25.84	L1	gnd
13.50937	33.78	60.00	26.22	L1	gnd
25.25937	38.32	60.00	21.68	L1	gnd

Frequency MHz	AV Level dBµV	AV Limit dBµV	AV Delta dB	Phase	PE
0.19687	32.73	53.74	21.01	L1	gnd
2.10703	28.83	46.00	17.17	L1	gnd
2.16953	27.22	46.00	18.78	L1	gnd
7.94296	26.20	50.00	23.80	L1	gnd
8.40781	34.36	50.00	15.64	L1	gnd
25.49375	30.59	50.00	19.41	L1	gnd

N Line

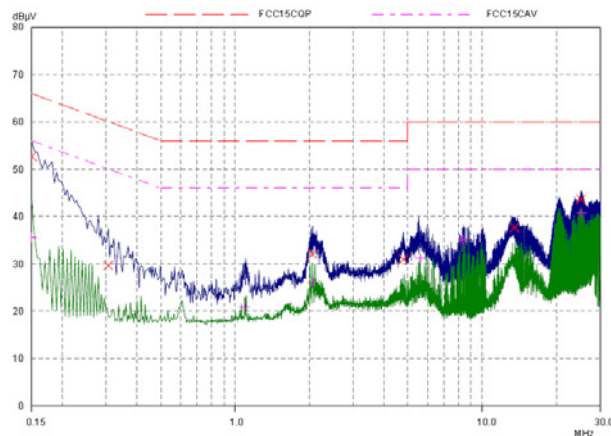

Final Measurement Results

Frequency MHz	QP Level dBµV	QP Limit dBµV	QP Delta dB	Phase	PE
0.15	52.70	66.00	13.30	N	gnd
0.30625	29.70	60.07	30.37	N	gnd
2.05625	32.04	56.00	23.96	N	gnd
4.79843	31.00	56.00	25.00	N	gnd
13.50937	37.68	60.00	22.32	N	gnd
25.11093	43.69	60.00	16.31	N	gnd

Frequency MHz	AV Level dBµV	AV Limit dBµV	AV Delta dB	Phase	PE
0.15	35.61	56.00	20.39	N	gnd
1.0914	20.95	46.00	25.05	N	gnd
2.05625	26.06	46.00	19.94	N	gnd
5.60703	31.12	50.00	18.88	N	gnd
8.40781	35.14	50.00	14.86	N	gnd
25.26718	40.76	50.00	9.24	N	gnd

Zigbee, Channel No.: 18

L Line

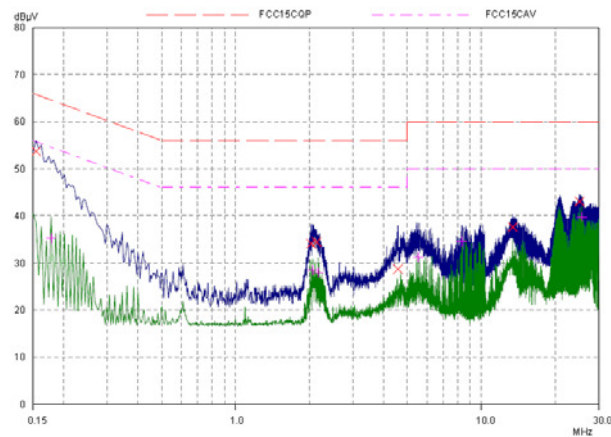

Final Measurement Results

Frequency MHz	QP Level dBµV	QP Limit dBµV	QP Delta dB	Phase	PE
0.1539	53.74	65.79	12.05	L1	gnd
2.0289	34.09	56.00	21.91	L1	gnd
2.13437	34.44	56.00	21.56	L1	gnd
4.57968	28.71	56.00	27.29	L1	gnd
13.42343	37.64	60.00	22.36	L1	gnd
25.09531	43.08	60.00	16.92	L1	gnd

Frequency MHz	AV Level dBµV	AV Limit dBµV	AV Delta dB	Phase	PE
0.17734	35.32	54.61	19.29	L1	gnd
2.06015	28.49	46.00	17.51	L1	gnd
2.18562	27.93	46.00	18.07	L1	gnd
5.525	31.26	50.00	18.74	L1	gnd
8.32578	34.56	50.00	15.44	L1	gnd
25.63828	39.80	50.00	10.20	L1	gnd

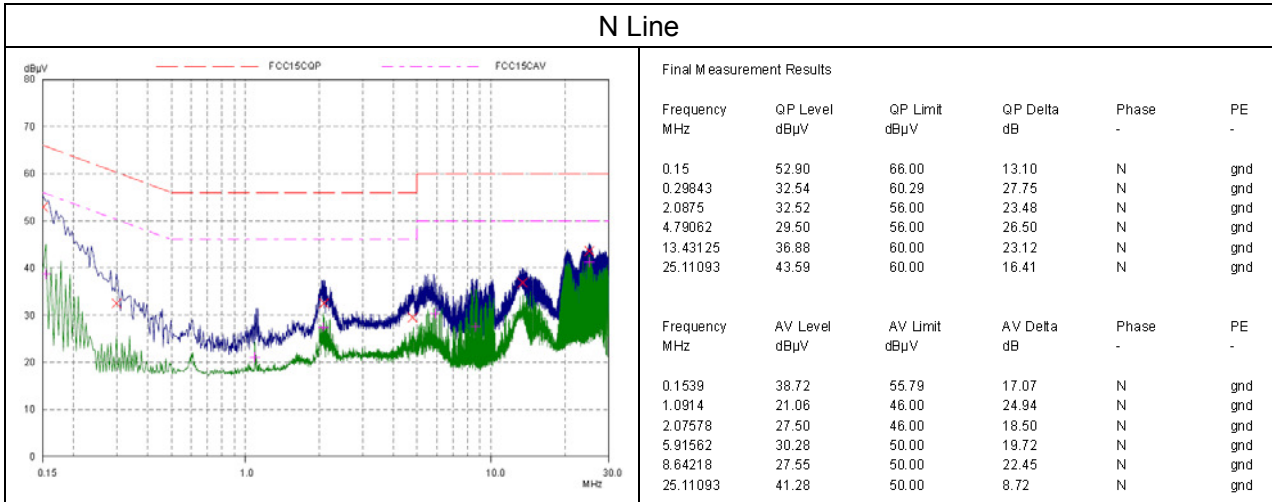

Zigbee, Channel No.: 25

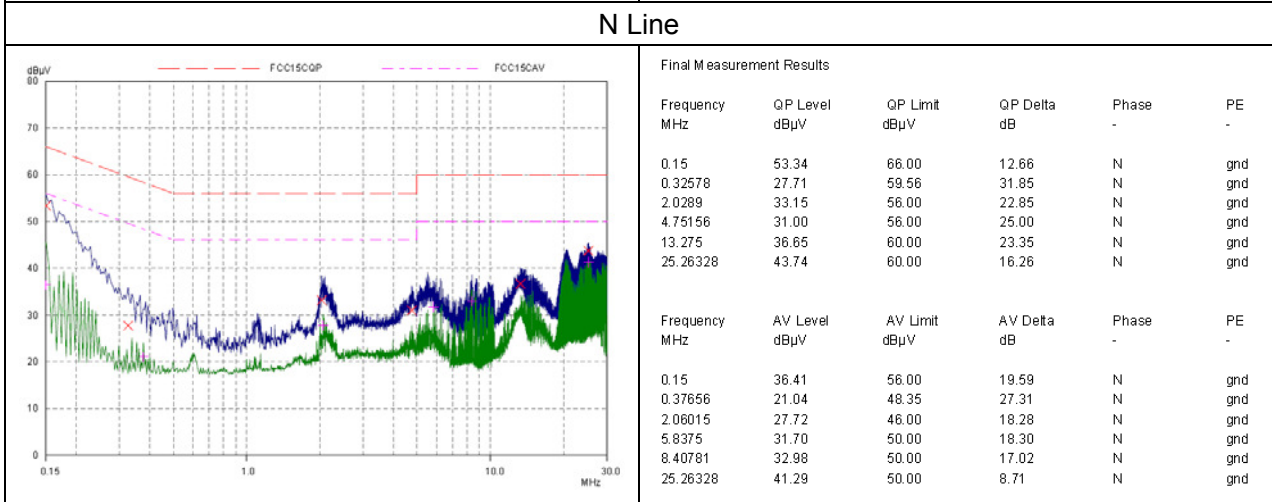
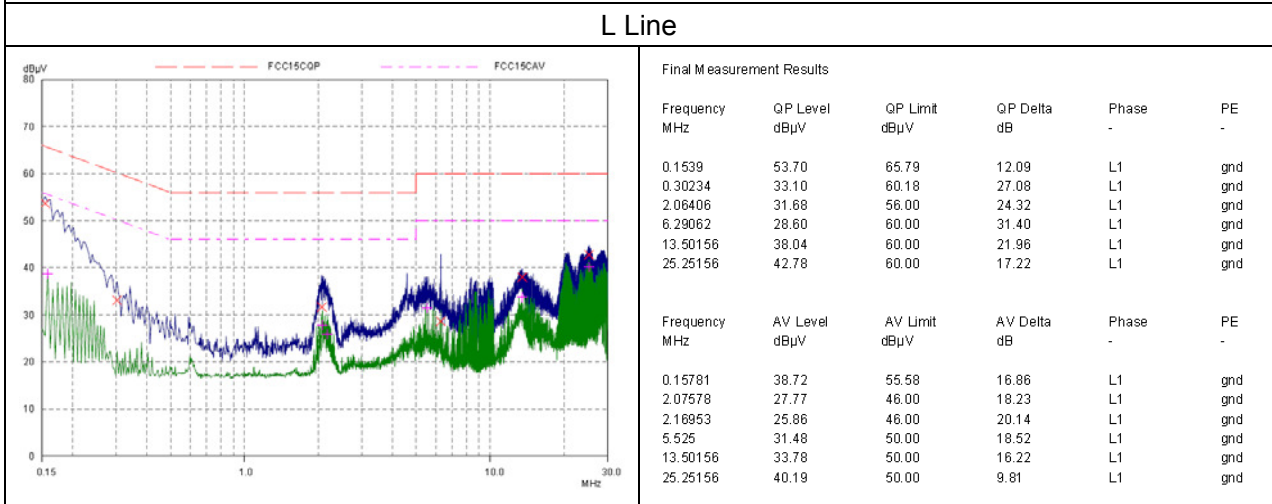



6. Main Test Instruments

Name	Type	Manufacturer	Serial Number	Calibration Date	Expiration Time
EMI Test Receiver	ESCI	R&S	100948	2015-05-22	2016-05-21
Loop Antenna	FMZB1519	SCHWARZBECK	1519-047	2014-02-29	2017-02-28
TRILOG Broadband Antenna	VULB 9163	Schwarzbeck	9163-201	2014-12-06	2017-12-05
Double Ridged Waveguide Horn Antenna	HF907	R&S	100126	2014-12-06	2017-12-05
Standard Gain Horn	3160-09	ETS-Lindgren	00102644	2015-01-30	2018-01-29
EMI Test Receiver	ESCS30	R&S	100138	2015-12-17	2016-12-16
LISN	ENV216	R&S	101171	2013-12-18	2016-12-17
Spectrum Analyzer	N9010A	Agilent	MY47191109	2015-05-22	2016-05-21
MOB COMMS DC SUPPLY	66319D	Agilent	MY43004105	2015-05-22	2016-05-21
Peak Power Meter	8990B	Agilent	51000109	2016-04-26	2017-04-25
Wideband Power Sensors	N1923A	Agilent	MY51220004	2016-04-26	2017-04-25
Spectrum Analyzer	FSV30	R&S	100815	2015-12-17	2016-12-16
RF Cable	SMA 15cm	Agilent	0001	2016-03-09	2016-06-08

*****END OF REPORT *****

ANNEX A: EUT Appearance and Test Setup

A.1 EUT Appearance



Front Side



Back Side

Picture 1 EUT

A.2 Test Setup



30M Hz-1GHz



Above 1GHz

Picture 2 Radiated Emission Test Setup



Picture 3 Conducted Emission Test Setup