



中国认可  
国际互认  
检测  
TESTING  
CNAS L2264

## RF TEST REPORT

**Applicant** Alcatel-Lucent Shanghai Bell Co., Ltd.  
**FCC ID** 2ADZRG240WZA  
**Brand** NOKIA  
**Product** Digital Home ONU  
**Model** G-240WZ-A  
**Report No.** YBA1610-0091RF01  
**Issue Date** October 21, 2016

TA Technology (Shanghai) Co., Ltd. tested the above equipment in accordance with the requirements in **FCC CFR47 Part 15C (2016)**. The test results show that the equipment tested is capable of demonstrating compliance with the requirements as documented in this report.

Performed by: Xianqing Li

Approved by: Kai Xu

---

### TA Technology (Shanghai) Co., Ltd.

No.145, Jintang Rd, Tangzhen Industry Park, Pudong Shanghai, China

TEL: +86-021-50791141/2/3

FAX: +86-021-50791141/2/3-8000



## TABLE OF CONTENT

1. Test Laboratory .....	4
1.1. Notes of the test report.....	4
1.2. Test facility .....	4
1.3. Testing Location.....	5
2. General Description of Equipment under Test.....	6
3. Applied Standards .....	8
4. Test Configuration .....	9
5. Test Case Results .....	10
5.1. Peak Power Output –Conducted .....	10
5.2. 6dB Bandwidth .....	13
5.3. Band Edge .....	18
5.4. Power Spectral Density .....	21
5.5. Spurious RF Conducted Emissions.....	26
5.6. Radiated Emissions in the Restricted Band .....	42
5.7. Radiates Emission .....	47
5.8. Conducted Emission .....	110
6. Main Test Instruments.....	121
ANNEX A: EUT Appearance and Test Setup .....	122
A.1 EUT Appearance .....	122
A.2 Test Setup .....	123



## Summary of measurement results

Number	Summary of measurements of results	Clause in FCC rules	Verdict
1	Maximum peak conducted output power	15.247(b)(3)	PASS
2	6 dB bandwidth	15.247(a)(2)	PASS
3	Maximum power spectral density	15.247(e)	PASS
4	Band Edge	15.247(d)	PASS
5	Spurious RF Conducted Emissions	15.247(d)	PASS
6	Radiated Emissions in restricted frequency bands	15.247(d),15.205,15.209	PASS
7	Radiated Emissions	15.247(d),15.205,15.209	PASS
8	Conducted Emissions	15.207	PASS
Date of Testing: April 15, 2016~ May 6, 2016			

## 1. Test Laboratory

### 1.1. Notes of the test report

This report shall not be reproduced in full or partial, without the written approval of **TA technology (shanghai) co., Ltd.** The results documented in this report apply only to the tested sample, under the conditions and modes of operation as described herein .Measurement Uncertainties were not taken into account and are published for informational purposes only. This report is written to support regulatory compliance of the applicable standards stated above. This report must not be used by the client to claim product certification, approval, or endorsement by CNAS or any government agencies.

### 1.2. Test facility

#### **CNAS (accreditation number:L2264)**

TA Technology (Shanghai) Co., Ltd. has obtained the accreditation of China National Accreditation Service for Conformity Assessment (CNAS).

#### **FCC (recognition number is 428261)**

TA Technology (Shanghai) Co., Ltd. has been listed on the US Federal Communications Commission list of test facilities recognized to perform electromagnetic emissions measurements.

#### **IC (recognition number is 8510A)**

TA Technology (Shanghai) Co., Ltd. has been listed by industry Canada to perform electromagnetic emission measurement.

#### **VCCI (recognition number is C-4595, T-2154, R-4113, G-766)**

TA Technology (Shanghai) Co., Ltd. has been listed by industry Japan to perform electromagnetic emission measurement.

#### **A2LA (Certificate Number: 3857.01)**

TA Technology (Shanghai) Co., Ltd. has been listed by American Association for Laboratory Accreditation to perform electromagnetic emission measurement.



### 1.3. Testing Location

Company: TA Technology (Shanghai) Co., Ltd.  
Address: No.145, Jintang Rd, Tangzhen Industry Park, Pudong  
City: Shanghai  
Post code: 201201  
Country: P. R. China  
Contact: Xu Kai  
Telephone: +86-021-50791141/2/3  
Fax: +86-021-50791141/2/3-8000  
Website: <http://www.ta-shanghai.com>  
E-mail: [xukai@ta-shanghai.com](mailto:xukai@ta-shanghai.com)

## 2. General Description of Equipment under Test

### Client Information

<b>Applicant</b>	Alcatel-Lucent Shanghai Bell Co., Ltd.
<b>Applicant address</b>	388-389#, Ningqiao Road, Pudong Jinqiao, Shanghai P.R. China
<b>Manufacturer</b>	Taicang T&W Electronics Co., Ltd
<b>Manufacturer address</b>	Jiangnan Road 89, Ludu Town, Taicang P.R. China

### General information

EUT Description	
Model:	G-240WZ-A
IMEI:	/
Hardware Version:	PEM 1+
Software Version:	3FE45890FFEB38
Power Supply:	AC adapter
Antenna Type:	External Antenna
Test Mode:	802.11b 802.11g, 802.11n(HT20/HT40); Zigbee
Modulation Type:	802.11b: DSSS; 802.11g/n(HT20/HT40): OFDM Zigbee: MSK
Antenna Gain:	Antenna 1: 3.00 dBi Antenna 2: 3.00 dBi Antenna 3: 3.00 dBi
Directional Gain:	3.00 dBi
additional beamforming gain:	0 dB
Max. Conducted Power	Wi-Fi 2.4G: 26.67 dBm Zigbee: 21.343 dBm
Operating Frequency Range(s)	2400 ~ 2483.5 MHz
EUT Accessory	
Adapter 1	Manufacture: DONGGUAN SHILONG FUHUA ELECTRONIC CO.,LTD. Model : UES36-120300SPA1 PN: UE160529GWAD01-P
Adapter 2	Manufacture: DONGGUAN SHILONG FUHUA ELECTRONIC CO.,LTD.



	Model : UES36-120300SPA1 PN: UE160523GWAD01-P
Adapter 3	Manufacture: CyberPower Systems (USA), Inc. Model : DTC36U12V3-G
Note: The information of the EUT is declared by the manufacturer. Please refer to the specifications or user manual for details. Note: Manufacturer declared that only single TX under single rate and MIMO TX with Nss=3 are supported by the EUT.	



### **3. Applied Standards**

According to the specifications of the manufacturer, it must comply with the requirements of the following standards:

**FCC CFR47 Part 15C (2016) Radio Frequency Devices**

**ANSI C63.10 (2013)**

**KDB 558074 D01 DTS Meas Guidance v03r05**

**KDB 662911 D01 Multiple Transmitter Output v02r01**



## 4. Test Configuration

### Test Mode

The EUT was programmed to be in continuously transmitting mode and the transmit duty cycle is not less than 98%.

The EUT has been associated with peripherals and configuration operated in a manner tended to maximize its emission characteristics in a typical application.

The radiated emission was measured in the following position: EUT stand-up position (Z axis), lie-down position (X, Y axis). The worst emission was found in stand-up position (Z axis) and the worst case was recorded.

In order to find the worst case condition, Pre-tests are needed at the presence of different data rate. Preliminary tests have been done on all the configuration for confirming worst case. Data rate below means worst-case rate of each test item.

Worst-case data rates are shown as following table.

Band	Data Rate			
	Antenna 1	Antenna 2	Antenna 3	MIMO
802.11b	1 Mbps	1 Mbps	1 Mbps	--
802.11g	6 Mbps	6 Mbps	6 Mbps	--
802.11n HT20	MCS0	MCS0	MCS0	MCS8
802.11n HT40	MCS0	MCS0	MCS0	MCS8

The EUT is 3x3 MIMO antennas, for RE&CE, In order to find the worst antenna; Pre-tests are needed at the presence of different antenna. And the worst antenna was recorded for RE&CE.

The worst case Antenna mode for each of the following tests for Wi-Fi:

Test Cases	Antenna 1	Antenna 2	Antenna 3	MIMO
Maximum peak conducted output power	O	O	O	802.11n HT20/40
6 dB bandwidth	O	-	-	-
Maximum power spectral density	O	-	-	802.11n HT20/40
Band Edge	O	-	-	-
Spurious RF Conducted Emissions	O	O	O	802.11n HT20/40
Radiated Emissions in restricted frequency bands	O	-	-	-
Radiated Emissions	O	-	-	-
Conducted Emissions	O	-	-	-

Note: "O": test all bands

## 5. Test Case Results

### 5.1. Peak Power Output –Conducted

#### Ambient condition

Temperature	Relative humidity	Pressure
23°C ~25°C	45%~50%	101.5kPa

#### Methods of Measurement

During the process of the testing, The EUT was connected to the spectrum analyzer with a known loss. The EUT is max power transmission with proper modulation. The peak detector is used. We use Maximum Peak Conducted Output Power Level Method in KDB 558074 D01 for this test.

The conducted Power is measured at each antenna port. The measured results at the various antenna ports are then summed mathematically.

#### Test Setup

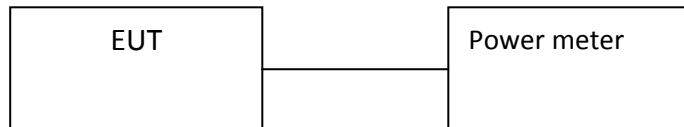

#### Limits

Rule Part 15.247 (b) (3) specifies that " For systems using digital modulation in the 902–928 MHz, 2400–2483.5 MHz: 1 Watt."

Peak Output Power	$\leq 1W$ (30dBm)
-------------------	-------------------

#### Measurement Uncertainty

The assessed measurement uncertainty to ensure 95% confidence level for the normal distribution is with the coverage factor  $k = 2$ ,  $U = 0.44$  dB.



## Test Results

Power Index			
Packet Type	CH1	CH6	CH11
802.11b	100	100	100
802.11g	42	88	42
802.11n HT20	40	88	42
802.11n HT20 (MIMO)	40	72	44
Packet Type	CH3	CH6	CH9
802.11n HT40	40	88	40
802.11n HT40 (MIMO)	40	72	44

Network Standards		Carrier frequency (MHz)	Peak Output Power (dBm)	Limit (dBm)	Conclusion
Ant 1	802.11b	2412	25.60	30	PASS
		2437	25.59	30	PASS
		2462	25.72	30	PASS
	802.11g	2412	12.03	30	PASS
		2437	26.12	30	PASS
		2462	12.98	30	PASS
	802.11n HT20	2412	10.64	30	PASS
		2437	26.02	30	PASS
		2462	10.55	30	PASS
	802.11n HT40	2422	10.91	30	PASS
		2437	26.30	30	PASS
		2452	10.84	30	PASS
Ant 2	802.11b	2412	25.25	30	PASS
		2437	25.46	30	PASS
		2462	25.46	30	PASS
	802.11g	2412	11.76	30	PASS
		2437	25.74	30	PASS
		2462	12.05	30	PASS
	802.11n HT20	2412	10.42	30	PASS
		2437	25.96	30	PASS
		2462	10.38	30	PASS
	802.11n HT40	2422	10.88	30	PASS
		2437	26.50	30	PASS
		2452	10.76	30	PASS



Ant 3	802.11b	2412	25.31	30	PASS
		2437	25.05	30	PASS
		2462	25.24	30	PASS
	802.11g	2412	11.33	30	PASS
		2437	25.42	30	PASS
		2462	11.95	30	PASS
	802.11n HT20	2412	10.38	30	PASS
		2437	25.88	30	PASS
		2462	10.32	30	PASS
	802.11n HT40	2422	10.65	30	PASS
		2437	26.05	30	PASS
		2452	10.58	30	PASS
Zigbee	2405	19.721	30	PASS	
	2440	21.343	30	PASS	
	2475	20.604	30	PASS	

**MIMO**

Network Standards	Carrier frequency (MHz)	Ant 0	Ant 1	Ant 2	Peak Output Power (dBm)	Limit (dBm)	Conclusion
802.11n HT20	2412	14.39	15.29	14.48	19.51	30	PASS
	2437	21.68	22.29	21.7	26.67	30	PASS
	2462	15.65	16.4	15.61	20.67	30	PASS
802.11n HT40	2422	15.33	15.81	15.88	20.45	30	PASS
	2437	21.59	21.9	21.79	26.53	30	PASS
	2452	15.26	15.69	15.3	20.19	30	PASS

## 5.2. 6dB Bandwidth

### Ambient condition

Temperature	Relative humidity	Pressure
23°C ~25°C	45%~50%	101.5kPa

### Method of Measurement

The EUT was connected to the spectrum analyzer through an external attenuator (20dB) and a known loss cable. RBW is set to 100 kHz; VBW is set to 300 kHz on spectrum analyzer.

### Test Setup

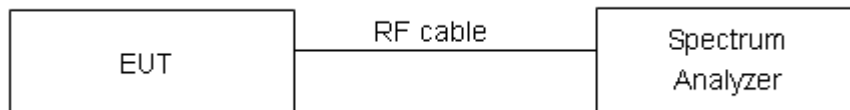

### Limits

Rule Part 15.247 (a) (2) specifies that “Systems using digital modulation techniques may operate in the 902–928 MHz, 2400–2483.5 MHz bands. The minimum 6 dB bandwidth shall be at least 500 kHz.”

minimum 6 dB bandwidth	≥ 500 kHz
------------------------	-----------

### Measurement Uncertainty

The assessed measurement uncertainty to ensure 95% confidence level for the normal distribution is with the coverage factor  $k = 2$ ,  $U = 936$  Hz.

**Test Results:**

Network Standards		Carrier frequency (MHz)	Minimum 6 dB bandwidth (MHz)	Limit(kHz)	Conclusion
Ant 1	802.11b	2412	8.117	500	PASS
		2437	8.100	500	PASS
		2462	8.115	500	PASS
	802.11g	2412	15.920	500	PASS
		2437	16.480	500	PASS
		2462	16.520	500	PASS
	802.11n HT20	2412	17.691	500	PASS
		2437	17.680	500	PASS
		2462	17.695	500	PASS
	802.11n HT40	2422	36.210	500	PASS
		2437	36.370	500	PASS
		2452	36.211	500	PASS
Zigbee		2405	1.539	500	PASS
		2440	1.289	500	PASS
		2475	1.387	500	PASS



802.11b, Carrier frequency (MHz): 2412



802.11g, Carrier frequency (MHz): 2412



802.11b, Carrier frequency (MHz): 2437



802.11g, Carrier frequency (MHz): 2437



802.11b, Carrier frequency (MHz): 2462



802.11g, Carrier frequency (MHz): 2462



802.11n(HT20), Carrier frequency (MHz): 2412



802.11n(HT40), Carrier frequency (MHz): 2422

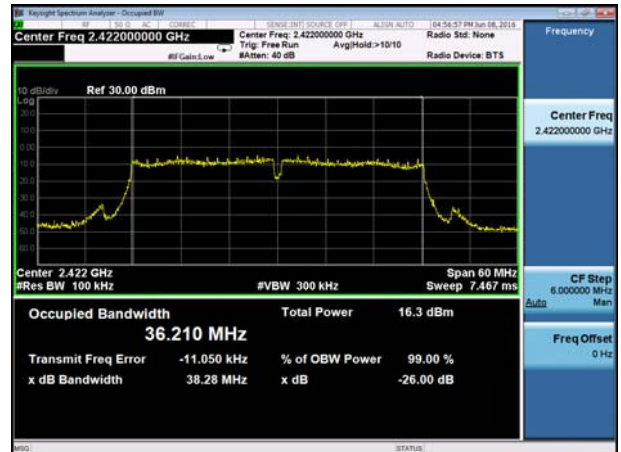

802.11n(HT20), Carrier frequency (MHz): 2437



802.11n(HT40), Carrier frequency (MHz): 2437



802.11n(HT20), Carrier frequency (MHz):2462



802.11n(HT40), Carrier frequency (MHz):2452

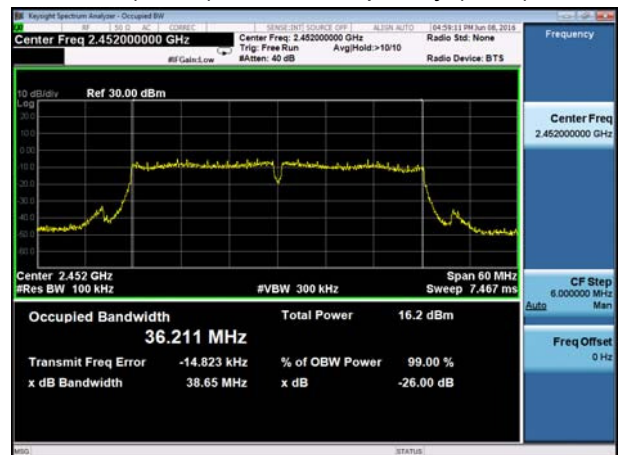





### Zigbee, Carrier frequency (MHz): 2405



### Zigbee, Carrier frequency (MHz): 2440



### Zigbee, Carrier frequency (MHz): 2475



### 5.3. Band Edge

#### Ambient condition

Temperature	Relative humidity	Pressure
23°C ~25°C	45%~50%	101.5kPa

#### Method of Measurement

The EUT was connected to the spectrum analyzer through an external attenuator (20dB) and a known loss cable the band edge of the lowest and highest channels were measured. The peak detector is used and RBW is set to 100 kHz and VBW is set to 300 kHz on spectrum analyzer. Spectrum analyzer plots are included on the following pages.

#### Test Setup

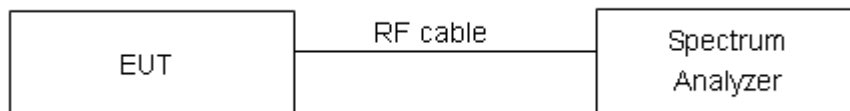

#### Limits

Rule Part 15.247(d) specifies that “In any 100 kHz bandwidth outside the frequency band in which the spread spectrum or digitally modulated intentional radiator is operating, the radio frequency power that is produced by the intentional radiator shall be at least 20 dB below that in the 100 kHz bandwidth within the band that contains the highest level of the desired power, based on either an RF conducted or a radiated measurement, provided the transmitter demonstrates compliance with the peak conducted power limits.”

#### Measurement Uncertainty

The assessed measurement uncertainty to ensure 95% confidence level for the normal distribution is with the coverage factor  $k = 1.96$ .

Frequency	Uncertainty
2GHz-3GHz	1.407 dB



Test Results: PASS

Ant 1

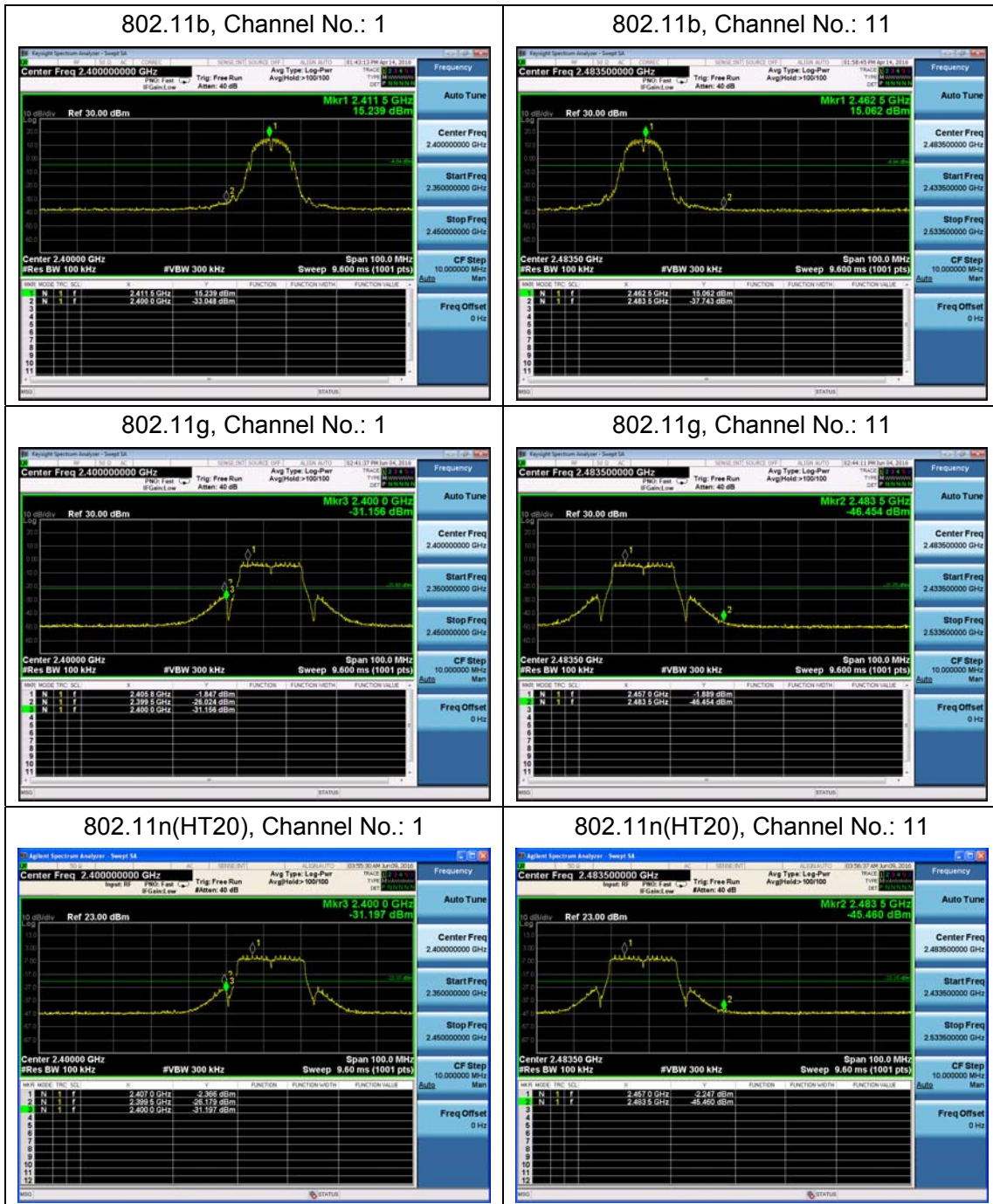

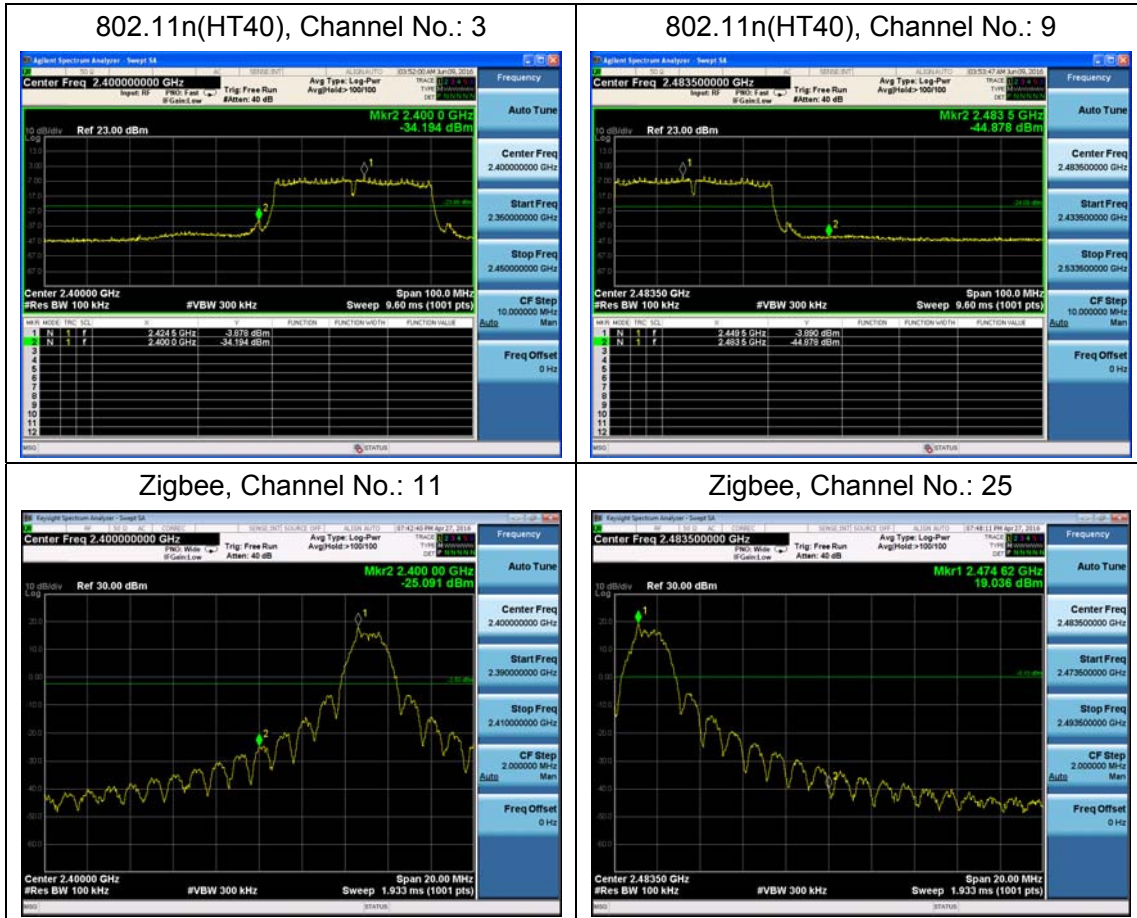

### 5.4. Power Spectral Density

#### Ambient condition

Temperature	Relative humidity	Pressure
23°C ~25°C	45%~50%	101.5kPa

#### Method of Measurement

The EUT was connected to the spectrum analyzer through an external attenuator (20dB) and a known loss cable.

RBW is set to 3 kHz and VBW is set to 10 kHz for Wi-Fi 2.4G on spectrum analyzer.

Set the span to 1.5 times the DTS channel bandwidth. Sweep time = auto couple. Trace mode = max hold. The peak power spectral density is recorded.

The conducted Power is measured at each antenna port. The measured results at the various antenna ports are then summed mathematically.

#### Test setup

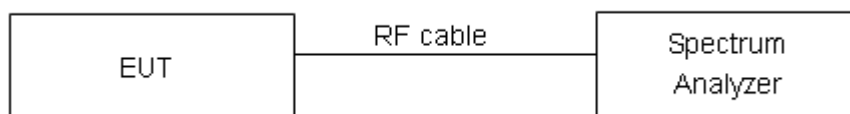

#### Limits

Rule Part 15.247(e) specifies that” For digitally modulated systems, the power spectral density conducted from the intentional radiator to the antenna shall not be greater than 8 dBm in any 3 kHz band during any time interval of continuous transmission. ”

Limits	≤ 8 dBm / 3kHz
--------	----------------

#### Measurement Uncertainty

The assessed measurement uncertainty to ensure 95% confidence level for the normal distribution is with the coverage factor  $k = 2$ ,  $U = 0.75\text{dB}$ .

**Test Results:**

Network Standards		Channel Number	Power Spectral Density (dBm / 3kHz)	Limit (dBm / 3kHz)	Conclusion	
Ant 1	802.11b	1	0.788	8	PASS	
		6	-0.060	8	PASS	
		11	0.533	8	PASS	
	802.11g	1	-15.666	8	PASS	
		6	-3.148	8	PASS	
		11	-15.189	8	PASS	
	802.11n HT20	1	-14.200	8	PASS	
		6	-2.880	8	PASS	
		11	-13.708	8	PASS	
	802.11n HT40	3	-16.832	8	PASS	
		6	-4.723	8	PASS	
		9	-16.923	8	PASS	
	MIMO	802.11n HT20	1	-9.421	8	PASS
			6	-1.737	8	PASS
			11	-7.233	8	PASS
802.11n HT40		3	-9.552	8	PASS	
		6	-3.824	8	PASS	
		9	-10.479	8	PASS	
Zigbee	11	6.033	8	PASS		
	18	7.791	8	PASS		
	25	6.904	8	PASS		

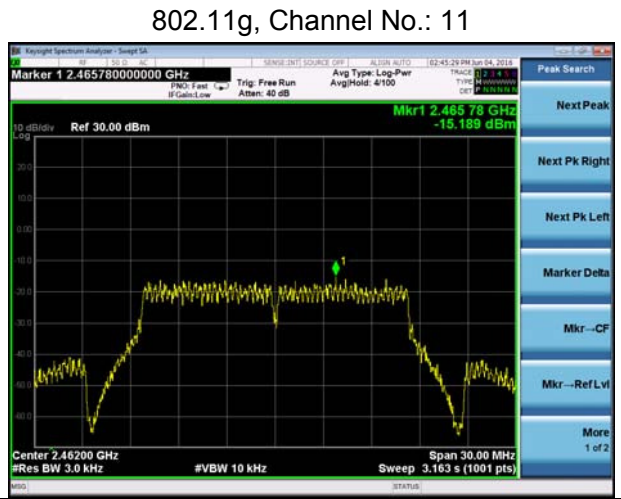
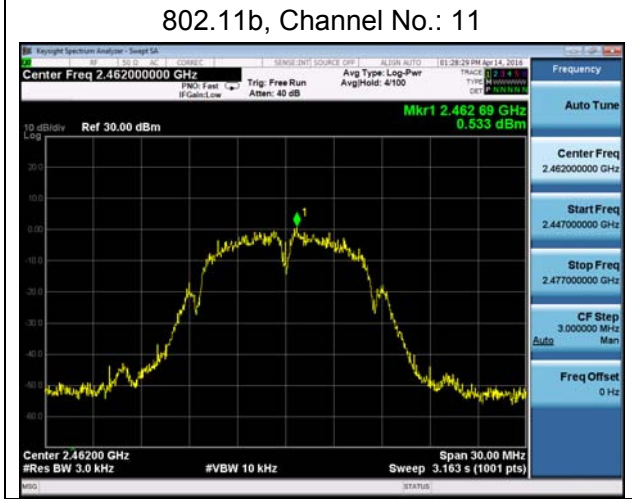
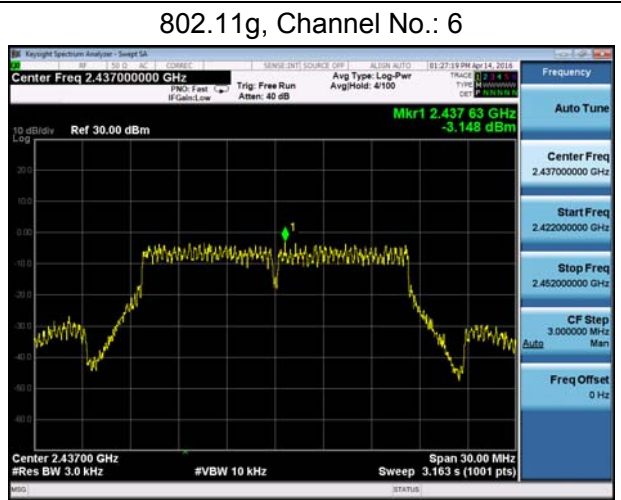
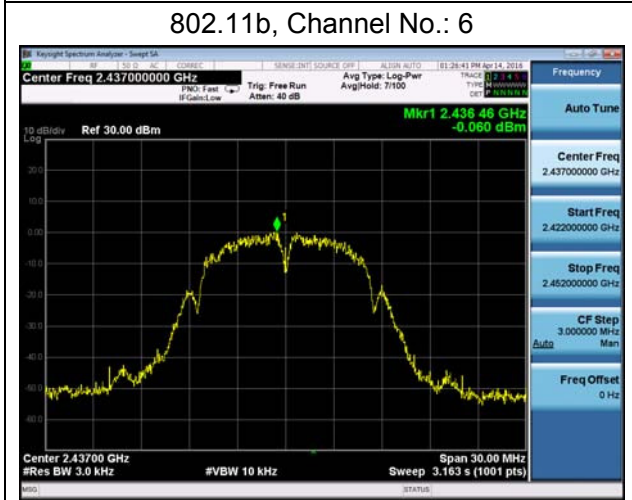
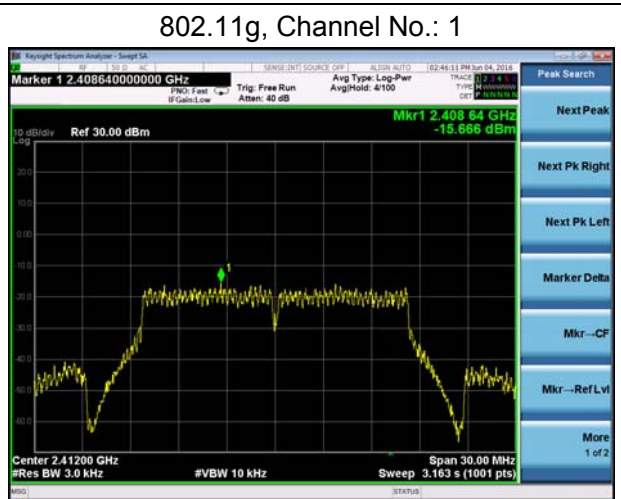
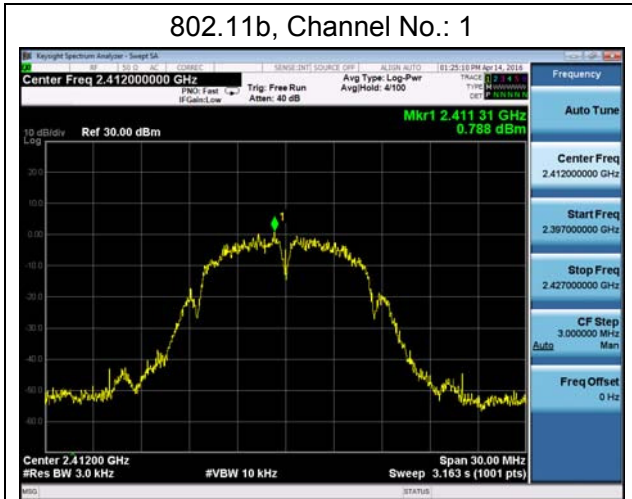



802.11n(HT20), Channel No. 1

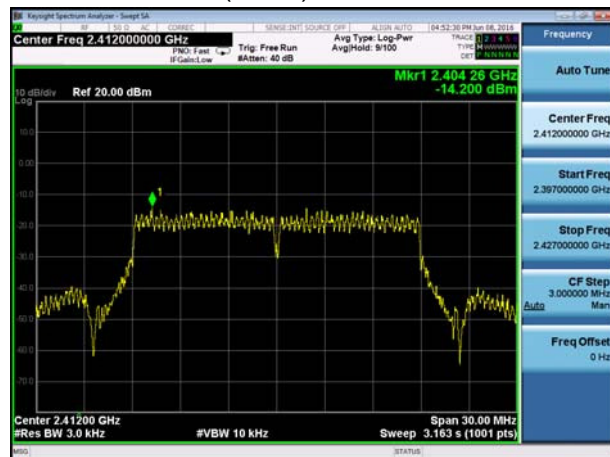

802.11n(HT40), Channel No. 3

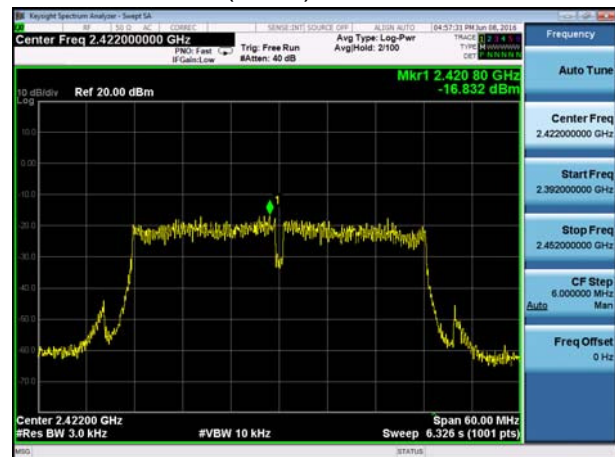

802.11n(HT20), Channel No. 6

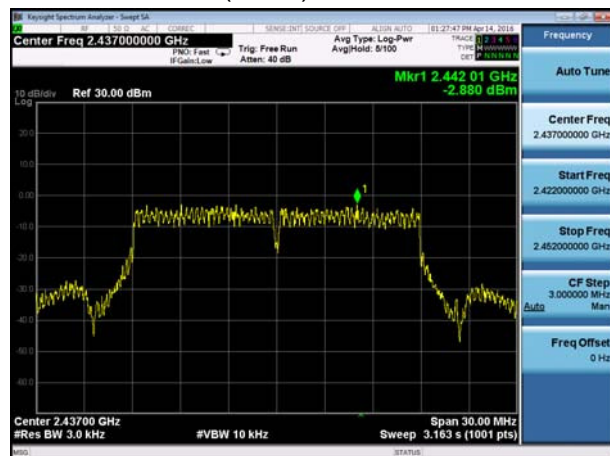

802.11n(HT40), Channel No. 6

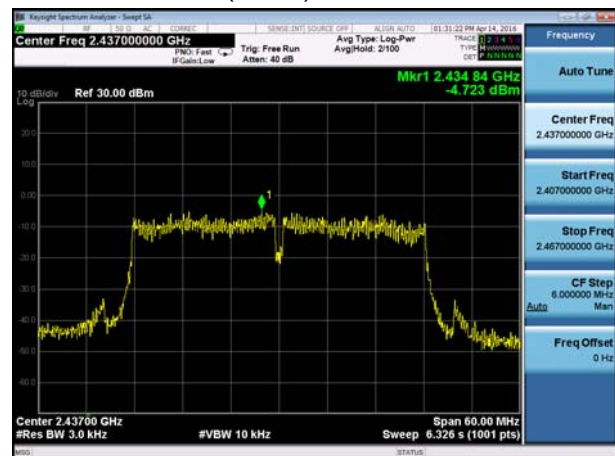

802.11n(HT20), Channel No. 11

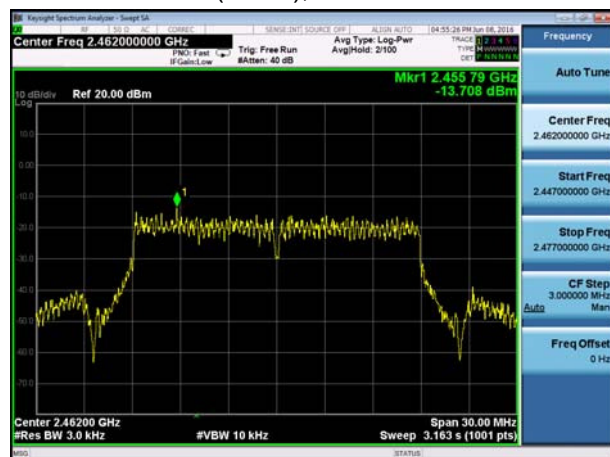

802.11n(HT40), Channel No. 9

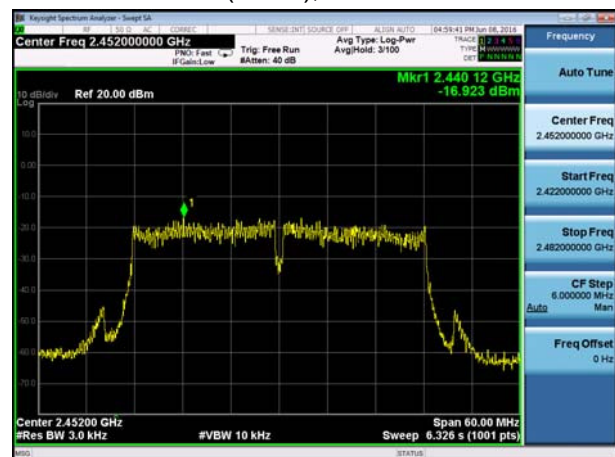





### Zigbee, Channel No.: 11

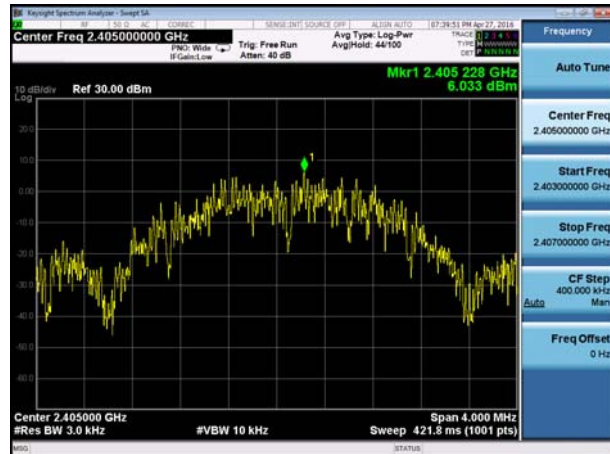

### Zigbee, Channel No.: 18

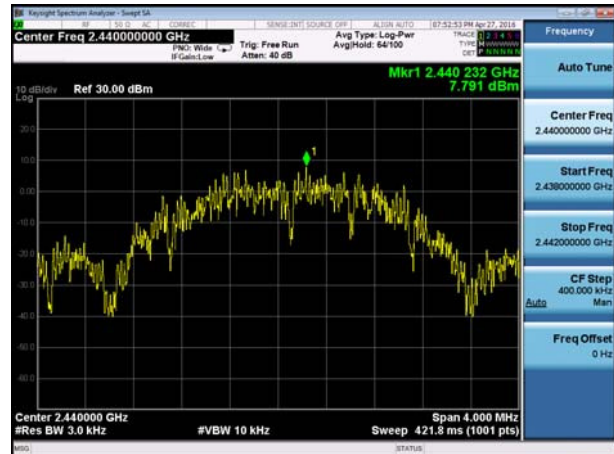

### Zigbee, Channel No.: 25

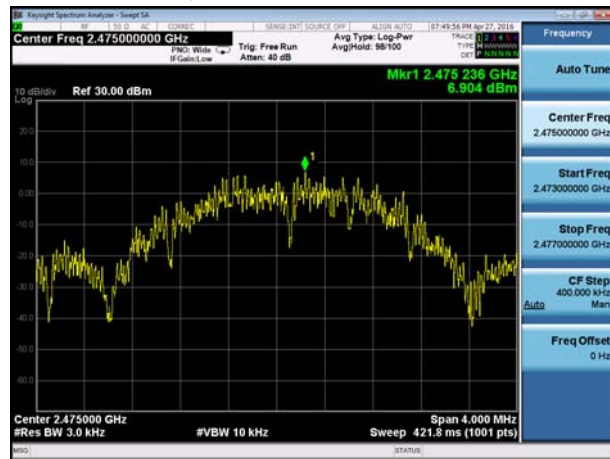

### 5.5. Spurious RF Conducted Emissions

**Ambient condition**

Temperature	Relative humidity	Pressure
23°C ~25°C	45%~50%	101.5kPa

**Method of Measurement**

The EUT was connected to the spectrum analyzer with a known loss. The spectrum analyzer scans from 30MHz to the 10th harmonic of the carrier. The peak detector is used. RBW and VBW are set to 100 kHz, Sweep is set to ATUO.

The test is in transmitting mode.

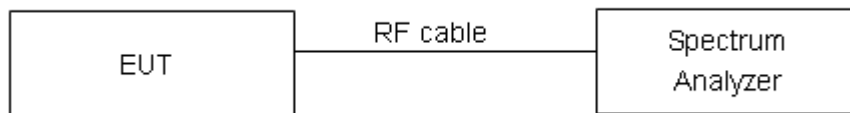

**Limits**

Rule Part 15.247(d) pacifies that “In any 100 kHz bandwidth outside the frequency band in which the spread spectrum intentional radiator is operating, the radio frequency power that is produced by the intentional radiator shall be at least 20 dB below that in the 100 kHz bandwidth within the band that contains the highest level of the desired power.”

Network Standards		Carrier frequency (MHz)	Reference value (dBm)	Limit
ANT1	802.11b	2412	-6.88	-26.88
		2437	-9.96	-29.96
		2462	-12.9	-32.90
	802.11g	2412	-12.94	-32.94
		2437	-13.06	-33.06
		2462	-8.61	-28.61
	802.11n HT20	2412	-0.04	-20.04
		2437	0.58	-19.42
		2462	-1.4	-21.40
	802.11n HT40	2422	-4.14	-24.14
		2437	-1.21	-21.21
		2452	-3.31	-23.31
ANT2	802.11b	2412	-1.69	-21.69
		2437	-2.09	-22.09
		2462	-3.75	-23.75



	802.11g	2412	-5.62	-25.62
		2437	-3.01	-23.01
		2462	-8.45	-28.45
	802.11n HT20	2412	-2.06	-22.06
		2437	-2.48	-22.48
		2462	-4.9	-24.90
	802.11n HT40	2422	-3.76	-23.76
		2437	0.27	-19.73
		2452	-1.36	-21.36
ANT3	802.11b	2412	11.31	-8.69
		2437	12.56	-7.44
		2462	13.25	-6.75
	802.11g	2412	9.32	-10.68
		2437	7.17	-12.83
		2462	7.03	-12.97
	802.11n HT20	2412	7.64	-12.36
		2437	10.29	-9.71
		2462	9.9	-10.10
	802.11n HT40	2422	8.35	-11.65
		2437	7.88	-12.12
		2452	7.68	-12.32
MIMO	802.11n HT20	2412	-0.15	-20.15
		2437	0.02	-19.98
		2462	-1.89	-21.89
	802.11n HT40	2422	-0.52	-20.52
		2437	-2.36	-22.36
		2452	-2.44	-22.44
Zigbee		2405	12.252	-7.748
		2440	-4.540	-24.54
		2475	18.763	-1.237



### Measurement Uncertainty

The assessed measurement uncertainty to ensure 95% confidence level for the normal distribution is with the coverage factor  $k = 1.96$ .

Frequency	Uncertainty
100kHz-2GHz	0.684 dB
2GHz-26GHz	1.407 dB

**Test Results:**

If disturbances were found more than 20dB below limit line, the mark is not required for the EUT.

The signal beyond the limit is carrier

Test Data File Name	Frequency (MHz)	Peak (dBm)	Margin (dB)	Limit (dB)
CSE_G240WA-Z_1#_WIFI b_CH1_ant2_0.03-18GHz	619.0	-15.54	6.85	-8.69
CSE_G240WA-Z_1#_WIFI b_CH6_ant2_0.03-18GHz	669.0	-14.94	7.50	-7.44
CSE_G240WA-Z_1#_WIFI b_CH11_ant2_0.03-18GHz	719.2	-15.91	9.16	-6.75
CSE_G240WA-Z_1#_WIFI g_CH1_ant2_0.03-18GHz	624.1	-25.98	15.30	-10.68
CSE_G240WA-Z_1#_WIFI g_CH6_ant2_0.03-18GHz	667.8	-26.99	14.16	-12.83
CSE_G240WA-Z_1#_WIFI g_CH11_ant2_0.03-18GHz	717.2	-28.92	15.95	-12.97
CSE_G240WA-Z_1#_WIFI g_CH6_ant0_0.03-18GHz	3249.0	-52.22	19.16	-33.06
CSE_G240WA-Z_1#_WIFI n(20M)_CH1_0x6_0.03-18GHz	624.1	-25.50	13.14	-12.36
CSE_G240WA-Z_1#_WIFI n(20M)_CH6_0x6_0.03-18GHz	664.1	-24.77	15.06	-9.71
CSE_G240WA-Z_1#_WIFI n(40M)_CH3_0x6_0.03-18GHz	634.8	-28.66	17.01	-11.65
CSE_G240WA-Z_1#_WIFI n(40M)_CH6_0x6_0.03-18GHz	671.7	-27.06	14.94	-12.12
CSE_G240WA-Z_1#_WIFI n(40M)_CH9_0x6_0.03-18GHz	700.3	-29.07	16.75	-12.32



ANT1

802.11b CH1 30MHz to 18GHz

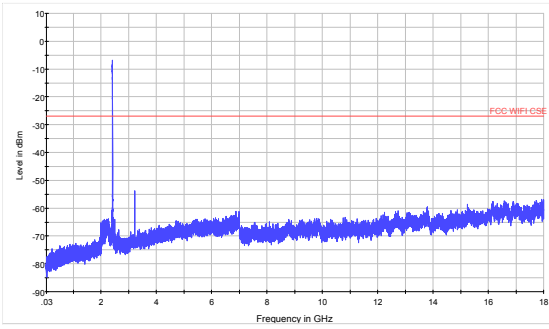

802.11b CH1 18GHz to 26.5GHz

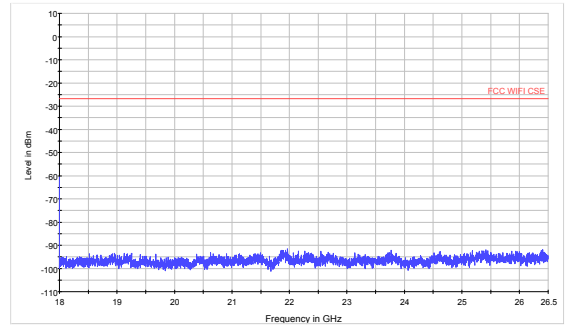

802.11b CH6 30MHz to 18GHz

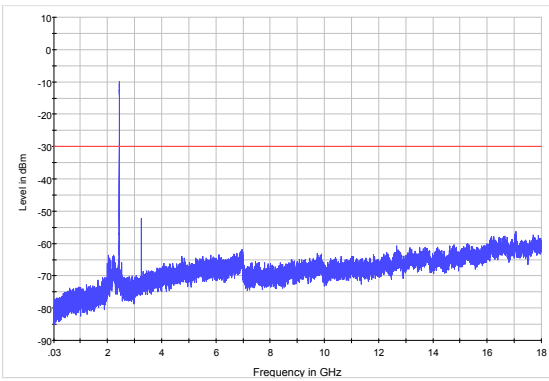

802.11b CH6 18GHz to 26.5GHz

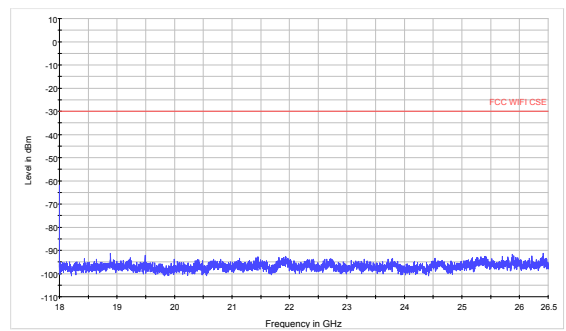

802.11b CH11 30MHz to 18GHz

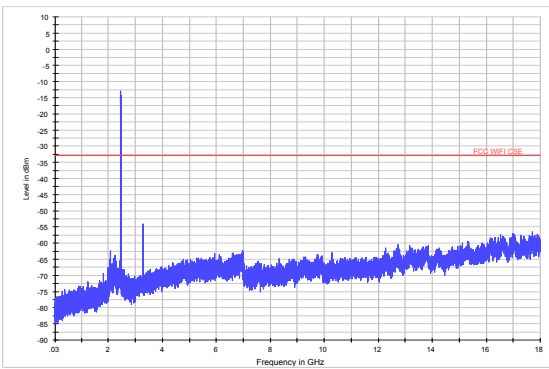

802.11b CH11 18GHz to 26.5GHz

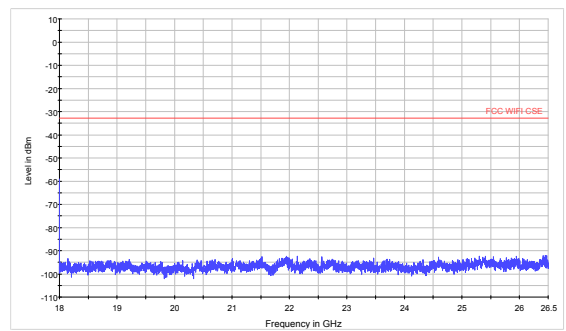

802.11g CH1 30MHz to 18GHz

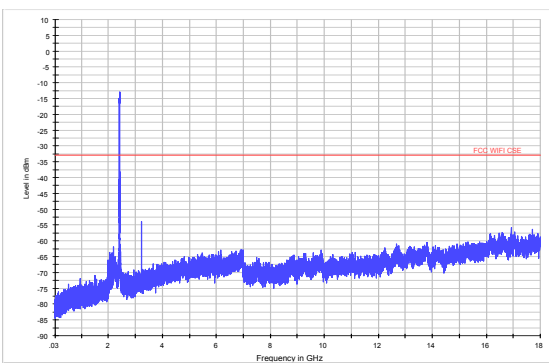

802.11g CH1 18GHz to 26.5GHz

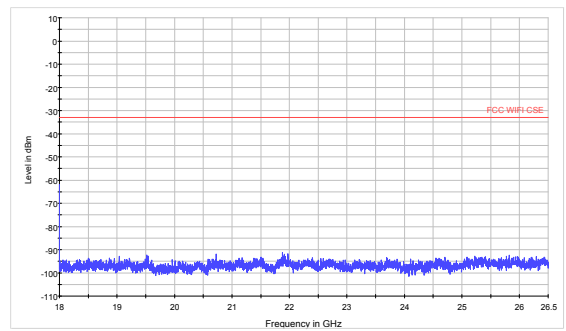



802.11g CH6 30MHz to 18GHz

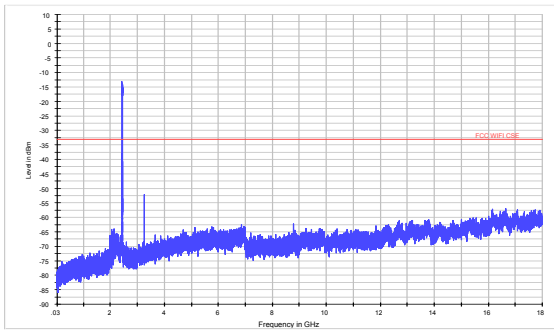

802.11g CH6 18GHz to 26.5GHz

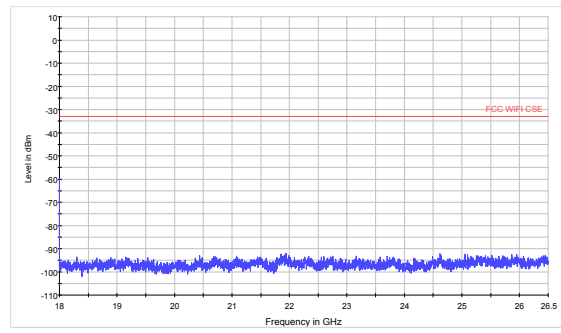

802.11g CH11 30MHz to 18GHz

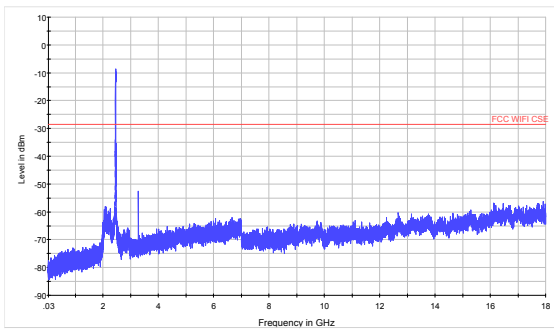

802.11g CH11 18GHz to 26.5GHz

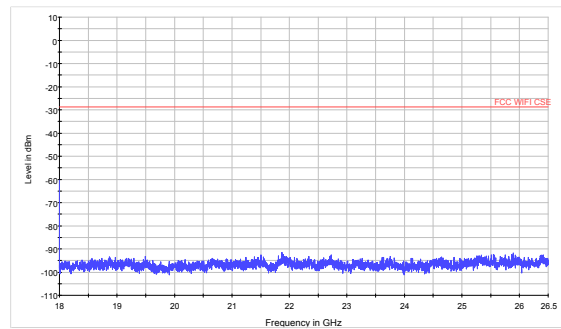

802.11n(HT20) CH1 30MHz to 18GHz

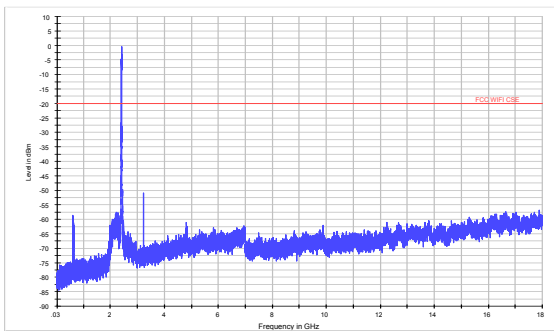

802.11n(HT20) CH1 18GHz to 26.5GHz

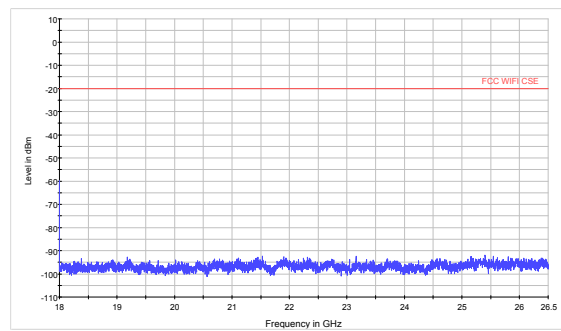

802.11n(HT20) CH6 30MHz to 18GHz

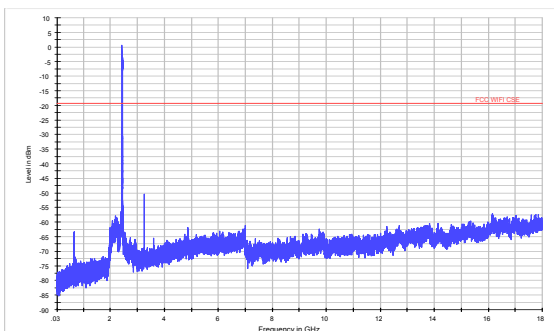

802.11n(HT20) CH6 18GHz to 26.5GHz

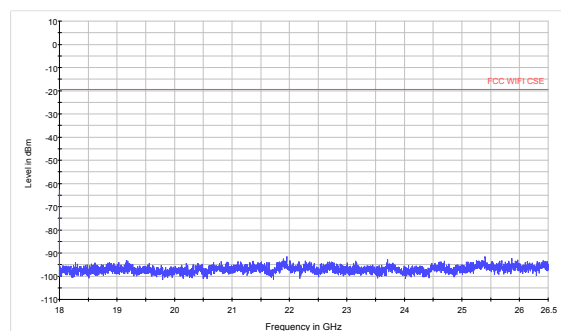

802.11n(HT20) CH11 30MHz to 18GHz

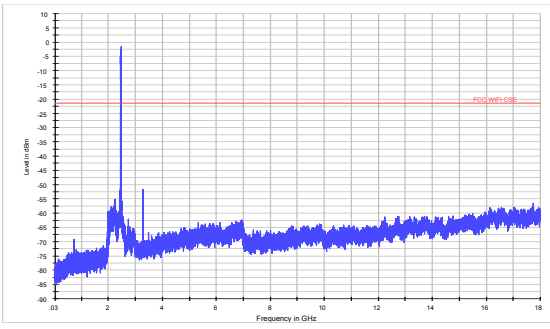

802.11n(HT20) CH11 18GHz to 26.5GHz

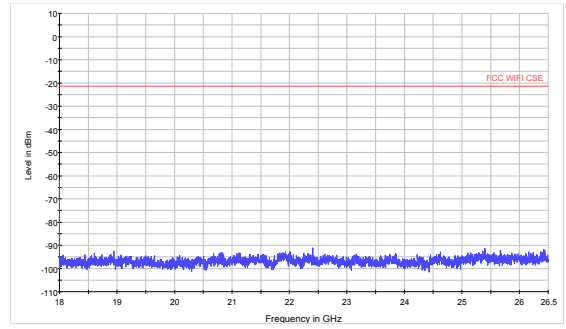

802.11n(HT40) CH3 30MHz to 18GHz

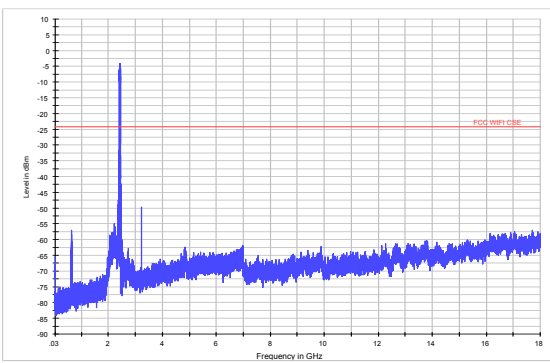

802.11n(HT40) CH3 18GHz to 26.5GHz

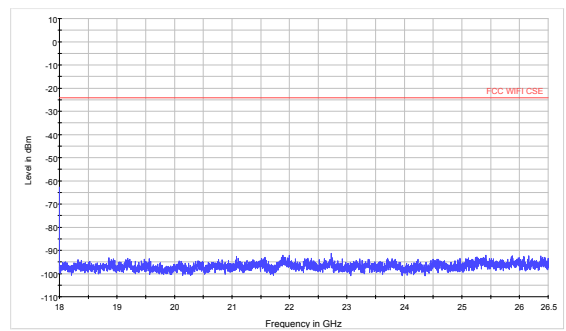

802.11n(HT40) CH6 30MHz to 18GHz

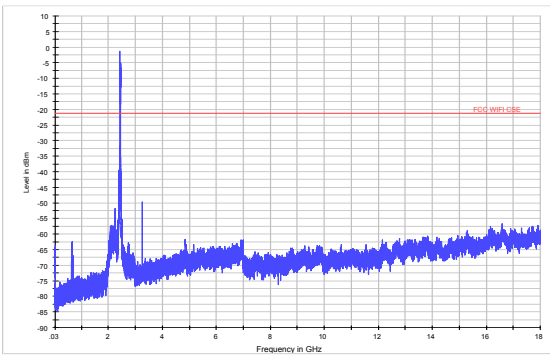

802.11n(HT40) CH6 18GHz to 26.5GHz

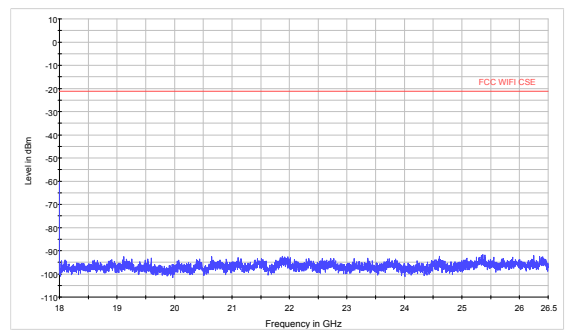

802.11n(HT40) CH9 30MHz to 18GHz

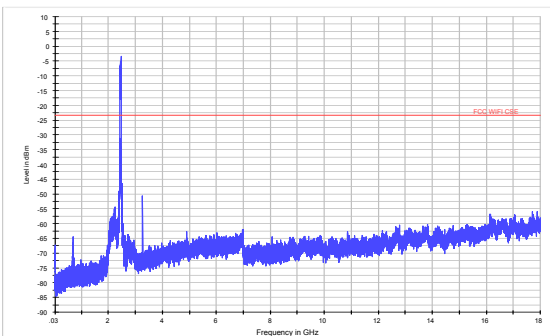

802.11n(HT40) CH9 18GHz to 26.5GHz

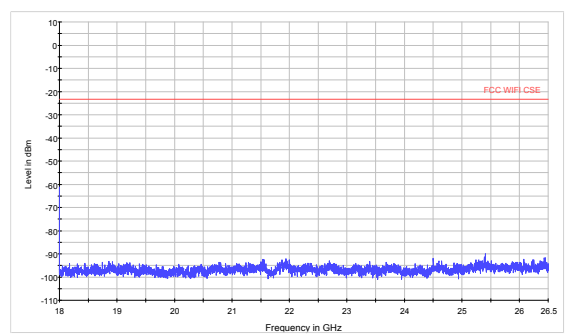





ANT2

802.11b CH1 30MHz to 18GHz

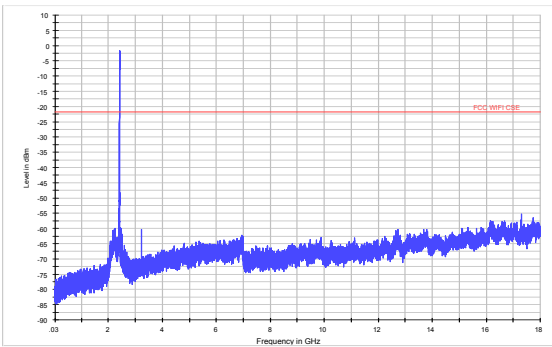

802.11b CH1 18GHz to 26.5GHz

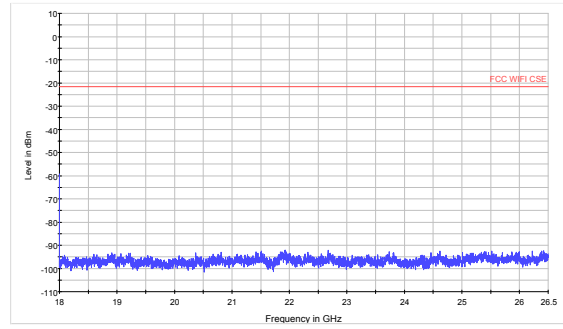

802.11b CH6 30MHz to 18GHz

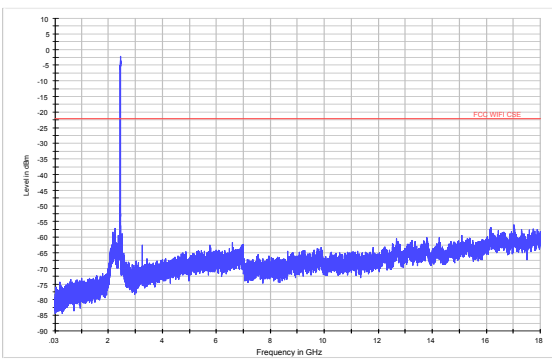

802.11b CH6 18GHz to 26.5GHz

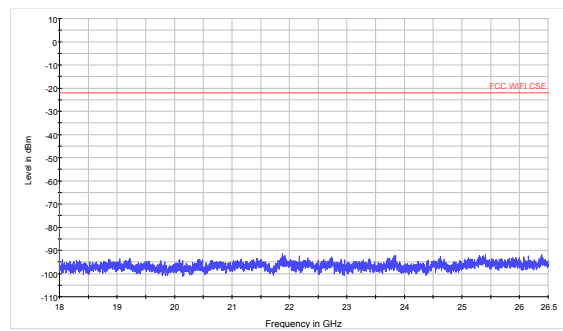

802.11b CH11 30MHz to 18GHz

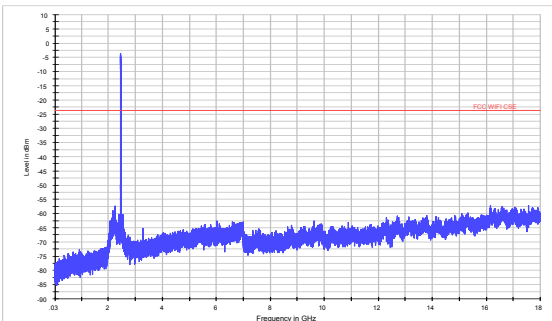

802.11b CH11 18GHz to 26.5GHz

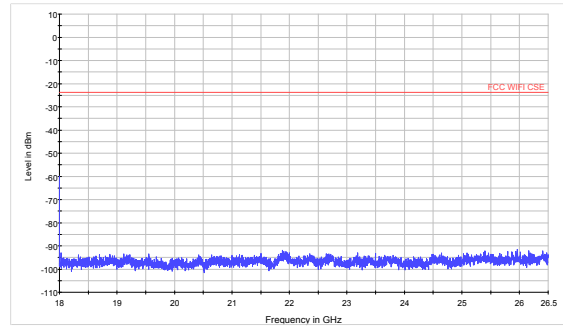

802.11g CH1 30MHz to 18GHz

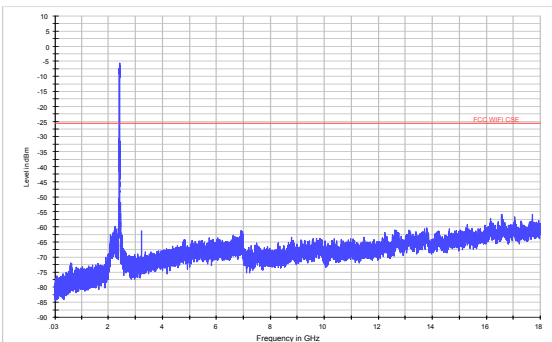

802.11g CH1 18GHz to 26.5GHz

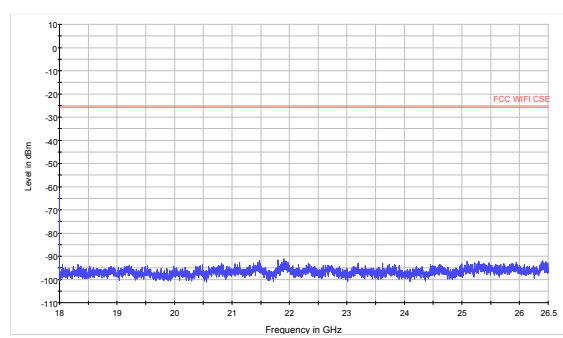

802.11g CH6 30MHz to 18GHz

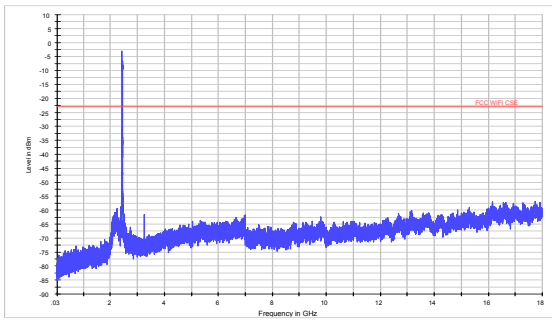

802.11g CH6 18GHz to 26.5GHz

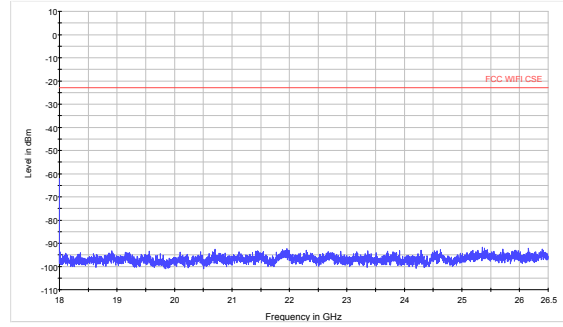

802.11g CH11 30MHz to 18GHz

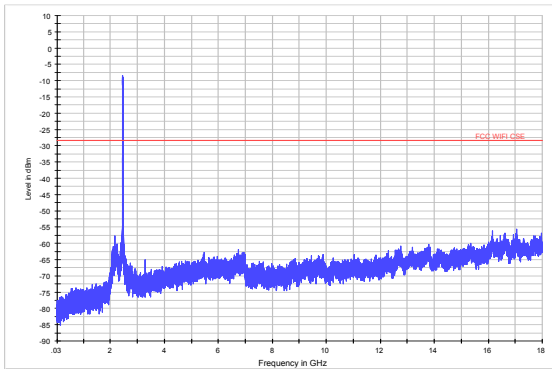

802.11g CH11 18GHz to 26.5GHz

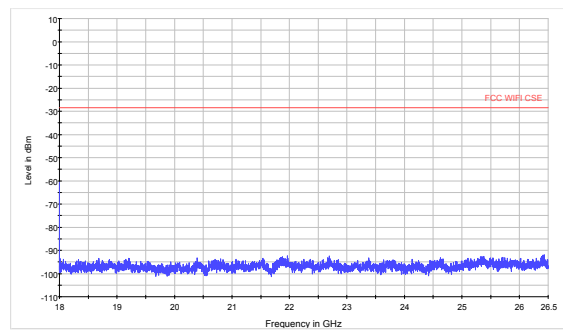

802.11n(HT20) CH1 30MHz to 18GHz

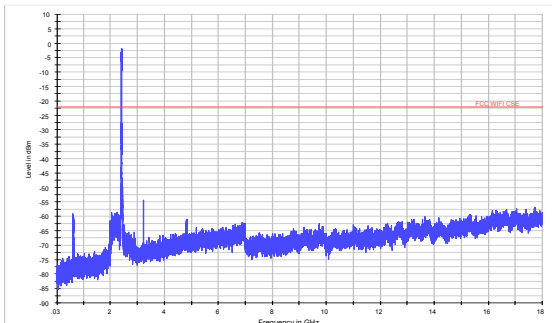

802.11n(HT20) CH1 18GHz to 26.5GHz

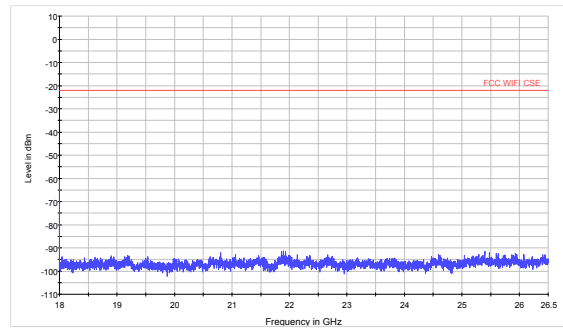

802.11n(HT20) CH6 30MHz to 18GHz

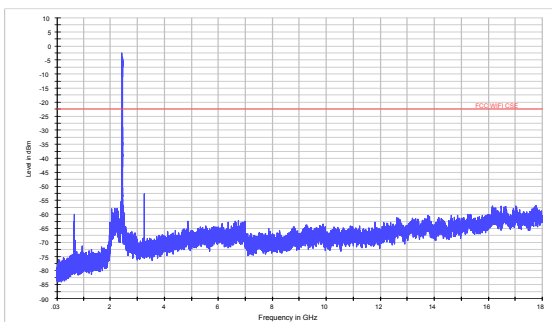

802.11n(HT20) CH6 18GHz to 26.5GHz

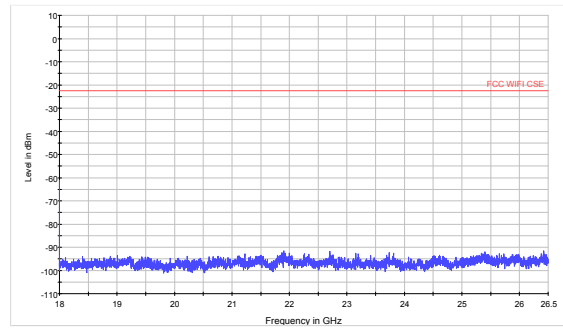

802.11n(HT20) CH11 30MHz to 18GHz

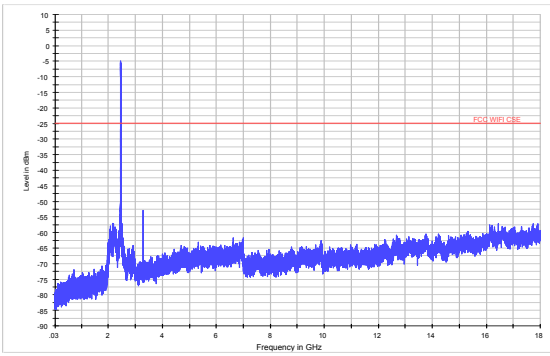

802.11n(HT20) CH11 18GHz to 26.5GHz

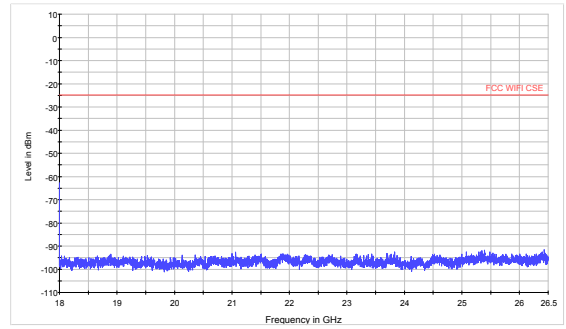

802.11n(HT40) CH3 30MHz to 18GHz

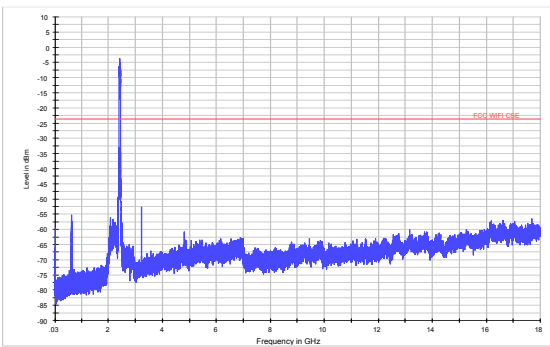

802.11n(HT40) CH3 18GHz to 26.5GHz

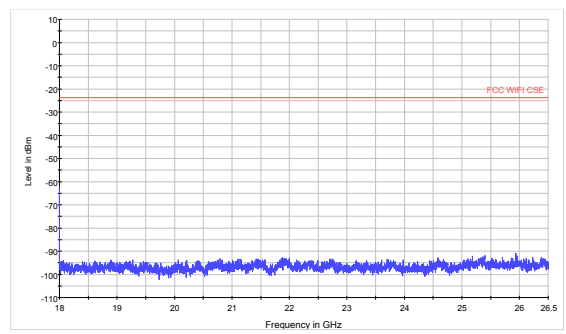

802.11n(HT40) CH6 30MHz to 18GHz

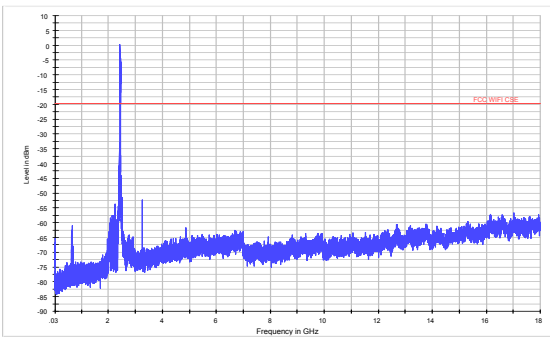

802.11n(HT40) CH6 18GHz to 26.5GHz

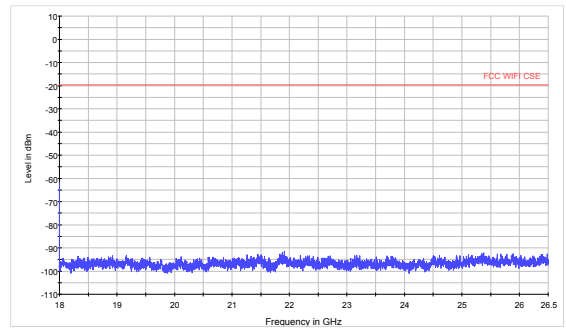

802.11n(HT40) CH9 30MHz to 18GHz

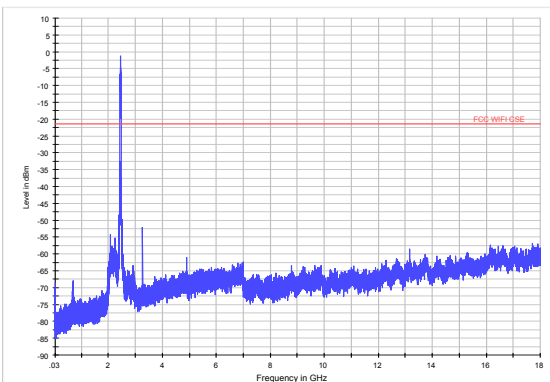

802.11n(HT40) CH9 18GHz to 26.5GHz

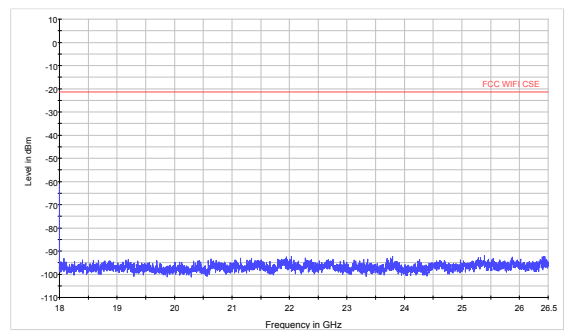



ANT3

802.11b CH1 30MHz to 18GHz

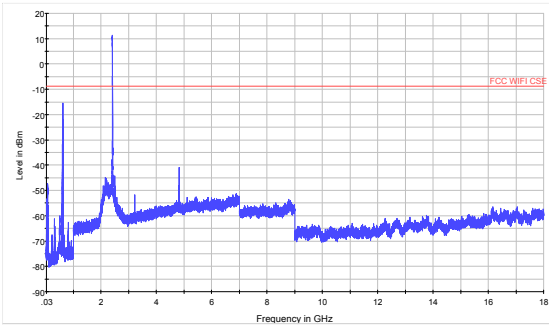

802.11b CH1 18GHz to 26.5GHz

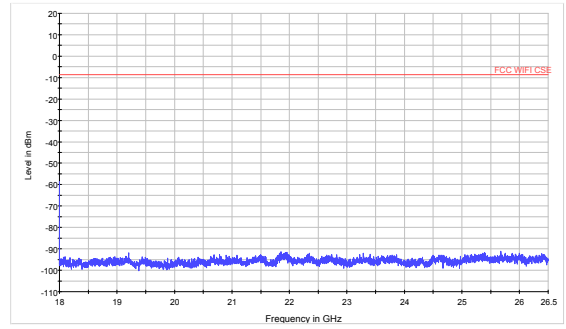

802.11b CH6 30MHz to 18GHz

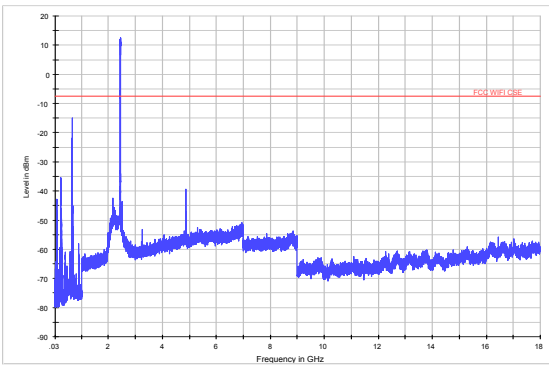

802.11b CH6 18GHz to 26.5GHz

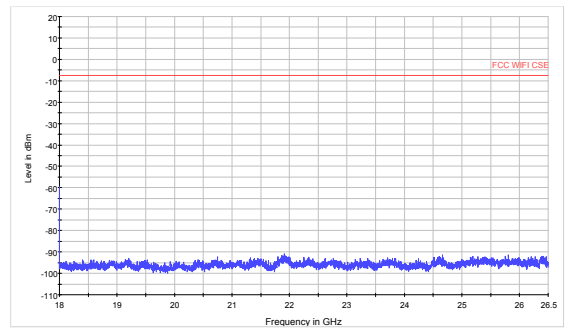

802.11b CH11 30MHz to 18GHz

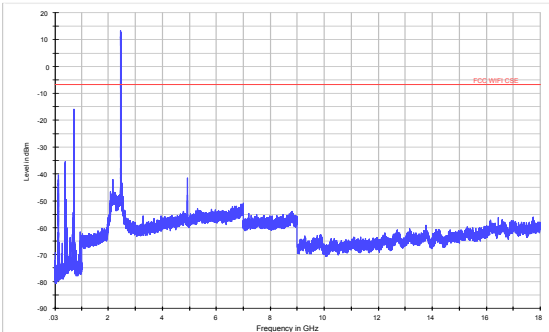

802.11b CH11 18GHz to 26.5GHz

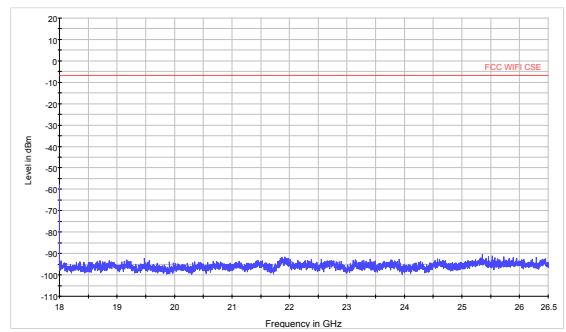

802.11g CH1 30MHz to 18GHz

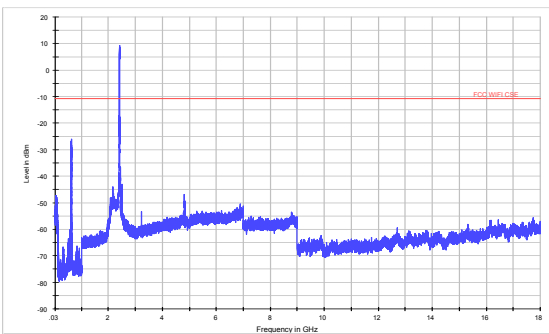

802.11g CH1 18GHz to 26.5GHz

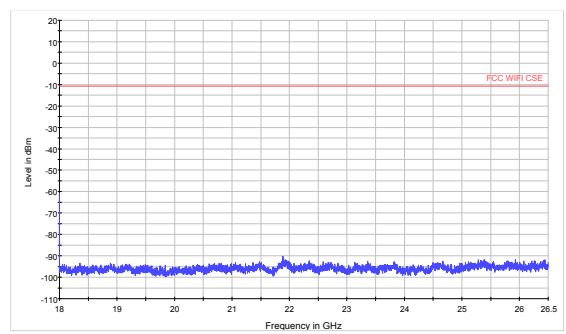



802.11g CH6 30MHz to 18GHz

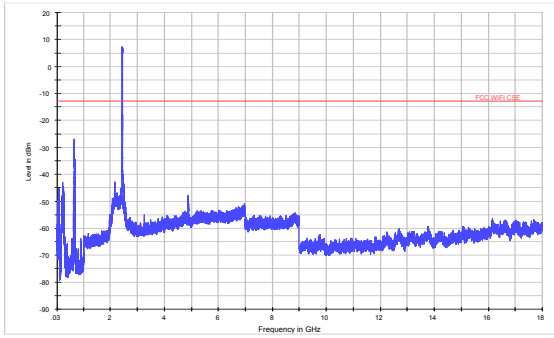

802.11g CH6 18GHz to 26.5GHz

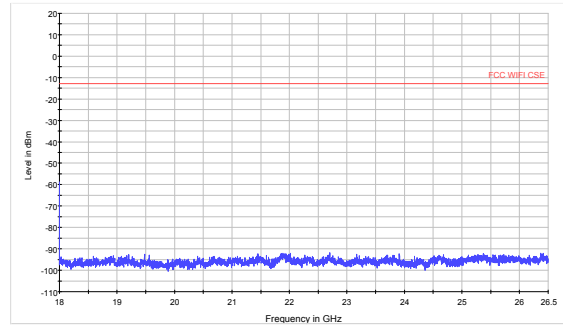

802.11g CH11 30MHz to 18GHz

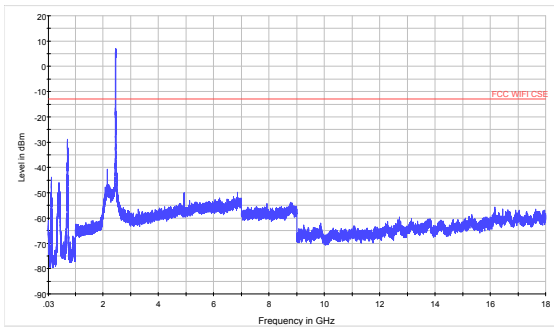

802.11g CH11 18GHz to 26.5GHz

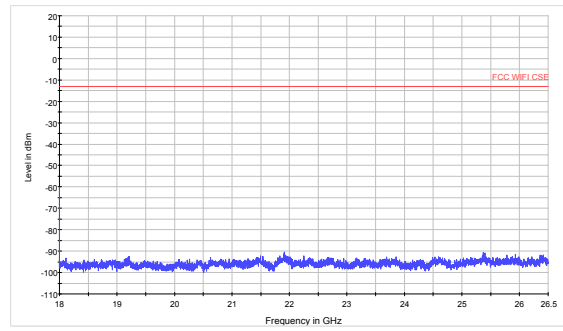

802.11n(HT20) CH1 30MHz to 18GHz

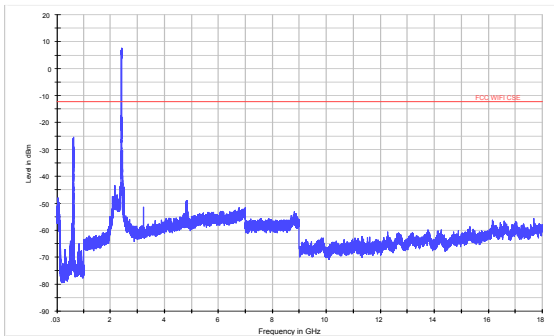

802.11n(HT20) CH1 18GHz to 26.5GHz

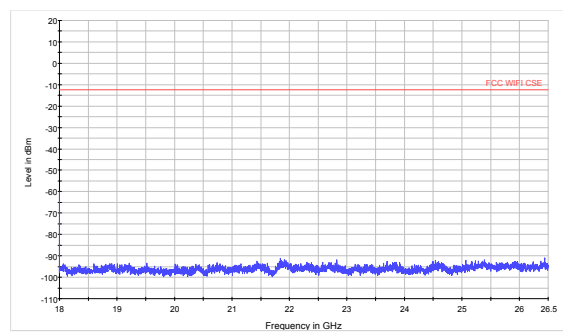

802.11n(HT20) CH6 30MHz to 18GHz

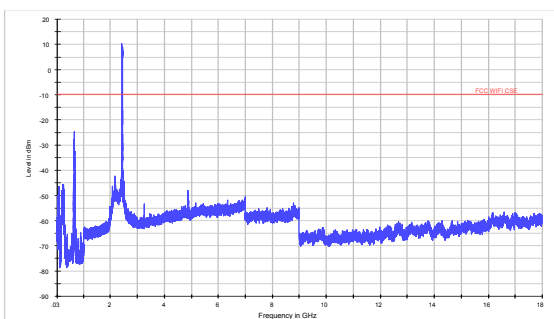

802.11n(HT20) CH6 18GHz to 26.5GHz

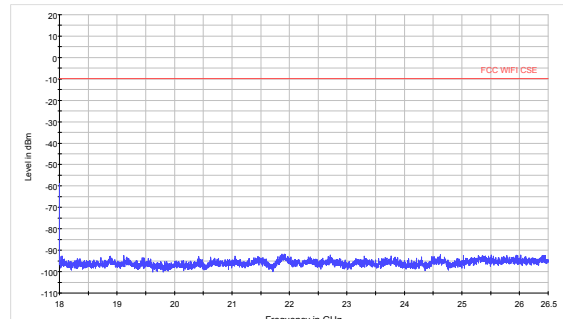



802.11n(HT20) CH11 30MHz to 18GHz

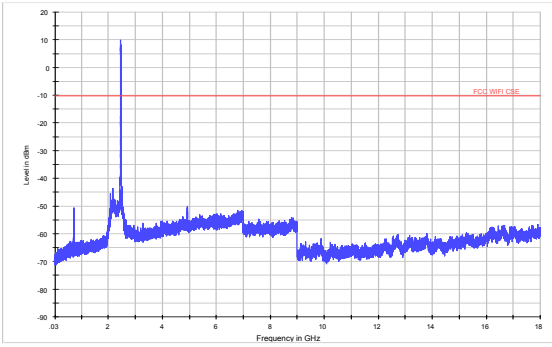

802.11n(HT20) CH11 18GHz to 26.5GHz

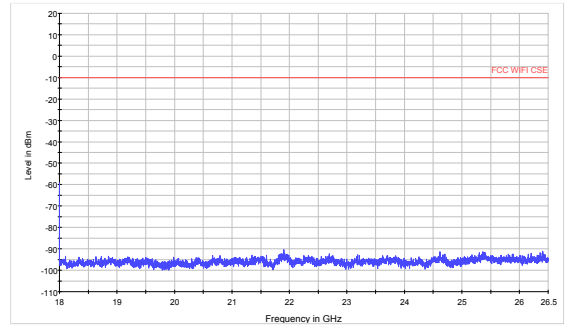

802.11n(HT40) CH3 30MHz to 18GHz

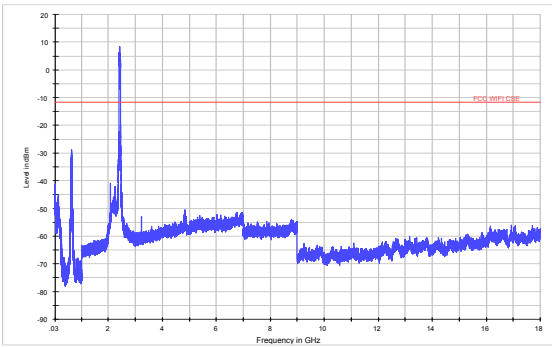

802.11n(HT40) CH3 18GHz to 26.5GHz

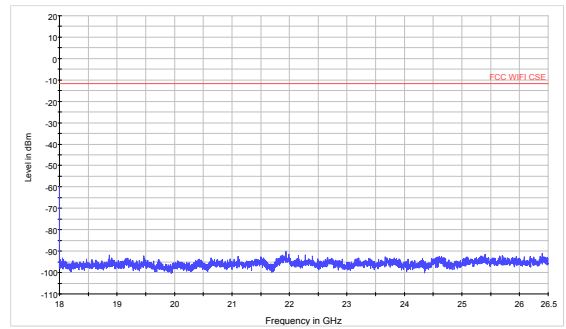

802.11n(HT40) CH6 30MHz to 18GHz

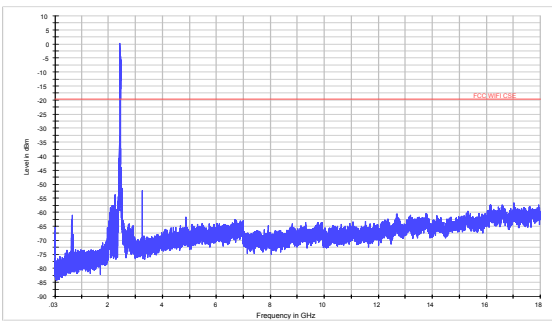

802.11n(HT40) CH6 18GHz to 26.5GHz

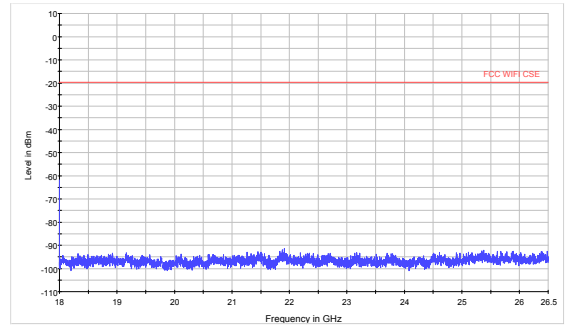

802.11n(HT40) CH9 30MHz to 18GHz

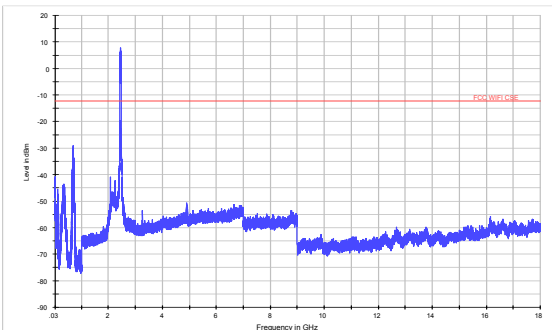

802.11n(HT40) CH9 18GHz to 26.5GHz

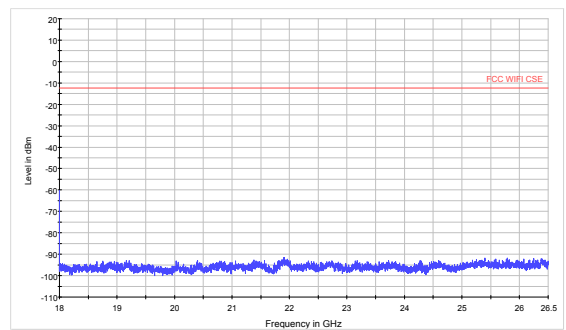

MIMO

802.11n(HT20) CH1 30MHz to 18GHz

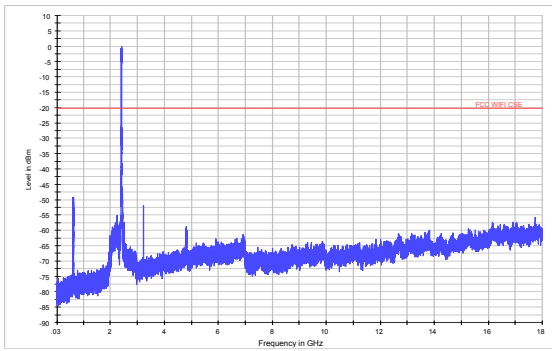

802.11n(HT20) CH1 18GHz to 26.5GHz

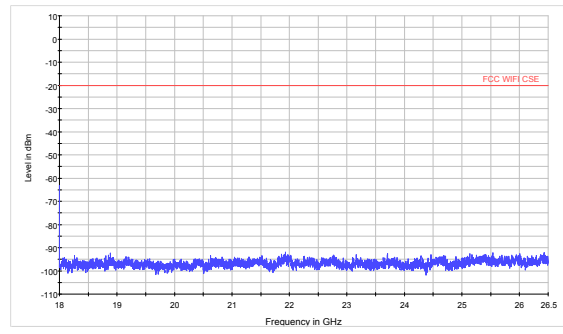

802.11n(HT20) CH6 30MHz to 18GHz

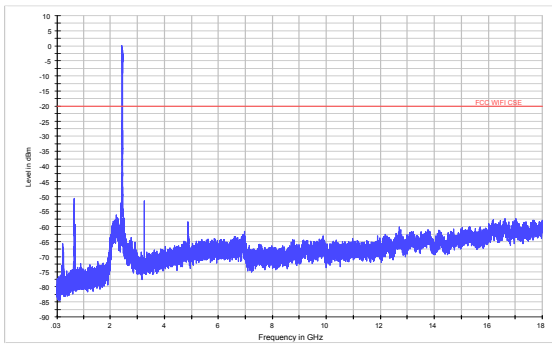

802.11n(HT20) CH6 18GHz to 26.5GHz

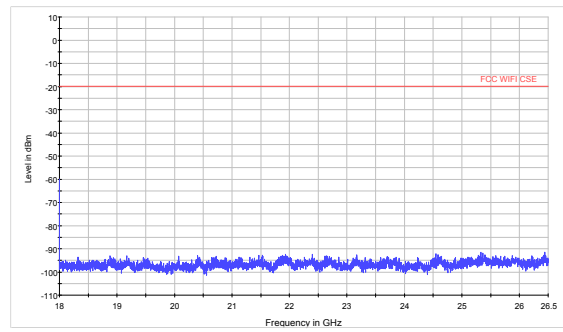

802.11n(HT20) CH11 30MHz to 18GHz

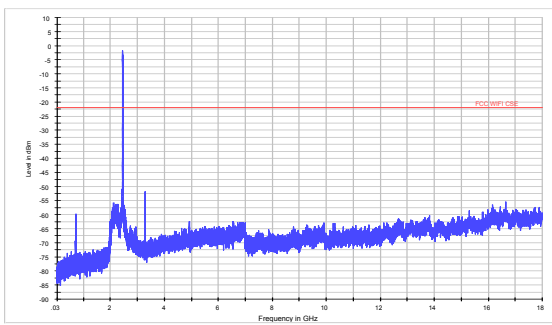

802.11n(HT20) CH11 18GHz to 26.5GHz

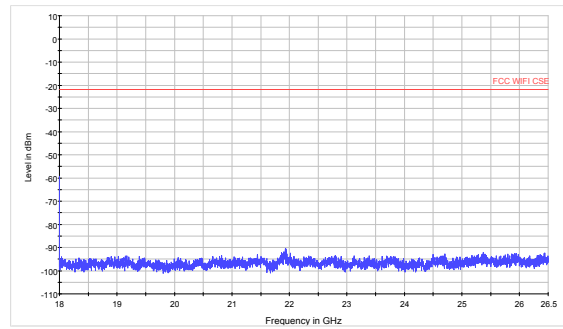

802.11n(HT40) CH3 30MHz to 18GHz

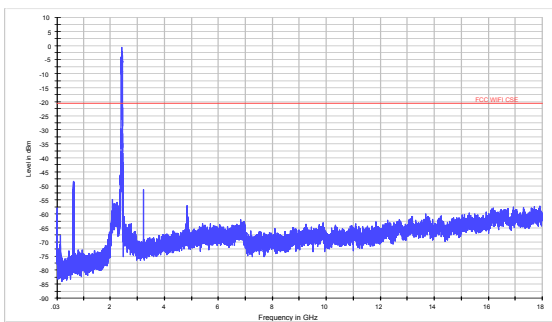

802.11n(HT40) CH3 18GHz to 26.5GHz

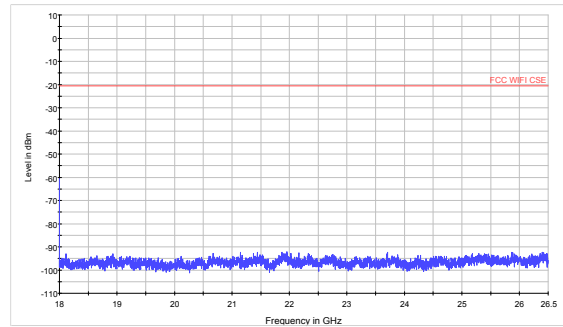



802.11n(HT40) CH6 30MHz to 18GHz

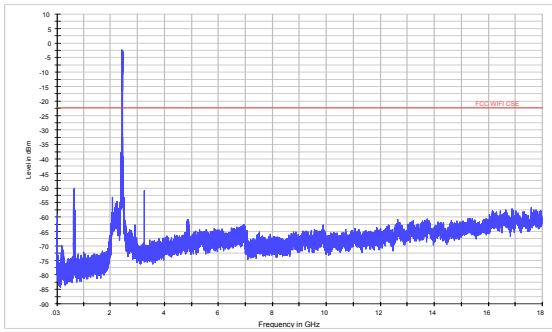

802.11n(HT40) CH6 18GHz to 26.5GHz

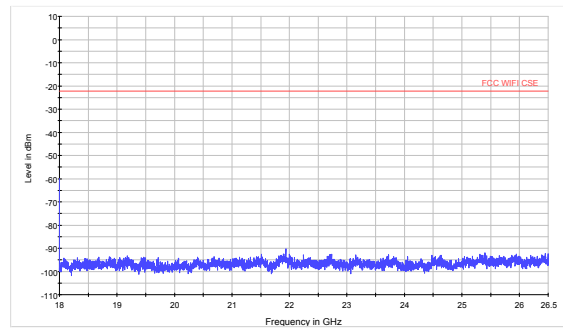

802.11n(HT40) CH9 30MHz to 18GHz

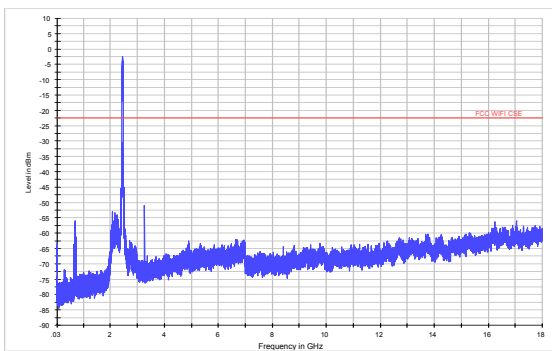

802.11n(HT40) CH9 18GHz to 26.5GHz

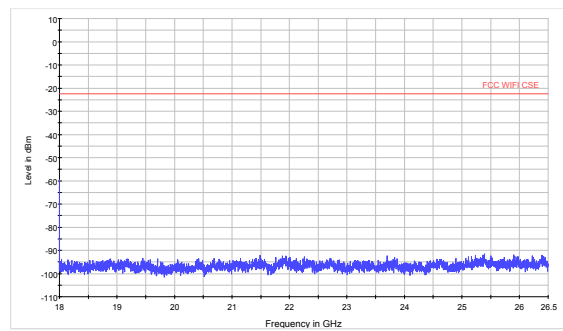



Zigbee CH11 30MHz to 18GHz

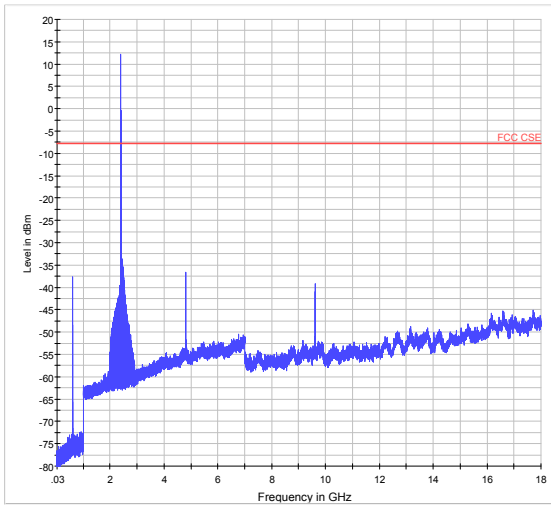

Zigbee CH11 18GHz to 26.5GHz

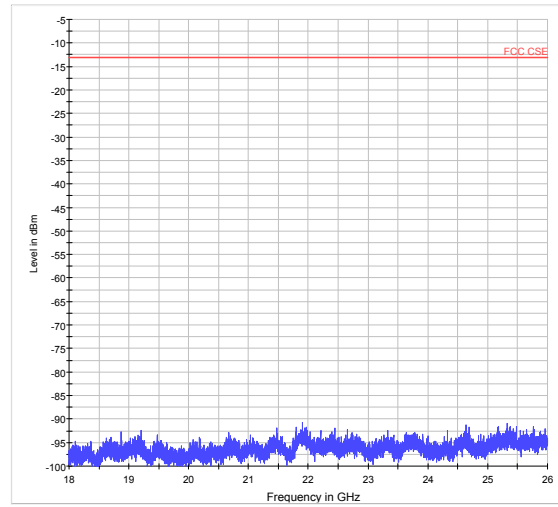

Zigbee CH18 30MHz to 18GHz

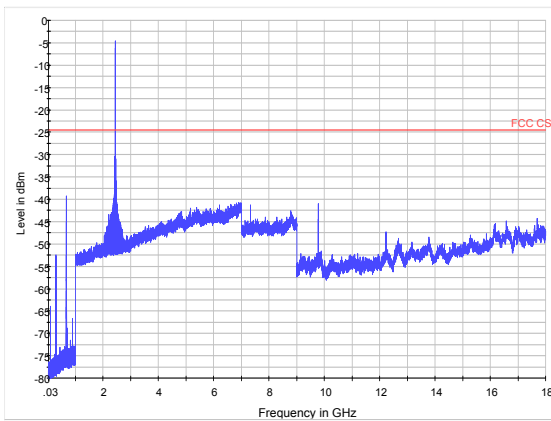

Zigbee CH18 18GHz to 26.5GHz

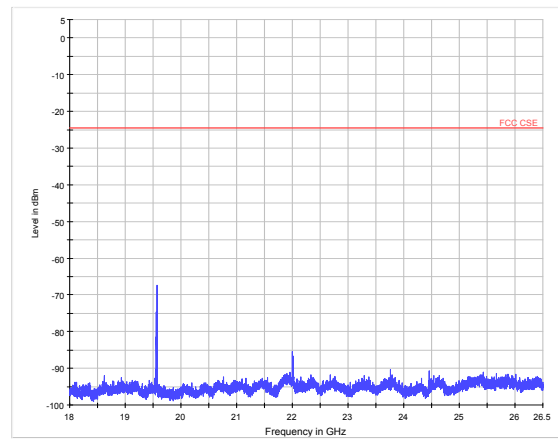

Zigbee CH25 30MHz to 18GHz

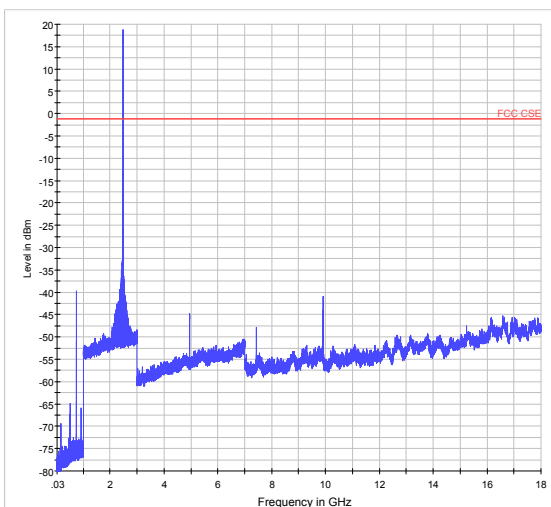

Zigbee CH25 18GHz to 26.5GHz

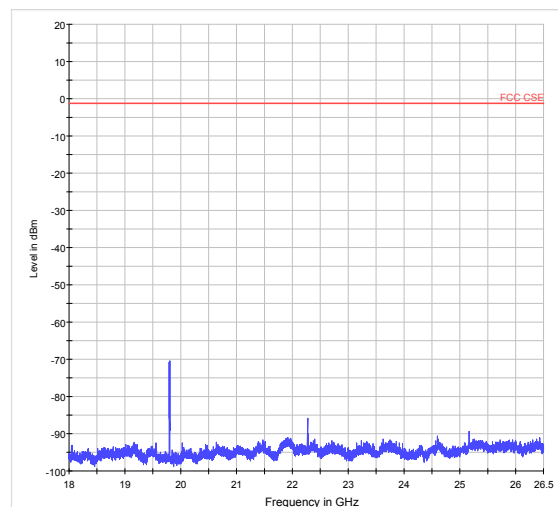

### 5.6. Radiated Emissions in the Restricted Band

#### Ambient condition

Temperature	Relative humidity	Pressure
23°C ~25°C	45%~50%	101.5kPa

#### Method of Measurement

The Equipment Under Test (EUT) was set up on a non-conductive table in the semi-anechoic chamber. The test was performed at the distance of 3 m between the EUT and the receiving antenna. The turntable shall be rotated from 0 to 360 degrees for detecting the maximum of radiated spurious signal level. The measurements shall be repeated with orthogonal polarization of the test antenna. RBW is set to 100kHz. The data of cable loss and antenna factor has been calibrated in full testing frequency range before the testing. Sweep the whole frequency band through the range from 9kHz to the 10th harmonic of the carrier, and the emissions less than 20 dB below the permissible value are reported.

Set the spectrum analyzer in the following:

- (a) PEAK: RBW=VBW=3MHz / Sweep=AUTO
- (b) AVERAGE: RBW=1MHz / VBW=3MHz / Sweep=AUTO

This setting method can refer to **KDB 558074**.

The field strength of spurious emission was measured in the following position: EUT stand-up position (Z axis), lie-down position (X, Y axis). The worst emission was found in stand-up position (Y axis) and the antenna is vertical.

The test is in transmitting mode.

#### Test setup

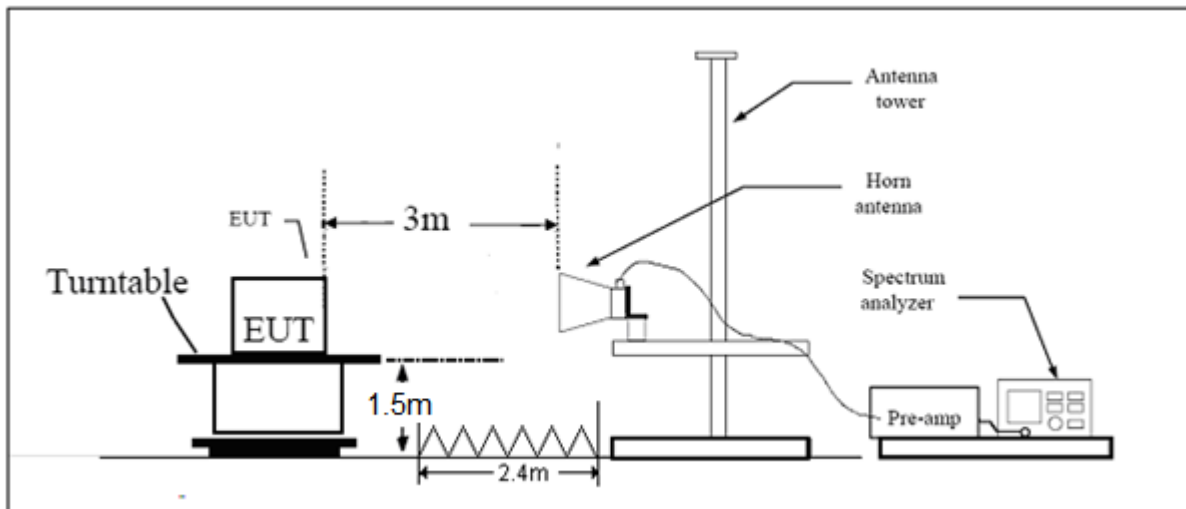

Note: Area side: 2.4mX3.6m

**Limits**

Spurious Radiated Emissions are permitted in any of the frequency bands listed below:

MHz	MHz	MHz	GHz
0.090 - 0.110	16.42 - 16.423	399.9 - 410	4.5 - 5.15
<sup>1</sup> 0.495 - 0.505	16.69475 - 16.69525	608 - 614	5.35 - 5.46
2.1735 - 2.1905	16.80425 - 16.80475	960 - 1240	7.25 - 7.75
4.125 - 4.128	25.5 - 25.67	1300 - 1427	8.025 - 8.5
4.17725 - 4.17775	37.5 - 38.25	1435 - 1626.5	9.0 - 9.2
4.20725 - 4.20775	73 - 74.6	1645.5 - 1646.5	9.3 - 9.5
6.215 - 6.218	74.8 - 75.2	1660 - 1710	10.6 - 12.7
6.26775 - 6.26825	108 - 121.94	1718.8 - 1722.2	13.25 - 13.4
6.31175 - 6.31225	123 - 138	2200 - 2300	14.47 - 14.5
8.291 - 8.294	149.9 - 150.05	2310 - 2390	15.35 - 16.2
8.362 - 8.366	156.52475 - 156.52525	2483.5 - 2500	17.7 - 21.4
8.37625 - 8.38675	156.7 - 156.9	2690 - 2900	22.01 - 23.12
8.41425 - 8.41475	162.0125 - 167.17	3260 - 3267	23.6 - 24.0
12.29 - 12.293	167.72 - 173.2	3332 - 3339	31.2 - 31.8
12.51975 - 12.52025	240 - 285	3345.8 - 3358	36.43 - 36.5
12.57675 - 12.57725	322 - 335.4	3600 - 4400	( <sup>2</sup> )
13.36 - 13.41			

Limit in restricted band

Frequency of emission (MHz)	Field strength(uV/m)	Field strength(dBuV/m)
30-88	100	40
88-216	150	43.5
216-960	200	46
Above960	500	54

§15.35(b)

There is also a limit on the radio frequency emissions, as measured using instrumentation with a peak detector function, corresponding to 20 dB above the maximum permitted average limit.

Peak Limit=74 dBuV/m

Average Limit=54 dBuV/m

**Measurement Uncertainty**

The assessed measurement uncertainty to ensure 95% confidence level for the normal distribution is with the coverage factor  $k = 1.96$ ,  $U = 3.55$  dB.



**Test Results:**

**PASS**

The signal beyond the limit is carrier.

**802.11b-Channel 1: Peak**

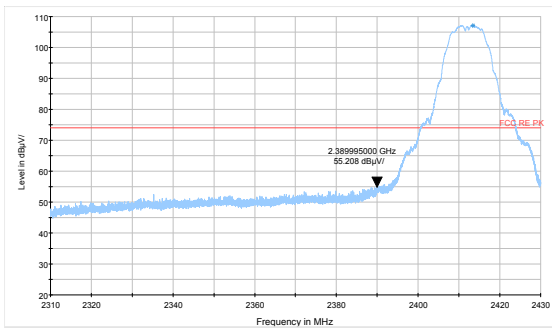

**802.11b-Channel 1: Average**

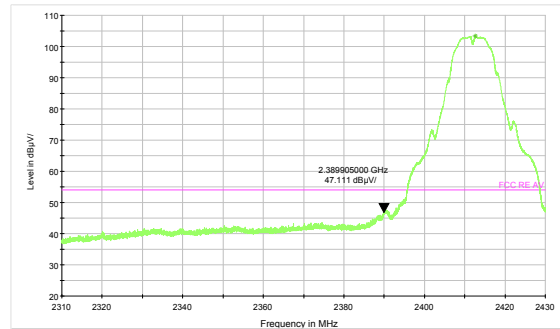

**802.11b-Channel 11: Peak**

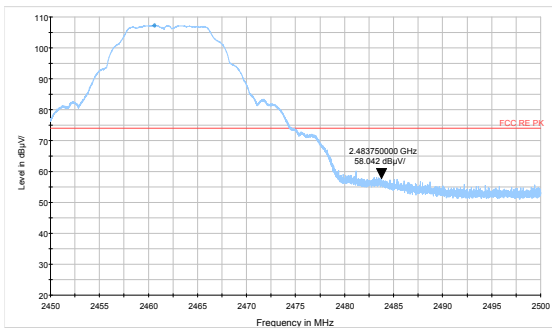

**802.11b-Channel 11: Average**

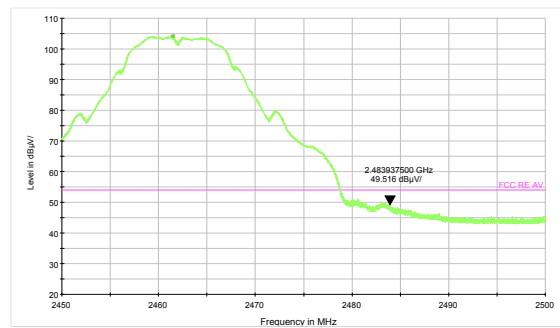

**802.11g-Channel 1: Peak**

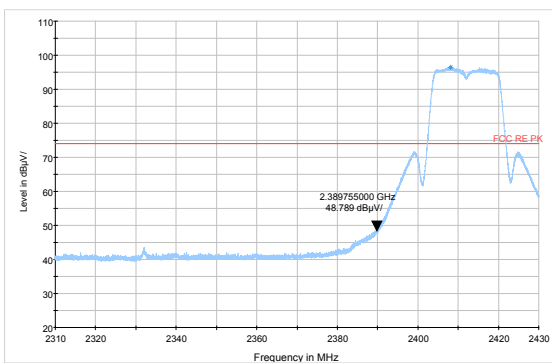

**802.11g-Channel 1: Average**

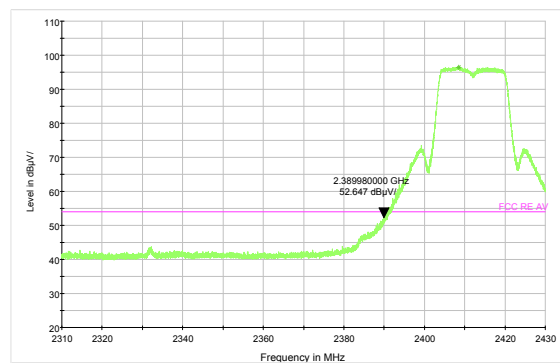

**802.11g-Channel 11: Peak**

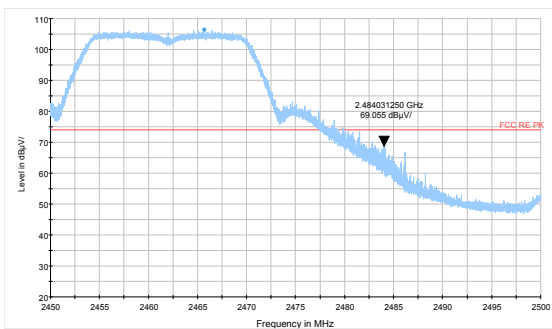

**802.11g-Channel 11: Average**

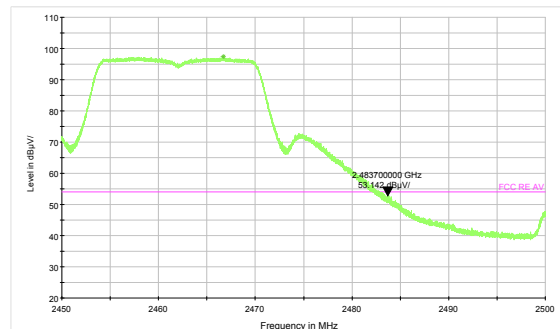



### 802.11n HT20 -Channel 1: Peak

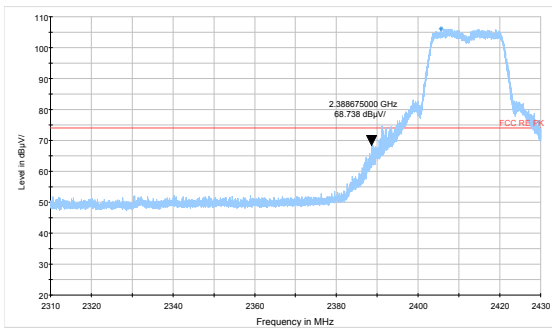

### 802.11n HT20-Channel 1: Average

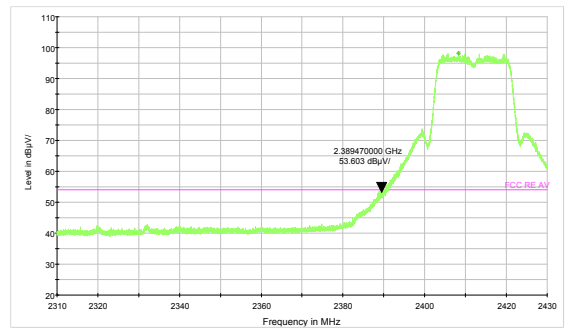

### 802.11n HT20-Channel 11: Peak

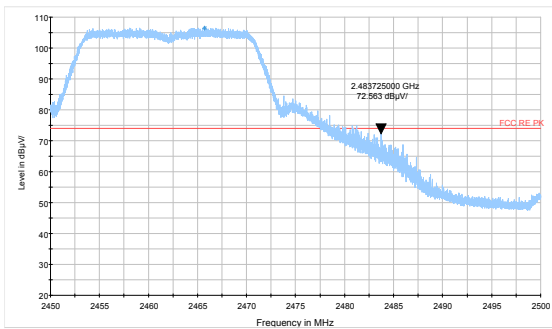

### 802.11n HT20-Channel 11: Average

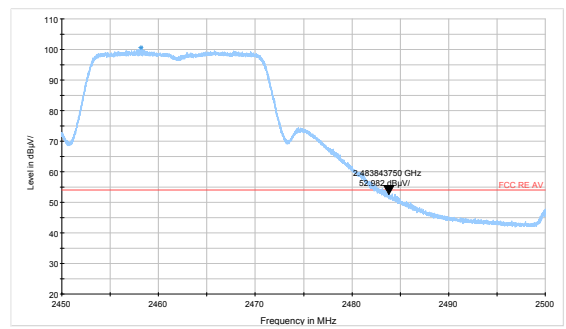

### 802.11n HT40 -Channel 3: Peak

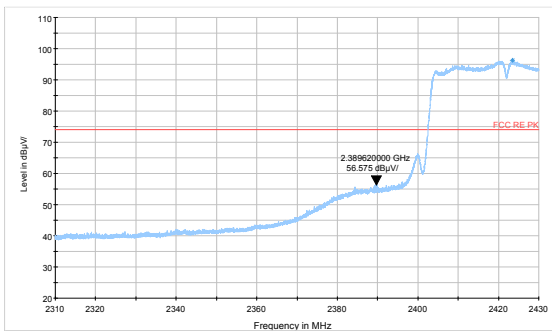

### 802.11n HT40-Channel 3: Average

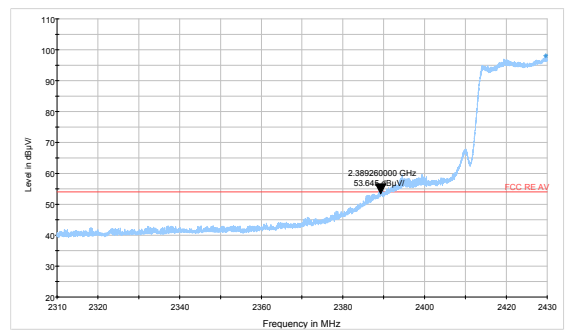

### 802.11n HT40-Channel 9: Peak

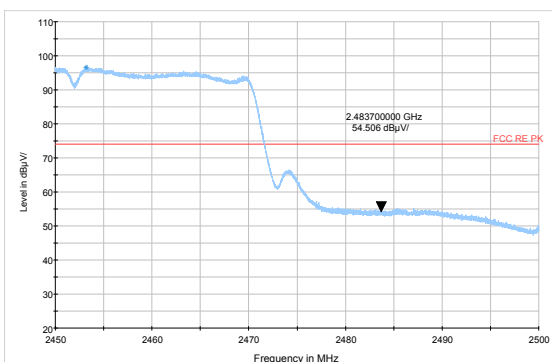

### 802.11n HT40-Channel 9: Average

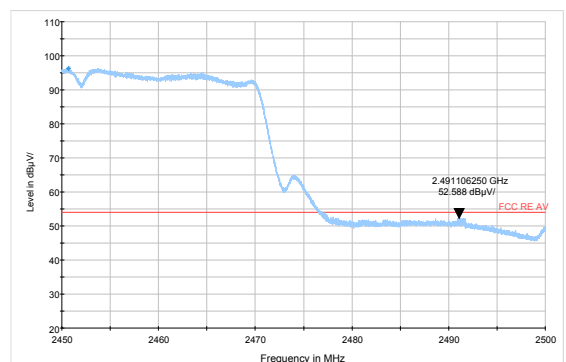

**Zigbee-Channel 11: Peak**

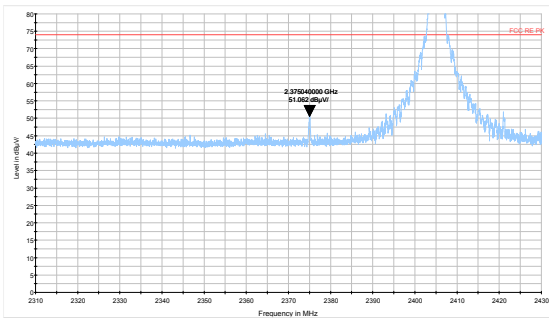

**Zigbee-Channel 11: Average**

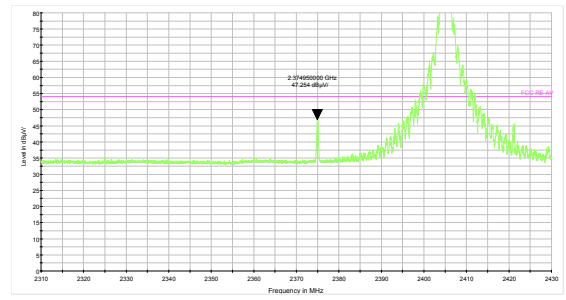

**Zigbee-Channel 25: Peak**

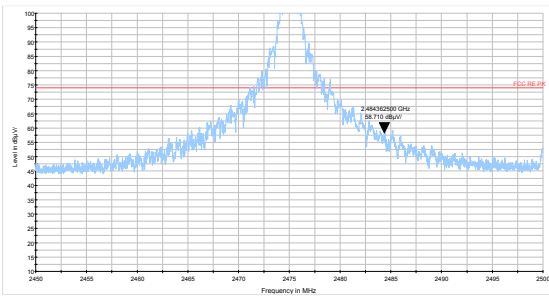

**Zigbee-Channel 25: Average**

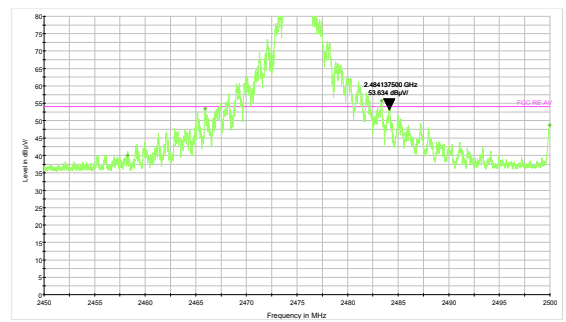

## 5.7. Radiates Emission

### Ambient condition

Temperature	Relative humidity	Pressure
23°C ~25°C	45%~50%	102.5kPa

### Method of Measurement

The test set-up was made in accordance to the general provisions of ANSI C63.10-2013. The Equipment Under Test (EUT) was set up on a non-conductive table in the semi-anechoic chamber. The test was performed at the distance of 3 m between the EUT and the receiving antenna. The radiated emissions measurements were made in a typical installation configuration.

Sweep the whole frequency band through the range from 9 kHz to the 10th harmonic of the carrier, and the emissions less than 20 dB below the permissible value are reported.

During the test, below 30MHz, the center of the loop shall be 1 meters; above 30MHz, the height of receive antenna shall be moved from 1 to 4 meters, and the antenna shall be performed under horizontal and vertical polarization. The turntable shall be rotated from 0 to 360 degrees for detecting the maximum of radiated spurious signal level. The measurements shall be repeated with orthogonal polarization of the test antenna. The data of cable loss and antenna factor has been calibrated in full testing frequency range before the testing.

Set the spectrum analyzer in the following:

Below 1GHz (detector: Peak and Quasi-Peak)

RBW=100 kHz / VBW=300 kHz / Sweep=AUTO

Above 1GHz (detector: Peak):

(a) PEAK: RBW=1MHz VBW=3MHz/ Sweep=AUTO

(b) AVERAGE: RBW=1MHz / VBW=3MHz / Sweep=AUTO

The radiated emission was measured in the following position: EUT stand-up position (Z axis), lie-down position (X, Y axis). The worst emission was found in stand-up position (Z axis) and the worst case was recorded.

The test is in transmitting mode.

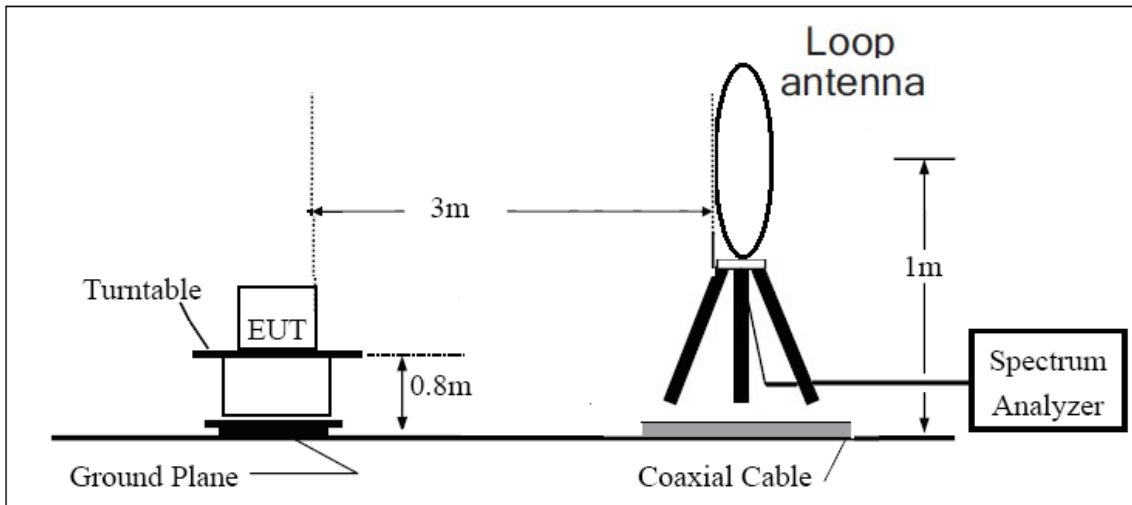
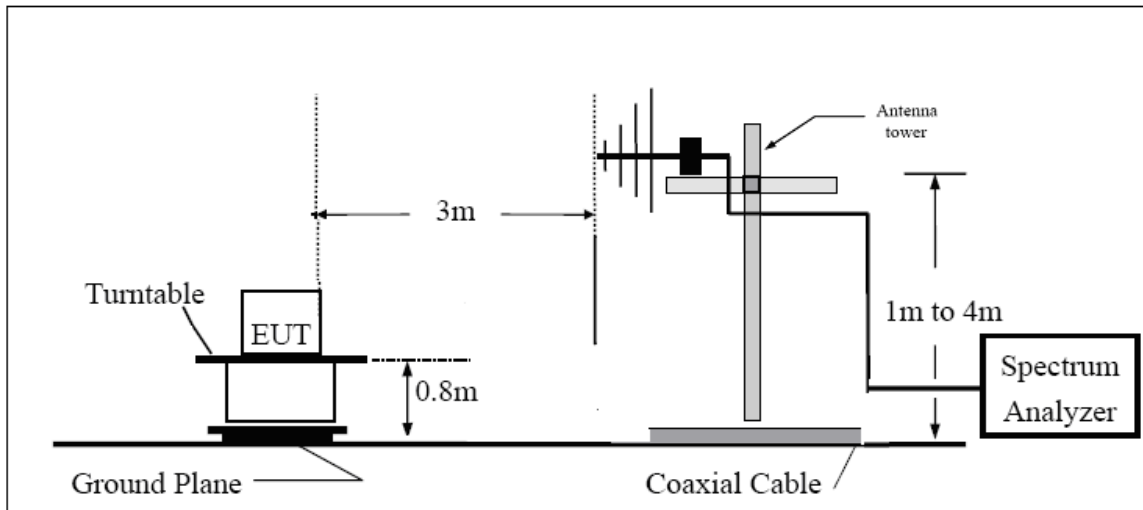
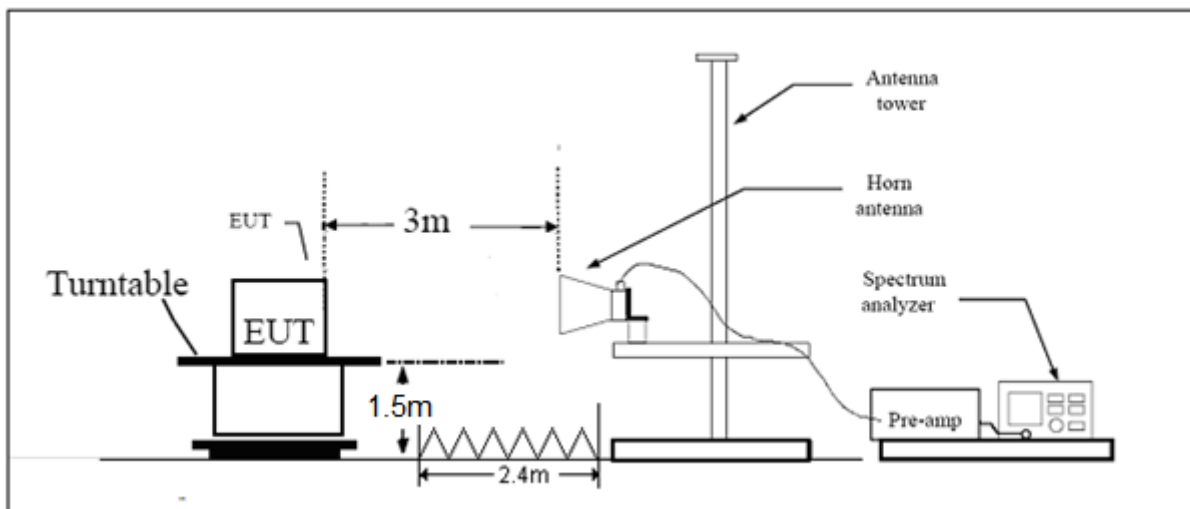
**Test setup****9KHz~~~ 30MHz****30MHz~~~ 1GHz****Above 1GHz**

Note: Area side:2.4mX3.6m



**Limits**

Rule Part 15.247(d) specifies that “In addition, radiated emissions which fall in the restricted bands, as defined in § 15.205(a), must also comply with the radiated emission limits specified in § 15.209(a) (see § 15.205(c)).”

Limit in restricted band

Frequency of emission (MHz)	Field strength(uV/m)	Field strength(dBuV/m)
0.009–0.490	2400/F(kHz)	/
0.490–1.705	24000/F(kHz)	/
1.705–30.0	30	/
30-88	100	40
88-216	150	43.5
216-960	200	46
Above960	500	54

§15.35(b)

There is also a limit on the radio frequency emissions, as measured using instrumentation with a peak detector function, corresponding to 20 dB above the maximum permitted average limit.

**Measurement Uncertainty**

The assessed measurement uncertainty to ensure 95% confidence level for the normal distribution is with the coverage factor  $k = 1.96$ .

Frequency	Uncertainty
9KHz-30MHz	3.55 dB
30MHz-200MHz	4.19 dB
200MHz-1GHz	3.63 dB
Above 1GHz	3.68 dB



**Test result**

Sweep from 9 kHz to 30MHz, and the emissions more than 20 dB below the permissible value are not reported.

The following graphs display the maximum values of horizontal and vertical by software.

For above 1GHz, Blue trace uses the peak detection, Green trace uses the average detection.

**802.11b CH1**

FCC RE 0.03-1GHz QP Class B

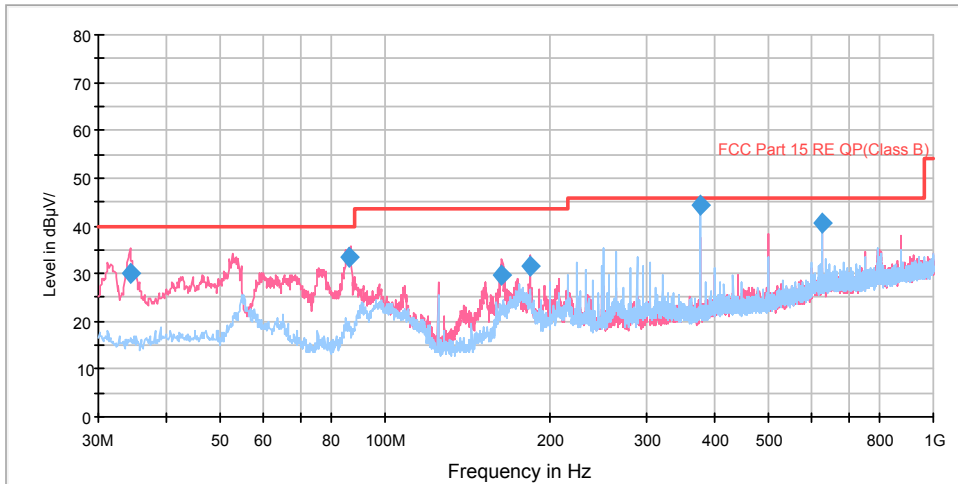

Radiates Emission from 30MHz to 1GHz

Frequency (MHz)	Quasi-Peak (dBuV/m)	Height (cm)	Polarization	Azimuth (deg)	Reading value (dBuV/m)	Correct Factor (dB)	Margin (dB)	Limit (dBuV/m)
34.403750	29.9	100.0	V	246.0	41.8	11.9	10.1	40.0
86.103750	33.5	125.0	V	284.0	44.1	10.6	6.5	40.0
163.537500	29.7	100.0	V	41.0	39.6	9.9	13.8	43.5
184.270000	31.5	125.0	V	0.0	42.6	11.1	12.0	43.5
374.996250	44.2	100.0	H	175.0	61.6	17.4	1.8	46.0
625.015000	40.7	114.0	H	0.0	62.9	22.2	5.3	46.0

**Remark: 1. Quasi-Peak = Reading value + Correction factor**

**2. Correction Factor = Antenna factor+ Insertion loss(cable loss+amplifier gain)**

**3. Margin = Limit – Quasi-Peak**

RE 1G-3GHz PK+AV

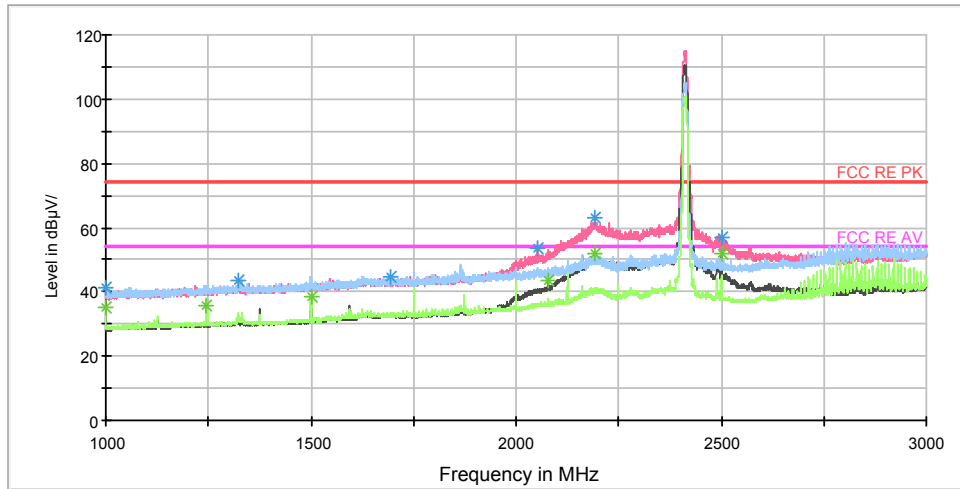

Note: The signal beyond the limit is carrier.

Radiates Emission from 1GHz to 3GHz

Frequency (MHz)	Peak (dBuV/m)	Height (cm)	Polarization	Azimuth (deg)	Reading value (dBuV/m)	Correct Factor (dB)	Margin (dB)	Limit (dBuV/m)
1000.000000	41.5	301.0	H	154.0	50.7	-9.2	32.5	74
1244.250000	41.6	301.0	H	139.0	49.6	-8.0	32.4	74
1500.000000	44.1	202.0	H	257.0	50.8	-6.7	29.9	74
2080.000000	52.1	301.0	V	0.0	55.1	-3.0	21.9	74
2191.750000	61.3	201.0	V	5.0	63.4	-2.1	12.7	74
2500.000000	57.0	201.0	V	173.0	57.2	-0.2	17.0	74

Remark: 1. Correction Factor = Antenna factor+ Insertion loss (cable loss + amplifier gain)

Frequency (MHz)	Average (dBuV/m)	Height (cm)	Polarization	Azimuth (deg)	Reading value (dBuV/m)	Correct Factor (dB)	Margin (dB)	Limit (dBuV/m)
1000.000000	35.2	301.0	H	154.0	44.4	-9.2	18.8	54
1244.250000	35.6	301.0	H	139.0	43.6	-8.0	18.4	54
1500.000000	38.7	202.0	H	257.0	45.4	-6.7	15.3	54
2080.000000	43.4	301.0	V	0.0	46.4	-3.0	10.6	54
2191.750000	51.7	201.0	V	5.0	53.8	-2.1	2.3	54
2500.000000	51.8	201.0	V	173.0	52.0	-0.2	2.2	54

Remark: 1. Correction Factor = Antenna factor+ Insertion loss (cable loss + amplifier gain)

RE 3-18GHz PK+AV

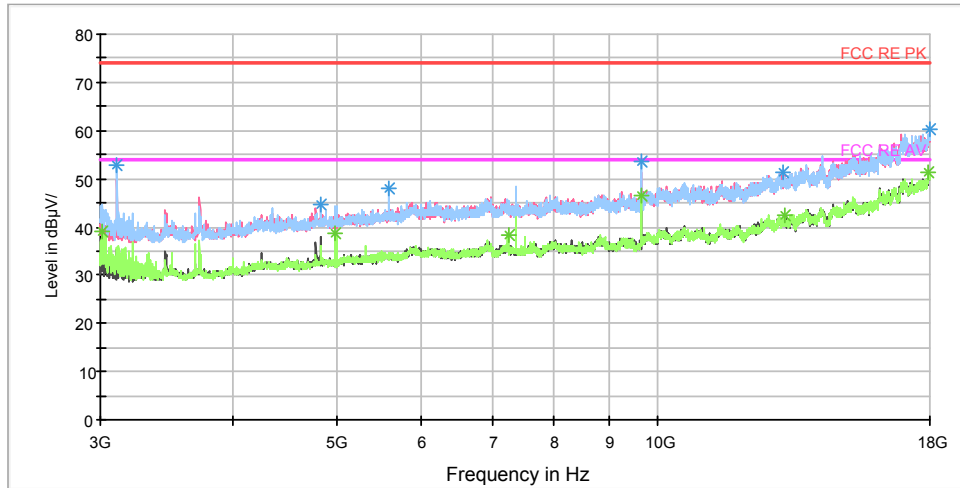

Radiates Emission from 3GHz to 18GHz

Frequency (MHz)	Peak (dBuV/m)	Height (cm)	Polarization	Azimuth (deg)	Reading value (dBuV/m)	Correct Factor (dB)	Margin (dB)	Limit (dBuV/m)
3016.875000	44.5	201.0	H	140.0	46.4	-1.9	29.5	74
4976.250000	44.3	201.0	H	256.0	47.3	3.0	29.7	74
7237.500000	45.2	201.0	H	91.0	53.9	8.7	28.8	74
9648.750000	53.7	201.0	H	140.0	64.2	10.5	20.3	74
13160.625000	50.6	202.0	V	53.0	66.0	15.4	23.4	74
17945.625000	57.7	201.0	H	40.0	82.5	24.8	16.3	74

Remark: 1. Correction Factor = Antenna factor+ Insertion loss (cable loss + amplifier gain)

Frequency (MHz)	Average (dBuV/m)	Height (cm)	Polarization	Azimuth (deg)	Reading value (dBuV/m)	Correct Factor (dB)	Margin (dB)	Limit (dBuV/m)
3016.875000	39.1	201.0	H	140.0	41.0	-1.9	14.9	54
4976.250000	38.9	201.0	H	256.0	41.9	3.0	15.1	54
7237.500000	38.4	201.0	H	91.0	47.1	8.7	15.6	54
9648.750000	46.6	201.0	H	140.0	57.1	10.5	7.4	54
13160.625000	42.3	202.0	V	53.0	57.7	15.4	11.7	54
17945.625000	51.2	201.0	H	40.0	76.0	24.8	2.8	54

Remark: 1. Correction Factor = Antenna factor+ Insertion loss (cable loss + amplifier gain)

RE 18-26.5GHz PK+AV

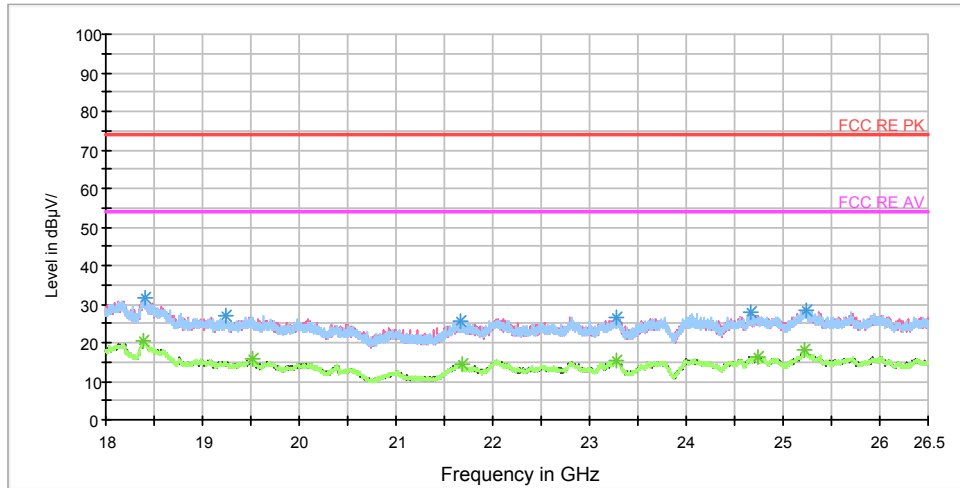

Radiates Emission from 18GHz to 26.5GHz

Frequency (MHz)	Peak (dBuV/m)	Polarization	Azimuth (deg)	Reading value (dBuV/m)	Correct Factor (dB)	Margin (dB)	Limit (dBuV/m)
18399.500000	31.7	V	328.0	36.6	-4.9	42.3	74
19239.937500	27.2	V	297.0	34.0	-6.8	46.8	74
21664.562500	25.5	H	78.0	34.8	-9.3	48.5	74
23284.875000	26.4	H	78.0	33.5	-7.1	47.6	74
24660.812500	27.7	H	0.0	34.7	-7.0	46.3	74
25234.562500	28.6	H	25.0	34.6	-6.0	45.4	74

Remark: 1. Correction Factor = Antenna factor+ Insertion loss (cable loss + amplifier gain)

Frequency (MHz)	Average (dBuV/m)	Polarization	Azimuth (deg)	Reading value (dBuV/m)	Correct Factor (dB)	Margin (dB)	Limit (dBuV/m)
18391.000000	20.7	V	189.0	25.6	-4.9	33.3	54
19513.000000	15.6	H	124.0	23.1	-7.5	38.4	54
21682.625000	14.3	H	0.0	23.7	-9.4	39.7	54
23273.187500	15.5	V	259.0	22.7	-7.2	38.5	54
24733.062500	16.2	H	0.0	22.5	-6.3	37.8	54
25230.312500	18.0	V	245.0	23.9	-5.9	36.0	54

Remark: 1. Correction Factor = Antenna factor+ Insertion loss (cable loss + amplifier gain)

802.11b CH6

FCC RE 0.03-1GHz QP Class B

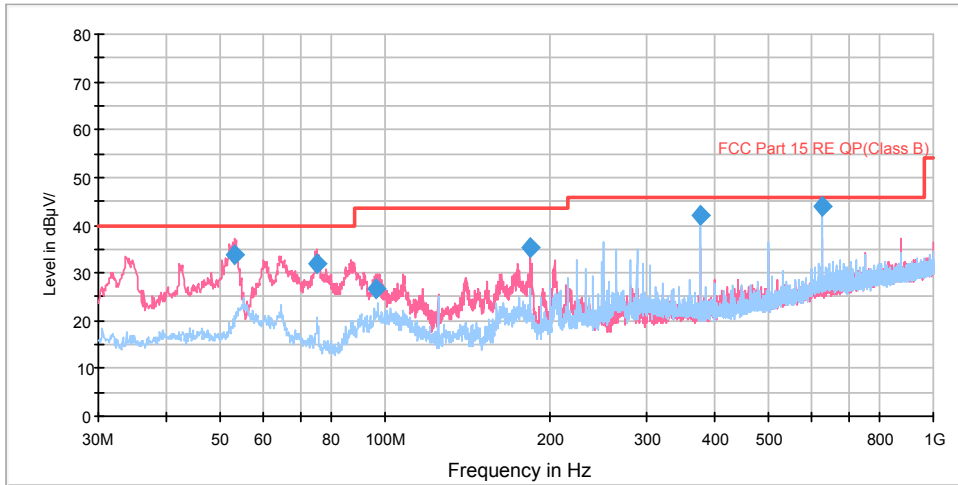

Radiates Emission from 30MHz to 1GHz

Frequency (MHz)	Quasi-Peak (dBuV/m)	Height (cm)	Polarization	Azimuth (deg)	Reading value (dBuV/m)	Correct Factor (dB)	Margin (dB)	Limit (dBuV/m)
53.120000	33.7	100.0	V	93.0	46.5	12.8	6.3	40.0
75.386250	31.9	125.0	V	178.0	40.5	8.6	8.1	40.0
96.612500	26.6	100.0	V	305.0	39.4	12.8	16.9	43.5
184.230000	35.4	100.0	V	17.0	46.5	11.1	8.1	43.5
374.996250	42.1	100.0	H	151.0	59.5	17.4	3.9	46.0
625.015000	44.0	114.0	H	14.0	66.2	22.2	2.0	46.0

Remark: 1. Quasi-Peak = Reading value + Correction factor

2. Correction Factor = Antenna factor+ Insertion loss(cable loss+amplifier gain)

3. Margin = Limit – Quasi-Peak

RE 1G-3GHz PK+AV

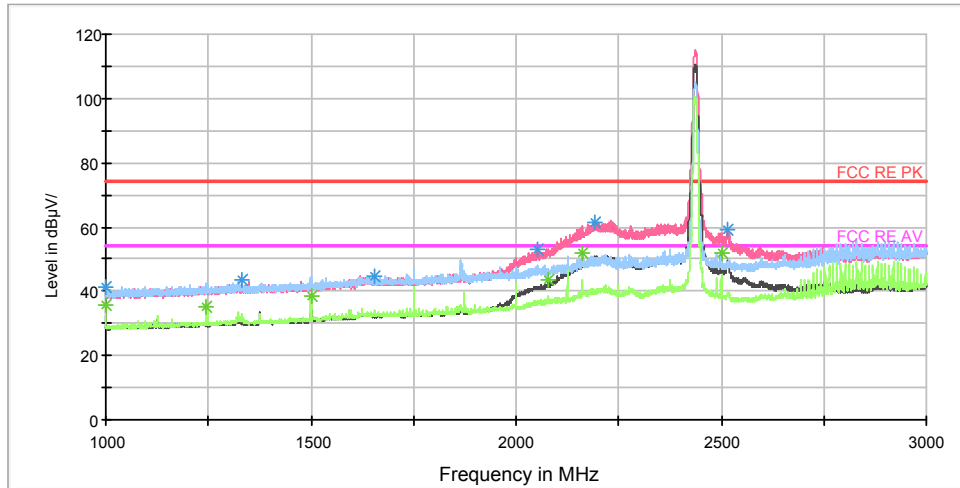

Note: The signal beyond the limit is carrier.

Radiates Emission from 1GHz to 3GHz

Frequency (MHz)	Peak (dBuV/m)	Height (cm)	Polarization	Azimuth (deg)	Reading value (dBuV/m)	Correct Factor (dB)	Margin (dB)	Limit (dBuV/m)
1000.000000	41.6	301.0	H	160.0	50.8	-9.2	32.4	74
1244.000000	41.8	301.0	H	142.0	49.8	-8.0	32.2	74
1500.000000	44.6	199.0	H	238.0	51.3	-6.7	29.4	74
2080.000000	52.4	301.0	V	359.0	55.4	-3.0	21.6	74
2160.000000	60.5	201.0	V	43.0	62.7	-2.2	13.5	74
2500.000000	57.9	201.0	V	155.0	58.1	-0.2	16.1	74

Remark: 1. Correction Factor = Antenna factor+ Insertion loss (cable loss + amplifier gain)

Frequency (MHz)	Average (dBuV/m)	Height (cm)	Polarization	Azimuth (deg)	Reading value (dBuV/m)	Correct Factor (dB)	Margin (dB)	Limit (dBuV/m)
1000.000000	35.5	301.0	H	160.0	44.7	-9.2	18.5	54
1244.000000	35.2	301.0	H	142.0	43.2	-8.0	18.8	54
1500.000000	38.6	199.0	H	238.0	45.3	-6.7	15.4	54
2080.000000	43.8	301.0	V	359.0	46.8	-3.0	10.2	54
2160.000000	52.0	201.0	V	43.0	54.2	-2.2	2.0	54
2500.000000	51.7	201.0	V	155.0	51.9	-0.2	2.3	54

Remark: 1. Correction Factor = Antenna factor+ Insertion loss (cable loss + amplifier gain)

RE 3-18GHz PK+AV

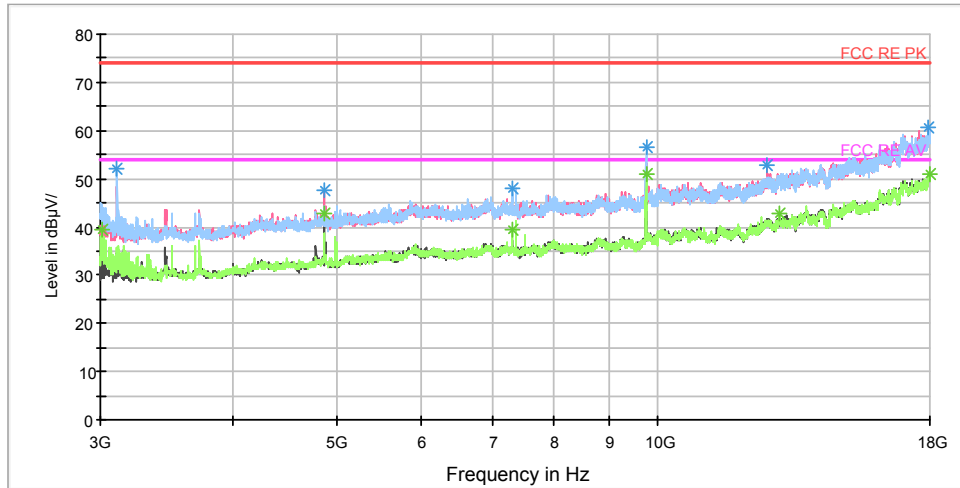

Radiates Emission from 3GHz to 18GHz

Frequency (MHz)	Peak (dBuV/m)	Height (cm)	Polarization	Azimuth (deg)	Reading value (dBuV/m)	Correct Factor (dB)	Margin (dB)	Limit (dBuV/m)
3016.875000	44.1	203.0	H	256.0	46.0	-1.9	29.9	74
4873.125000	47.7	202.0	V	150.0	50.7	3.0	26.3	74
7310.625000	45.0	203.0	H	116.0	53.6	8.6	29.0	74
9748.125000	56.6	203.0	H	177.0	68.2	11.6	17.4	74
13010.625000	49.0	303.0	V	234.0	65.2	16.2	25.0	74
17970.000000	58.9	303.0	V	140.0	84.0	25.1	15.1	74

Remark: 1. Correction Factor = Antenna factor+ Insertion loss (cable loss + amplifier gain)

Frequency (MHz)	Average (dBuV/m)	Height (cm)	Polarization	Azimuth (deg)	Reading value (dBuV/m)	Correct Factor (dB)	Margin (dB)	Limit (dBuV/m)
3016.875000	39.5	203.0	H	256.0	41.4	-1.9	14.5	54
4873.125000	42.7	202.0	V	150.0	45.7	3.0	11.3	54
7310.625000	39.5	203.0	H	116.0	48.1	8.6	14.5	54
9748.125000	50.9	203.0	H	177.0	62.5	11.6	3.1	54
13010.625000	42.8	303.0	V	234.0	59.0	16.2	11.2	54
17970.000000	51.1	303.0	V	140.0	76.2	25.1	2.9	54

Remark: 1. Correction Factor = Antenna factor+ Insertion loss (cable loss + amplifier gain)



RE 18-26.5GHz PK+AV

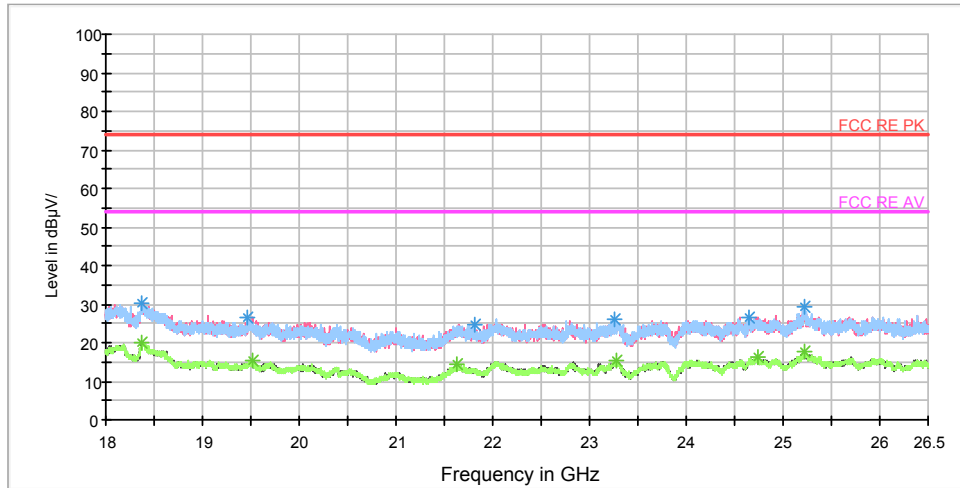

Radiates Emission from 18GHz to 26.5GHz

Frequency (MHz)	Peak (dBuV/m)	Polarization	Azimuth (deg)	Reading value (dBuV/m)	Correct Factor (dB)	Margin (dB)	Limit (dBuV/m)
18377.187500	30.4	V	14.0	35.2	-4.8	43.6	74
19457.750000	26.4	H	0.0	34.6	-8.2	47.6	74
21816.500000	24.7	H	0.0	33.4	-8.7	49.3	74
23259.375000	25.9	H	6.0	33.3	-7.4	48.1	74
24650.187500	26.6	H	15.0	33.6	-7.0	47.4	74
25230.312500	29.1	H	0.0	35.0	-5.9	44.9	74

Remark: 1. Correction Factor = Antenna factor+ Insertion loss (cable loss + amplifier gain)

Frequency (MHz)	Average (dBuV/m)	Polarization	Azimuth (deg)	Reading value (dBuV/m)	Correct Factor (dB)	Margin (dB)	Limit (dBuV/m)
18379.312500	20.1	V	20.0	24.9	-4.8	33.9	54
19518.312500	15.3	H	6.0	22.7	-7.4	38.7	54
21635.875000	14.3	V	14.0	23.4	-9.1	39.7	54
23285.937500	15.2	H	15.0	22.3	-7.1	38.8	54
24738.375000	16.3	H	0.0	22.7	-6.4	37.7	54
25216.500000	17.9	H	0.0	24.0	-6.1	36.1	54

Remark: 1. Correction Factor = Antenna factor+ Insertion loss (cable loss + amplifier gain)

802.11b CH11

FCC RE 0.03-1GHz QP Class B

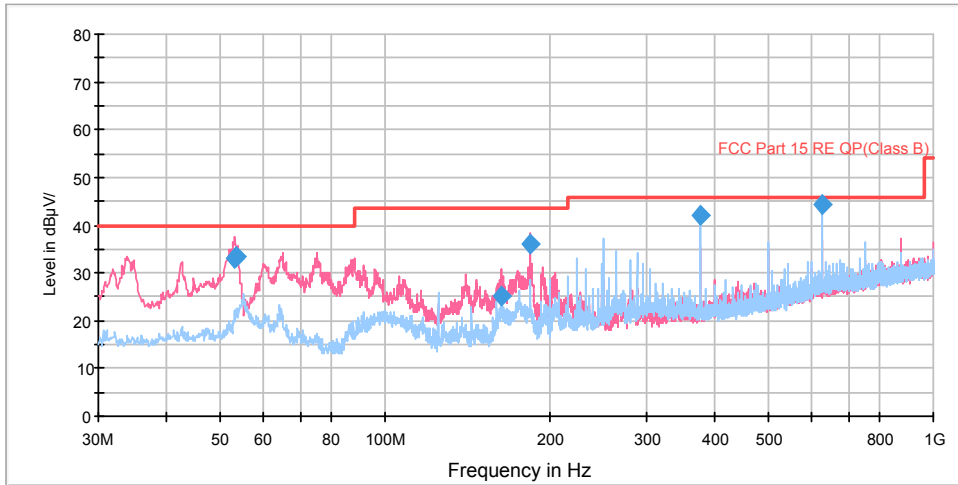

Radiates Emission from 30MHz to 1GHz

Frequency (MHz)	Quasi-Peak (dBuV/m)	Height (cm)	Polarization	Azimuth (deg)	Reading value (dBuV/m)	Correct Factor (dB)	Margin (dB)	Limit (dBuV/m)
53.238750	33.0	100.0	V	115.0	45.8	12.8	7.0	40.0
53.366250	33.4	100.0	V	155.0	46.2	12.8	6.6	40.0
163.011250	25.2	100.0	V	22.0	35.1	9.9	18.3	43.5
184.270000	36.2	100.0	V	34.0	47.3	11.1	7.3	43.5
374.996250	42.2	100.0	H	145.0	59.6	17.4	3.8	46.0
625.015000	44.3	114.0	H	10.0	66.5	22.2	1.7	46.0

Remark: 1. Quasi-Peak = Reading value + Correction factor

2. Correction Factor = Antenna factor+ Insertion loss(cable loss+amplifier gain)

3. Margin = Limit – Quasi-Peak

RE 1G-3GHz PK+AV

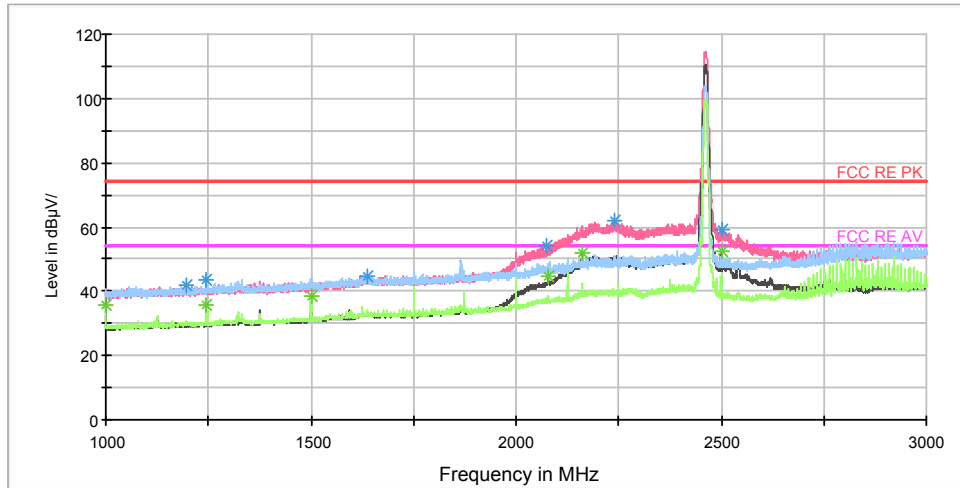

Note: The signal beyond the limit is carrier.

Radiates Emission from 1GHz to 3GHz

Frequency (MHz)	Peak (dBuV/m)	Height (cm)	Polarization	Azimuth (deg)	Reading value (dBuV/m)	Correct Factor (dB)	Margin (dB)	Limit (dBuV/m)
1196.500000	42.1	301.0	H	101.0	50.3	-8.2	31.9	74
1244.500000	43.8	301.0	H	130.0	51.8	-8.0	30.2	74
1639.500000	44.7	301.0	H	65.0	49.4	-4.7	29.3	74
2076.000000	54.0	301.0	V	0.0	57.0	-3.0	20.0	74
2238.750000	61.9	201.0	V	30.0	64.4	-2.5	12.1	74
2500.250000	59.4	201.0	V	103.0	59.6	-0.2	14.6	74

Remark: 1. Correction Factor = Antenna factor+ Insertion loss (cable loss + amplifier gain)

Frequency (MHz)	Average (dBuV/m)	Height (cm)	Polarization	Azimuth (deg)	Reading value (dBuV/m)	Correct Factor (dB)	Margin (dB)	Limit (dBuV/m)
1000.000000	35.5	301.0	H	171.0	44.7	-9.2	18.5	54
1244.250000	35.6	301.0	H	136.0	43.6	-8.0	18.4	54
1500.000000	38.3	202.0	H	280.0	45.0	-6.7	15.7	54
2080.000000	44.8	301.0	V	0.0	47.8	-3.0	9.2	54
2160.000000	51.9	201.0	V	248.0	54.1	-2.2	2.1	54
2500.000000	52.6	201.0	V	109.0	52.8	-0.2	1.4	54

Remark: 1. Correction Factor = Antenna factor+ Insertion loss (cable loss + amplifier gain)

RE 3-18GHz PK+AV

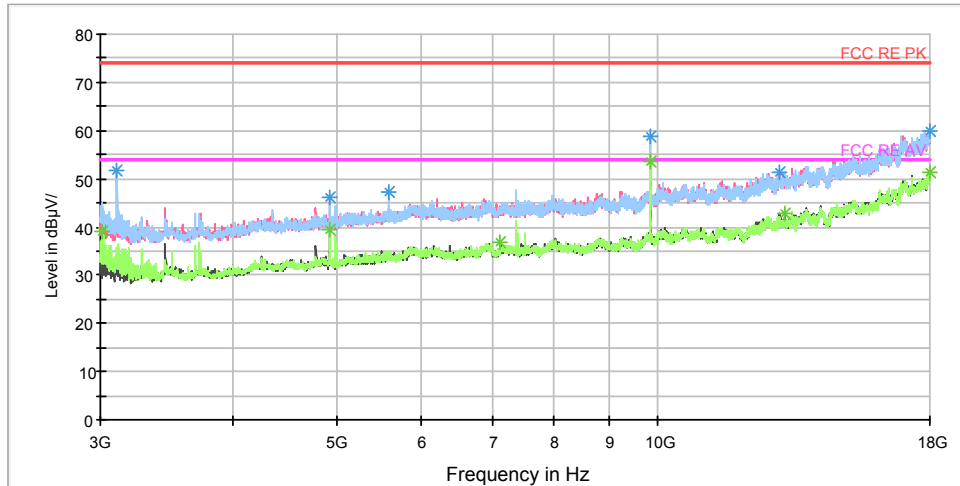

Radiates Emission from 3GHz to 18GHz

Frequency (MHz)	Peak (dBuV/m)	Height (cm)	Polarization	Azimuth (deg)	Reading value (dBuV/m)	Correct Factor (dB)	Margin (dB)	Limit (dBuV/m)
3016.875000	45.2	202.0	H	102.0	47.1	-1.9	28.8	74
4923.750000	46.2	302.0	V	119.0	49.3	3.1	27.8	74
7117.500000	43.1	102.0	H	4.0	51.4	8.3	30.9	74
9847.500000	58.9	202.0	H	173.0	70.7	11.8	15.1	74
13145.625000	49.6	202.0	V	270.0	65.2	15.6	24.4	74
17990.625000	57.7	202.0	V	141.0	83.0	25.3	16.3	74

Remark: 1. Correction Factor = Antenna factor+ Insertion loss (cable loss + amplifier gain)

Frequency (MHz)	Average (dBuV/m)	Height (cm)	Polarization	Azimuth (deg)	Reading value (dBuV/m)	Correct Factor (dB)	Margin (dB)	Limit (dBuV/m)
3016.875000	38.9	202.0	H	102.0	40.8	-1.9	15.1	54
4923.750000	39.6	302.0	V	119.0	42.7	3.1	14.4	54
7117.500000	36.7	102.0	H	4.0	45.0	8.3	17.3	54
9847.500000	53.6	202.0	H	173.0	65.4	11.8	0.4	54
13145.625000	42.7	202.0	V	270.0	58.3	15.6	11.3	54
17990.625000	51.2	202.0	V	141.0	76.5	25.3	2.8	54

Remark: 1. Correction Factor = Antenna factor+ Insertion loss (cable loss + amplifier gain)

RE 18-26.5GHz PK+AV

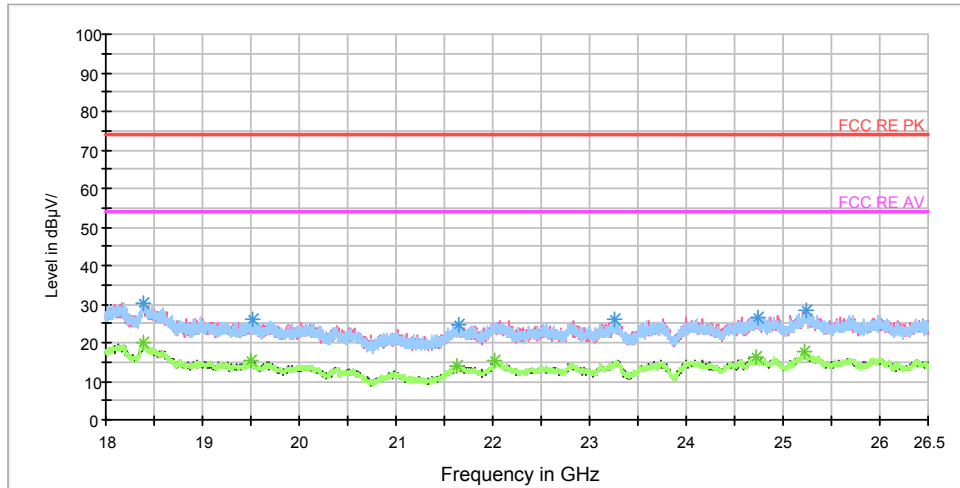

Radiates Emission from 18GHz to 26.5GHz

Frequency (MHz)	Peak (dBuV/m)	Polarization	Azimuth (deg)	Reading value (dBuV/m)	Correct Factor (dB)	Margin (dB)	Limit (dBuV/m)
18394.187500	30.3	V	5.0	35.2	-4.9	43.7	74
19523.625000	25.9	H	0.0	33.3	-7.4	48.1	74
21650.750000	24.8	V	15.0	34.0	-9.2	49.2	74
23256.187500	26.1	H	0.0	33.5	-7.4	47.9	74
24733.062500	26.5	V	15.0	32.8	-6.3	47.5	74
25232.437500	28.2	V	20.0	34.1	-5.9	45.8	74

Remark: 1. Correction Factor = Antenna factor+ Insertion loss (cable loss + amplifier gain)

Frequency (MHz)	Average (dBuV/m)	Polarization	Azimuth (deg)	Reading value (dBuV/m)	Correct Factor (dB)	Margin (dB)	Limit (dBuV/m)
18388.875000	20.1	H	6.0	25.0	-4.9	33.9	54
19502.375000	15.6	V	15.0	23.1	-7.5	38.4	54
21634.812500	14.1	H	0.0	23.2	-9.1	39.9	54
22023.687500	15.3	H	0.0	23.3	-8.0	38.7	54
24725.625000	16.3	V	20.0	22.5	-6.2	37.7	54
25228.187500	17.7	V	0.0	23.6	-5.9	36.3	54

Remark: 1. Correction Factor = Antenna factor+ Insertion loss (cable loss + amplifier gain)

802.11g CH1

FCC RE 0.03-1GHz QP Class B

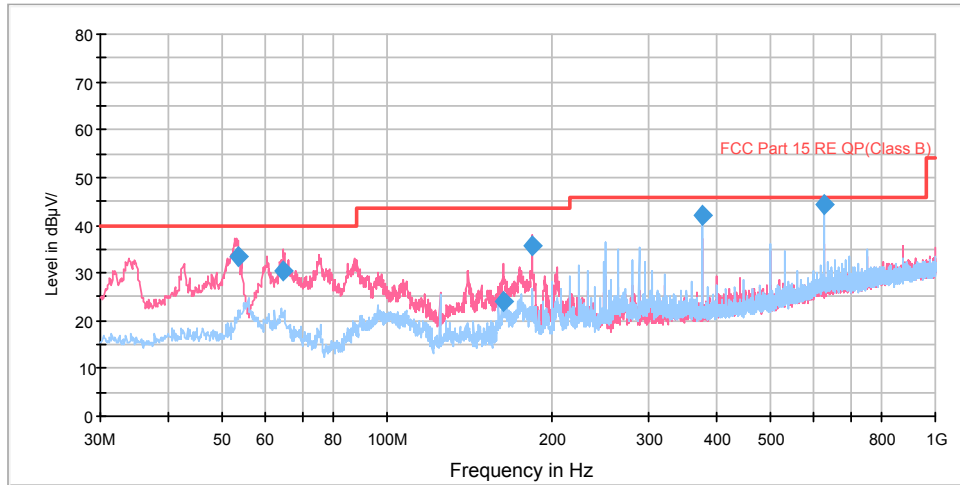

Radiates Emission from 30MHz to 1GHz

Frequency (MHz)	Quasi-Peak (dBuV/m)	Height (cm)	Polarization	Azimuth (deg)	Reading value (dBuV/m)	Correct Factor (dB)	Margin (dB)	Limit (dBuV/m)
53.358750	33.6	100.0	V	111.0	46.4	12.8	6.4	40.0
64.517500	30.4	100.0	V	26.0	41.1	10.7	9.6	40.0
163.332500	24.1	100.0	V	0.0	34.0	9.9	19.4	43.5
184.270000	35.6	100.0	V	17.0	46.7	11.1	7.9	43.5
374.996250	42.2	100.0	H	146.0	59.6	17.4	3.8	46.0
625.015000	44.3	114.0	H	10.0	66.5	22.2	1.7	46.0

Remark: 1. Quasi-Peak = Reading value + Correction factor

2. Correction Factor = Antenna factor+ Insertion loss(cable loss+amplifier gain)

3. Margin = Limit – Quasi-Peak

RE 1G-3GHz PK+AV

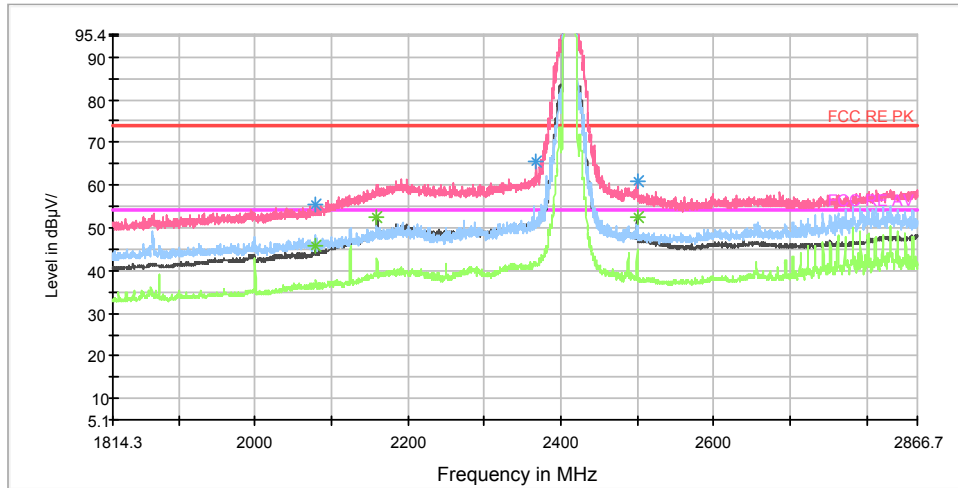

Note: The signal beyond the limit is carrier.

Radiates Emission from 1GHz to 3GHz

Frequency (MHz)	Peak (dBuV/m)	Height (cm)	Polarization	Azimuth (deg)	Reading value (dBuV/m)	Correct Factor (dB)	Margin (dB)	Limit (dBuV/m)
1179.000000	48.9	202.0	V	50.0	56.9	-8.0	25.1	74
1398.000000	49.1	202.0	V	124.0	56.2	-7.1	24.9	74
1639.750000	52.8	202.0	V	56.0	57.5	-4.7	21.2	74
2079.500000	55.6	202.0	V	62.0	58.6	-3.0	18.4	74
2368.500000	65.5	202.0	V	38.0	67.0	-1.5	8.5	74
2500.000000	61.0	202.0	V	8.0	61.2	-0.2	13.0	74

Remark: 1. Correction Factor = Antenna factor+ Insertion loss (cable loss + amplifier gain)

Frequency (MHz)	Average (dBuV/m)	Height (cm)	Polarization	Azimuth (deg)	Reading value (dBuV/m)	Correct Factor (dB)	Margin (dB)	Limit (dBuV/m)
1125.000000	37.4	202.0	V	44.0	45.8	-8.4	16.6	54
1434.500000	38.3	202.0	V	105.0	45.2	-6.9	15.7	54
1627.250000	41.2	202.0	V	56.0	46.0	-4.8	12.8	54
2080.000000	45.7	202.0	V	32.0	48.7	-3.0	8.3	54
2160.000000	52.4	202.0	V	69.0	54.6	-2.2	1.6	54
2500.000000	52.5	202.0	V	8.0	52.7	-0.2	1.5	54

Remark: 1. Correction Factor = Antenna factor+ Insertion loss (cable loss + amplifier gain)

RE 3-18GHz PK+AV

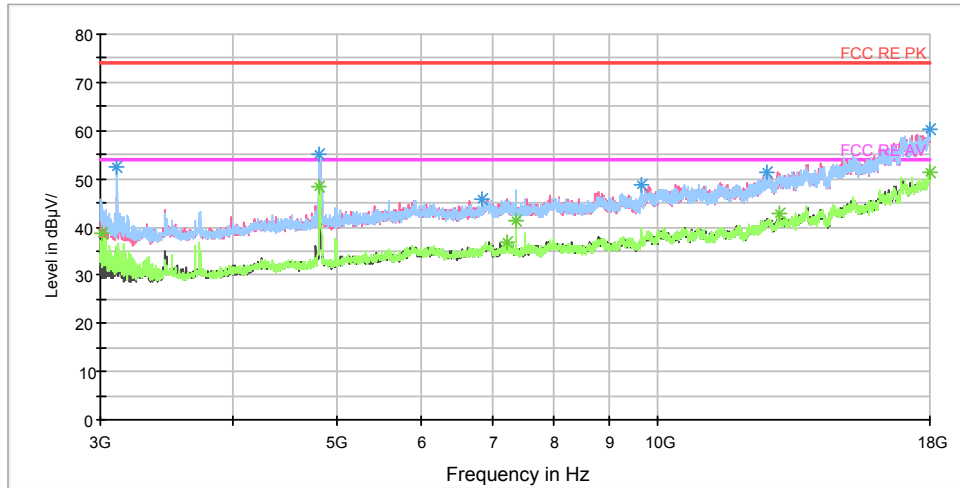

Radiates Emission from 3GHz to 18GHz

Frequency (MHz)	Peak (dBuV/m)	Height (cm)	Polarization	Azimuth (deg)	Reading value (dBuV/m)	Correct Factor (dB)	Margin (dB)	Limit (dBuV/m)
3016.875000	44.0	202.0	H	115.0	45.9	-1.9	30.0	74
4818.750000	55.1	202.0	H	237.0	57.8	2.7	18.9	74
7231.875000	43.5	202.0	V	35.0	52.2	8.7	30.5	74
7372.500000	47.8	202.0	H	237.0	55.9	8.1	26.2	74
13006.875000	49.8	302.0	H	57.0	66.0	16.2	24.2	74
17985.000000	57.6	101.0	H	256.0	82.8	25.2	16.4	74

Remark: 1. Correction Factor = Antenna factor+ Insertion loss (cable loss + amplifier gain)

Frequency (MHz)	Average (dBuV/m)	Height (cm)	Polarization	Azimuth (deg)	Reading value (dBuV/m)	Correct Factor (dB)	Margin (dB)	Limit (dBuV/m)
3016.875000	38.8	202.0	H	115.0	40.7	-1.9	15.2	54
4818.750000	48.2	202.0	H	237.0	50.9	2.7	5.8	54
7231.875000	36.8	202.0	V	35.0	45.5	8.7	17.2	54
7372.500000	41.2	202.0	H	237.0	49.3	8.1	12.8	54
13006.875000	43.0	302.0	H	57.0	59.2	16.2	11.0	54
17985.000000	51.3	101.0	H	256.0	76.5	25.2	2.7	54

Remark: 1. Correction Factor = Antenna factor+ Insertion loss (cable loss + amplifier gain)



RE 18-26.5GHz PK+AV

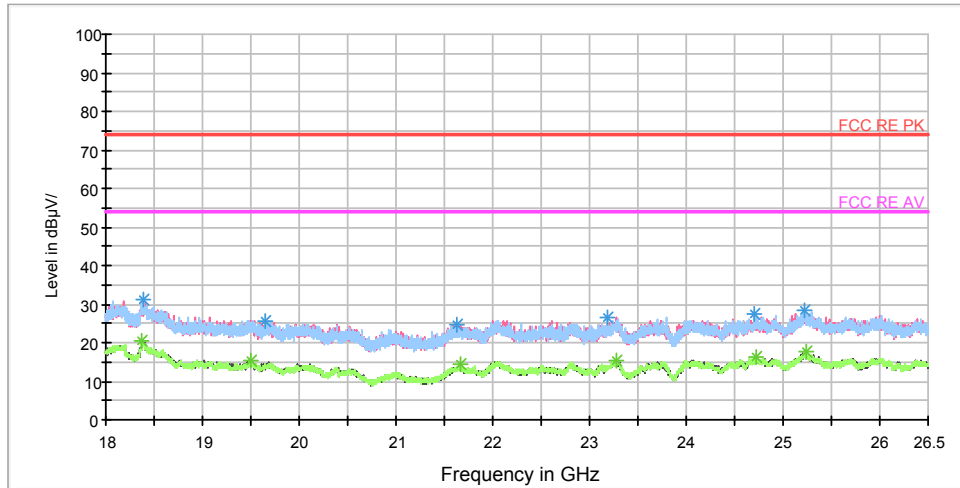

Radiates Emission from 18GHz to 26.5GHz

Frequency (MHz)	Peak (dBuV/m)	Polarization	Azimuth (deg)	Reading value (dBuV/m)	Correct Factor (dB)	Margin (dB)	Limit (dBuV/m)
18380.375000	31.3	V	20.0	36.1	-4.8	42.7	74
19642.625000	25.7	H	0.0	33.3	-7.6	48.3	74
21635.875000	24.9	H	5.0	34.0	-9.1	49.1	74
23178.625000	26.3	H	0.0	34.8	-8.5	47.7	74
24698.000000	27.7	H	0.0	34.5	-6.8	46.3	74
25218.625000	28.5	H	5.0	34.5	-6.0	45.5	74

Remark: 1. Correction Factor = Antenna factor+ Insertion loss (cable loss + amplifier gain)

Frequency (MHz)	Average (dBuV/m)	Polarization	Azimuth (deg)	Reading value (dBuV/m)	Correct Factor (dB)	Margin (dB)	Limit (dBuV/m)
18376.125000	20.4	H	0.0	25.1	-4.7	33.6	54
19503.437500	15.5	H	0.0	23.0	-7.5	38.5	54
21658.187500	14.2	V	0.0	23.4	-9.2	39.8	54
23281.687500	15.2	H	0.0	22.3	-7.1	38.8	54
24721.375000	16.1	H	0.0	22.4	-6.3	37.9	54
25232.437500	17.8	V	20.0	23.7	-5.9	36.2	54

Remark: 1. Correction Factor = Antenna factor+ Insertion loss (cable loss + amplifier gain)

802.11g CH6

FCC RE 0.03-1GHz QP Class B

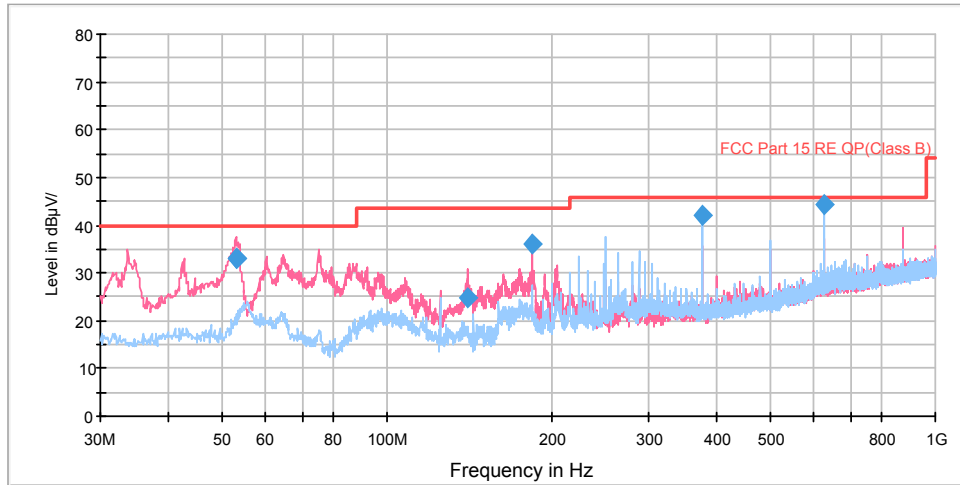

Radiates Emission from 30MHz to 1GHz

Frequency (MHz)	Quasi-Peak (dBuV/m)	Height (cm)	Polarization	Azimuth (deg)	Reading value (dBuV/m)	Correct Factor (dB)	Margin (dB)	Limit (dBuV/m)
53.117500	33.2	100.0	V	109.0	46.0	12.8	6.8	40.0
53.286250	33.1	100.0	V	153.0	45.9	12.8	6.9	40.0
140.295000	24.9	100.0	V	0.0	33.8	8.9	18.6	43.5
184.270000	36.0	100.0	V	338.0	47.1	11.1	7.5	43.5
374.996250	42.2	100.0	H	146.0	59.6	17.4	3.8	46.0
625.015000	44.3	114.0	H	10.0	66.5	22.2	1.7	46.0

Remark: 1. Quasi-Peak = Reading value + Correction factor

2. Correction Factor = Antenna factor+ Insertion loss(cable loss+amplifier gain)

3. Margin = Limit – Quasi-Peak



RE 1G-3GHz PK+AV

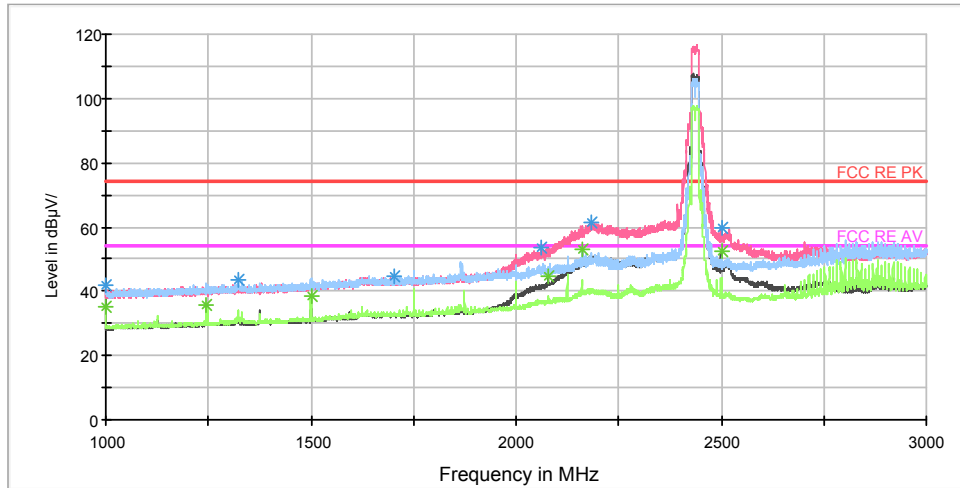

Note: The signal beyond the limit is carrier.

Radiates Emission from 1GHz to 3GHz

Frequency (MHz)	Peak (dBuV/m)	Height (cm)	Polarization	Azimuth (deg)	Reading value (dBuV/m)	Correct Factor (dB)	Margin (dB)	Limit (dBuV/m)
1000.000000	41.8	301.0	H	153.0	51.0	-9.2	32.2	74
1323.500000	43.5	202.0	H	167.0	50.8	-7.3	30.5	74
1701.750000	44.7	301.0	V	230.0	49.6	-4.9	29.3	74
2059.250000	53.4	301.0	V	0.0	56.5	-3.1	20.6	74
2185.000000	61.5	201.0	V	0.0	63.7	-2.2	12.5	74
2500.250000	59.7	201.0	V	323.0	59.9	-0.2	14.3	74

Remark: 1. Correction Factor = Antenna factor+ Insertion loss (cable loss + amplifier gain)

Frequency (MHz)	Average (dBuV/m)	Height (cm)	Polarization	Azimuth (deg)	Reading value (dBuV/m)	Correct Factor (dB)	Margin (dB)	Limit (dBuV/m)
1000.000000	35.3	301.0	H	153.0	44.5	-9.2	18.7	54
1244.000000	35.5	301.0	H	129.0	43.5	-8.0	18.5	54
1500.000000	38.6	202.0	H	257.0	45.3	-6.7	15.4	54
2080.000000	44.9	201.0	V	62.0	47.9	-3.0	9.1	54
2160.000000	53.0	201.0	V	38.0	55.2	-2.2	1.0	54
2500.250000	52.6	201.0	V	323.0	52.8	-0.2	1.4	54

Remark: 1. Correction Factor = Antenna factor+ Insertion loss (cable loss + amplifier gain)

RE 3-18GHz PK+AV

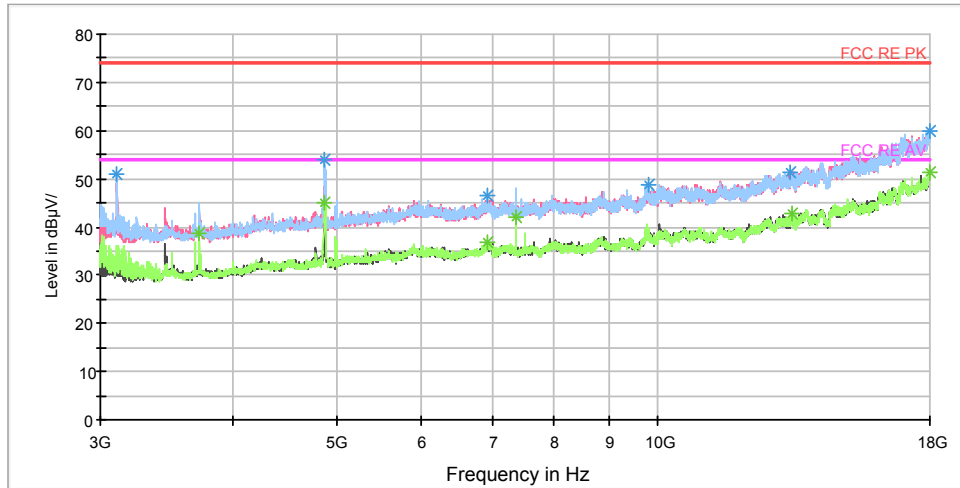

Radiates Emission from 3GHz to 18GHz

Frequency (MHz)	Peak (dBuV/m)	Height (cm)	Polarization	Azimuth (deg)	Reading value (dBuV/m)	Correct Factor (dB)	Margin (dB)	Limit (dBuV/m)
3718.125000	45.1	202.0	H	244.0	45.4	-0.3	28.9	74
4873.125000	51.3	202.0	H	165.0	54.3	3.0	22.7	74
6918.750000	44.0	202.0	V	90.0	50.9	6.9	30.0	74
7372.500000	48.0	202.0	H	221.0	56.1	8.1	26.0	74
13350.000000	49.9	303.0	H	244.0	65.7	15.8	24.1	74
17986.875000	58.3	102.0	H	320.0	83.5	25.2	15.7	74

Remark: 1. Correction Factor = Antenna factor+ Insertion loss (cable loss + amplifier gain)

Frequency (MHz)	Average (dBuV/m)	Height (cm)	Polarization	Azimuth (deg)	Reading value (dBuV/m)	Correct Factor (dB)	Margin (dB)	Limit (dBuV/m)
3718.125000	38.6	202.0	H	244.0	38.9	-0.3	15.4	54
4873.125000	45.1	202.0	H	165.0	48.1	3.0	8.9	54
6918.750000	36.9	202.0	V	90.0	43.8	6.9	17.1	54
7372.500000	41.9	202.0	H	221.0	50.0	8.1	12.1	54
13350.000000	42.7	303.0	H	244.0	58.5	15.8	11.3	54
17986.875000	51.4	102.0	H	320.0	76.6	25.2	2.6	54

Remark: 1. Correction Factor = Antenna factor+ Insertion loss (cable loss + amplifier gain)

RE 18-26.5GHz PK+AV

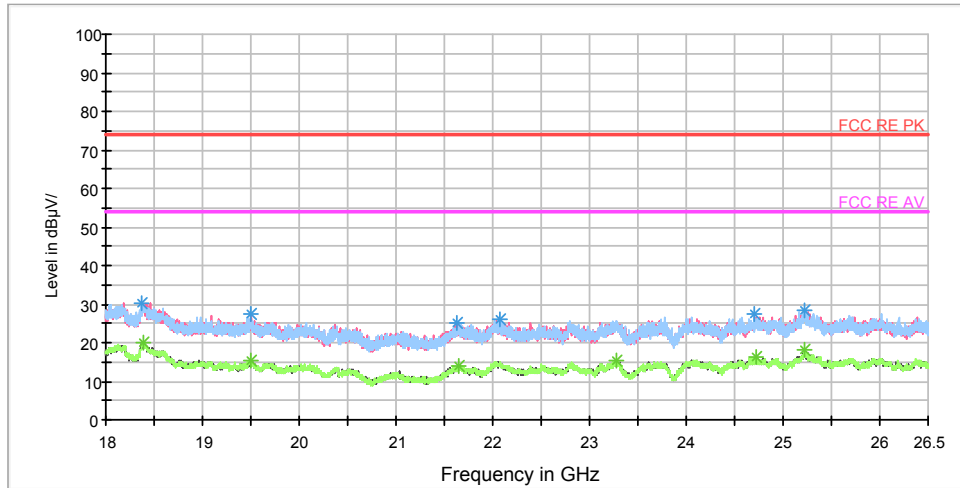

Radiates Emission from 18GHz to 26.5GHz

Frequency (MHz)	Peak (dBuV/m)	Polarization	Azimuth (deg)	Reading value (dBuV/m)	Correct Factor (dB)	Margin (dB)	Limit (dBuV/m)
18371.875000	30.4	V	20.0	35.2	-4.8	43.6	74
19508.750000	27.2	V	20.0	34.7	-7.5	46.8	74
21635.875000	25.0	V	16.0	34.1	-9.1	49.0	74
22069.375000	26.1	H	0.0	34.2	-8.1	47.9	74
24699.062500	27.2	H	20.0	34.0	-6.8	46.8	74
25222.875000	28.6	V	20.0	34.5	-5.9	45.4	74

Remark: 1. Correction Factor = Antenna factor+ Insertion loss (cable loss + amplifier gain)

Frequency (MHz)	Average (dBuV/m)	Polarization	Azimuth (deg)	Reading value (dBuV/m)	Correct Factor (dB)	Margin (dB)	Limit (dBuV/m)
18393.125000	20.1	H	0.0	25.0	-4.9	33.9	54
19496.000000	15.2	H	0.0	22.8	-7.6	38.8	54
21651.812500	14.1	H	0.0	23.3	-9.2	39.9	54
23281.687500	15.4	V	20.0	22.5	-7.1	38.6	54
24729.875000	16.3	V	16.0	22.5	-6.2	37.7	54
25231.375000	17.9	V	16.0	23.8	-5.9	36.1	54

Remark: 1. Correction Factor = Antenna factor+ Insertion loss (cable loss + amplifier gain)

802.11g CH11

FCC RE 0.03-1GHz QP Class B

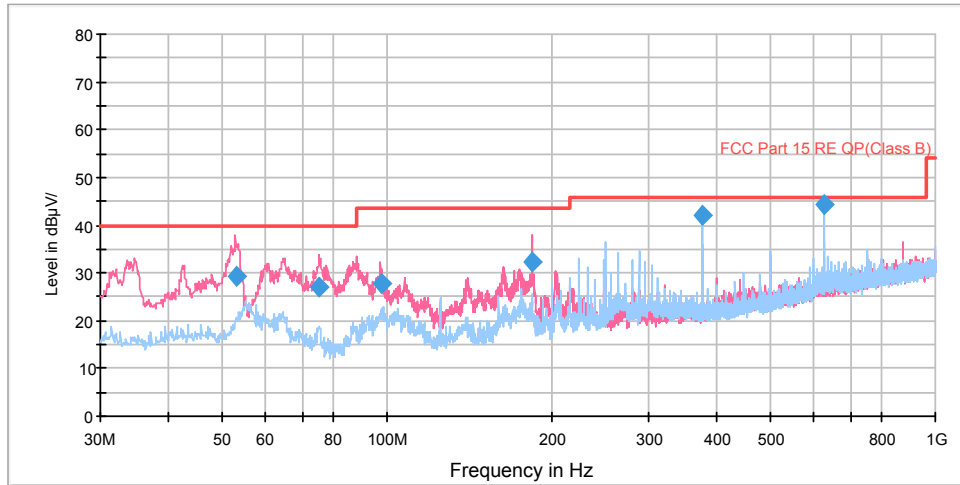

Radiates Emission from 30MHz to 1GHz

Frequency (MHz)	Quasi-Peak (dBuV/m)	Height (cm)	Polarization	Azimuth (deg)	Reading value (dBuV/m)	Correct Factor (dB)	Margin (dB)	Limit (dBuV/m)
53.116250	29.2	111.0	V	221.0	42.0	12.8	10.8	40.0
75.186250	26.9	125.0	V	173.0	35.5	8.6	13.1	40.0
97.413750	27.9	100.0	V	34.0	40.8	12.9	15.6	43.5
184.270000	32.4	100.0	V	22.0	43.5	11.1	11.1	43.5
374.996250	42.1	100.0	H	146.0	59.5	17.4	3.9	46.0
625.015000	44.3	114.0	H	10.0	66.5	22.2	1.7	46.0

Remark: 1. Quasi-Peak = Reading value + Correction factor

2. Correction Factor = Antenna factor+ Insertion loss(cable loss+amplifier gain)

3. Margin = Limit – Quasi-Peak

RE 1G-3GHz PK+AV

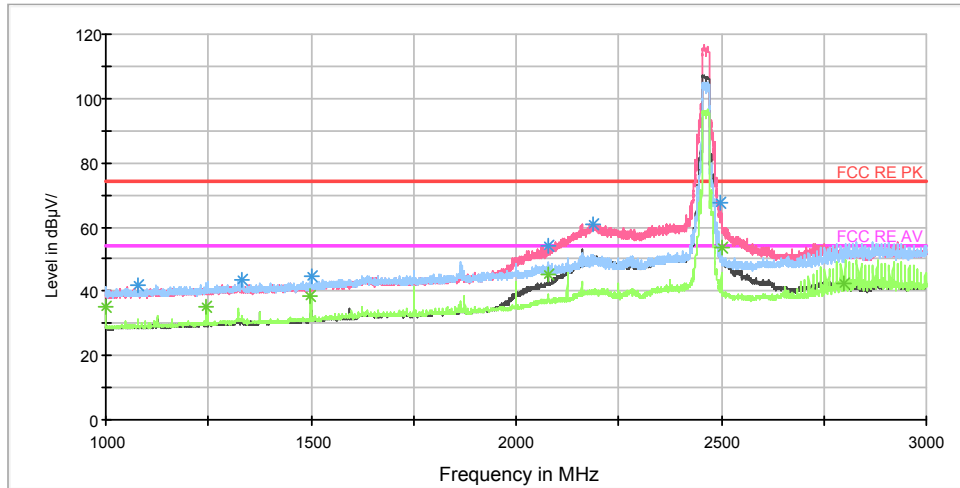

Note: The signal beyond the limit is carrier.

Radiates Emission from 1GHz to 3GHz

Frequency (MHz)	Peak (dBuV/m)	Height (cm)	Polarization	Azimuth (deg)	Reading value (dBuV/m)	Correct Factor (dB)	Margin (dB)	Limit (dBuV/m)
1079.500000	41.8	301.0	V	0.0	50.7	-8.9	32.2	74
1332.750000	43.5	301.0	H	143.0	50.9	-7.4	30.5	74
1500.250000	44.7	202.0	H	227.0	51.4	-6.7	29.3	74
2079.750000	54.1	301.0	V	353.0	57.1	-3.0	19.9	74
2186.250000	61.0	202.0	V	0.0	63.2	-2.2	13.0	74
2499.000000	67.4	202.0	V	155.0	67.5	-0.1	6.6	74

Remark: 1. Correction Factor = Antenna factor+ Insertion loss (cable loss + amplifier gain)

Frequency (MHz)	Average (dBuV/m)	Height (cm)	Polarization	Azimuth (deg)	Reading value (dBuV/m)	Correct Factor (dB)	Margin (dB)	Limit (dBuV/m)
1000.000000	35.1	301.0	H	180.0	44.3	-9.2	18.9	54
1244.250000	35.2	301.0	H	131.0	43.2	-8.0	18.8	54
1499.750000	38.7	202.0	H	253.0	45.4	-6.7	15.3	54
2080.000000	45.1	301.0	V	0.0	48.1	-3.0	8.9	54
2500.000000	53.7	202.0	V	328.0	53.9	-0.2	0.3	54
2801.000000	42.6	202.0	H	180.0	43.7	1.1	11.4	54

Remark: 1. Correction Factor = Antenna factor+ Insertion loss (cable loss + amplifier gain)



RE 3-18GHz PK+AV

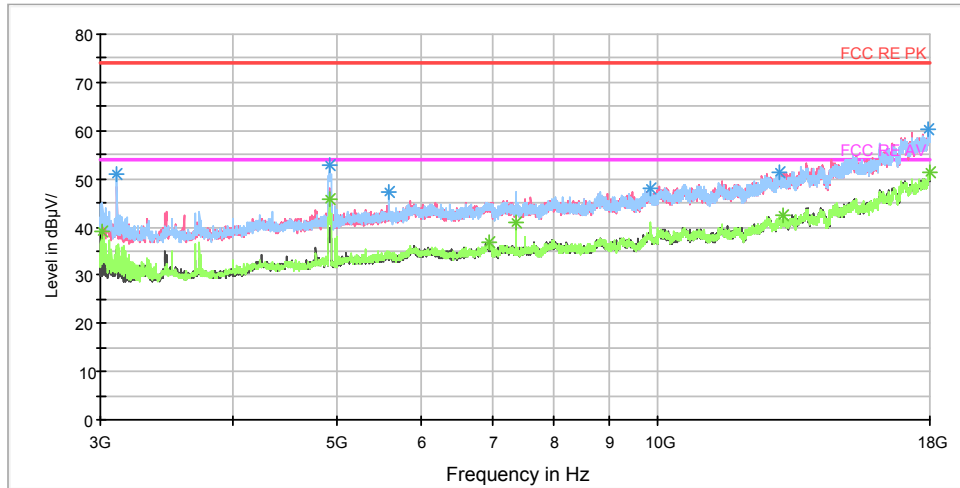

Radiates Emission from 3GHz to 18GHz

Frequency (MHz)	Peak (dBuV/m)	Height (cm)	Polarization	Azimuth (deg)	Reading value (dBuV/m)	Correct Factor (dB)	Margin (dB)	Limit (dBuV/m)
3016.875000	44.6	202.0	H	152.0	46.5	-1.9	29.4	74
4925.625000	52.3	202.0	H	235.0	55.4	3.1	21.7	74
6941.250000	43.7	202.0	V	20.0	50.4	6.7	30.3	74
7372.500000	47.3	202.0	H	235.0	55.4	8.1	26.7	74
13121.250000	49.1	302.0	H	0.0	65.0	15.9	24.9	74
17998.125000	57.7	202.0	V	306.0	83.1	25.4	16.3	74

Remark: 1. Correction Factor = Antenna factor+ Insertion loss (cable loss + amplifier gain)

Frequency (MHz)	Average (dBuV/m)	Height (cm)	Polarization	Azimuth (deg)	Reading value (dBuV/m)	Correct Factor (dB)	Margin (dB)	Limit (dBuV/m)
3016.875000	39.1	202.0	H	152.0	41.0	-1.9	14.9	54
4925.625000	45.8	202.0	H	235.0	48.9	3.1	8.2	54
6941.250000	36.9	202.0	V	20.0	43.6	6.7	17.1	54
7372.500000	41.1	202.0	H	235.0	49.2	8.1	12.9	54
13121.250000	42.3	302.0	H	0.0	58.2	15.9	11.7	54
17998.125000	51.2	202.0	V	306.0	76.6	25.4	2.8	54

Remark: 1. Correction Factor = Antenna factor+ Insertion loss (cable loss + amplifier gain)



RE 18-26.5GHz PK+AV

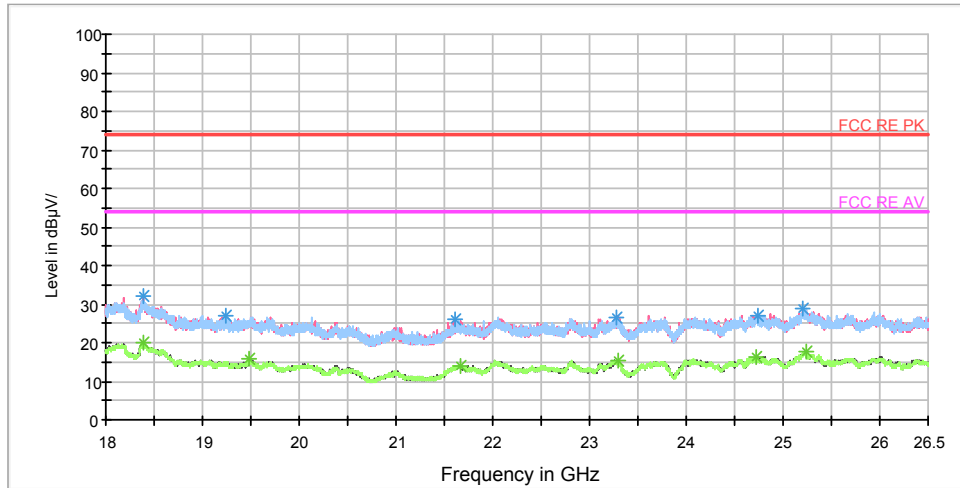

Radiates Emission from 18GHz to 26.5GHz

Frequency (MHz)	Peak (dBuV/m)	Polarization	Azimuth (deg)	Reading value (dBuV/m)	Correct Factor (dB)	Margin (dB)	Limit (dBuV/m)
18391.000000	32.2	V	100.0	37.1	-4.9	41.8	74
19239.937500	26.8	V	300.0	33.6	-6.8	47.2	74
21617.812500	25.8	V	272.0	34.8	-9.0	48.2	74
23282.750000	26.7	H	0.0	33.8	-7.1	47.3	74
24740.500000	27.2	V	240.0	33.7	-6.5	46.8	74
25208.000000	28.8	V	52.0	35.1	-6.3	45.2	74

Remark: 1. Correction Factor = Antenna factor+ Insertion loss (cable loss + amplifier gain)

Frequency (MHz)	Average (dBuV/m)	Polarization	Azimuth (deg)	Reading value (dBuV/m)	Correct Factor (dB)	Margin (dB)	Limit (dBuV/m)
18383.562500	20.2	V	76.0	25.0	-4.8	33.8	54
19489.625000	16.0	V	155.0	23.6	-7.6	38.0	54
21672.000000	14.2	V	138.0	23.5	-9.3	39.8	54
23288.062500	15.4	H	0.0	22.5	-7.1	38.6	54
24730.937500	16.3	H	0.0	22.5	-6.2	37.7	54
25233.500000	17.8	H	203.0	23.7	-5.9	36.2	54

Remark: 1. Correction Factor = Antenna factor+ Insertion loss (cable loss + amplifier gain)



802.11n (HT20) CH1

RE 30M-1GHz QP

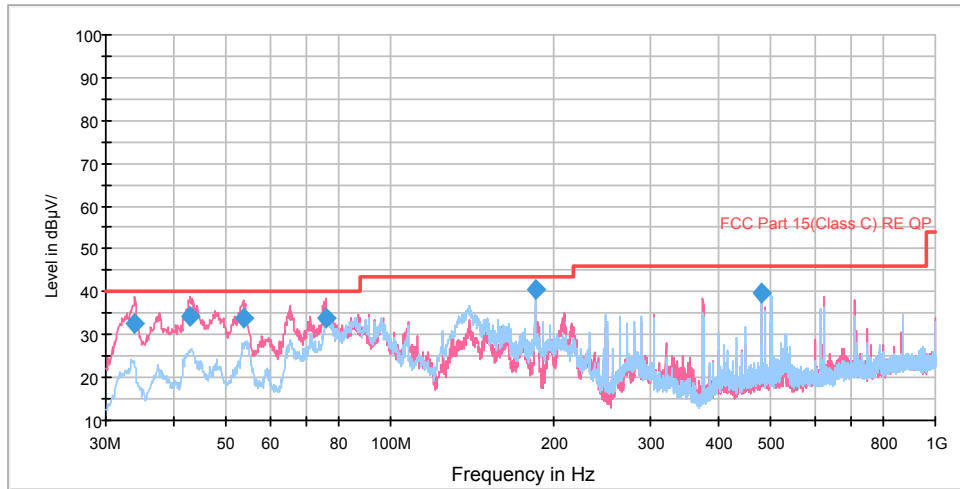

Radiates Emission from 30MHz to 1GHz

Frequency (MHz)	Quasi-Peak (dBuV/m)	Height (cm)	Polarization	Azimuth (deg)	Reading value (dBuV/m)	Correct Factor (dB)	Margin (dB)	Limit (dBuV/m)
33.795300	32.7	100.0	V	142.0	55.3	-22.6	7.3	40.0
42.959631	34.3	102.0	V	189.0	54.9	-20.6	5.7	40.0
53.777860	33.7	101.0	V	224.0	54.5	-20.8	6.3	40.0
75.884812	34.1	176.0	V	108.0	62.8	-28.7	5.9	40.0
184.249425	40.7	126.0	H	120.0	68.3	-27.6	2.8	43.5
479.233250	39.5	99.0	V	179.0	58.9	-19.4	6.5	46.0

- Remark: 1. Quasi-Peak = Reading value + Correction factor  
 2. Correction Factor = Antenna factor+ Insertion loss(cable loss+amplifier gain)  
 3. Margin = Limit – Quasi-Peak



RE 1G-3GHz PK+AV

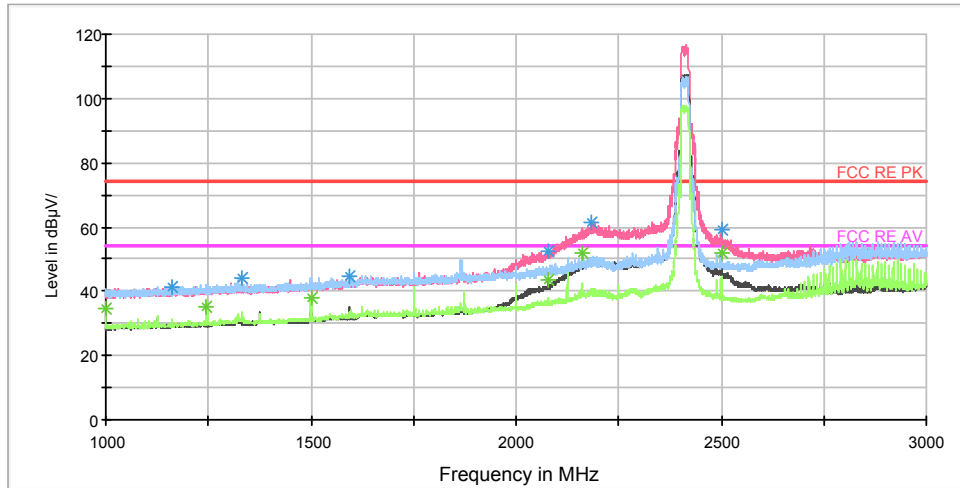

Note: The signal beyond the limit is carrier.

Radiates Emission from 1GHz to 3GHz

Frequency (MHz)	Peak (dBuV/m)	Height (cm)	Polarization	Azimuth (deg)	Reading value (dBuV/m)	Correct Factor (dB)	Margin (dB)	Limit (dBuV/m)
1159.750000	41.5	301.0	H	129.0	49.9	-8.4	32.5	74
1333.500000	44.2	301.0	H	153.0	51.6	-7.4	29.8	74
1593.750000	44.7	301.0	V	356.0	51.1	-6.4	29.3	74
2079.750000	52.4	301.0	V	0.0	55.4	-3.0	21.6	74
2185.500000	61.4	201.0	V	289.0	63.6	-2.2	12.6	74
2500.250000	59.4	201.0	V	331.0	59.6	-0.2	14.6	74

Remark: 1. Correction Factor = Antenna factor+ Insertion loss (cable loss + amplifier gain)

Frequency (MHz)	Average (dBuV/m)	Height (cm)	Polarization	Azimuth (deg)	Reading value (dBuV/m)	Correct Factor (dB)	Margin (dB)	Limit (dBuV/m)
1000.000000	34.6	301.0	H	153.0	43.8	-9.2	19.4	54
1244.000000	35.3	301.0	H	116.0	43.3	-8.0	18.7	54
1500.000000	38.0	202.0	H	254.0	44.7	-6.7	16.0	54
2080.000000	43.5	201.0	V	58.0	46.5	-3.0	10.5	54
2160.250000	51.7	201.0	V	102.0	53.9	-2.2	2.3	54
2500.250000	51.8	201.0	V	331.0	52.0	-0.2	2.2	54

Remark: 1. Correction Factor = Antenna factor+ Insertion loss (cable loss + amplifier gain)

RE 3-18GHz PK+AV

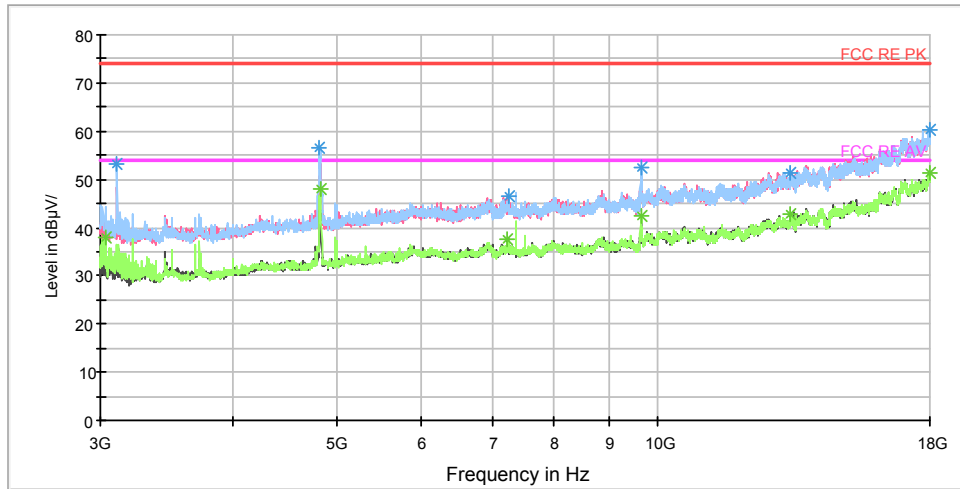

Radiates Emission from 3GHz to 18GHz

Frequency (MHz)	Peak (dBuV/m)	Height (cm)	Polarization	Azimuth (deg)	Reading value (dBuV/m)	Correct Factor (dB)	Margin (dB)	Limit (dBuV/m)
3035.625000	44.2	203.0	H	127.0	46.0	-1.8	29.8	74
4824.375000	55.4	203.0	H	234.0	58.2	2.8	18.6	74
7228.125000	45.4	202.0	V	69.0	54.1	8.7	28.6	74
9654.375000	48.4	203.0	H	139.0	58.9	10.5	25.6	74
13321.875000	49.3	202.0	V	138.0	64.9	15.6	24.7	74
17996.250000	58.8	302.0	H	307.0	84.2	25.4	15.2	74

Remark: 1. Correction Factor = Antenna factor+ Insertion loss (cable loss + amplifier gain)

Frequency (MHz)	Average (dBuV/m)	Height (cm)	Polarization	Azimuth (deg)	Reading value (dBuV/m)	Correct Factor (dB)	Margin (dB)	Limit (dBuV/m)
3035.625000	37.8	203.0	H	127.0	39.6	-1.8	16.2	54
4824.375000	48.1	203.0	H	234.0	50.9	2.8	5.9	54
7228.125000	37.7	202.0	V	69.0	46.4	8.7	16.3	54
9654.375000	42.4	203.0	H	139.0	52.9	10.5	11.6	54
13321.875000	42.6	202.0	V	138.0	58.2	15.6	11.4	54
17996.250000	51.4	302.0	H	307.0	76.8	25.4	2.6	54

Remark: 1. Correction Factor = Antenna factor+ Insertion loss (cable loss + amplifier gain)

RE 18-26.5GHz PK+AV

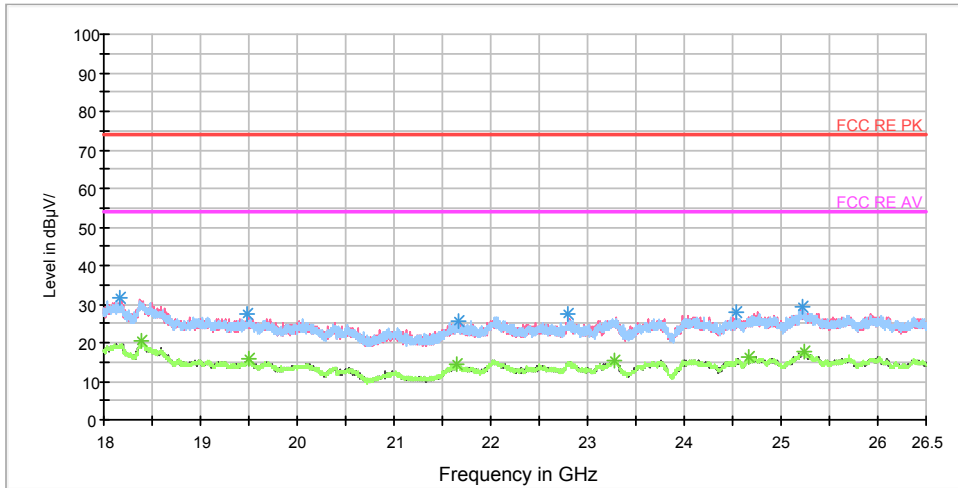

Radiates Emission from 18GHz to 26.5GHz

Frequency (MHz)	Peak (dBuV/m)	Polarization	Azimuth (deg)	Reading value (dBuV/m)	Correct Factor (dB)	Margin (dB)	Limit (dBuV/m)
18171.062500	31.8	H	276.0	36.9	-5.1	42.2	74
19484.312500	27.4	H	147.0	35.1	-7.7	46.6	74
21660.312500	25.7	V	32.0	34.9	-9.2	48.3	74
22802.500000	27.2	H	0.0	34.6	-7.4	46.8	74
24534.375000	27.7	H	28.0	35.8	-8.1	46.3	74
25226.062500	29.2	V	81.0	35.1	-5.9	44.8	74

Remark: 1. Correction Factor = Antenna factor+ Insertion loss (cable loss + amplifier gain)

Frequency (MHz)	Average (dBuV/m)	Polarization	Azimuth (deg)	Reading value (dBuV/m)	Correct Factor (dB)	Margin (dB)	Limit (dBuV/m)
18389.937500	20.5	V	229.0	25.4	-4.9	33.5	54
19505.562500	15.6	V	207.0	23.1	-7.5	38.4	54
21656.062500	14.4	V	276.0	23.6	-9.2	39.6	54
23278.500000	15.4	V	229.0	22.6	-7.2	38.6	54
24658.687500	16.5	H	79.0	23.5	-7.0	37.5	54
25235.625000	17.8	H	86.0	23.8	-6.0	36.2	54

Remark: 1. Correction Factor = Antenna factor+ Insertion loss (cable loss + amplifier gain)

802.11n (HT20) CH6

FCC RE 0.03-1GHz QP Class B

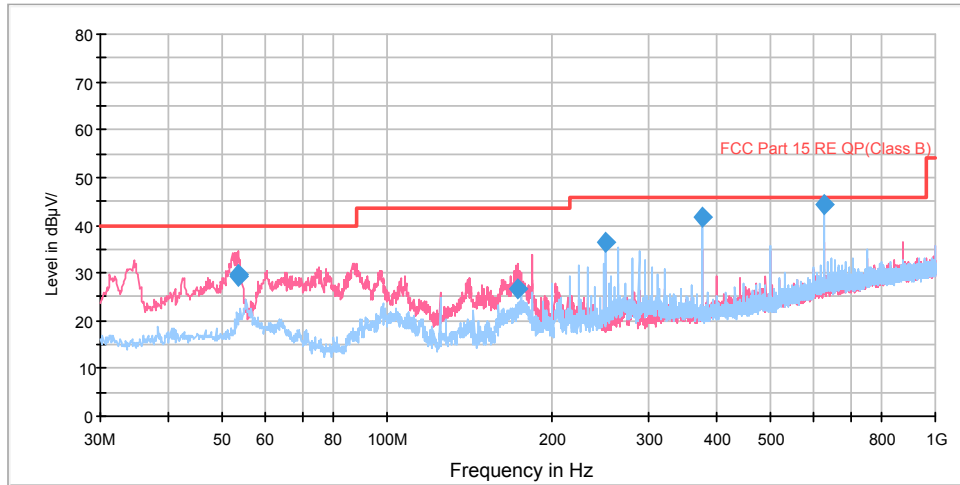

Radiates Emission from 30MHz to 1GHz

Frequency (MHz)	Quasi-Peak (dBuV/m)	Height (cm)	Polarization	Azimuth (deg)	Reading value (dBuV/m)	Correct Factor (dB)	Margin (dB)	Limit (dBuV/m)
53.362500	29.2	100.0	V	107.0	42.0	12.8	10.8	40.0
53.407500	29.8	100.0	V	187.0	42.6	12.8	10.2	40.0
173.068750	26.5	100.0	V	356.0	37.0	10.5	17.0	43.5
249.987500	36.4	100.0	H	0.0	50.5	14.1	9.6	46.0
374.996250	41.9	100.0	H	156.0	59.3	17.4	4.1	46.0
625.015000	44.3	114.0	H	10.0	66.5	22.2	1.7	46.0

- Remark: 1. Quasi-Peak = Reading value + Correction factor  
 2. Correction Factor = Antenna factor+ Insertion loss(cable loss+amplifier gain)  
 3. Margin = Limit – Quasi-Peak