



EMC TEST REPORT

Applicant Alcatel-Lucent Shanghai Bell Co., Ltd.
FCC ID 2ADZRG240WZA
Brand NOKIA
Product Digital Home ONU
Model G-240WZ-A
Report No. YBA1604-0033EMC02R1
Issue Date June 7, 2016

TA Technology (Shanghai) Co., Ltd. tested the above equipment in accordance with the requirements in **FCC Code CFR47 Part15B (2015)/ ANSI C63.4 (2014)**. The test results show that the equipment tested is capable of demonstrating compliance with the requirements as documented in this report.

Wei Liu

Reviewed by: Wei Liu

Guangchang Fan

Approved by: Guangchang Fan



中国认可
国际互认
检测
TESTING
CNAS L2264

TA Technology (Shanghai) Co., Ltd.

No.145, Jintang Rd, Tangzhen Industry Park, Pudong Shanghai, China

TEL: +86-021-50791141/2/3

FAX: +86-021-50791141/2/3-8000

Table of Contents

1	Test Laboratory.....	4
1.1	Notes of the Test Report.....	4
1.2	Test facility.....	4
1.3	Testing Location.....	5
2	General Description of Equipment under Test.....	6
2.1	Client Information.....	6
2.2	General information.....	6
2.3	Applied Standards.....	8
3	Test Case Results.....	9
3.1	Radiated Emission.....	9
3.2	Conducted Emission.....	16
4	Main Test Equipment.....	19
ANNEX A:	The EUT Appearance and Test Configuration.....	20
A.1	EUT Appearance.....	20
A.2	Test Setup.....	22

Summary of measurement results

Number	Test Case	Clause in FCC Rules	Conclusion
1	Radiated Emission	15.109, ANSI C63.4-2014	PASS
2	Conducted Emission	15.107, ANSI C63.4-2014	PASS
Test Date: May 7, 2016 to May 10, 2016			

1 Test Laboratory

1.1 Notes of the Test Report

This report shall not be reproduced in full or partial, without the written approval of TA technology (shanghai) co., Ltd).The results documented in this report apply only to the tested sample, under the conditions and modes of operation as described herein .Measurement Uncertainties were not taken into account and are published for informational purposes only. This report is written to support regulatory compliance of the applicable standards stated above. This report must not be used by the client to claim product certification, approval, or endorsement by CNAS or any government agencies.

1.2 Test facility

CNAS (accreditation number: L2264)

TA Technology (Shanghai) Co., Ltd. has obtained the accreditation of China National Accreditation Service for Conformity Assessment (CNAS).

FCC (recognition number is 428261)

TA Technology (Shanghai) Co., Ltd. has been listed on the US Federal Communications Commission list of test facilities recognized to perform electromagnetic emissions measurements.

IC (recognition number is 8510A)

TA Technology (Shanghai) Co., Ltd. has been listed by industry Canada to perform electromagnetic emission measurement.

VCCI (recognition number is C-4595, T-2154, R-4113, G-766)

TA Technology (Shanghai) Co., Ltd. has been listed by industry Japan to perform electromagnetic emission measurement.

A2LA (Certificate Number: 3857.01)

TA Technology (Shanghai) Co., Ltd. has been listed by American Association for Laboratory Accreditation to perform electromagnetic emission measurement.

1.3 Testing Location

Company: TA Technology (Shanghai) Co., Ltd.
Address: No.145, Jintang Rd, Tangzhen Industry Park, Pudong Shanghai, China
City: Shanghai
Post code: 201201
Country: P. R. China
Contact: Xu Kai
Telephone: +86-021-50791141/2/3
Fax: +86-021-50791141/2/3-8000
Website: <http://www.ta-shanghai.com>
E-mail: xukai@ta-shanghai.com

2 General Description of Equipment under Test

2.1 Client Information

Applicant	Alcatel-Lucent Shanghai Bell Co.,Ltd.
Applicant address	388-389#,Ningqiao Road,Pudong Jinqiao, Shanghai P.R. China
Manufacturer	Taicang T&W Electronics Co.,Ltd
Manufacturer address	Jiangnan Road 89,Ludu Town, Taicang P.R. China

2.2 General information

EUT Description	
Device Type:	Portable Device
Product Name:	Digital Home ONU
Model Number:	G-240WZ-A
HW Version:	PEM 1+
SW Version:	3FE45890FFEB38
IMEI:	/
Antenna Type:	Internal Antenna
Used Host Product:	PC: Model: DELL E6430(SN : 32RKWW1)
Test Mode:	Transfer Data Mode
EUT Accessory	
Adapter	Manufacture: DONGGUAN SHILONG FUHUA ELECTRONIC CO.,LTD. Model : UES36-120300SPA1
Remark: The information of the EUT is declared by the manufacturer. Please refer to the specifications or user manual for details.	

Configurations

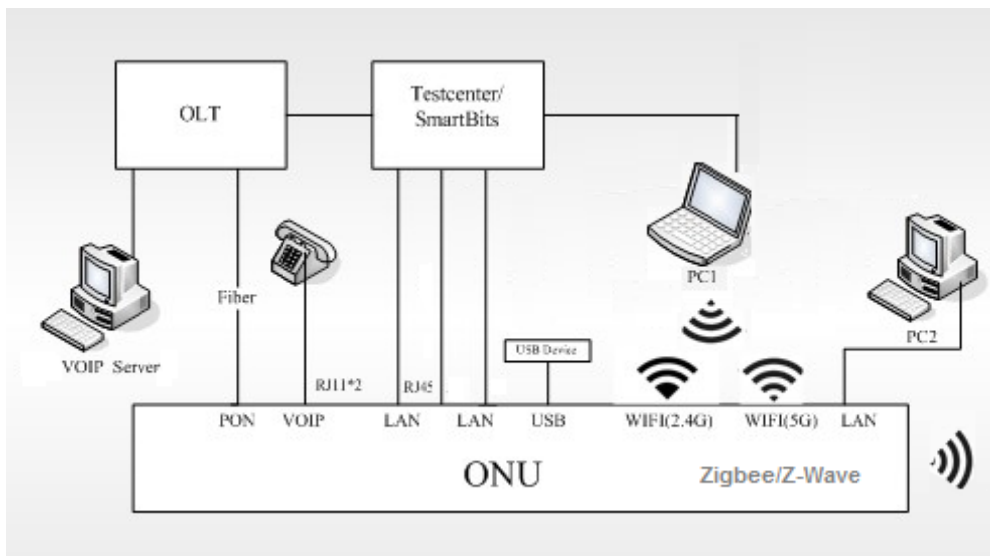

No.	Name	Model/Code No.	Edition	Serial No. or Quantity
1	G-240WZ-A	3FE 45688AABA	PEM1	N.A
3	Power adapter	UES36-120300SPA1	01	N.A

Auxiliary Equipment

No.	Name	Brand name	Model	ASB code	Valid Until
1	SmartBits	Spirent	SMB600B	N.A	N.A
2	OLT	Alcatel-Lucent	7360 ISAM FX-4	N.A	N.A
3	Phone	N.A	N.A	N.A	N.A
4	Computer	N.A	N.A	N.A	N.A

Port description

No.	Port name	Number	Shielded or unshielded	Cable type (optic, twisted pair, etc.)	Max. Cable length
1	AC power	1	N.A	N.A	N.A
2	Gigabit Ethernet	4	Unshielded	Multi twisted pair	N.A
3	POTS	2	unshielded	Twisted pair	N.A
4	PON	1	unshielded	Optic	N.A
5	USB	2	shielded	Twisted pair	N.A



2.3 Applied Standards

According to the specifications of the manufacturer, it must comply with the requirements of the following standards:

Test standards

FCC Code CFR47 Part15B (2015)

ANSI C63.4 (2014)

3 Test Case Results

3.1 Radiated Emission

Ambient condition

Temperature	Relative humidity	Pressure
24°C~26°C	45%~50%	102.5kPa

Methods of Measurement

The EUT is placed on a non-metallic table 0.8m above the horizontal metal reference ground plane. The distance between EUT and receive antenna should be 3 meters. During the test, the EUT was operating in its typical mode. The test method is according to ANSI C63.4-2014. Sweep the whole frequency band through the range from 30MHz to the 5th harmonic of the carrier. During the test, the height of receive antenna shall be moved from 1 to 4 meters, and the antenna shall be performed under horizontal and vertical polarization. The turn table shall be rotated from 0 to 360 degrees for detecting the maximum of radiated signal level.

The data of cable loss and antenna factor has been calibrated in full testing frequency range before the testing. During the test, the EUT is worked at maximum output power.

Set the spectrum analyzer in the following:

Below 1GHz:

RBW=100 kHz / VBW=300 kHz / Sweep=AUTO

Above 1GHz:

(a) PEAK: RBW=1MHz VBW=3MHz/ Sweep=AUTO

(b) AVERAGE: RBW=1MHz / VBW=3MHz / Sweep=AUTO

During the test, EUT is connected to a laptop via a USB cable in the case of Transfer Data mode. The EUT is used as the peripheral equipment of the PC. The data is transferred from EUT to PC; PC is connected to server via a long LAN cable.

Test Setup

Below 1GHz

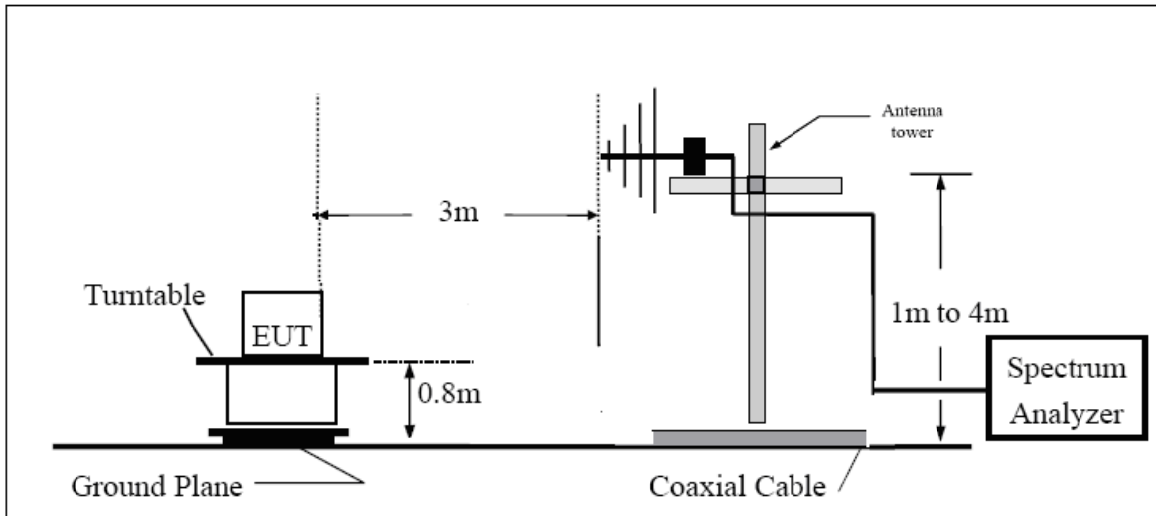

Above 1GHz

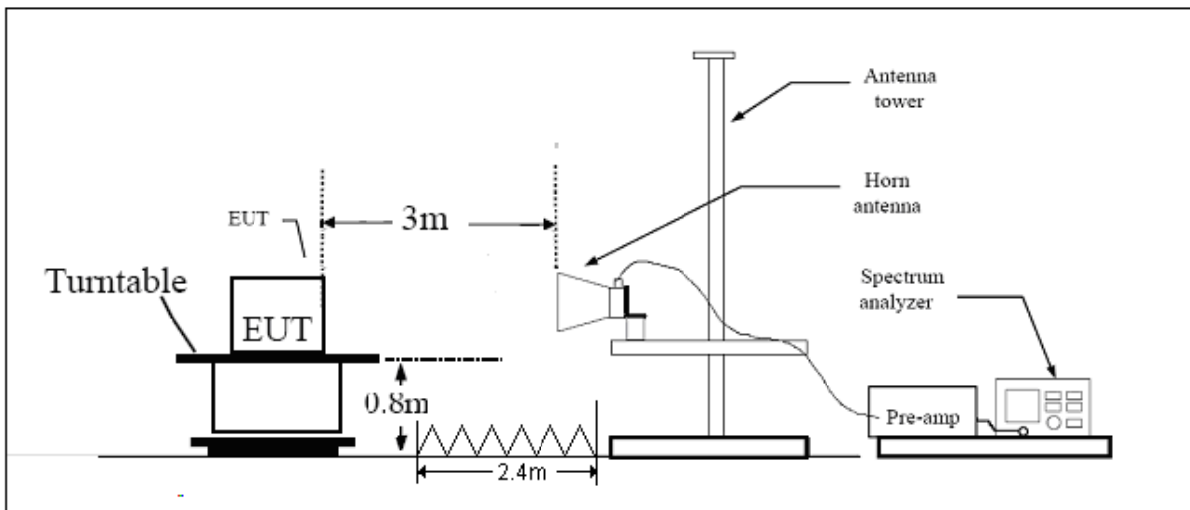

Note: Area side:2.4mX3.6m

Antenna Tower meets ANSI C63.4 requirements for measurements above 1 GHz by keeping the antenna aimed at the EUT during the antenna's ascent/ descent along the antenna mast.

Limits

Frequency (MHz)	Field Strength (dB μ V/m)	Detector
30 -88	40.0	Quasi-peak
88-216	43.5	Quasi-peak
216 – 960	46.0	Quasi-peak
960-1000	54.0	Quasi-peak
1000-5 th harmonic of the highest frequency or 40GHz, which is lower	54 74	Average Peak

Measurement Uncertainty

The assessed measurement uncertainty to ensure 95% confidence level for the normal distribution is with the coverage factor $k = 1.96$. $U = 3.92$ dB.

Test Results

The following graphs display the maximum values of horizontal and vertical by software.
 For above 1GHz, Blue trace uses the peak detection, Green trace uses the average detection.

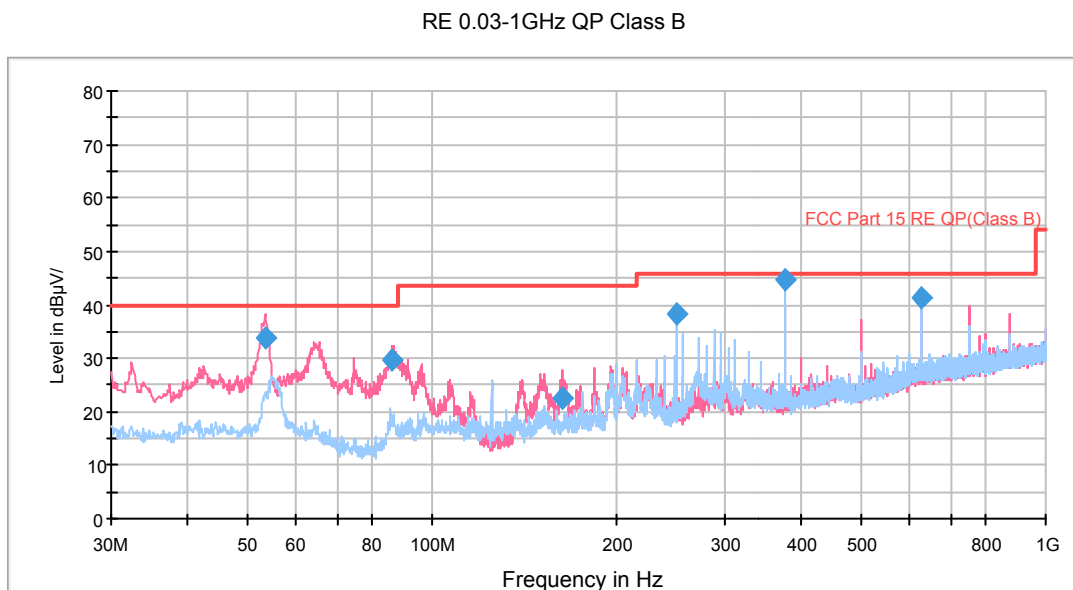

Radiated Emission from 30MHz to 1GHz

Frequency (MHz)	Quasi-Peak (dBuV/m)	Reading value (dBuV/m)	Height (cm)	Polarization	Azimuth (deg)	Correct Factor (dB)	Margin (dB)	Limit (dBuV/m)
53.361250	33.6	46.4	101.0	V	38.0	12.8	6.4	40.0
86.337500	29.9	40.5	126.0	V	191.0	10.6	10.1	40.0
163.328750	22.6	32.5	126.0	V	196.0	9.9	20.9	43.5
249.987500	38.2	52.3	101.0	H	18.0	14.1	7.8	46.0
374.996250	44.7	62.1	101.0	H	34.0	17.4	1.3	46.0
625.015000	41.2	63.4	115.0	H	0.0	22.2	4.8	46.0

- Remark:**
1. Quasi-Peak = Reading value + Correction factor
 2. Correction Factor = Antenna factor+ Insertion loss(cable loss+amplifier gain)
 3. Margin = Limit – Quasi-Peak

RE 1G-3GHz PK+AV

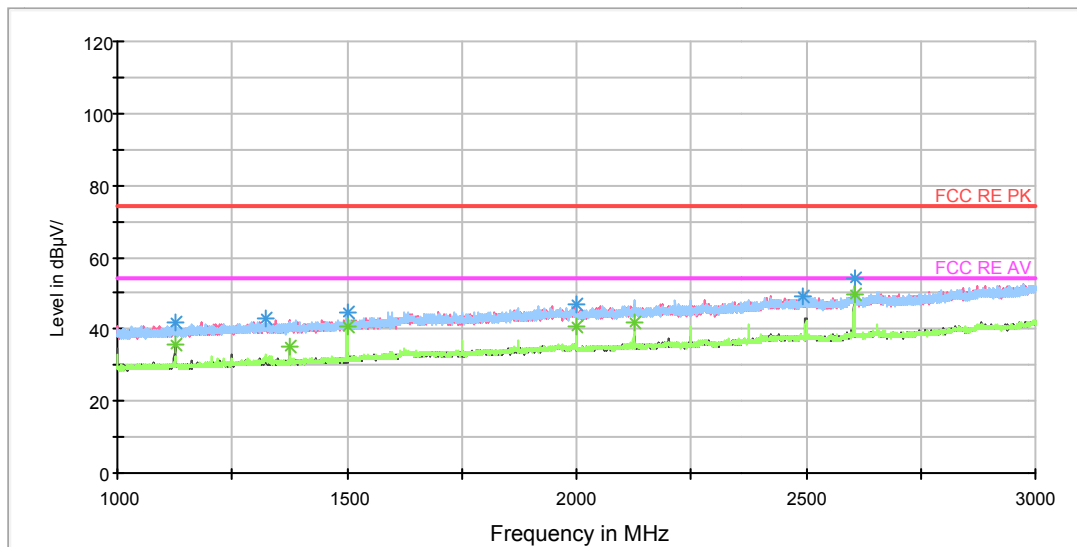

Radiated Emission from 1GHz to 3GHz

Frequency (MHz)	Peak (dBuV/m)	Reading value (dBuV/m)	Height (cm)	Polarization	Azimuth (deg)	Correct Factor (dB)	Margin (dB)	Limit (dBuV/m)
1124.500000	41.9	50.4	100.0	V	0.0	-8.5	32.1	74
1323.500000	42.7	50.0	100.0	H	0.0	-7.3	31.3	74
1500.000000	44.8	51.5	100.0	H	28.0	-6.7	29.2	74
1999.750000	47.1	50.5	100.0	H	91.0	-3.4	26.9	74
2493.000000	49.1	49.3	100.0	H	18.0	0.2	24.9	74
2605.250000	54.0	54.3	100.0	V	0.0	0.3	20.0	74

Frequency (MHz)	Average (dBuV/m)	Reading value (dBuV/m)	Height (cm)	Polarization	Azimuth (deg)	Correct Factor (dB)	Margin (dB)	Limit (dBuV/m)
1125.000000	35.9	44.3	100.0	V	0.0	-8.4	18.1	54
1375.000000	35.2	42.3	100.0	V	0.0	-7.1	18.8	54
1500.000000	40.8	47.5	100.0	H	28.0	-6.7	13.2	54
1999.750000	40.9	44.3	100.0	H	91.0	-3.4	13.1	54
2125.000000	41.9	44.2	100.0	H	255.0	-2.3	12.1	54
2605.500000	49.7	50.0	100.0	V	0.0	0.3	4.3	54

RE 3-18GHz PK+AV_BELL SWEEP

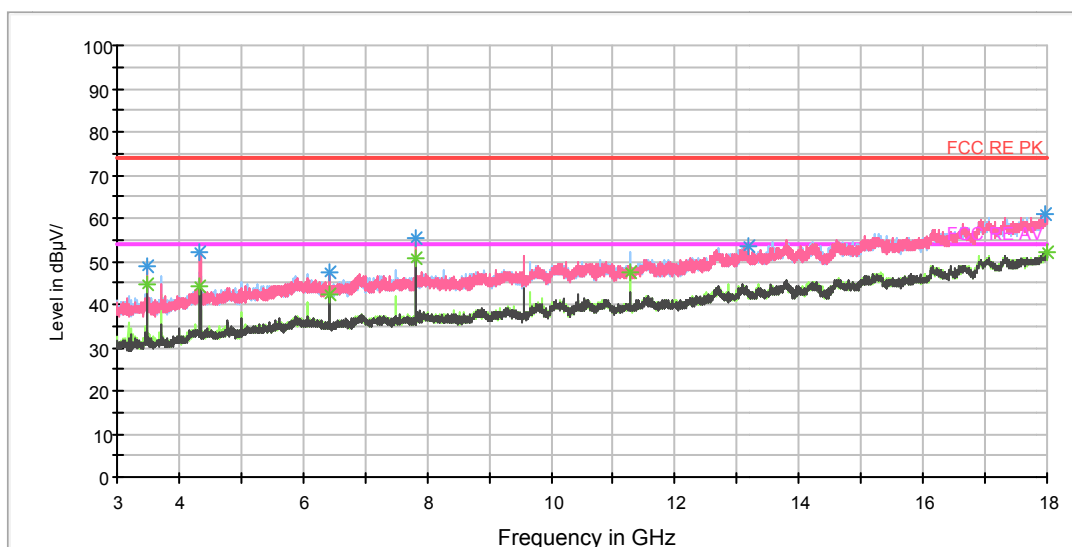

Radiated Emission from 3GHz to 18GHz

Frequency (MHz)	Peak (dBuV/m)	Reading value (dBuV/m)	Height (cm)	Polarization	Azimuth (deg)	Correct Factor (dB)	Margin (dB)	Limit (dBuV/m)
3472.500000	48.9	49.6	100.0	V	156.0	-0.7	25.1	74
4340.625000	52.2	54.3	100.0	V	188.0	2.1	21.8	74
6431.250000	47.3	53.4	100.0	V	11.0	6.1	26.7	74
7815.000000	55.5	64.0	100.0	V	164.0	8.5	18.5	74
13173.750000	53.6	68.9	100.0	V	34.0	15.3	20.4	74
17979.375000	60.8	86.0	100.0	H	275.0	25.2	13.2	74

Frequency (MHz)	Average (dBuV/m)	Reading value (dBuV/m)	Height (cm)	Polarization	Azimuth (deg)	Correct Factor (dB)	Margin (dB)	Limit (dBuV/m)
3472.500000	44.5	45.2	100.0	V	156.0	-0.7	9.5	54
4340.625000	44.4	46.5	100.0	V	188.0	2.1	9.6	54
6431.250000	42.3	48.4	100.0	V	11.0	6.1	11.7	54
7815.000000	50.9	59.4	100.0	V	164.0	8.5	3.1	54
11289.375000	47.3	59.7	100.0	H	228.0	12.4	6.7	54
17998.125000	52.1	77.5	100.0	V	2.0	25.4	1.9	54

RE 18-26.5GHz PK+AV

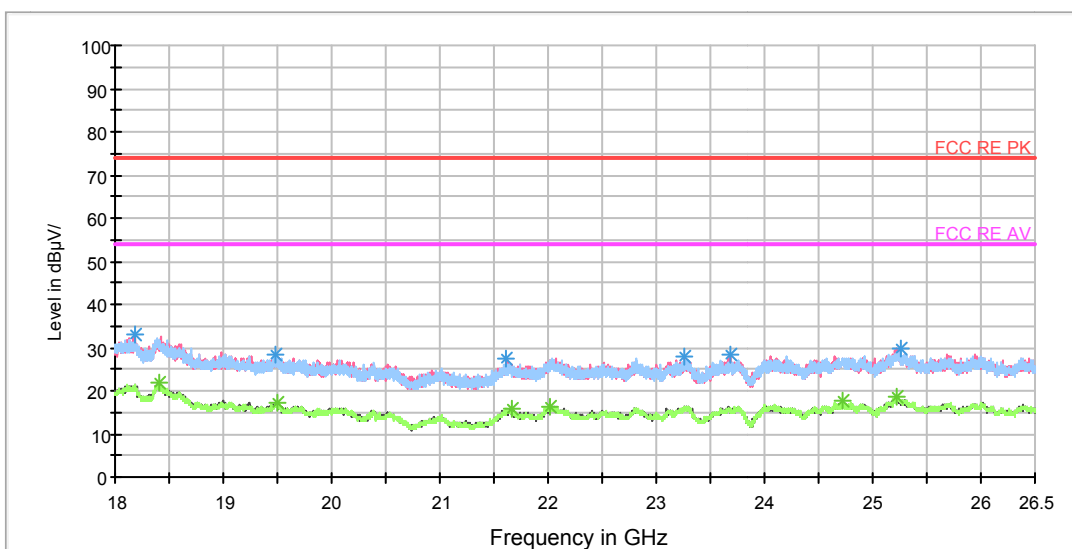

Radiated Emission from 18GHz to 26.5GHz

Frequency (MHz)	Peak (dBuV/m)	Reading value (dBuV/m)	Polarization	Azimuth (deg)	Correct Factor (dB)	Margin (dB)	Limit (dBuV/m)
18176.375000	32.9	37.9	V	128.0	-5.0	41.1	74
19489.625000	28.2	35.8	H	0.0	-7.6	45.8	74
21607.187500	27.5	36.3	V	73.0	-8.8	46.5	74
23261.500000	28.1	35.5	V	166.0	-7.4	45.9	74
23687.562500	28.5	37.0	V	128.0	-8.5	45.5	74
25252.625000	29.9	36.6	H	97.0	-6.7	44.1	74

Frequency (MHz)	Average (dBuV/m)	Reading value (dBuV/m)	Polarization	Azimuth (deg)	Correct Factor (dB)	Margin (dB)	Limit (dBuV/m)
18404.812500	21.8	26.8	H	114.0	-5.0	32.2	54
19493.875000	17.2	24.8	V	57.0	-7.6	36.8	54
21660.312500	15.7	24.9	H	58.0	-9.2	38.3	54
22020.500000	16.5	24.5	H	0.0	-8.0	37.5	54
24720.312500	17.5	23.8	H	19.0	-6.3	36.5	54
25213.312500	18.6	24.8	H	105.0	-6.2	35.4	54

3.2 Conducted Emission

Ambient condition

Temperature	Relative humidity	Pressure
24°C ~26°C	50%~55%	102.5kPa

Methods of Measurement

The EUT is placed on a non-metallic table of 80cm height above the horizontal metal reference ground plane. During the test, the EUT was operating in its typical mode. The test method is according to ANSI C63.4-2014. Connect the AC power line of the EUT to the L.I.S.N. Use EMI receiver to detect the average and Quasi-peak value. RBW is set to 9 kHz, VBW is set to 30kHz. The measurement result should include both L line and N line.

During the test, EUT is connected to a laptop via a USB cable in the case of Transfer Data mode. The EUT is used as the peripheral equipment of the PC. The data is transferred from EUT to PC; PC is connected to server via a long LAN cable.

Test Setup

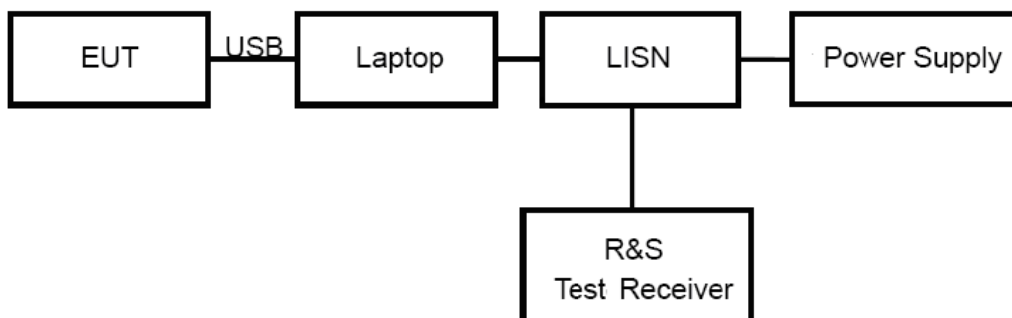

Note: Power Supply is AC Power source and it is used to change the voltage 120V/60Hz.

Limits

Frequency (MHz)	Conducted Limits(dBμV)	
	Quasi-peak	Average
0.15 - 0.5	66 to 56 *	56 to 46 *
0.5 - 5	56	46
5 - 30	60	50

*: Decreases with the logarithm of the frequency.

Measurement Uncertainty

The assessed measurement uncertainty to ensure 95% confidence level for the normal distribution is with the coverage factor $k = 1.96$. $U = 2.69$ dB.

Test Results

Following plots, Blue trace uses the peak detection; Green trace uses the average detection.

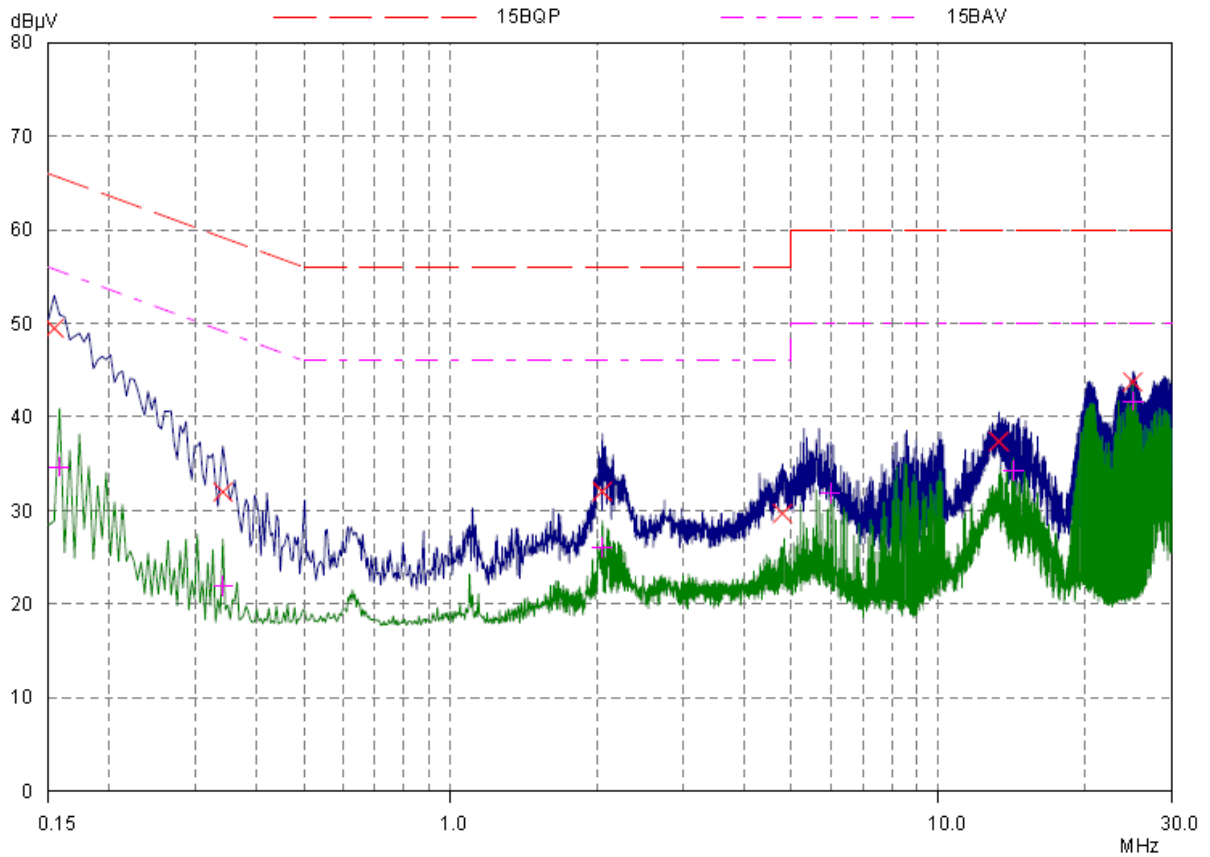

Final Measurement Results

Frequency MHz	QP Level dBµV	QP Limit dBµV	QP Delta dB	Phase -	PE -
0.1539	49.46	65.79	16.33	L1	gnd
0.3414	31.97	59.17	27.20	L1	gnd
2.04453	32.02	56.00	23.98	L1	gnd
4.79062	29.68	56.00	26.32	L1	gnd
13.28671	37.39	60.00	22.61	L1	gnd
25.05234	43.74	60.00	16.26	L1	gnd

Frequency MHz	AV Level dBµV	AV Limit dBµV	AV Delta dB	Phase -	PE -
0.15781	34.68	55.58	20.90	L1	gnd
0.3414	21.99	49.17	27.18	L1	gnd
2.04453	26.06	46.00	19.94	L1	gnd
6.00156	31.83	50.00	18.17	L1	gnd
14.22031	34.25	50.00	15.75	L1	gnd
25.05234	41.68	50.00	8.32	L1	gnd

L line

Conducted Emission from 150 KHz to 30 MHz

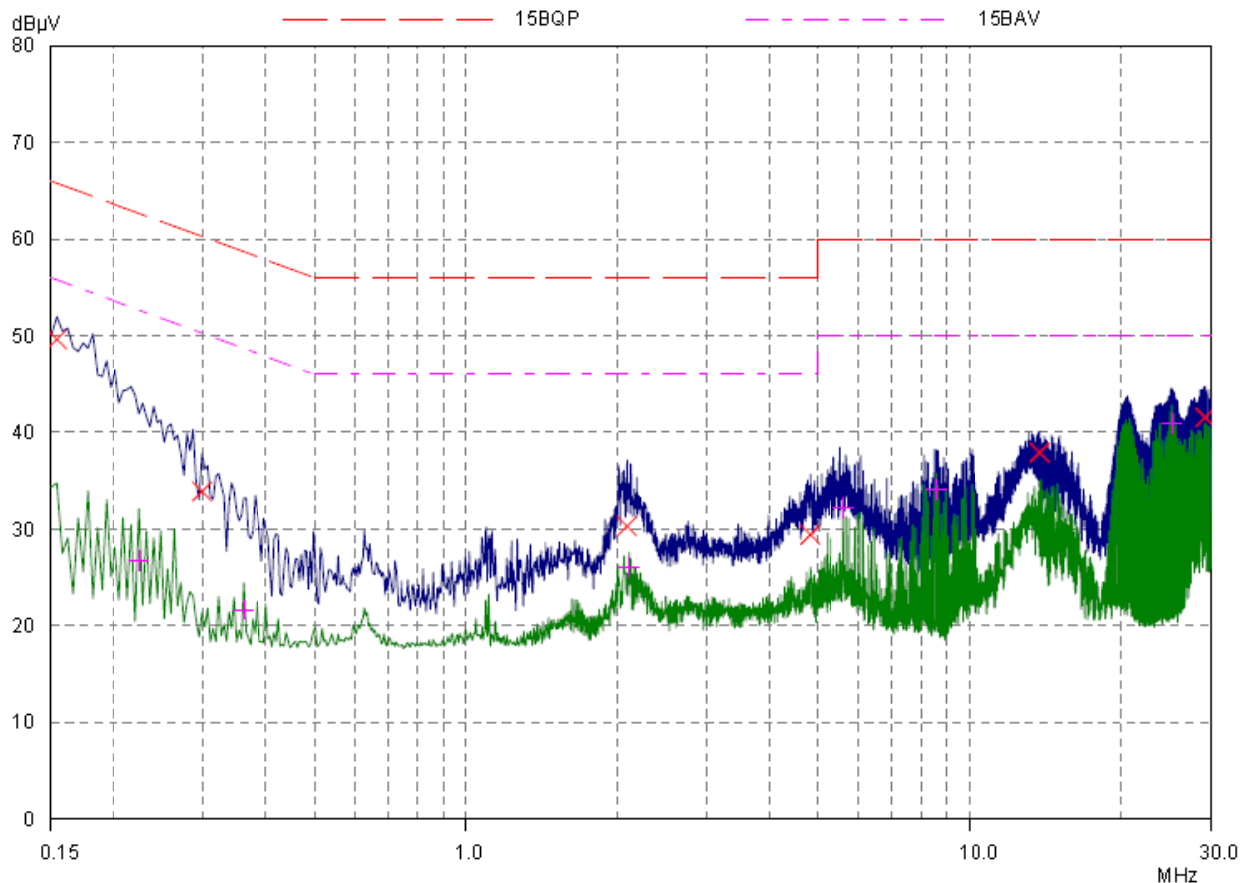

Final Measurement Results

Frequency MHz	QP Level dBµV	QP Limit dBµV	QP Delta dB	Phase -	PE -
0.1539	49.62	65.79	16.17	N	gnd
0.29843	33.90	60.29	26.39	N	gnd
2.0875	30.30	56.00	25.70	N	gnd
4.82187	29.42	56.00	26.58	N	gnd
13.75546	37.91	60.00	22.09	N	gnd
29.26328	41.54	60.00	18.46	N	gnd

Frequency MHz	AV Level dBµV	AV Limit dBµV	AV Delta dB	Phase -	PE -
0.22421	26.76	52.66	25.90	N	gnd
0.36093	21.66	48.71	27.05	N	gnd
2.10703	26.06	46.00	19.94	N	gnd
5.61093	32.22	50.00	17.78	N	gnd
8.57187	34.11	50.00	15.89	N	gnd
25.20859	40.92	50.00	9.08	N	gnd

N line
Conducted Emission from 150 KHz to 30 MHz

4 Main Test Equipment

Name	Type	Manufacturer	Serial Number	Last Cal.	Cal. Due Date
EMI Test Receiver	ESCI	R&S	100948	2015-05-22	2016-05-21
Signal Analyzer	FSV30	R&S	100815	2015-12-17	2016-12-16
Trilog Antenna	VULB 9163	SCHWARZBECK	9163-201	2014-12-06	2017-12-05
Horn Antenna	HF907	R&S	100126	2014-12-06	2017-12-05
Horn Antenna	3160-09	ETS-Lindgren	00102643	2015-01-30	2018-01-29
EMI Test Receiver	ESCS30	R&S	100138	2015-12-17	2016-12-16
LISN	ENV216	R&S	101171	2013-12-18	2016-12-17
Bore Sight Antenna mast	2171B	ETS	00058752	NA	NA

ANNEX A: The EUT Appearance and Test Configuration

A.1 EUT Appearance



Front Side



Back Side

a: EUT



b: Adapter
Picture 1 EUT

A.2 Test Setup



a: Below 1GHz



b: Above 1GHz

Picture 2 Radiated Emission Test Setup



Picture 3 Conducted Emission Test Setup

A.3 Host Product

