



RF TEST REPORT

Applicant Alcatel-Lucent Shanghai Bell Co., Ltd.
FCC ID 2ADZRG240WZA
Brand NOKIA
Product Digital Home ONU
Model G-240WZ-A
Report No. YBA1604-0033RF05R1
Issue Date June 13, 2016

TA Technology (Shanghai) Co., Ltd. tested the above equipment in accordance with the requirements in **FCC CFR47 Part 15 (2015)**. The test results show that the equipment tested is capable of demonstrating compliance with the requirements as documented in this report.

Lingling Kang

Reviewed by: *lingling Kang*

Kai Xu

Approved by: *Kai Xu*



中国认可
国际互认
检测
TESTING
CNAS L2264

TA Technology (Shanghai) Co., Ltd.

No.145, Jintang Rd, Tangzhen Industry Park, Pudong Shanghai, China

TEL: +86-021-50791141/2/3

FAX: +86-021-50791141/2/3-8000

Table of Contents

1	Test Laboratory.....	4
1.1	Notes of the Test Report.....	4
1.2	Test facility.....	4
1.3	Testing Location.....	5
2	General Description of Equipment under Test.....	6
2.1	Applied Standards.....	8
3	Test Configuration.....	9
3.1	Test Mode.....	9
3.2	Occupied Bandwidth.....	10
3.3	Radiated Emissions.....	12
3.4	Conducted Emissions.....	30
4	Main Test Instruments.....	33
	ANNEX A: EUT Appearance and Test Setup.....	34
	A.1 EUT Appearance.....	34
	A.2 Test Setup.....	35

Summary of Measurement Results

Number	Summary of measurements of results	Clause in FCC rules	Verdict
1	Occupied Bandwidth (20dB)	15.215	PASS
2	Radiated Emissions	15.249(a),15.249(c),15.249(d),15.209,15.205;	PASS
3	AC Power Line Conducted Emissions	15.207;	PASS
Date of Testing: April 12, 2016~ May 14, 2016			

1 Test Laboratory

1.1 Notes of the Test Report

This report shall not be reproduced in full or partial, without the written approval of TA technology (shanghai) co., Ltd. The results documented in this report apply only to the tested sample, under the conditions and modes of operation as described herein. Measurement Uncertainties were not taken into account and are published for informational purposes only. This report is written to support regulatory compliance of the applicable standards stated above. This report must not be used by the client to claim product certification, approval, or endorsement by CNAS or any government agencies.

1.2 Test facility

CNAS (accreditation number: L2264)

TA Technology (Shanghai) Co., Ltd. has obtained the accreditation of China National Accreditation Service for Conformity Assessment (CNAS).

FCC (recognition number is 428261)

TA Technology (Shanghai) Co., Ltd. has been listed on the US Federal Communications Commission list of test facilities recognized to perform electromagnetic emissions measurements.

IC (recognition number is 8510A)

TA Technology (Shanghai) Co., Ltd. has been listed by industry Canada to perform electromagnetic emission measurement.

A2LA(Certificate Number: 3857.01)

TA Technology (Shanghai) Co., Ltd. has been listed by American Association for Laboratory Accreditation to perform electromagnetic emission measurement.

1.3 Testing Location

Company: TA Technology (Shanghai) Co., Ltd.
Address: No.145, Jintang Rd, Tangzhen Industry Park, Pudong Shanghai, China
City: Shanghai
Post code: 201201
Country: P. R. China
Contact: Xu Kai
Telephone: +86-021-50791141/2/3
Fax: +86-021-50791141/2/3-8000
Website: <http://www.ta-shanghai.com>
E-mail: xukai@ta-shanghai.com

2 General Description of Equipment under Test

Client Information

Applicant	Alcatel-Lucent Shanghai Bell Co.,Ltd.
Applicant address	388-389#,Ningqiao Road,Pudong Jinqiao, Shanghai P.R. China
Manufacturer	Taicang T&W Electronics Co.,Ltd
Manufacturer address	Jiangnan Road 89,Ludu Town, Taicang P.R. China

General information

Model:	G-240WZ-A
IMEI:	/
HW Version:	PEM 1+
SW Version:	3FE45890FFEB38
Power Supply:	DC voltage supplied from AC adapter
Antenna Type:	ExternalAntenna
Test Mode(s):	z-wave
Tested Frequency Range(s):	908.4 MHz, 908.42 MHz, 916.00 MHz
Modulation Type:	FSK、GFSK
Data rate:	9.6 kbps, 40 kbps, 100 kbps
Note: The information of the EUT is declared by the manufacturer. Please refer to the specifications or user manual for details.	

Configurations

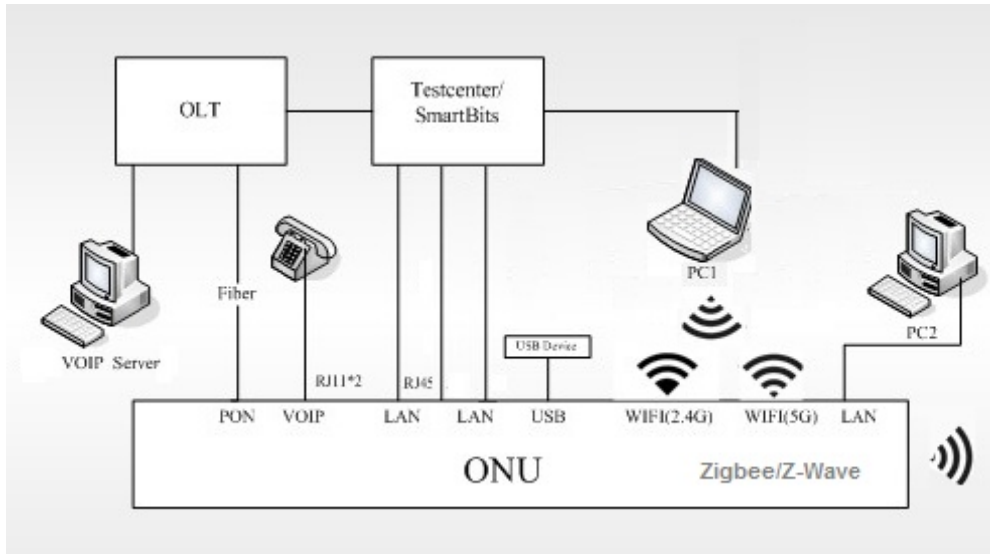

No.	Name	Model/Code No.	Edition	Serial No. or Quantity
1	G-240WZ-A	3FE 45688AABA	PEM1	N.A
3	Power adapter	UES36-120300SPA1	01	N.A

Auxiliary Equipment

No.	Name	Brand name	Model	ASB code	Valid Until
1	SmartBits	Spirent	SMB600B	N.A	N.A
2	OLT	Alcatel-Lucent	7360 ISAM FX-4	N.A	N.A
3	Phone	N.A	N.A	N.A	N.A
4	Computer	N.A	N.A	N.A	N.A

Port description

No.	Port name	Number	Shielded or unshielded	Cable type (optic, twisted pair, etc.)	Max. Cable length
1	AC power	1	N.A	N.A	N.A
2	Gigabit Ethernet	4	Unshielded	Multi twisted pair	N.A
3	POTS	2	unshielded	Twisted pair	N.A
4	PON	1	unshielded	Optic	N.A
5	USB	2	shielded	Twisted pair	N.A



2.1 Applied Standards

According to the specifications of the manufacturer, it must comply with the requirements of the following standards:

Test standards

FCC CFR47 Part 15C (2015)Radio Frequency Devices

ANSI C63.10 (2013)

3 Test Configuration

3.1 Test Mode

The EUT has been associated with peripherals and configuration operated in a manner tended to maximize its emission characteristics in a typical application.

The radiated emission was measured in the following position: EUT stand-up position (Z axis), lie-down position (X, Y axis). The worst emission was found in lie-down position (X axis) and the worst case was recorded.

3.2 Occupied Bandwidth

Ambient condition

Temperature	Relative humidity	Pressure
23°C ~25°C	45%~50%	101.5kPa

Method of Measurement

Tests are performed in accordance with ANSI C63.10-2013.

The 20 dB and 99% bandwidth of the fundamental frequency remain inside the band of operation of 902-928 MHz. The EUT was connected to the spectrum analyzer and z-wave test set via a power splitter with a known loss. The occupied bandwidth is measured using spectrum analyzer. RBW is set to 10 kHz and VBW is set to 30 kHz on spectrum analyzer.

Test Setup

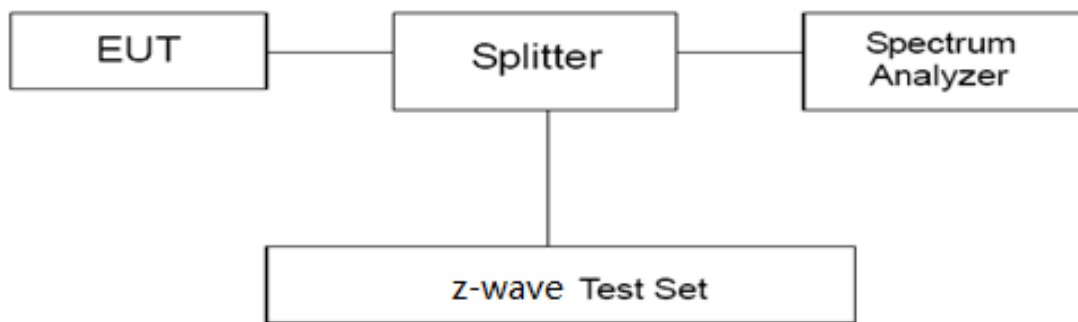

Limits

No specific occupied bandwidth requirements in part 15.215(c).

Measurement Uncertainty

The assessed measurement uncertainty to ensure 95% confidence level for the normal distribution is with the coverage factor $k = 2$. $U = 1.19$ dB

Test Results

Mode	Frequency (MHz)	Rate (kbit)	20dB Bandwidth(kHz)	99% Bandwidth(kHz)
z-wave	908.40	40	103.6	95.934
	908.42	9.6	108.3	99.022
	916	100	132.7	118.44

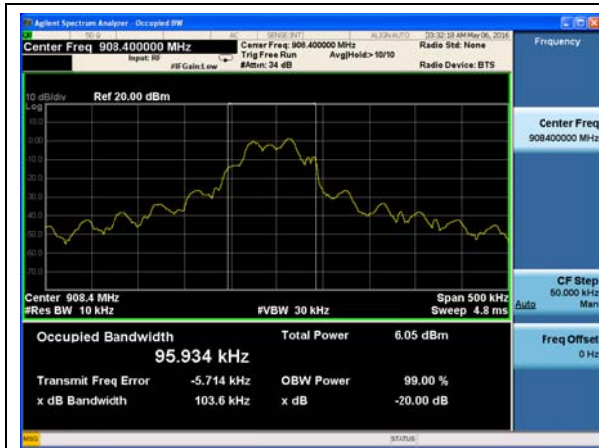

Carrier frequency (MHz): 908.4 (40kbit)

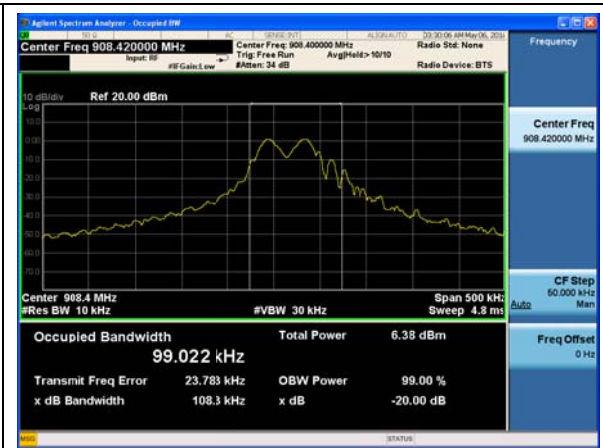

Carrier frequency (MHz): 908.42 (9.6kbit)

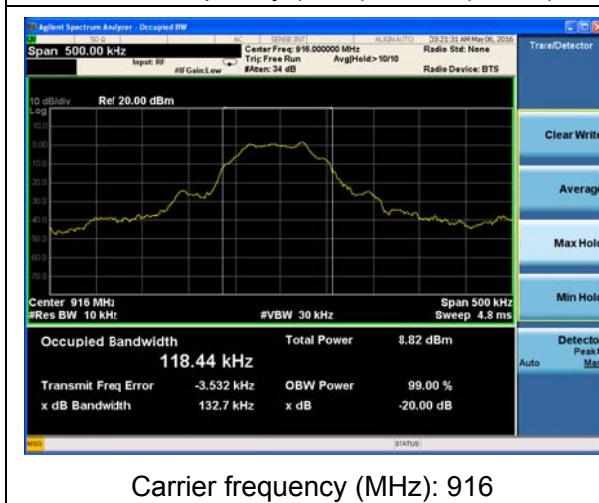

Carrier frequency (MHz): 916

3.3 Radiated Emissions

Ambient condition

Temperature	Relative humidity	Pressure
23°C ~25°C	45%~50%	101.5kPa

Method of Measurement

The test set-up was made in accordance to the general provisions of ANSI C63.10-2013. The Equipment Under Test (EUT) was set up on a non-conductive table in the semi-anechoic chamber. The test was performed at the distance of 3 m between the EUT and the receiving antenna. The radiated emissions measurements were made in a typical installation configuration.

Sweep the whole frequency band through the range from 9 kHz to the 10th harmonic of the carrier, and the emissions less than 20 dB below the permissible value are reported.

During the test, below 30MHz, the center of the loop shall be 1 meters; above 30MHz, the height of receive antenna shall be moved from 1 to 4 meters, and the antenna shall be performed under horizontal and vertical polarization. The turntable shall be rotated from 0 to 360 degrees for detecting the maximum of radiated spurious signal level. The measurements shall be repeated with orthogonal polarization of the test antenna. The data of cable loss and antenna factor has been calibrated in full testing frequency range before the testing.

Set the spectrum analyzer in the following:

Below 1GHz (detector: Peak and Quasi-Peak)

RBW=100kHz / VBW=300kHz / Sweep=AUTO

Above 1GHz(detector: Peak):

(a) PEAK: RBW=1MHz VBW=3MHz/ Sweep=AUTO

(b) AVERAGE: RBW=1MHz / VBW=3MHz / Sweep=AUTO

The radiated emission was measured in the following position: EUT stand-up position (Z axis), lie-down position (X, Y axis). The worst emission was found in stand-up position (Z axis) and the worst case was recorded. Then this mode was measured in the following mode: EUT with cradle and EUT without cradle. The worst emission was found in EUT with cradle mode and the worst case was recorded.

The test is in transmitting mode.

Test setup
9KHz~~~ 30MHz

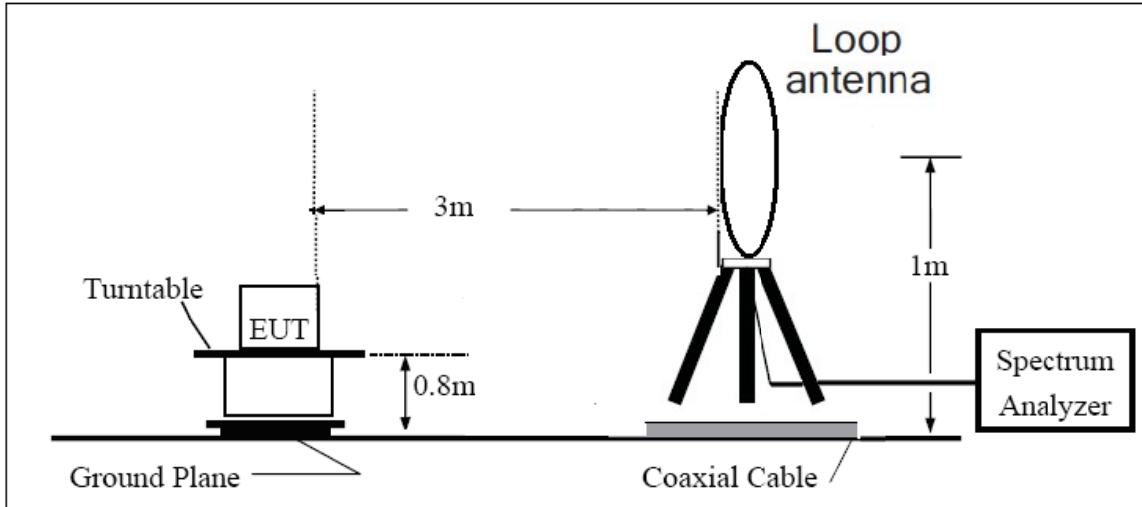

30MHz~~~ 1GHz

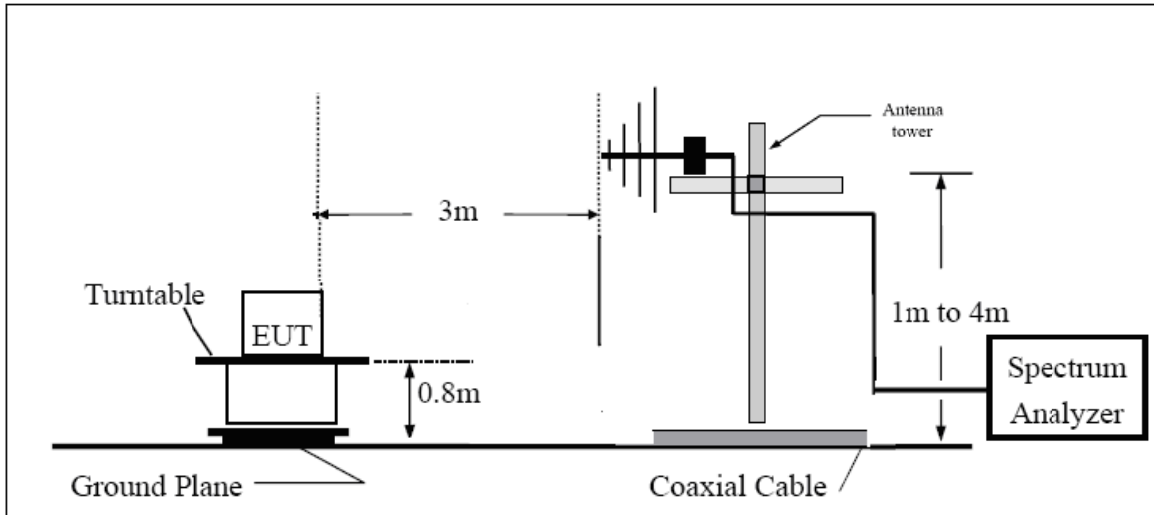

Above 1GHz

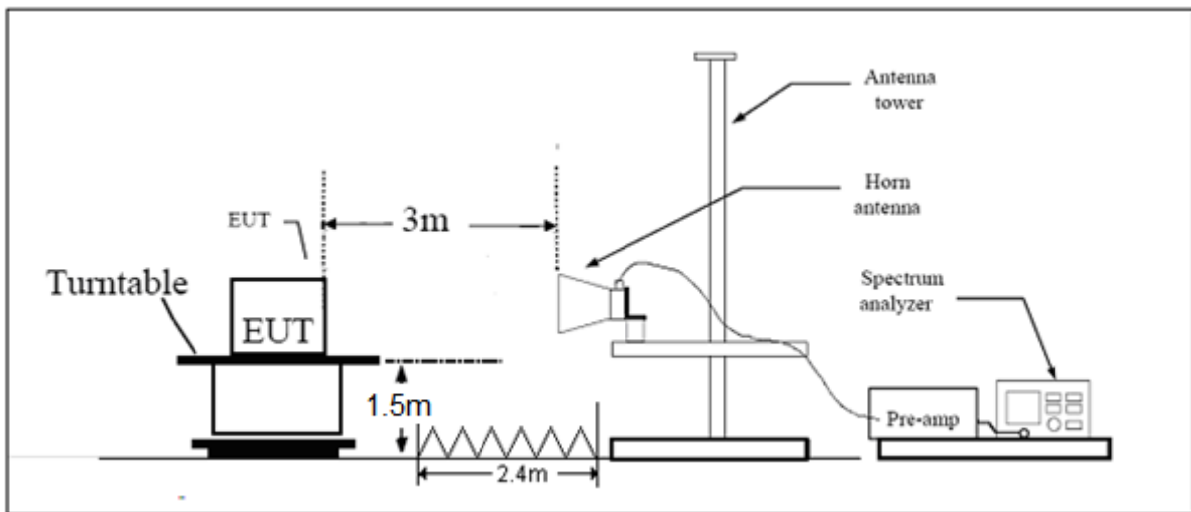

Limits

Limit in restricted band(Part 15.209)

Frequency of emission (MHz)	Field strength(uV/m)	Field strength(dBuV/m)
0.009–0.490	2400/F(kHz)	/
0.490–1.705	24000/F(kHz)	/
1.705–30.0	30	/
30-88	100	40
88-216	150	43.5
216-960	200	46
Above960-1000	500	54

Limit in radiated emission measurement (Part 15.209)

Frequency of emission (MHz)	Field strength(dBuV/m) @3m	
Above 1000	74 (peak)	54(average)

Limit in radiated emission measurement (Part 15.249)

Frequency of emission (MHz)	Field strength of fundamental @3m	
	(millivolts/meter)	(dBuV/m)
902-928 MHz fundamental	50	94
902-928 MHzharmonics	500	

Measurement Uncertainty

The assessed measurement uncertainty to ensure 95% confidence level for the normal distribution is with the coverage factor $k = 1.96$.

Frequency	Uncertainty
9KHz-30MHz	3.55 dB
30MHz-200MHz	4.19 dB
200MHz-1GHz	3.63 dB
Above 1GHz	3.68 dB



Test Results:

Fundamental Field Strength

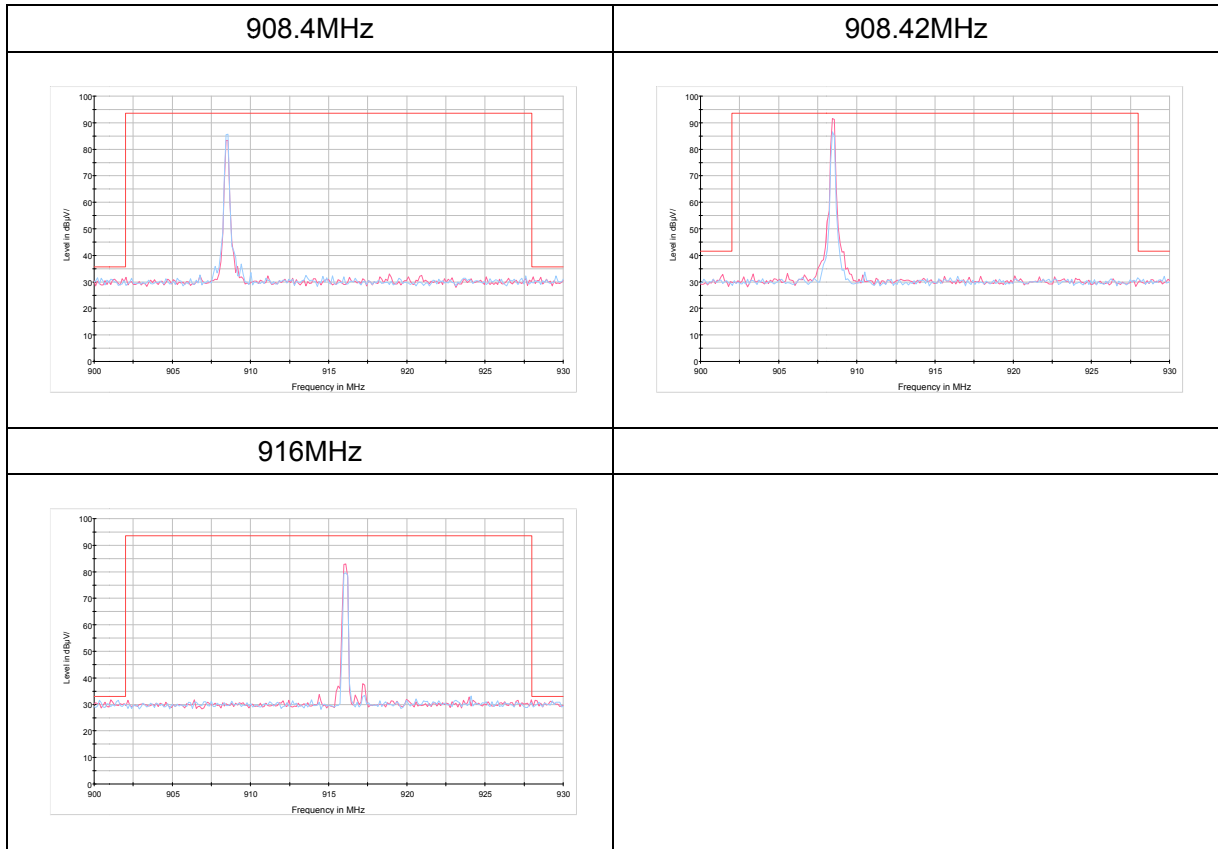



Band edge

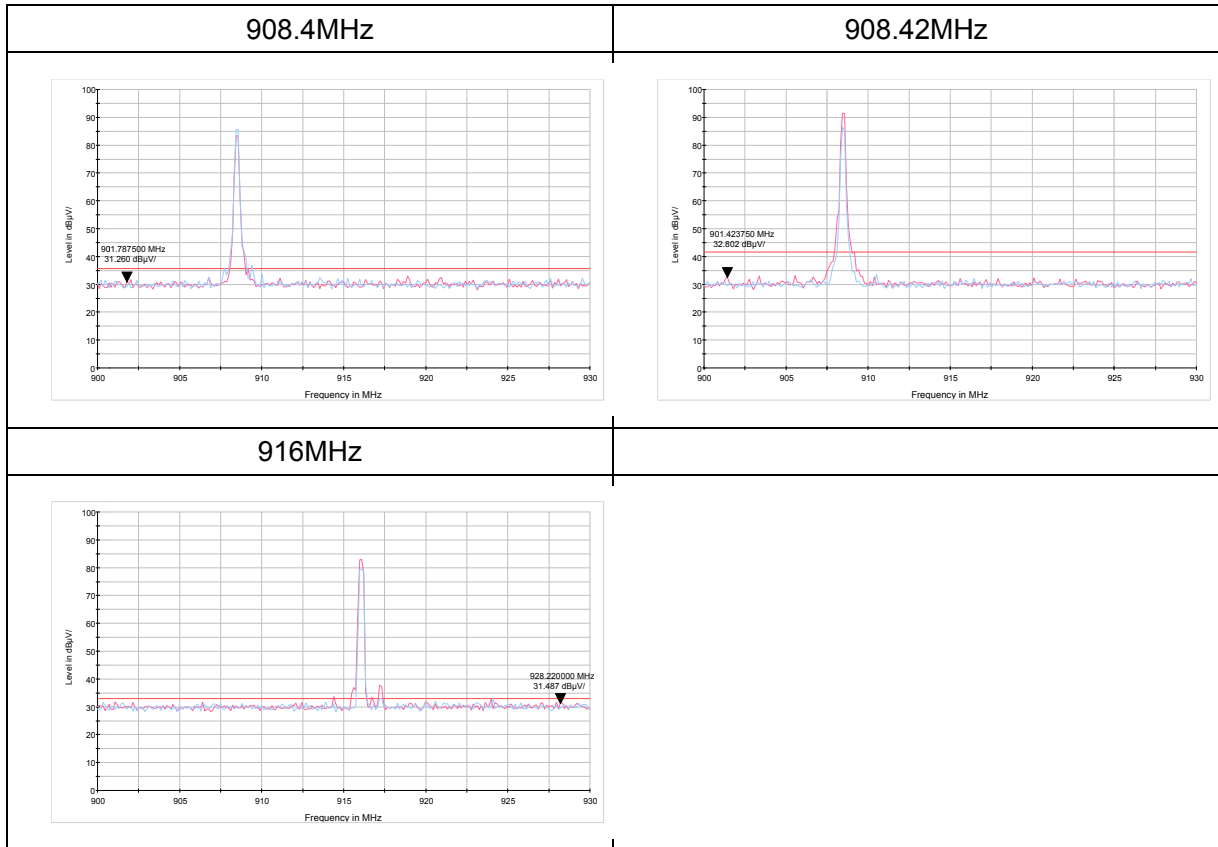



908.4MHz

FCC RE 9K-90KHz AV

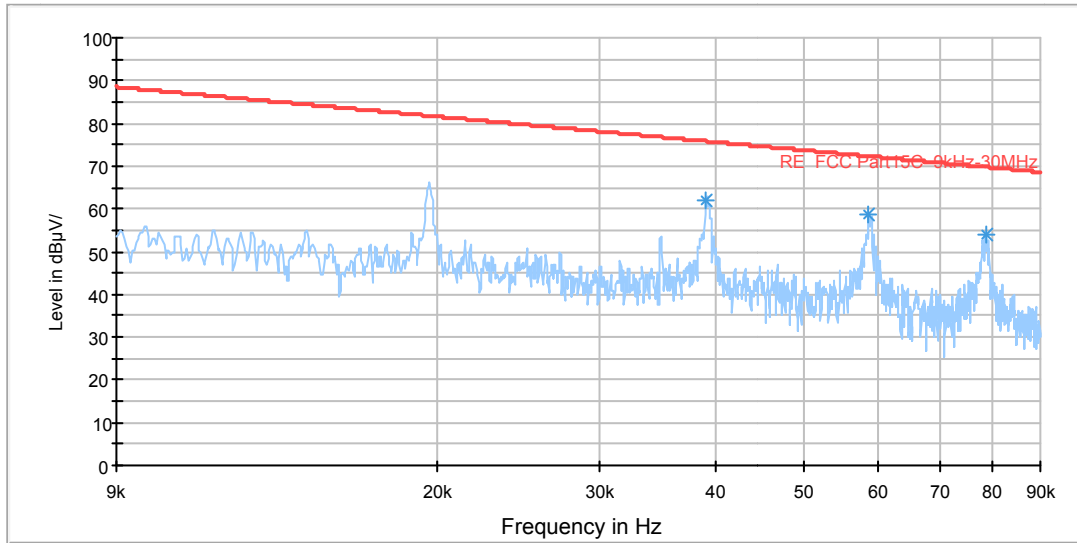

Radiated Emission 9K-90KHz

Frequency (MHz)	Average (dBuV/m)	Reading value (dBuV/m)	Height (cm)	Azimuth (deg)	Correct Factor (dB)	Margin (dB)	Limit (dBuV/m)
0.039213	62.2	90.3	100.0	0.0	28.1	13	75.8
0.058694	58.9	86.2	100.0	0.0	27.3	13.37	72.27
0.078741	54.1	79.5	100.0	0.0	25.4	15.8	69.9

FCC RE 90K-110KHz QP

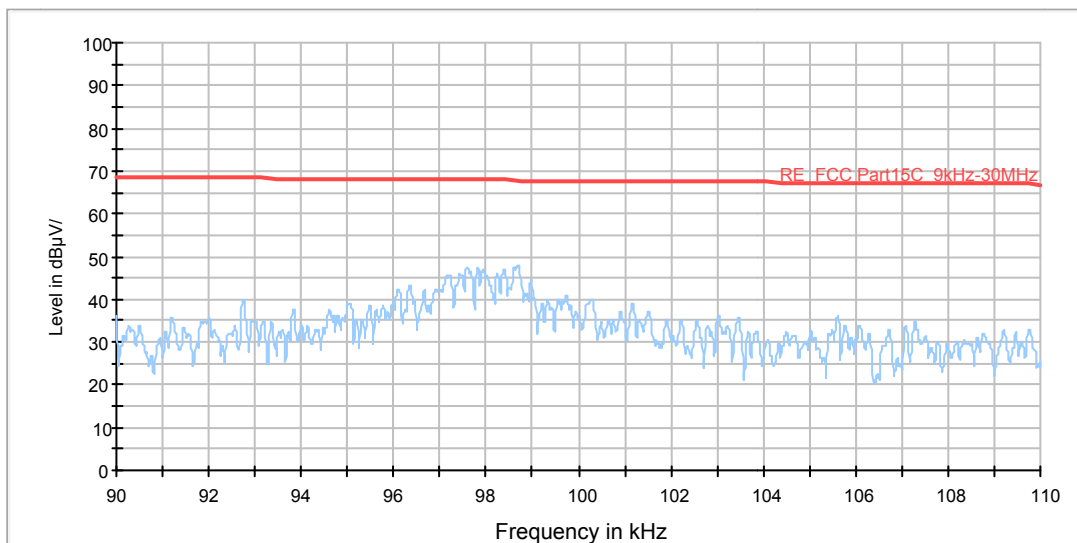

Radiated Emission 90K-110KHz

FCC RE 110K-490KHz AV

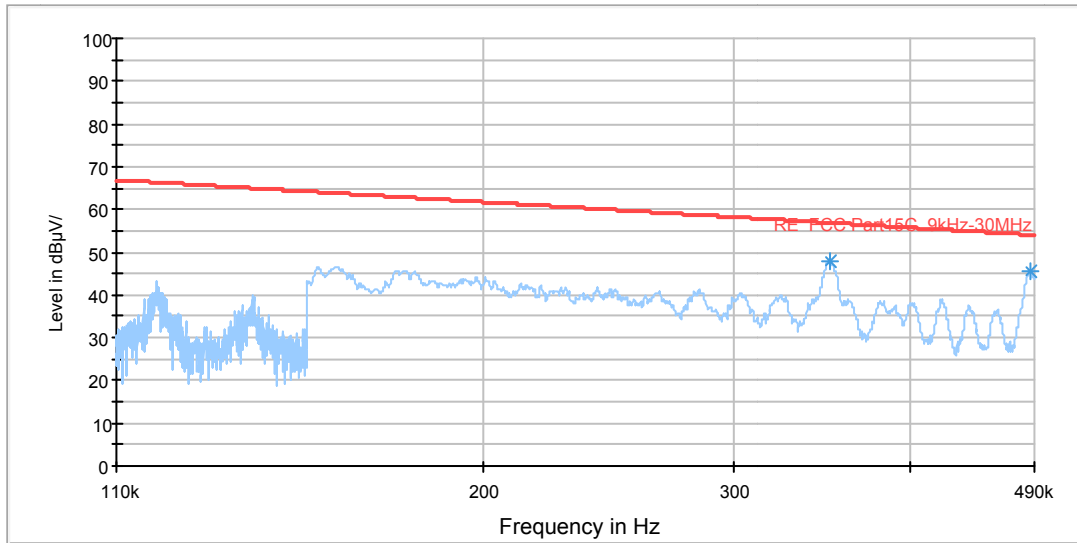

Radiated Emission 110KHz-490KHz

Frequency (MHz)	Average (dBuV/m)	Reading value (dBuV/m)	Height (cm)	Azimuth (deg)	Correct Factor(dB)	Margin (dB)	Limit (dBuV/m)
0.351620	47.8	68.3	100.0	0.0	20.5	9.07	56.87
0.486770	45.6	65.4	100.0	0.0	19.8	8.49	54.09

FCC RE 490K-30MHz QP

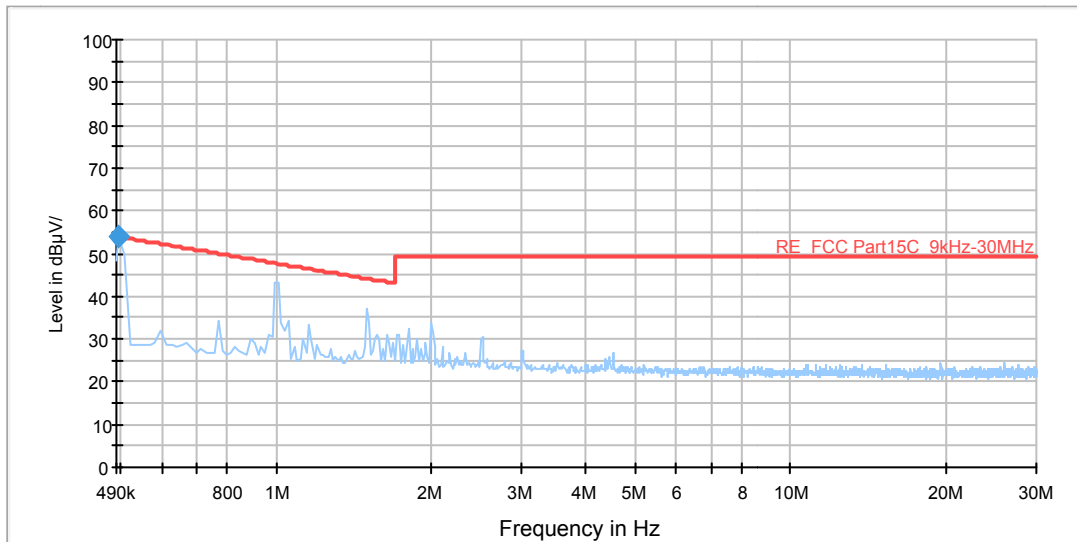

Radiated Emission 490K-30MHz

Frequency (MHz)	Quasi-Peak (dBuV/m)	Reading value (dBuV/m)	Height (cm)	Polarization	Azimuth (deg)	Correct Factor(dB)	Margin (dB)	Limit (dBuV/m)
0.494	53.0	72.7	100	V	0.0	19.7	0.7	53.7

FCC RE 0.03-1GHz QP Class B

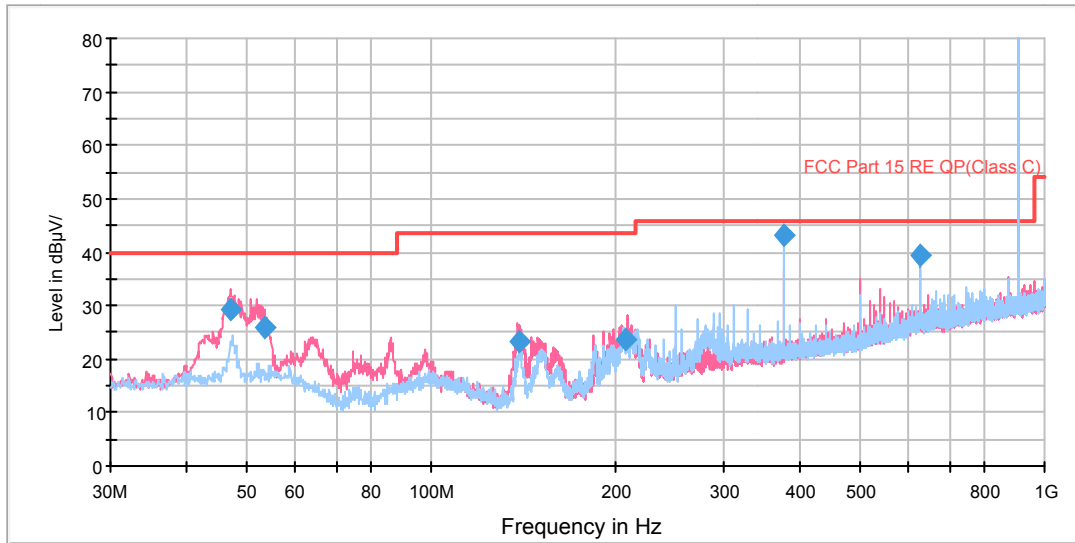

Note: The signal beyond the limit is carrier.

Radiated Emission 30M-1GHz

Frequency (MHz)	Quasi-Peak (dBuV/m)	Reading value (dBuV/m)	Height (cm)	Polarization	Azimuth (deg)	Correct Factor (dB)	Margin (dB)	Limit (dBuV/m)
47.296250	29.1	42.1	114.0	V	24.0	13.0	10.9	40.0
53.650000	25.8	38.6	100.0	V	291.0	12.8	14.2	40.0
139.078750	23.4	32.3	100.0	V	0.0	8.9	20.1	43.5
208.001250	23.8	36.2	100.0	V	0.0	12.4	19.7	43.5
374.996250	43.1	60.5	100.0	H	178.0	17.4	2.9	46.0
625.015000	39.4	61.6	100.0	V	120.0	22.2	6.6	46.0

- Remark: 1. Quasi-Peak = Reading value + Correction factor
 2. Correction Factor = Antenna factor+ Insertion loss(cable loss+amplifier gain)
 3. Margin = Limit – Quasi-Peak

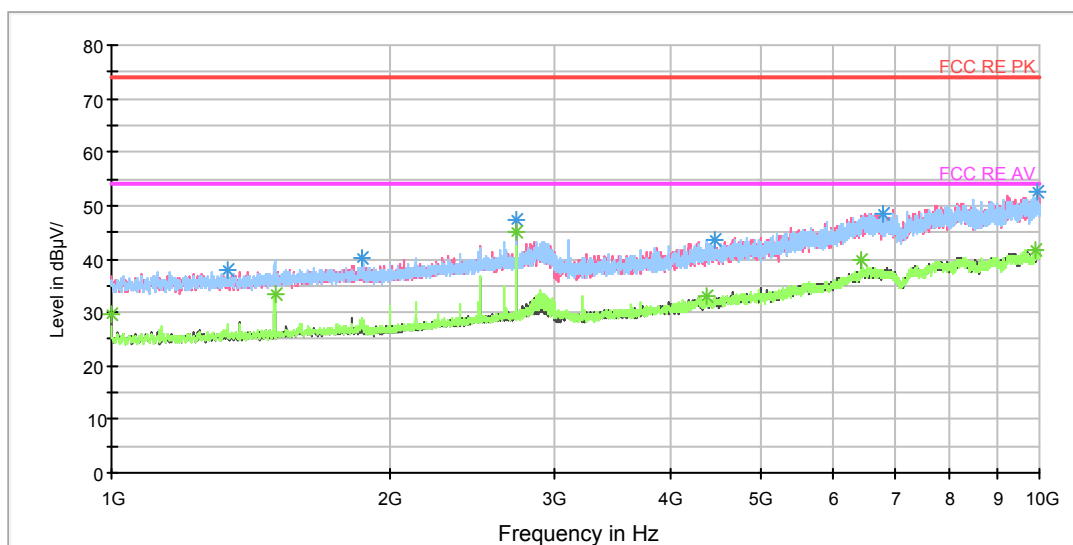

Radiated Emission 1G-10GHz

Frequency (MHz)	Peak (dBuV/m)	Reading value (dBuV/m)	Height (cm)	Polarization	Azimuth (deg)	Correct Factor (dB)	Margin (dB)	Limit (dBuV/m)
1332.000000	37.8	47.8	100.0	H	17.0	-10.0	36.2	74
1866.000000	40.3	48.5	100.0	H	2.0	-8.2	33.7	74
2725.500000	47.5	51.9	100.0	V	191.0	-4.4	26.5	74
4468.250000	43.6	44.7	100.0	H	0.0	-1.1	30.4	74
6794.000000	48.6	53.6	100.0	V	0.0	5.0	25.4	74
9956.250000	52.7	64.2	100.0	V	0.0	11.5	21.3	74

Frequency (MHz)	Average (dBuV/m)	Reading value (dBuV/m)	Height (cm)	Polarization	Azimuth (deg)	Correct Factor (dB)	Margin (dB)	Limit (dBuV/m)
1000.000000	29.7	41.1	100.0	V	22.0	-11.4	24.3	54
1500.000000	33.3	42.8	100.0	H	26.0	-9.5	20.7	54
2725.500000	45.1	49.5	100.0	V	191.0	-4.4	8.9	54
4386.000000	33.1	34.1	100.0	H	0.0	-1.0	20.9	54
6431.750000	40.0	45.1	100.0	V	0.0	5.1	14.0	54
9923.000000	41.8	53.3	100.0	V	0.0	11.5	12.2	54



908.42MHz

FCC RE 9K-90KHz AV

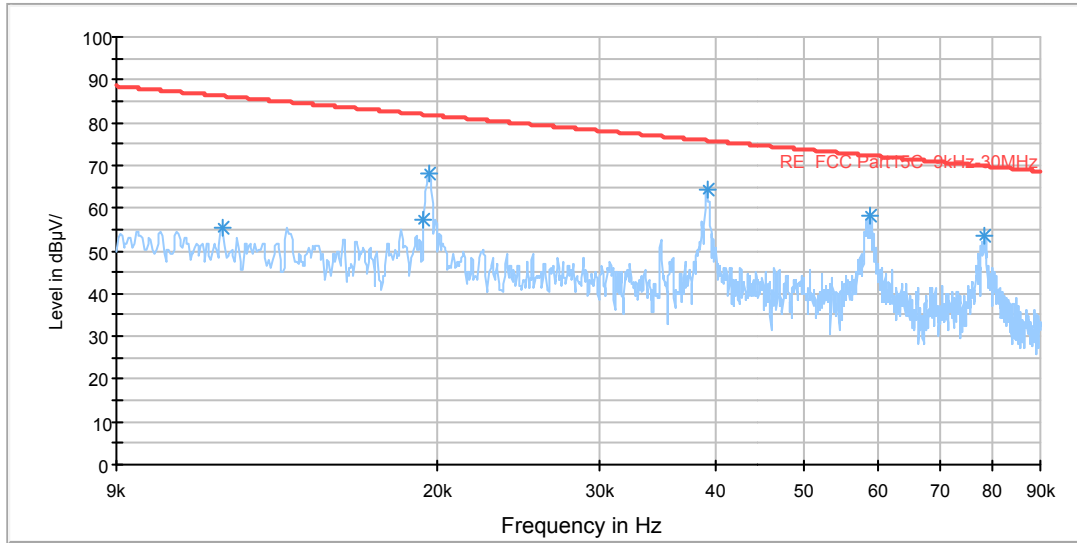

Radiated Emission 9kHz – 90kHz

Frequency (MHz)	Average (dBuV/m)	Reading value (dBuV/m)	Height (cm)	Azimuth (deg)	Correct Factor (dB)	Margin (dB)	Limit (dBuV/m)
0.011714	55.3	83.4	100.0	0.0	28.1	30.919	86.219
0.019368	57.4	85.5	100.0	0.0	28.1	24.53	81.93
0.019611	68.0	96.1	100.0	0.0	28.1	13.8	81.8
0.039294	64.1	92.2	100.0	0.0	28.1	11.7	75.8
0.058896	58.2	85.5	100.0	0.0	27.3	14.07	72.27
0.078255	53.5	78.9	100.0	0.0	25.4	16.4	69.9

FCC RE 90K-110KHz QP

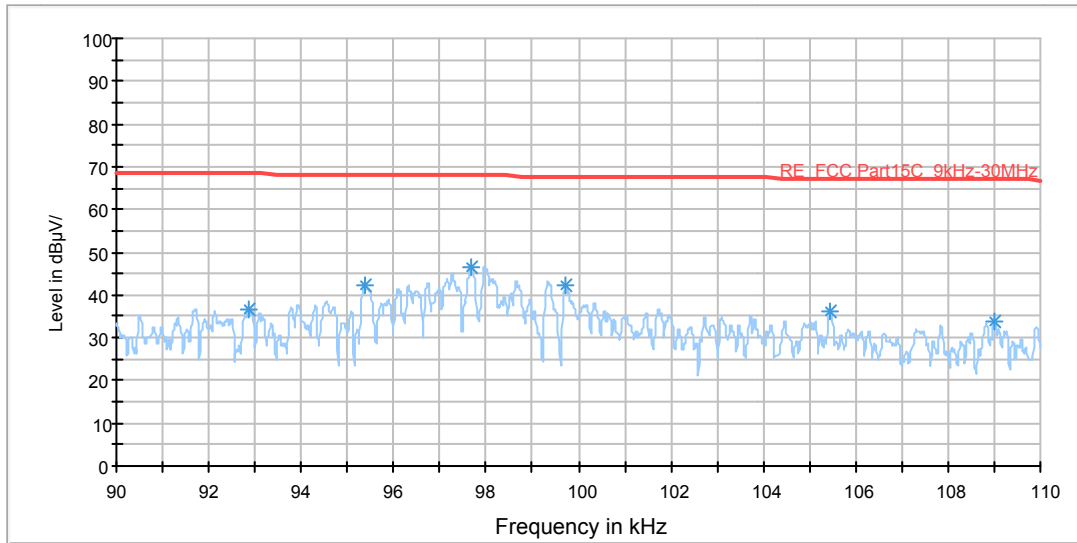

Radiated Emission 90kHz – 110kHz

FCC RE 110K-490KHz AV

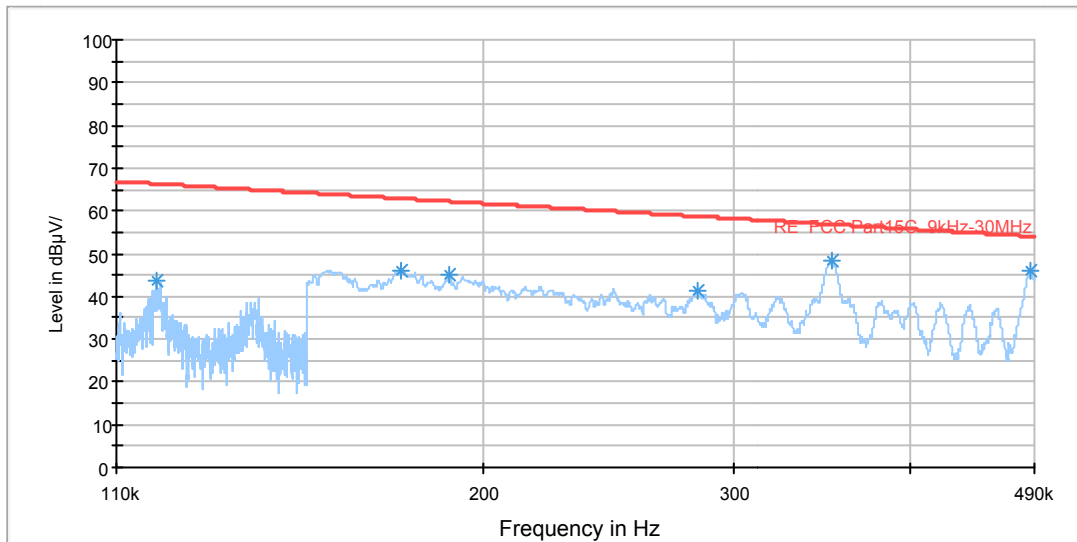

Radiated Emission 110kHz – 490kHz

Frequency (MHz)	Average (dBuV/m)	Reading value (dBuV/m)	Height (cm)	Azimuth (deg)	Correct Factor (dB)	Margin (dB)	Limit (dBuV/m)
0.352470	48.2	68.7	100.0	0.0	20.5	8.69	56.89
0.486090	45.8	65.6	100.0	0.0	19.8	8.3	54.10



FCC RE 490K-30MHz QP

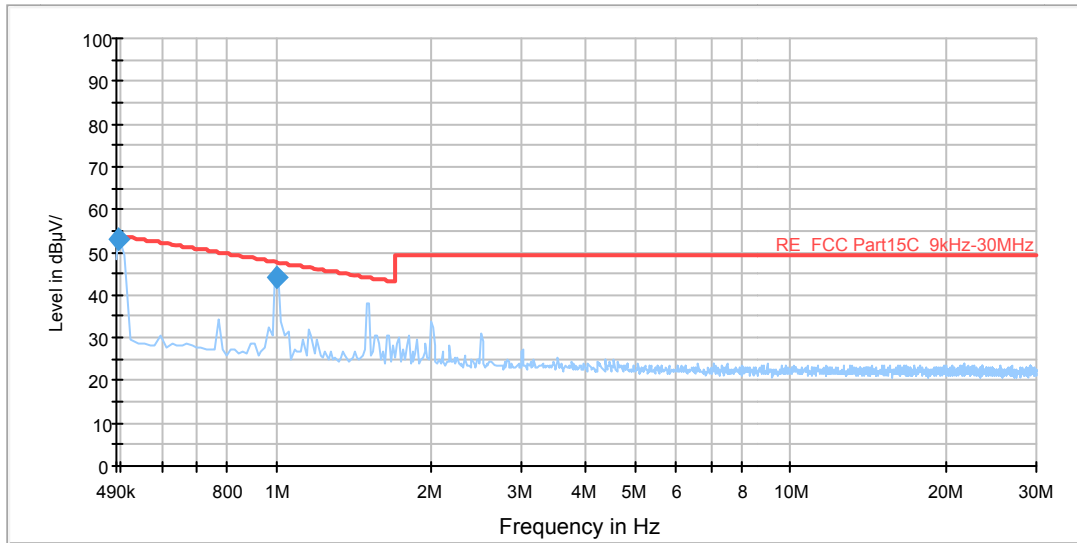

Radiated Emission 490K-30MHz

Frequency (MHz)	Quasi-Peak (dBuV/m)	Reading value (dBuV/m)	Height (cm)	Azimuth (deg)	Correct Factor (dB)	Margin (dB)	Limit (dBuV/m)
0.494325	53.0	73.3	100	0.0	20.3	0.7	53.7
1.007675	44.3	63.7	100	0.0	19.4	3.3	47.6

RE 0.03-1GHz QP Class B

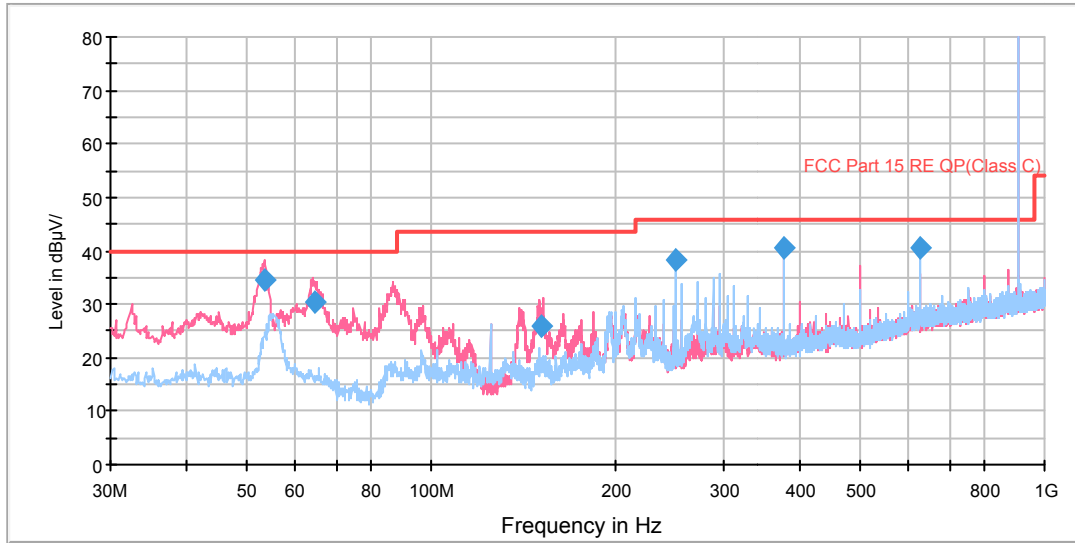

Note: The signal beyond the limit is carrier.

Radiated Emission 30M-1GHz

Frequency (MHz)	Quasi-Peak (dBuV/m)	Reading value (dBuV/m)	Height (cm)	Polarization	Azimuth (deg)	Correct Factor (dB)	Margin (dB)	Limit (dBuV/m)
53.361250	34.4	47.2	100.0	V	82.0	12.8	5.6	40.0
64.752500	30.6	41.2	100.0	V	70.0	10.6	9.4	40.0
151.417500	26.1	35.3	100.0	V	195.0	9.2	17.4	43.5
249.987500	38.2	52.3	100.0	H	20.0	14.1	7.8	46.0
374.996250	40.7	58.1	100.0	H	179.0	17.4	5.3	46.0
625.015000	40.4	62.6	114.0	H	0.0	22.2	5.6	46.0

- Remark: 1. Quasi-Peak = Reading value + Correction factor**
2. Correction Factor = Antenna factor+ Insertion loss(cable loss+amplifier gain)
3. Margin = Limit – Quasi-Peak

RE 3G-18GHz PK+AV Class B

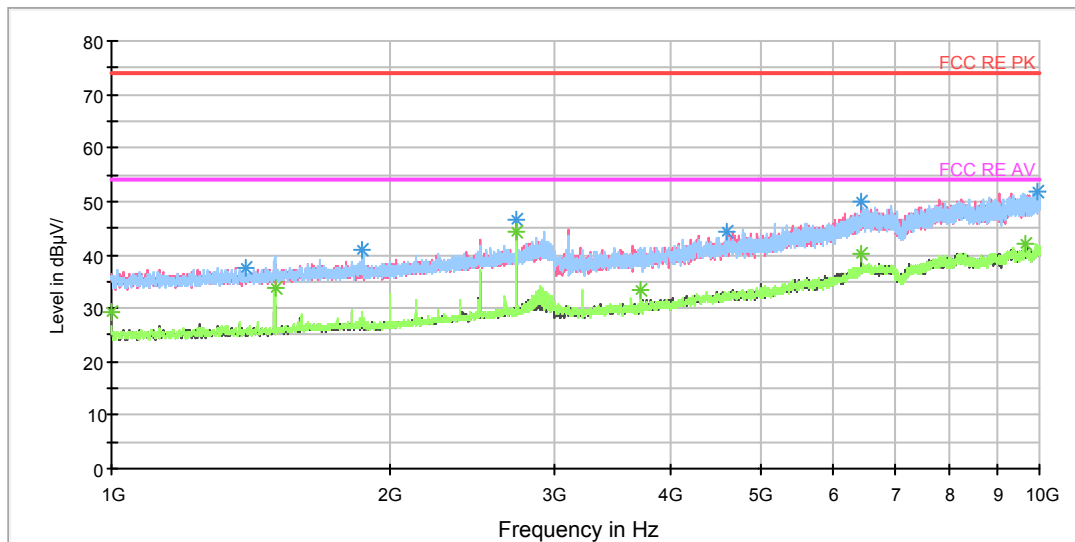

Radiated Emission 1G-10GHz

Frequency (MHz)	Peak (dBuV/m)	Reading value (dBuV/m)	Height (cm)	Polarization	Azimuth (deg)	Correct Factor (dB)	Margin (dB)	Limit (dBuV/m)
1393.000000	37.7	47.6	100.0	H	127.0	-9.9	36.3	74
1865.500000	40.8	49.0	100.0	H	6.0	-8.2	33.2	74
2725.500000	46.6	51.0	100.0	V	191.0	-4.4	27.4	74
4592.500000	44.2	45.1	100.0	H	0.0	-0.9	29.8	74
6431.750000	50.1	55.2	100.0	V	0.0	5.1	23.9	74
9966.750000	51.7	63.2	100.0	H	0.0	11.5	22.3	74

Frequency (MHz)	Average (dBuV/m)	Reading value (dBuV/m)	Height (cm)	Polarization	Azimuth (deg)	Correct Factor (dB)	Margin (dB)	Limit (dBuV/m)
1000.000000	29.1	40.5	100.0	V	323.0	-11.4	24.9	54
1500.000000	33.8	43.3	100.0	H	22.0	-9.5	20.2	54
2725.500000	44.2	48.6	100.0	V	191.0	-4.4	9.8	54
3717.500000	33.5	36.0	100.0	H	0.0	-2.5	20.5	54
6431.750000	40.1	45.2	100.0	V	0.0	5.1	13.9	54
9648.250000	42.1	53.0	100.0	H	0.0	10.9	11.9	54



916MHz

FCC RE 9K-90KHz AV

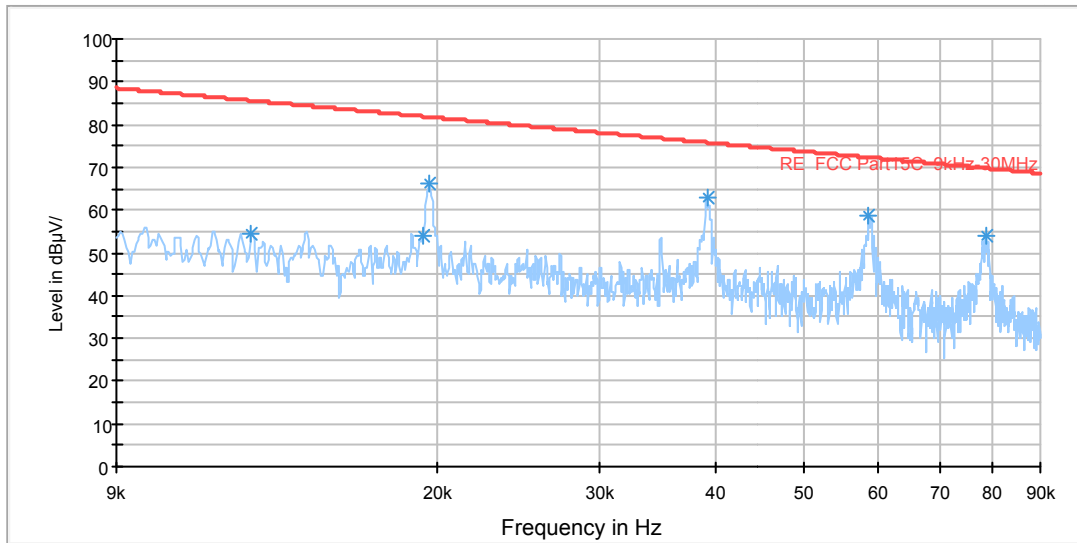

Radiated Emission 9kHz – 90kHz

Frequency (MHz)	Average (dBuV/m)	Reading value (dBuV/m)	Height (cm)	Azimuth (deg)	Correct Factor (dB)	Margin (dB)	Limit (dBuV/m)
0.039213	62.8	90.9	100.0	0.0	28.1	13	75.8
0.058694	58.9	86.2	100.0	0.0	27.3	13.37	72.27
0.078741	54.1	79.5	100.0	0.0	25.4	15.8	69.9

FCC RE 90K-110KHz QP

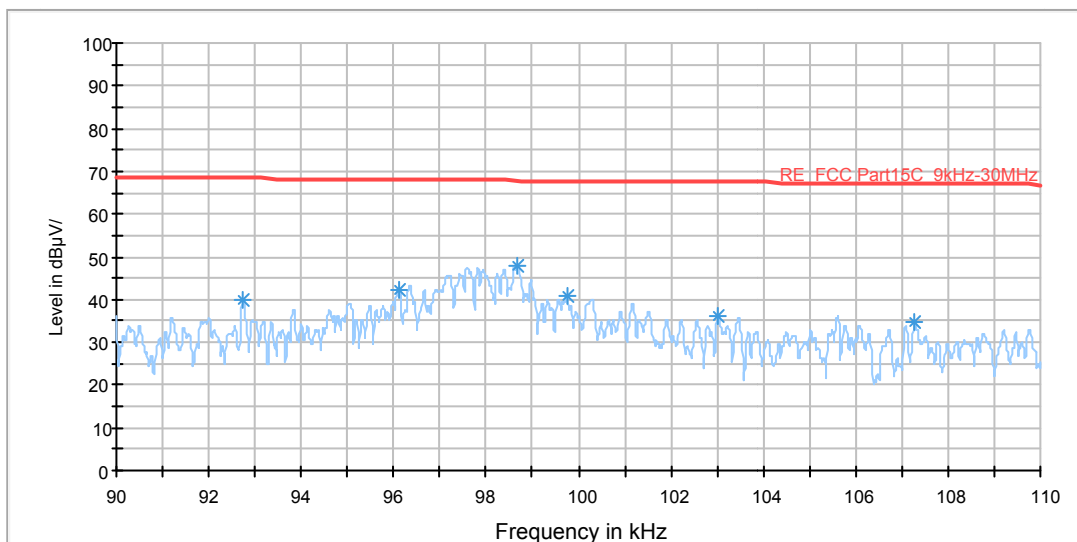

Radiated Emission 90kHz – 110kHz

FCC RE 110K-490KHz AV

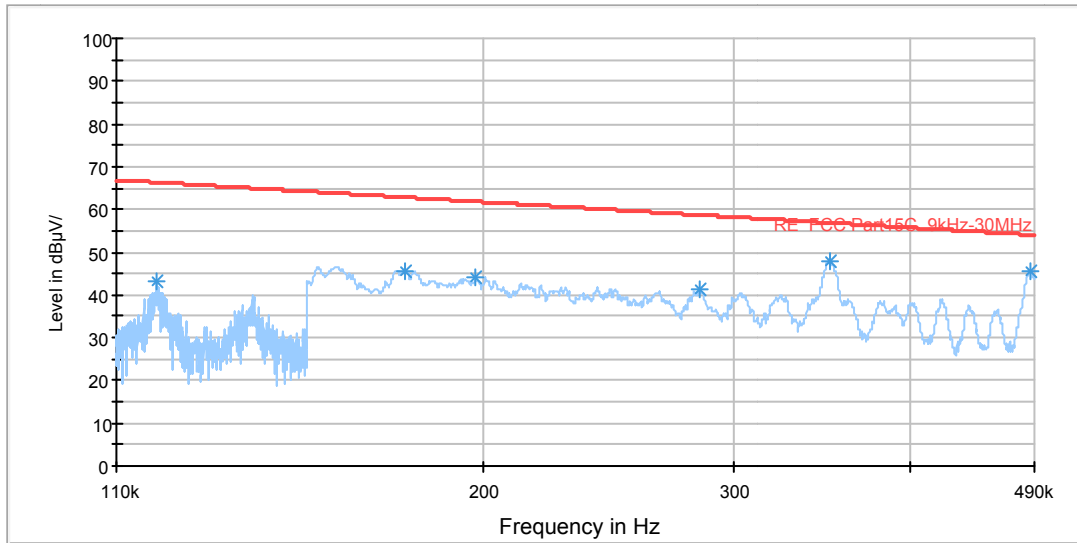

Radiated Emission 110kHz – 490kHz

Frequency (MHz)	Quasi-Peak (dBuV/m)	Reading value (dBuV/m)	Height (cm)	Azimuth (deg)	Correct Factor (dB)	Margin (dB)	Limit (dBuV/m)
0.351280	47.9	68.4	100.0	0.0	20.5	8.94	56.84
0.486770	45.6	65.4	100.0	0.0	19.8	8.46	54.06

FCC RE 490K-30MHz QP

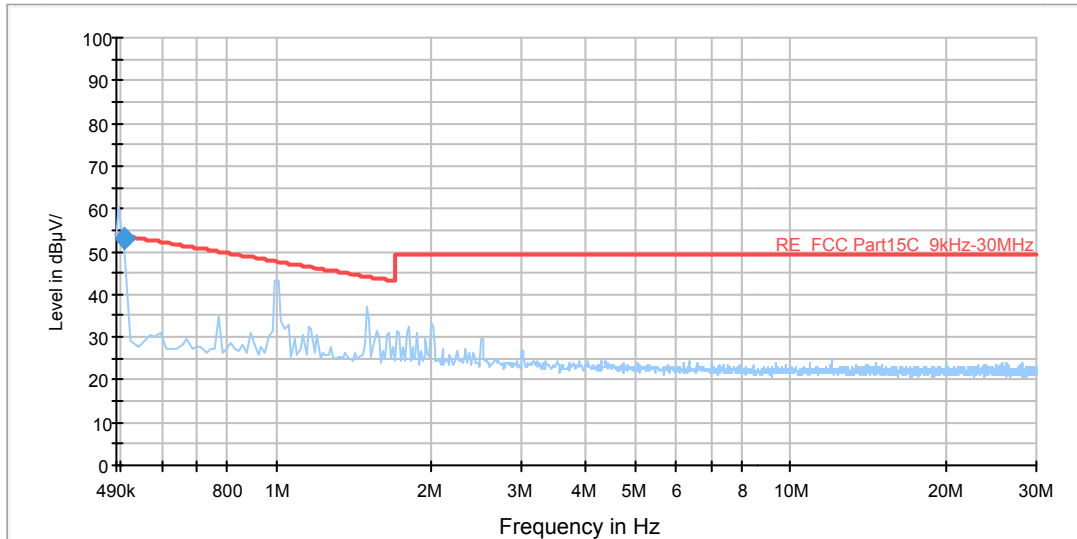

Radiated Emission 490K-30MHz

Frequency (MHz)	Quasi-Peak (dBuV/m)	Reading value (dBuV/m)	Azimuth (deg)	Correct Factor(dB)	Margin (dB)	Limit (dBuV/m)
0.506000	53.3	73.0	0.0	19.7	0.4	53.7

RE 0.03-1GHz QP Class B

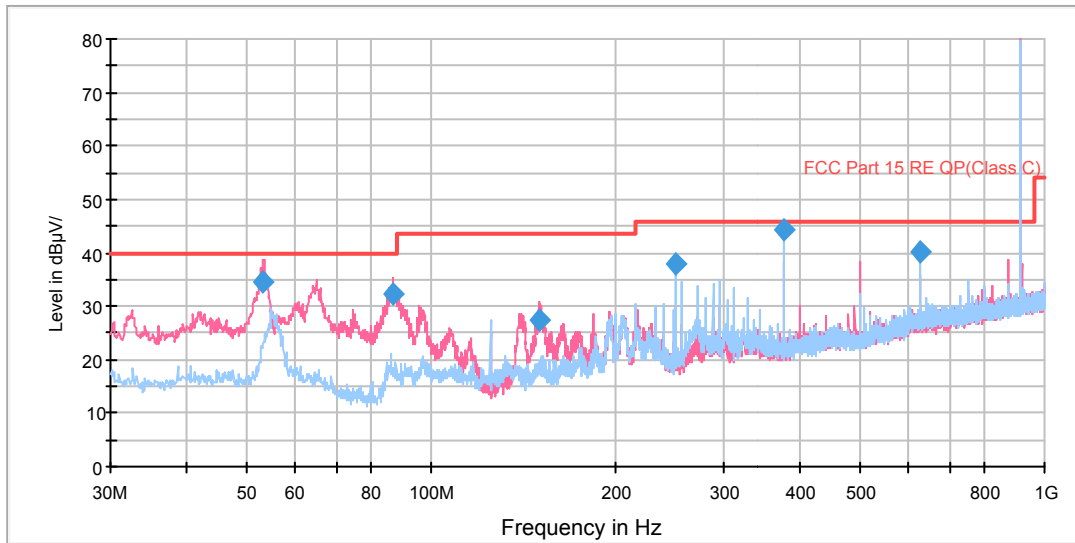

Note: The signal beyond the limit is carrier.

Radiated Emission 30M-1GHz

Frequency (MHz)	Quasi-Peak (dBuV/m)	Reading value (dBuV/m)	Height (cm)	Polarization	Azimuth (deg)	Correct Factor (dB)	Margin (dB)	Limit (dBuV/m)
53.240000	34.4	47.2	100.0	V	334.0	12.8	5.6	40.0
86.903750	32.3	43.1	125.0	V	287.0	10.8	7.7	40.0
150.281250	27.6	36.7	100.0	V	225.0	9.1	15.9	43.5
249.987500	38.1	52.2	100.0	H	22.0	14.1	7.9	46.0
374.996250	44.4	61.8	100.0	H	33.0	17.4	1.6	46.0
625.015000	40.0	62.2	114.0	H	0.0	22.2	6.0	46.0

- Remark: 1. Quasi-Peak = Reading value + Correction factor
 2. Correction Factor = Antenna factor+ Insertion loss(cable loss+amplifier gain)
 3. Margin = Limit – Quasi-Peak

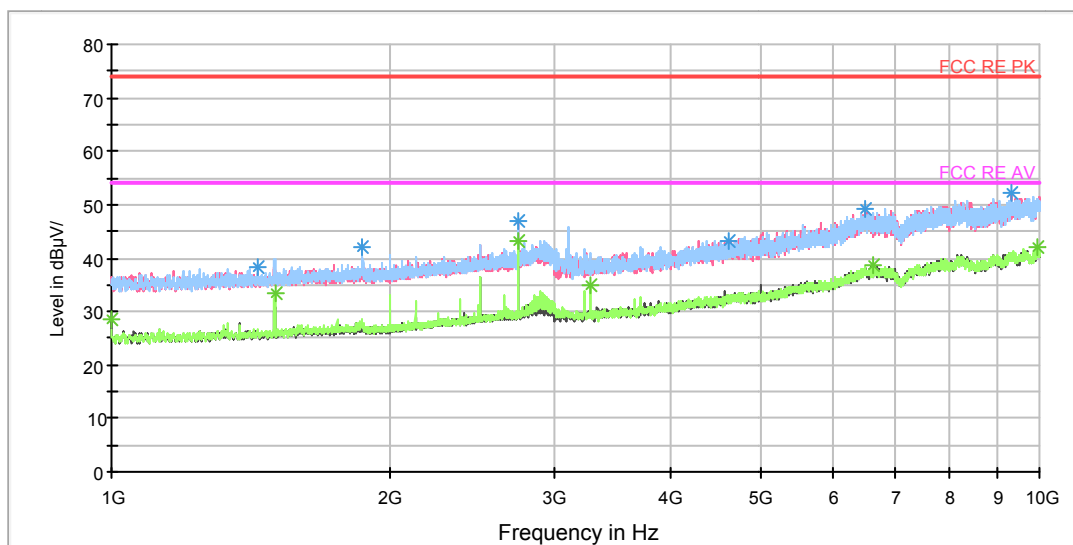

Radiated Emission 1G-10GHz

Frequency (MHz)	Peak (dBuV/m)	Reading value (dBuV/m)	Height (cm)	Polarization	Azimuth (deg)	Correct Factor (dB)	Margin (dB)	Limit (dBuV/m)
1436.000000	38.3	48.0	100.0	H	2.0	-9.7	31.7	70
1866.000000	42.0	50.2	100.0	H	23.0	-8.2	28.0	70
2748.000000	47.0	51.3	100.0	V	214.0	-4.3	23.0	70
4632.750000	43.4	44.2	100.0	V	0.0	-0.8	26.6	70
6494.750000	49.1	54.5	100.0	V	0.0	5.4	20.9	70
9314.000000	52.2	62.2	100.0	V	0.0	10.0	17.8	70

Frequency (MHz)	Average (dBuV/m)	Reading value (dBuV/m)	Height (cm)	Polarization	Azimuth (deg)	Correct Factor (dB)	Margin (dB)	Limit (dBuV/m)
1000.000000	28.7	40.1	100.0	V	4.0	-11.4	21.3	50
1500.000000	33.3	42.8	100.0	H	23.0	-9.5	16.7	50
2748.000000	43.2	47.5	100.0	H	92.0	-4.3	6.8	50
3283.500000	35.1	38.3	100.0	H	0.0	-3.2	14.9	50
6613.750000	38.7	43.8	100.0	V	0.0	5.1	11.3	50
9951.000000	42.2	53.7	100.0	V	0.0	11.5	7.8	50

3.4 Conducted Emissions

Ambient condition

Temperature	Relative humidity	Pressure
23°C ~25°C	45%~50%	101.5kPa

Method of Measurement

The EUT is placed on a non-metallic table of 80cm height above the horizontal metal reference ground plane. During the test, the EUT was operating in its typical mode. The test method is according to ANSI C63.10-2013. Connect the AC power line of the EUT to the L.I.S.N. Use EMI receiver to detect the average and Quasi-peak value. RBW is set to 9 kHz, VBW is set to 30kHz. The measurement result should include both L line and N line.

The test is in transmitting mode.

Test Setup

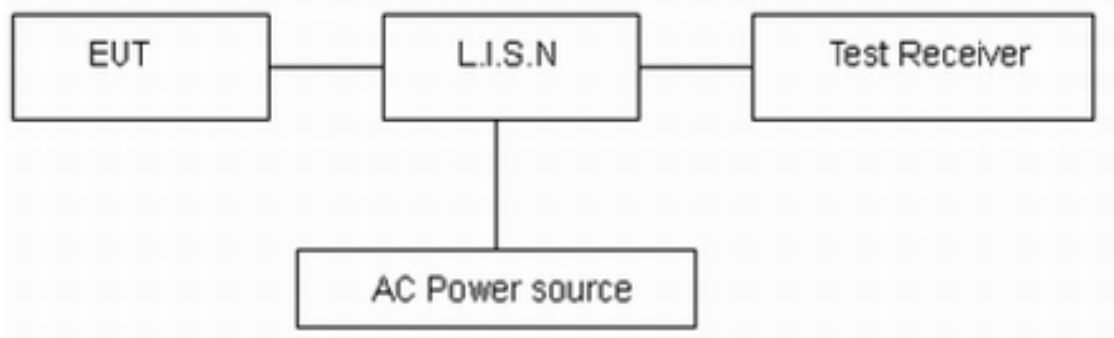

Note: AC Power source is used to change the voltage from 220V/50Hz to 110V/60Hz.

Limits

Frequency (MHz)	Conducted Limits(dBμV)	
	Quasi-peak	Average
0.15 - 0.5	66 to 56 *	56 to 46 *
0.5 - 5	56	46
5 - 30	60	50

*: Decreases with the logarithm of the frequency.

Measurement Uncertainty

The assessed measurement uncertainty to ensure 95% confidence level for the normal distribution is with the coverage factor $k = 2$. $U = 1.19$ dB

Test Results:

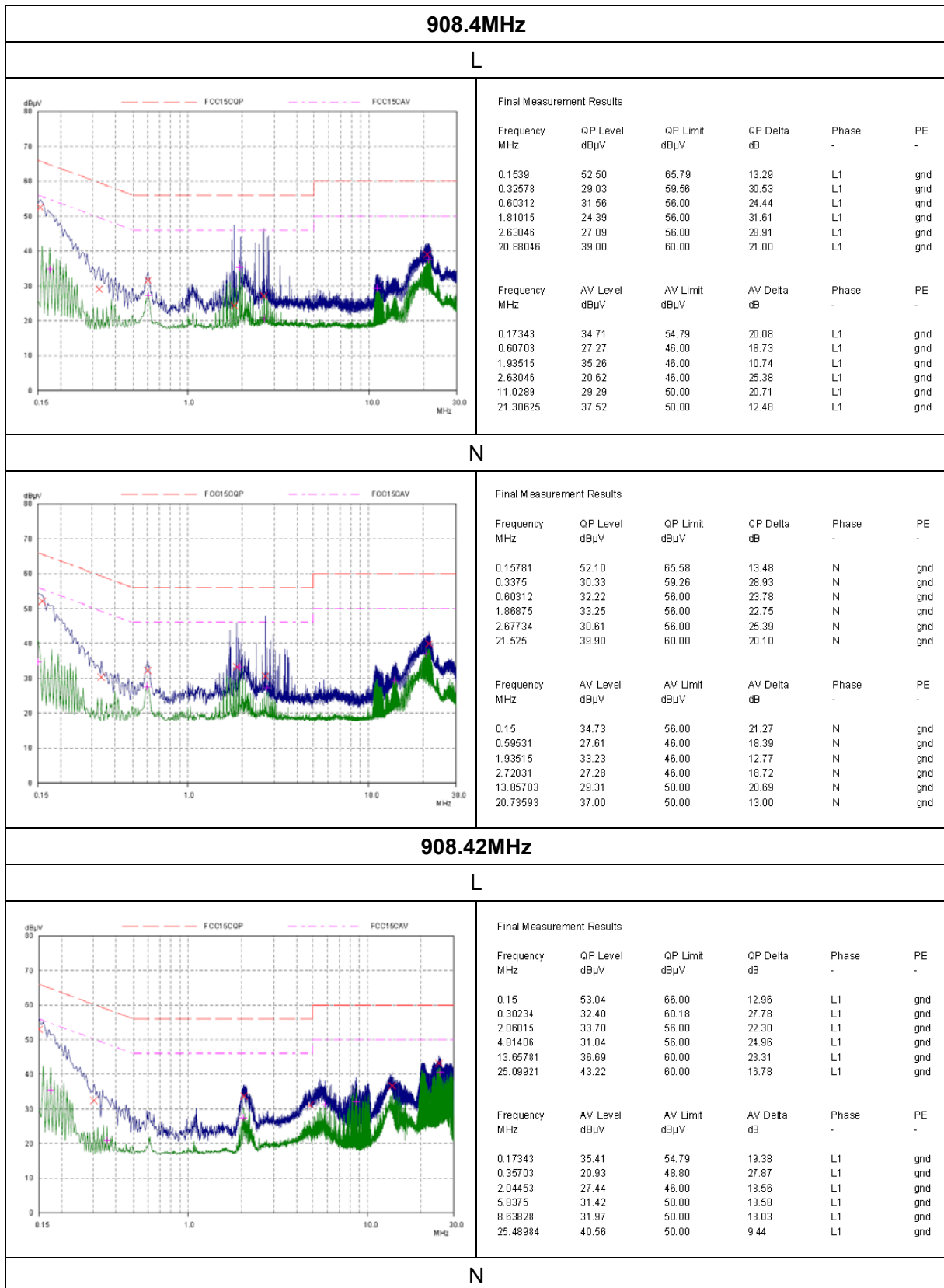

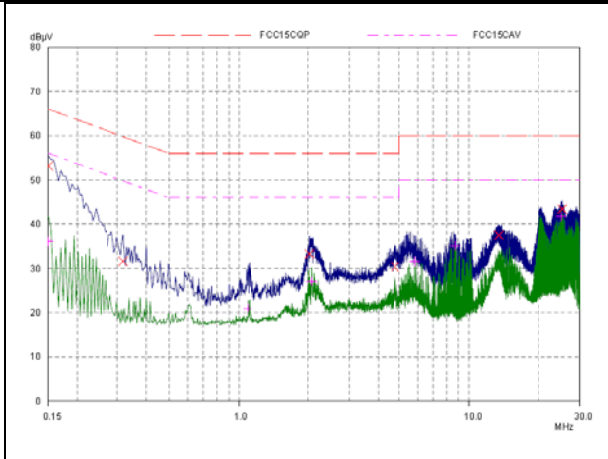

Final Measurement Results

Frequency MHz	QP Level dBµV	QP Limit dBµV	QP Delta dB	Phase	PE
0.15	53.16	66.00	12.84	N	gnd
0.31796	31.61	59.76	28.15	N	gnd
2.0289	33.23	56.00	22.77	N	gnd
4.74765	30.40	56.00	25.60	N	gnd
13.42734	37.48	60.00	22.52	N	gnd
25.3414	43.43	60.00	16.57	N	gnd

Frequency MHz	AV Level dBµV	AV Limit dBµV	AV Delta dB	Phase	PE
0.15	36.08	56.00	19.92	N	gnd
1.0914	21.00	46.00	25.00	N	gnd
2.07187	26.99	46.00	19.01	N	gnd
5.8375	31.49	50.00	18.51	N	gnd
8.72031	35.15	50.00	14.85	N	gnd
25.10703	41.74	50.00	8.26	N	gnd

916MHz

L

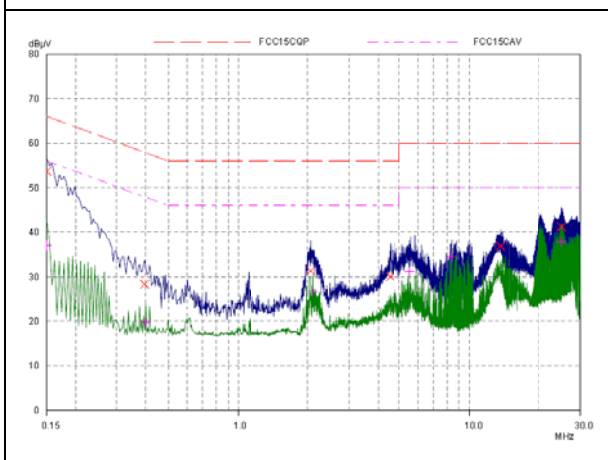

Final Measurement Results

Frequency MHz	QP Level dBµV	QP Limit dBµV	QP Delta dB	Phase	PE
0.15	53.66	66.00	12.34	L1	gnd
0.39609	28.32	57.93	29.61	L1	gnd
2.06406	31.32	56.00	24.68	L1	gnd
4.50546	30.03	56.00	25.97	L1	gnd
13.57968	36.90	60.00	23.10	L1	gnd
25.09531	41.22	60.00	18.78	L1	gnd

Frequency MHz	AV Level dBµV	AV Limit dBµV	AV Delta dB	Phase	PE
0.15	37.03	56.00	18.97	L1	gnd
0.4	19.72	47.85	28.13	L1	gnd
2.10312	26.81	46.00	19.19	L1	gnd
5.525	31.12	50.00	18.88	L1	gnd
8.32578	34.36	50.00	15.64	L1	gnd
25.09531	37.88	50.00	12.12	L1	gnd

N

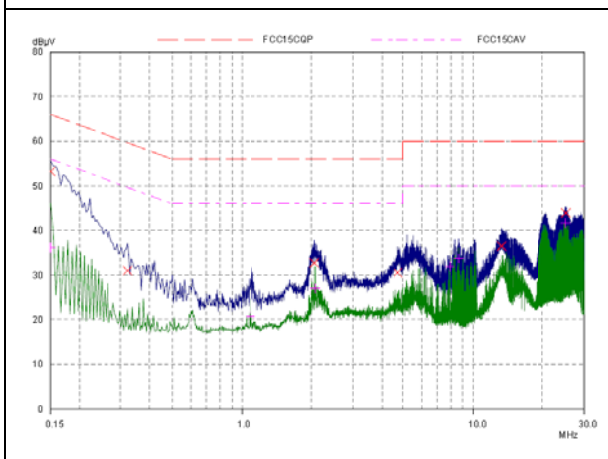

Final Measurement Results

Frequency MHz	QP Level dBµV	QP Limit dBµV	QP Delta dB	Phase	PE
0.15	53.22	66.00	12.78	N	gnd
0.32187	31.01	59.66	28.65	N	gnd
2.05625	32.72	56.00	23.28	N	gnd
4.73593	30.54	56.00	25.46	N	gnd
13.19296	36.49	60.00	23.51	N	gnd
25.18125	43.89	60.00	16.11	N	gnd

Frequency MHz	AV Level dBµV	AV Limit dBµV	AV Delta dB	Phase	PE
0.15	36.16	56.00	19.84	N	gnd
1.0914	20.77	46.00	25.23	N	gnd
2.07187	26.99	46.00	19.01	N	gnd
7.93906	31.88	50.00	18.12	N	gnd
8.63828	33.68	50.00	16.32	N	gnd
25.10312	41.64	50.00	8.36	N	gnd

4 Main Test Instruments

Name	Type	Manufacturer	Serial Number	Calibration Date	Expiration Time
EMI Test Receiver	ESCS30	R&S	100138	2014-12-17	2015-12-16
EMI Test Receiver	ESCI	R&S	100948	2015-05-25	2016-05-24
Loop Antenna	FMZB1519	SCHWARZBEC K	1519-047	2014-02-29	2017-02-28
Spectrum Analyzer	FSV30	R&S	100815	2014-12-17	2015-12-16
Spectrum Analyzer	N9010A	Agilent	MY47191109	2015-05-22	2016-05-21
Horn Antenna	HF907	R&S	100126	2015-07-01	2018-06-30
BT Base Station Simulator	CBT	R&S	100271	2015-05-25	2016-05-24
Loop Antenna	FMZB1519	SCHWARZBEC K	1519-047	2014-02-29	2017-02-28
EMI Test Receiver	ESCS30	R&S	100138	2014-12-17	2015-12-16
LISN	ENV216	R&S	101171	2014-12-17	2015-12-16
EMI Test Receiver	ESCI	R&S	100948	2015-05-25	2016-05-24
TRILOG Broadband Antenna	VULB 9163	Schwarzbeck	9163-201	2013-11-25	2016-11-24
Double Ridged Waveguide Horn Antenna	HF907	R&S	100126	2015-07-01	2018-06-30
Power Splitter	SHX-GF2-2-13	Hua Xiang	10120101	NA	NA
Spectrum Analyzer	FSV30	R&S	100815	2014-12-17	2015-12-16
Spectrum Analyzer	N9010A	Agilent	MY47191109	2015-05-22	2016-05-21
Standard Gain Horn	3160-09	ETS-Lindgren	00102644	2015-05-19	2018-05-18
RF Cable	SMA 15cm	Agilent	0001	2015-11-09	2016-01-08

*****END OF REPORT *****

A.2 Test Setup



Below 1GHz

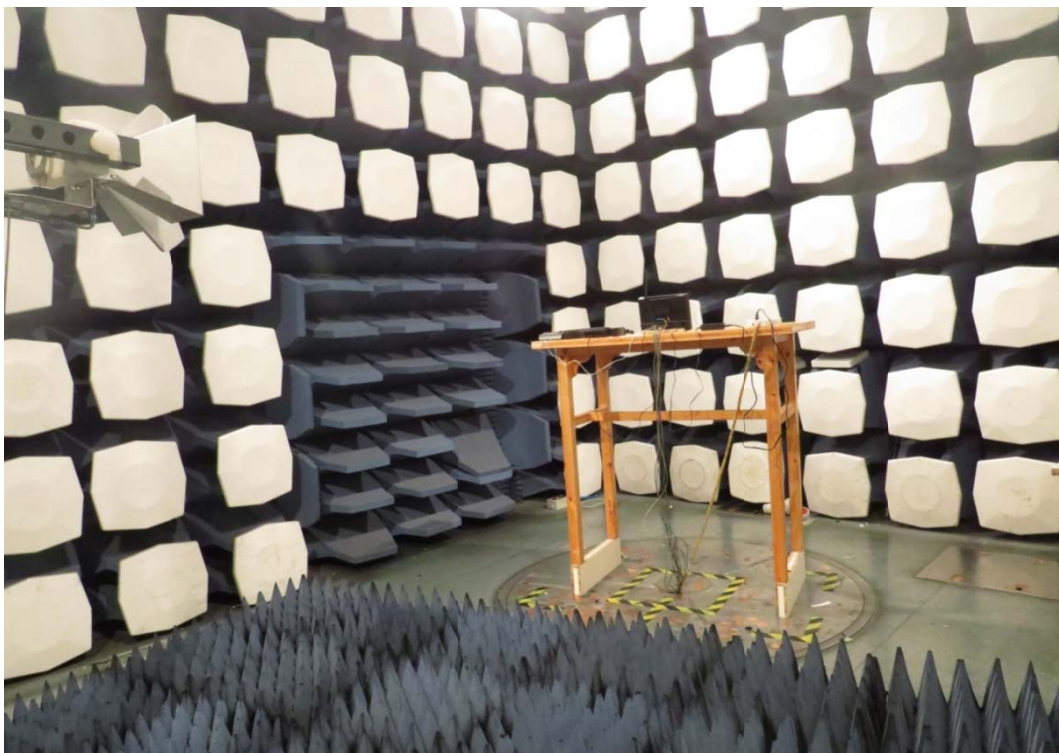

Above 1GHz

Picture 2 Radiated Emission Test Setup



Picture 3 Conducted Emission Test Setup