



# RF TEST REPORT

**Applicant** Nokia ShangHai Bell Co., Ltd  
**FCC ID** 2ADZRG240WG  
**Product** 7368 ISAM ONT  
**Brand** NOKIA  
**Marketing** G-240W-G  
**Model** G-240W-G  
**Report No.** R1807B0070-R1V1  
**Issue Date** October 19, 2018

TA Technology (Shanghai) Co., Ltd. tested the above equipment in accordance with the requirements in **FCC CFR47 Part 15C (2018)**. The test results show that the equipment tested is capable of demonstrating compliance with the requirements as documented in this report.

*Performed by: Peng Tao*

*Approved by: Kai Xu*

---

## TA Technology (Shanghai) Co., Ltd.

No.145, Jintang Rd, Tangzhen Industry Park, Pudong Shanghai, China

TEL: +86-021-50791141/2/3

FAX: +86-021-50791141/2/3-8000



## TABLE OF CONTENT

1. Test Laboratory .....	4
1.1. Notes of the test report.....	4
1.2. Test facility .....	4
1.3. Testing Location.....	5
2. General Description of Equipment under Test.....	6
3. Applied Standards .....	8
4. Test Configuration .....	9
5. Test Case Results .....	10
5.1. Maximum conducted output power .....	10
5.2. 6dB Bandwidth .....	14
5.3. Band Edge .....	18
5.4. Power Spectral Density .....	21
5.5. Spurious RF Conducted Emissions.....	28
5.6. Unwanted Emission .....	32
5.7. Conducted Emission .....	66
6. Main Test Instruments.....	68
ANNEX A: EUT Appearance and Test Setup.....	69
A.1 EUT Appearance .....	69
A.2 Test Setup .....	73



## Summary of measurement results

Number	Summary of measurements of results	Clause in FCC rules	Verdict
1	Maximum conducted output power	15.247(b)(3)	PASS
2	6 dB bandwidth	15.247(a)(2)	PASS
3	Power spectral density	15.247(e)	PASS
4	Band Edge	15.247(d)	PASS
5	Spurious RF Conducted Emissions	15.247(d)	PASS
6	Unwanted Emissions	15.247(d),15.205,15.209	PASS
7	Conducted Emissions	15.207	PASS

Date of Testing: July 9, 2018~ August 24, 2018

## 1. Test Laboratory

### 1.1. Notes of the test report

This report shall not be reproduced in full or partial, without the written approval of **TA technology (shanghai) co., Ltd.** The results documented in this report apply only to the tested sample, under the conditions and modes of operation as described herein .Measurement Uncertainties were not taken into account and are published for informational purposes only. This report is written to support regulatory compliance of the applicable standards stated above.

### 1.2. Test facility

#### **CNAS (accreditation number: L2264)**

TA Technology (Shanghai) Co., Ltd. has obtained the accreditation of China National Accreditation Service for Conformity Assessment (CNAS).

#### **FCC (Designation number: CN1179, Test Firm Registration Number: 446626)**

TA Technology (Shanghai) Co., Ltd. has been listed on the US Federal Communications Commission list of test facilities recognized to perform electromagnetic emissions measurements.

#### **IC (recognition number is 8510A)**

TA Technology (Shanghai) Co., Ltd. has been listed by industry Canada to perform electromagnetic emission measurement.

#### **VCCI (recognition number is C-4595, T-2154, R-4113, G-10766)**

TA Technology (Shanghai) Co., Ltd. has been listed by industry Japan to perform electromagnetic emission measurement.

#### **A2LA (Certificate Number: 3857.01)**

TA Technology (Shanghai) Co., Ltd. has been listed by American Association for Laboratory Accreditation to perform electromagnetic emission measurement.



### 1.3. Testing Location

Company: TA Technology (Shanghai) Co., Ltd.  
Address: No.145, Jintang Rd, Tangzhen Industry Park, Pudong  
City: Shanghai  
Post code: 201201  
Country: P. R. China  
Contact: Xu Kai  
Telephone: +86-021-50791141/2/3  
Fax: +86-021-50791141/2/3-8000  
Website: <http://www.ta-shanghai.com>  
E-mail: [xukai@ta-shanghai.com](mailto:xukai@ta-shanghai.com)

## 2. General Description of Equipment under Test

### Client Information

Applicant	Nokia ShangHai Bell Co., Ltd.
Applicant address	No. 388, Ningqiao Rd. Pilot Free Trade Zone, Shanghai, China
Manufacturer	Nokia Shanghai Bell CO., Ltd.
Manufacturer address	No. 388, Ningqiao Rd. Pilot Free Trade Zone, Shanghai, China

### General information

EUT Description	
Model	G-240W-G
IMEI	/
Hardware Version	PEM2
Software Version	Null
Power Supply	AC adapter
Antenna Type	Internal Antenna
Antenna Connector	A permanently attached antenna (meet with the standard FCC Part 15.203 requirement)
Antenna Gain	Antenna 1: 3.00 dBi Antenna 2: 3.00 dBi
additional beamforming gain	NA
Test Mode	802.11b 802.11g, 802.11n(HT20/HT40);
Modulation Type	802.11b: DSSS; 802.11g/n(HT20/HT40): OFDM
Max. Conducted Power	Wi-Fi 2.4G :24.32dBm
Operating Frequency Range(s)	802.11b/g/n(HT20): 2412 ~ 2462 MHz 802.11n(HT40): 2422 ~ 2452 MHz
EUT Accessory	
Adapter 1	Manufacturer: MOSO POWER SUPPLY TECHNOLOGY CO.,LTD Model: MSA-C3000CS12.0-40W-US
Adapter 2	Manufacturer: SHENZHEN RUIDE ELECTRONICAL INDUSTRIAL CO.,LTD Model: RD1203000-C55-20MG
Adapter 3	Manufacturer: MOSO POWER SUPPLY TECHNOLOGY CO.,LTD Model: MSA-C3000CS12.0-40W-DE



Adapter 4	Manufacturer: SHENZHEN RUIDE ELECTRONICAL INDUSTRIAL CO.,LTD Model: RD1203000-C55-20OG
Adapter 5	Manufacturer: LUCENT TRANS ELECTRONICS CO., LTD Model: 1L43-US1230
Adapter 6	Manufacturer: Shenzhen Mass Power Electronic Limited Model: NBS40C120300M2
Adapter 7	Manufacturer: ShenZhen SOY Technology Co., Ltd. Model: SOY-1200300
Note: The information of the EUT is declared by the manufacturer. 2. There is more than one Adapter, each one should be applied throughout the compliance test respectively, and however, only the worst case (Adapter 1) will be recorded in this report.	

**Information of Configuration:**

No.	Name	Model/Code No.	Edition	Serial No. or Quantity
1.1	G-240W-G	3FE47555BB	PEM2	PEM
1.2	G-240W-G	3FE47555AB	PEM2	PEM
1.3	G-240W-G	3FE47555AE	PEM2	PEM
2.1	Power adapter	RD1203000-C55-20MG	A/0	PEM
2.2	Power adapter	MSA-C3000CS12.0-40W-US	A/0	PEM
2.3	Power adapter	1L43-US1230	A/0	PEM
2.4	Power adapter	MSA-C3000CS12.0-40W-DE	A/0	PEM
2.5	Power adapter	RD1203000-C55-20OG	A/0	PEM
2.6	Power adapter	NBS40C120300M2	A/0	PEM
2.7	Power adapter	SOY-1200300	A/0	PEM

Kit Code	EMA	Part Description	Power Adaptor
3FE47536DA	3FE 47555 BB	2POTS,4GE,WIFI 802.11ac 3x3/802.11n 2x2, Emcore BOSA,AR Plug, 2PIN	NBS40C120300M2/ SOY-1200300
3FE47536BA	3FE 47555 AB	2POTS,4GE,WIFI 802.11ac 3x3/802.11n 2x2, Emcore BOSA,EU Plug Type C, 2PIN	RD1203000-C55-20OG/ MSA-C3000CS12.0-40W-DE
3FE47536BB	3FE 47555 BB	2POTS,4GE,WIFI 802.11ac 3x3/802.11n 2x2, Emcore BOSA,EU Plug Type C, 2PIN	RD1203000-C55-20OG/ MSA-C3000CS12.0-40W-DE
3FE47536AE	3FE 47555 AE	2POTS,4GE,WIFI 802.11ac 3x3/802.11n 2x2, Emcore BOSA,US Plug, 2PIN	RD1203000-C55-20MG/ MSAC3000CS12.0-40W-US/ 1L43-US1230

### 3. Applied Standards

According to the specifications of the manufacturer, it must comply with the requirements of the following standards:

#### Test standards

- **FCC CFR47 Part 15C (2018) Radio Frequency Devices**
- **ANSI C63.10 (2013)**
- **KDB 558074 D01 DTS Meas Guidance v04**
- **KDB 662911 D01 Multiple Transmitter Output v02r01**



## 4. Test Configuration

### Test Mode

The EUT has been associated with peripherals and configuration operated in a manner tended to maximize its emission characteristics in a typical application.

The radiated emission was measured in the following position: EUT stand-up position (Z axis), lie-down position (X, Y axis). The worst emission was found in stand-up position (Z axis) and the worst case was recorded.

In order to find the worst case condition, Pre-tests are needed at the presence of different data rate. Preliminary tests have been done on all the configuration for confirming worst case. Data rate below means worst-case rate of each test item.

### The test software is used accessMtool

Worst-case data rates are shown as following table.

Band	Data Rate		
	Antenna 1	Antenna 2	MIMO
802.11b	1 Mbps	/	/
802.11g	6 Mbps	6 Mbps	/
802.11n HT20	/	/	MCS0
802.11n HT40	/	/	MCS0

The worst case Antenna mode for each of the following tests for Wi-Fi:

Test Cases	Antenna 1	Antenna 2	MIMO
Maximum conducted output power	802.11b/g	802.11g	802.11n HT20 802.11n HT40
6dB Bandwidth	802.11b	802.11g	802.11n HT20 802.11n HT40
Band Edge	--	O	--
Power Spectral Density	802.11b/g	802.11g	802.11n HT20 802.11n HT40
Spurious RF Conducted Emissions	--	O	--
Unwanted Emissions	802.11b	802.11g	802.11n HT20 802.11n HT40
Conducted Emission	802.11b	802.11g	802.11n HT20 802.11n HT40
Note: "O": test all bands			

According to RF Output power results in chapter 5.1, MIMO antenna 2 was selected as the worst MIMO antenna for 802.11n HT20/ HT40. SISO Antenna 1 was selected as the worst SISO antenna for 802.11b. SISO Antenna 2 was selected as the worst SISO antenna for 802.11g.

## 5. Test Case Results

### 5.1. Maximum conducted output power

#### Ambient condition

Temperature	Relative humidity	Pressure
23°C ~25°C	45%~50%	101.5kPa

#### Methods of Measurement

During the process of the testing, The EUT was connected to Average Power meter with a known loss. The EUT is max power transmission with proper modulation. The signal transmission is continuous.

The conducted Power is measured at each antenna port. The measured results at the various antenna ports are then summed mathematically.

#### Test Setup

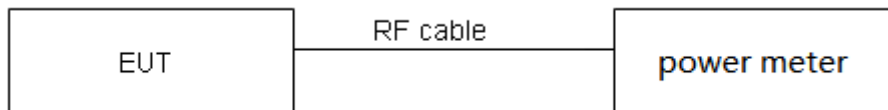

#### Limits

Rule Part 15.247 (b) (3) specifies that " For systems using digital modulation in the 902–928 MHz, 2400–2483.5 MHz: 1 Watt."

Average Output Power	$\leq 1W$ (30dBm)
----------------------	-------------------

#### Measurement Uncertainty

The assessed measurement uncertainty to ensure 95% confidence level for the normal distribution is with the coverage factor  $k = 2$ ,  $U = 0.44$  dB.

**Test Results**

Band	T <sub>on</sub> (ms)	T <sub>(on+off)</sub> (ms)	Duty cycle	Duty cycle correction Factor(dB)
802.11b	12.40	13.04	0.95	0.22
802.11g	2.18	2.29	0.95	0.22
802.11n HT20	1.91	2.02	0.95	0.23
802.11n HT40	1.06	1.16	0.91	0.39
Note: when Duty cycle>0.98, Duty cycle correction Factor not required.				

**SISO Antenna 1**

Network Standards	Carrier frequency (MHz)	Average Power Measured (dBm)	Average Power with duty factor (dBm)	Limit (dBm)	Conclusion
802.11b	2412	22.63	22.85	30	PASS
	2437	22.89	23.11	30	PASS
	2462	23.24	23.46	30	PASS
802.11g	2412	20.74	20.96	30	PASS
	2437	20.88	21.10	30	PASS
	2462	21.22	21.44	30	PASS

Note: Average Power with duty factor = Average Power Measured +Duty cycle correction factor

**SISO Antenna 2**

Network Standards	Carrier frequency (MHz)	Average Power Measured (dBm)	Average Power with duty factor (dBm)	Limit (dBm)	Conclusion
802.11g	2412	20.87	21.09	30	PASS
	2437	21.06	21.28	30	PASS
	2462	21.46	21.68	30	PASS

Note: Average Power with duty factor = Average Power Measured +Duty cycle correction factor

**MIMO**

Network Standards	Carrier frequency (MHz)	MIMO Antenna 1		MIMO Antenna 2		Total Power (dBm)	Limit (dBm)	Conclusion
		Average Power Measured (dBm)	Average Power with duty factor (dBm)	Average Power Measured (dBm)	Average Power with duty factor (dBm)			
802.11n HT20	2412	20.55	20.78	20.96	21.19	24.00	30	PASS
	2437	20.76	20.99	21.15	21.38	24.20	30	PASS
	2462	20.94	21.17	21.22	21.45	24.32	30	PASS
802.11n HT40	2422	19.64	20.03	20.06	20.45	23.26	30	PASS
	2437	19.44	19.83	20.37	20.76	23.33	30	PASS
	2452	19.35	19.74	20.55	20.94	23.39	30	PASS

Note: 1. Average Power with duty factor = Average Power Measured + Duty cycle correction factor  
 2. For Total Power, according to KDB 662911 D01 Multiple Transmitter Output v02r01 1),  
 The Total Power =  $10\log(10^{(Power\ antenna1\ in\ dBm/10)} + 10^{(Power\ antenna2\ in\ dBm/10)})$ .  
 3. The manufacturer declared the transmitter output signals is CDD mode. And  $N_{SS}=1$ . According to KDB 662911 D01 Multiple Transmitter Output v02r01 2)f)(i): If all antennas have the same gain, Directional gain =  $G_{ANT} + \text{Array Gain}$ ,  
 For power measurements on IEEE 802.11 devices,  
 Array Gain = 0 dB (i.e., no array gain) for  $N_{ANT} \leq 4$ ;  
 Array Gain = 0 dB (i.e., no array gain) for channel widths  $\geq 40$  MHz for any  $N_{ANT}$ ;  
 Array Gain =  $5 \log(N_{ANT}/N_{SS})$  dB or 3 dB, whichever is less, for 20-MHz channel widths with  $N_{ANT} \geq 5$ .  
 So directional gain =  $G_{ANT} + \text{Array Gain} = 3 + 0 = 3$  dBi  $< 6$  dBi. So the power limit is 30 dBm

## 5.2. 6dB Bandwidth

### Ambient condition

Temperature	Relative humidity	Pressure
23°C ~25°C	45%~50%	101.5kPa

### Method of Measurement

The EUT was connected to the spectrum analyzer through an external attenuator (20dB) and a known loss cable. RBW is set to 100 kHz; VBW is set to 300 kHz on spectrum analyzer. Dector=Peak, Trace mode=max hold.

### Test Setup

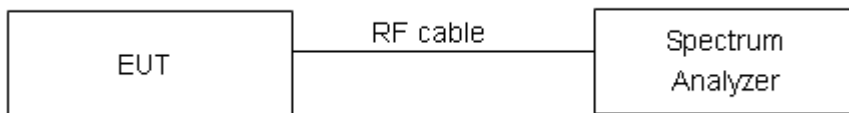

### Limits

Rule Part 15.247 (a) (2) specifies that “Systems using digital modulation techniques may operate in the 902–928 MHz, 2400–2483.5 MHz bands. The minimum 6 dB bandwidth shall be at least 500 kHz.”

minimum 6 dB bandwidth	≥ 500 kHz
------------------------	-----------

### Measurement Uncertainty

The assessed measurement uncertainty to ensure 95% confidence level for the normal distribution is with the coverage factor  $k = 2$ ,  $U = 936$  Hz.

**Test Results:**

**SISO Antenna 1**

Network Standards	Carrier frequency (MHz)	99% bandwidth (MHz)	Minimum 6 dB bandwidth (MHz)	Limit (kHz)	Conclusion
802.11b	2412	10.099	8.095	500	PASS
	2437	10.076	8.080	500	PASS
	2462	10.084	8.088	500	PASS

**SISO Antenna 2**

Network Standards	Carrier frequency (MHz)	99% bandwidth (MHz)	Minimum 6 dB bandwidth (MHz)	Limit (kHz)	Conclusion
802.11g	2412	16.535	16.380	500	PASS
	2437	16.421	15.450	500	PASS
	2462	16.562	16.380	500	PASS

**MIMO Antenna 2**

Network Standards	Carrier frequency (MHz)	99% bandwidth (MHz)	Minimum 6 dB bandwidth (MHz)	Limit (kHz)	Conclusion
802.11n HT20	2412	17.571	15.460	500	PASS
	2437	17.565	15.130	500	PASS
	2462	17.653	17.600	500	PASS
802.11n HT40	2422	35.640	18.700	500	PASS
	2437	35.952	35.400	500	PASS
	2452	35.952	35.660	500	PASS



SISO Antenna 1

802.11b, Carrier frequency (MHz): 2412



SISO Antenna 2

802.11g, Carrier frequency (MHz): 2412



802.11b, Carrier frequency (MHz): 2437



802.11g, Carrier frequency (MHz): 2437



802.11b, Carrier frequency (MHz): 2462

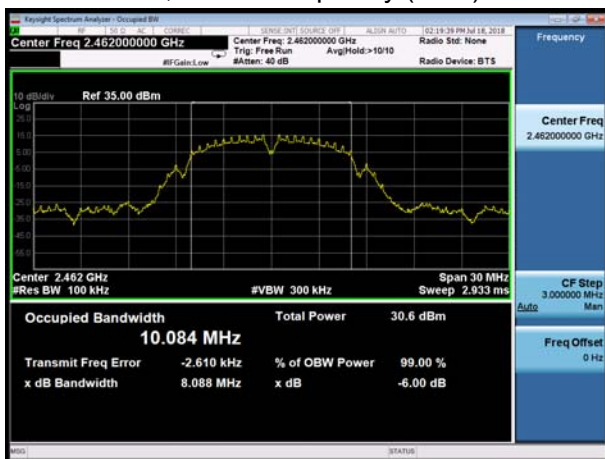

802.11g, Carrier frequency (MHz): 2462

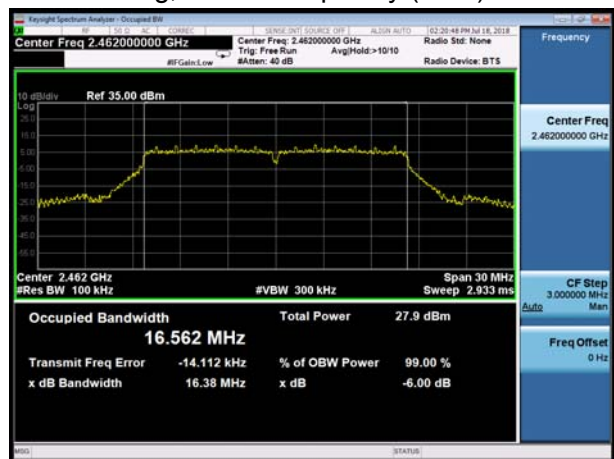



MIMO Antenna 2

802.11n(HT20), Carrier frequency (MHz): 2412

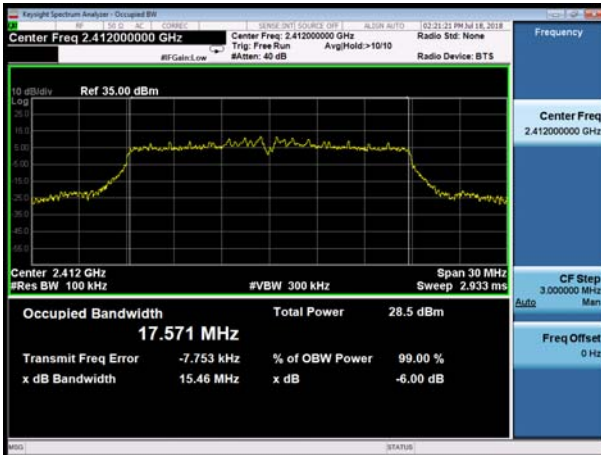

802.11n(HT40), Carrier frequency (MHz): 2422

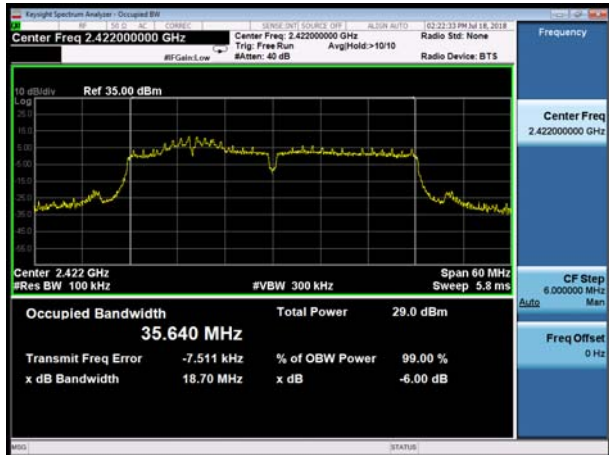

802.11n(HT20), Carrier frequency (MHz): 2437

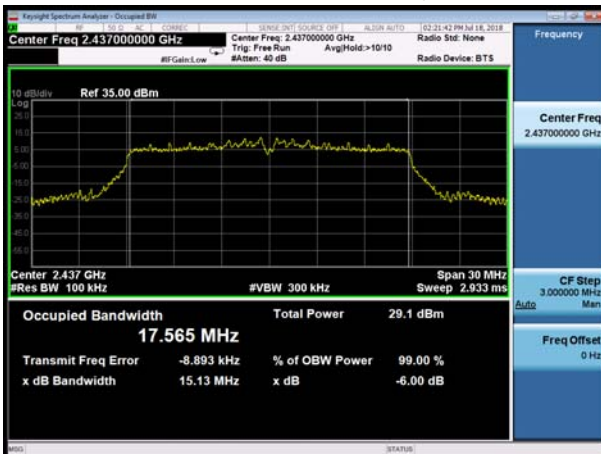

802.11n(HT40), Carrier frequency (MHz): 2437

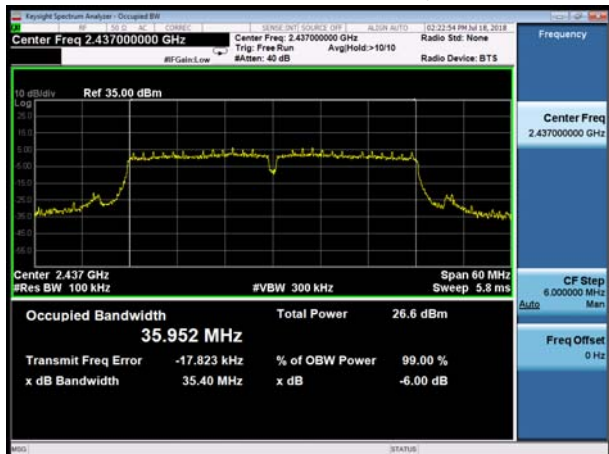

802.11n(HT20), Carrier frequency (MHz):2462

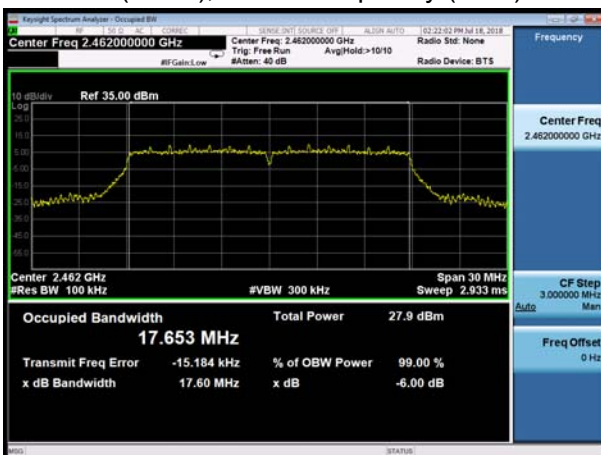

802.11n(HT40), Carrier frequency (MHz):2452

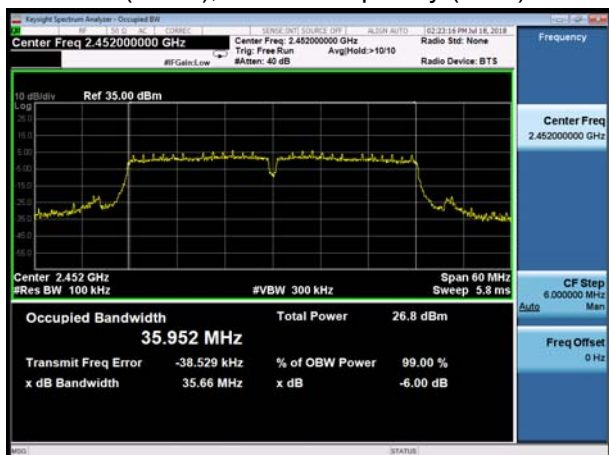

### 5.3. Band Edge

#### Ambient condition

Temperature	Relative humidity	Pressure
23°C ~25°C	45%~50%	101.5kPa

#### Method of Measurement

The EUT was connected to the spectrum analyzer through an external attenuator (20dB) and a known loss cable the band edge of the lowest and highest channels were measured. The peak detector is used and RBW is set to 100 kHz and VBW is set to 300 kHz on spectrum analyzer. Spectrum analyzer plots are included on the following pages.

#### Test Setup

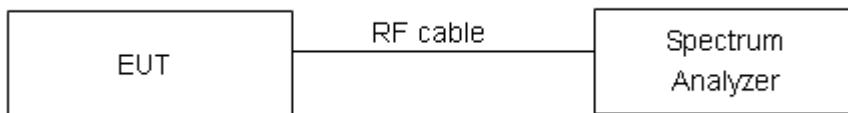

#### Limits

Rule Part 15.247(d) specifies that “In any 100 kHz bandwidth outside the frequency band in which the spread spectrum or digitally modulated intentional radiator is operating, the radio frequency power that is produced by the intentional radiator shall be at least 20 dB below that in the 100 kHz bandwidth within the band that contains the highest level of the desired power, based on either an RF conducted or a radiated measurement, provided the transmitter demonstrates compliance with the peak conducted power limits.” If the transmitter complies with the conducted power limits based on the use of RMS averaging over a time interval, as permitted under paragraph (b)(3) of this section, the attenuation required under this paragraph shall be 30 dB instead of 20 dB.”

#### Measurement Uncertainty

The assessed measurement uncertainty to ensure 95% confidence level for the normal distribution is with the coverage factor  $k = 1.96$ .

Frequency	Uncertainty
2GHz-3GHz	1.407 dB



Test Results: PASS

SISO Antenna 1

802.11b, Channel No.: 1

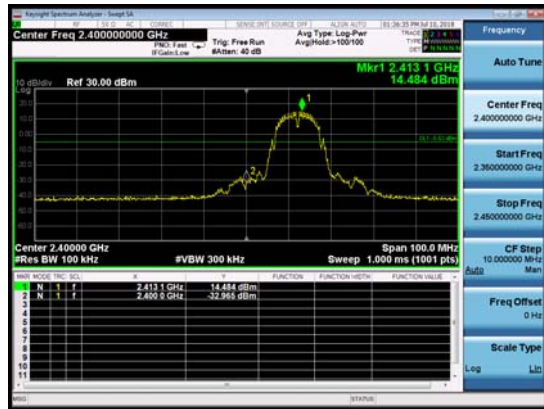

802.11b, Channel No.: 11

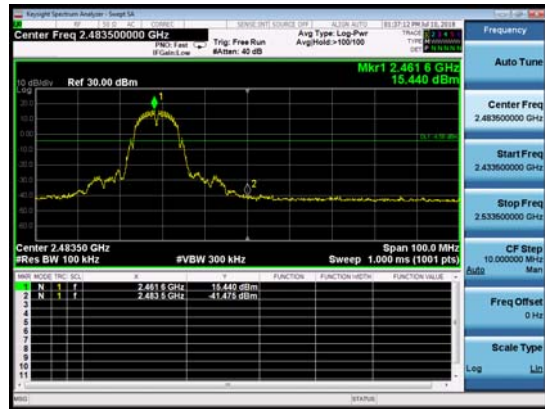

SISO Antenna 2

802.11g, Channel No.: 1

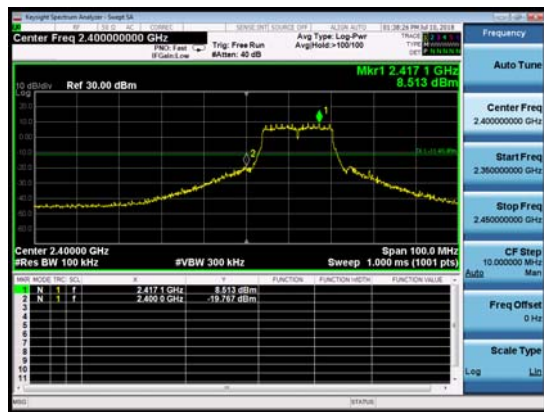

802.11g, Channel No.: 11



MIMO Antenna 2

802.11n(HT20), Channel No.: 1

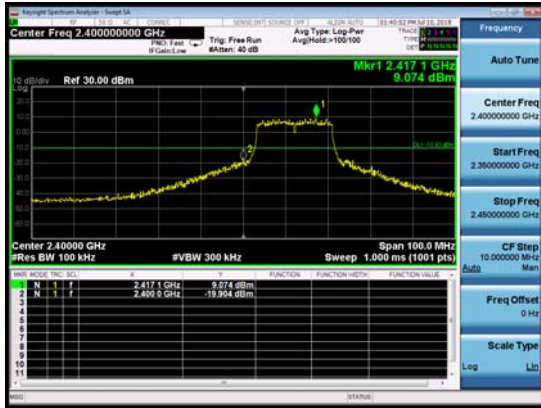

802.11n(HT20), Channel No.: 11

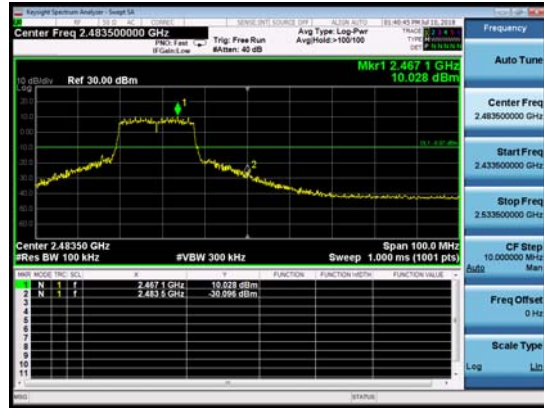

802.11n(HT40), Channel No.: 3



802.11n(HT40), Channel No.: 9



### 5.4. Power Spectral Density

#### Ambient condition

Temperature	Relative humidity	Pressure
23°C ~25°C	45%~50%	101.5kPa

#### Method of Measurement

During the process of the testing, The EUT was connected to Spectrum Analyzer with a known loss. The EUT is max power transmission with proper modulation. Method AVGPSD-2 in KDB558074 D01 was used for this test.

The conducted Power is measured at each antenna port. The measured results at the various antenna ports are then summed mathematically.

#### Test setup

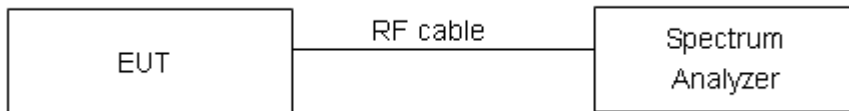

#### Limits

Rule Part 15.247(e) specifies that” For digitally modulated systems, the power spectral density conducted from the intentional radiator to the antenna shall not be greater than 8 dBm in any 3 kHz band during any time interval of continuous transmission. ”

Limits	≤ 8 dBm / 3kHz
--------	----------------

#### Measurement Uncertainty

The assessed measurement uncertainty to ensure 95% confidence level for the normal distribution is with the coverage factor  $k = 2$ ,  $U = 0.75\text{dB}$ .

**Test Results:****SISO Antenna 1**

Network Standards	Channel Number	Read Value (dBm / 3kHz)	Power Spectral Density (dBm / 3kHz)	Limit (dBm / 3kHz)	Conclusion
802.11b	1	-9.09	-8.87	8	PASS
	6	-8.62	-8.40	8	PASS
	11	-8.28	-8.06	8	PASS
802.11g	1	-14.99	-14.77	8	PASS
	6	-14.37	-14.16	8	PASS
	11	-14.26	-14.04	8	PASS

Note: Power Spectral Density =Read Value+Duty cycle correction factor

**SISO Antenna 2**

Network Standards	Channel Number	Read Value (dBm / 3kHz)	Power Spectral Density (dBm / 3kHz)	Limit (dBm / 3kHz)	Conclusion
802.11g	1	-14.59	-14.38	8	PASS
	6	-13.80	-13.58	8	PASS
	11	-13.82	-13.61	8	PASS

Note: Power Spectral Density =Read Value+Duty cycle correction factor

**MIMO**

Network Standards	Channel Number	Power Spectral Density				Total PSD (dBm / 3kHz)	Limit (dBm / 3kHz)	Conclusion
		Antenna 1		Antenna 2				
		Read Value (dBm / 3kHz)	Power Spectral Density (dBm / 3kHz)	Read Value (dBm / 3kHz)	Power Spectral Density (dBm / 3kHz)			
802.11n HT20	1	-15.05	-14.81	-14.87	-14.64	-11.72	7.99	PASS
	6	-14.39	-14.16	-14.20	-13.96	-11.05	7.99	PASS
	11	-14.46	-14.22	-14.11	-13.88	-11.04	7.99	PASS
802.11n HT40	3	-17.60	-17.21	-17.63	-17.24	-14.21	7.99	PASS
	6	-18.26	-17.86	-16.92	-16.53	-14.13	7.99	PASS
	9	-18.12	-17.73	-16.64	-16.25	-13.92	7.99	PASS

Note: 1.Power Spectral Density =Read Value+Duty cycle correction factor  
 2. For Total PSD, according to KDB 662911 D01 Multiple Transmitter Output v02r01 2)a),the power spectral density= $10\log(10^{(PSD\ antenna1\ in\ dBm/10)}+10^{(PSD\ antenna2\ in\ dBm/10)})$   
 3. The manufacturer declared the transmitter output signals is CDD mode. And  $N_{ss}=1$ . According to KDB 662911 D01 Multiple Transmitter Output v02r01 2)f)(i): If all antennas have the same gain, Directional gain =  $G_{ANT} + \text{Array Gain}$ , For PSD measurements on all devices, Array Gain= $10\log(Nant/Nss)$ dB,so directional gain= $G_{ANT}+\text{Array Gain}=3+10\log(2/1)=6.01 >6$ dB. So the power limit is  $8+6-\text{MAX}(6,6.01)$ dBm=7.99 dBm



SISO Antenna 1

802.11b, Channel No.: 1



802.11g, Channel No.: 1



802.11b, Channel No.: 6



802.11g, Channel No.: 6



802.11b, Channel No.: 11



802.11g, Channel No.: 11







SISO Antenna 2

802.11g, Channel No.: 1

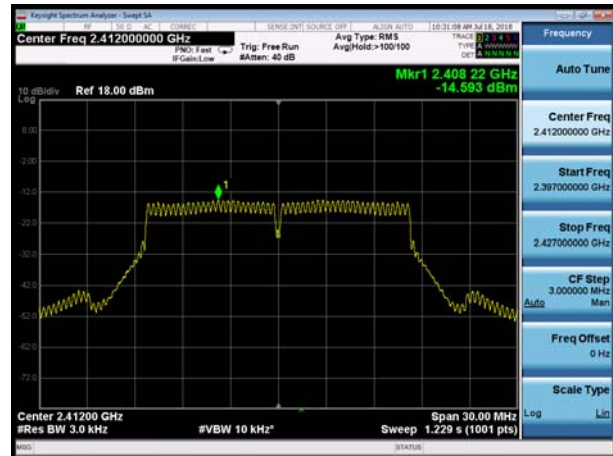

802.11g, Channel No.: 6



802.11g, Channel No.: 11

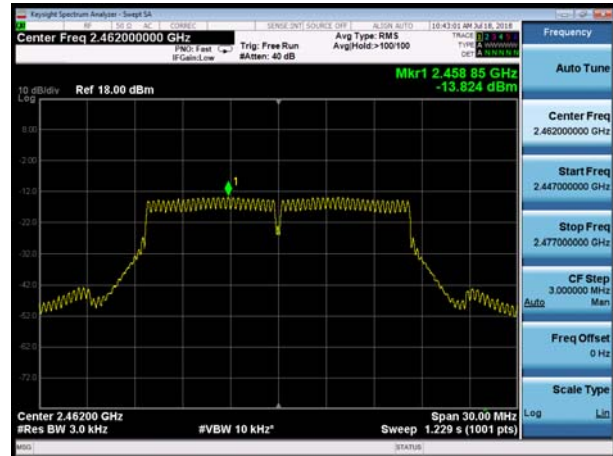



MIMO Antenna 1

802.11n(HT20), Channel No. 1



802.11n(HT40), Channel No. 3



802.11n(HT20), Channel No. 6



802.11n(HT40), Channel No. 6



802.11n(HT20), Channel No. 11



802.11n(HT40), Channel No. 9





MIMO Antenna 2

802.11n(HT20), Channel No. 1



802.11n(HT40), Channel No. 3

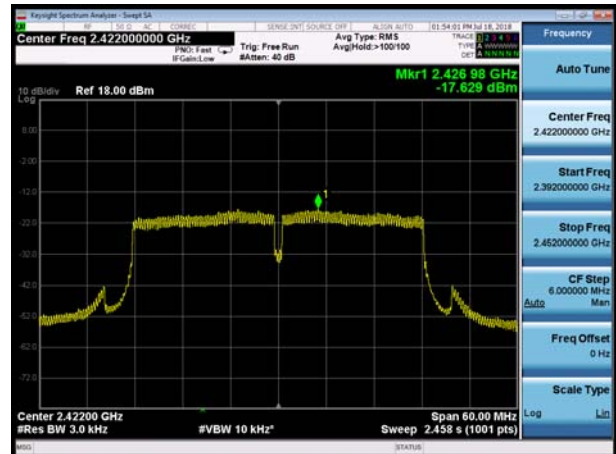

802.11n(HT20), Channel No. 6



802.11n(HT40), Channel No. 6

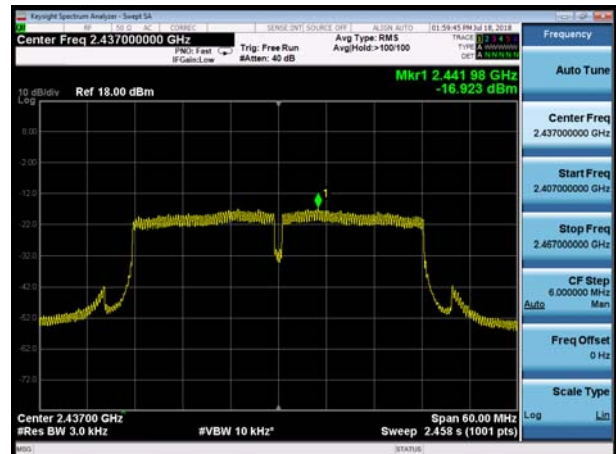

802.11n(HT20), Channel No. 11



802.11n(HT40), Channel No. 9

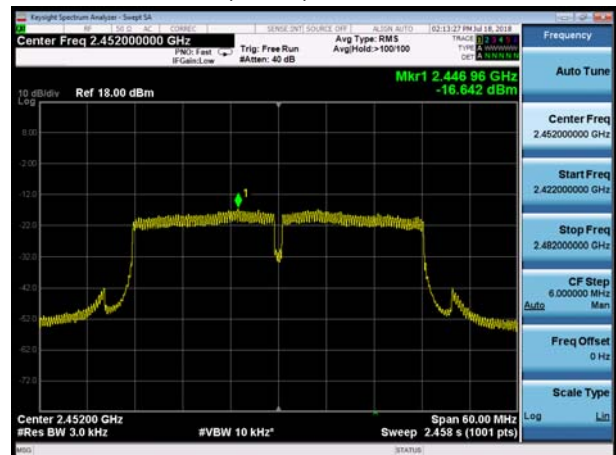

### 5.5. Spurious RF Conducted Emissions

**Ambient condition**

Temperature	Relative humidity	Pressure
23°C ~25°C	45%~50%	101.5kPa

**Method of Measurement**

The EUT was connected to the spectrum analyzer with a known loss. The spectrum analyzer scans from 30MHz to the 10th harmonic of the carrier. The peak detector is used. Set RBW to100kHz and VBW to 300 kHz, Sweep is set to ATUO.

The test is in transmitting mode.

**Test setup**



**Limits**

Rule Part 15.247(d) pacifies that “In any 100 kHz bandwidth outside the frequency band in which the spread spectrum or digitally modulated intentional radiator is operating, the radio frequency power that is produced by the intentional radiator shall be at least 20 dB below that in the 100 kHz bandwidth within the band that contains the highest level of the desired power, based on either an RF conducted or a radiated measurement, provided the transmitter demonstrates compliance with the peak conducted power limits. If the transmitter complies with the conducted power limits based on the use of RMS averaging over a time interval, as permitted under paragraph (b)(3) of this section, the attenuation required under this paragraph shall be 30 dB instead of 20 dB.”

Network Standards	Carrier frequency (MHz)	Reference value (dBm)	Limit
802.11b (SISO Antenna 1)	2412	13.89	-16.11
	2437	14.87	-15.13
	2462	14.88	-15.12
802.11g (SISO Antenna 2)	2412	5.44	-24.56
	2437	9.61	-20.39
	2462	4.97	-25.03
802.11n HT20 (MIMO Antenna 2)	2412	5.35	-24.65
	2437	11.44	-18.56
	2462	3.72	-26.28
802.11n HT40 (MIMO Antenna 2)	2422	1.69	-28.31
	2437	5.52	-24.48
	2452	0.33	-29.67



### Measurement Uncertainty

The assessed measurement uncertainty to ensure 95% confidence level for the normal distribution is with the coverage factor  $k = 1.96$ .

Frequency	Uncertainty
100kHz-2GHz	0.684 dB
2GHz-26GHz	1.407 dB



Test Results:

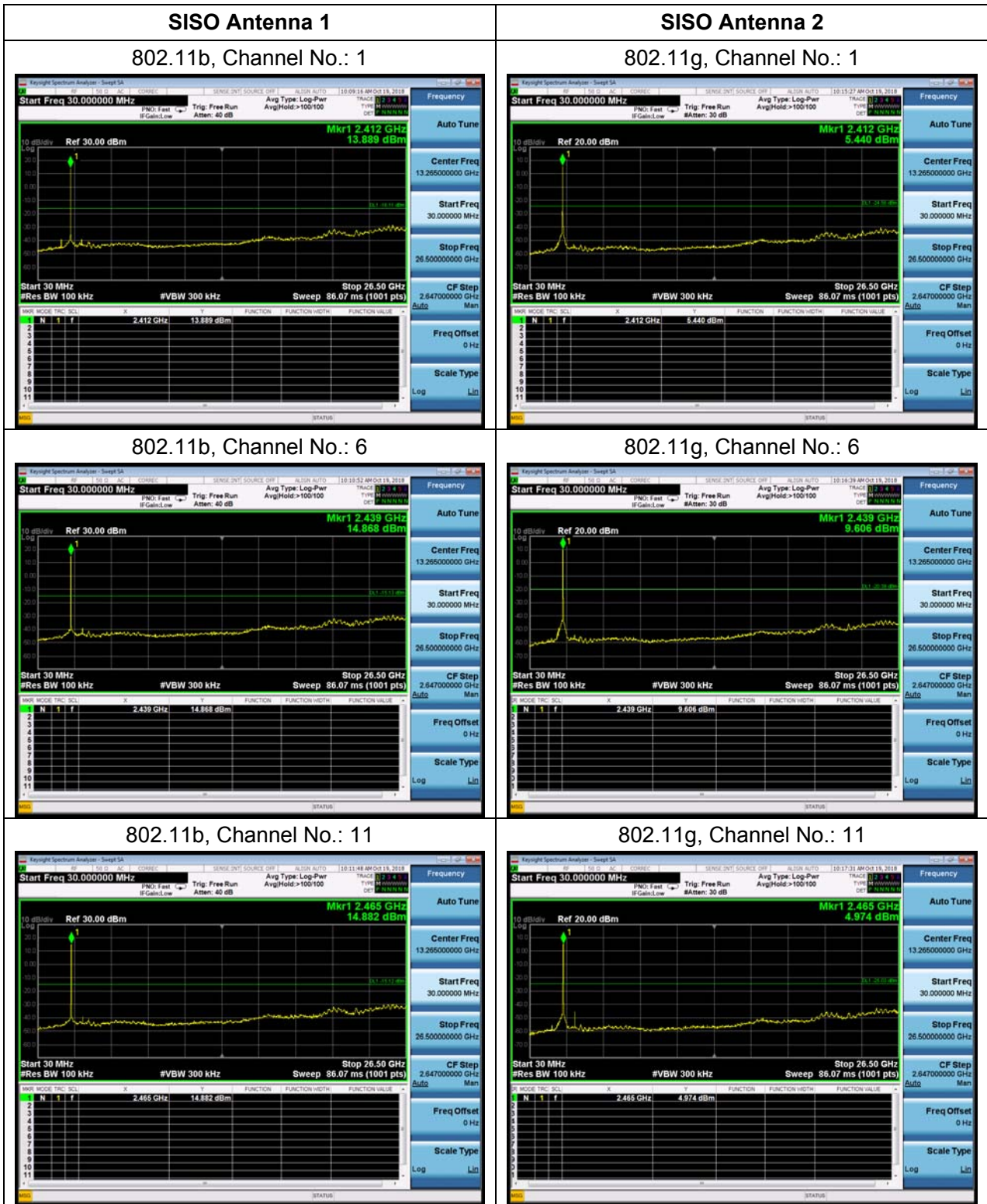

MIMO Antenna 2

802.11n(HT20), Channel No. 1

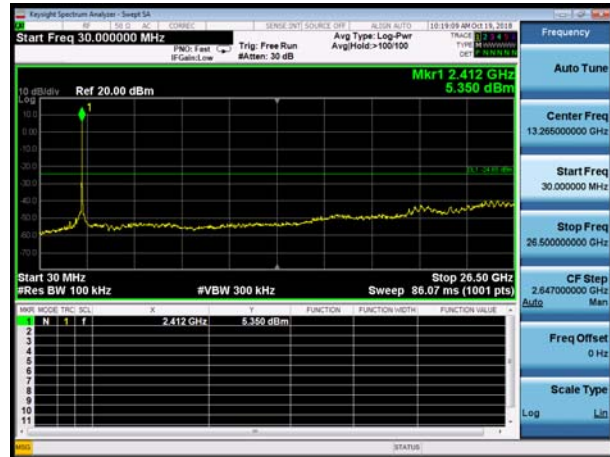

802.11n(HT40), Channel No. 3

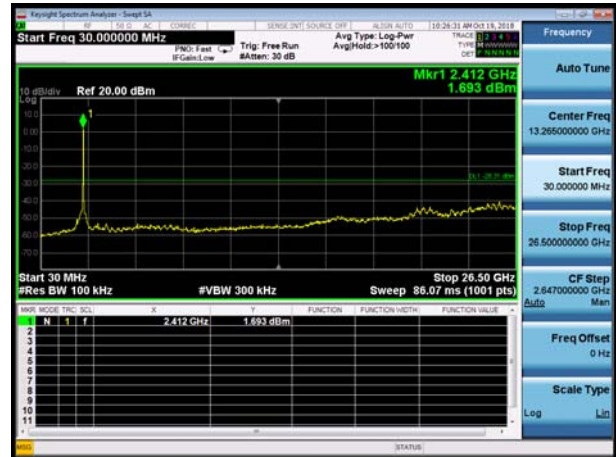

802.11n(HT20), Channel No. 6

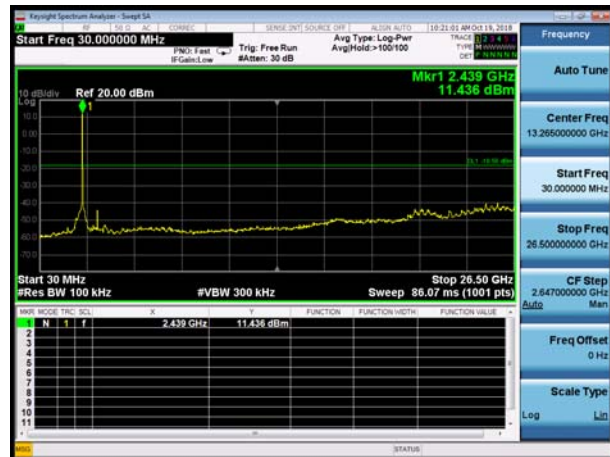

802.11n(HT40), Channel No. 6

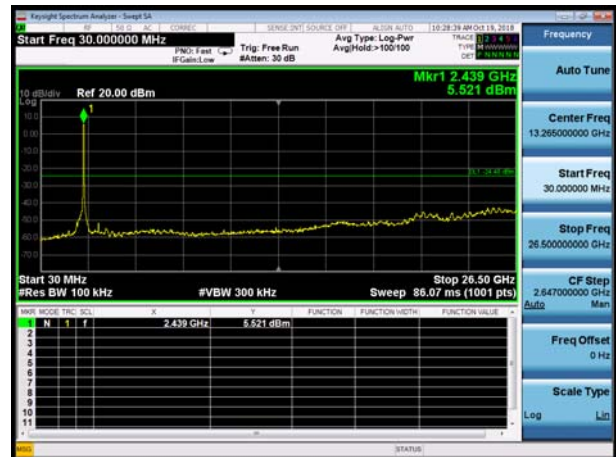

802.11n(HT20), Channel No. 11

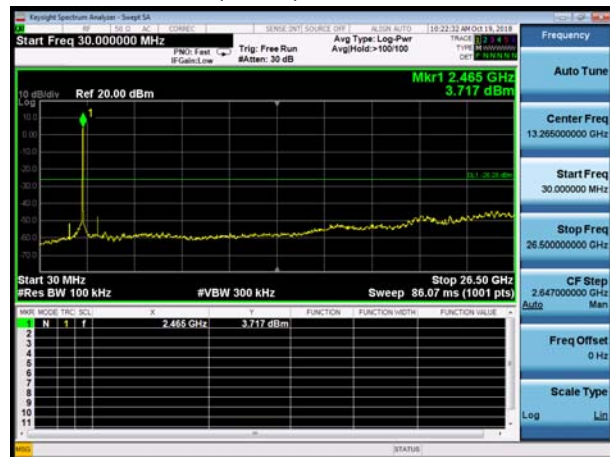

802.11n(HT40), Channel No. 9

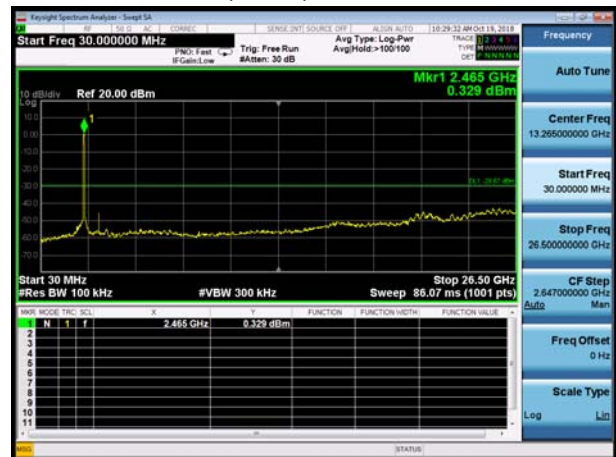

## 5.6. Unwanted Emission

### Ambient condition

Temperature	Relative humidity	Pressure
23°C ~25°C	45%~50%	102.5kPa

### Method of Measurement

The test set-up was made in accordance to the general provisions of ANSI C63.10-2013.

The Equipment Under Test (EUT) was set up on a non-conductive table in the semi-anechoic chamber. The test was performed at the distance of 3 m between the EUT and the receiving antenna.

The turntable shall be rotated from 0 to 360 degrees for detecting the maximum of radiated spurious signal level. The measurements shall be repeated with orthogonal polarization of the test antenna. The data of cable loss and antenna factor has been calibrated in full testing frequency range before the testing. Sweep the Restricted Band and the emissions less than 20 dB below the permissible value are reported.

The radiated emissions measurements were made in a typical installation configuration.

Sweep the whole frequency band through the range from 9 kHz to the 10th harmonic of the carrier, and the emissions less than 20 dB below the permissible value are reported.

This method refer to KDB 558074.

The procedure for peak unwanted emissions measurements above 1000 MHz is as follows:

I) Peak emission levels are measured by setting the instrument as follows:

- 1) RBW = 1 MHz.
- 2) VBW  $\geq$  [3  $\times$  RBW]
- 3) Detector = peak.
- 4) Sweep time = auto.
- 5) Trace mode = max hold.
- 6) Allow sweeps to continue until the trace stabilizes. Note that if the transmission is not continuous, then the time required for the trace to stabilize will increase by a factor of approximately 1 / D, where D is the duty cycle.

II) Average emission levels are measured by setting the instrument as follows:

- a) RBW = 1 MHz.
- b) VBW  $\geq$  [3  $\times$  RBW].
- c) Detector = RMS (power averaging), if [span / (# of points in sweep)]  $\leq$  RBW / 2. Satisfying this condition can require increasing the number of points in the sweep or reducing the span. If the condition is not satisfied, then the detector mode shall be set to peak.
- d) Averaging type = power (i.e., rms) (As an alternative, the detector and averaging type may be set for linear voltage averaging. Some instruments require linear display mode to use linear voltage



averaging. Log or dB averaging shall not be used.)

e) Sweep time = auto.

f) Perform a trace average of at least 100 traces if the transmission is continuous. If the transmission is not continuous, then the number of traces shall be increased by a factor of  $1 / D$ , where  $D$  is the duty cycle. For example, with 50% duty cycle, at least 200 traces shall be averaged. (If a specific emission is demonstrated to be continuous—i.e., 100% duty cycle—then rather than turning ON and OFF with the transmit cycle, at least 100 traces shall be averaged.)

g) If tests are performed with the EUT transmitting at a duty cycle less than 98%, then a correction factor shall be added to the measurement results prior to comparing with the emission limit, to compute the emission level that would have been measured had the test been performed at 100% duty cycle. The correction factor is computed as follows:

1) If power averaging (rms) mode was used in the preceding step e), then the correction factor is  $[10 \log (1 / D)]$ , where  $D$  is the duty cycle. For example, if the transmit duty cycle was 50%, then 3 dB shall be added to the measured emission levels.

2) If linear voltage averaging mode was used in the preceding step e), then the correction factor is  $[20 \log (1 / D)]$ , where  $D$  is the duty cycle. For example, if the transmit duty cycle was 50%, then 6 dB shall be added to the measured emission levels.

3) If a specific emission is demonstrated to be continuous (100% duty cycle) rather than turning ON and OFF with the transmit cycle, then no duty cycle correction is required for that emission.

The field strength of spurious emission was measured in the following position: EUT stand-up position (Z axis), lie-down position (X, Y axis). The worst emission was found in stand-up position (Z axis) and the antenna is vertical.

The test is in transmitting mode.

**Test setup**

**9KHz ~ 30MHz**

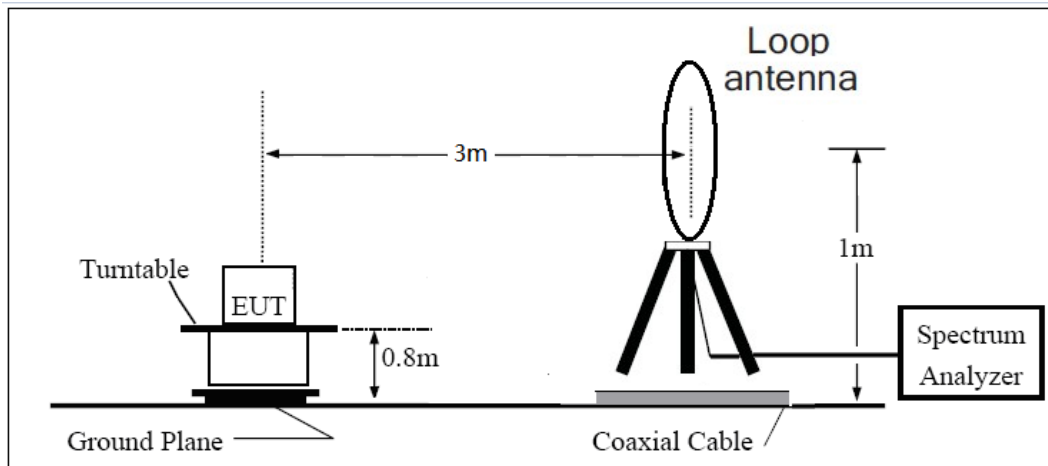

**30MHz ~ 1GHz**

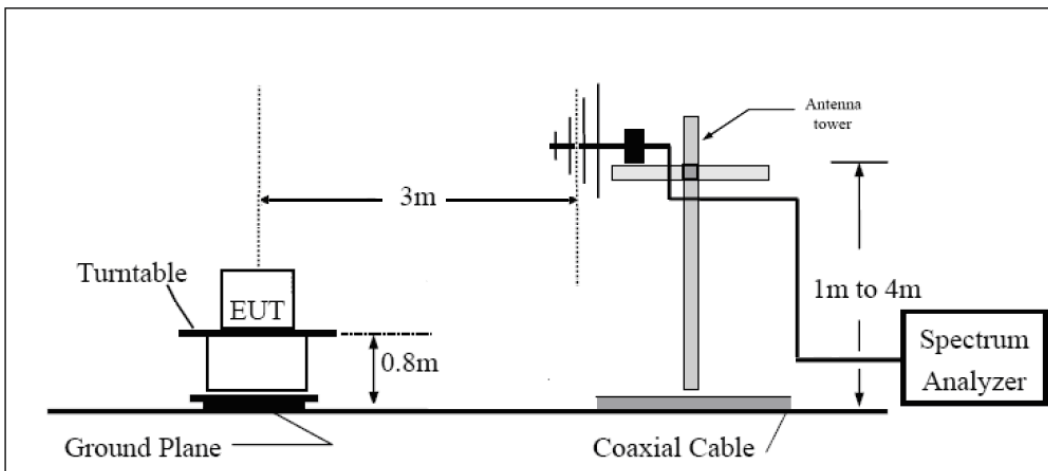

**Above 1GHz**

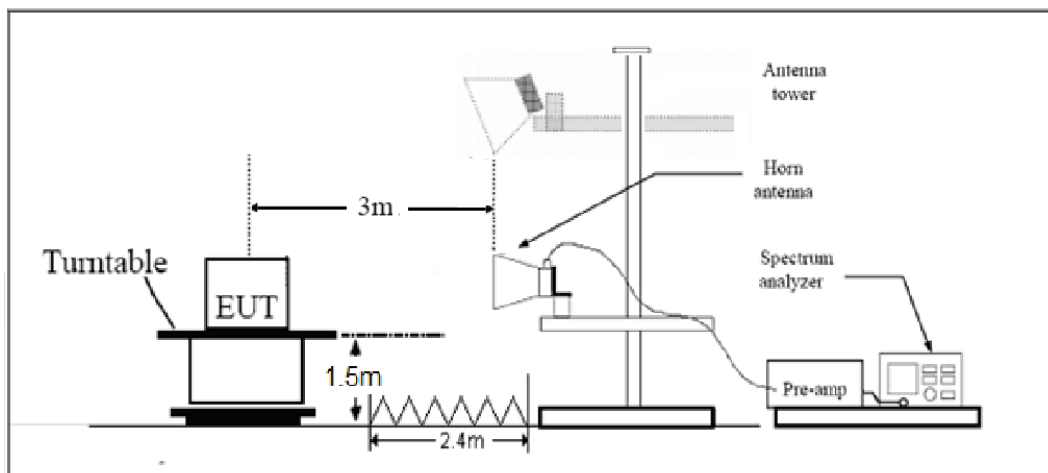

Note: Area side:2.4mX3.6m

**Limits**

Rule Part 15.247(d) specifies that “In addition, radiated emissions which fall in the restricted bands, as defined in § 15.205(a), must also comply with the radiated emission limits specified in § 15.209(a) (see § 15.205(c)).”

Limit in restricted band

Frequency of emission (MHz)	Field strength(uV/m)	Field strength(dBuV/m)
0.009–0.490	2400/F(kHz)	/
0.490–1.705	24000/F(kHz)	/
1.705–30.0	30	/
30-88	100	40
88-216	150	43.5
216-960	200	46
Above960	500	54

§15.35(b)

There is also a limit on the radio frequency emissions, as measured using instrumentation with a peak detector function, corresponding to 20 dB above the maximum permitted average limit.

Peak Limit=74 dBuV/m

Average Limit=54 dBuV/m

Spurious Radiated Emissions are permitted in any of the frequency bands listed below:

MHz	MHz	MHz	GHz
0.090 - 0.110	16.42 - 16.423	399.9 - 410	4.5 - 5.15
0.495 - 0.505	16.69475 - 16.69525	608 - 614	5.35 - 5.46
2.1735 - 2.1905	16.80425 - 16.80475	960 - 1240	7.25 - 7.75
4.125 - 4.128	25.5 - 25.67	1300 - 1427	8.025 - 8.5
4.17725 - 4.17775	37.5 - 38.25	1435 - 1626.5	9.0 - 9.2
4.20725 - 4.20775	73 - 74.6	1645.5 - 1646.5	9.3 - 9.5
6.215 - 6.218	74.8 - 75.2	1660 - 1710	10.6 - 12.7
6.26775 - 6.26825	108 - 121.94	1718.8 - 1722.2	13.25 - 13.4
6.31175 - 6.31225	123 - 138	2200 - 2300	14.47 - 14.5
8.291 - 8.294	149.9 - 150.05	2310 - 2390	15.35 - 16.2
8.362 - 8.366	156.52475 - 156.52525	2483.5 - 2500	17.7 - 21.4
8.37625 - 8.38675	156.7 - 156.9	2690 - 2900	22.01 - 23.12
8.41425 - 8.41475	162.0125 - 167.17	3260 - 3267	23.6 - 24.0
12.29 - 12.293	167.72 - 173.2	3332 - 3339	31.2 - 31.8
12.51975 - 12.52025	240 - 285	3345.8 - 3358	36.43 - 36.5
12.57675 - 12.57725	322 - 335.4	3600 - 4400	( <sup>2</sup> )
13.36 - 13.41			

**Measurement Uncertainty**

The assessed measurement uncertainty to ensure 95% confidence level for the normal distribution is with the coverage factor  $k = 1.96$ .

Frequency	Uncertainty
9KHz-30MHz	3.55 dB
30MHz-200MHz	4.19 dB
200MHz-1GHz	3.63 dB
Above 1GHz	3.68 dB



Test Results:

SISO Antenna 1

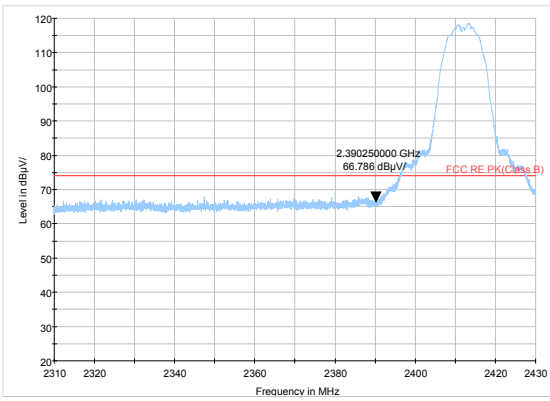

802.11b-Channel 1 Peak

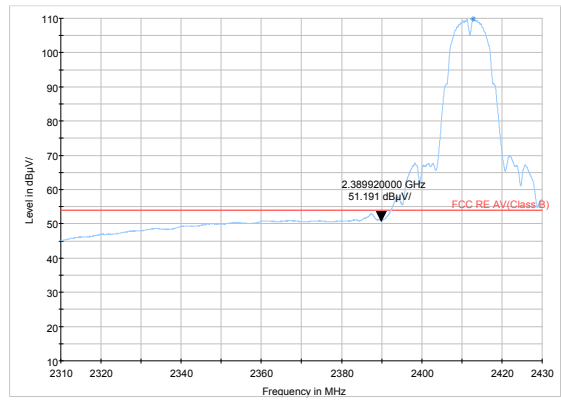

802.11b-Channel 1 Average

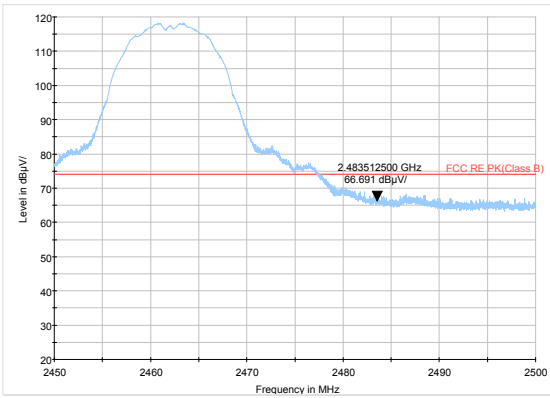

802.11b-Channel 11 Peak

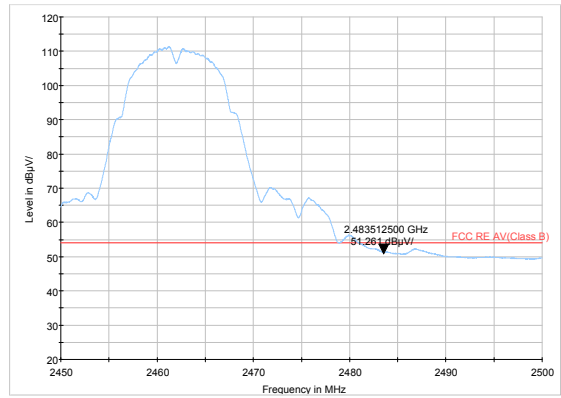

802.11b-Channel 11 Average



SISO Antenna 2

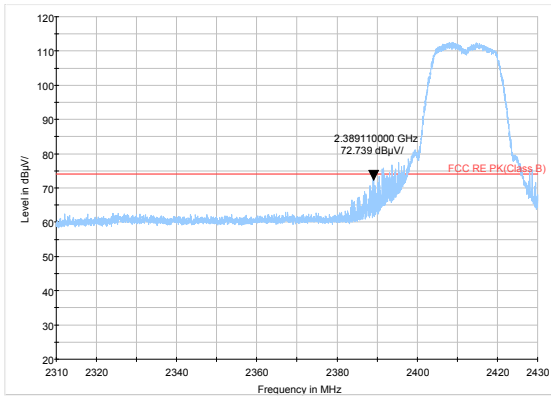

802.11g-Channel 1 Peak

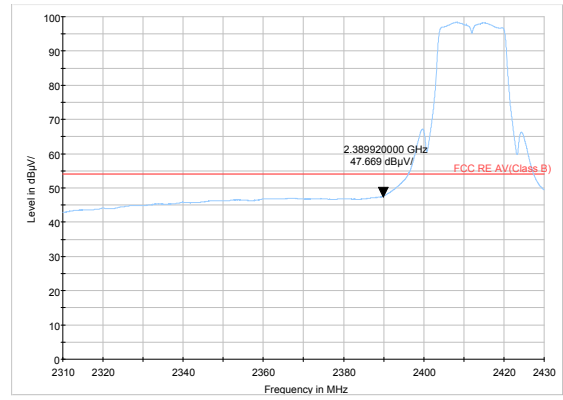

802.11g-Channel 1 Average

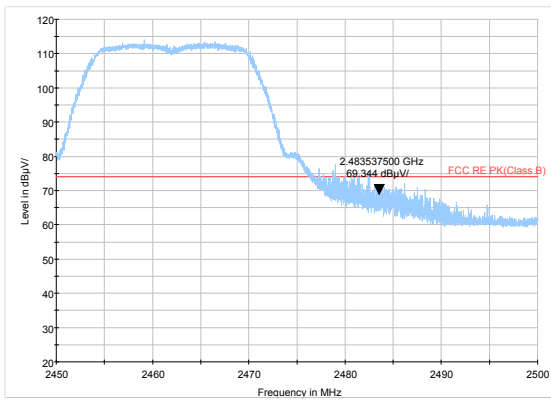

802.11g-Channel 11 Peak

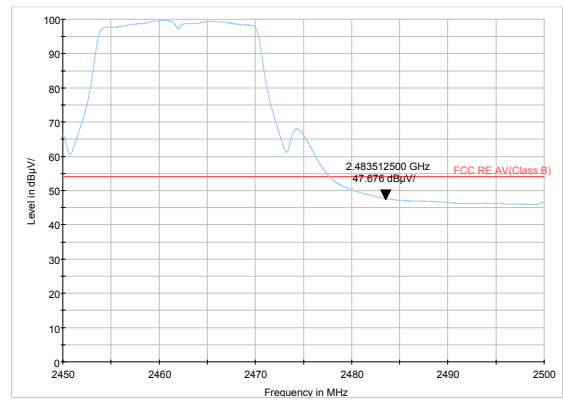

802.11g-Channel 11 Average



MIMO

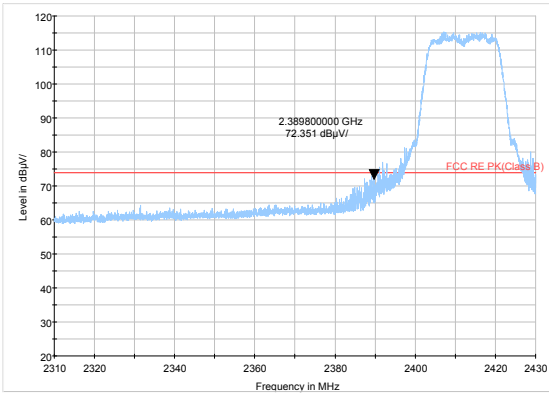

802.11n HT20 -Channel 1 Peak

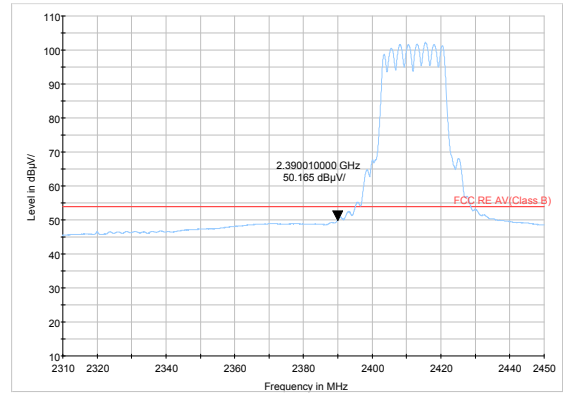

802.11n HT20 -Channel 1 Average

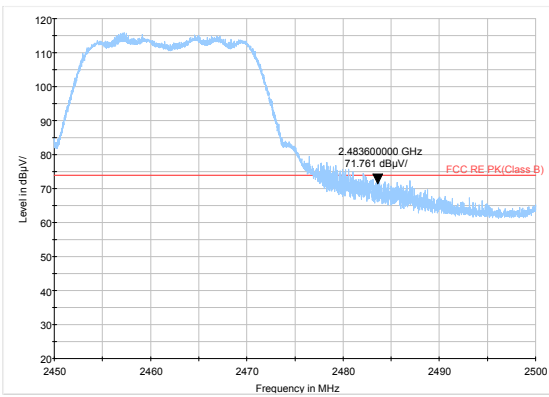

802.11n HT20 -Channel 11 Peak

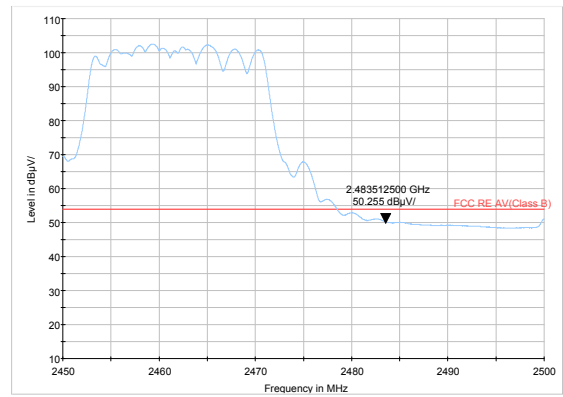

802.11n HT20 -Channel 11 Average

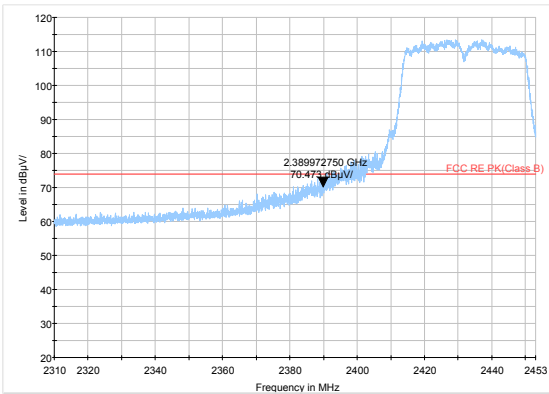

802.11n HT40 -Channel 3 Peak

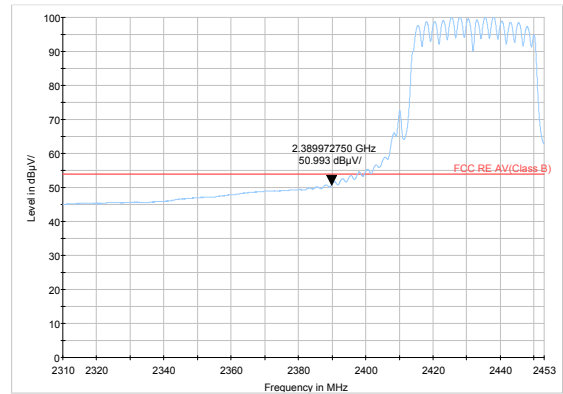

802.11n HT40 -Channel 3 Average

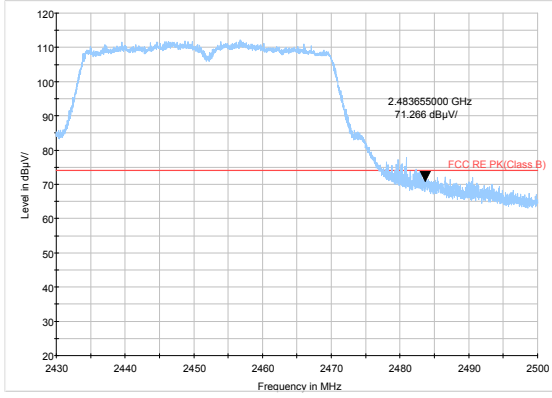

802.11n HT40 -Channel 9 Peak

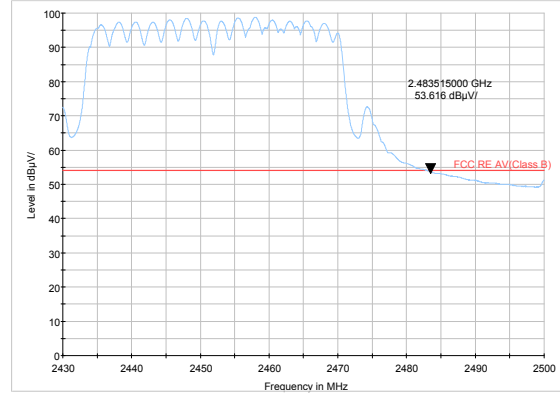

802.11n HT40 -Channel 9 Average



**Result of RE**

**Test result**

Sweep the whole frequency band through the range from 9kHz to the 10th harmonic of the carrier, the Emissions in the frequency band 9kHz-30MHz and 18GHz-26.5GHz are more than 20dB below the limit are not reported.

The following graphs display the maximum values of horizontal and vertical by software. For above 1GHz, Blue trace uses the peak detection, Green trace uses the average detection.

**After the pretest, MIMO was selected as the worst antenna for 802.11n HT20/ HT40. SISO Antenna 1 was selected as the worst SISO antenna for 802.11b. SISO Antenna 2 was selected as the worst SISO antenna for 802.11g.**

During the test, the Radiates Emission from 30MHz to 1GHz was performed in all modes with all channels, 802.11b, Channel 11 are selected as the worst condition. The test data of the worst-case condition was recorded in this report.

**Continuous TX mode:**

RE 30M-1GHz QP

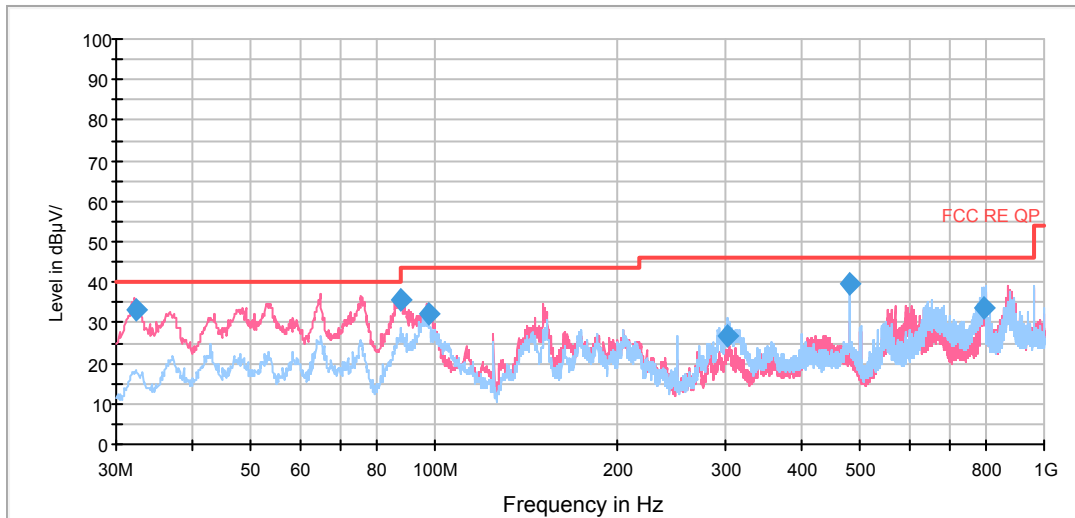

Radiates Emission from 30MHz to 1GHz

Frequency (MHz)	Quasi-Peak (dBuV/m)	Reading value (dBuV/m)	Height (cm)	Polarization	Azimuth (deg)	Correct Factor (dB)	Margin (dB)	Limit (dBuV/m)
32.262956	33.1	52.2	100.0	V	114.0	-19.1	6.9	40.0
87.896660	35.6	59.8	120.0	V	211.0	-24.2	4.4	40.0
97.409569	32.2	56.0	100.0	V	147.0	-23.8	11.3	43.5
302.205250	26.9	49.3	100.0	H	229.0	-22.4	19.1	46.0
480.000000	39.5	59.2	175.0	H	230.0	-19.7	6.5	46.0
798.943500	33.6	50.2	200.0	H	0.0	-16.6	12.4	46.0

- Remark:**
1. Quasi-Peak = Reading value + Correction factor
  2. Correction Factor = Antenna factor+ Insertion loss(cable loss+amplifier gain)
  3. Margin = Limit – Quasi-Peak

**SISO Antenna 1**  
**802.11b CH1**

RE 1G-3GHz PK+AV

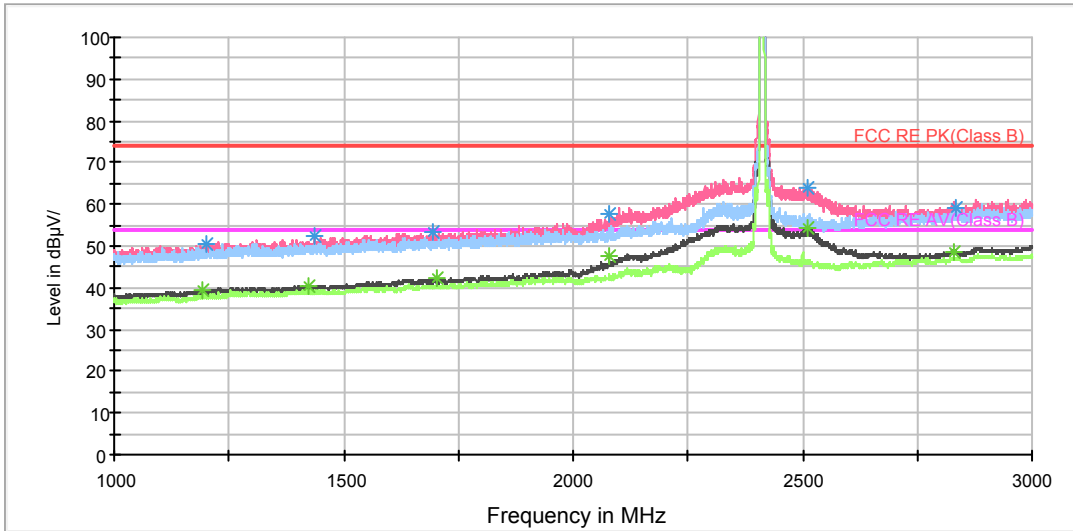

Note: The signal beyond the limit is carrier.  
Radiates Emission from 1GHz to 3GHz

RE 3-18GHz PK+AV

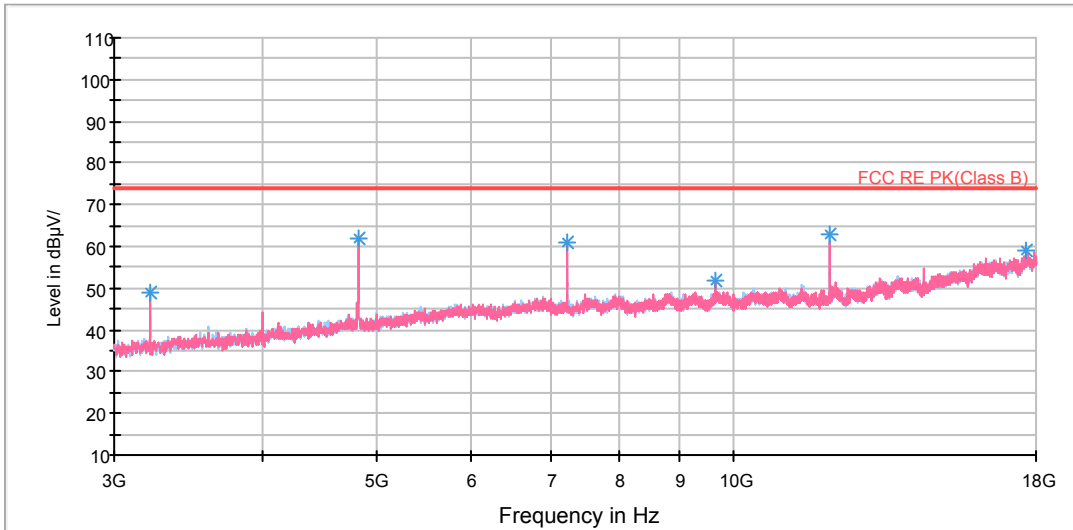

RE 3-18GHz AV

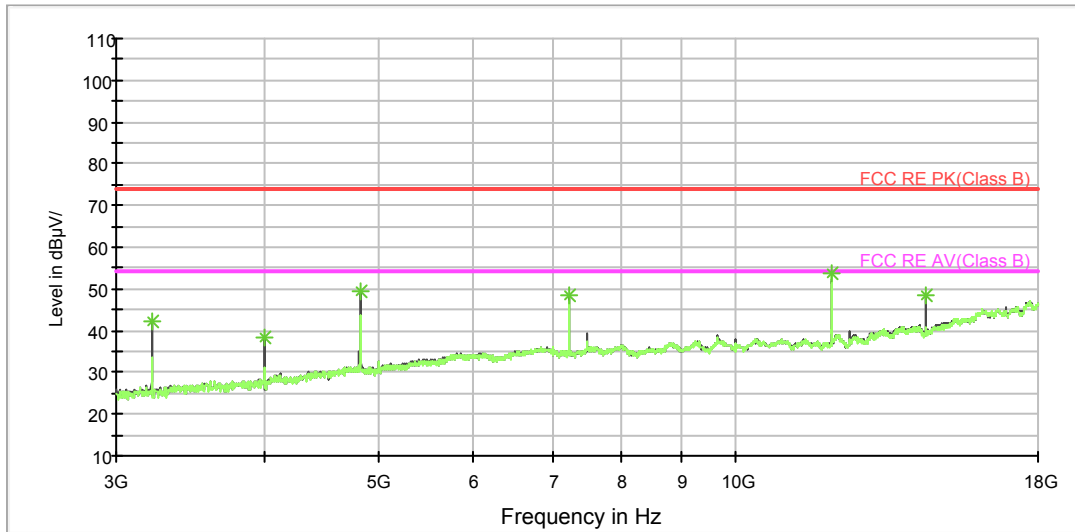

Radiates Emission from 3GHz to 18GHz

Frequency (MHz)	Peak (dBuV/m)	Height (cm)	Polarization	Azimuth (deg)	Reading value (dBuV/m)	Correct Factor (dB)	Margin (dB)	Limit (dBuV/m)
1200.500000	50.4	200.0	V	0.0	48.6	1.8	23.6	74
1435.250000	52.4	200.0	V	164.0	49.3	3.1	21.6	74
1693.250000	53.6	200.0	V	246.0	48.6	5.0	20.4	74
2080.000000	57.5	200.0	V	104.0	50.5	7.0	16.5	74
2832.000000	58.9	200.0	V	73.0	47.3	11.6	15.1	74

Remark: 1. Correction Factor = Antenna factor+ Insertion loss (cable loss + amplifier gain)

Frequency (MHz)	Average (dBuV/m)	Height (cm)	Polarization	Azimuth (deg)	Reading value (dBuV/m)	Correct Factor (dB)	Margin (dB)	Limit (dBuV/m)
1191.500000	39.3	200.0	V	228.0	37.5	1.8	14.7	54
1422.500000	40.5	200.0	V	0.0	37.4	3.1	13.5	54
1704.500000	42.1	200.0	V	0.0	37.0	5.1	11.9	54
2080.000000	47.7	200.0	V	104.0	40.7	7.0	6.3	54
2829.250000	48.7	200.0	V	0.0	37.1	11.6	5.3	54

Remark: 1. Correction Factor = Antenna factor+ Insertion loss (cable loss + amplifier gain)

802.11b CH6

RE 1G-3GHz PK+AV

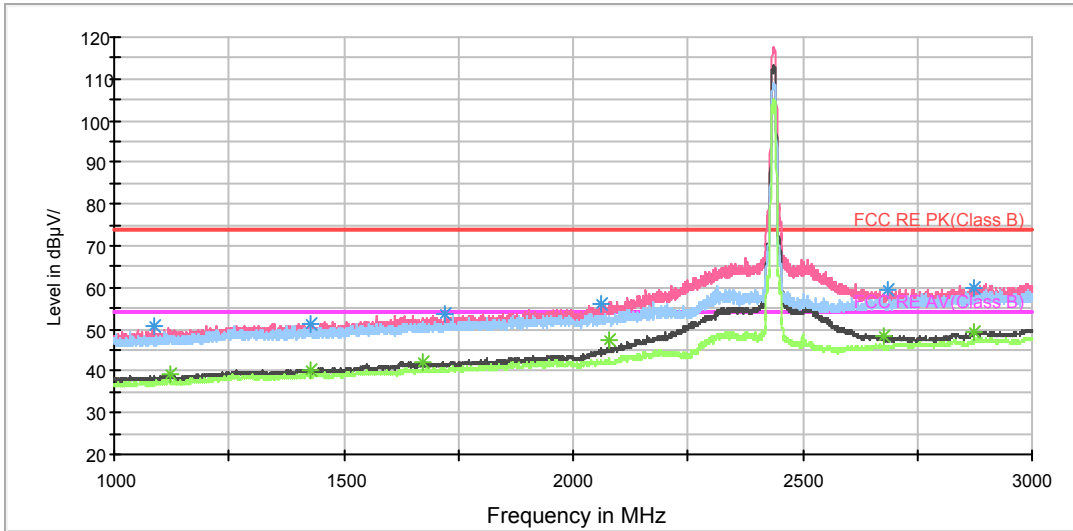

Note: The signal beyond the limit is carrier.  
Radiates Emission from 1GHz to 3GHz

RE 3-18GHz PK+AV

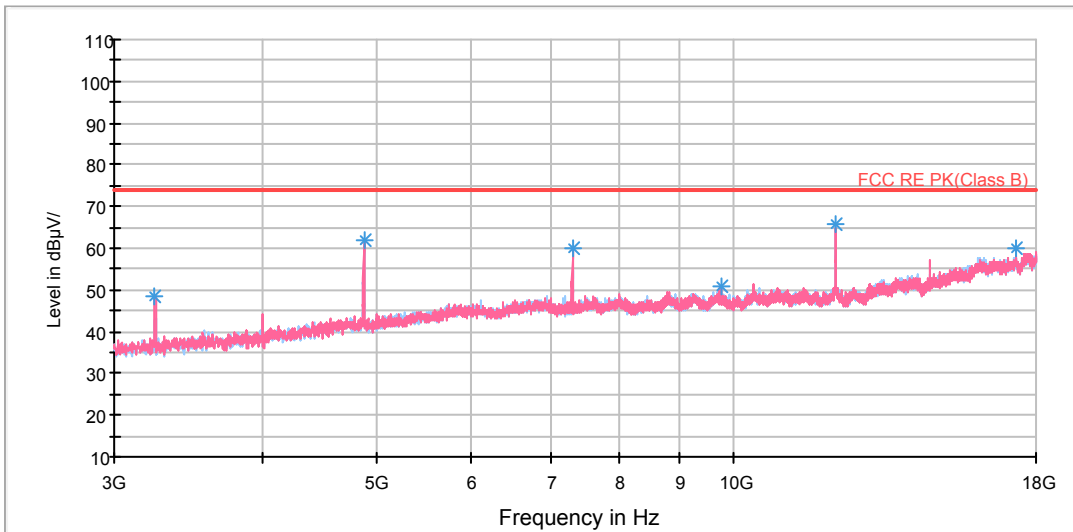

RE 3-18GHz AV

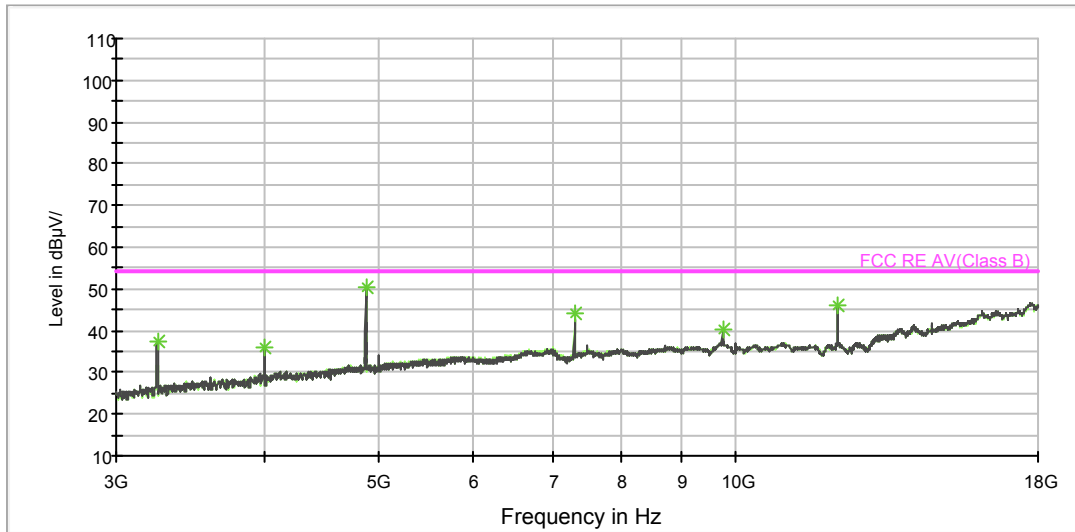

Radiates Emission from 3GHz to 18GHz

Frequency (MHz)	Peak (dBuV/m)	Height (cm)	Polarization	Azimuth (deg)	Reading value (dBuV/m)	Correct Factor (dB)	Margin (dB)	Limit (dBuV/m)
1086.250000	50.7	200.0	V	356.0	49.6	1.1	23.3	74
1427.500000	51.3	200.0	V	344.0	48.2	3.1	22.7	74
1720.750000	53.7	200.0	V	189.0	48.6	5.1	20.3	74
2063.250000	56.2	200.0	V	129.0	49.3	6.9	17.8	74
2874.000000	60.0	200.0	V	257.0	47.7	12.3	14.0	74
2687.000000	59.5	200.0	V	356.0	49.4	10.1	14.5	74

Remark: 1. Correction Factor = Antenna factor+ Insertion loss (cable loss + amplifier gain)

Frequency (MHz)	Average (dBuV/m)	Height (cm)	Polarization	Azimuth (deg)	Reading value (dBuV/m)	Correct Factor (dB)	Margin (dB)	Limit (dBuV/m)
1124.250000	39.2	200.0	V	136.0	37.7	1.5	14.8	54
1429.500000	40.3	200.0	V	234.0	37.2	3.1	13.7	54
1670.500000	42.1	200.0	V	310.0	37.2	4.9	11.9	54
2080.000000	47.2	200.0	V	129.0	40.2	7.0	6.8	54
2873.750000	49.4	200.0	V	280.0	37.1	12.3	4.6	54
2675.250000	48.5	200.0	V	356.0	38.3	10.2	5.5	54

Remark: 1. Correction Factor = Antenna factor+ Insertion loss (cable loss + amplifier gain)

## 802.11b CH11

RE 1G-3GHz PK+AV

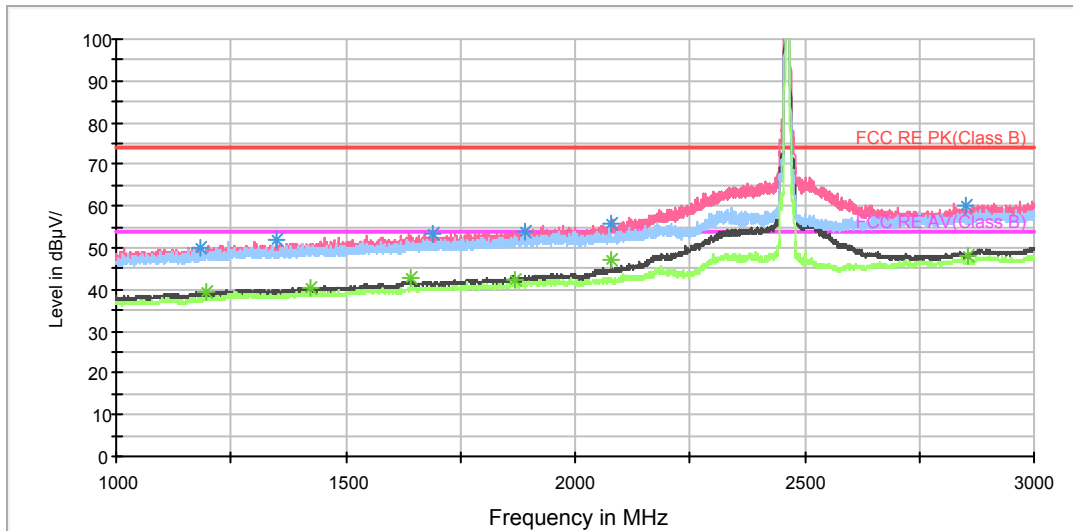

Note: The signal beyond the limit is carrier.  
Radiates Emission from 1GHz to 3GHz

RE 3-18GHz PK+AV

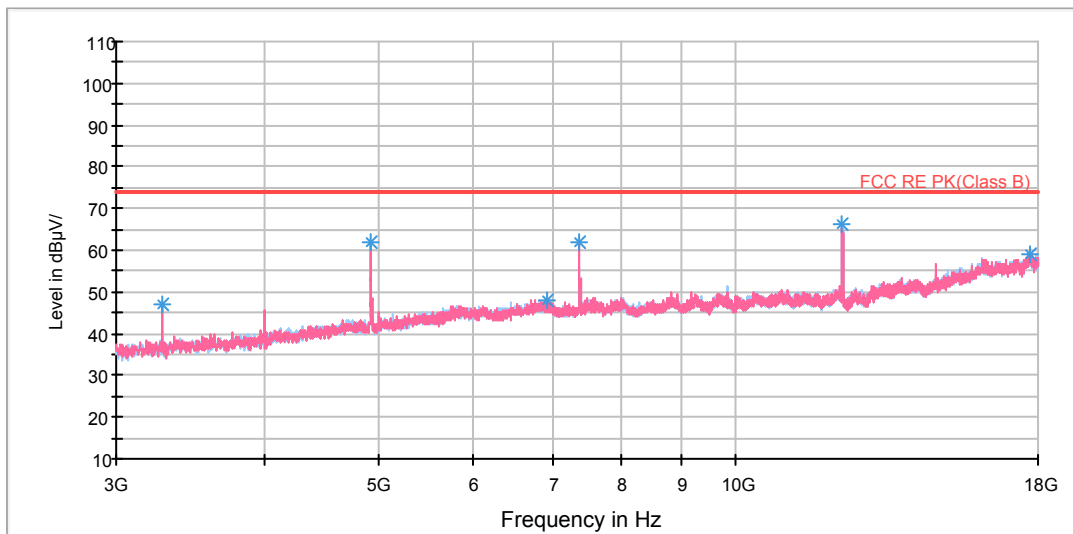

RE 3-18GHz AV

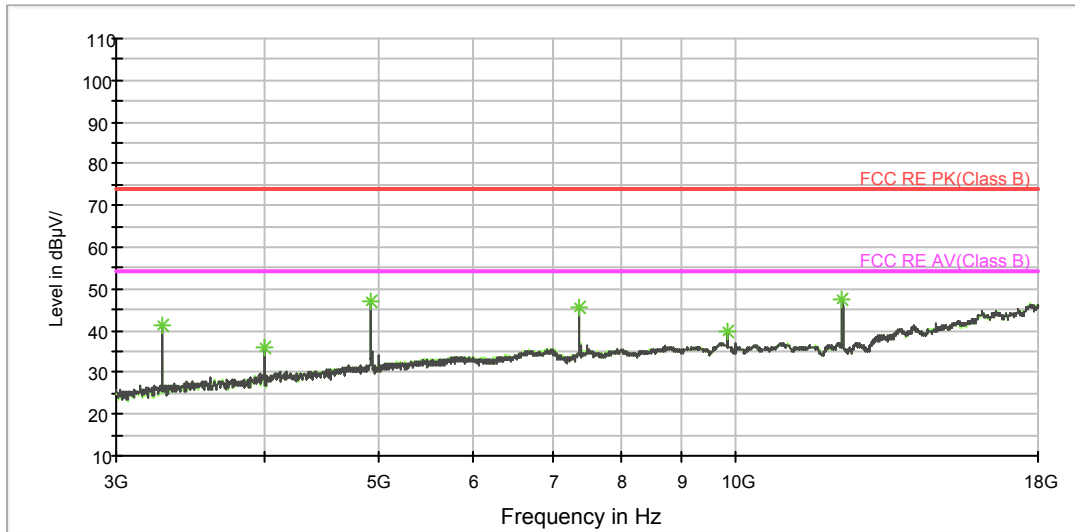

Radiates Emission from 3GHz to 18GHz

Frequency (MHz)	Peak (dBuV/m)	Height (cm)	Polarization	Azimuth (deg)	Reading value (dBuV/m)	Correct Factor (dB)	Margin (dB)	Limit (dBuV/m)
1183.250000	50.2	200.0	V	339.0	48.2	2.0	23.8	74
1347.750000	51.7	200.0	V	0.0	49.2	2.5	22.3	74
1690.500000	53.5	200.0	V	0.0	48.5	5.0	20.5	74
1892.500000	53.8	200.0	V	305.0	48.0	5.8	20.2	74
2077.750000	55.9	200.0	V	119.0	48.9	7.0	18.1	74
2853.500000	60.1	200.0	V	0.0	48.7	11.4	13.9	74

Remark: 1. Correction Factor = Antenna factor+ Insertion loss (cable loss + amplifier gain)

Frequency (MHz)	Average (dBuV/m)	Height (cm)	Polarization	Azimuth (deg)	Reading value (dBuV/m)	Correct Factor (dB)	Margin (dB)	Limit (dBuV/m)
1197.500000	39.3	200.0	V	293.0	37.5	1.8	14.7	54
1425.250000	40.4	200.0	V	282.0	37.3	3.1	13.6	54
1641.250000	42.8	200.0	V	149.0	37.5	5.3	11.2	54
1870.250000	42.5	200.0	V	201.0	36.3	6.2	11.5	54
2079.750000	46.9	200.0	V	101.0	39.9	7.0	7.1	54
2854.750000	48.2	200.0	V	0.0	36.7	11.5	5.8	54

Remark: 1. Correction Factor = Antenna factor+ Insertion loss (cable loss + amplifier gain)

## SISO Antenna 2

## 802.11g CH1

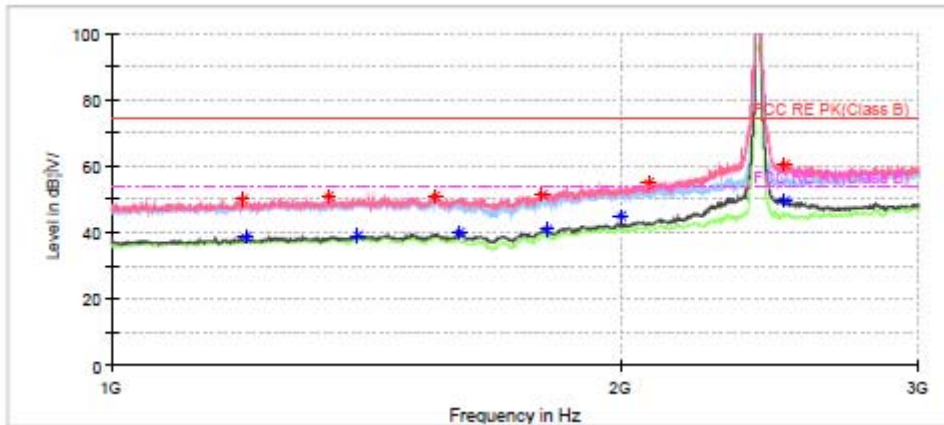

Note: The signal beyond the limit is carrier.

Radiates Emission from 1GHz to 3GHz

RE 3-18GHz PK+AV

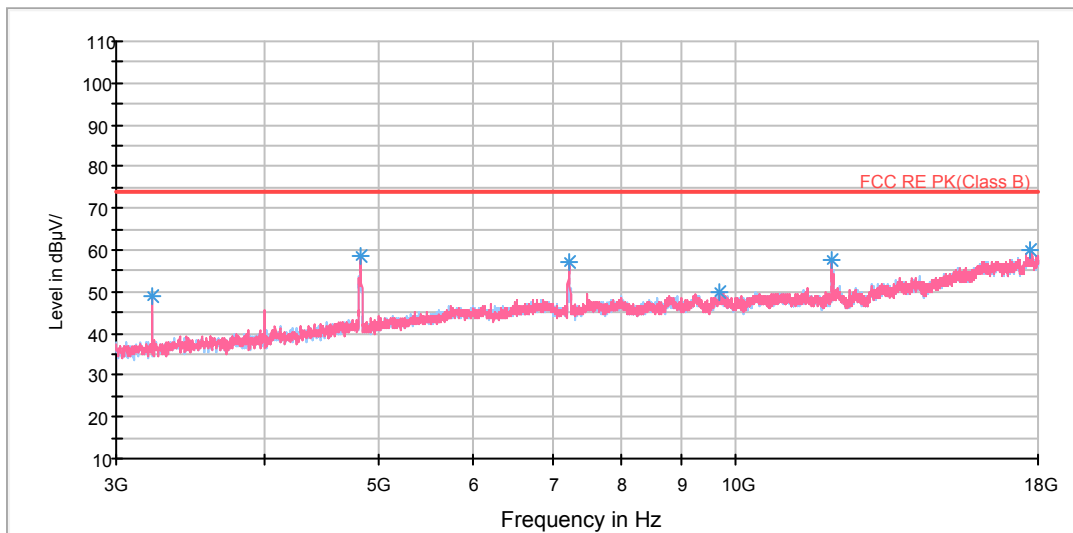



RE 3-18GHz AV

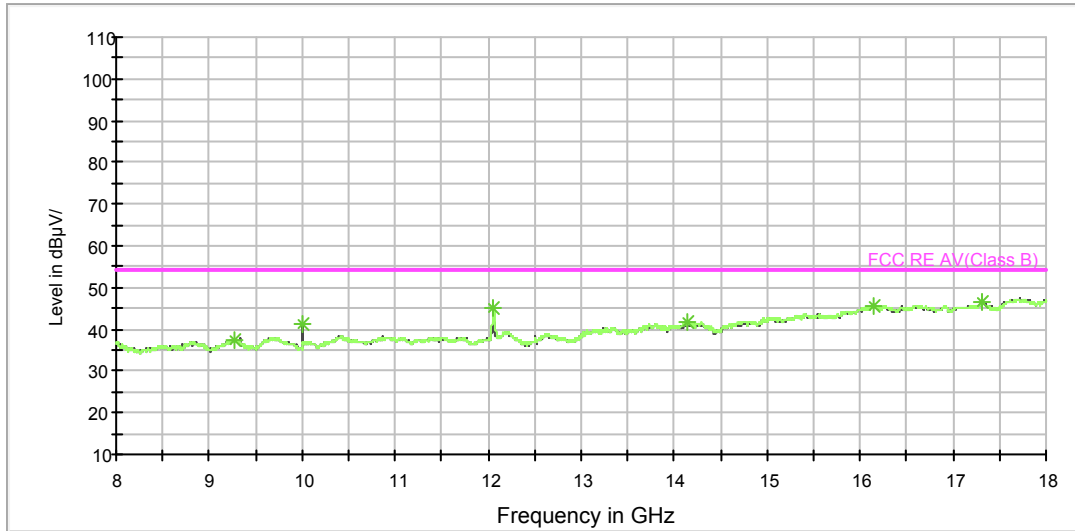

Radiates Emission from 3GHz to 18GHz

Frequency (MHz)	Peak (dBuV/m)	Height (cm)	Polarization	Azimuth (deg)	Reading value (dBuV/m)	Correct Factor (dB)	Margin (dB)	Limit (dBuV/m)
1193.500000	49.8	100.0	H	211.0	48.0	1.8	24.2	74
1344.250000	50.7	200.0	V	214.0	48.2	2.5	23.3	74
1554.000000	50.7	100.0	V	180.0	47.1	3.6	23.3	74
2075.750000	55.0	100.0	V	0.0	48.0	7.0	19.0	74
2498.750000	60.3	200.0	V	345.0	50.4	9.9	13.7	74
3215.625000	44.1	200.0	V	46.0	46.5	-2.4	29.9	74

Remark: 1. Correction Factor = Antenna factor+ Insertion loss (cable loss + amplifier gain)

Frequency (MHz)	Average (dBuV/m)	Height (cm)	Polarization	Azimuth (deg)	Reading value (dBuV/m)	Correct Factor (dB)	Margin (dB)	Limit (dBuV/m)
1200.000000	38.5	200.0	V	145.0	36.7	1.8	15.5	54
1397.750000	39.0	200.0	V	334.0	36.1	2.9	15.0	54
1604.750000	39.8	200.0	V	352.0	36.0	3.8	14.2	54
2000.000000	44.8	200.0	V	322.0	38.2	6.6	9.2	54
2500.000000	49.6	200.0	V	340.0	39.8	9.8	4.4	54
12060.000000	45.2	200.0	H	324.0	34.3	10.9	8.8	54

Remark: 1. Correction Factor = Antenna factor+ Insertion loss (cable loss + amplifier gain)

802.11g CH6

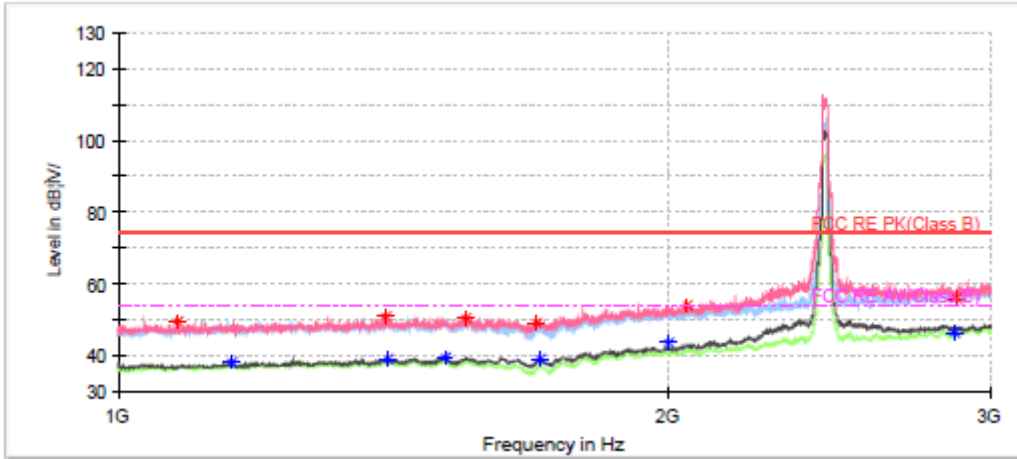

Note: The signal beyond the limit is carrier.  
Radiates Emission from 1GHz to 3GHz

RE 3-18GHz PK+AV

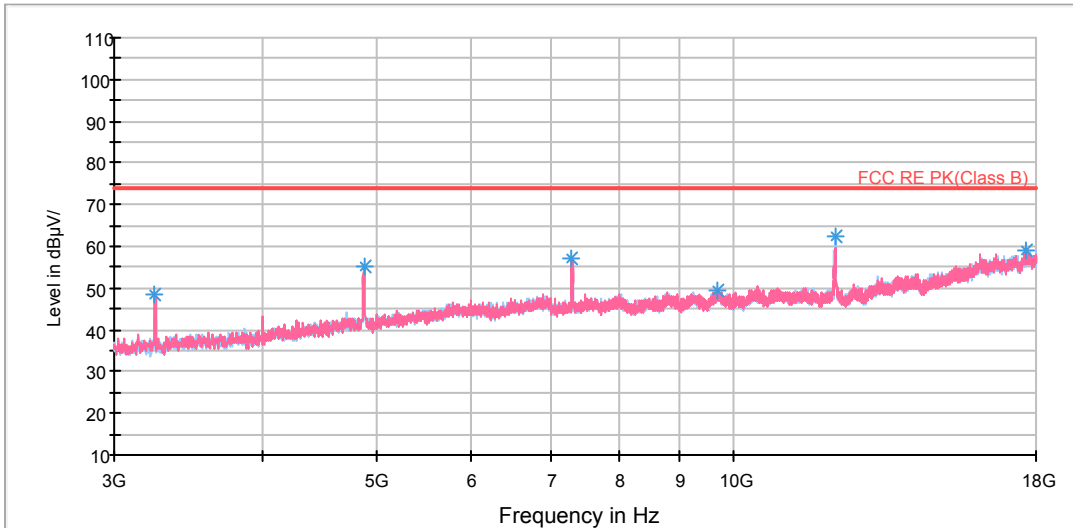

RE 3-18GHz AV

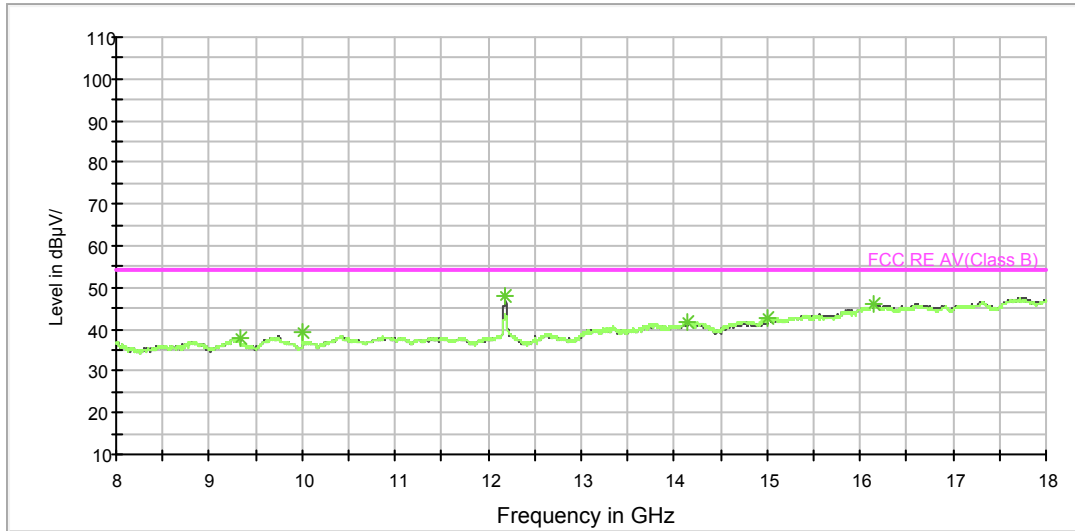

Radiates Emission from 3GHz to 18GHz

Frequency (MHz)	Peak (dBuV/m)	Height (cm)	Polarization	Azimuth (deg)	Reading value (dBuV/m)	Correct Factor (dB)	Margin (dB)	Limit (dBuV/m)
1079.000000	49.7	200.0	V	298.0	48.6	1.1	24.3	74
1401.500000	50.7	200.0	V	310.0	47.8	2.9	23.3	74
1549.250000	50.6	200.0	V	88.0	46.9	3.7	23.4	74
2049.000000	54.0	200.0	V	124.0	47.2	6.8	20.0	74
2514.250000	61.0	200.0	V	191.0	51.2	9.8	13.0	74
3249.375000	40.1	200.0	V	33.0	42.5	-2.4	33.9	74

Remark: 1. Correction Factor = Antenna factor+ Insertion loss (cable loss + amplifier gain)

Frequency (MHz)	Average (dBuV/m)	Height (cm)	Polarization	Azimuth (deg)	Reading value (dBuV/m)	Correct Factor (dB)	Margin (dB)	Limit (dBuV/m)
1152.750000	38.2	200.0	V	148.0	36.7	1.5	15.8	54
1404.000000	39.0	200.0	V	322.0	36.1	2.9	15.0	54
1509.750000	39.6	200.0	V	310.0	36.1	3.5	14.4	54
1999.750000	43.7	200.0	V	329.0	37.1	6.6	10.3	54
2511.750000	50.1	200.0	V	334.0	40.3	9.8	3.9	54
9327.500000	37.8	200.0	V	0.0	30.0	7.8	16.2	54

Remark: 1. Correction Factor = Antenna factor+ Insertion loss (cable loss + amplifier gain)

## 802.11g CH11

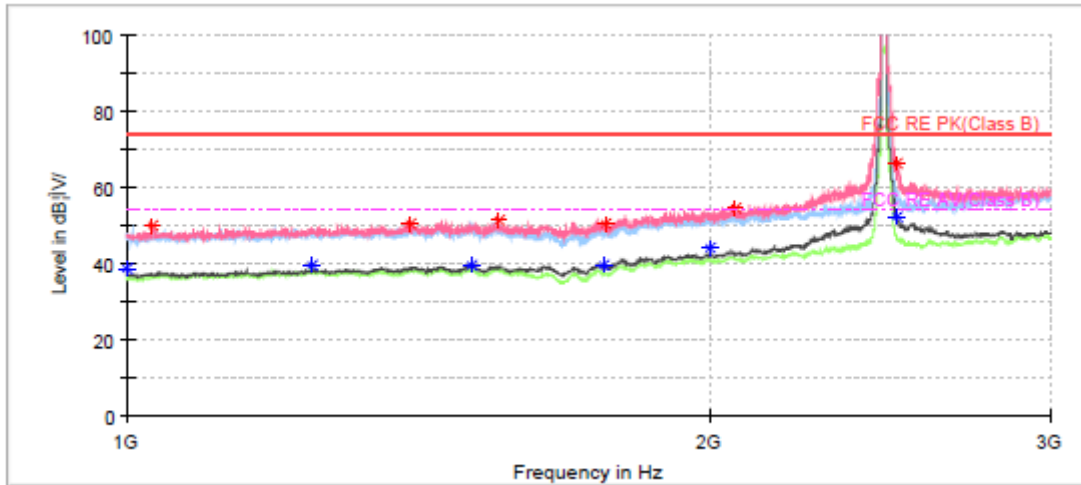

Note: The signal beyond the limit is carrier.

Radiates Emission from 1GHz to 3GHz

RE 3-18GHz PK+AV

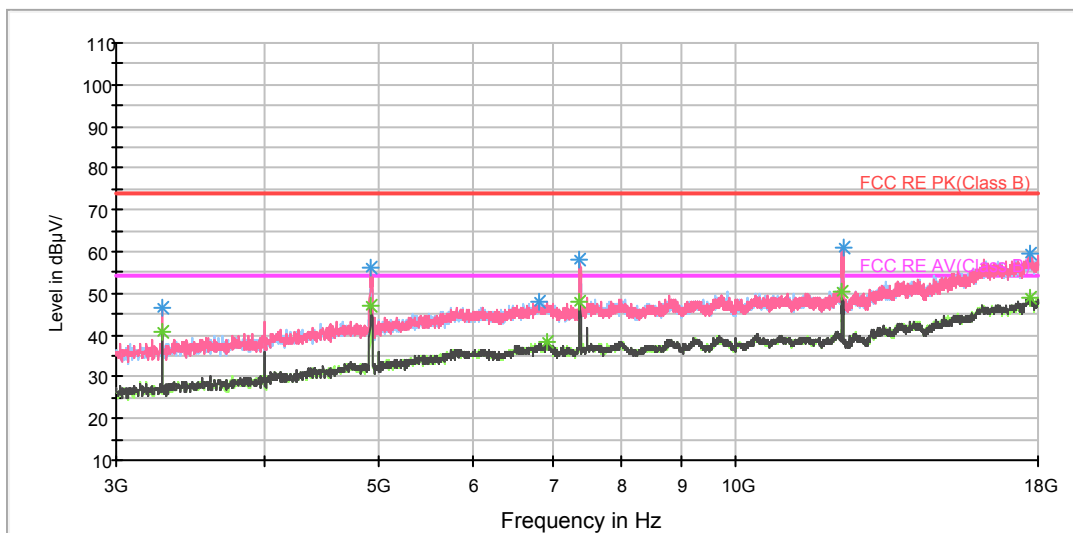

Radiates Emission from 3GHz to 18GHz



Frequency (MHz)	Peak (dBuV/m)	Height (cm)	Polarization	Azimuth (deg)	Reading value (dBuV/m)	Correct Factor (dB)	Margin (dB)	Limit (dBuV/m)
1032.000000	50.0	200.0	V	0.0	49.1	0.9	24.0	74
1400.500000	50.3	200.0	H	6.0	47.4	2.9	23.7	74
1555.500000	51.3	200.0	V	162.0	47.7	3.6	22.7	74
2062.000000	54.4	100.0	V	0.0	47.5	6.9	19.6	74
2498.250000	66.3	200.0	V	341.0	56.4	9.9	7.7	74
3281.250000	46.7	200.0	V	40.0	49.0	-2.3	27.3	74

Remark: 1. Correction Factor = Antenna factor+ Insertion loss (cable loss + amplifier gain)

Frequency (MHz)	Average (dBuV/m)	Height (cm)	Polarization	Azimuth (deg)	Reading value (dBuV/m)	Correct Factor (dB)	Margin (dB)	Limit (dBuV/m)
1000.000000	38.7	200.0	V	347.0	37.9	0.8	15.3	54
1245.250000	39.4	100.0	H	225.0	37.4	2.0	14.6	54
1505.000000	39.6	200.0	V	0.0	36.2	3.4	14.4	54
2000.000000	44.3	200.0	V	0.0	37.7	6.6	9.7	54
2498.250000	52.4	200.0	V	341.0	42.5	9.9	1.6	54
3281.250000	40.8	200.0	V	40.0	43.1	-2.3	13.2	54

Remark: 1. Correction Factor = Antenna factor+ Insertion loss (cable loss + amplifier gain)

**MIMO**

**802.11n (HT20) CH1**

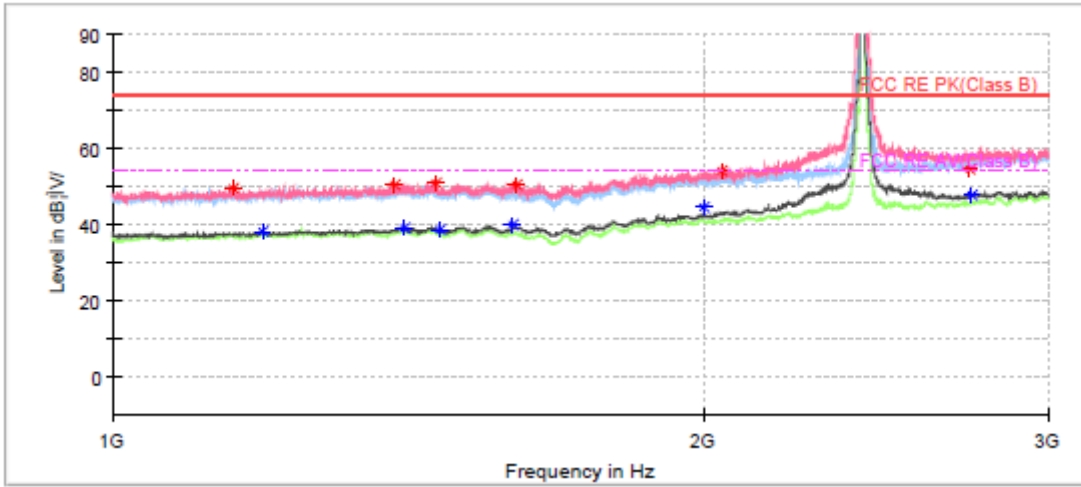

Note: The signal beyond the limit is carrier.

Radiates Emission from 1GHz to 3GHz

RE 3-18GHz PK+AV

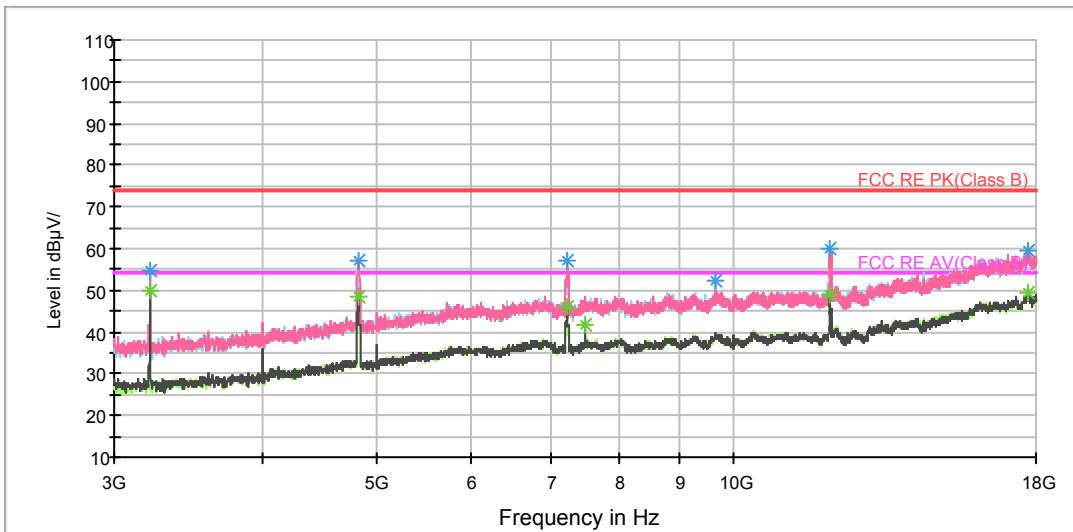

Radiates Emission from 3GHz to 18GHz



Frequency (MHz)	Peak (dBuV/m)	Height (cm)	Polarization	Azimuth (deg)	Reading value (dBuV/m)	Correct Factor (dB)	Margin (dB)	Limit (dBuV/m)
1150.500000	49.7	100.0	V	183.0	48.2	1.5	24.3	74
1391.750000	50.6	100.0	V	0.0	47.6	3.0	23.4	74
1460.000000	51.0	100.0	V	227.0	47.9	3.1	23.0	74
2045.750000	54.3	100.0	V	359.0	47.5	6.8	19.7	74
2501.250000	60.4	200.0	V	164.0	50.6	9.8	13.6	74
3215.625000	54.9	200.0	V	25.0	57.3	-2.4	19.1	74

Remark: 1. Correction Factor = Antenna factor+ Insertion loss (cable loss + amplifier gain)

Frequency (MHz)	Average (dBuV/m)	Height (cm)	Polarization	Azimuth (deg)	Reading value (dBuV/m)	Correct Factor (dB)	Margin (dB)	Limit (dBuV/m)
1191.750000	38.2	200.0	V	236.0	36.4	1.8	15.8	54
1407.750000	39.1	100.0	V	270.0	36.2	2.9	14.9	54
1599.500000	40.1	200.0	V	290.0	36.5	3.6	13.9	54
2000.000000	44.5	100.0	V	311.0	37.9	6.6	9.5	54
2500.250000	50.1	200.0	V	0.0	40.3	9.8	3.9	54
3215.625000	49.9	200.0	V	25.0	52.3	-2.4	4.1	54

Remark: 1. Correction Factor = Antenna factor+ Insertion loss (cable loss + amplifier gain)

802.11n (HT20) CH6

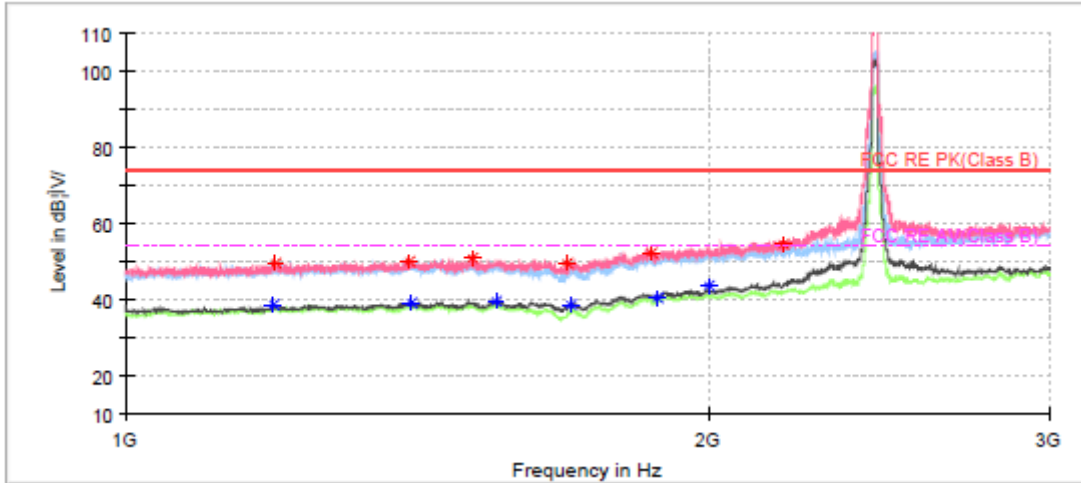

Note: The signal beyond the limit is carrier.

Radiates Emission from 1GHz to 3GHz

RE 3-18GHz PK+AV

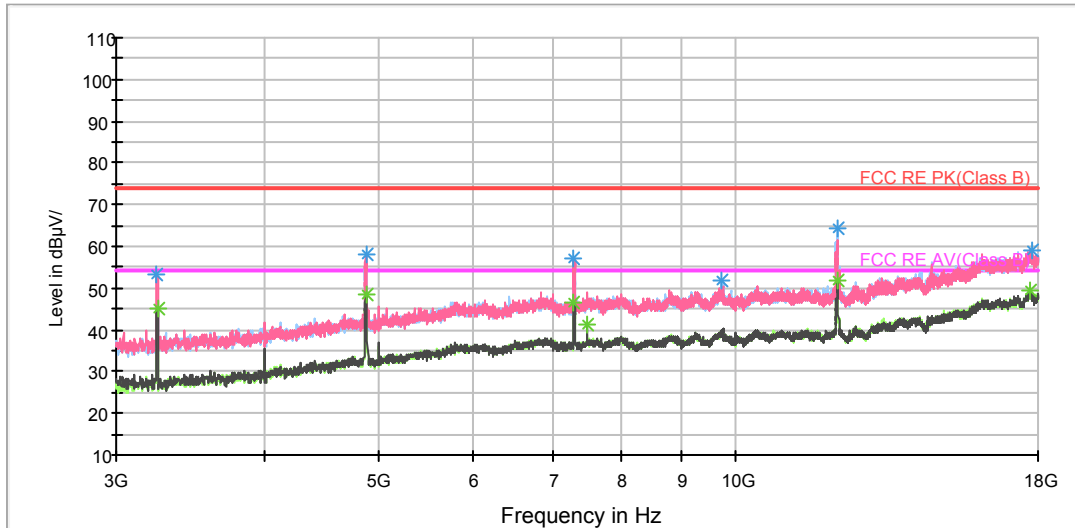

Radiates Emission from 3GHz to 18GHz





Frequency (MHz)	Peak (dBuV/m)	Height (cm)	Polarization	Azimuth (deg)	Reading value (dBuV/m)	Correct Factor (dB)	Margin (dB)	Limit (dBuV/m)
1195.250000	49.5	100.0	V	162.0	47.7	1.8	24.5	74
1402.750000	50.1	100.0	H	46.0	47.2	2.9	23.9	74
1509.000000	51.1	200.0	V	264.0	47.6	3.5	22.9	74
2053.750000	54.7	200.0	V	355.0	47.9	6.8	19.3	74
2502.750000	60.9	200.0	V	337.0	51.1	9.8	13.1	74
3247.500000	53.1	200.0	V	22.0	55.5	-2.4	20.9	74

Remark: 1. Correction Factor = Antenna factor+ Insertion loss (cable loss + amplifier gain)

Frequency (MHz)	Average (dBuV/m)	Height (cm)	Polarization	Azimuth (deg)	Reading value (dBuV/m)	Correct Factor (dB)	Margin (dB)	Limit (dBuV/m)
1192.250000	38.5	200.0	V	247.0	36.7	1.8	15.5	54
1403.500000	39.0	200.0	V	97.0	36.1	2.9	15.0	54
1554.500000	39.5	200.0	V	139.0	35.9	3.6	14.5	54
1999.750000	43.8	100.0	V	0.0	37.2	6.6	10.2	54
2510.750000	50.5	200.0	V	337.0	40.7	9.8	3.5	54
3249.375000	45.3	200.0	V	22.0	47.7	-2.4	8.7	54

Remark: 1. Correction Factor = Antenna factor+ Insertion loss (cable loss + amplifier gain)

802.11n (HT20) CH11

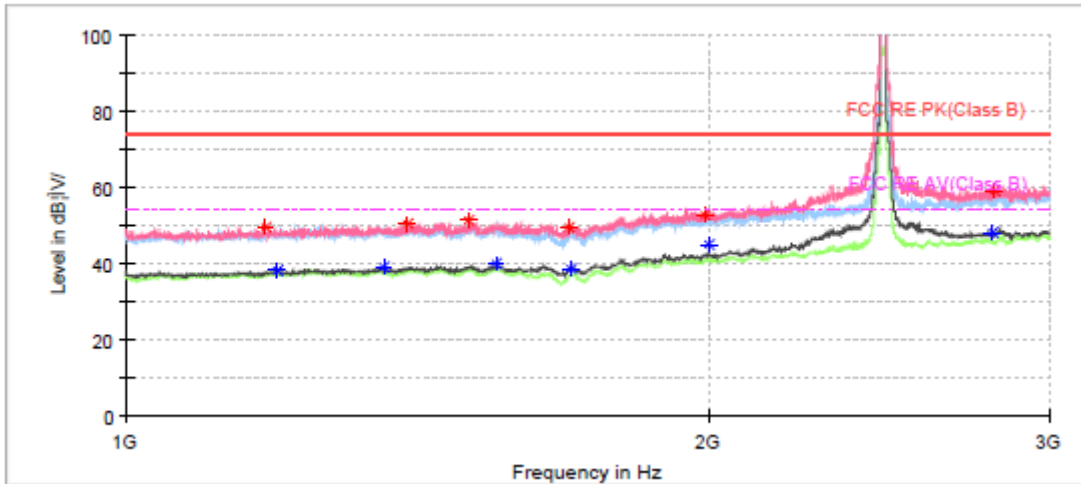

Note: The signal beyond the limit is carrier.

Radiates Emission from 1GHz to 3GHz

RE 3-18GHz PK+AV

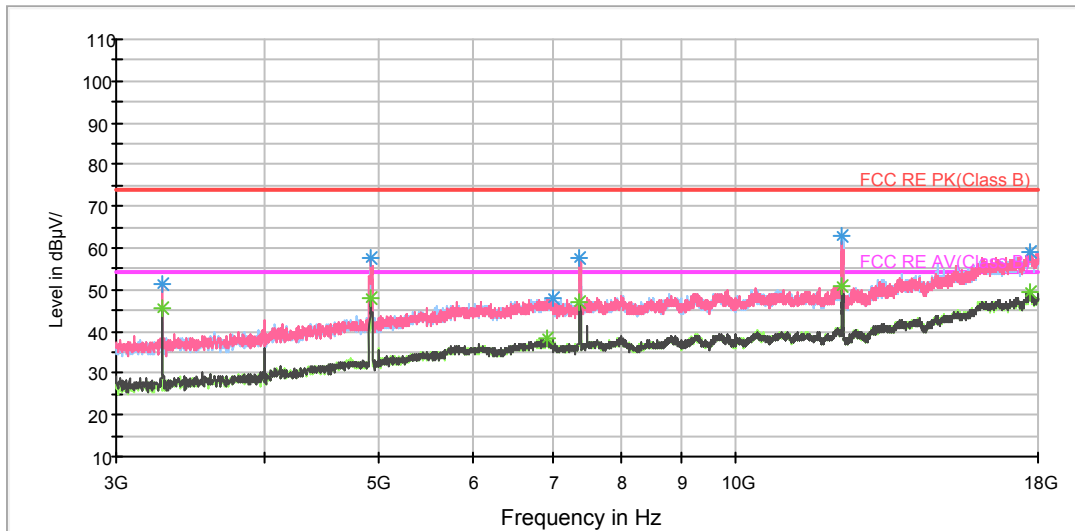

Radiates Emission from 3GHz to 18GHz



Frequency (MHz)	Peak (dBuV/m)	Height (cm)	Polarization	Azimuth (deg)	Reading value (dBuV/m)	Correct Factor (dB)	Margin (dB)	Limit (dBuV/m)
1181.750000	49.7	200.0	V	237.0	47.7	2.0	24.3	74
1398.500000	50.5	100.0	V	186.0	47.6	2.9	23.5	74
1503.250000	51.2	200.0	V	7.0	47.8	3.4	22.8	74
2062.000000	54.5	200.0	V	261.0	47.6	6.9	19.5	74
2501.500000	65.4	100.0	V	277.0	55.6	9.8	8.6	74
3281.250000	51.2	200.0	V	28.0	53.5	-2.3	22.8	74

Remark: 1. Correction Factor = Antenna factor+ Insertion loss (cable loss + amplifier gain)

Frequency (MHz)	Average (dBuV/m)	Height (cm)	Polarization	Azimuth (deg)	Reading value (dBuV/m)	Correct Factor (dB)	Margin (dB)	Limit (dBuV/m)
1196.750000	38.3	200.0	V	37.0	36.5	1.8	15.7	54
1358.500000	39.2	100.0	V	289.0	36.6	2.6	14.8	54
1551.750000	39.8	100.0	V	0.0	36.1	3.7	14.2	54
2000.000000	44.8	100.0	V	338.0	38.2	6.6	9.2	54
2500.250000	52.4	200.0	V	343.0	42.6	9.8	1.6	54
3281.250000	45.5	200.0	V	28.0	47.8	-2.3	8.5	54

Remark: 1. Correction Factor = Antenna factor+ Insertion loss (cable loss + amplifier gain)

802.11n (HT40) CH3

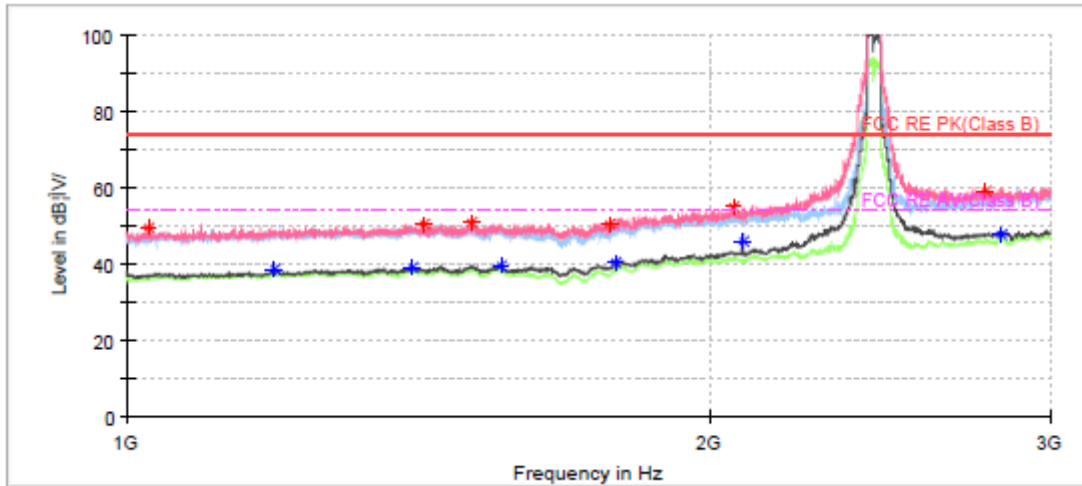

Note: The signal beyond the limit is carrier.

Radiates Emission from 1GHz to 3GHz

RE 3-18GHz PK+AV

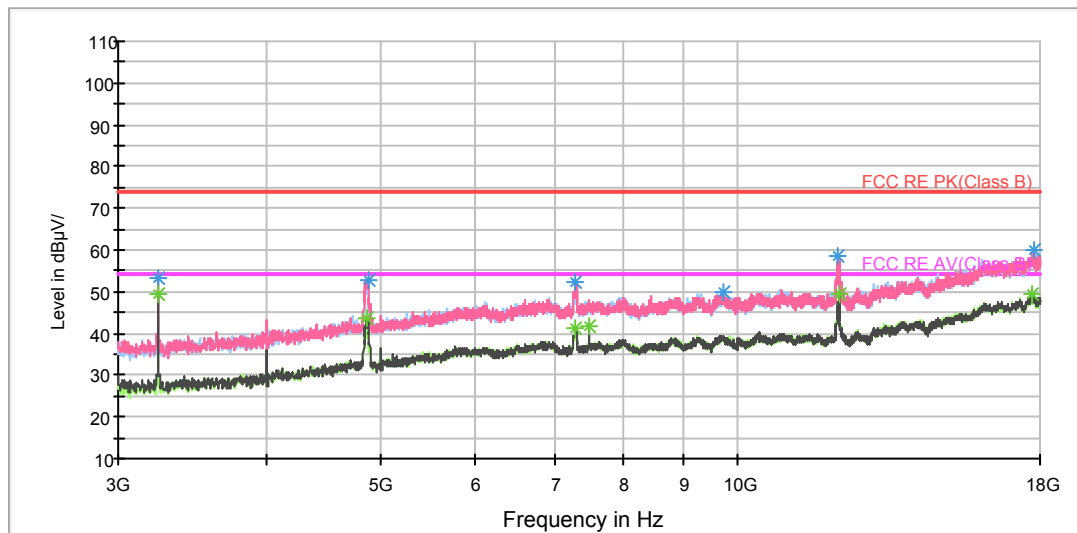

Radiates Emission from 3GHz to 18GHz



Frequency (MHz)	Peak (dBuV/m)	Height (cm)	Polarization	Azimuth (deg)	Reading value (dBuV/m)	Correct Factor (dB)	Margin (dB)	Limit (dBuV/m)
1025.000000	49.6	100.0	V	334.0	48.7	0.9	24.4	74
1425.250000	50.3	100.0	V	0.0	47.2	3.1	23.7	74
1506.250000	50.8	200.0	V	131.0	47.4	3.4	23.2	74
2056.750000	55.2	100.0	V	352.0	48.4	6.8	18.8	74
2499.750000	66.5	200.0	V	305.0	56.7	9.8	7.5	74
3241.875000	53.1	200.0	V	30.0	55.5	-2.4	20.9	74

Remark: 1. Correction Factor = Antenna factor+ Insertion loss (cable loss + amplifier gain)

Frequency (MHz)	Average (dBuV/m)	Height (cm)	Polarization	Azimuth (deg)	Reading value (dBuV/m)	Correct Factor (dB)	Margin (dB)	Limit (dBuV/m)
1191.250000	38.6	200.0	V	167.0	36.8	1.8	15.4	54
1403.500000	39.2	100.0	V	352.0	36.3	2.9	14.8	54
1562.250000	39.7	200.0	V	76.0	36.3	3.4	14.3	54
2080.000000	48.3	200.0	V	178.0	41.3	7.0	5.7	54
2501.750000	53.5	200.0	V	337.0	43.7	9.8	0.5	54
3241.875000	49.4	200.0	V	30.0	51.8	-2.4	4.6	54

Remark: 1. Correction Factor = Antenna factor+ Insertion loss (cable loss + amplifier gain)

802.11n (HT40) CH6

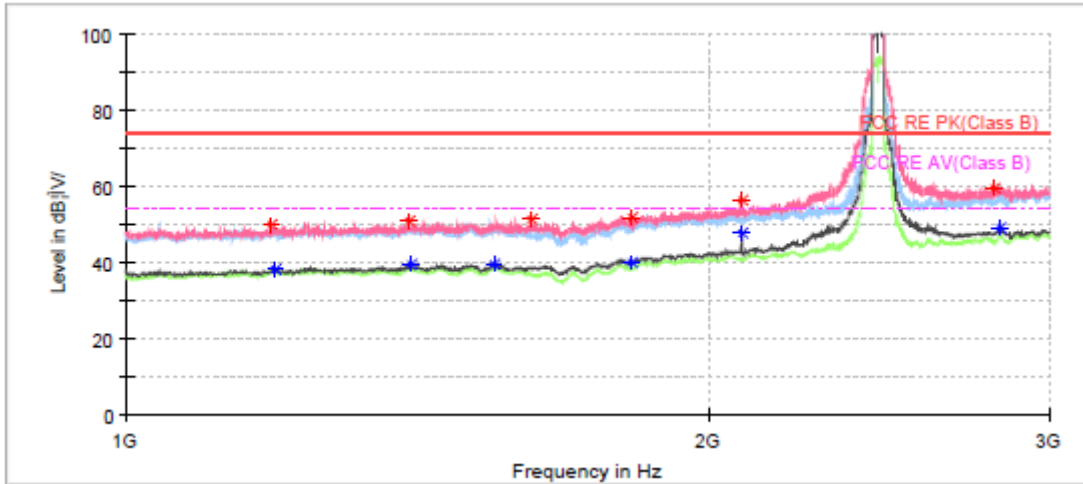

Note: The signal beyond the limit is carrier.

Radiates Emission from 1GHz to 3GHz

RE 3-18GHz PK+AV

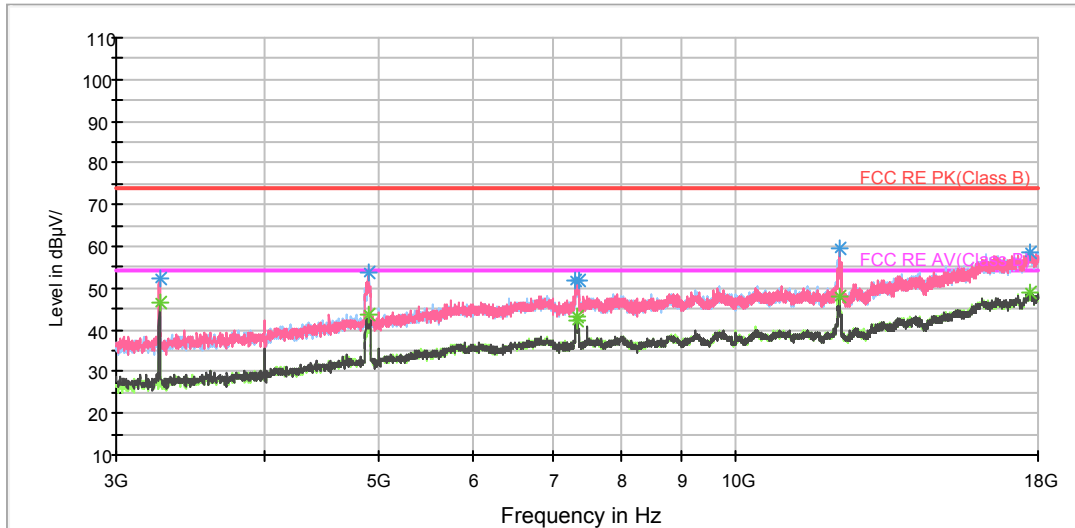

Radiates Emission from 3GHz to 18GHz



Frequency (MHz)	Peak (dBuV/m)	Height (cm)	Polarization	Azimuth (deg)	Reading value (dBuV/m)	Correct Factor (dB)	Margin (dB)	Limit (dBuV/m)
1189.000000	49.9	200.0	V	292.0	48.1	1.8	24.1	74
1399.750000	50.8	200.0	V	0.0	47.9	2.9	23.2	74
1619.750000	51.4	200.0	V	243.0	46.2	5.2	22.6	74
2080.000000	56.2	200.0	V	171.0	49.2	7.0	17.8	74
3262.500000	52.3	200.0	V	25.0	54.6	-2.3	21.7	74

Remark: 1. Correction Factor = Antenna factor+ Insertion loss (cable loss + amplifier gain)

Frequency (MHz)	Average (dBuV/m)	Height (cm)	Polarization	Azimuth (deg)	Reading value (dBuV/m)	Correct Factor (dB)	Margin (dB)	Limit (dBuV/m)
1194.750000	38.2	200.0	V	231.0	36.4	1.8	15.8	54
1404.500000	39.4	100.0	V	0.0	36.5	2.9	14.6	54
1550.000000	39.5	200.0	V	158.0	35.8	3.7	14.5	54
2080.000000	47.6	200.0	V	171.0	40.6	7.0	6.4	54
3262.500000	46.3	200.0	V	25.0	48.6	-2.3	7.7	54

Remark: 1. Correction Factor = Antenna factor+ Insertion loss (cable loss + amplifier gain)

802.11n (HT40) CH9

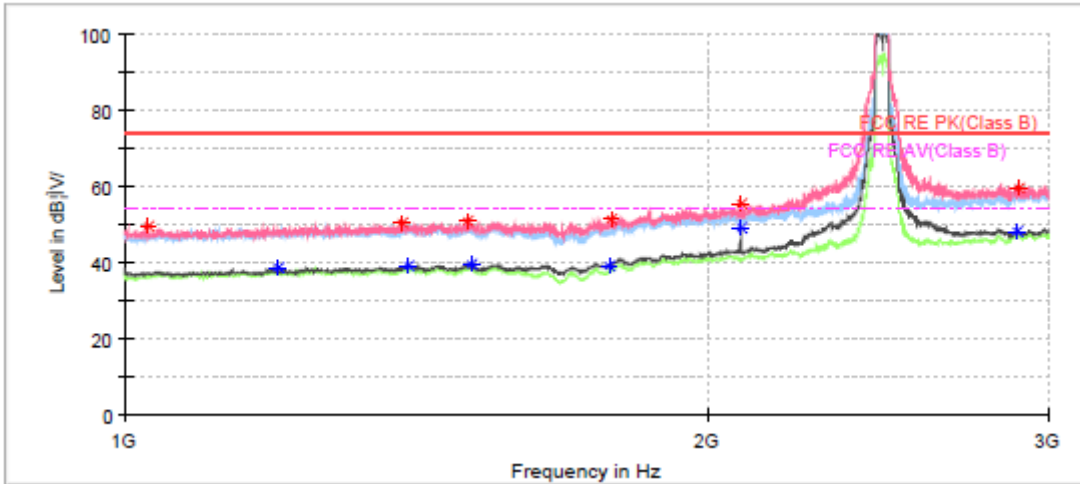

Note: The signal beyond the limit is carrier.

Radiates Emission from 1GHz to 3GHz

RE 3-18GHz PK+AV

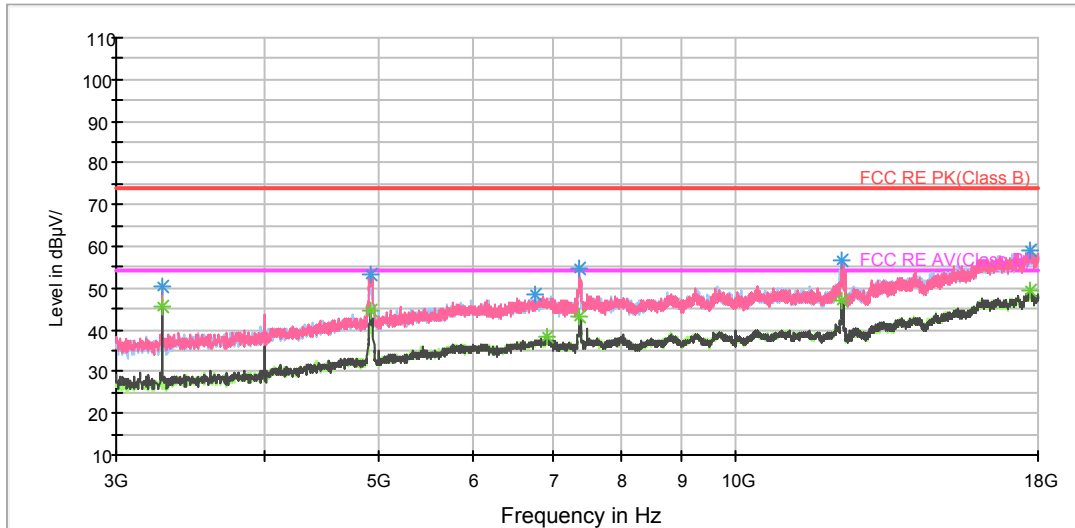

Radiates Emission from 3GHz to 18GHz





Frequency (MHz)	Peak (dBuV/m)	Height (cm)	Polarization	Azimuth (deg)	Reading value (dBuV/m)	Correct Factor (dB)	Margin (dB)	Limit (dBuV/m)
1029.250000	49.7	200.0	V	0.0	48.8	0.9	24.3	74
1390.250000	50.4	200.0	V	0.0	47.4	3.0	23.6	74
1502.750000	50.9	100.0	V	43.0	47.5	3.4	23.1	74
2079.750000	55.4	200.0	V	343.0	48.4	7.0	18.6	74
3281.250000	50.4	200.0	V	56.0	52.7	-2.3	23.6	74

Remark: 1. Correction Factor = Antenna factor+ Insertion loss (cable loss + amplifier gain)

Frequency (MHz)	Average (dBuV/m)	Height (cm)	Polarization	Azimuth (deg)	Reading value (dBuV/m)	Correct Factor (dB)	Margin (dB)	Limit (dBuV/m)
1200.000000	38.6	200.0	V	206.0	36.8	1.8	15.4	54
1402.000000	39.2	100.0	V	6.0	36.3	2.9	14.8	54
1509.000000	39.7	200.0	V	283.0	36.2	3.5	14.3	54
2080.000000	48.9	200.0	V	193.0	41.9	7.0	5.1	54
3281.250000	45.5	200.0	V	56.0	47.8	-2.3	8.5	54

Remark: 1. Correction Factor = Antenna factor+ Insertion loss (cable loss + amplifier gain)

### 5.7. Conducted Emission

#### Ambient condition

Temperature	Relative humidity	Pressure
23°C ~25°C	45%~50%	101.5kPa

#### Methods of Measurement

The EUT is placed on a non-metallic table of 80cm height above the horizontal metal reference ground plane. During the test, the EUT was operating in its typical mode. The test method is according to ANSI C63.10-2013. Connect the AC power line of the EUT to the L.I.S.N. Use EMI receiver to detect the average and Quasi-peak value. RBW is set to 9 kHz, VBW is set to 30kHz. The measurement result should include both L line and N line.

The test is in transmitting mode.

#### Test Setup

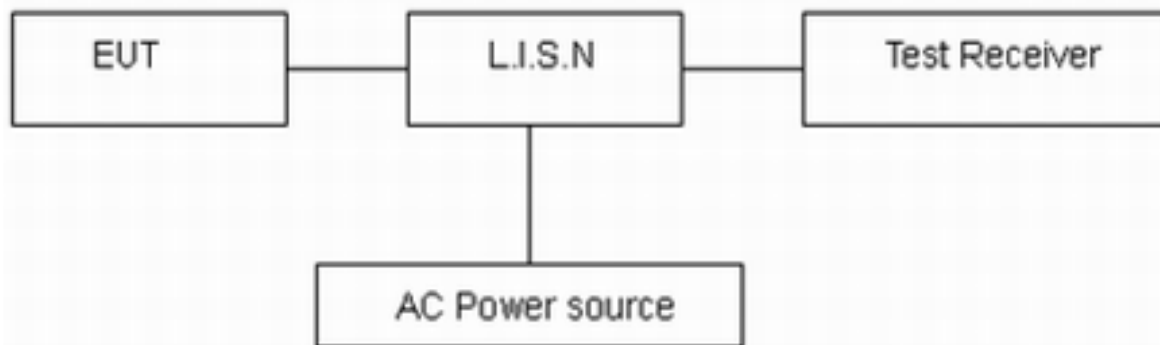

Note: AC Power source is used to change the voltage 120V/60Hz.

#### Limits

Frequency (MHz)	Conducted Limits(dBμV)	
	Quasi-peak	Average
0.15 - 0.5	66 to 56 *	56 to 46*
0.5 - 5	56	46
5 - 30	60	50

\*: Decreases with the logarithm of the frequency.

#### Measurement Uncertainty

The assessed measurement uncertainty to ensure 95% confidence level for the normal distribution is with the coverage factor  $k = 1.96$ ,  $U = 2.69$  dB.



**Test Results:**

Following plots, Blue trace uses the peak detection and Green trace uses the average detection. During the test, the Conducted Emission was performed in all modes (WIFI 2.4G) with all channels, 802.11b, Channel 11 are selected as the worst condition. The test data of the worst-case condition was recorded in this report.

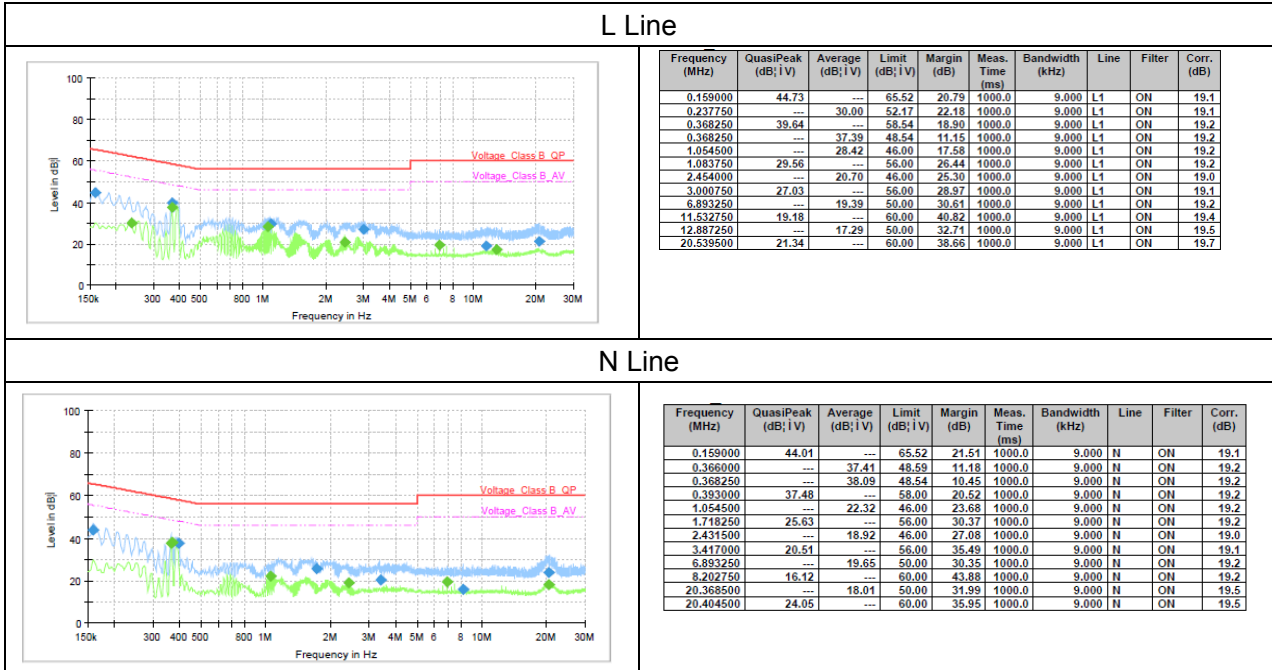



## 6. Main Test Instruments

Name	Manufacturer	Type	Serial Number	Calibration Date	Expiration Date
Spectrum Analyzer	R&S	FSV30	100815	2017-12-17	2018-12-16
EMI Test Receiver	R&S	ESCI	100948	2018-05-20	2019-05-19
Loop Antenna	SCHWARZBECK	FMZB1519	1519-047	2017-09-26	2019-09-25
TRILOG Broadband Antenna	Schwarzbeck	VULB 9163	9163-201	2017-11-18	2019-11-17
Double Ridged Waveguide Horn Antenna	R&S	HF907	100126	2018-07-07	2020-07-06
Standard Gain Horn	ETS-Lindgren	3160-09	00102643	2018-06-20	2020-06-19
EMI Test Receiver	R&S	ESR	101667	2018-05-20	2019-05-19
LISN	R&S	ENV216	101171	2016-12-16	2019-12-15
Spectrum Analyzer	Agilent	N9010A	MY47191109	2018-05-20	2019-05-19
Power Meter	R&S	NRP	104306	2018-05-20	2019-05-19
Power Sensor	R&S	NRP-Z21	104799	2018-05-20	2019-05-19
RF Cable	Agilent	SMA 15cm	0001	/	/
Software	R&S	EMC32	9.26.0	/	/

\*\*\*\*\*END OF REPORT \*\*\*\*\*

## ANNEX A: EUT Appearance and Test Setup

### A.1 EUT Appearance



Front Side



Back Side

a: EUT



Adapter 1



Adapter 2



Adapter 3





Adapter 7

b: Adapter

**Picture 1 EUT and Accessory**



## A.2 Test Setup



30MHz-1GHz

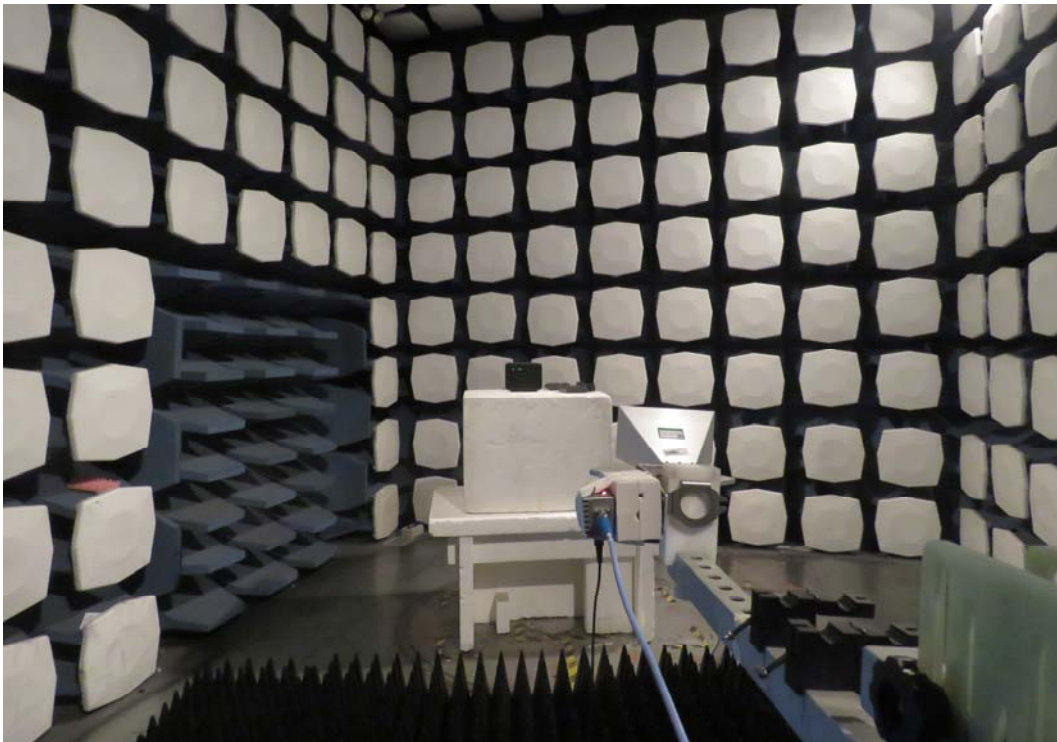

Above 1GHz

**Picture 2 Radiated Emission Test Setup**



**Picture 3 Conducted Emission Test Setup**