

PSD 802.11ax(HE40) 5755MHz Ant1

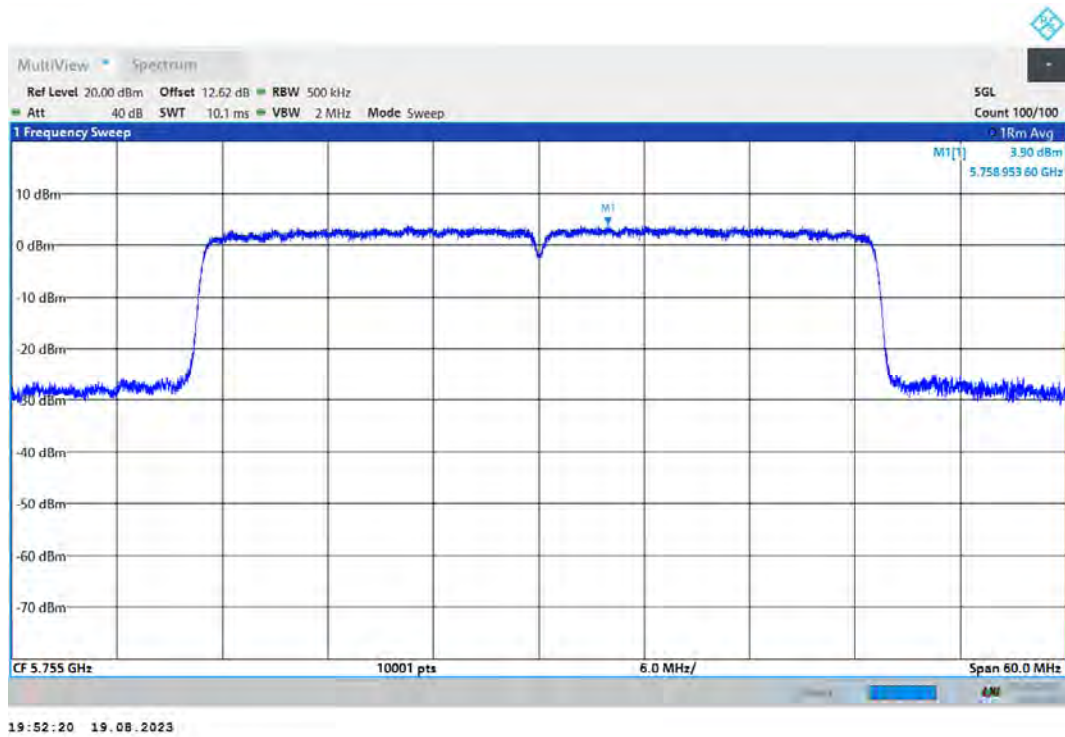

PSD 802.11ax(HE40) 5755MHz Ant2

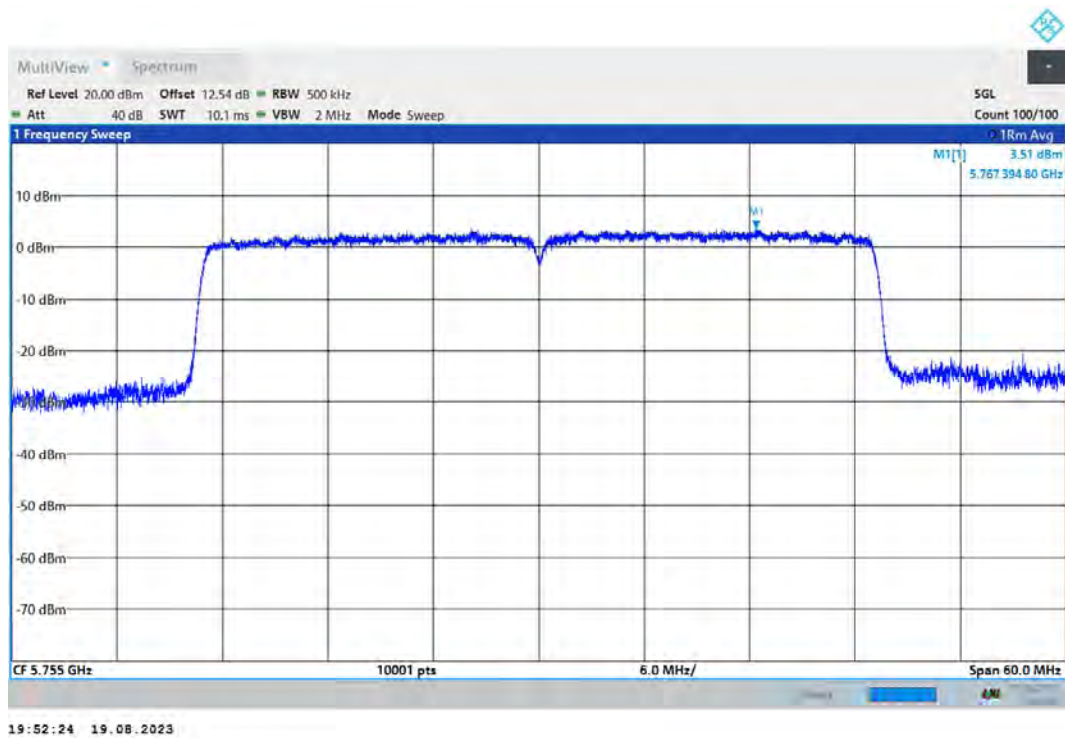

PSD 802.11ax(HE40) 5795MHz Ant1

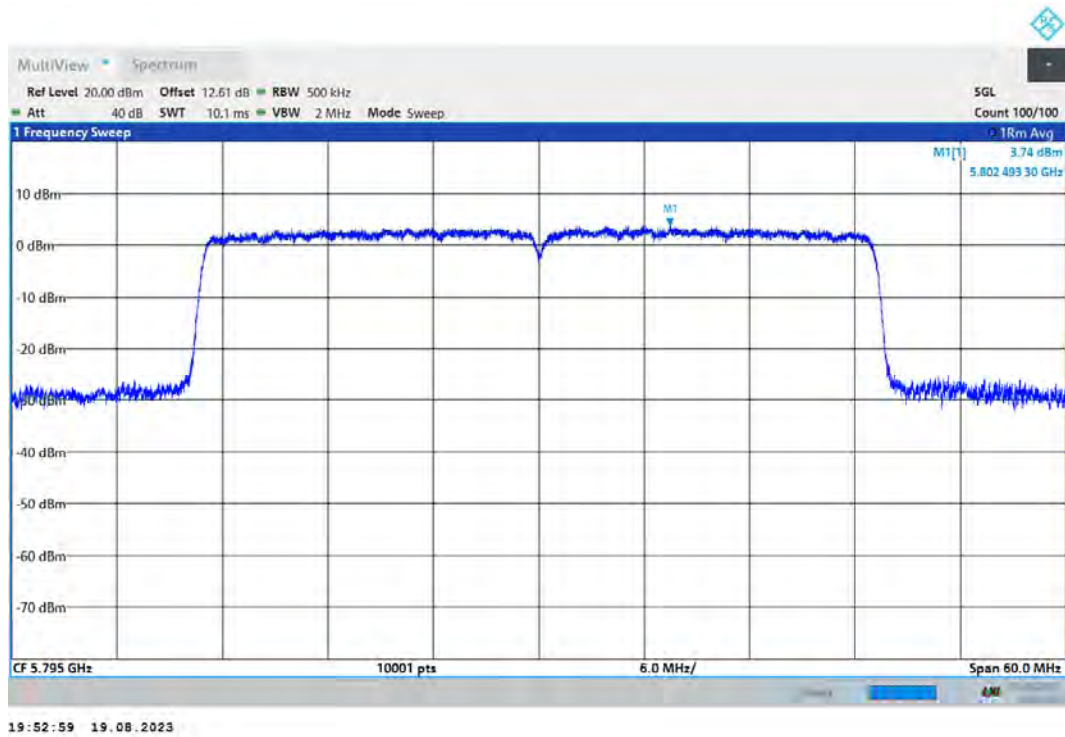

PSD 802.11ax(HE40) 5795MHz Ant2

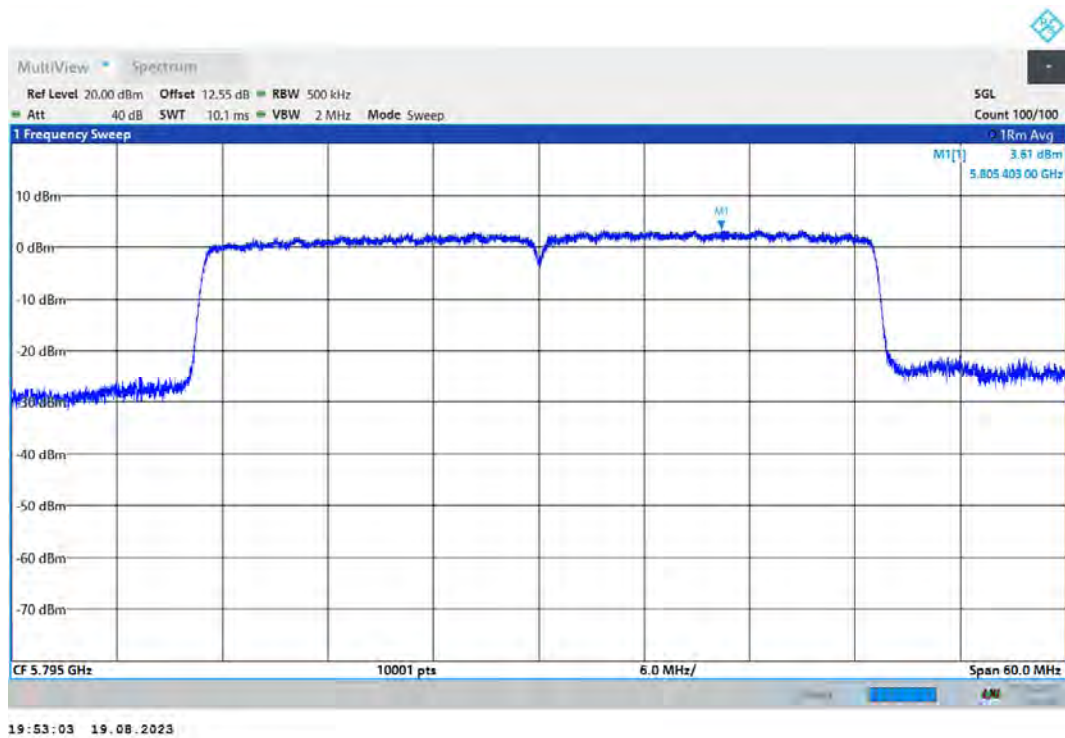

PSD 802.11ax(HE80) 5690MHz Ant1

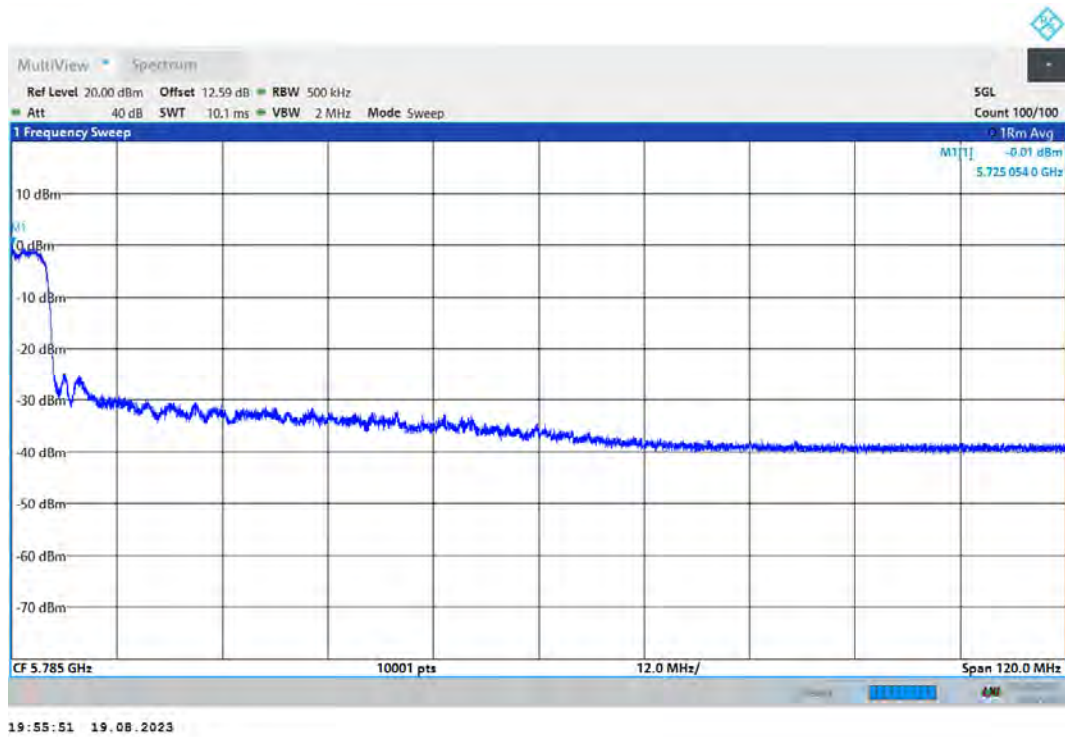

PSD 802.11ax(HE80) 5690MHz Ant2

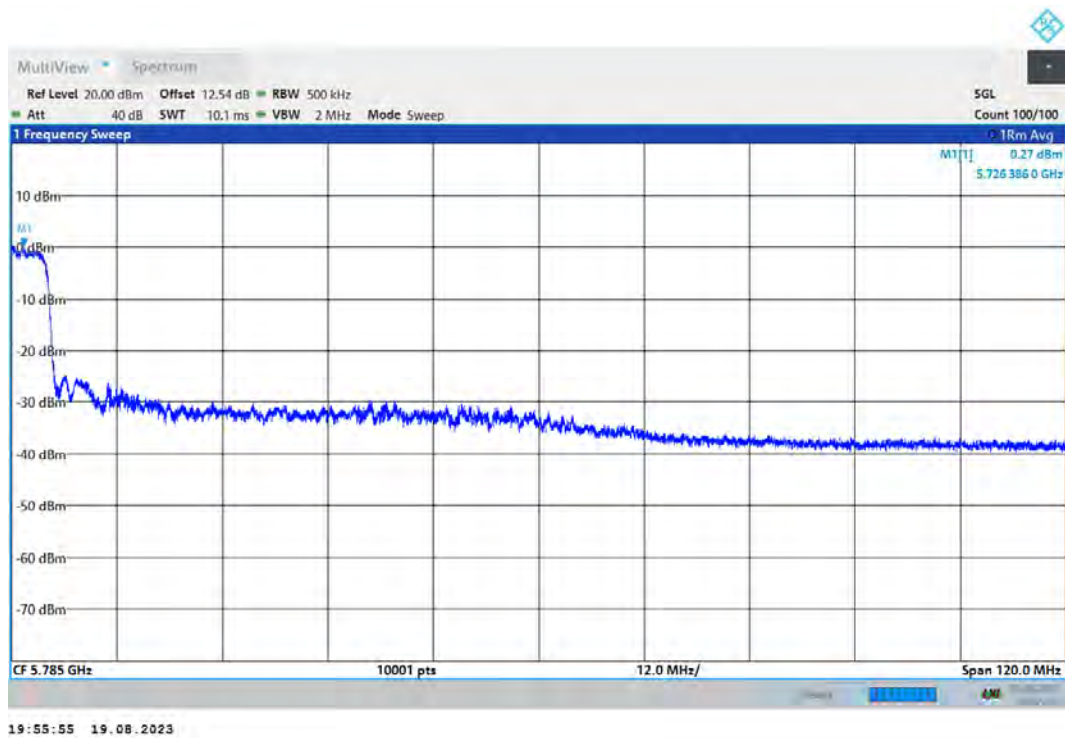

PSD 802.11ax(HE80) 5775MHz Ant1

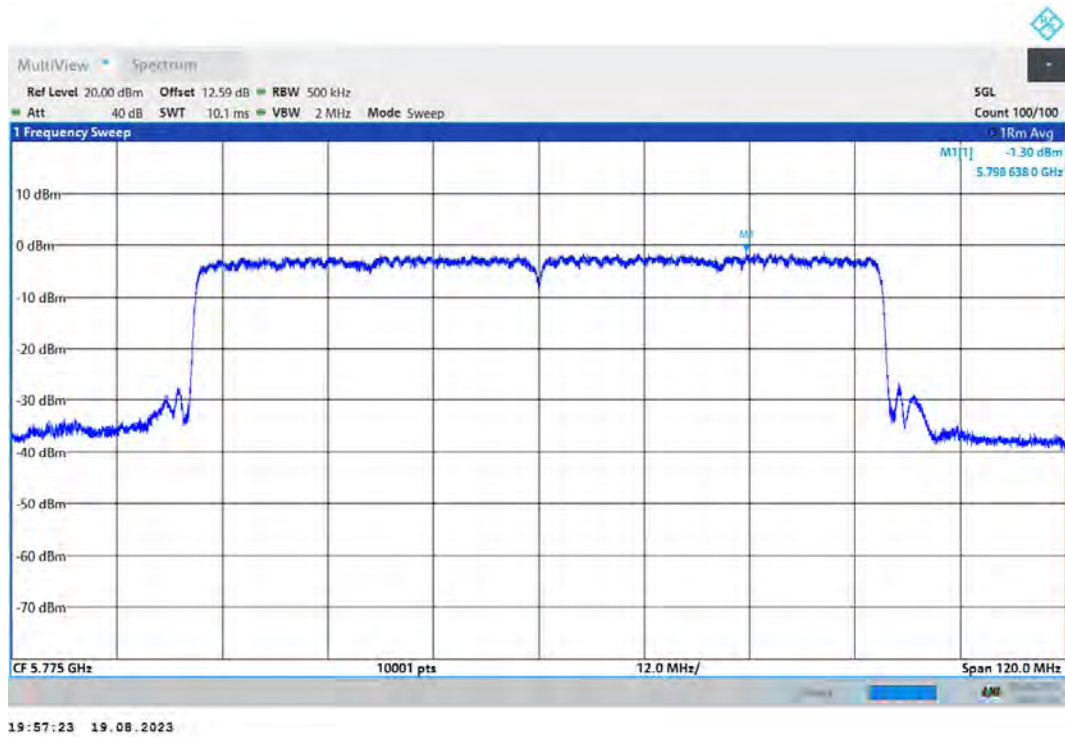

PSD 802.11ax(HE80) 5775MHz Ant2

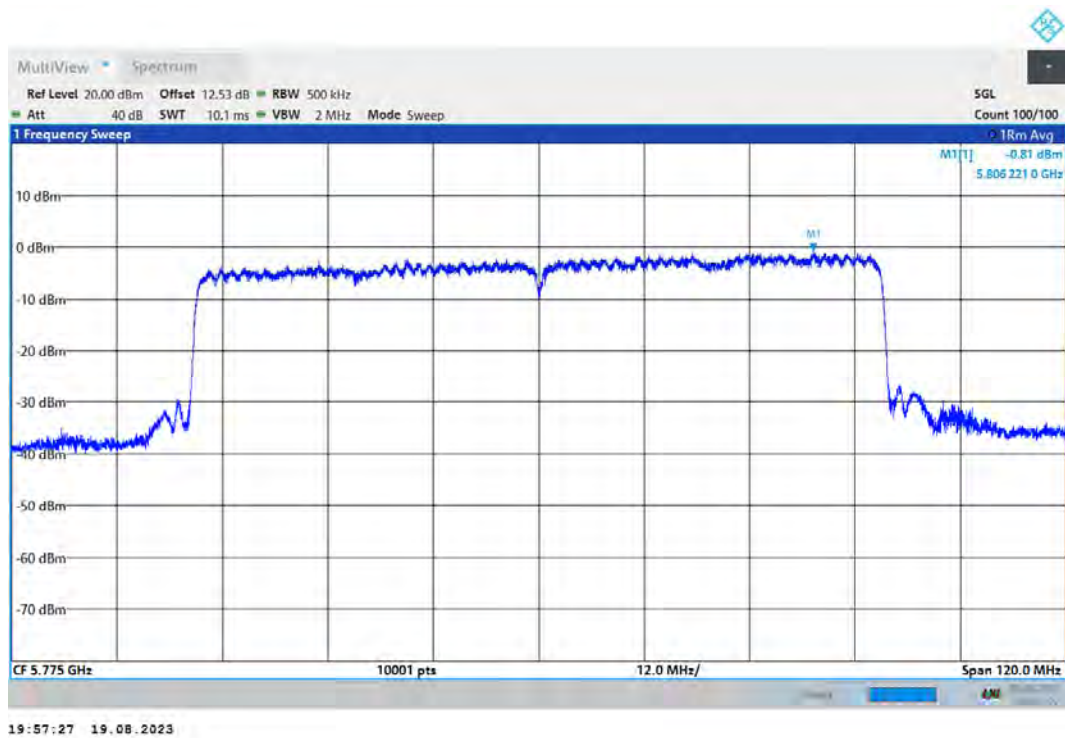

PSD 802.11n(HT20) 5720MHz Ant1

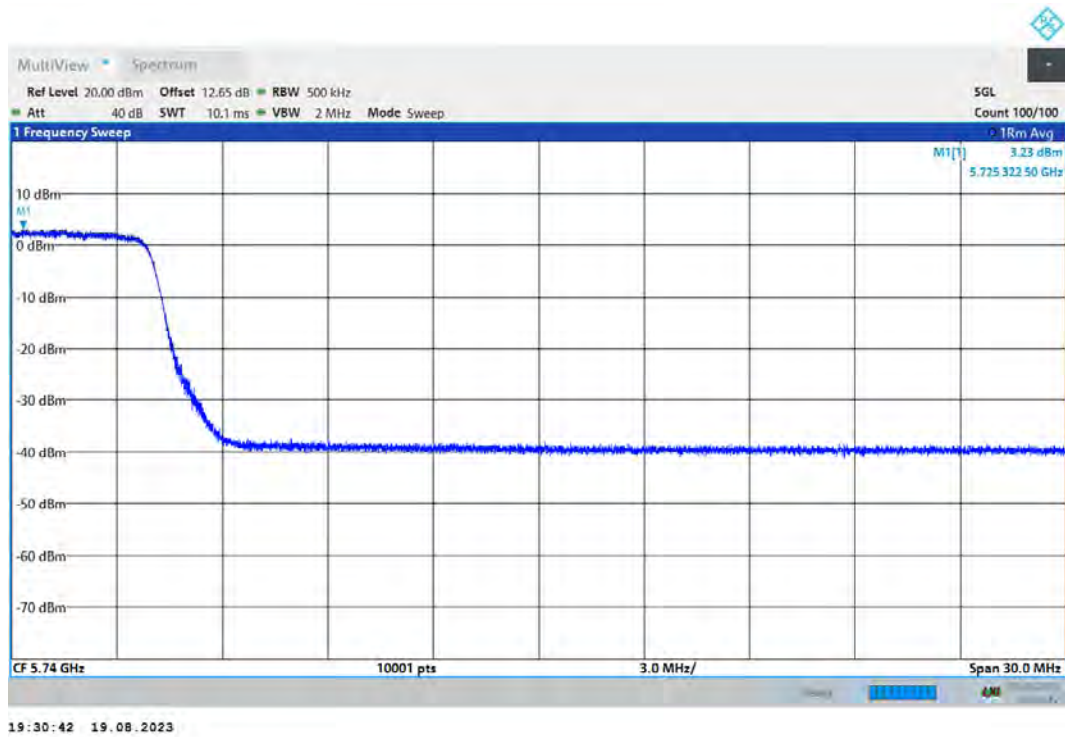

PSD 802.11n(HT20) 5720MHz Ant2

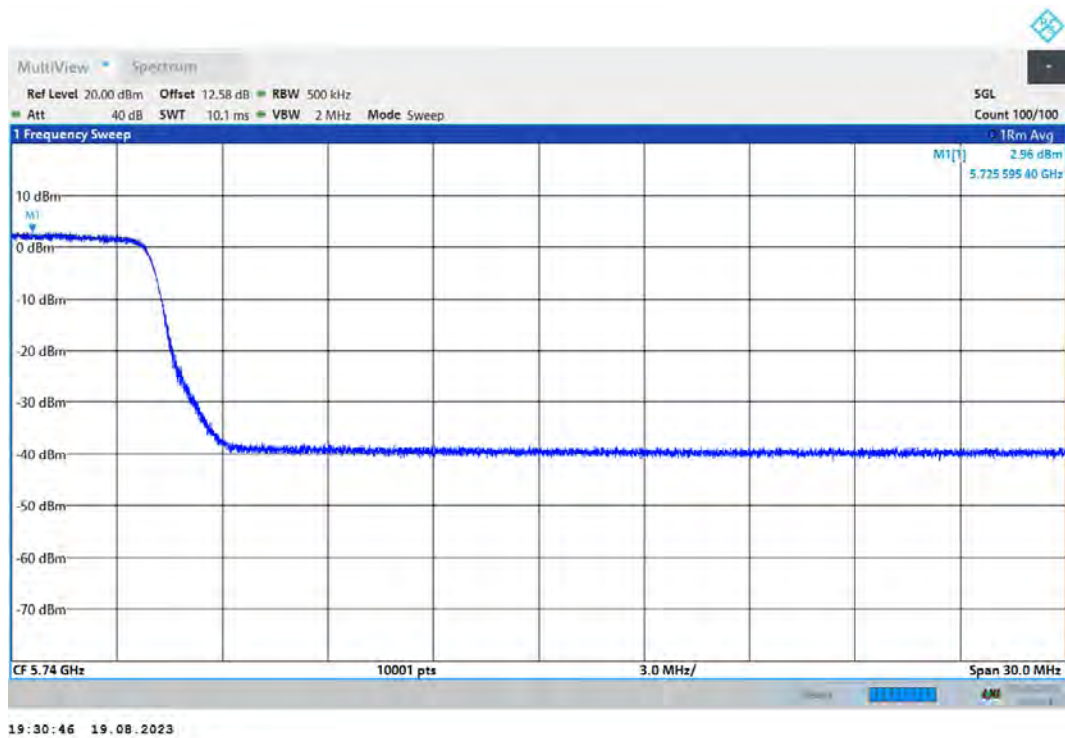

PSD 802.11n(HT20) 5745MHz Ant1

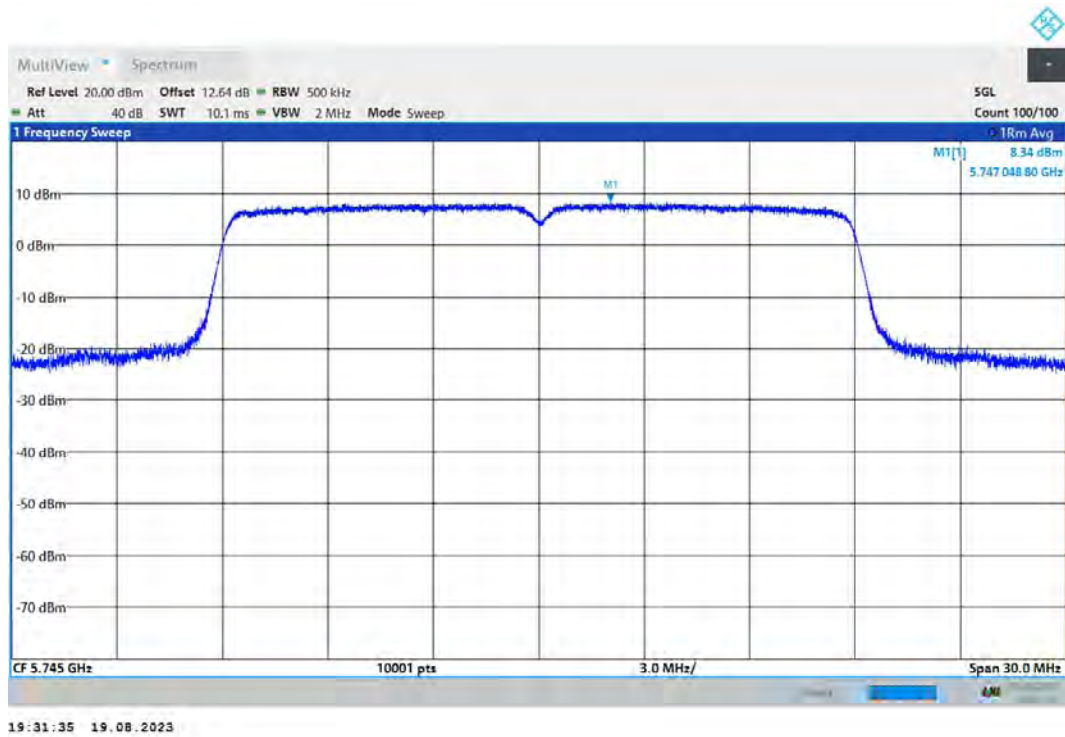

PSD 802.11n(HT20) 5745MHz Ant2

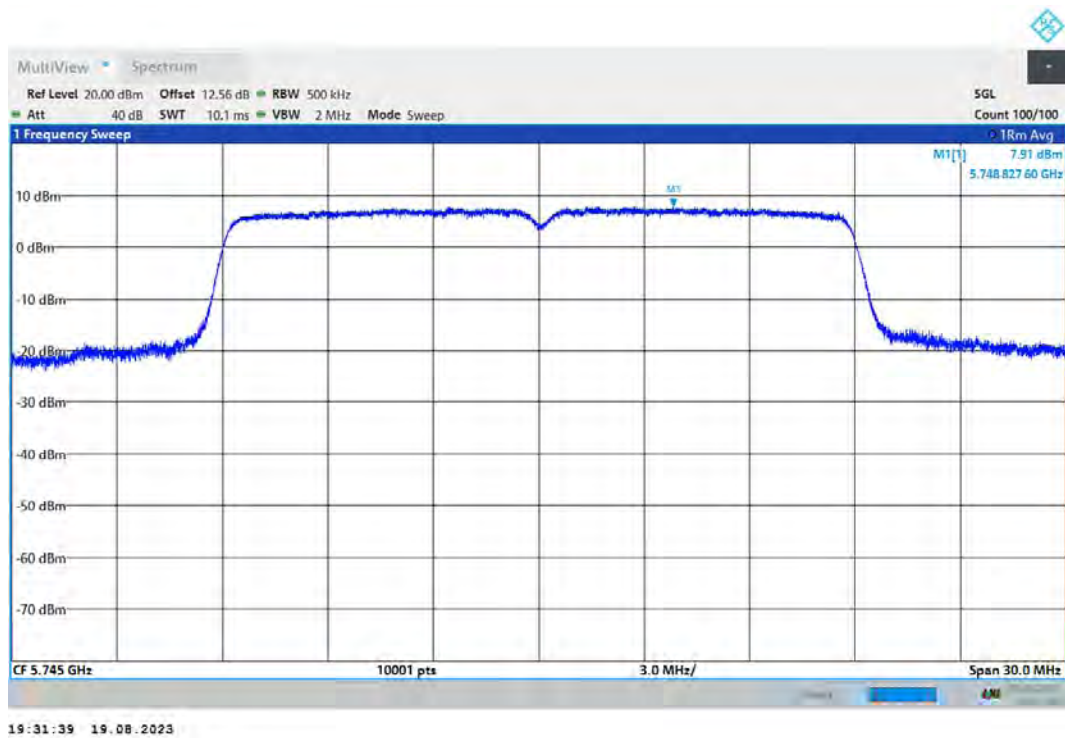

PSD 802.11n(HT20) 5785MHz Ant1

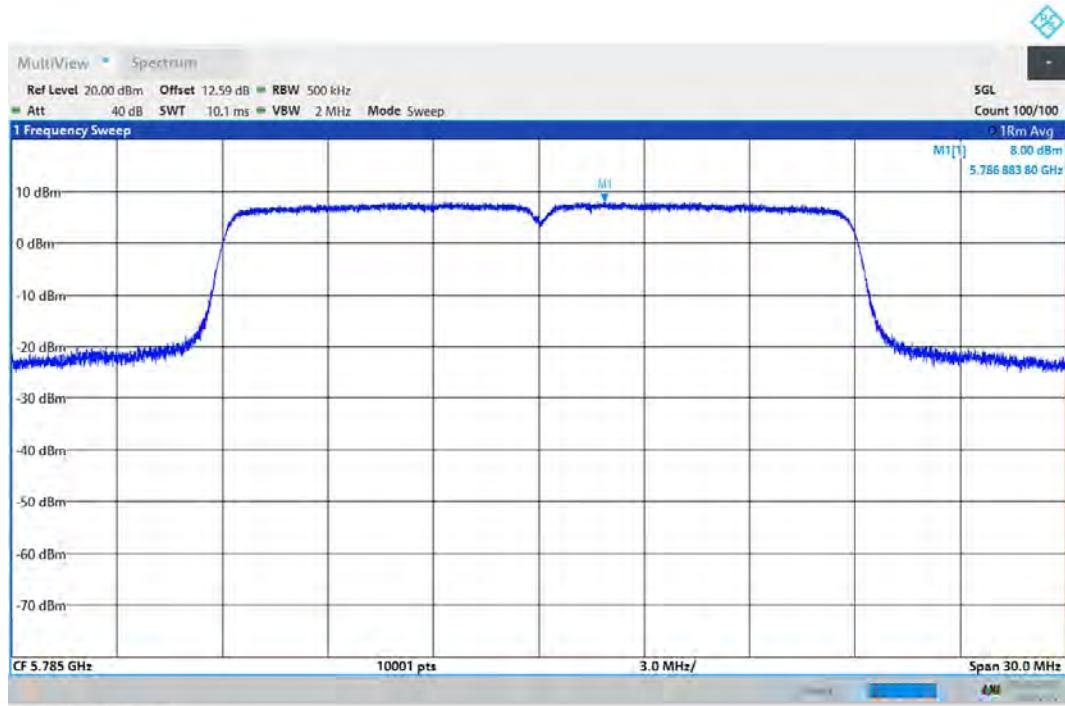

19:32:27 19.08.2023

PSD 802.11n(HT20) 5785MHz Ant2

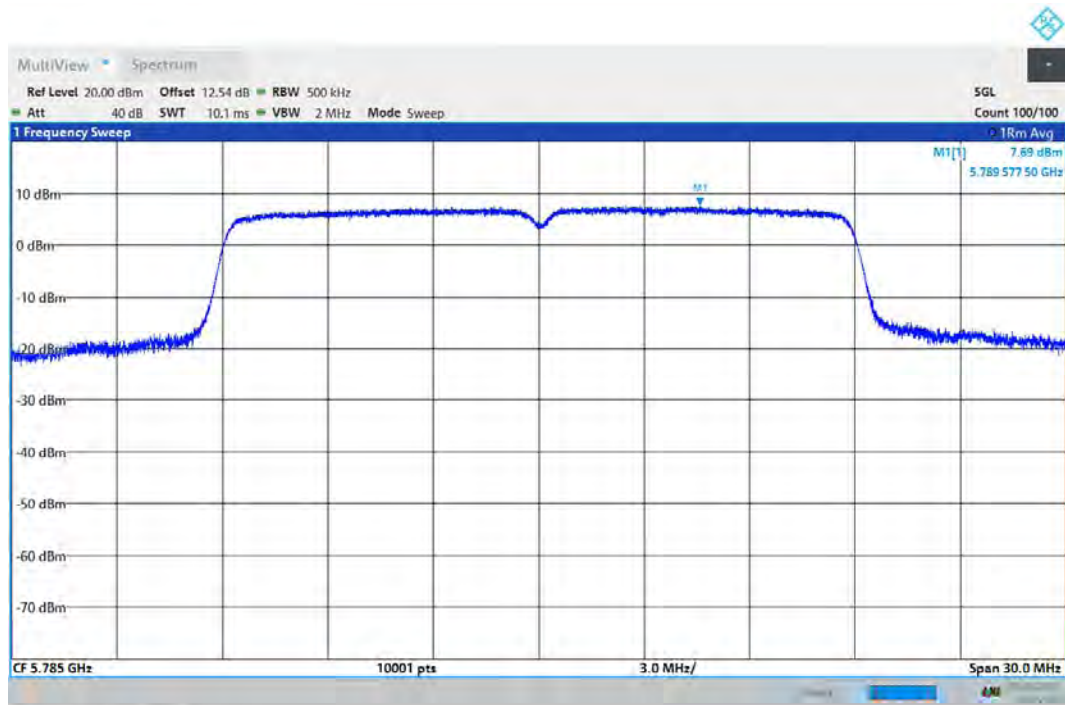

19:32:31 19.08.2023

PSD 802.11n(HT20) 5825MHz Ant1

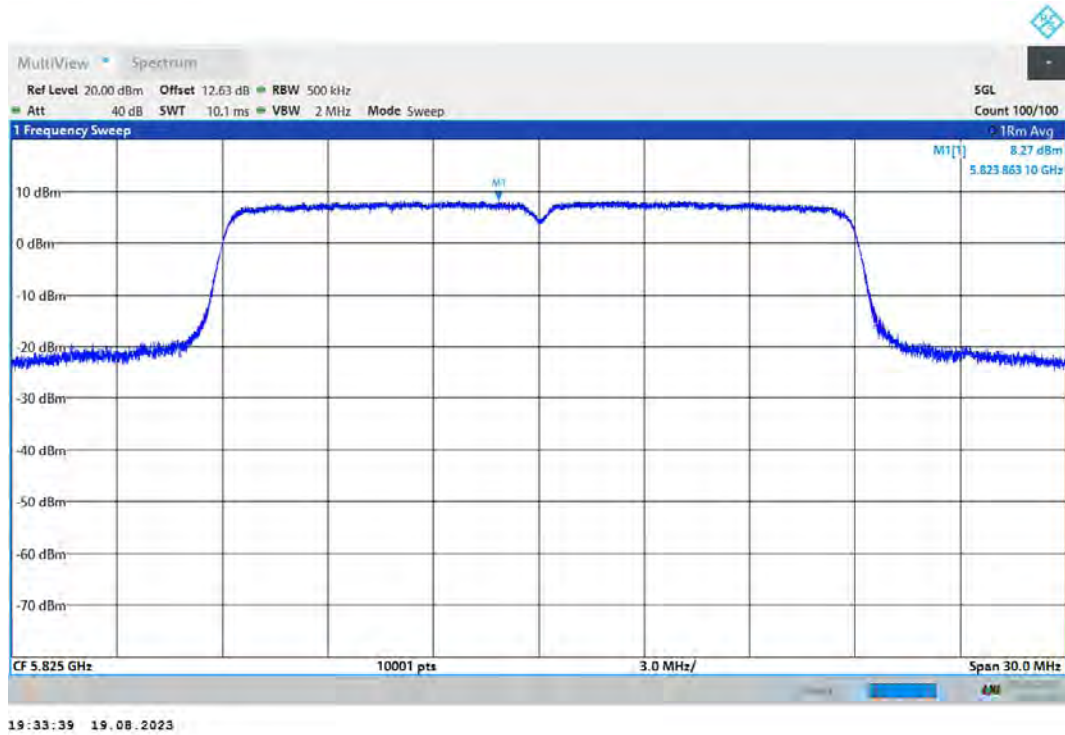

PSD 802.11n(HT20) 5825MHz Ant2

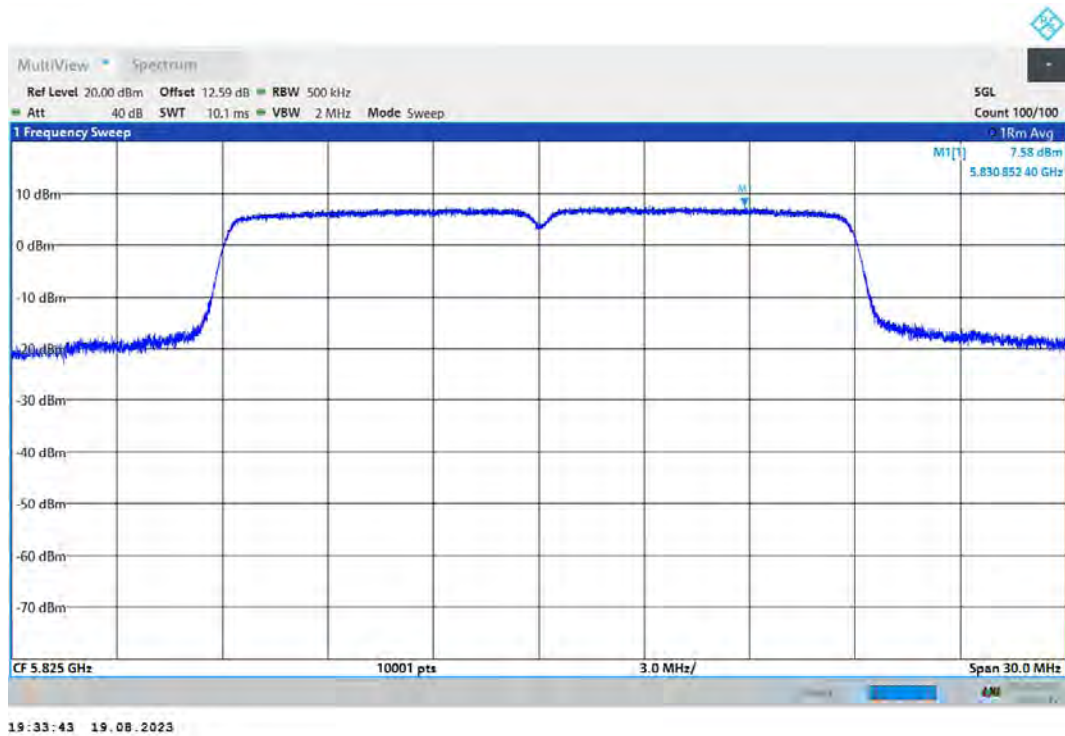

PSD 802.11n(HT40) 5710MHz Ant1

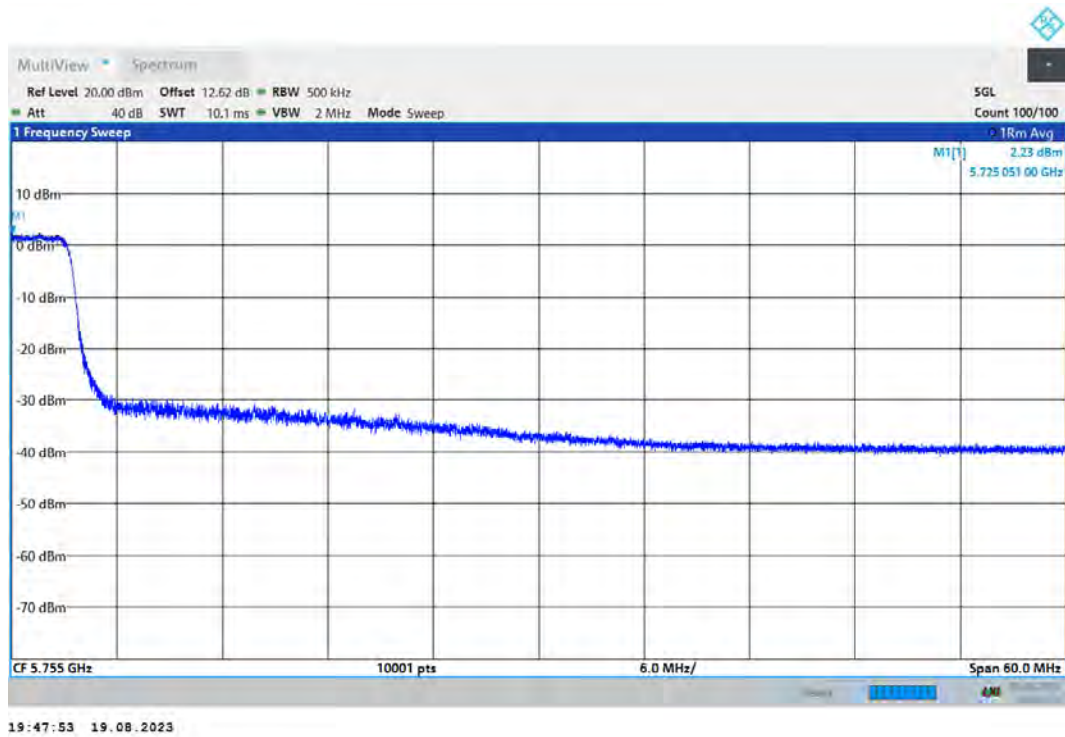

PSD 802.11n(HT40) 5710MHz Ant2

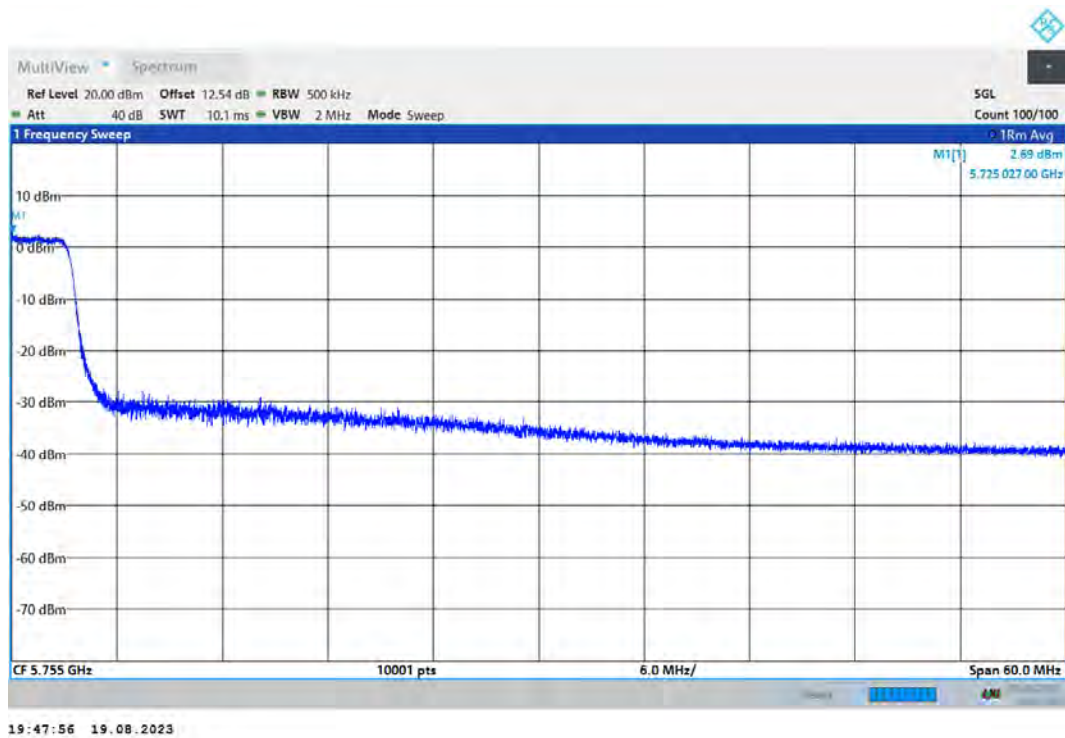

PSD 802.11n(HT40) 5755MHz Ant1

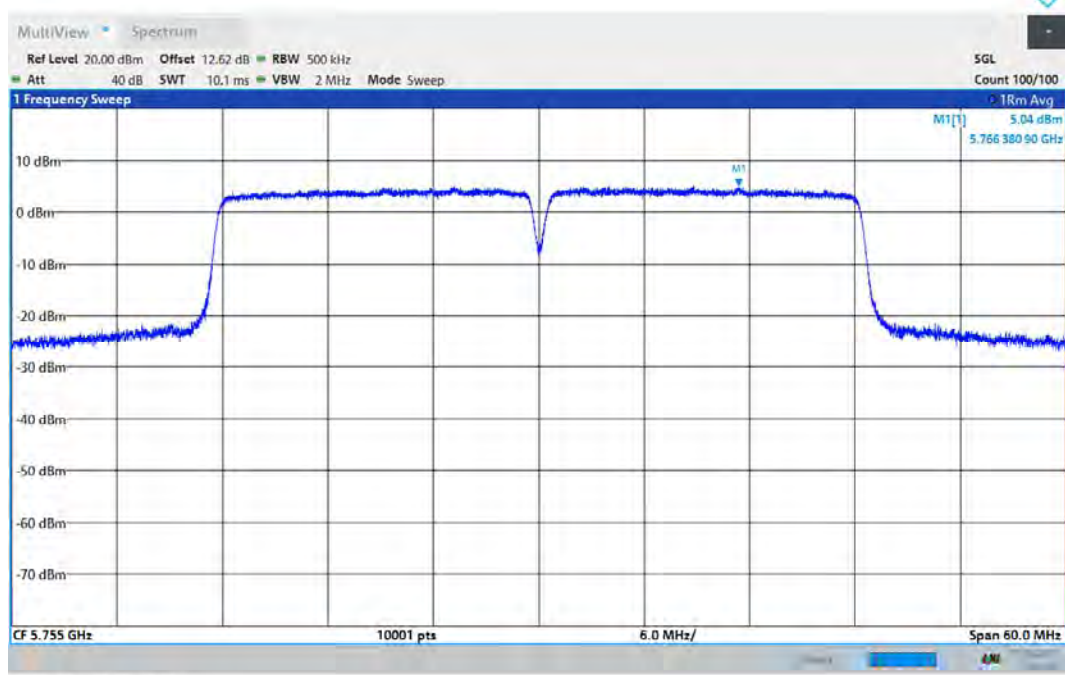

19:46:35 19.08.2023

PSD 802.11n(HT40) 5755MHz Ant2

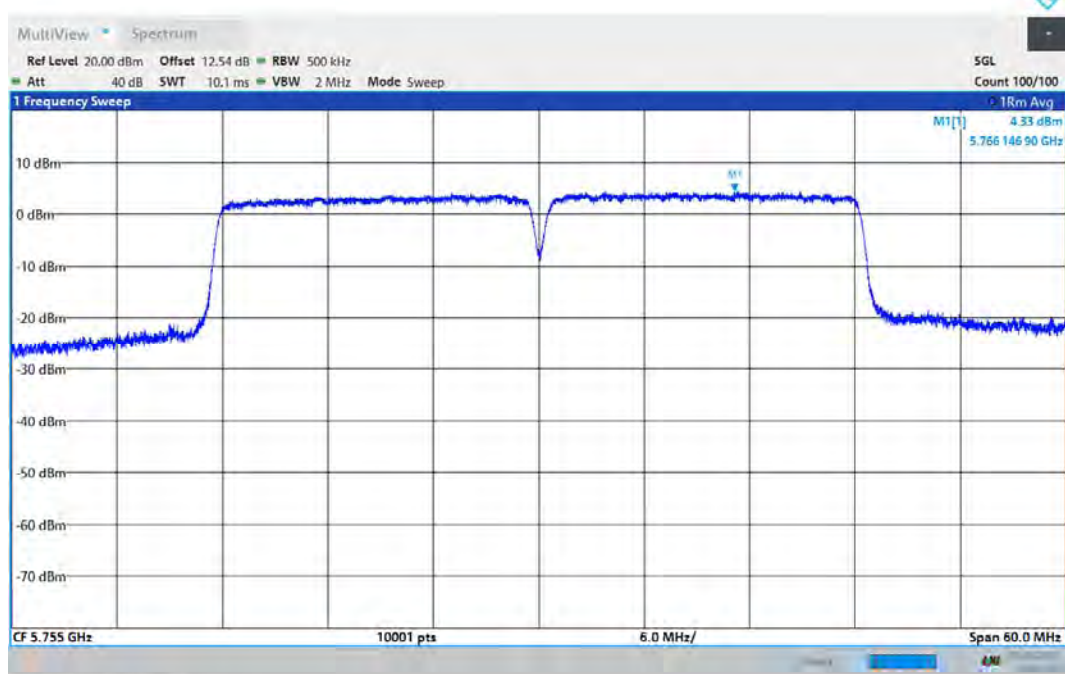

19:46:39 19.08.2023

PSD 802.11n(HT40) 5795MHz Ant1

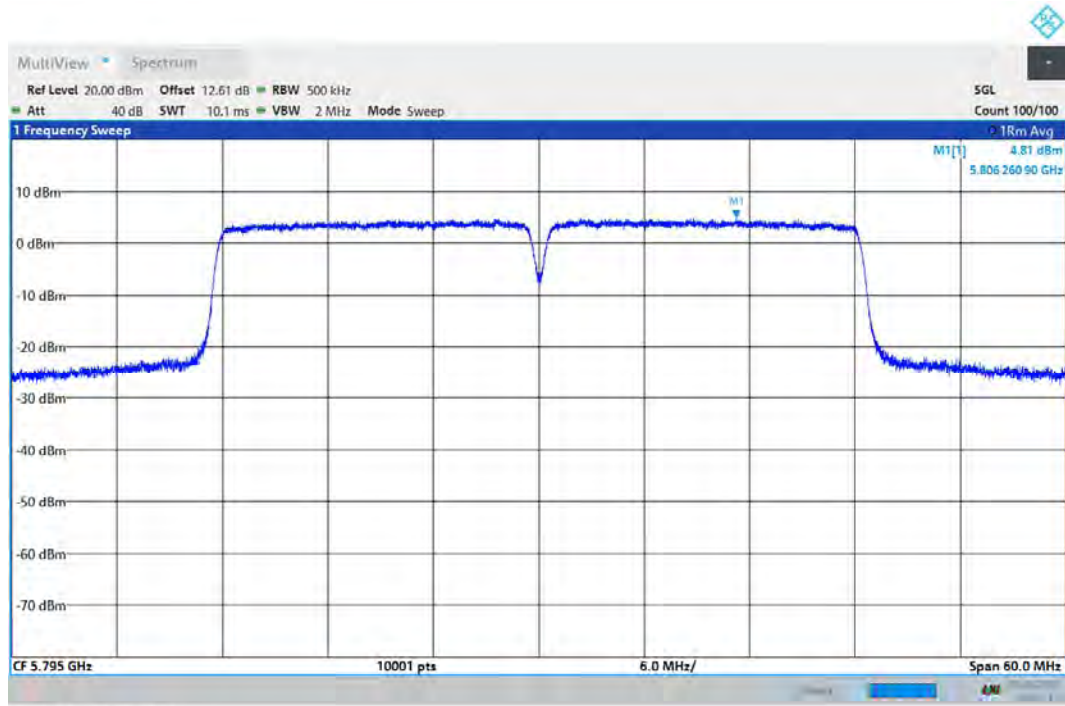

19:47:13 19.08.2023

PSD 802.11n(HT40) 5795MHz Ant2

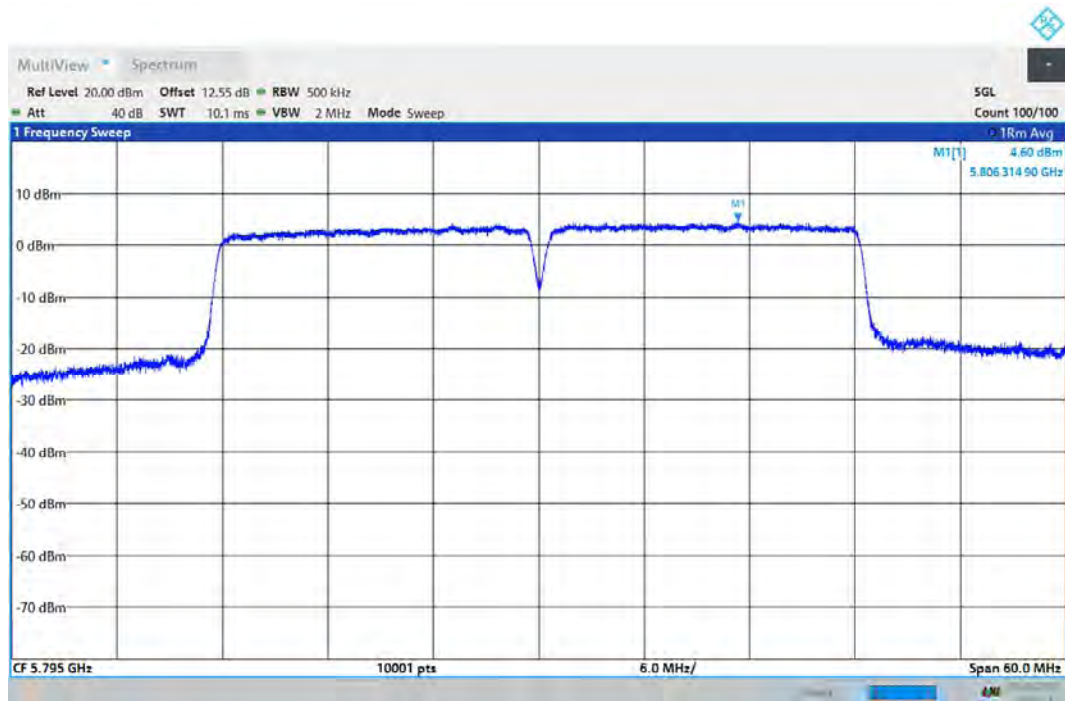

19:47:17 19.08.2023

5.5. Unwanted Emission

Ambient condition

Temperature	Relative humidity	Pressure
23°C ~25°C	45%~50%	101.5kPa

Method of Measurement

The test set-up was made in accordance to the general provisions of ANSI C63.10. The Equipment Under Test (EUT) was set up on a non-conductive table in the semi-anechoic chamber. The test was performed at the distance of 3 m between the EUT and the receiving antenna. The radiated emissions measurements were made in a typical installation configuration.

Sweep the whole frequency band range from 9kHz to the 10th harmonic of the carrier, and the emissions less than 20 dB below the permissible value are reported.

During the test, the height of receive antenna shall be moved from 1 to 4 meters, and the antenna shall be performed under horizontal and vertical polarization. The turntable shall be rotated from 0 to 360 degrees for detecting the maximum of radiated spurious signal level. The measurements shall be repeated with orthogonal polarization of the test antenna. The data of cable loss and antenna factor has been calibrated in full testing frequency range before the testing.

Set the spectrum analyzer in the following:

9kHz~150 kHz

RBW=200Hz, VBW=1kHz/ Sweep=AUTO

150 kHz~30MHz

RBW=9KHz, VBW=30KHz,/ Sweep=AUTO

Below 1GHz

RBW=100kHz / VBW=300kHz / Sweep=AUTO

a) Peak emission levels are measured by setting the instrument as follows:

Above 1GHz

PEAK: RBW=1MHz VBW=3MHz/ Sweep=AUTO

b) Average emission levels are measured by setting the instrument as follows:

Above 1GHz

AVERAGE: RBW=1MHz / VBW=3MHz / Sweep=AUTO

c) Detector: The measurements employing a CISPR quasi-peak detector except for the frequency bands 9-90 kHz, 110-490 kHz and above 1000 MHz. Radiated emission limits in these three bands are based on measurements employing an average detector.

d) Averaging type = power (i.e., rms) (As an alternative, the detector and averaging type may be set for linear voltage averaging. Some instruments require linear display mode to use linear voltage averaging. Log or dB averaging shall not be used.)

e) Sweep time = auto.

f) Perform a trace average of at least 100 traces if the transmission is continuous. If the transmission is not continuous, then the number of traces shall be increased by a factor of 1 / D, where D is the duty cycle. For example, with 50% duty cycle, at least 200 traces shall be averaged. (If a specific emission is demonstrated to be continuous—i.e., 100% duty cycle—then rather than turning ON and

OFF with the transmit cycle, at least 100 traces shall be averaged.)

g) If tests are performed with the EUT transmitting at a duty cycle less than 98%, then a correction factor shall be added to the measurement results prior to comparing with the emission limit, to compute the emission level that would have been measured had the test been performed at 100% duty cycle. The correction factor is computed as follows:

1) If power averaging (rms) mode was used in the preceding step e), then the correction factor is $[10 \log (1 / D)]$, where D is the duty cycle. For example, if the transmit duty cycle was 50%, then 3 dB shall be added to the measured emission levels.

2) If linear voltage averaging mode was used in the preceding step e), then the correction factor is $[20 \log (1 / D)]$, where D is the duty cycle. For example, if the transmit duty cycle was 50%, then 6 dB shall be added to the measured emission levels.

3) If a specific emission is demonstrated to be continuous (100% duty cycle) rather than turning ON and OFF with the transmit cycle, then no duty cycle correction is required for that emission.

Reduce the video bandwidth until no significant variations in the displayed signal are observed in subsequent traces, provided the video bandwidth is no less than 1 Hz. For regulatory requirements that specify averaging only over the transmit duration (e.g., digital transmission system [DTS] and Unlicensed National Information Infrastructure [U-NII]), the video bandwidth shall be greater than $[1 / (\text{minimum transmitter on time})]$ and no less than 1 Hz.

The field strength of spurious emission was measured in the following position: EUT stand-up position (Z axis), lie-down position (X, Y axis). The worst emission was found in stand-up position (Z axis) and the loop antenna is vertical, others antenna are vertical and horizontal.

The test is in transmitting mode.

Test setup

9KHz~ 30MHz

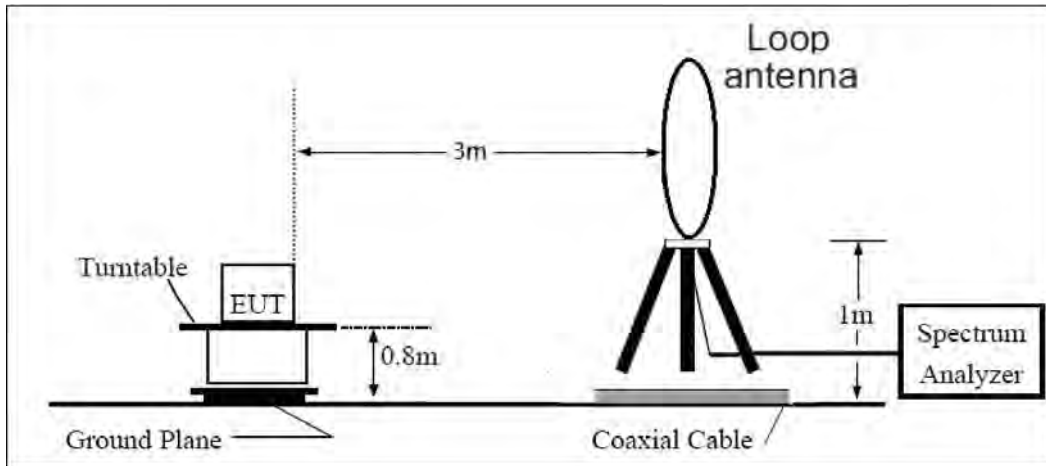

30MHz~ 1GHz

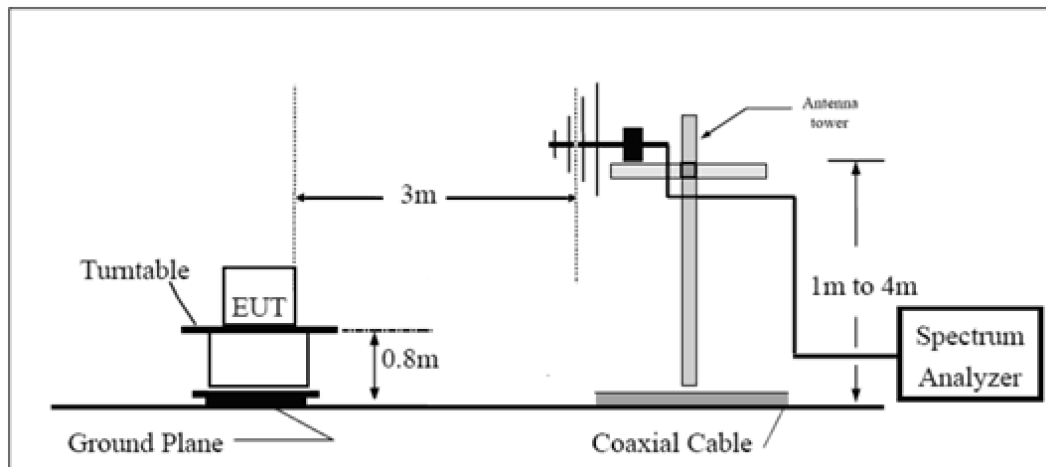

Above 1GHz

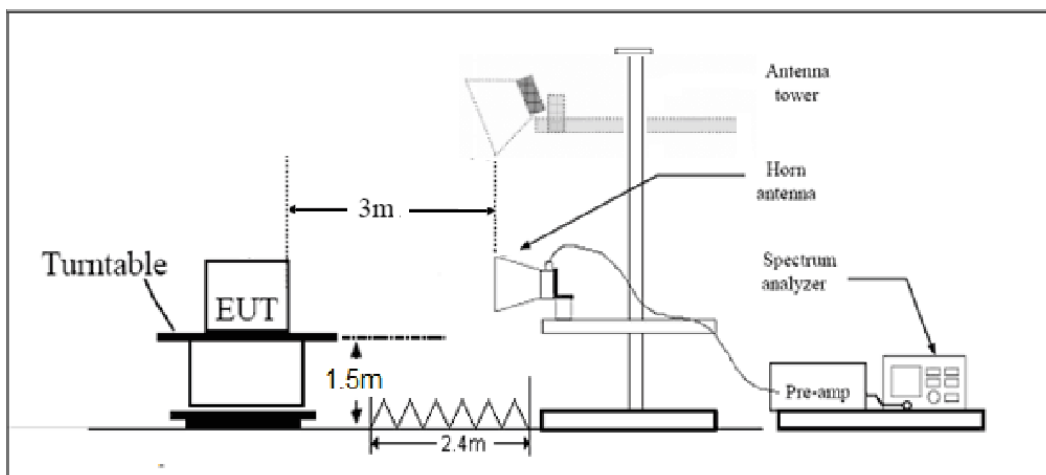

Note: Area side:2.4mX3.6m

Limits

- (1) For transmitters operating in the 5725-5850 MHz band: All emissions shall be limited to a level of -27 dBm/MHz at 75 MHz or more above or below the band edge increasing linearly to 10 dBm/MHz at 25 MHz above or below the band edge, and from 25 MHz above or below the band edge increasing linearly to a level of 15.6 dBm/MHz at 5 MHz above or below the band edge, and from 5 MHz above or below the band edge increasing linearly to a level of 27 dBm/MHz at the band edge.
- (2) For transmitters operating in the 5.15-5.25 GHz band: All emissions outside of the 5.15-5.35 GHz band shall not exceed an e.i.r.p. of -27 dBm/MHz(68.2dBμV/m).
- (3) For transmitters operating in the 5.25-5.35 GHz band: All emissions outside of the 5.15-5.35 GHz band shall not exceed an e.i.r.p. of -27 dBm/MHz(68.2dBμV/m).
- (4) For transmitters operating in the 5.47-5.725 GHz band: All emissions outside of the 5.47-5.725 GHz band shall not exceed an e.i.r.p. of -27 dBm/MHz(68.2dBμV/m).

Note: the following formula is used to convert the EIRP to field strength

§1、 $E[\text{dB}\mu\text{V}/\text{m}] = \text{EIRP}[\text{dBm}] - 20 \log(d[\text{meters}]) + 104.77$, where E = field strength and

d = distance at which field strength limit is specified in the rules;

§2、 $E[\text{dB}\mu\text{V}/\text{m}] = \text{EIRP}[\text{dBm}] + 95.2$, for d = 3 meters

- (5) Unwanted spurious emissions fallen in restricted bands per FCC Part15.205 shall comply with the general field strength limits set forth in § 15.209 as below table.

Frequency of emission (MHz)	Field strength(μV/m)	Field strength(dBμV/m)
0.009–0.490	2400/F(kHz)	/
0.490–1.705	24000/F(kHz)	/
1.705–30.0	30	/
30-88	100	40
88-216	150	43.5
216-960	200	46
Above960	500	54

MHz	MHz	MHz	GHz
0.090 - 0.110	16.42 - 16.423	399.9 - 410	4.5 - 5.15
0.495 - 0.505	16.69475 - 16.69525	608 - 614	5.35 - 5.46
2.1735 - 2.1905	16.80425 - 16.80475	960 - 1240	7.25 - 7.75
4.125 - 4.128	25.5 - 25.67	1300 - 1427	8.025 - 8.5
4.17725 - 4.17775	37.5 - 38.25	1435 - 1626.5	9.0 - 9.2
4.20725 - 4.20775	73 - 74.6	1645.5 - 1646.5	9.3 - 9.5
6.215 - 6.218	74.8 - 75.2	1660 - 1710	10.6 - 12.7
6.26775 - 6.26825	108 - 121.94	1718.8 - 1722.2	13.25 - 13.4
6.31175 - 6.31225	123 - 138	2200 - 2300	14.47 - 14.5
8.291 - 8.294	149.9 - 150.05	2310 - 2390	15.35 - 16.2
8.362 - 8.366	156.52475 - 156.52525	2483.5 - 2500	17.7 - 21.4
8.37625 - 8.38675	156.7 - 156.9	2690 - 2900	22.01 - 23.12
8.41425 - 8.41475	162.0125 - 167.17	3260 - 3267	23.6 - 24.0
12.29 - 12.293	167.72 - 173.2	3332 - 3339	31.2 - 31.8
12.51975 - 12.52025	240 - 285	3345.8 - 3358	36.43 - 36.5
12.57675 - 12.57725	322 - 335.4	3600 - 4400	(²)
13.36 - 13.41			

Measurement Uncertainty

The assessed measurement uncertainty to ensure 95% confidence level for the normal distribution is with the coverage factor $k = 1.96$.

Frequency	Uncertainty
9KHz-30MHz	3.55 dB
30MHz-200MHz	4.17 dB
200MHz-1GHz	4.84 dB
1-18GHz	4.35 dB
18-26.5GHz	5.90 dB
26.5GHz~40GHz	5.92 dB

Test Results:

The modulation and bandwidth are similar for 802.11n mode for 20MHz/40MHz and 802.11ac mode for V20MHz/V40MHz, therefore investigated worst case to representative mode in test report.

A symbol (dB μ V/m) in the test plot below means (dB μ V/m)

The signal beyond the limit is carrier.

U-NII-1

802.11a-Channel 36: Peak + Average

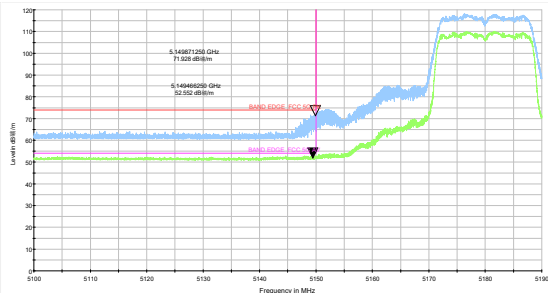

802.11a-Channel 48: Peak + Average

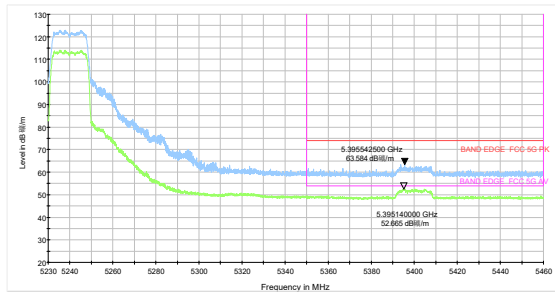

802.11n HT20-Channel 36: Peak + Average

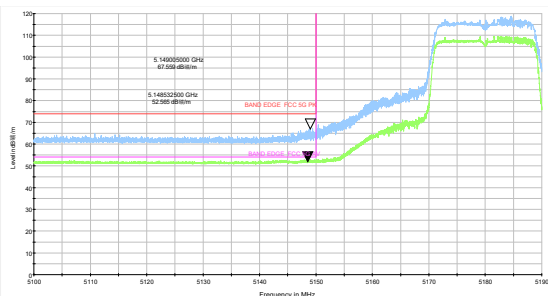

802.11n HT20-Channel 48: Peak + Average

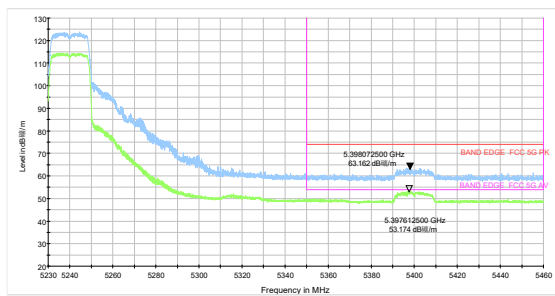

802.11n HT40-Channel 38: Peak + Average

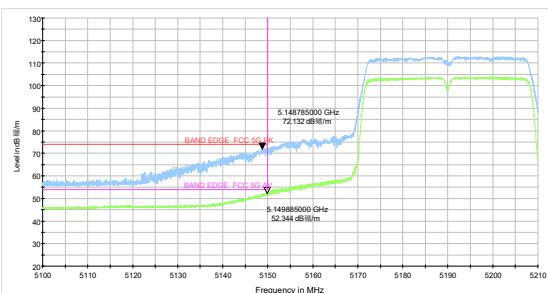

802.11n HT40-Channel 46: Peak + Average

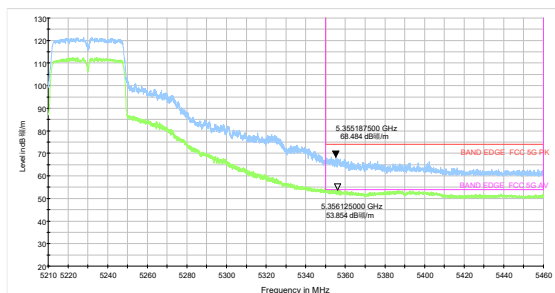

802.11ac VHT80 -Channel 42: Peak + Average

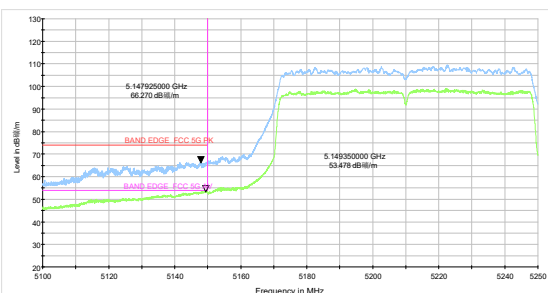

802.11ax HE20-Channel 36: Peak + Average

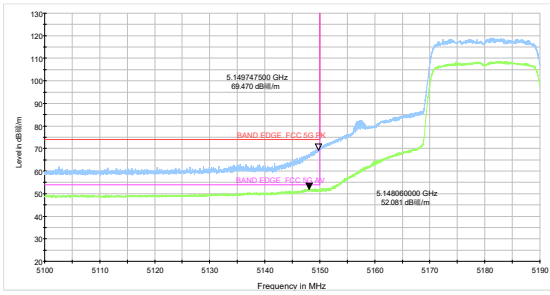

802.11ax HE20-Channel 48: Peak + Average

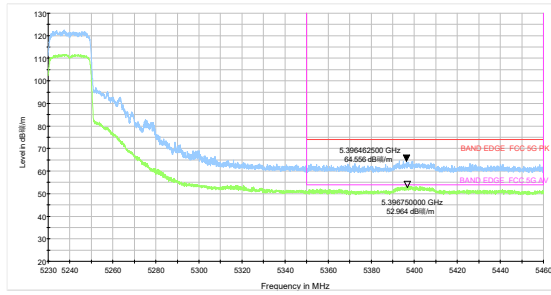

802.11ax HE40-Channel 38: Peak + Average

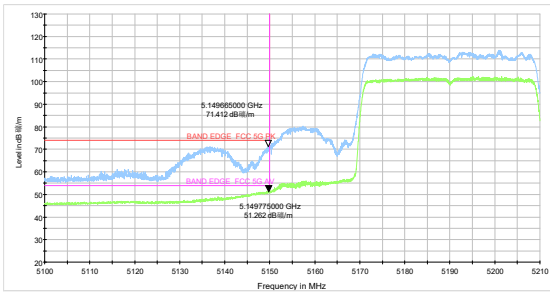

802.11ax HE40-Channel 46: Peak + Average

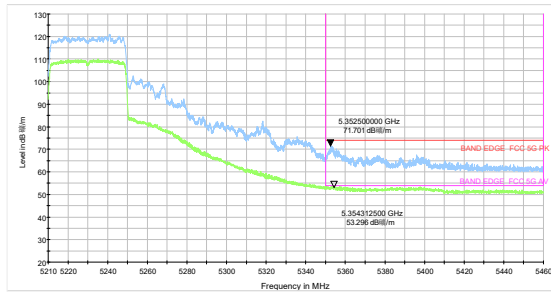

802.11ax HE80 -Channel 42: Peak + Average

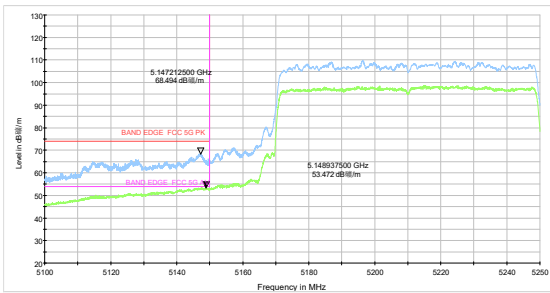

U-NII-2A

802.11a-Channel 52: Peak + Average

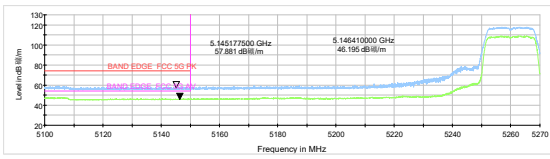

802.11a-Channel 64: Peak + Average

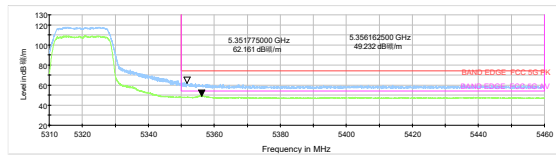

802.11n HT20-Channel 52: Peak + Average

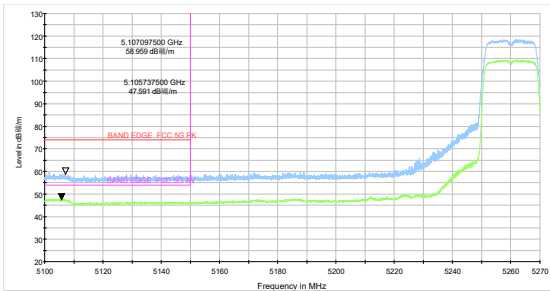

802.11n HT20-Channel 64: Peak + Average

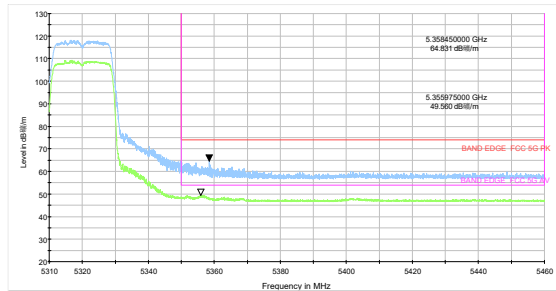

802.11n HT40-Channel 54: Peak + Average

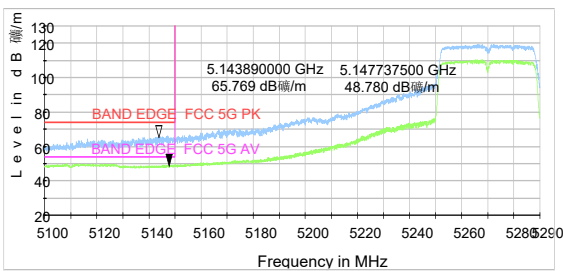

802.11n HT40-Channel 62: Peak + Average

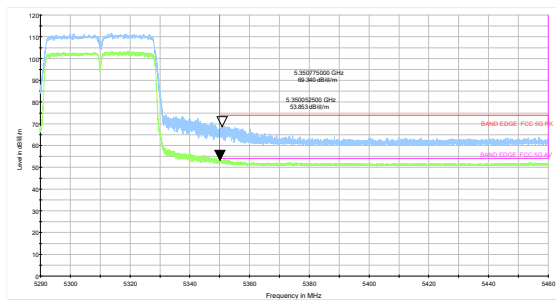

802.11ac VHT80 -Channel 58: Peak + Average

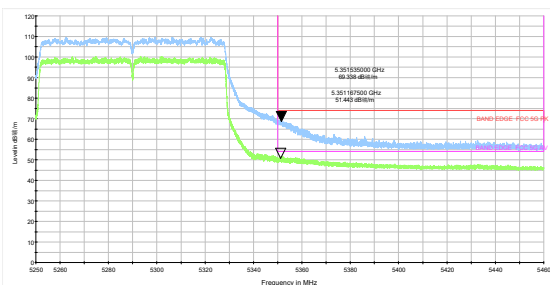

802.11ax HE20 -Channel 52: Peak + Average

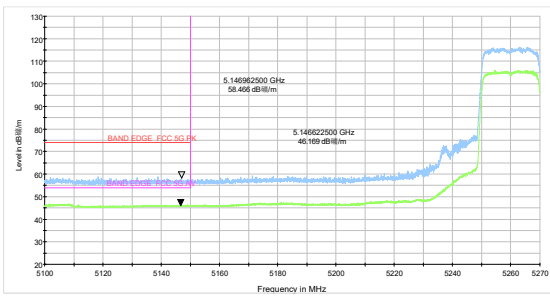

802.11ax HE20 -Channel 64: Peak + Average

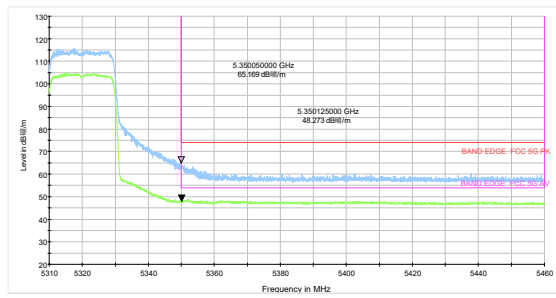

802.11ax HE40-Channel 54: Peak + Average

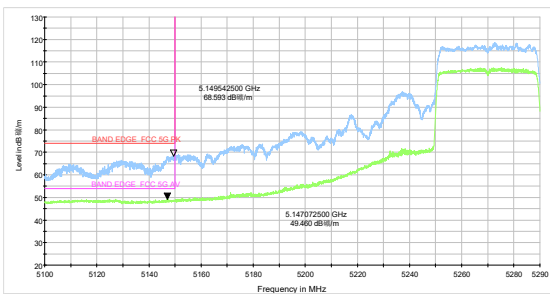

802.11ax HE40-Channel 62: Peak + Average

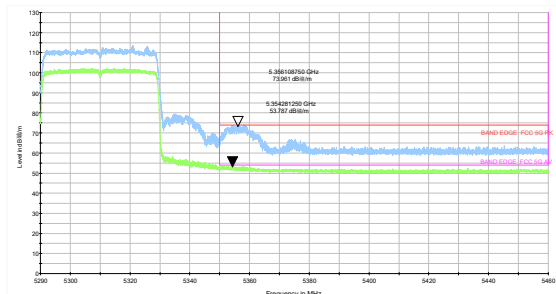

802.11ax HE80 -Channel 58: Peak + Average

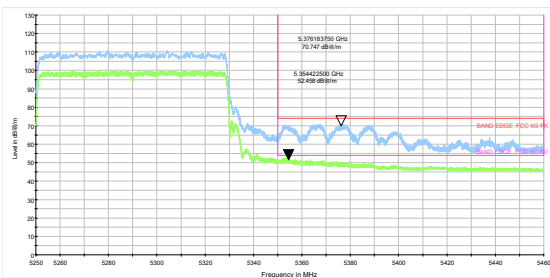

802.11ax HE160-Channel 50: Peak + Average

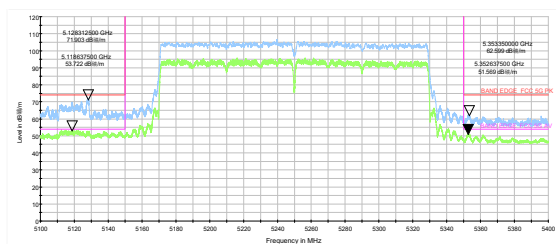

U-NII-2C

802.11a-Channel 100: Peak + Average

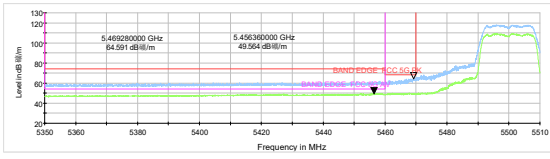

802.11a-Channel 140: Peak

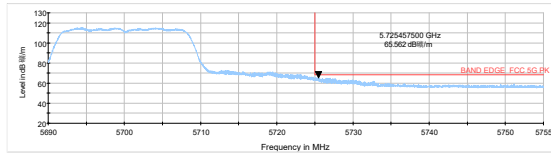

802.11a-Channel 144: Peak

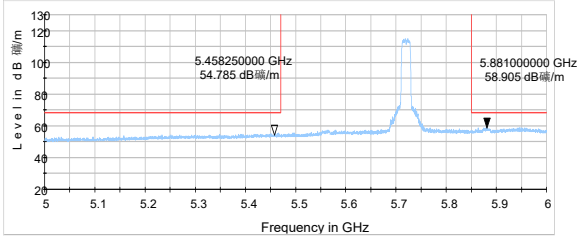

802.11n HT20-Channel 100: Peak + Average

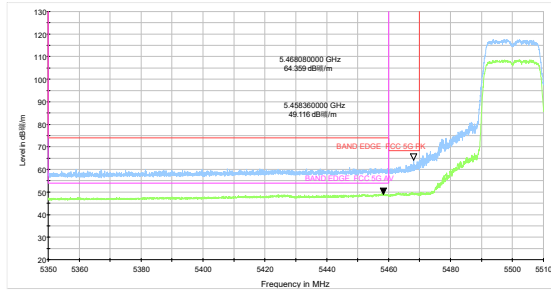

802.11n HT20-Channel 140: Peak

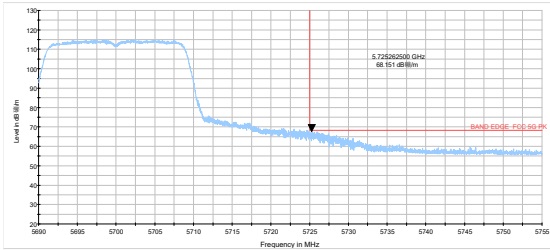

802.11n HT20-Channel 144: Peak

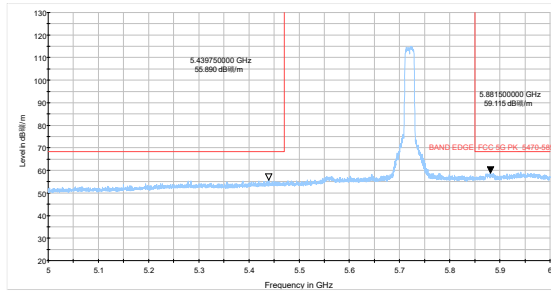

802.11n HT40-Channel 102: Peak + Average

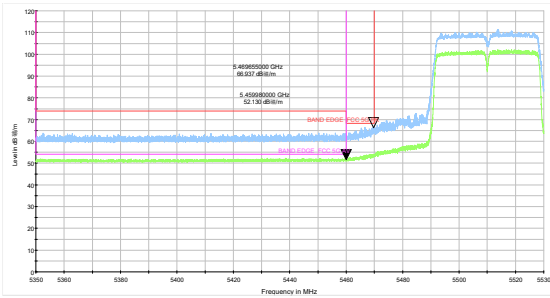

802.11n HT40-Channel 134: Peak

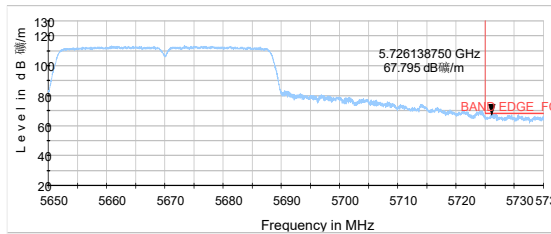

802.11n HT40-Channel 142: Peak

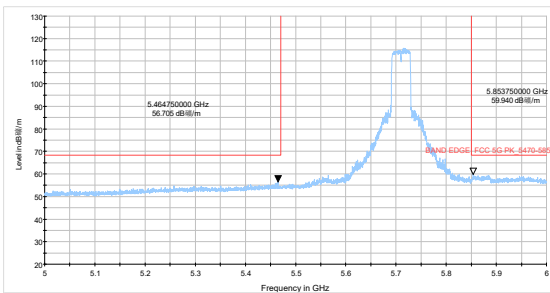

802.11ac VHT80-Channel 106: Peak + Average

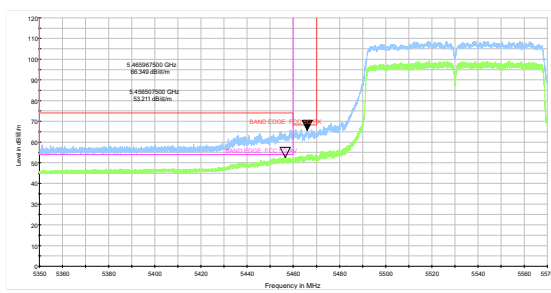

802.11ac VHT80-Channel 122: Peak

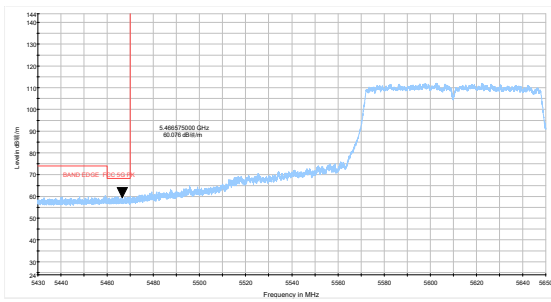

802.11ac VHT80-Channel 138: Peak

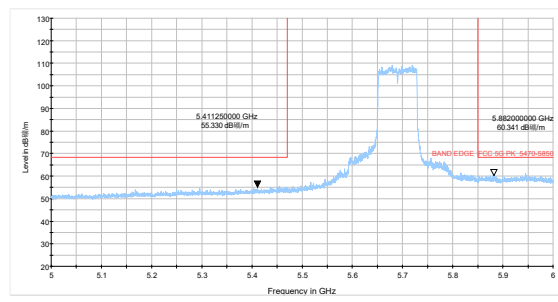

802.11ax HE20 -Channel 100: Peak + Average

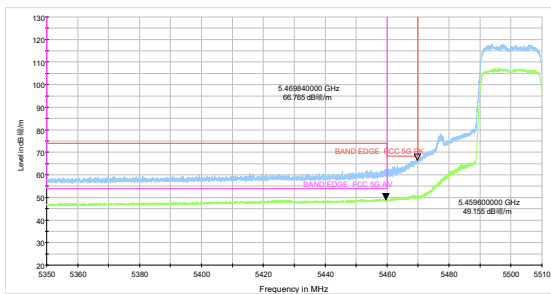

802.11ax HE20-Channel 140: Peak

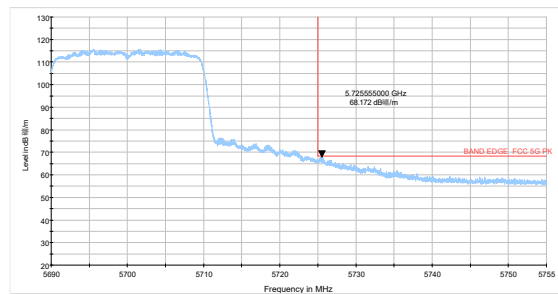

802.11ax HE20-Channel 144: Peak

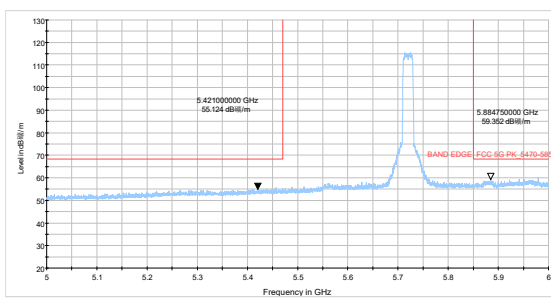

802.11ax HE40-Channel 102: Peak + Average

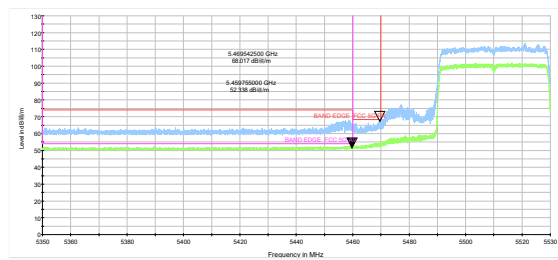

802.11ax HE40-Channel 134: Peak

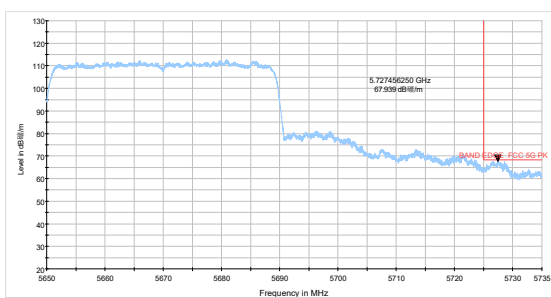

802.11ax HE40-Channel 142: Peak

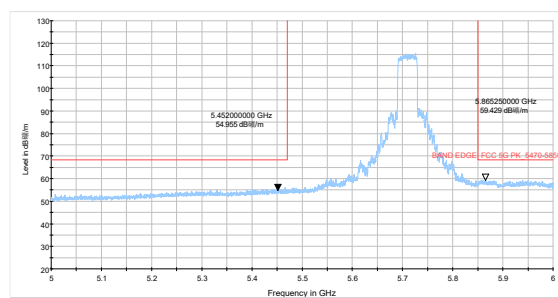

802.11ax HE80-Channel 106: Peak + Average

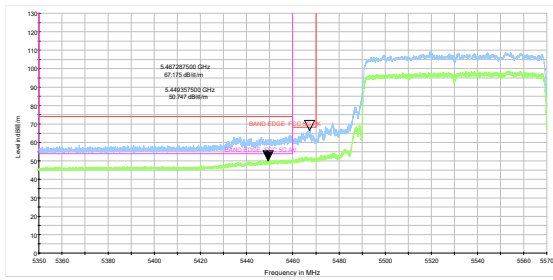

802.11ax HE80-Channel 122: Peak

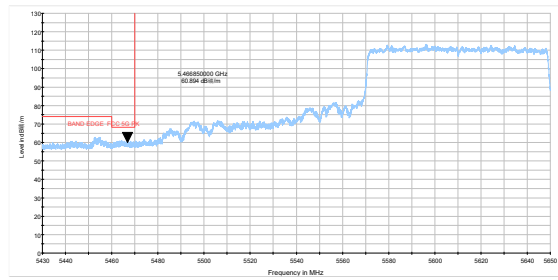

802.11ax HE80-Channel 138: Peak

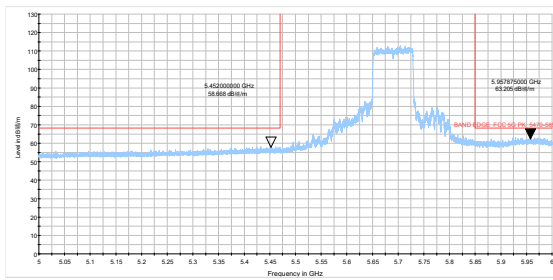

802.11ax HE160-Channel 114: Peak + Average

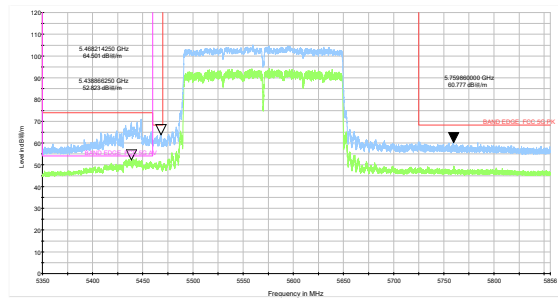

U-NII-3

802.11a-Channel 149: Peak

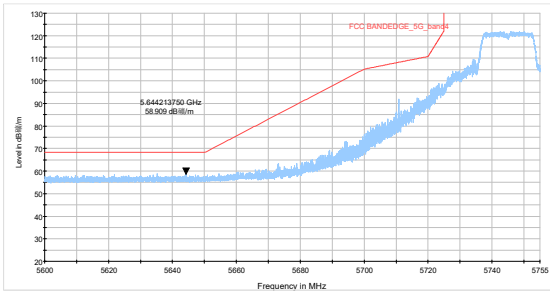

802.11a-Channel 165: Peak

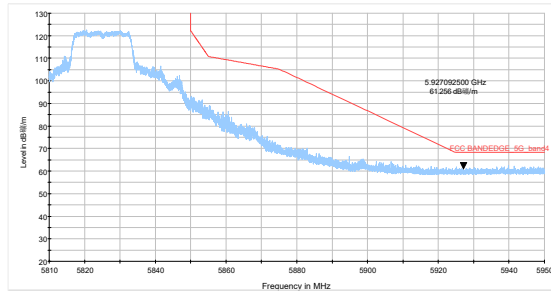

802.11n HT20-Channel 149: Peak

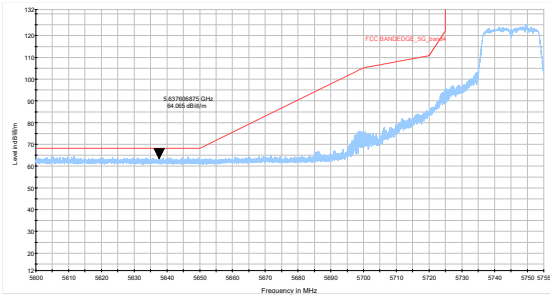

802.11n HT20-Channel 165: Peak

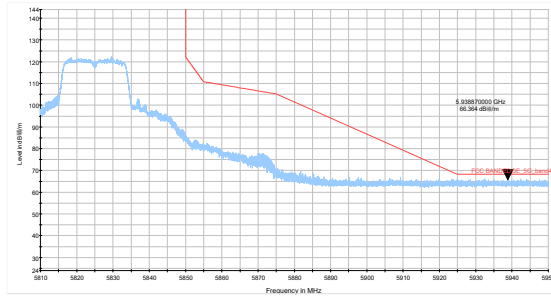

802.11n HT40-Channel 151: Peak

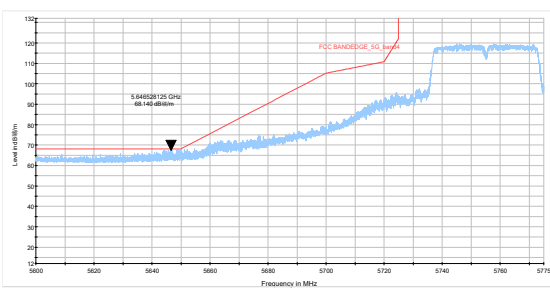

802.11n HT40-Channel 159: Peak

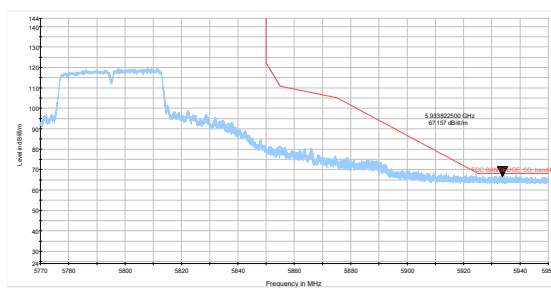

802.11ac VHT80- Channel 155: Peak

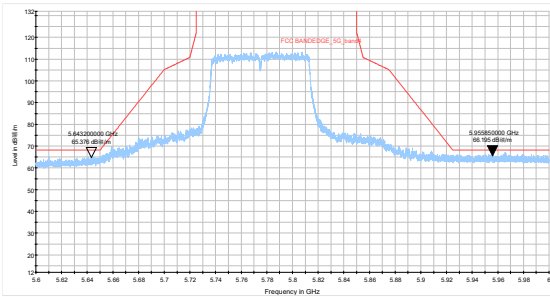

802.11ax HE20-Channel 149: Peak

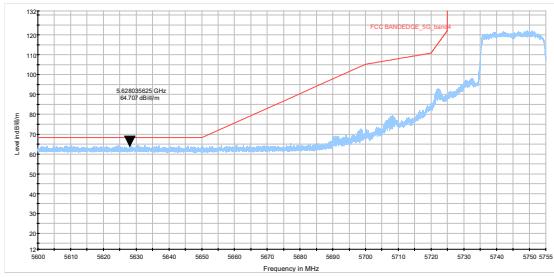

802.11ax HE20-Channel 165: Peak

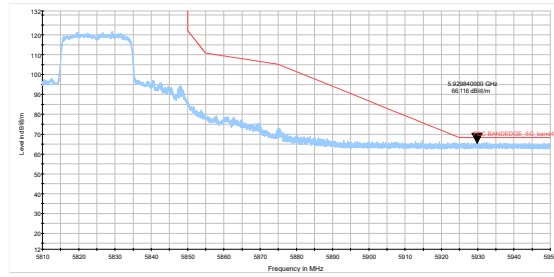

802.11ax HE40-Channel 151: Peak

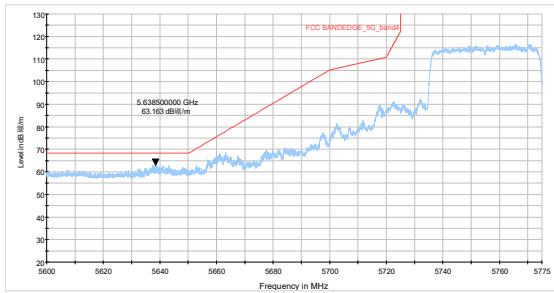

802.11ax HE40-Channel 159: Peak

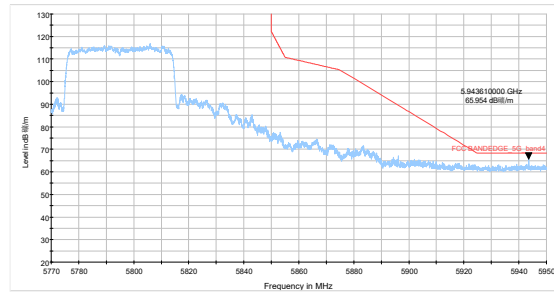

802.11ax HE80- Channel 155: Peak

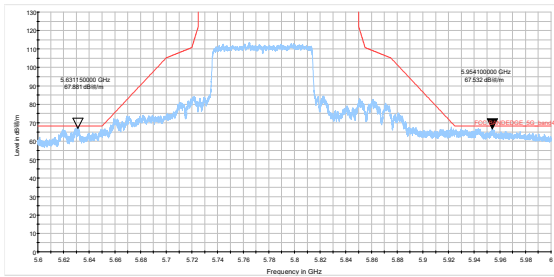

Result of RE

Test result

Sweep the whole frequency band through the range from 9kHz to the 10th harmonic of the carrier, the Emissions in the frequency band 9kHz-30MHz are more than 20dB below the limit are not reported.

A symbol (dB μ V) in the test plot below means (dB μ V/m)

During the test, the Radiates Emission from 30MHz to 1GHz was performed in all modes with all channels, 802.11n (HT40), Channel 46 are selected as the worst condition. The test data of the worst-case condition was recorded in this report.

Continuous TX mode:

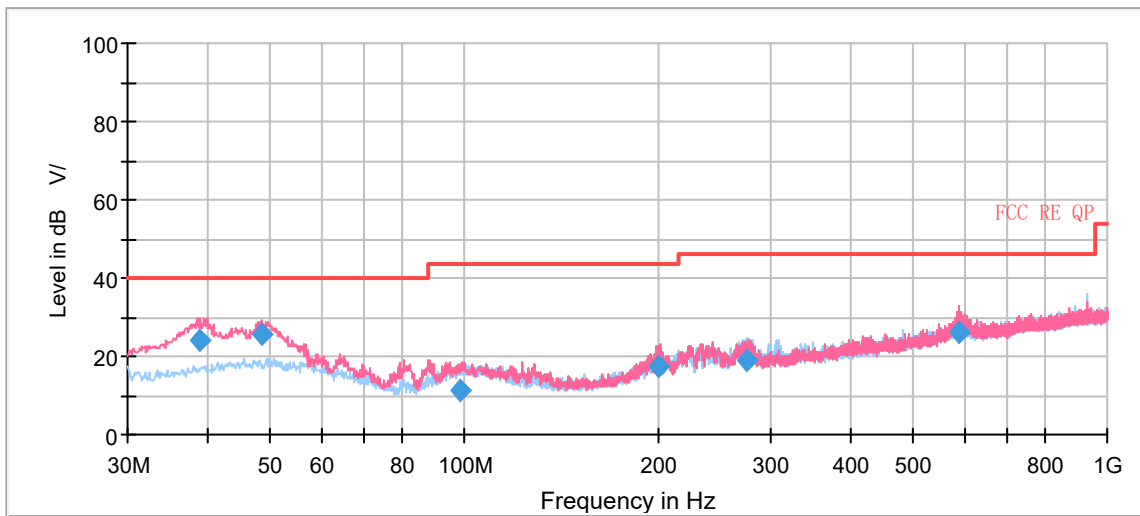

Radiates Emission from 30MHz to 1GHz

Frequency (MHz)	Quasi-Peak (dB μ V/m)	Limit (dB μ V/m)	Margin (dB)	Height (cm)	Polarization	Azimuth (deg)	Correct Factor (dB)
38.727500	24.04	40.00	15.96	100.0	V	202.0	19.1
48.586250	25.89	40.00	14.11	110.0	V	146.0	20.6
98.996250	11.20	43.50	32.30	175.0	V	111.0	18.8
201.291250	17.28	43.50	26.22	100.0	V	176.0	17.9
274.768750	18.87	46.00	27.13	125.0	H	115.0	19.8
588.837500	26.00	46.00	20.00	100.0	V	268.0	26.7

Remark: 1. Correction Factor = Antenna factor + Insertion loss (cable loss + amplifier gain)

2. Margin = Limit – Quasi-Peak

802.11a CH36

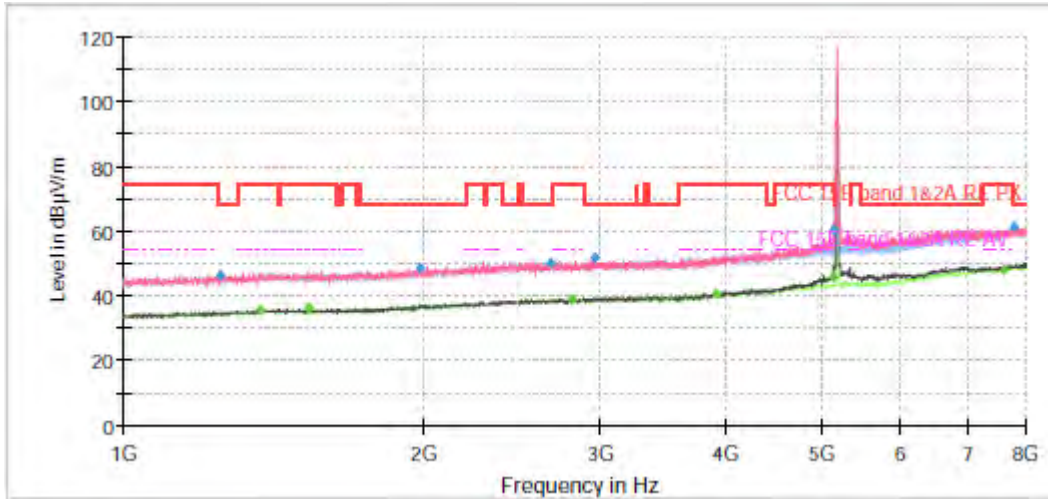

Note: The signal beyond the limit is carrier.
Radiates Emission from 1GHz to 8GHz

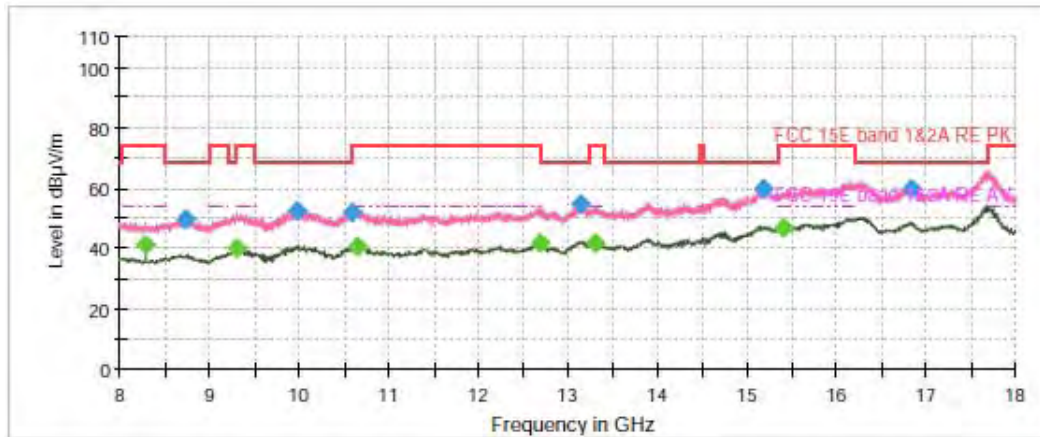

Radiates Emission from 8GHz to 18GHz

Frequency (MHz)	MaxPeak (dB μ V/m)	Average (dB μ V/m)	Limit (dB μ V/m)	Margin (dB)	Meas. Time (ms)	Height (cm)	Pol	Azimuth (deg)	Corr. (dB/m)
1245.88	46.55	---	68.20	21.65	500.00	200.0	V	250.00	-10
1369.25	---	35.65	54.00	18.35	500.00	200.0	V	87.00	-9
1531.13	---	36.01	54.00	17.99	500.00	300.0	V	321.00	-9
1981.75	48.63	---	68.20	19.57	500.00	300.0	V	184.00	-8
2678.25	50.42	---	68.20	17.78	500.00	200.0	H	291.00	-6
2806.88	---	39.25	54.00	14.75	500.00	100.0	H	91.00	-5
2958.25	51.77	---	68.20	16.43	500.00	200.0	V	21.00	-5
3911.13	---	40.91	54.00	13.09	500.00	200.0	V	73.00	-2
5129.13	---	45.86	54.00	8.14	500.00	100.0	V	173.00	2
5142.25	60.23	---	74.00	13.77	500.00	200.0	V	12.00	2
7611.50	---	47.80	54.00	6.20	500.00	300.0	V	157.00	8
7805.75	61.54	---	68.20	6.66	500.00	300.0	H	211.00	9

Remark: 1. Correction Factor = Antenna factor + Insertion loss (cable loss + amplifier gain)

2. Margin = Limit –MAX Peak/ Average

802.11a CH40

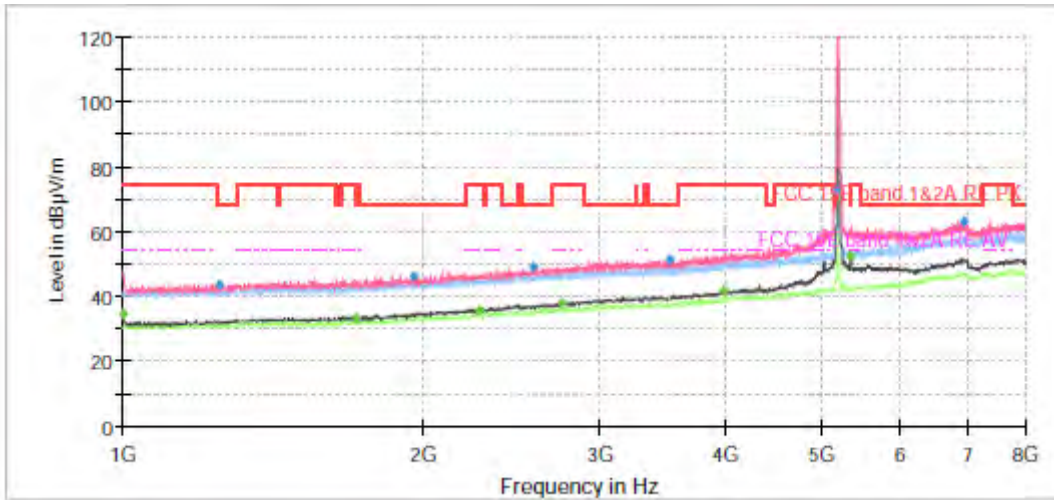

Note: The signal beyond the limit is carrier.
Radiates Emission from 1GHz to 8GHz

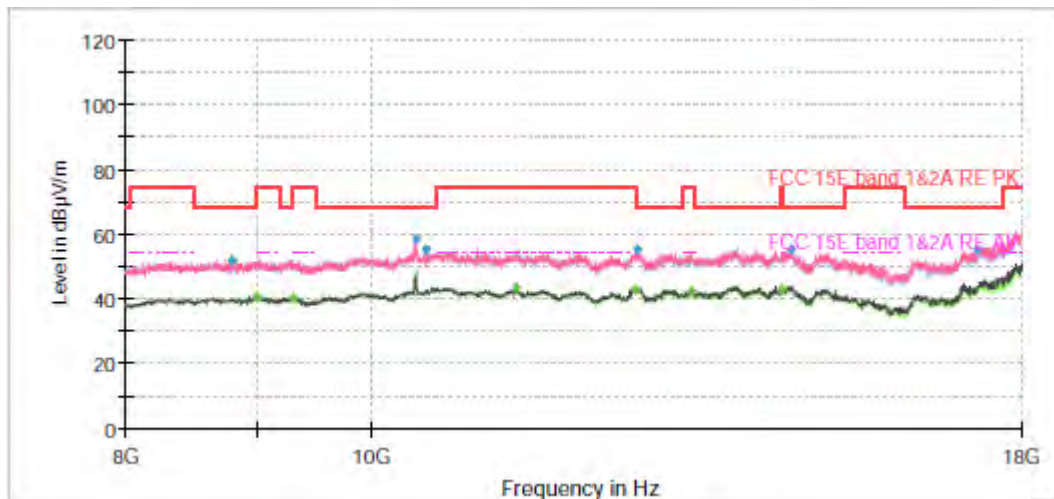

Radiates Emission from 8GHz to 18GHz

Frequency (MHz)	MaxPeak (dB μ V/m)	Average (dB μ V/m)	Limit (dB μ V/m)	Margin (dB)	Meas. Time (ms)	Height (cm)	Pol	Azimuth (deg)	Corr. (dB/m)
1000.00	---	34.67	54.00	19.33	500.00	200.0	V	189.00	-3
1245.88	43.70	---	68.20	24.50	500.00	100.0	V	271.00	-2
1708.75	---	33.75	54.00	20.25	500.00	100.0	V	36.00	0
1955.50	46.24	---	68.20	21.96	500.00	200.0	V	0.00	1
2274.88	---	35.71	54.00	18.30	500.00	100.0	V	182.00	2
2568.88	48.87	---	68.20	19.33	500.00	100.0	V	237.00	3
2752.63	---	38.23	54.00	15.77	500.00	200.0	V	114.00	4
3526.13	51.56	---	68.20	16.64	500.00	100.0	V	210.00	5
3988.13	---	41.60	54.00	12.40	500.00	200.0	V	15.00	6
5146.63	72.55	---	74.00	1.45	500.00	100.0	V	2.00	10
5355.75	---	52.45	54.00	1.55	500.00	200.0	V	153.00	11
6941.25	62.87	---	68.20	5.33	500.00	200.0	V	54.00	14

Remark: 1. Correction Factor = Antenna factor + Insertion loss (cable loss + amplifier gain)

2. Margin = Limit –MAX Peak/ Average

802.11a CH48

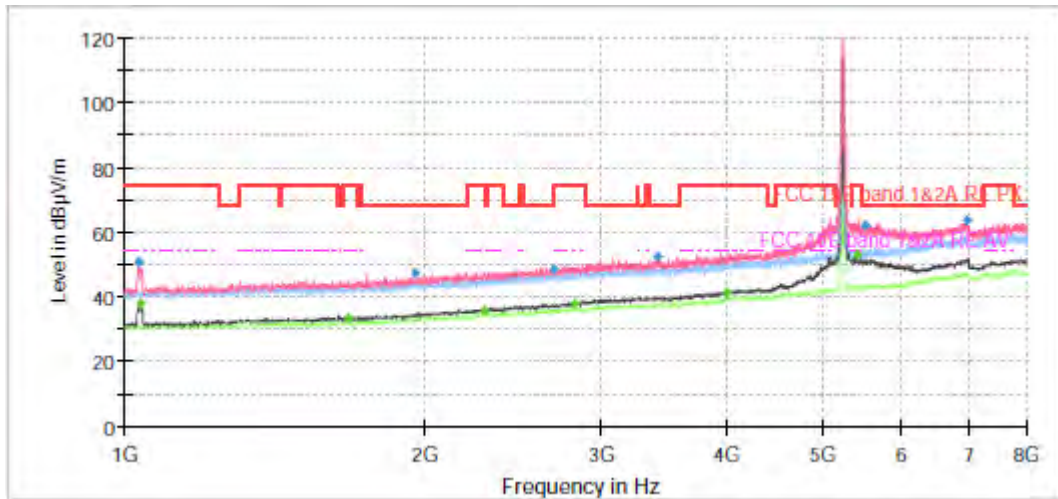

Note: The signal beyond the limit is carrier.
Radiates Emission from 1GHz to 8GHz

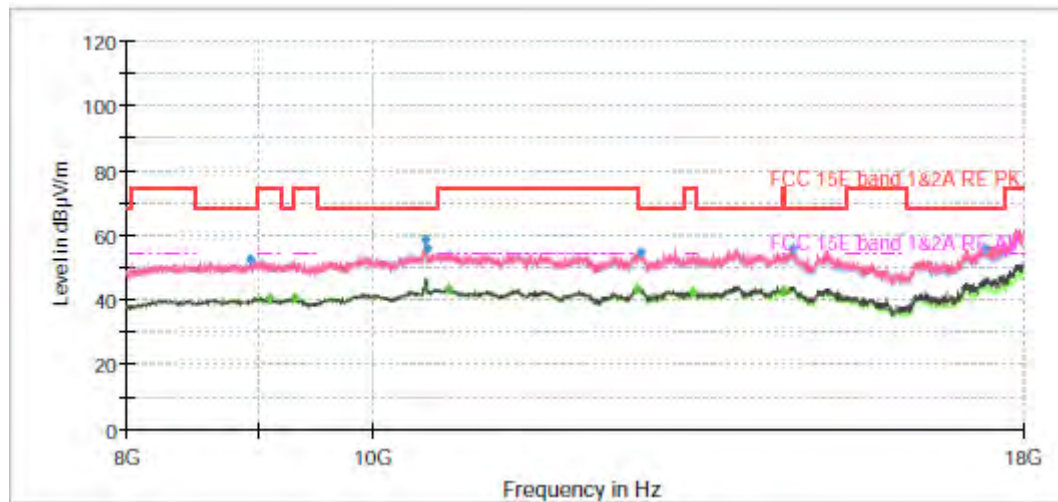

Radiates Emission from 8GHz to 18GHz

Frequency (MHz)	MaxPeak (dB μ V/m)	Average (dB μ V/m)	Limit (dB μ V/m)	Margin (dB)	Meas. Time (ms)	Height (cm)	Pol	Azimuth (deg)	Corr. (dB/m)
1031.50	50.61	---	74.00	23.39	500.00	200.0	V	170.00	-3
1035.00	---	38.03	54.00	15.97	500.00	200.0	V	170.00	-3
1675.50	---	33.75	54.00	20.25	500.00	100.0	V	350.00	-1
1950.25	47.18	---	68.20	21.02	500.00	200.0	V	3.00	1
2295.88	---	36.00	54.00	18.00	500.00	100.0	V	215.00	2
2683.50	48.53	---	68.20	19.67	500.00	200.0	V	0.00	4
2824.38	---	38.15	54.00	15.85	500.00	200.0	V	7.00	4
3418.50	52.19	---	68.20	16.01	500.00	200.0	V	0.00	5
3997.75	---	41.47	54.00	12.53	500.00	200.0	V	224.00	6
5403.88	---	52.80	54.00	1.20	500.00	200.0	V	158.00	11
5502.75	62.22	---	68.20	5.98	500.00	200.0	V	197.00	11
6972.75	63.55	---	68.20	4.65	500.00	200.0	V	285.00	14

Remark: 1. Correction Factor = Antenna factor + Insertion loss (cable loss + amplifier gain)

2. Margin = Limit –MAX Peak/ Average

802.11a CH52

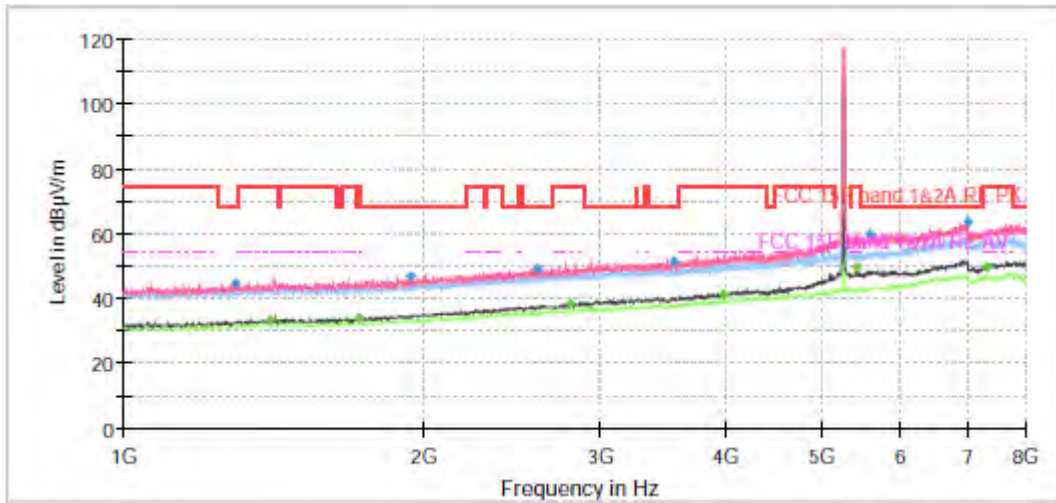

Note: The signal beyond the limit is carrier.
Radiates Emission from 1GHz to 8GHz

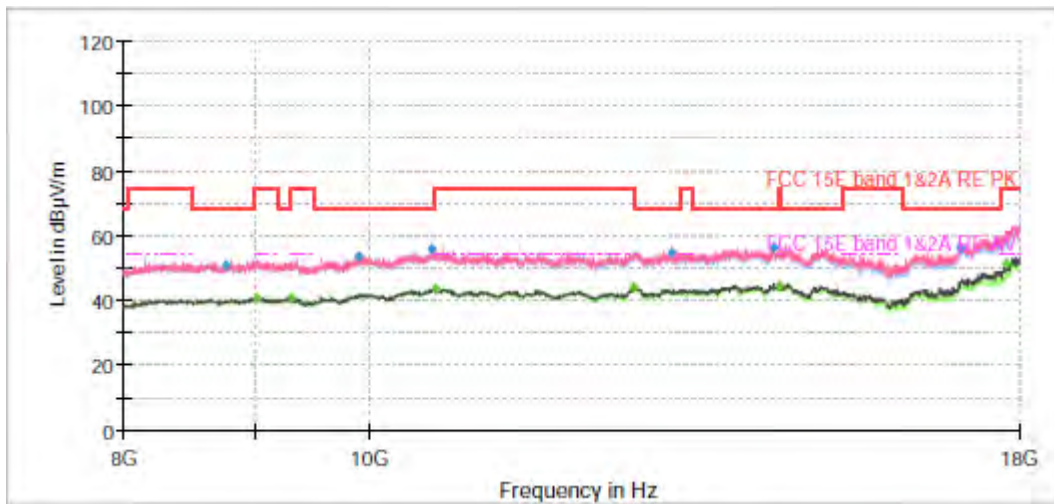

Radiates Emission from 8GHz to 18GHz

Frequency (MHz)	MaxPeak (dB μ V/m)	Average (dB μ V/m)	Limit (dB μ V/m)	Margin (dB)	Meas. Time (ms)	Height (cm)	Pol	Azimuth (deg)	Corr. (dB/m)
1294.88	44.49	---	68.20	23.71	500.00	200.0	V	12.00	-1
1403.38	---	33.47	54.00	20.53	500.00	100.0	V	234.00	-1
1720.13	---	34.23	54.00	19.77	500.00	100.0	V	0.00	0
1933.63	46.64	---	68.20	21.56	500.00	200.0	V	12.00	1
2595.13	49.29	---	68.20	18.91	500.00	200.0	V	82.00	3
2792.88	---	38.37	54.00	15.63	500.00	100.0	V	0.00	4
3546.25	51.48	---	68.20	16.73	500.00	200.0	V	89.00	5
3987.25	---	41.50	54.00	12.50	500.00	200.0	V	109.00	6
5424.00	---	49.77	54.00	4.23	500.00	200.0	V	162.00	11
5586.75	59.88	---	68.20	8.32	500.00	200.0	V	116.00	12
6994.63	63.53	---	68.20	4.67	500.00	200.0	V	12.00	14
7323.63	---	49.87	54.00	4.13	500.00	200.0	V	42.00	15
17777.50	---	51.44	54.00	2.56	500.00	100.0	V	69.00	11

Remark: 1. Correction Factor = Antenna factor + Insertion loss (cable loss + amplifier gain)

2. Margin = Limit - MAX Peak/ Average

802.11a CH60

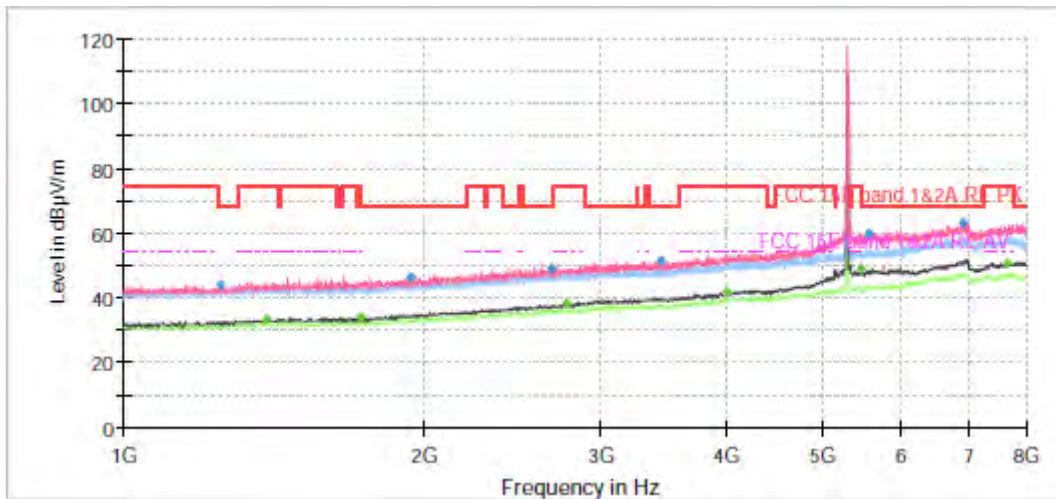

Note: The signal beyond the limit is carrier.
Radiates Emission from 1GHz to 8GHz

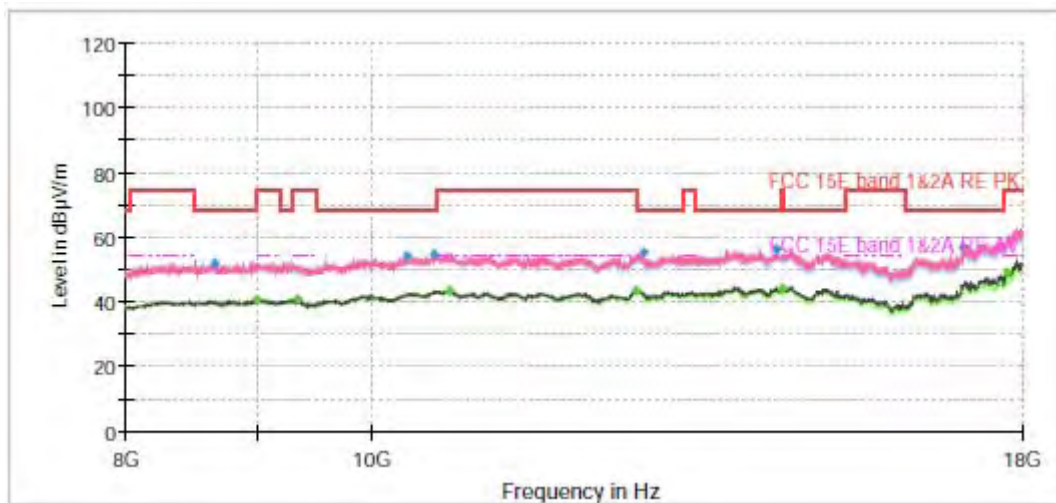

Radiates Emission from 8GHz to 18GHz

Frequency (MHz)	MaxPeak (dB μ V/m)	Average (dB μ V/m)	Limit (dB μ V/m)	Margin (dB)	Meas. Time (ms)	Height (cm)	Pol	Azimuth (deg)	Corr. (dB/m)
1249.38	43.88	---	68.20	24.32	500.00	200.0	V	323.00	-2
1388.50	---	33.23	54.00	20.77	500.00	200.0	V	237.00	-1
1721.88	---	33.87	54.00	20.13	500.00	100.0	V	27.00	0
1938.88	46.37	---	68.20	21.83	500.00	100.0	V	300.00	1
2675.63	49.20	---	68.20	19.00	500.00	100.0	V	147.00	4
2770.13	---	38.42	54.00	15.58	500.00	100.0	V	140.00	4
3439.50	51.51	---	68.20	16.69	500.00	100.0	V	16.00	5
3998.63	---	41.96	54.00	12.04	500.00	100.0	V	34.00	6
5458.13	---	49.19	54.00	4.81	500.00	100.0	V	2.00	11
5562.25	59.85	---	68.20	8.35	500.00	100.0	V	21.00	12
6896.63	62.81	---	68.20	5.39	500.00	200.0	V	156.00	13
7643.00	---	50.99	54.00	3.01	500.00	200.0	V	0.00	17
17756.25	---	49.30	54.00	4.70	500.00	100.0	V	150.00	11

Remark: 1. Correction Factor = Antenna factor + Insertion loss (cable loss + amplifier gain)

2. Margin = Limit - MAX Peak/ Average

802.11a CH64

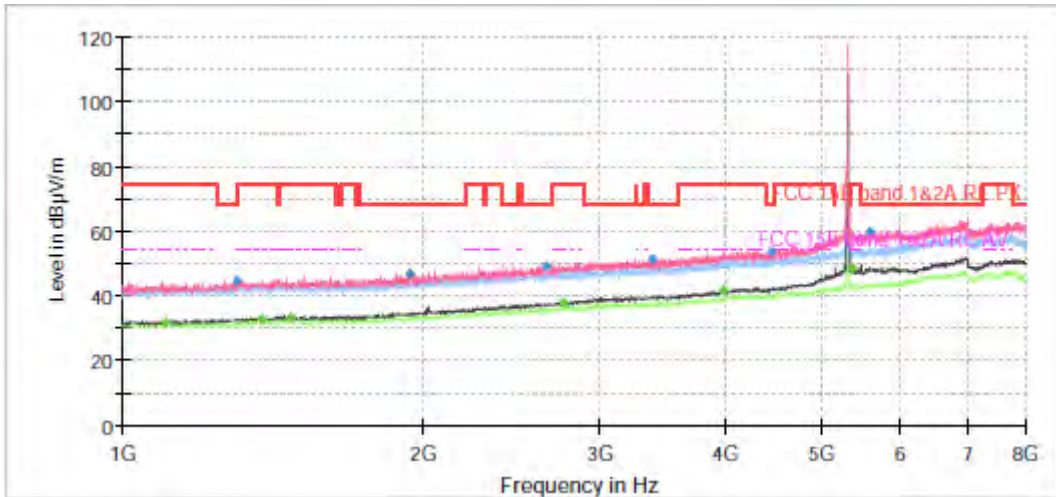

Note: The signal beyond the limit is carrier.
Radiates Emission from 1GHz to 8GHz

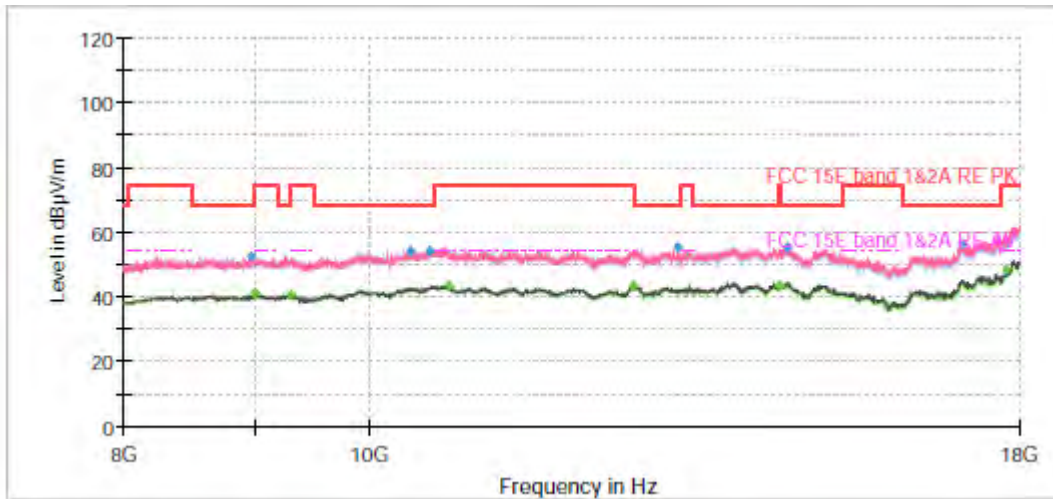

Radiates Emission from 8GHz to 18GHz

Frequency (MHz)	MaxPeak (dB μ V/m)	Average (dB μ V/m)	Limit (dB μ V/m)	Margin (dB)	Meas. Time (ms)	Height (cm)	Pol	Azimuth (deg)	Corr. (dB/m)
1101.50	---	32.05	54.00	21.95	500.00	100.0	V	196.00	-2
1298.38	44.59	---	68.20	23.61	500.00	200.0	V	204.00	-1
1376.25	---	33.19	54.00	20.81	500.00	200.0	V	143.00	-1
1472.50	---	33.69	54.00	20.31	500.00	200.0	V	356.00	-1
1937.13	46.68	---	68.20	21.52	500.00	200.0	V	0.00	1
2649.38	49.33	---	68.20	18.87	500.00	100.0	V	20.00	4
2763.13	---	38.10	54.00	15.90	500.00	100.0	V	2.00	4
3383.50	51.51	---	68.20	16.69	500.00	200.0	V	359.00	5
3984.63	---	41.70	54.00	12.30	500.00	200.0	V	150.00	6
4448.38	53.50	---	68.20	14.70	500.00	200.0	V	284.00	7
5356.63	---	48.82	54.00	5.18	500.00	200.0	V	332.00	11
5588.50	59.66	---	68.20	8.54	500.00	100.0	V	0.00	12
17771.25	---	48.53	54.00	5.47	500.00	100.0	V	0.00	11

Remark: 1. Correction Factor = Antenna factor + Insertion loss (cable loss + amplifier gain)

2. Margin = Limit - MAX Peak/ Average

802.11a CH100

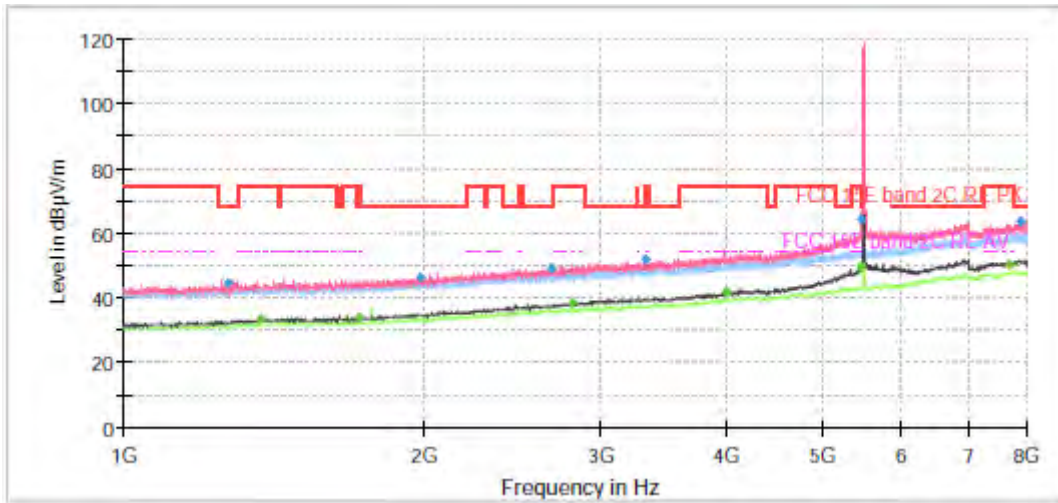

Note: The signal beyond the limit is carrier.
Radiates Emission from 1GHz to 8GHz

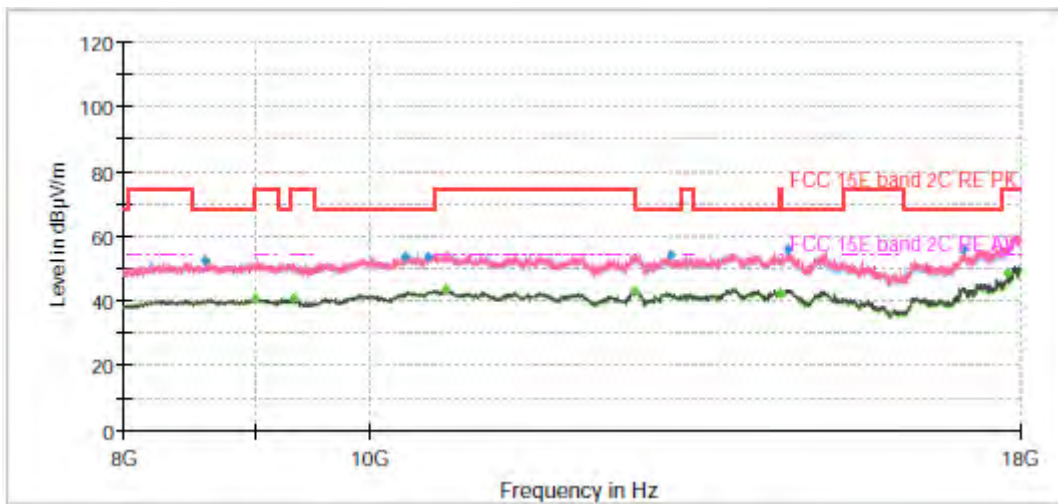

Radiates Emission from 8GHz to 18GHz

Frequency (MHz)	MaxPeak (dB μ V/m)	Average (dB μ V/m)	Limit (dB μ V/m)	Margin (dB)	Meas. Time (ms)	Height (cm)	Pol	Azimuth (deg)	Corr. (dB/m)
1267.75	44.71	---	68.20	23.49	500.00	100.0	V	289.00	-2
1372.75	---	33.44	54.00	20.56	500.00	200.0	V	67.00	-1
1719.25	---	34.01	54.00	19.99	500.00	200.0	V	0.00	0
1980.00	46.36	---	68.20	21.84	500.00	200.0	V	94.00	1
2678.25	49.16	---	68.20	19.04	500.00	200.0	V	4.00	4
2809.50	---	38.25	54.00	15.75	500.00	100.0	V	346.00	4
3321.38	51.87	---	68.20	16.33	500.00	100.0	V	357.00	5
3999.50	---	41.63	54.00	12.37	500.00	100.0	V	263.00	6
5459.88	---	49.52	54.00	4.48	500.00	200.0	V	141.00	11
5469.50	64.33	---	68.20	3.87	500.00	100.0	V	359.00	11
7675.38	---	50.13	54.00	3.87	500.00	200.0	V	101.00	17
7903.75	63.55	---	68.20	4.65	500.00	200.0	V	115.00	17
17771.25	---	48.54	54.00	5.46	500.00	100.0	V	0.00	11

Remark: 1. Correction Factor = Antenna factor + Insertion loss (cable loss + amplifier gain)

2. Margin = Limit - MAX Peak/ Average

802.11a CH120

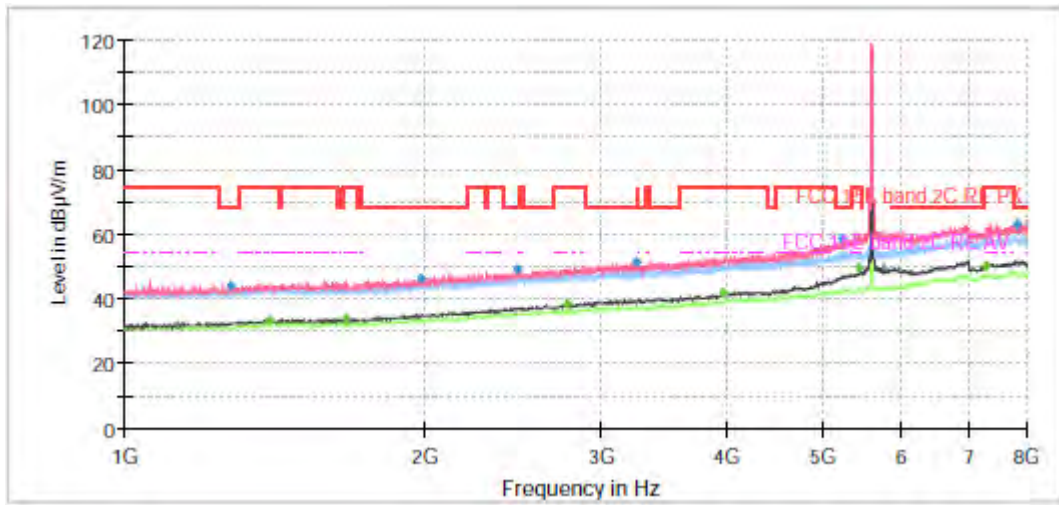

Note: The signal beyond the limit is carrier.
Radiates Emission from 1GHz to 8GHz

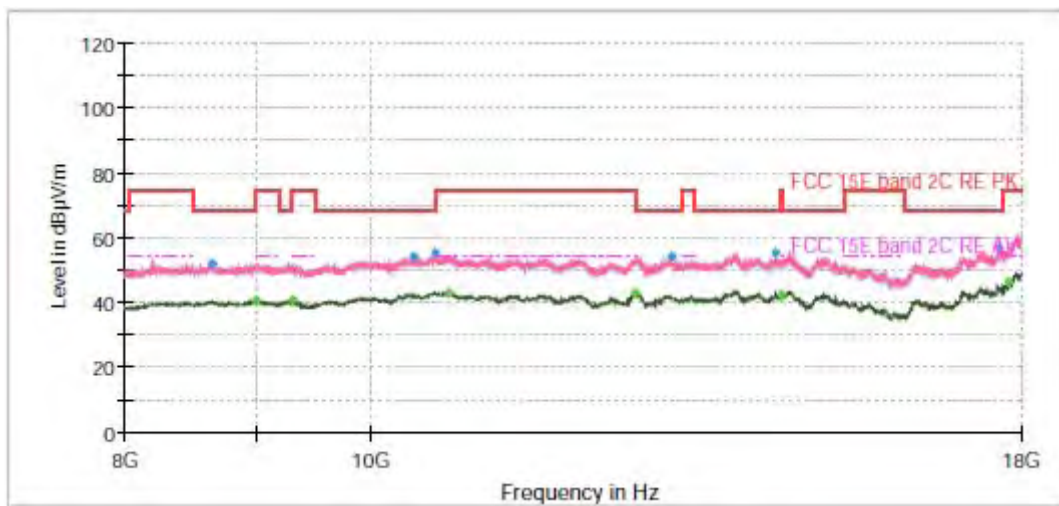

Radiates Emission from 8GHz to 18GHz

Frequency (MHz)	MaxPeak (dB μ V/m)	Average (dB μ V/m)	Limit (dB μ V/m)	Margin (dB)	Meas. Time (ms)	Height (cm)	Pol	Azimuth (deg)	Corr. (dB/m)
1277.38	44.01	---	68.20	24.19	500.00	100.0	V	348.00	-2
1394.63	---	33.59	54.00	20.41	500.00	200.0	V	113.00	-1
1661.50	---	33.87	54.00	20.13	500.00	100.0	V	298.00	-1
1980.00	46.11	---	68.20	22.09	500.00	100.0	V	129.00	1
2466.50	49.29	---	68.20	18.91	500.00	200.0	V	0.00	3
2770.13	---	38.30	54.00	15.70	500.00	100.0	V	0.00	4
3248.75	51.43	---	68.20	16.77	500.00	200.0	V	59.00	5
3978.50	---	41.74	54.00	12.26	500.00	200.0	V	186.00	6
5221.00	58.56	---	68.20	9.64	500.00	200.0	V	26.00	10
5441.50	---	49.85	54.00	4.15	500.00	200.0	V	140.00	11
7298.25	---	50.08	54.00	3.92	500.00	100.0	V	358.00	15
7836.38	63.14	---	68.20	5.06	500.00	200.0	V	0.00	17

Remark: 1. Correction Factor = Antenna factor + Insertion loss (cable loss + amplifier gain)

2. Margin = Limit –MAX Peak/ Average

802.11a CH140

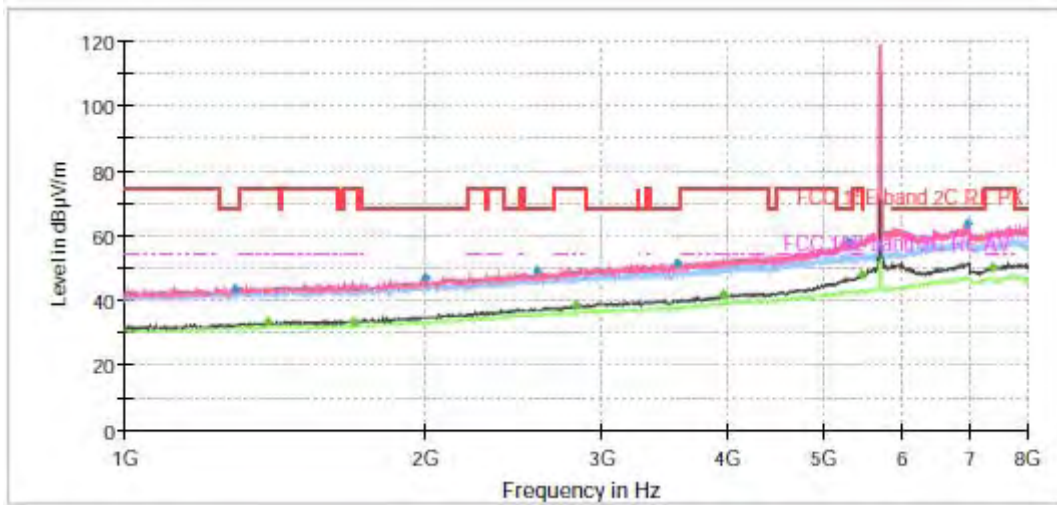

Note: The signal beyond the limit is carrier.
Radiates Emission from 1GHz to 8GHz

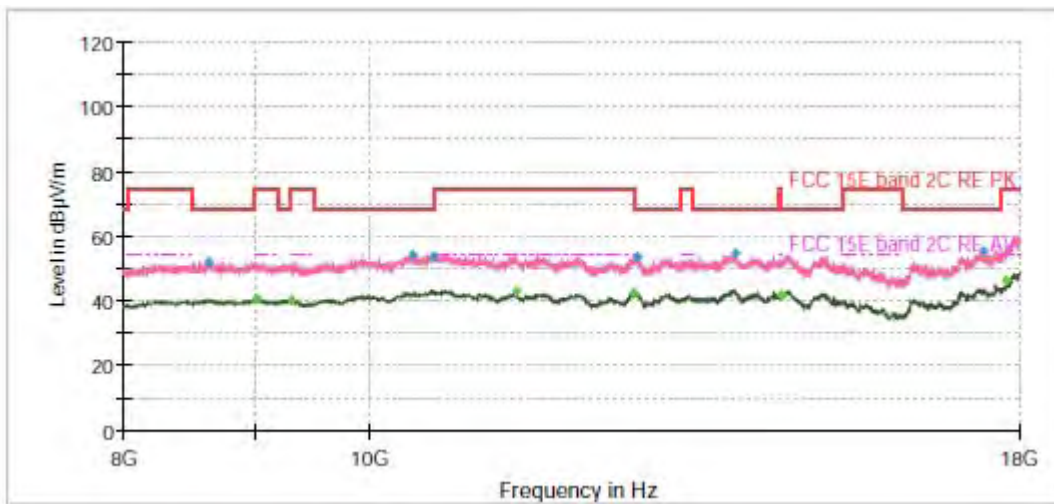

Radiates Emission from 8GHz to 18GHz

Frequency (MHz)	MaxPeak (dB μ V/m)	Average (dB μ V/m)	Limit (dB μ V/m)	Margin (dB)	Meas. Time (ms)	Height (cm)	Pol	Azimuth (deg)	Corr. (dB/m)
1287.00	43.78	---	68.20	24.42	500.00	100.0	V	0.00	-2
1386.75	---	33.34	54.00	20.66	500.00	100.0	V	0.00	-1
1693.88	---	33.72	54.00	20.28	500.00	100.0	V	211.00	-1
1994.88	46.73	---	68.20	21.47	500.00	100.0	V	118.00	1
2588.13	48.92	---	68.20	19.28	500.00	100.0	V	205.00	3
2823.50	---	38.40	54.00	15.60	500.00	200.0	V	71.00	4
3572.50	51.34	---	68.20	16.86	500.00	200.0	V	171.00	5
3977.63	---	41.70	54.00	12.30	500.00	100.0	V	356.00	6
5301.50	58.00	---	68.20	10.20	500.00	100.0	V	351.00	11
5453.75	---	47.95	54.00	6.05	500.00	100.0	V	351.00	11
6958.75	63.55	---	68.20	4.65	500.00	200.0	V	9.00	14
7395.38	---	50.05	54.00	3.95	500.00	100.0	V	284.00	16

Remark: 1. Correction Factor = Antenna factor + Insertion loss (cable loss + amplifier gain)

2. Margin = Limit –MAX Peak/ Average

802.11a CH144

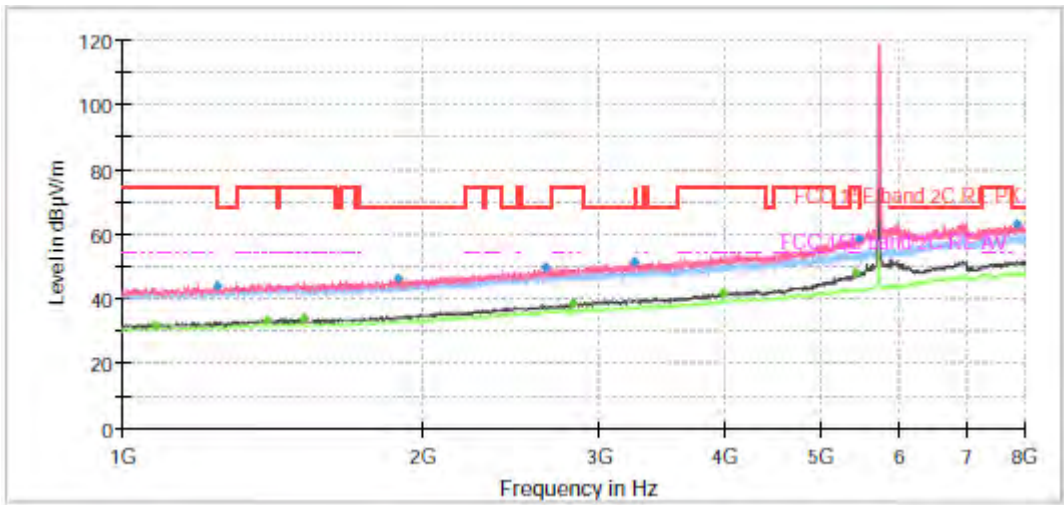

Note: The signal beyond the limit is carrier.
Radiates Emission from 1GHz to 8GHz

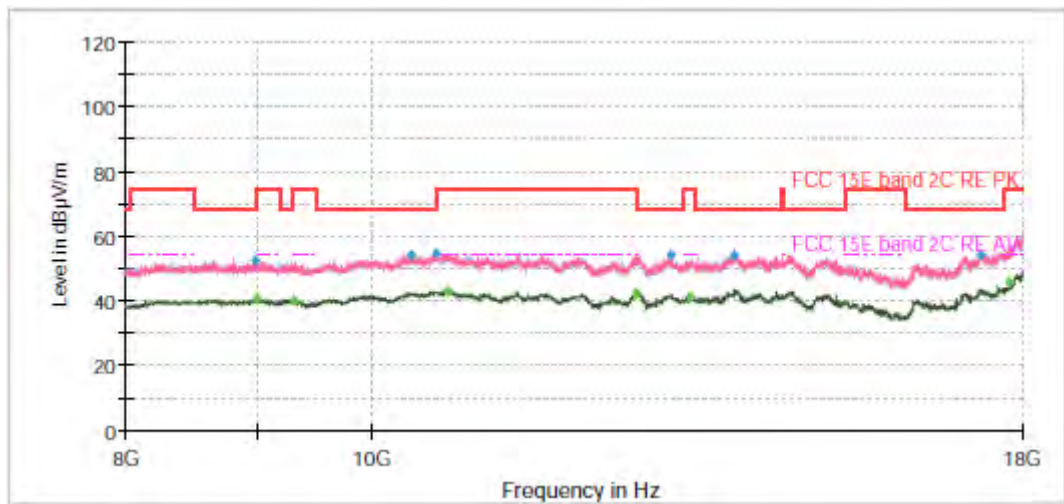

Radiates Emission from 8GHz to 18GHz

Frequency (MHz)	MaxPeak (dB μ V/m)	Average (dB μ V/m)	Limit (dB μ V/m)	Margin (dB)	Meas. Time (ms)	Height (cm)	Pol	Azimuth (deg)	Corr. (dB/m)
1079.63	---	31.86	54.00	22.14	500.00	100.0	V	152.00	-2
1242.38	44.08	---	68.20	24.12	500.00	200.0	V	233.00	-2
1392.88	---	33.47	54.00	20.53	500.00	100.0	V	199.00	-1
1516.25	---	33.84	54.00	20.16	500.00	200.0	V	170.00	-1
1881.13	46.44	---	68.20	21.76	500.00	100.0	V	285.00	0
2646.75	49.45	---	68.20	18.75	500.00	100.0	V	326.00	4
2823.50	---	38.31	54.00	15.69	500.00	200.0	V	75.00	4
3247.88	51.51	---	68.20	16.69	500.00	100.0	V	239.00	5
3989.00	---	41.59	54.00	12.41	500.00	200.0	V	186.00	6
5426.63	---	48.02	54.00	5.98	500.00	200.0	V	43.00	11
5462.50	58.68	---	68.20	9.52	500.00	200.0	V	55.00	11
7857.38	63.29	---	68.20	4.91	500.00	100.0	V	232.00	17

Remark: 1. Correction Factor = Antenna factor + Insertion loss (cable loss + amplifier gain)

2. Margin = Limit –MAX Peak/ Average

802.11a CH149

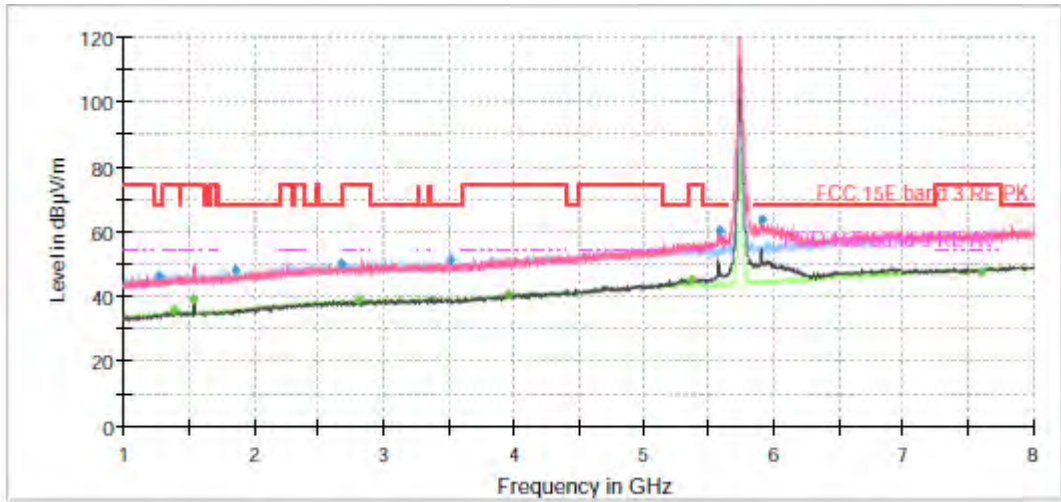

Note: The signal beyond the limit is carrier.
Radiates Emission from 1GHz to 8GHz

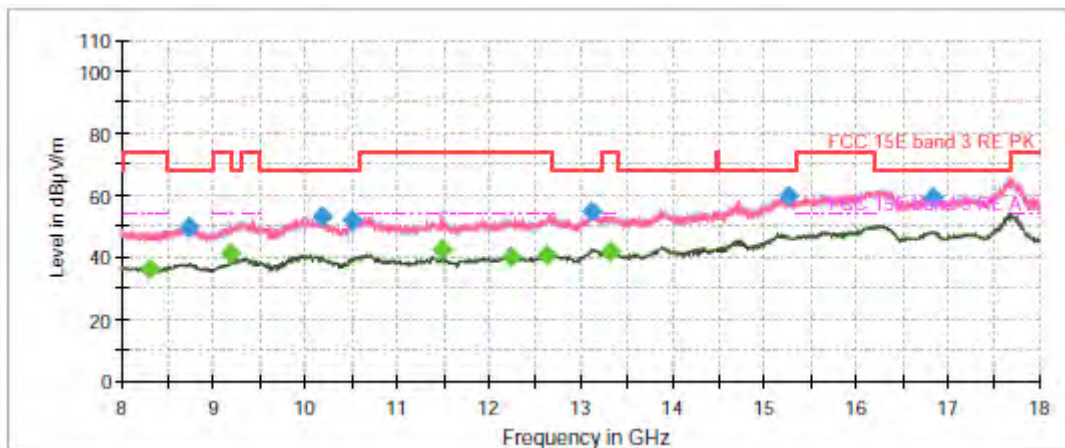

Radiates Emission from 8GHz to 18GHz

Frequency (MHz)	MaxPeak (dB μ V/m)	Average (dB μ V/m)	Limit (dB μ V/m)	Margin (dB)	Meas. Time (ms)	Height (cm)	Pol	Azimuth (deg)	Corr. (dB/m)
1269.50	46.16	---	68.20	22.04	500.00	200.0	H	193.00	-10
1390.25	---	35.54	54.00	18.46	500.00	100.0	H	57.00	-9
1539.00	---	39.22	54.00	14.78	500.00	200.0	V	142.00	-9
1854.88	47.99	---	68.20	20.21	500.00	100.0	V	257.00	-8
2673.00	50.06	---	68.20	18.14	500.00	200.0	H	261.00	-6
2810.38	---	39.01	54.00	14.99	500.00	200.0	H	295.00	-5
3515.63	51.23	---	68.20	16.97	500.00	100.0	V	222.00	-4
3956.63	---	40.59	54.00	13.41	500.00	200.0	H	210.00	-2
5365.38	---	45.46	54.00	8.54	500.00	100.0	V	170.00	3
5591.13	60.26	---	68.20	7.94	500.00	200.0	V	4.00	3
5907.88	63.74	---	68.20	4.46	500.00	200.0	V	347.00	4
7604.50	---	47.64	54.00	6.36	500.00	200.0	V	0.00	8

Remark: 1. Correction Factor = Antenna factor + Insertion loss (cable loss + amplifier gain)

2. Margin = Limit –MAX Peak/ Average

802.11a CH157

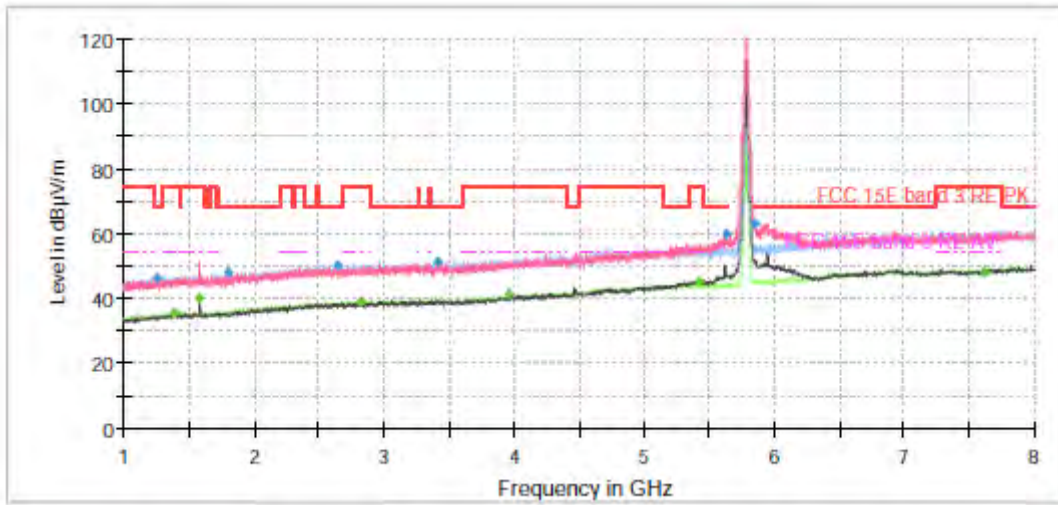

Note: The signal beyond the limit is carrier.
Radiates Emission from 1GHz to 8GHz

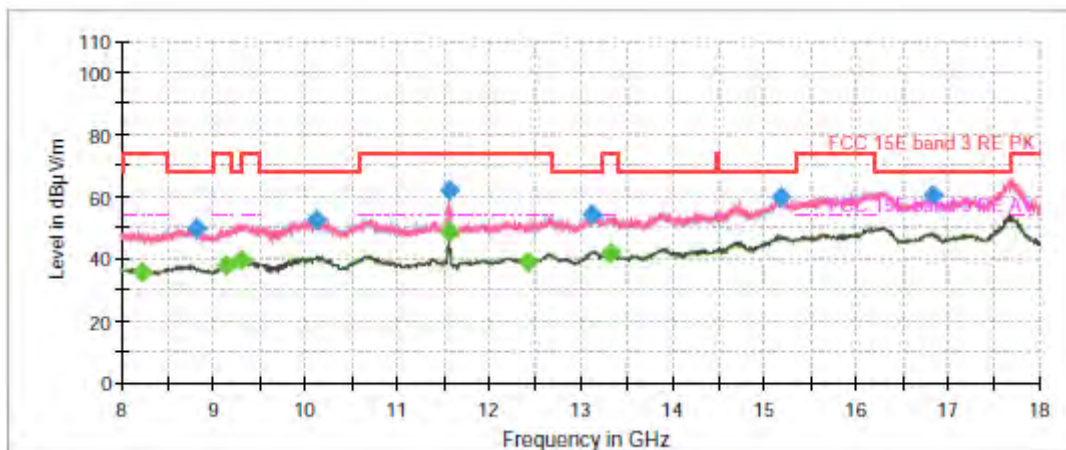

Radiates Emission from 8GHz to 18GHz

Frequency (MHz)	MaxPeak (dB μ V/m)	Average (dB μ V/m)	Limit (dB μ V/m)	Margin (dB)	Meas. Time (ms)	Height (cm)	Pol	Azimuth (deg)	Corr. (dB/m)
1258.13	46.29	---	68.20	21.91	500.00	100.0	V	322.00	-10
1379.75	---	35.73	54.00	18.27	500.00	200.0	H	345.00	-9
1580.13	---	40.37	54.00	13.63	500.00	200.0	V	2.00	-9
1791.88	48.02	---	68.20	20.18	500.00	200.0	H	291.00	-8
2637.13	50.08	---	68.20	18.12	500.00	200.0	H	358.00	-6
2815.63	---	39.06	54.00	14.94	500.00	200.0	H	0.00	-5
3408.88	51.31	---	68.20	16.89	500.00	100.0	H	183.00	-4
3965.38	---	41.13	54.00	12.87	500.00	200.0	H	282.00	-2
5430.13	---	45.40	54.00	8.60	500.00	100.0	V	48.00	3
5627.00	59.52	---	68.20	8.68	500.00	200.0	V	180.00	3
5853.63	63.34	---	68.20	4.86	500.00	200.0	V	1.00	4
7612.38	---	48.11	54.00	5.89	500.00	200.0	H	358.00	8

Remark: 1. Correction Factor = Antenna factor + Insertion loss (cable loss + amplifier gain)

2. Margin = Limit - MAX Peak/ Average

802.11a CH165

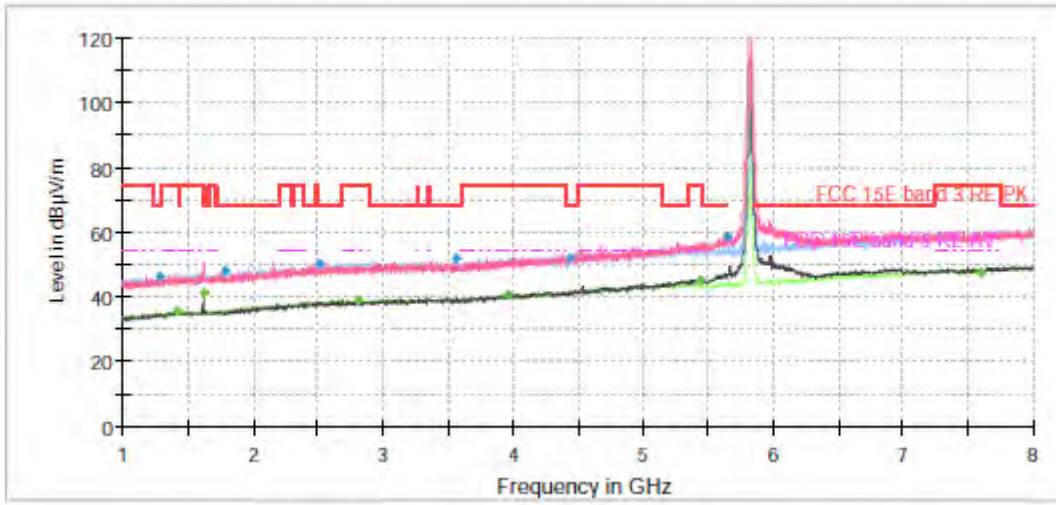

Note: The signal beyond the limit is carrier.
Radiates Emission from 1GHz to 8GHz

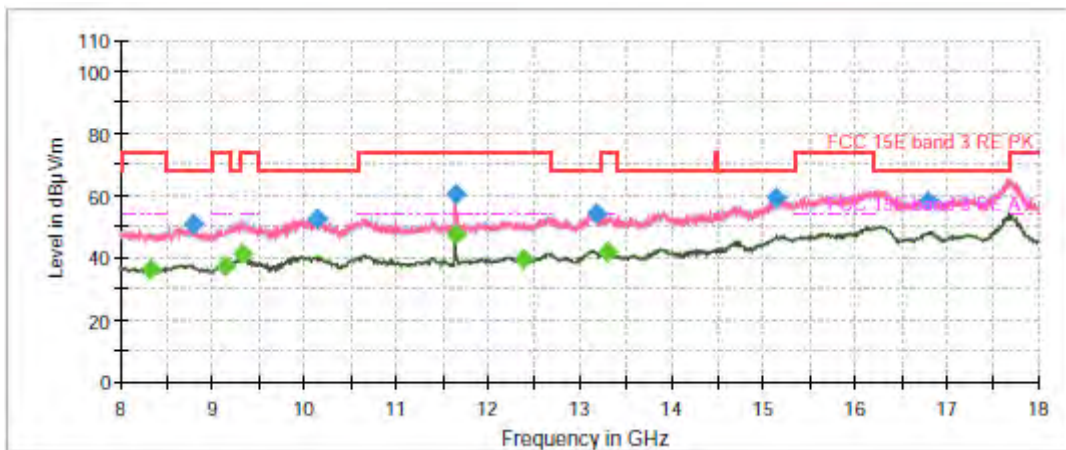

Radiates Emission from 8GHz to 18GHz

Frequency (MHz)	MaxPeak (dB μ V/m)	Average (dB μ V/m)	Limit (dB μ V/m)	Margin (dB)	Meas. Time (ms)	Height (cm)	Pol	Azimuth (deg)	Corr. (dB/m)
1273.88	46.32	---	68.20	21.88	500.00	200.0	H	357.00	-10
1411.25	---	35.73	54.00	18.27	500.00	100.0	V	356.00	-9
1619.50	---	41.04	54.00	12.96	500.00	200.0	V	0.00	-9
1780.50	48.15	---	68.20	20.05	500.00	200.0	H	166.00	-8
2510.25	50.27	---	68.20	17.93	500.00	100.0	H	67.00	-6
2805.13	---	39.01	54.00	14.99	500.00	100.0	H	153.00	-5
3554.13	51.72	---	68.20	16.48	500.00	200.0	H	359.00	-4
3961.00	---	40.79	54.00	13.21	500.00	200.0	V	34.00	-2
4432.63	51.71	---	68.20	16.49	500.00	100.0	H	127.00	-1
5446.75	---	45.45	54.00	8.55	500.00	100.0	V	121.00	3
5642.75	58.42	---	68.20	9.78	500.00	200.0	V	0.00	3
7596.63	---	47.60	54.00	6.40	500.00	100.0	H	204.00	8

Remark: 1. Correction Factor = Antenna factor + Insertion loss (cable loss + amplifier gain)

2. Margin = Limit –MAX Peak/ Average

802.11n (HT20) CH36

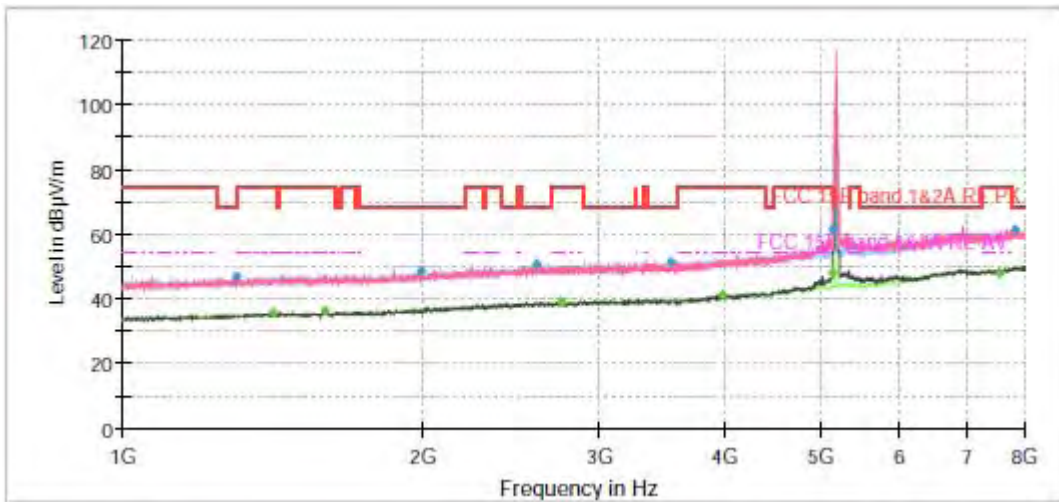

Note: The signal beyond the limit is carrier.
Radiates Emission from 1GHz to 8GHz

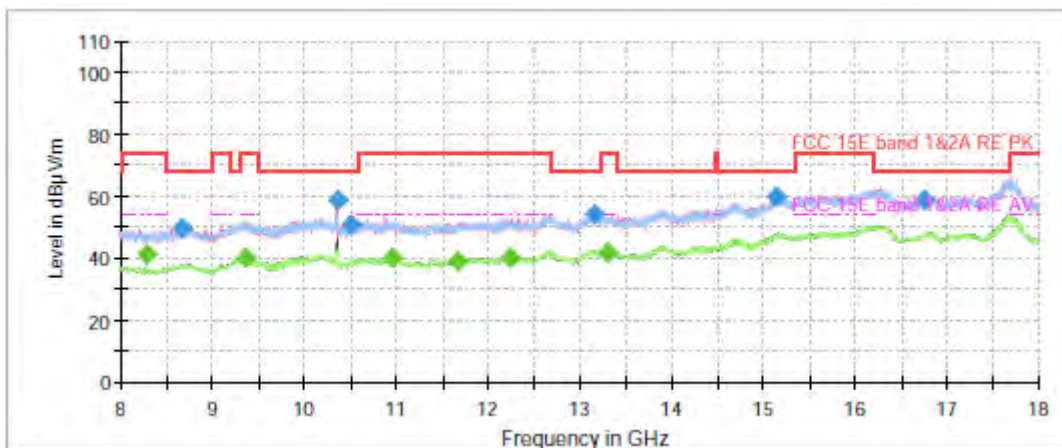

Radiates Emission from 8GHz to 18GHz

Frequency (MHz)	MaxPeak (dB μ V/m)	Average (dB μ V/m)	Limit (dB μ V/m)	Margin (dB)	Meas. Time (ms)	Height (cm)	Pol	Azimuth (deg)	Corr. (dB/m)
1297.50	46.67	---	68.20	21.53	500.00	100.0	H	2.00	-9
1412.13	---	35.72	54.00	18.28	500.00	100.0	V	243.00	-9
1592.38	---	36.09	54.00	17.91	500.00	200.0	V	16.00	-9
1991.38	48.34	---	68.20	19.86	500.00	100.0	H	4.00	-7
2591.63	51.03	---	68.20	17.17	500.00	200.0	H	335.00	-6
2750.88	---	39.32	54.00	14.68	500.00	100.0	V	116.00	-5
3531.38	51.62	---	68.20	16.58	500.00	200.0	H	0.00	-4
3991.63	---	41.11	54.00	12.89	500.00	100.0	V	223.00	-2
5133.50	---	47.72	54.00	6.28	500.00	200.0	V	6.00	2
5134.38	61.30	---	74.00	12.70	500.00	200.0	V	6.00	2
7536.25	---	48.09	54.00	5.91	500.00	200.0	V	34.00	8
7825.88	61.24	---	68.20	6.96	500.00	100.0	V	243.00	9

Remark: 1. Correction Factor = Antenna factor + Insertion loss (cable loss + amplifier gain)

2. Margin = Limit –MAX Peak/ Average

802.11n (HT20) CH40

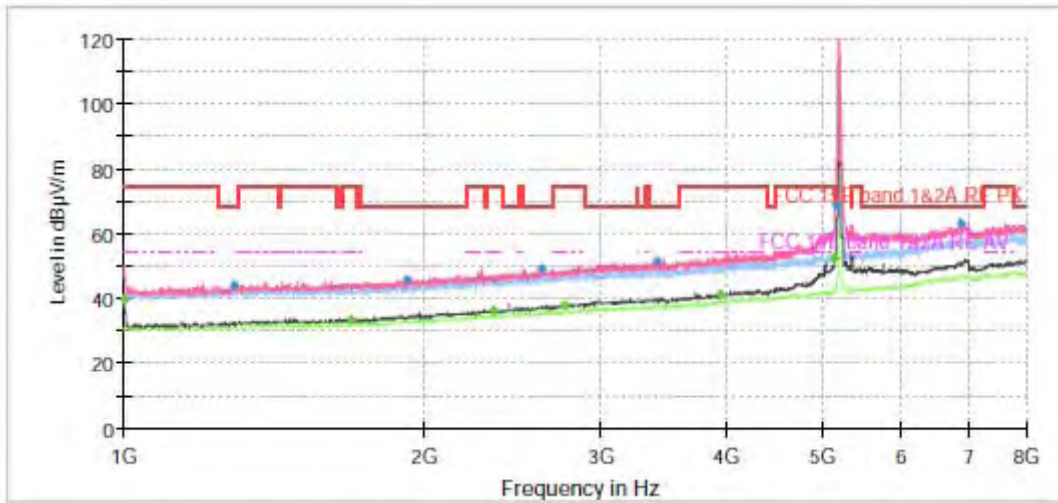

Note: The signal beyond the limit is carrier.
Radiates Emission from 1GHz to 8GHz

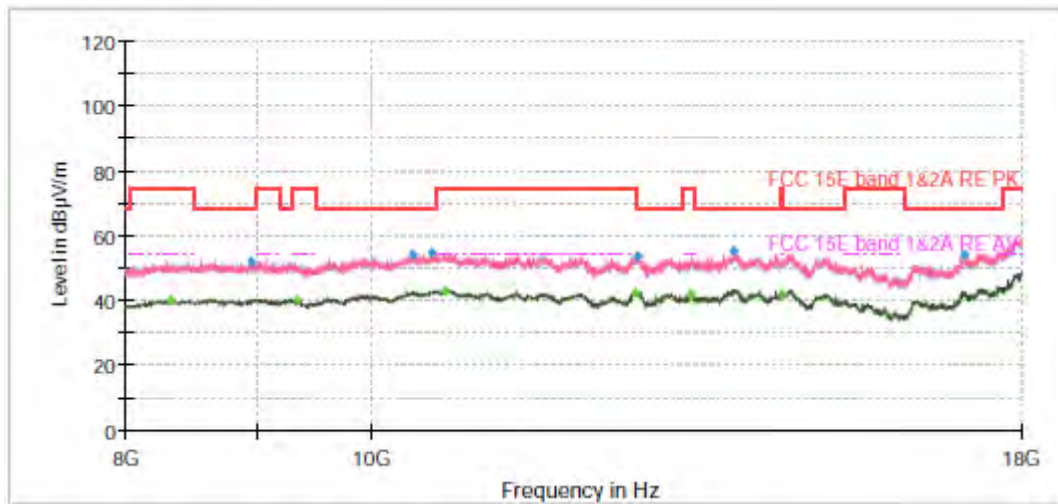

Radiates Emission from 8GHz to 18GHz

Frequency (MHz)	MaxPeak (dB μ V/m)	Average (dB μ V/m)	Limit (dB μ V/m)	Margin (dB)	Meas. Time (ms)	Height (cm)	Pol	Azimuth (deg)	Corr. (dB/m)
1000.00	---	39.41	54.00	14.59	500.00	100.0	V	9.00	-3
1289.63	44.24	---	68.20	23.96	500.00	200.0	V	104.00	-2
1690.38	---	33.68	54.00	20.32	500.00	100.0	V	74.00	-1
1921.38	45.99	---	68.20	22.21	500.00	100.0	V	0.00	0
2347.50	---	36.07	54.00	17.93	500.00	100.0	V	0.00	2
2618.75	49.24	---	68.20	18.96	500.00	100.0	V	229.00	4
2764.88	---	38.10	54.00	15.90	500.00	200.0	V	70.00	4
3419.38	51.37	---	68.20	16.83	500.00	100.0	V	61.00	5
3960.13	---	41.53	54.00	12.47	500.00	200.0	V	0.00	6
5145.75	---	52.66	54.00	1.34	500.00	200.0	V	185.00	10
5149.25	68.86	---	74.00	5.14	500.00	100.0	V	354.00	10
6876.50	63.34	---	68.20	4.86	500.00	100.0	V	257.00	13

Remark: 1. Correction Factor = Antenna factor + Insertion loss (cable loss + amplifier gain)

2. Margin = Limit –MAX Peak/ Average

802.11n (HT20) CH48

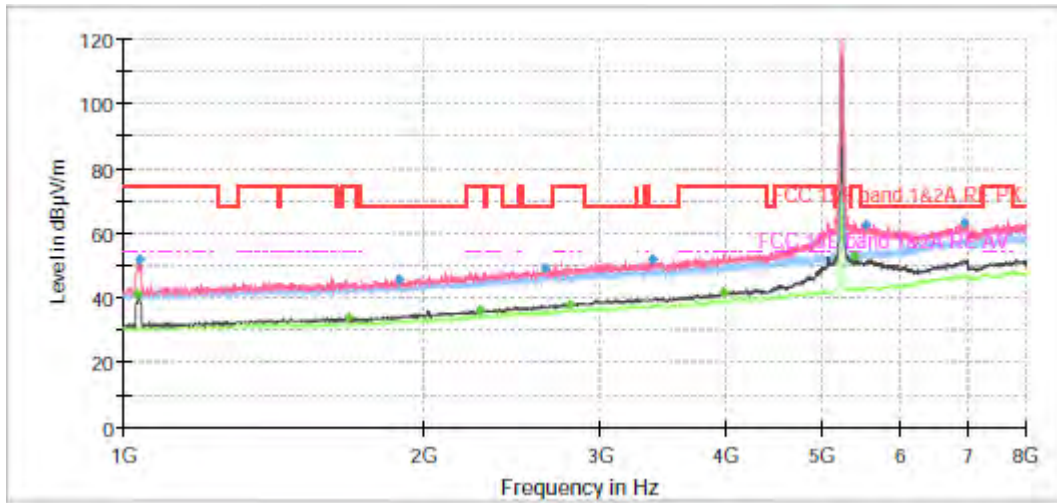

Note: The signal beyond the limit is carrier.
Radiates Emission from 1GHz to 8GHz

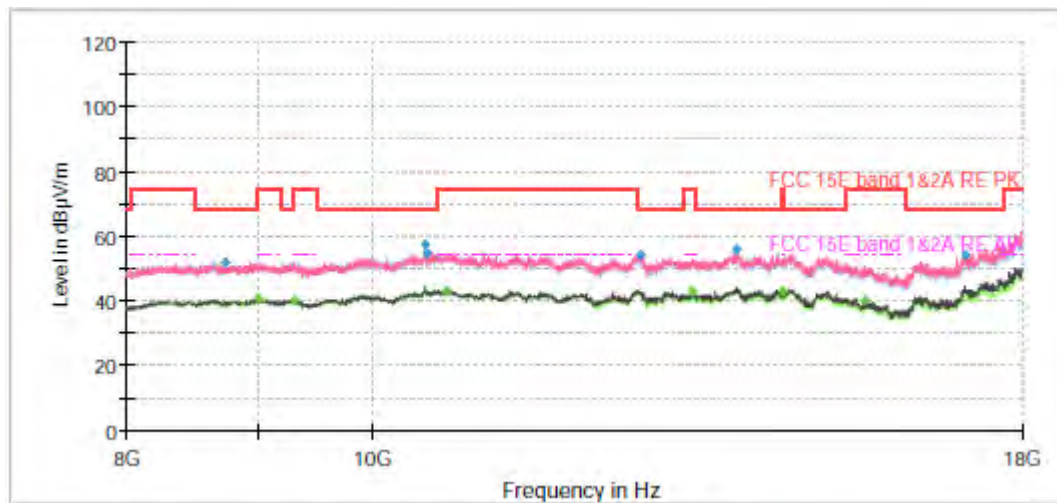

Radiates Emission from 8GHz to 18GHz

Frequency (MHz)	MaxPeak (dB μ V/m)	Average (dB μ V/m)	Limit (dB μ V/m)	Margin (dB)	Meas. Time (ms)	Height (cm)	Pol	Azimuth (deg)	Corr. (dB/m)
1033.25	---	41.37	54.00	12.63	500.00	200.0	V	170.00	-3
1034.13	51.97	---	74.00	22.03	500.00	200.0	V	177.00	-3
1679.88	---	33.84	54.00	20.16	500.00	200.0	V	245.00	-1
1888.13	45.84	---	68.20	22.36	500.00	200.0	V	262.00	0
2266.13	---	36.26	54.00	17.74	500.00	200.0	V	0.00	2
2638.88	49.05	---	68.20	19.15	500.00	100.0	V	33.00	4
2800.75	---	38.20	54.00	15.80	500.00	100.0	V	60.00	4
3387.00	51.78	---	68.20	16.42	500.00	200.0	V	314.00	5
3992.50	---	41.62	54.00	12.38	500.00	100.0	V	108.00	6
5394.25	---	53.10	54.00	0.90	500.00	200.0	V	184.00	11
5529.88	62.28	---	68.20	5.92	500.00	200.0	V	170.00	11
6952.63	63.24	---	68.20	4.96	500.00	200.0	V	224.00	14

Remark: 1. Correction Factor = Antenna factor + Insertion loss (cable loss + amplifier gain)

2. Margin = Limit –MAX Peak/ Average

802.11n (HT20) CH52

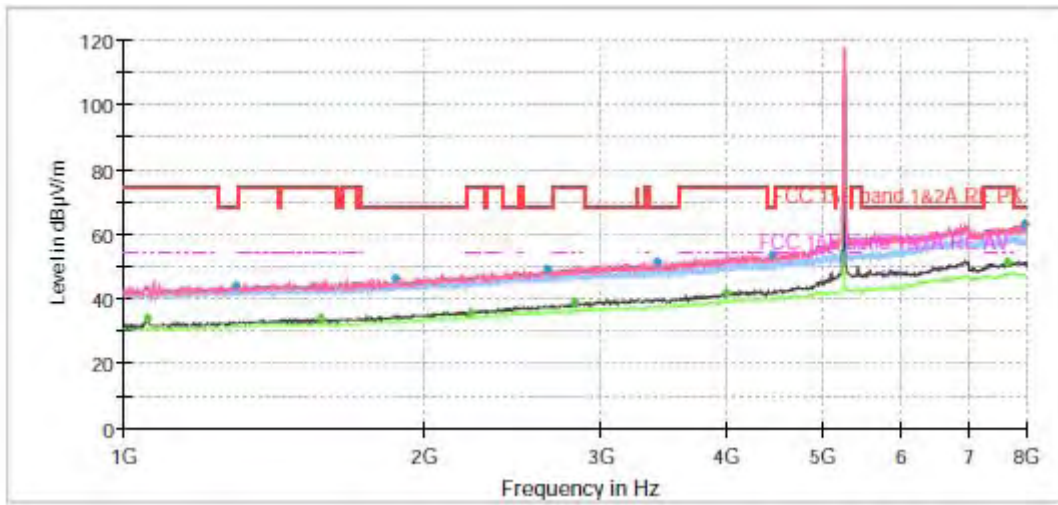

Note: The signal beyond the limit is carrier.
Radiates Emission from 1GHz to 8GHz

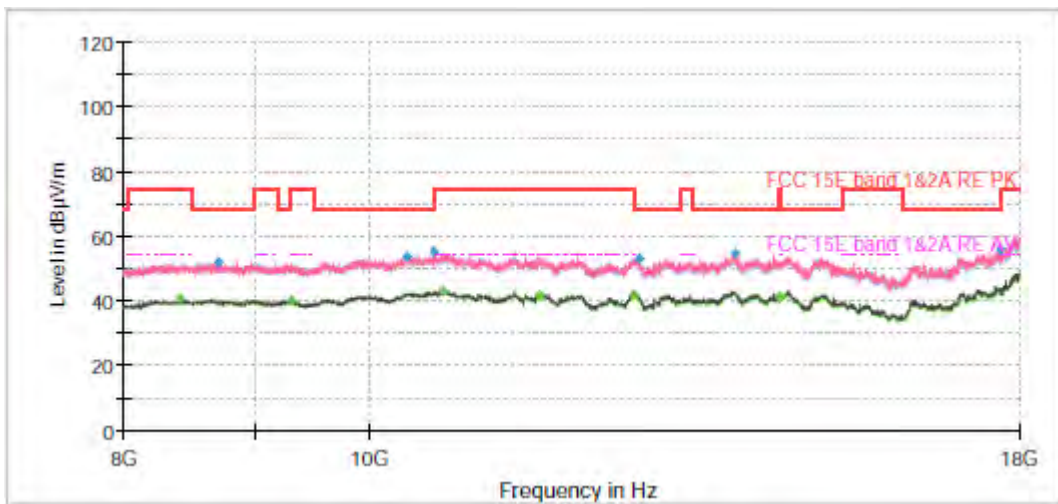

Radiates Emission from 8GHz to 18GHz

Frequency (MHz)	MaxPeak (dB μ V/m)	Average (dB μ V/m)	Limit (dB μ V/m)	Margin (dB)	Meas. Time (ms)	Height (cm)	Pol	Azimuth (deg)	Corr. (dB/m)
1056.88	---	34.08	54.00	19.92	500.00	200.0	V	169.00	-3
1295.75	44.09	---	68.20	24.11	500.00	100.0	V	158.00	-1
1568.75	---	34.03	54.00	19.97	500.00	100.0	V	110.00	-1
1867.13	46.26	---	68.20	21.94	500.00	200.0	V	182.00	0
2224.13	---	35.62	54.00	18.38	500.00	100.0	V	0.00	2
2651.13	49.30	---	68.20	18.90	500.00	100.0	V	279.00	4
2827.88	---	38.82	54.00	15.18	500.00	100.0	V	292.00	4
3412.38	51.59	---	68.20	16.61	500.00	100.0	V	356.00	5
3999.50	---	41.61	54.00	12.39	500.00	100.0	V	0.00	6
4458.88	53.53	---	68.20	14.67	500.00	100.0	V	144.00	7
7659.63	---	51.19	54.00	2.81	500.00	200.0	V	0.00	17
7958.00	63.00	---	68.20	5.20	500.00	200.0	V	47.00	17

Remark: 1. Correction Factor = Antenna factor + Insertion loss (cable loss + amplifier gain)

2. Margin = Limit –MAX Peak/ Average

802.11n (HT20) CH60

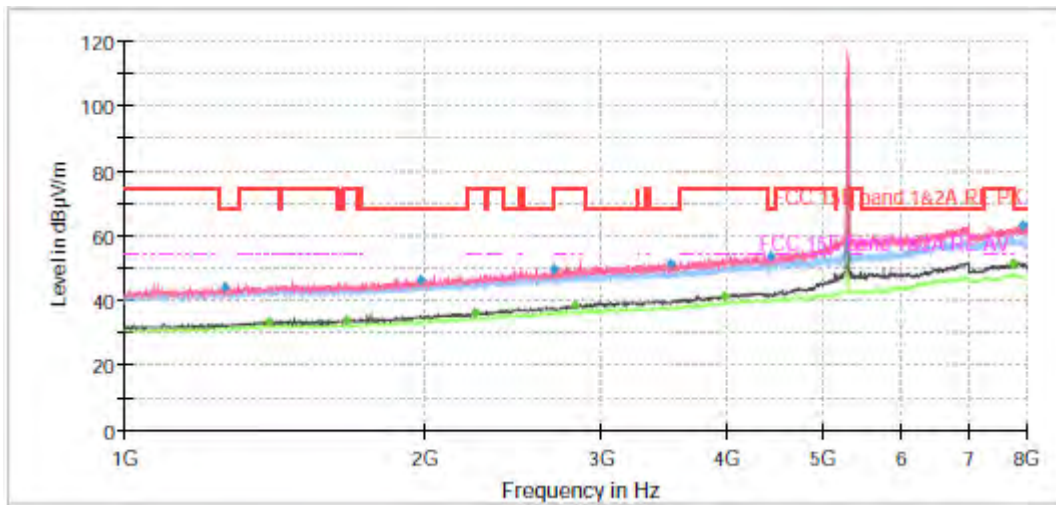

Note: The signal beyond the limit is carrier.
Radiates Emission from 1GHz to 8GHz

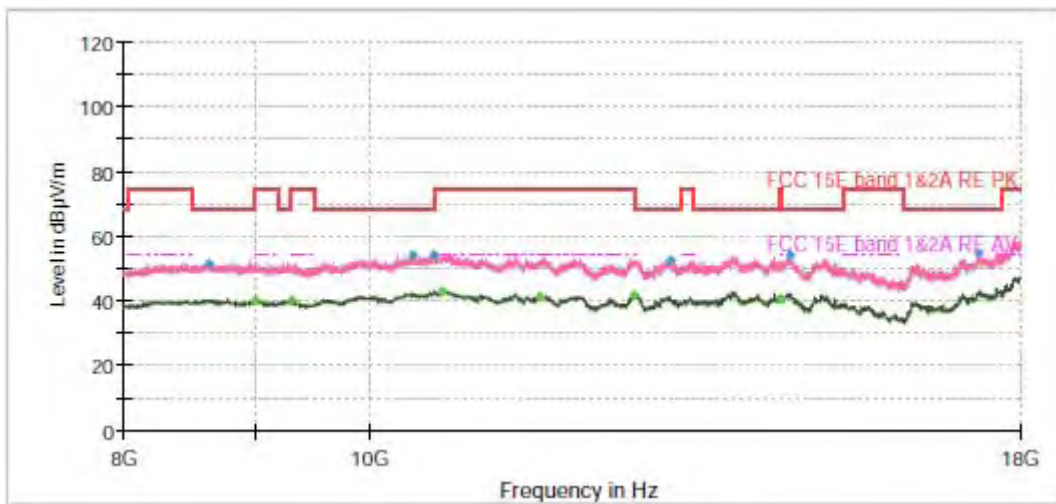

Radiates Emission from 8GHz to 18GHz

Frequency (MHz)	MaxPeak (dB μ V/m)	Average (dB μ V/m)	Limit (dB μ V/m)	Margin (dB)	Meas. Time (ms)	Height (cm)	Pol	Azimuth (deg)	Corr. (dB/m)
1260.75	44.28	---	68.20	23.92	500.00	100.0	V	190.00	-2
1392.00	---	33.43	54.00	20.57	500.00	100.0	V	302.00	-1
1663.25	---	34.04	54.00	19.96	500.00	200.0	V	167.00	-1
1980.88	46.14	---	68.20	22.06	500.00	100.0	V	256.00	1
2245.13	---	36.24	54.00	17.76	500.00	100.0	V	142.00	2
2683.50	49.83	---	68.20	18.37	500.00	100.0	V	358.00	4
2820.88	---	38.65	54.00	15.35	500.00	200.0	V	72.00	4
3526.13	51.57	---	68.20	16.63	500.00	100.0	V	295.00	5
3994.25	---	41.55	54.00	12.45	500.00	100.0	V	91.00	6
4430.88	53.70	---	68.20	14.50	500.00	200.0	V	53.00	6
7741.88	---	51.14	54.00	2.86	500.00	100.0	V	0.00	17
7942.25	63.06	---	68.20	5.14	500.00	100.0	V	169.00	17

Remark: 1. Correction Factor = Antenna factor + Insertion loss (cable loss + amplifier gain)

2. Margin = Limit –MAX Peak/ Average

802.11n (HT20) CH64

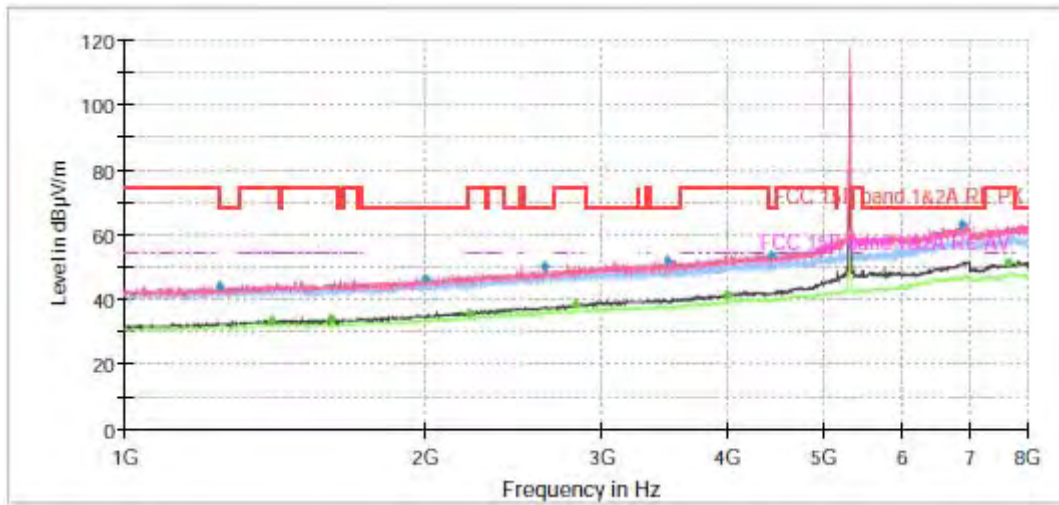

Note: The signal beyond the limit is carrier.
Radiates Emission from 1GHz to 8GHz

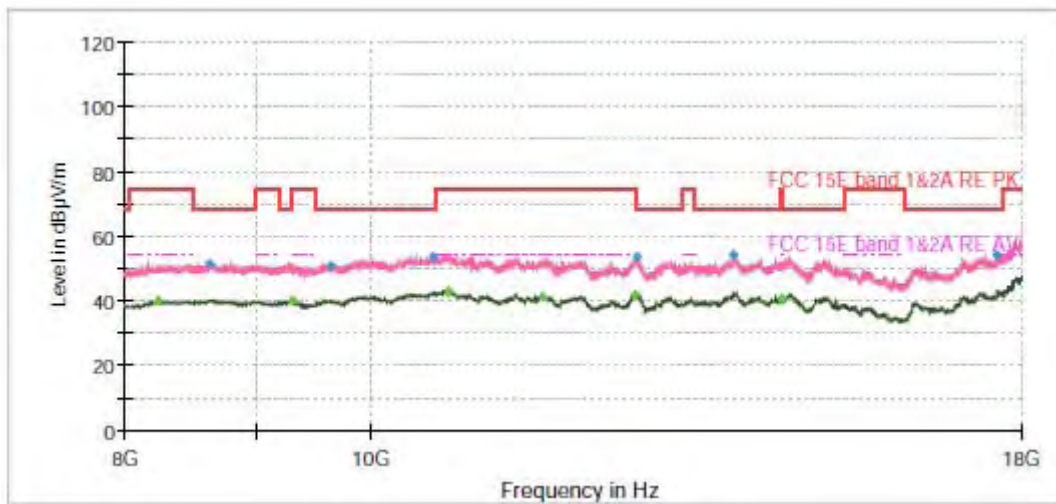

Radiates Emission from 8GHz to 18GHz

Frequency (MHz)	MaxPeak (dB μ V/m)	Average (dB μ V/m)	Limit (dB μ V/m)	Margin (dB)	Meas. Time (ms)	Height (cm)	Pol	Azimuth (deg)	Corr. (dB/m)
1242.38	43.83	---	68.20	24.37	500.00	200.0	V	21.00	-2
1401.63	---	33.64	54.00	20.36	500.00	200.0	V	21.00	-1
1604.63	---	34.01	54.00	19.99	500.00	100.0	V	347.00	-1
1999.25	46.40	---	68.20	21.80	500.00	200.0	V	298.00	1
2214.50	---	35.61	54.00	18.39	500.00	200.0	V	0.00	2
2628.38	50.08	---	68.20	18.12	500.00	200.0	V	216.00	4
2826.13	---	38.37	54.00	15.63	500.00	200.0	V	4.00	4
3484.13	51.80	---	68.20	16.40	500.00	200.0	V	0.00	5
3999.50	---	41.53	54.00	12.47	500.00	200.0	V	0.00	6
4430.88	53.57	---	68.20	14.63	500.00	100.0	V	296.00	6
6875.63	63.15	---	68.20	5.05	500.00	100.0	V	48.00	13
7656.13	---	51.12	54.00	2.88	500.00	100.0	V	356.00	17

Remark: 1. Correction Factor = Antenna factor + Insertion loss (cable loss + amplifier gain)

2. Margin = Limit –MAX Peak/ Average

802.11n (HT20) CH100

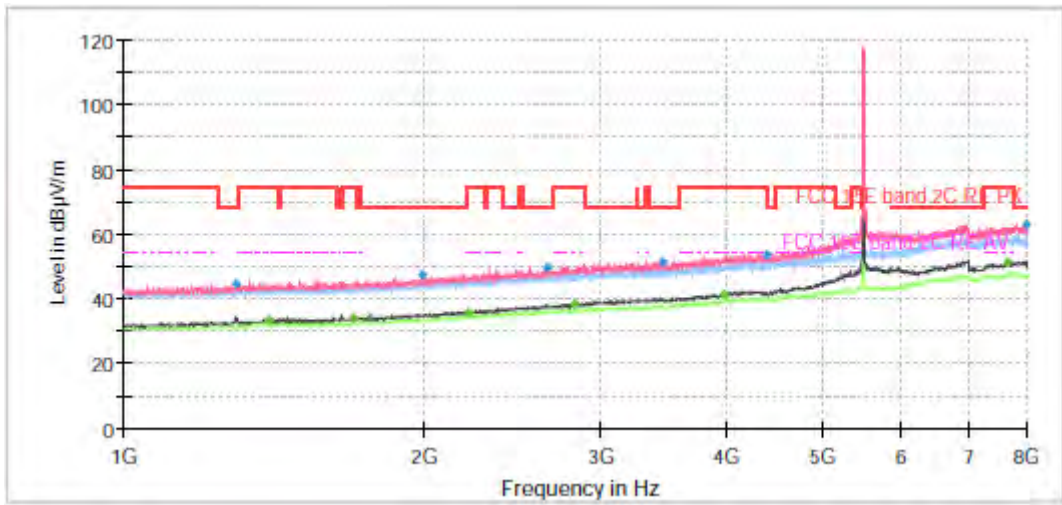

Note: The signal beyond the limit is carrier.
Radiates Emission from 1GHz to 8GHz

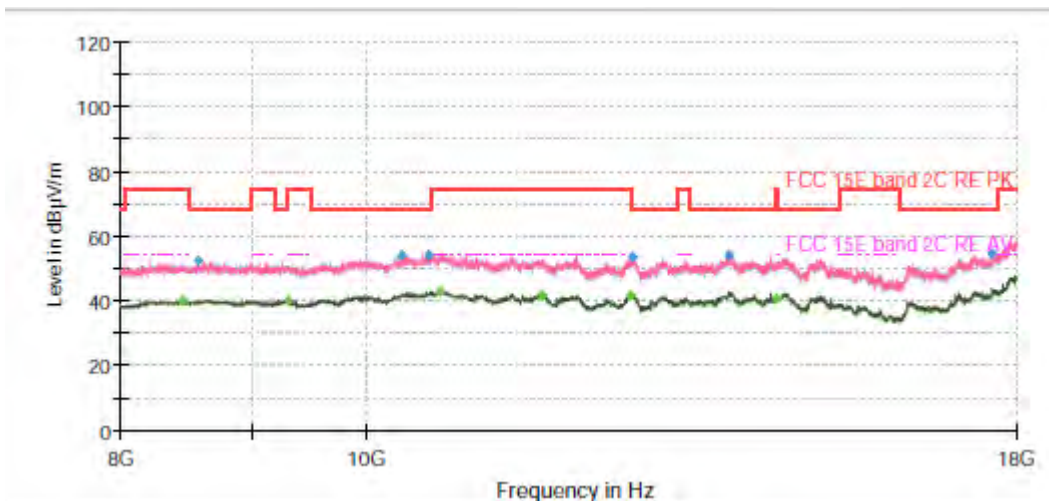

Radiates Emission from 8GHz to 18GHz

Frequency (MHz)	MaxPeak (dB μ V/m)	Average (dB μ V/m)	Limit (dB μ V/m)	Margin (dB)	Meas. Time (ms)	Height (cm)	Pol	Azimuth (deg)	Corr. (dB/m)
1291.38	44.60	---	68.20	23.60	500.00	200.0	V	73.00	-2
1397.25	---	33.53	54.00	20.47	500.00	100.0	V	334.00	-1
1693.88	---	33.98	54.00	20.02	500.00	200.0	V	4.00	-1
1987.88	47.47	---	68.20	20.73	500.00	100.0	V	327.00	1
2209.25	---	35.65	54.00	18.35	500.00	200.0	V	106.00	2
2654.63	49.64	---	68.20	18.56	500.00	200.0	V	208.00	4
2827.88	---	38.49	54.00	15.51	500.00	200.0	V	208.00	4
3454.38	51.46	---	68.20	16.74	500.00	100.0	V	327.00	5
3996.00	---	41.46	54.00	12.54	500.00	100.0	V	82.00	6
4402.88	53.80	---	68.20	14.40	500.00	200.0	V	194.00	6
7655.25	---	51.19	54.00	2.81	500.00	200.0	V	10.00	17
7996.50	63.26	---	68.20	4.94	500.00	200.0	V	33.00	17

Remark: 1. Correction Factor = Antenna factor + Insertion loss (cable loss + amplifier gain)

2. Margin = Limit –MAX Peak/ Average

802.11n (HT20) CH120

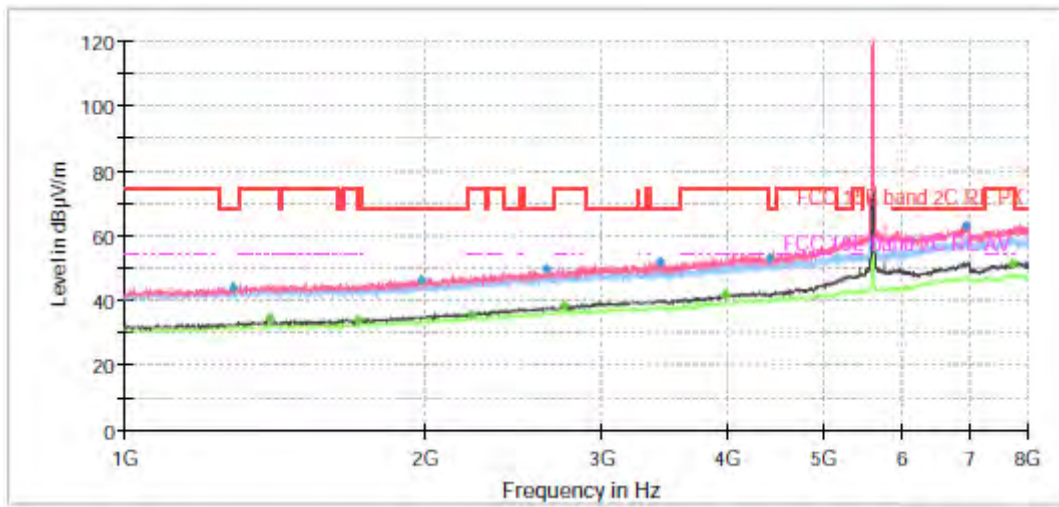

Note: The signal beyond the limit is carrier.
Radiates Emission from 1GHz to 8GHz

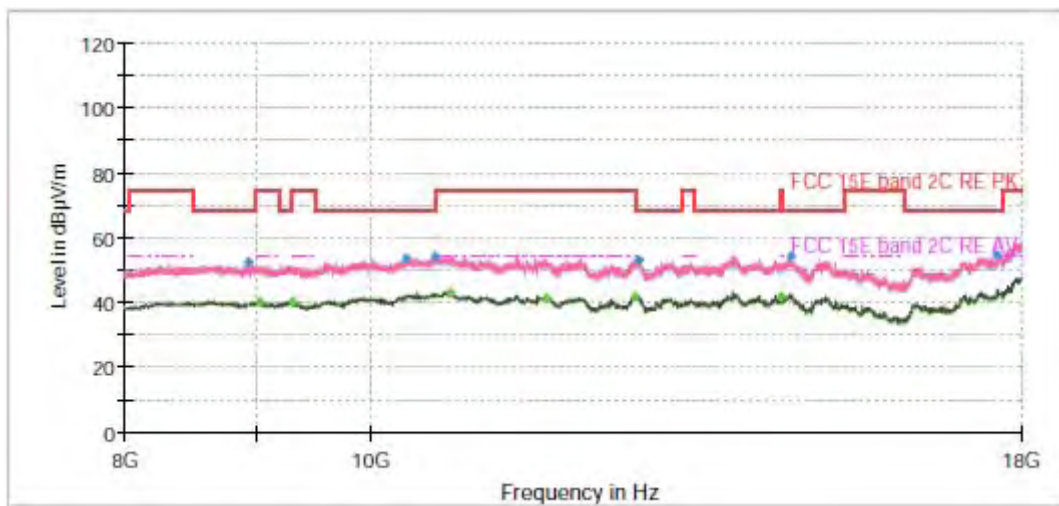

Radiates Emission from 8GHz to 18GHz

Frequency (MHz)	MaxPeak (dB μ V/m)	Average (dB μ V/m)	Limit (dB μ V/m)	Margin (dB)	Meas. Time (ms)	Height (cm)	Pol	Azimuth (deg)	Corr. (dB/m)
1280.00	43.89	---	68.20	24.31	500.00	100.0	V	116.00	-2
1396.38	---	34.47	54.00	19.53	500.00	100.0	V	352.00	-1
1709.63	---	33.95	54.00	20.05	500.00	200.0	V	157.00	0
1979.13	46.52	---	68.20	21.68	500.00	100.0	V	256.00	1
2224.13	---	35.61	54.00	18.39	500.00	200.0	V	6.00	2
2640.63	49.58	---	68.20	18.62	500.00	100.0	V	330.00	4
2746.50	---	38.40	54.00	15.60	500.00	100.0	V	270.00	4
3423.75	51.72	---	68.20	16.48	500.00	100.0	V	170.00	5
3993.38	---	41.90	54.00	12.10	500.00	200.0	V	2.00	6
4411.63	53.27	---	68.20	14.93	500.00	100.0	V	330.00	6
6951.75	63.30	---	68.20	4.90	500.00	200.0	V	1.00	14
7719.13	---	51.09	54.00	2.91	500.00	200.0	V	9.00	17

Remark: 1. Correction Factor = Antenna factor + Insertion loss (cable loss + amplifier gain)

2. Margin = Limit –MAX Peak/ Average

802.11n (HT20) CH140

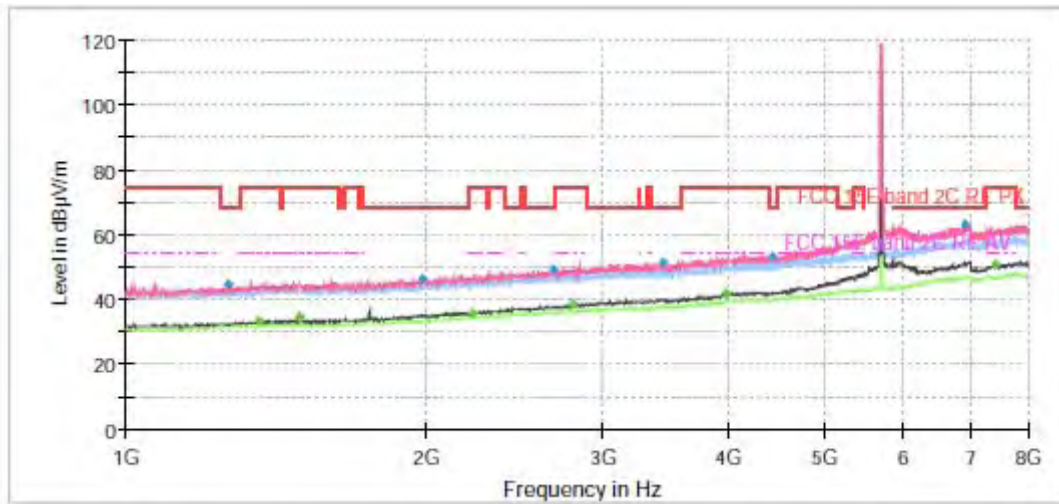

Note: The signal beyond the limit is carrier.
Radiates Emission from 1GHz to 8GHz

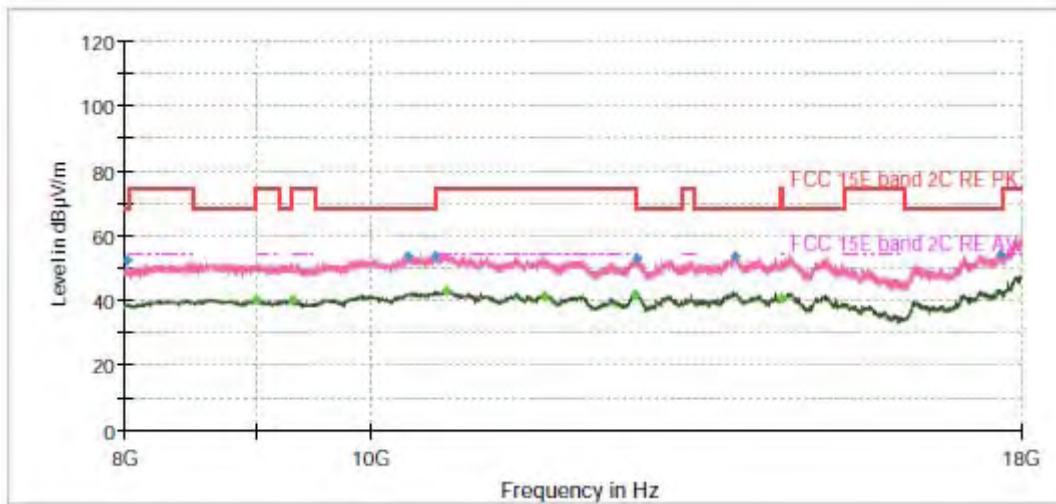

Radiates Emission from 8GHz to 18GHz

Frequency (MHz)	MaxPeak (dB μ V/m)	Average (dB μ V/m)	Limit (dB μ V/m)	Margin (dB)	Meas. Time (ms)	Height (cm)	Pol	Azimuth (deg)	Corr. (dB/m)
1264.25	44.62	---	68.20	23.58	500.00	100.0	V	149.00	-2
1357.88	---	33.48	54.00	20.52	500.00	100.0	V	33.00	-1
1493.50	---	34.37	54.00	19.63	500.00	100.0	V	0.00	-1
1978.25	46.42	---	68.20	21.78	500.00	100.0	V	156.00	1
2224.13	---	35.67	54.00	18.33	500.00	200.0	V	56.00	2
2673.00	49.33	---	68.20	18.87	500.00	200.0	V	2.00	4
2799.00	---	38.34	54.00	15.66	500.00	200.0	V	8.00	4
3448.25	51.38	---	68.20	16.82	500.00	200.0	V	90.00	5
3996.00	---	41.66	54.00	12.34	500.00	200.0	V	8.00	6
4433.50	53.23	---	68.20	14.97	500.00	200.0	V	0.00	7
6920.25	63.30	---	68.20	4.90	500.00	100.0	V	191.00	13
7420.75	---	50.99	54.00	3.01	500.00	200.0	V	2.00	16

Remark: 1. Correction Factor = Antenna factor + Insertion loss (cable loss + amplifier gain)

2. Margin = Limit –MAX Peak/ Average

802.11n (HT20) CH144

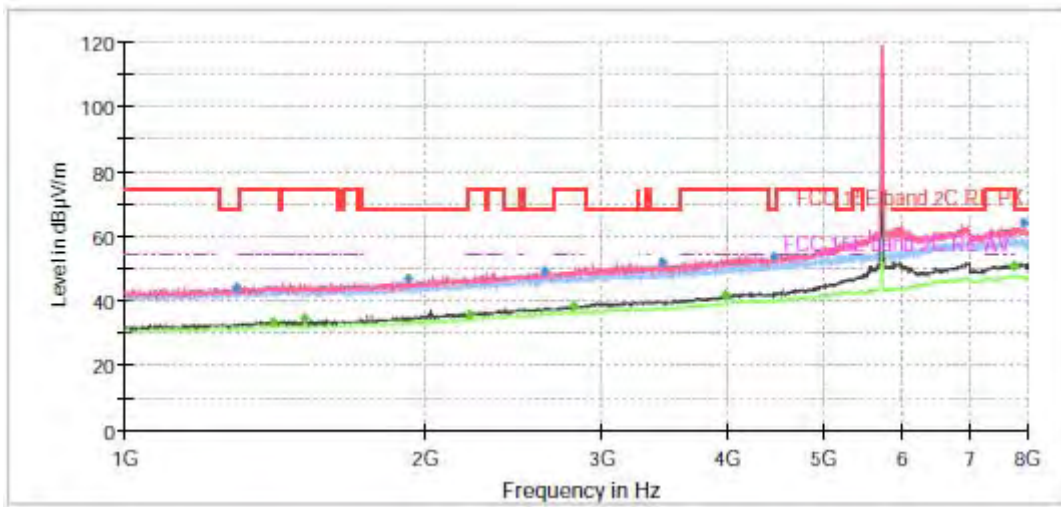

Note: The signal beyond the limit is carrier.
Radiates Emission from 1GHz to 8GHz

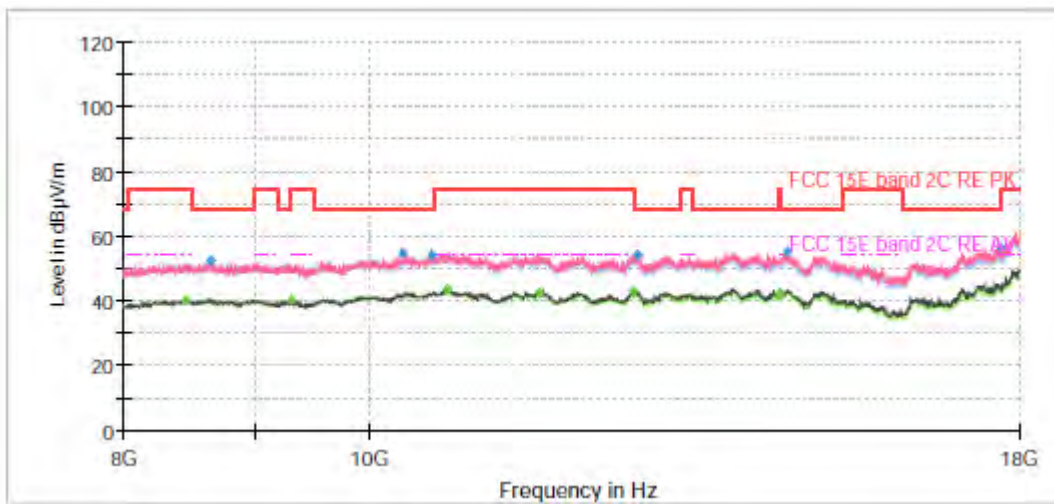

Radiates Emission from 8GHz to 18GHz

Frequency (MHz)	MaxPeak (dB μ V/m)	Average (dB μ V/m)	Limit (dB μ V/m)	Margin (dB)	Meas. Time (ms)	Height (cm)	Pol	Azimuth (deg)	Corr. (dB/m)
1294.88	44.19	---	68.20	24.01	500.00	100.0	V	0.00	-1
1405.13	---	33.59	54.00	20.41	500.00	100.0	V	166.00	-1
1513.63	---	34.77	54.00	19.23	500.00	200.0	V	197.00	-1
1917.88	46.71	---	68.20	21.49	500.00	200.0	V	0.00	0
2211.00	---	35.61	54.00	18.39	500.00	200.0	V	264.00	2
2624.00	49.22	---	68.20	18.98	500.00	100.0	V	358.00	4
2808.63	---	38.35	54.00	15.65	500.00	200.0	V	21.00	4
3438.63	51.77	---	68.20	16.43	500.00	200.0	V	89.00	5
3992.50	---	41.87	54.00	12.13	500.00	200.0	V	164.00	6
4455.38	53.62	---	68.20	14.58	500.00	200.0	V	5.00	7
7742.75	---	51.07	54.00	2.93	500.00	200.0	V	2.00	17
7922.13	64.09	---	68.20	4.11	500.00	100.0	V	335.00	17

Remark: 1. Correction Factor = Antenna factor + Insertion loss (cable loss + amplifier gain)

2. Margin = Limit –MAX Peak/ Average

802.11n (HT20) CH149

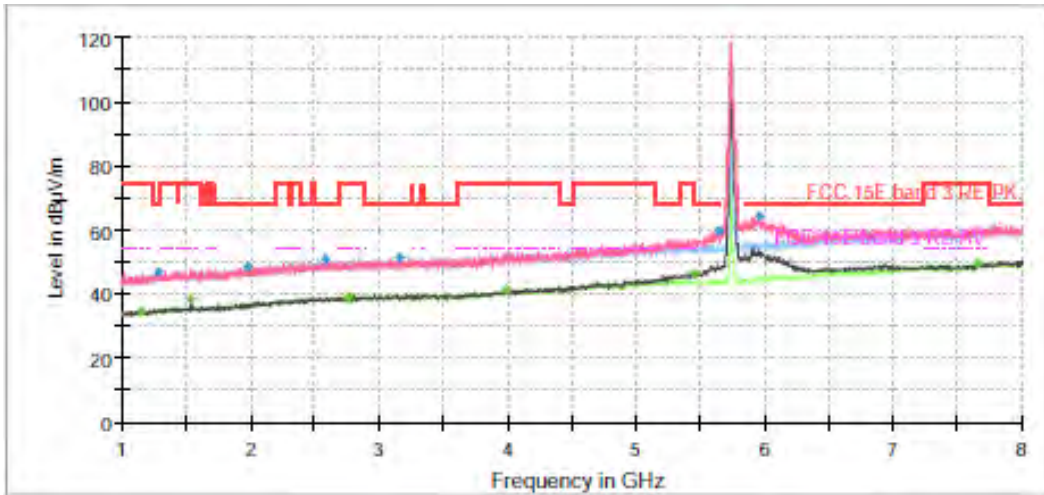

Note: The signal beyond the limit is carrier.
Radiates Emission from 1GHz to 8GHz

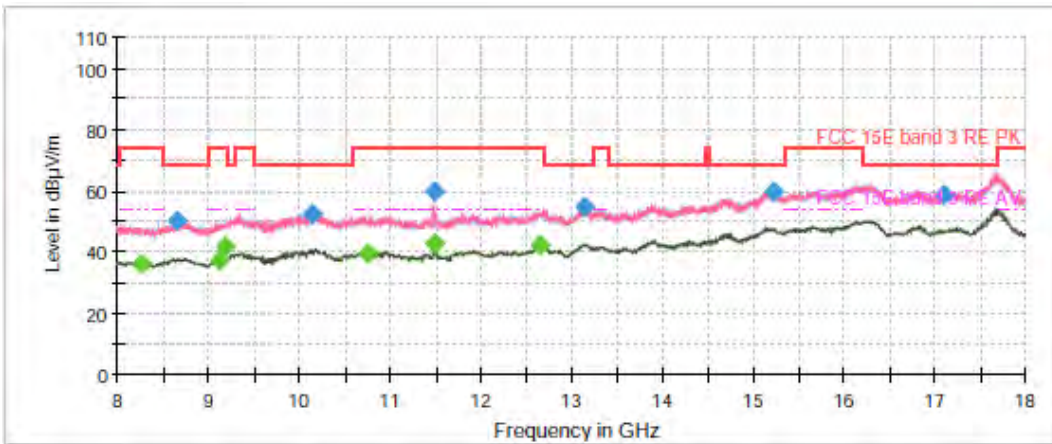

Radiates Emission from 8GHz to 18GHz

Frequency (MHz)	MaxPeak (dB μ V/m)	Average (dB μ V/m)	Limit (dB μ V/m)	Margin (dB)	Meas. Time (ms)	Height (cm)	Pol	Azimuth (deg)	Corr. (dB/m)
1141.75	---	34.69	54.00	19.31	500.00	200.0	V	25.00	-10
1282.63	46.86	---	68.20	21.34	500.00	100.0	V	233.00	-10
1539.88	---	38.36	54.00	15.64	500.00	200.0	V	2.00	-9
1978.25	48.47	---	68.20	19.73	500.00	100.0	V	258.00	-8
2576.75	50.56	---	68.20	17.64	500.00	200.0	V	2.00	-6
2762.25	---	39.11	54.00	14.89	500.00	100.0	V	0.00	-5
3165.63	51.59	---	68.20	16.61	500.00	100.0	V	241.00	-5
3983.75	---	41.03	54.00	12.97	500.00	100.0	V	0.00	-2
5459.88	---	46.25	54.00	7.75	500.00	200.0	V	10.00	3
5645.38	59.55	---	68.20	8.65	500.00	200.0	V	1.00	3
5952.50	64.03	---	68.20	4.17	500.00	200.0	V	3.00	4
7654.38	---	49.49	54.00	4.51	500.00	100.0	V	71.00	9

Remark: 1. Correction Factor = Antenna factor + Insertion loss (cable loss + amplifier gain)

2. Margin = Limit –MAX Peak/ Average

802.11n (HT20) CH157

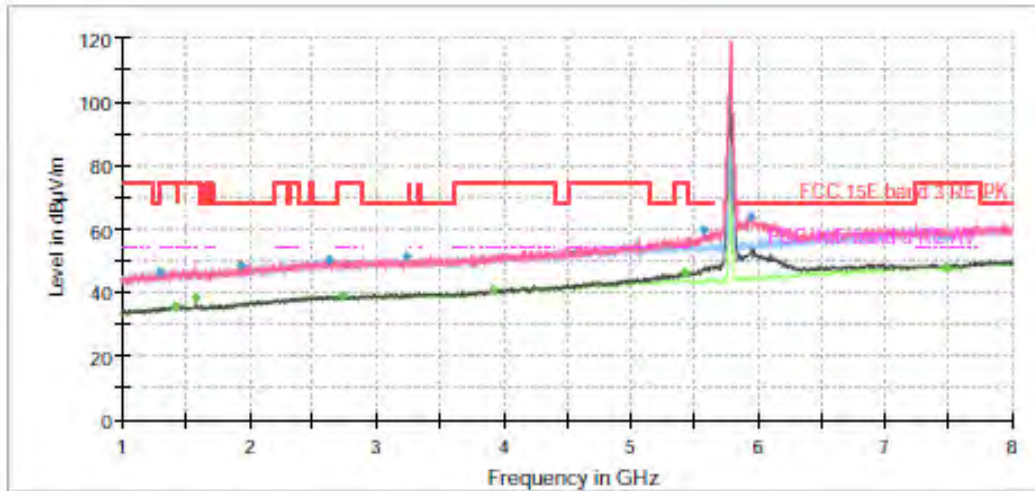

Note: The signal beyond the limit is carrier.
Radiates Emission from 1GHz to 8GHz

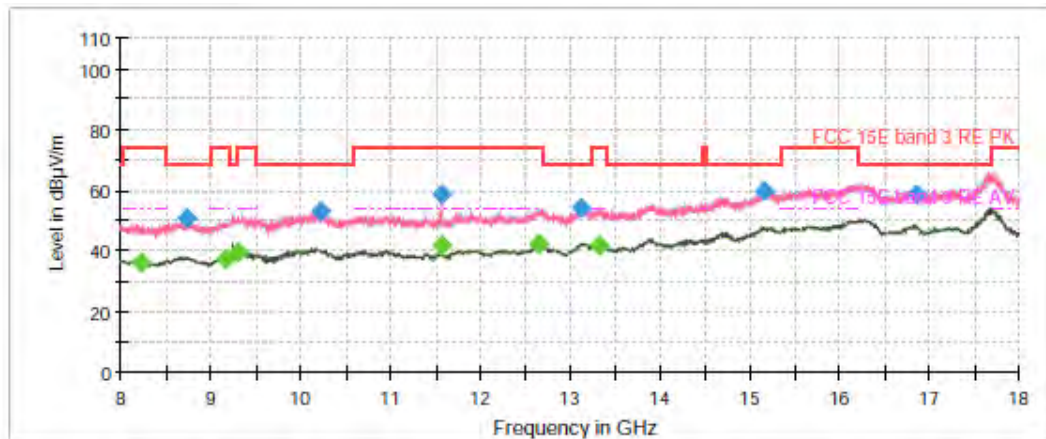

Radiates Emission from 8GHz to 18GHz

Frequency (MHz)	MaxPeak (dB μ V/m)	Average (dB μ V/m)	Limit (dB μ V/m)	Margin (dB)	Meas. Time (ms)	Height (cm)	Pol	Azimuth (deg)	Corr. (dB/m)
1288.75	46.28	---	68.20	21.92	500.00	200.0	V	20.00	-9
1407.75	---	35.87	54.00	18.13	500.00	200.0	V	0.00	-9
1579.25	---	38.59	54.00	15.41	500.00	200.0	V	3.00	-9
1938.88	48.41	---	68.20	19.79	500.00	100.0	V	336.00	-8
2624.00	50.49	---	68.20	17.71	500.00	100.0	V	359.00	-6
2735.13	---	38.97	54.00	15.03	500.00	200.0	V	33.00	-5
3237.38	51.46	---	68.20	16.74	500.00	200.0	V	162.00	-4
3911.13	---	40.85	54.00	13.15	500.00	100.0	V	336.00	-2
5425.75	---	46.11	54.00	7.89	500.00	200.0	V	0.00	3
5571.88	59.53	---	68.20	8.67	500.00	200.0	V	11.00	3
5935.88	63.63	---	68.20	4.57	500.00	200.0	V	153.00	4
7485.50	---	48.24	54.00	5.76	500.00	100.0	V	356.00	8

Remark: 1. Correction Factor = Antenna factor + Insertion loss (cable loss + amplifier gain)

2. Margin = Limit –MAX Peak/ Average

802.11n (HT20) CH165

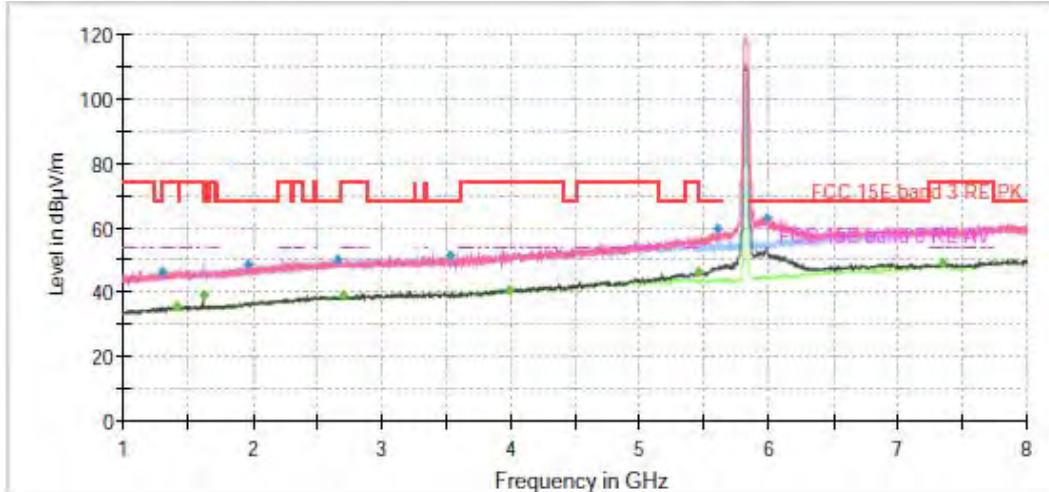

Note: The signal beyond the limit is carrier.
Radiates Emission from 1GHz to 8GHz

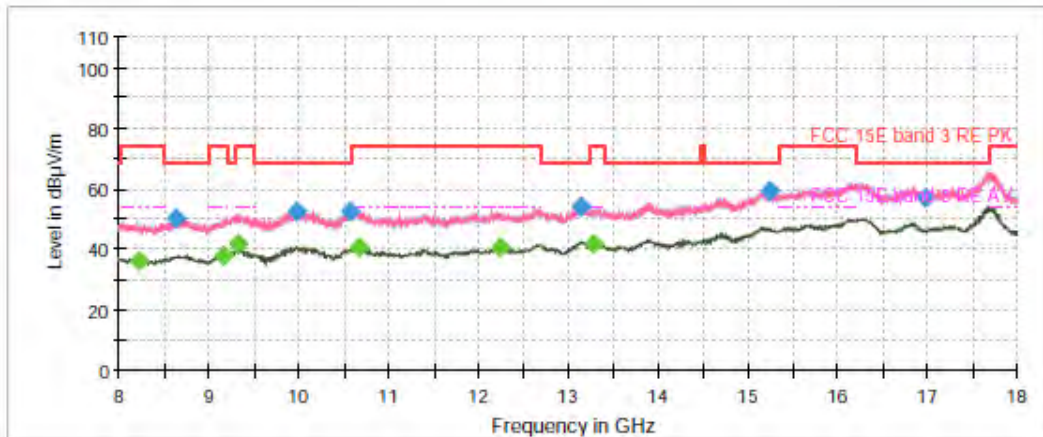

Radiates Emission from 8GHz to 18GHz

Frequency (MHz)	MaxPeak (dB μ V/m)	Average (dB μ V/m)	Limit (dB μ V/m)	Margin (dB)	Meas. Time (ms)	Height (cm)	Pol	Azimuth (deg)	Corr. (dB/m)
1288.75	46.46	---	68.20	21.74	500.00	200.0	V	249.00	-9
1411.25	---	35.78	54.00	18.22	500.00	100.0	V	351.00	-9
1618.63	---	39.22	54.00	14.78	500.00	200.0	V	346.00	-9
1960.75	48.51	---	68.20	19.69	500.00	200.0	V	8.00	-8
2662.50	50.02	---	68.20	18.18	500.00	200.0	H	196.00	-6
2696.63	---	39.20	54.00	14.80	500.00	200.0	V	27.00	-5
3537.50	51.60	---	68.20	16.60	500.00	100.0	H	96.00	-4
3993.38	---	40.94	54.00	13.06	500.00	200.0	V	11.00	-2
5454.63	---	46.16	54.00	7.84	500.00	200.0	V	11.00	3
5601.63	59.45	---	68.20	8.75	500.00	200.0	V	21.00	3
5989.25	63.27	---	68.20	4.93	500.00	200.0	V	0.00	4
7349.00	---	48.91	54.00	5.09	500.00	200.0	V	2.00	8

Remark: 1. Correction Factor = Antenna factor + Insertion loss (cable loss + amplifier gain)

2. Margin = Limit - MAX Peak/ Average

802.11n (HT40) CH38

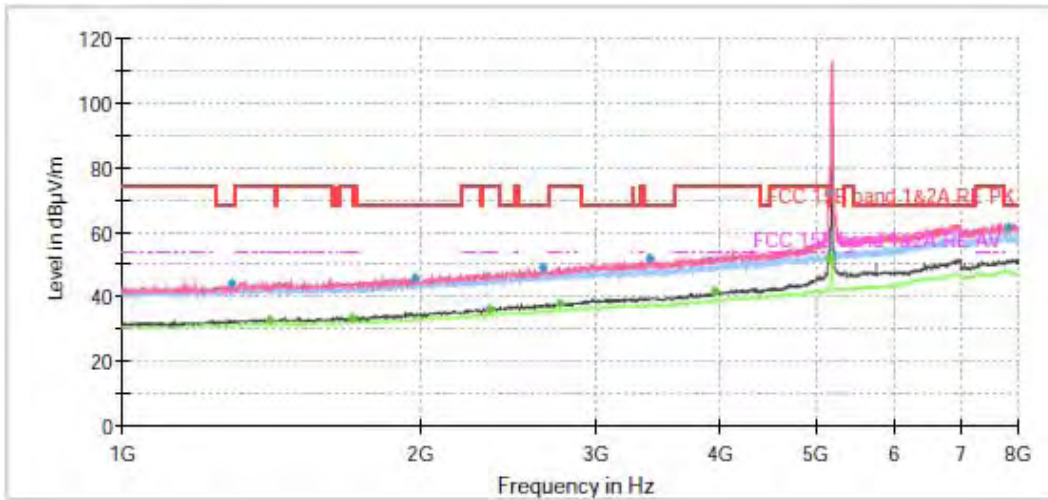

Note: The signal beyond the limit is carrier.
Radiates Emission from 1GHz to 8GHz

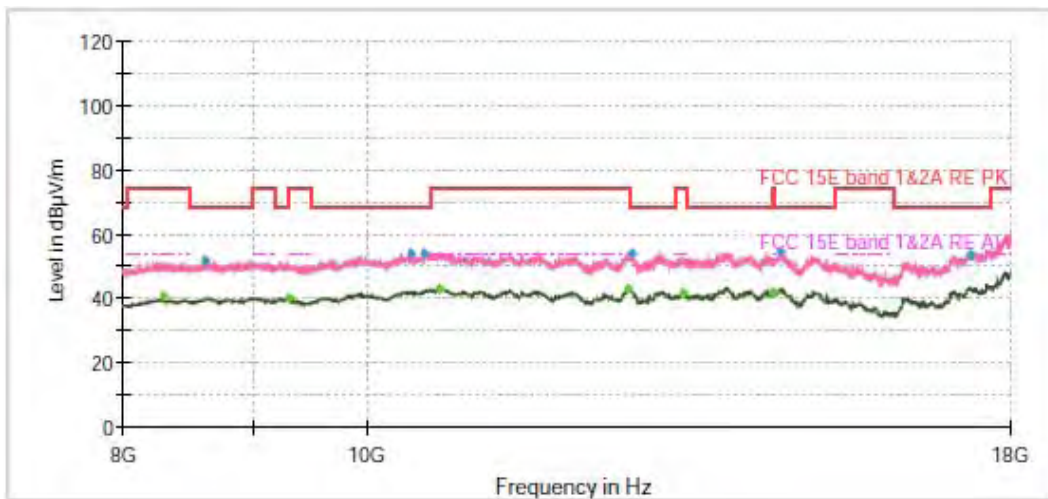

Radiates Emission from 8GHz to 18GHz

Frequency (MHz)	MaxPeak (dB μ V/m)	Average (dB μ V/m)	Limit (dB μ V/m)	Margin (dB)	Meas. Time (ms)	Height (cm)	Pol	Azimuth (deg)	Corr. (dB/m)
1286.13	44.11	---	68.20	24.09	500.00	100.0	V	134.00	-2
1404.25	---	33.19	54.00	20.81	500.00	200.0	V	312.00	-1
1706.13	---	33.60	54.00	20.40	500.00	100.0	V	0.00	-1
1971.25	45.85	---	68.20	22.35	500.00	100.0	V	154.00	1
2344.00	---	36.15	54.00	17.85	500.00	100.0	V	1.00	2
2648.50	49.13	---	68.20	19.07	500.00	200.0	V	0.00	4
2762.25	---	38.20	54.00	15.80	500.00	200.0	V	76.00	4
3397.50	51.64	---	68.20	16.56	500.00	100.0	V	33.00	5
3960.13	---	41.72	54.00	12.28	500.00	200.0	V	351.00	6
5149.25	71.86	---	74.00	2.14	500.00	200.0	V	187.00	10
5149.25	---	52.00	54.00	2.00	500.00	100.0	V	33.00	10
7839.88	61.20	---	68.20	7.00	500.00	200.0	V	97.00	17

Remark: 1. Correction Factor = Antenna factor + Insertion loss (cable loss + amplifier gain)

2. Margin = Limit –MAX Peak/ Average

802.11n (HT40) CH46

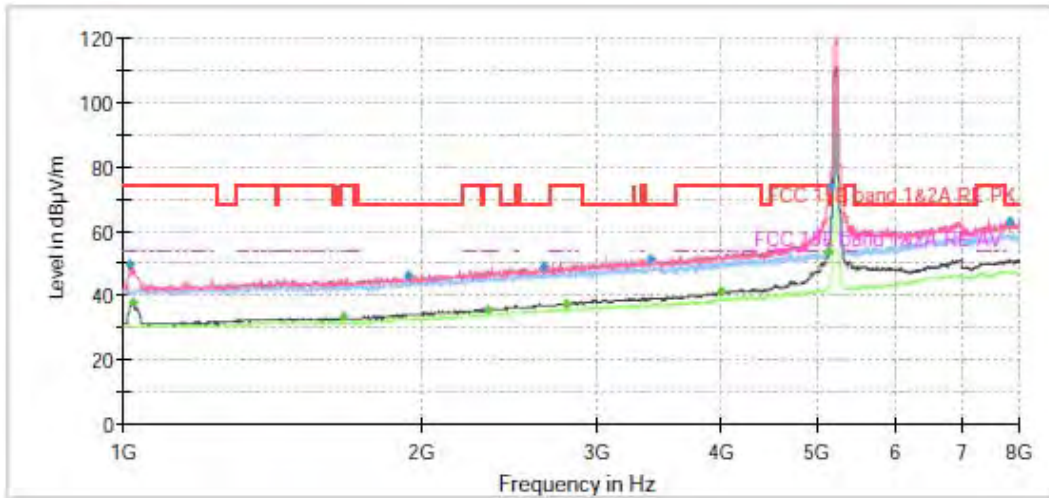

Note: The signal beyond the limit is carrier.
Radiates Emission from 1GHz to 8GHz

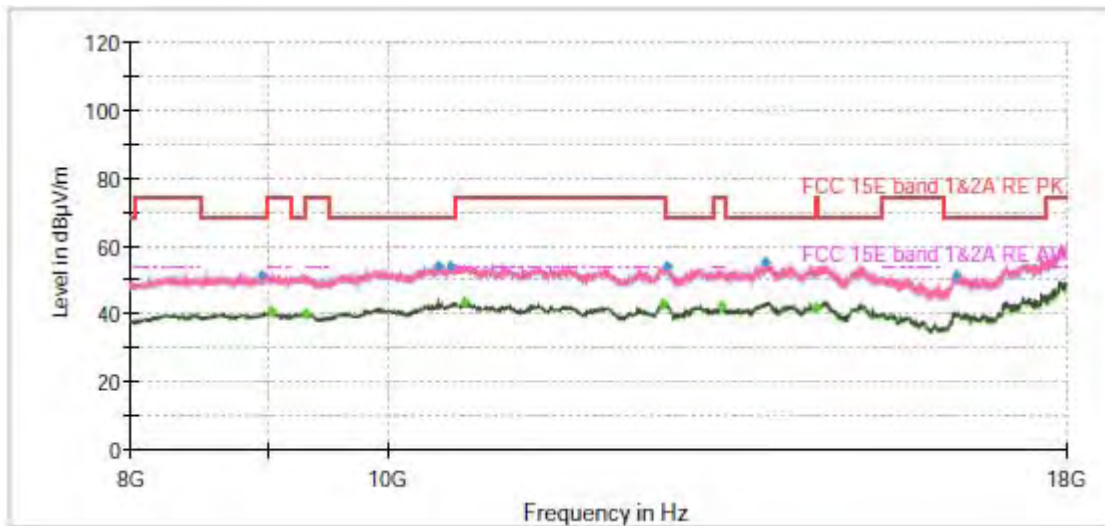

Radiates Emission from 8GHz to 18GHz

Frequency (MHz)	MaxPeak (dB μ V/m)	Average (dB μ V/m)	Limit (dB μ V/m)	Margin (dB)	Meas. Time (ms)	Height (cm)	Pol	Azimuth (deg)	Corr. (dB/m)
1014.00	49.59	---	74.00	24.41	500.00	100.0	V	27.00	-3
1022.75	---	38.07	54.00	15.93	500.00	200.0	V	170.00	-3
1663.25	---	33.22	54.00	20.78	500.00	100.0	V	198.00	-1
1939.75	46.29	---	68.20	21.91	500.00	200.0	V	232.00	1
2337.00	---	35.48	54.00	18.52	500.00	200.0	V	353.00	2
2655.50	49.02	---	68.20	19.18	500.00	100.0	V	121.00	4
2799.00	---	37.47	54.00	16.53	500.00	200.0	V	294.00	4
3404.50	51.62	---	68.20	16.58	500.00	200.0	V	115.00	5
3999.50	---	41.08	54.00	12.92	500.00	100.0	V	97.00	6
5130.00	---	53.32	54.00	0.68	500.00	200.0	V	159.00	10
5149.25	73.63	---	74.00	0.37	500.00	200.0	V	159.00	10
7830.25	63.07	---	68.20	5.13	500.00	200.0	V	353.00	17

Remark: 1. Correction Factor = Antenna factor + Insertion loss (cable loss + amplifier gain)

2. Margin = Limit - MAX Peak/ Average

802.11n (HT40) CH54

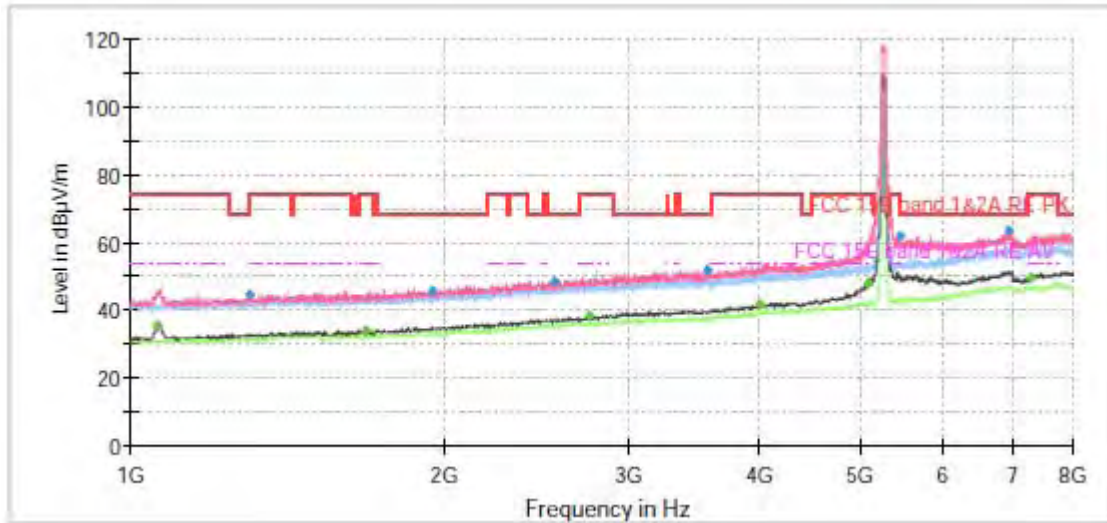

Note: The signal beyond the limit is carrier.
Radiates Emission from 1GHz to 8GHz

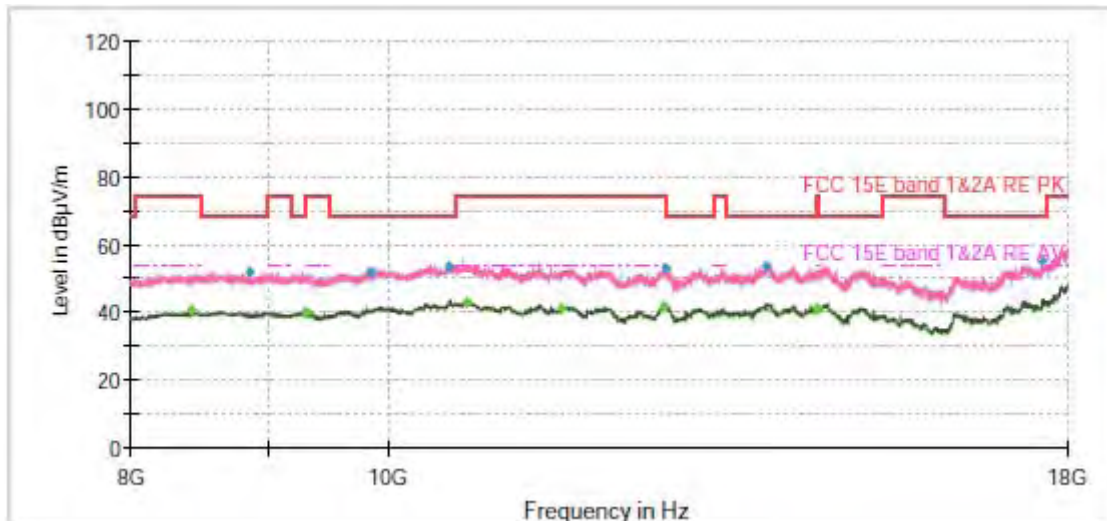

Radiates Emission from 8GHz to 18GHz

Frequency (MHz)	MaxPeak (dB μ V/m)	Average (dB μ V/m)	Limit (dB μ V/m)	Margin (dB)	Meas. Time (ms)	Height (cm)	Pol	Azimuth (deg)	Corr. (dB/m)
1060.38	---	35.60	54.00	18.40	500.00	200.0	V	121.00	-3
1298.38	44.43	---	68.20	23.77	500.00	200.0	V	81.00	-1
1676.38	---	33.92	54.00	20.08	500.00	200.0	V	141.00	-1
1947.63	46.02	---	68.20	22.18	500.00	200.0	V	264.00	1
2554.00	48.83	---	68.20	19.37	500.00	100.0	V	212.00	3
2746.50	---	38.42	54.00	15.58	500.00	200.0	V	188.00	4
3569.00	51.65	---	68.20	16.55	500.00	200.0	V	196.00	5
3999.50	---	42.06	54.00	11.94	500.00	200.0	V	0.00	6
5092.38	---	48.21	54.00	5.79	500.00	100.0	V	352.00	10
5468.13	61.77	---	68.20	6.23	500.00	200.0	V	175.00	11
6932.50	63.36	---	68.20	4.84	500.00	200.0	V	175.00	14
7286.88	---	49.59	54.00	4.41	500.00	200.0	V	4.00	15

Remark: 1. Correction Factor = Antenna factor + Insertion loss (cable loss + amplifier gain)

2. Margin = Limit - MAX Peak/ Average

802.11n (HT40) CH62

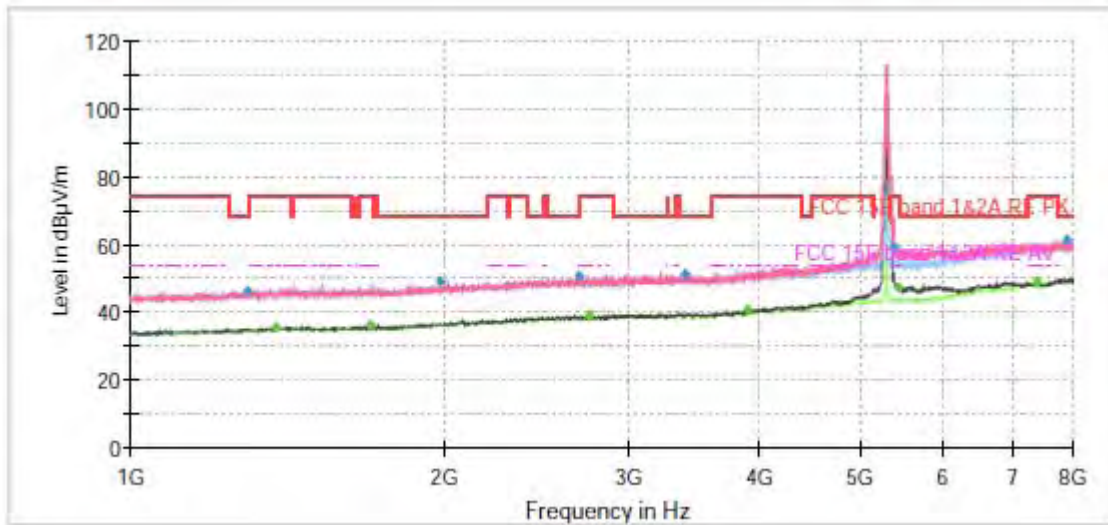

Note: The signal beyond the limit is carrier.
Radiates Emission from 1GHz to 8GHz

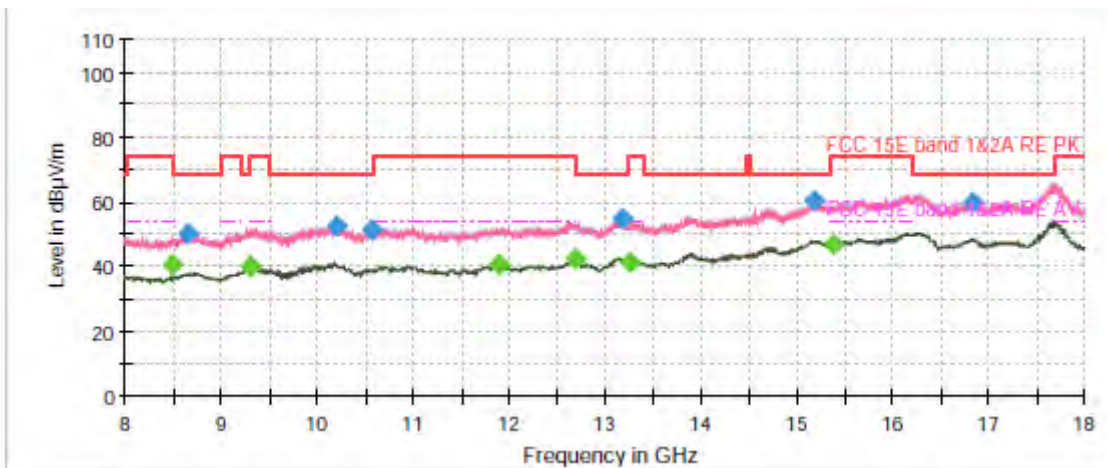

Radiates Emission from 8GHz to 18GHz

Frequency (MHz)	MaxPeak (dB μ V/m)	Average (dB μ V/m)	Limit (dB μ V/m)	Margin (dB)	Meas. Time (ms)	Height (cm)	Pol	Azimuth (deg)	Corr. (dB/m)
1294.00	46.51	---	68.20	21.69	500.00	100.0	H	5.00	-9
1378.00	---	35.63	54.00	18.37	500.00	200.0	V	0.00	-9
1694.75	---	36.06	54.00	17.94	500.00	100.0	H	328.00	-8
1980.88	49.05	---	68.20	19.15	500.00	200.0	V	48.00	-8
2683.50	50.63	---	68.20	17.57	500.00	200.0	V	48.00	-6
2744.75	---	39.01	54.00	14.99	500.00	100.0	V	243.00	-5
3407.13	51.29	---	68.20	16.91	500.00	100.0	V	355.00	-4
3902.38	---	40.99	54.00	13.01	500.00	100.0	V	203.00	-2
5396.88	59.23	---	74.00	14.77	500.00	200.0	V	191.00	3
5437.13	---	47.34	54.00	6.67	500.00	200.0	V	333.00	3
7396.25	---	49.13	54.00	4.87	500.00	100.0	V	70.00	8
7887.13	61.44	---	68.20	6.76	500.00	100.0	V	14.00	9

Remark: 1. Correction Factor = Antenna factor + Insertion loss (cable loss + amplifier gain)

2. Margin = Limit - MAX Peak/ Average

802.11n (HT40) CH102

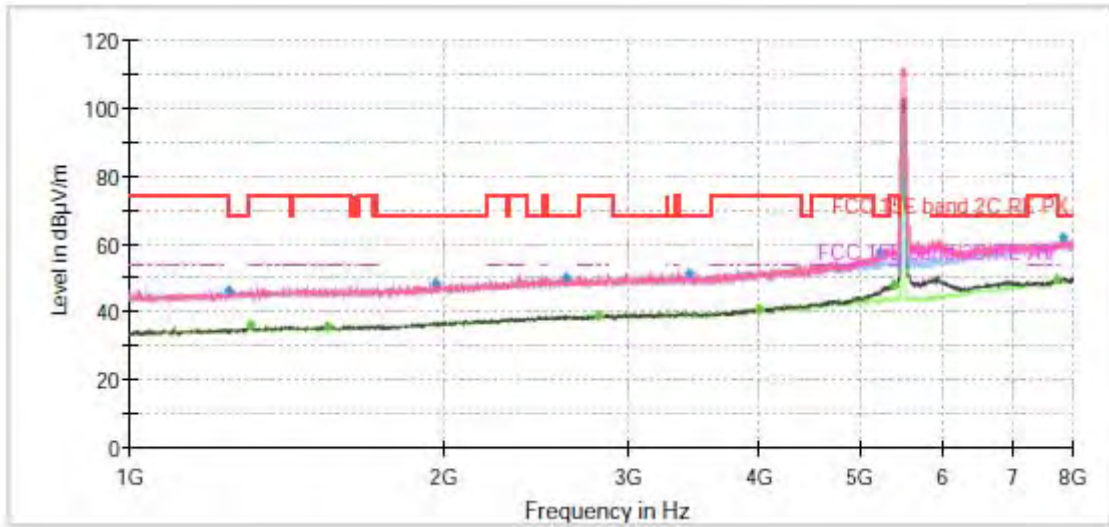

Note: The signal beyond the limit is carrier.
Radiates Emission from 1GHz to 8GHz

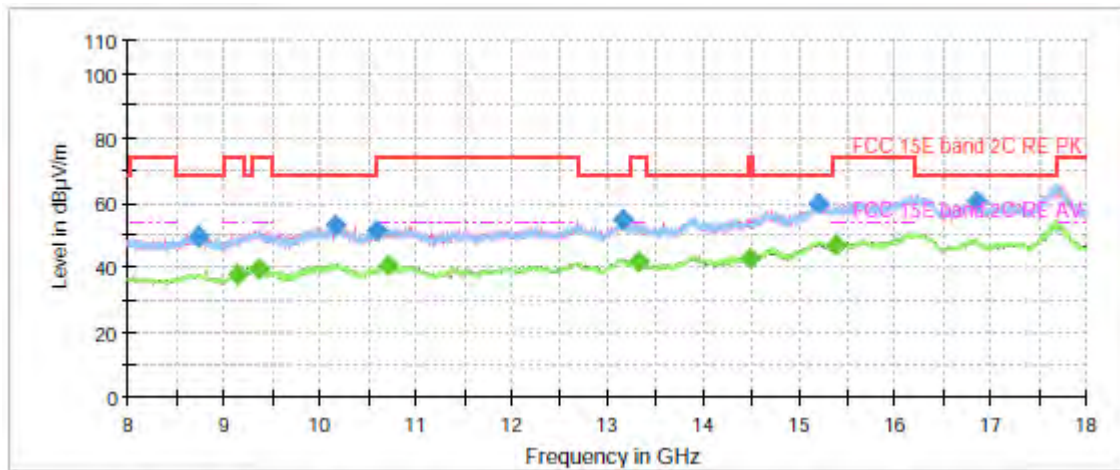

Radiates Emission from 8GHz to 18GHz

Frequency (MHz)	MaxPeak (dB μ V/m)	Average (dB μ V/m)	Limit (dB μ V/m)	Margin (dB)	Meas. Time (ms)	Height (cm)	Pol	Azimuth (deg)	Corr. (dB/m)
1240.63	46.51	---	68.20	21.69	500.00	100.0	H	50.00	-10
1303.63	---	36.18	54.00	17.82	500.00	200.0	V	4.00	-9
1541.63	---	35.94	54.00	18.06	500.00	200.0	H	321.00	-9
1958.13	48.55	---	68.20	19.65	500.00	100.0	V	356.00	-8
2619.63	50.29	---	68.20	17.91	500.00	100.0	V	106.00	-6
2805.13	---	39.09	54.00	14.91	500.00	200.0	H	211.00	-5
3432.50	51.55	---	68.20	16.65	500.00	100.0	V	112.00	-4
3999.50	---	41.00	54.00	13.00	500.00	200.0	V	144.00	-2
5217.50	57.26	---	68.20	10.94	500.00	100.0	V	166.00	2
5398.63	---	47.87	54.00	6.13	500.00	200.0	V	333.00	3
7731.38	---	49.69	54.00	4.31	500.00	100.0	H	270.00	9
7824.13	61.94	---	68.20	6.26	500.00	200.0	V	36.00	9

Remark: 1. Correction Factor = Antenna factor + Insertion loss (cable loss + amplifier gain)

2. Margin = Limit - MAX Peak/ Average

802.11n (HT40) CH118

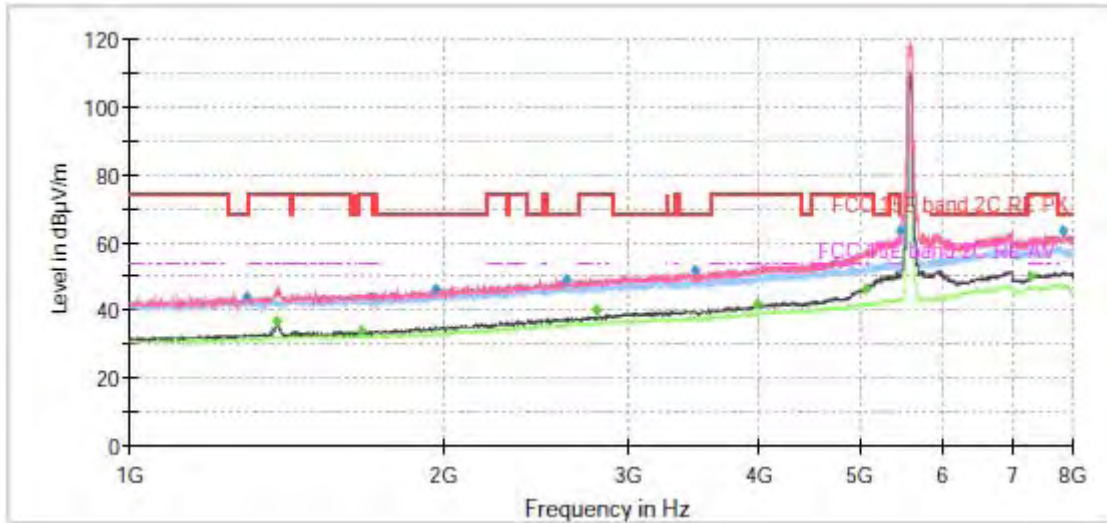

Note: The signal beyond the limit is carrier.
Radiates Emission from 1GHz to 8GHz

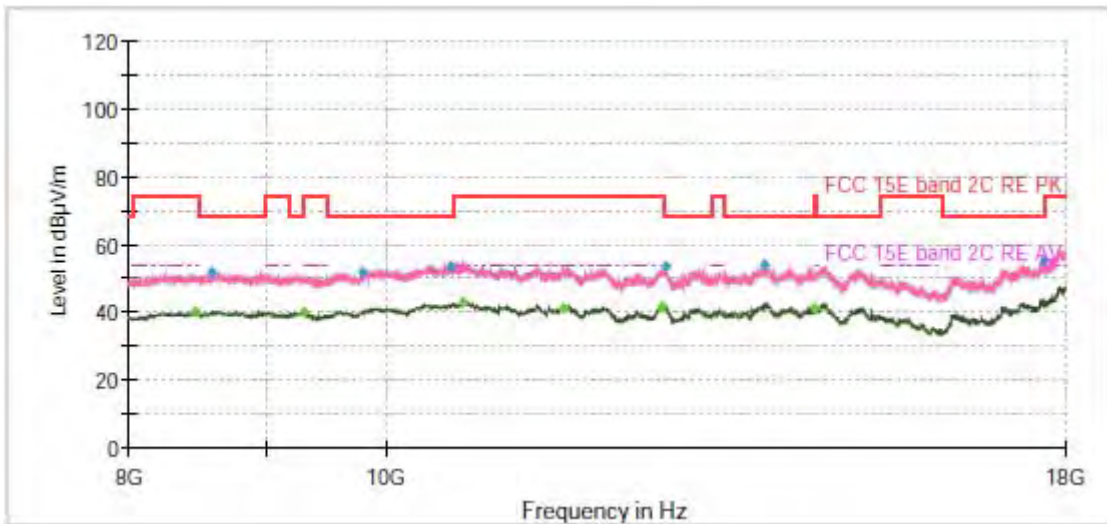

Radiates Emission from 8GHz to 18GHz

Frequency (MHz)	MaxPeak (dB μ V/m)	Average (dB μ V/m)	Limit (dB μ V/m)	Margin (dB)	Meas. Time (ms)	Height (cm)	Pol	Azimuth (deg)	Corr. (dB/m)
1294.00	44.36	---	68.20	23.84	500.00	200.0	V	0.00	-1
1385.00	---	36.73	54.00	17.27	500.00	200.0	V	176.00	-1
1665.00	---	34.12	54.00	19.88	500.00	200.0	V	142.00	-1
1964.25	46.15	---	68.20	22.05	500.00	100.0	V	0.00	1
2618.75	49.30	---	68.20	18.90	500.00	200.0	V	156.00	4
2799.00	---	39.95	54.00	14.05	500.00	100.0	H	111.00	4
3480.63	52.03	---	68.20	16.17	500.00	100.0	V	285.00	5
3993.38	---	41.60	54.00	12.40	500.00	200.0	V	284.00	6
5056.50	---	46.48	54.00	7.52	500.00	100.0	V	48.00	9
5464.25	63.83	---	68.20	4.37	500.00	200.0	V	4.00	11
7280.75	---	49.96	54.00	4.04	500.00	200.0	V	22.00	15
7810.13	63.42	---	68.20	4.78	500.00	200.0	V	0.00	17

Remark: 1. Correction Factor = Antenna factor + Insertion loss (cable loss + amplifier gain)

2. Margin = Limit –MAX Peak/ Average

802.11n (HT40) CH134

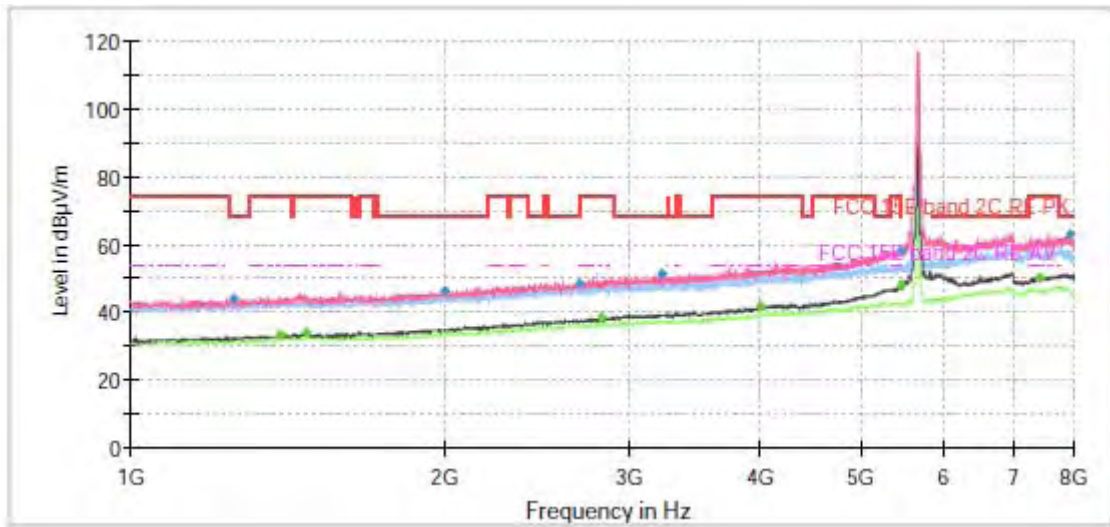

Note: The signal beyond the limit is carrier.
Radiates Emission from 1GHz to 8GHz

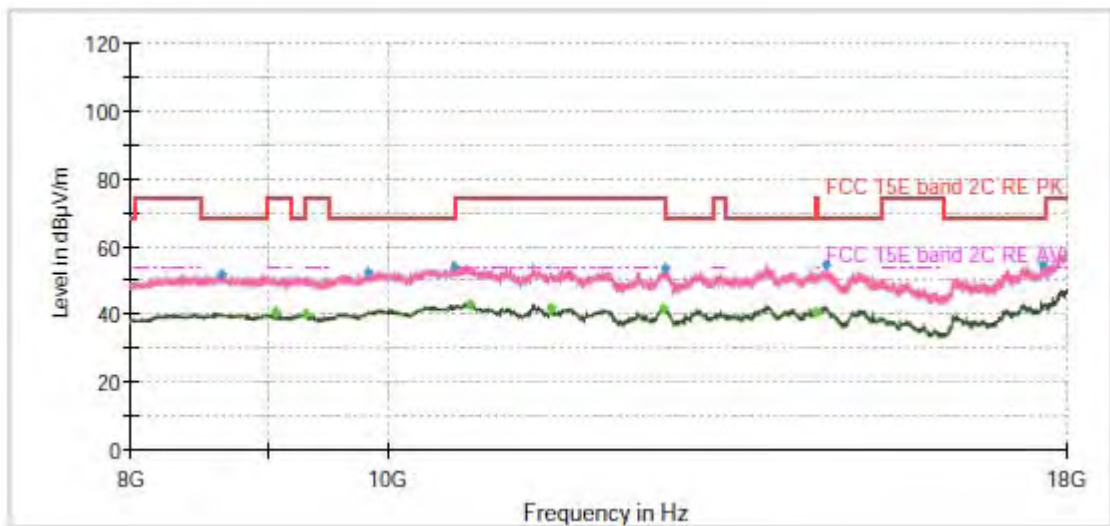

Radiates Emission from 8GHz to 18GHz

Frequency (MHz)	MaxPeak (dB μ V/m)	Average (dB μ V/m)	Limit (dB μ V/m)	Margin (dB)	Meas. Time (ms)	Height (cm)	Pol	Azimuth (deg)	Corr. (dB/m)
1253.75	44.12	---	68.20	24.08	500.00	200.0	V	216.00	-2
1386.75	---	33.51	54.00	20.49	500.00	200.0	V	115.00	-1
1468.13	---	34.03	54.00	19.97	500.00	200.0	V	60.00	-1
1994.88	46.33	---	68.20	21.87	500.00	200.0	V	128.00	1
2687.88	48.73	---	68.20	19.47	500.00	200.0	V	121.00	4
2824.38	---	38.30	54.00	15.70	500.00	200.0	V	230.00	4
3220.75	51.41	---	68.20	16.79	500.00	100.0	V	261.00	5
3999.50	---	41.65	54.00	12.35	500.00	100.0	V	241.00	6
5459.88	---	47.84	54.00	6.16	500.00	200.0	V	128.00	11
5468.63	58.05	---	68.20	10.15	500.00	200.0	V	141.00	11
7413.75	---	50.20	54.00	3.80	500.00	100.0	V	288.00	16
7926.50	63.27	---	68.20	4.93	500.00	100.0	V	348.00	17

Remark: 1. Correction Factor = Antenna factor + Insertion loss (cable loss + amplifier gain)

2. Margin = Limit –MAX Peak/ Average

802.11n (HT40) CH142

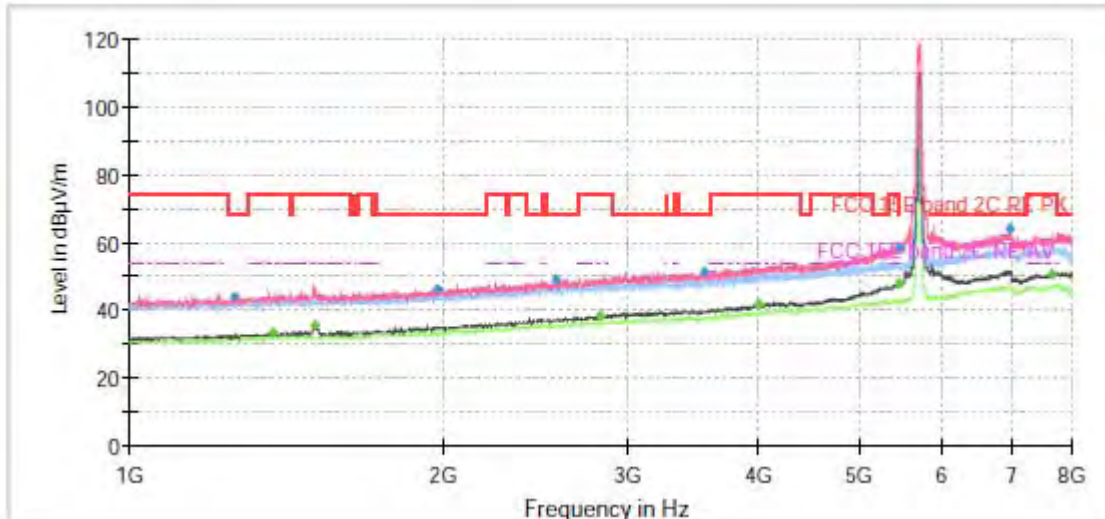

Note: The signal beyond the limit is carrier.
Radiates Emission from 1GHz to 8GHz

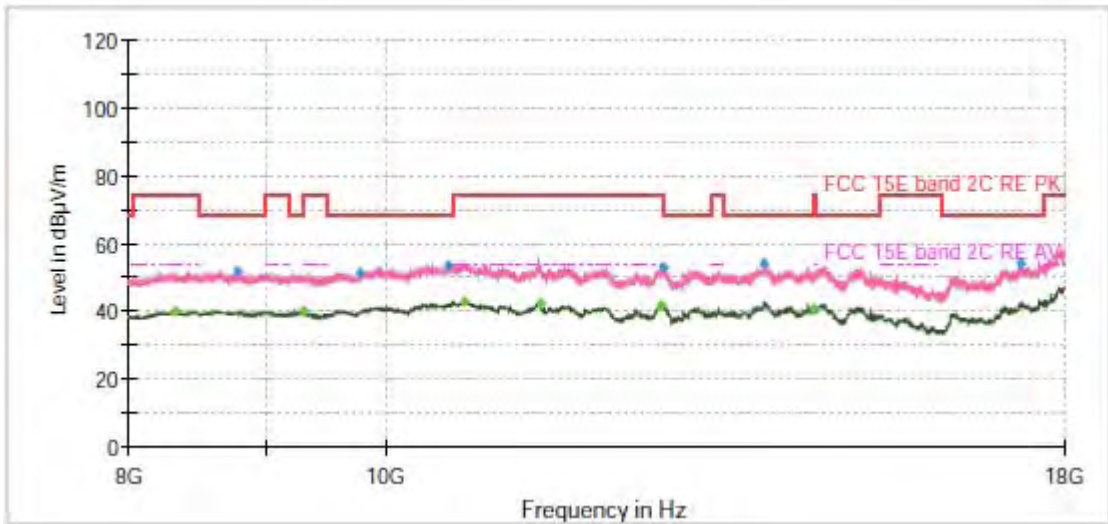

Radiates Emission from 8GHz to 18GHz

Frequency (MHz)	MaxPeak (dB μ V/m)	Average (dB μ V/m)	Limit (dB μ V/m)	Margin (dB)	Meas. Time (ms)	Height (cm)	Pol	Azimuth (deg)	Corr. (dB/m)
1257.25	43.94	---	68.20	24.26	500.00	200.0	V	168.00	-2
1371.88	---	33.54	54.00	20.46	500.00	200.0	V	180.00	-1
1504.00	---	35.88	54.00	18.12	500.00	200.0	V	120.00	-1
1966.88	46.10	---	68.20	22.10	500.00	200.0	V	12.00	1
2564.50	49.32	---	68.20	18.88	500.00	200.0	V	1.00	3
2821.75	---	38.30	54.00	15.70	500.00	200.0	V	160.00	4
3560.25	51.55	---	68.20	16.65	500.00	200.0	V	127.00	5
3999.50	---	41.70	54.00	12.30	500.00	100.0	V	190.00	6
5452.00	---	48.04	54.00	5.96	500.00	200.0	V	134.00	11
5466.00	58.55	---	68.20	9.65	500.00	200.0	V	160.00	11
6986.75	64.00	---	68.20	4.20	500.00	200.0	V	62.00	14
7666.63	---	50.93	54.00	3.07	500.00	200.0	V	6.00	17

Remark: 1. Correction Factor = Antenna factor + Insertion loss (cable loss + amplifier gain)

2. Margin = Limit –MAX Peak/ Average

802.11n (HT40) CH151

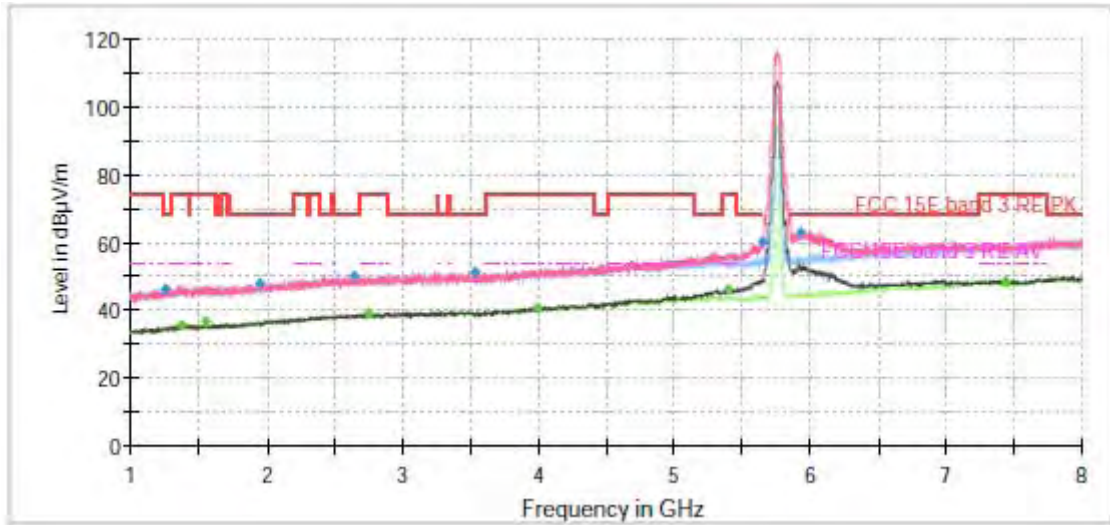

Note: The signal beyond the limit is carrier.
Radiates Emission from 1GHz to 8GHz

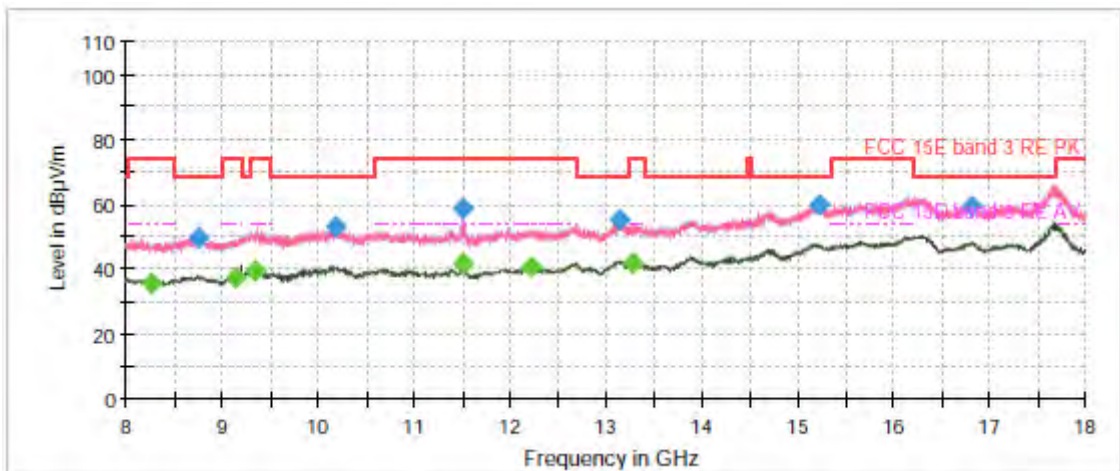

Radiates Emission from 8GHz to 18GHz

Frequency (MHz)	MaxPeak (dB μ V/m)	Average (dB μ V/m)	Limit (dB μ V/m)	Margin (dB)	Meas. Time (ms)	Height (cm)	Pol	Azimuth (deg)	Corr. (dB/m)
1246.75	46.52	---	68.20	21.68	500.00	200.0	V	0.00	-10
1376.25	---	35.60	54.00	18.40	500.00	100.0	H	138.00	-9
1549.50	---	36.71	54.00	17.29	500.00	200.0	V	256.00	-9
1951.13	48.28	---	68.20	19.92	500.00	200.0	V	101.00	-8
2649.38	50.42	---	68.20	17.78	500.00	200.0	V	273.00	-6
2751.75	---	38.94	54.00	15.06	500.00	200.0	H	12.00	-5
3534.00	51.52	---	68.20	16.68	500.00	100.0	V	177.00	-4
3982.88	---	40.85	54.00	13.15	500.00	100.0	V	318.00	-2
5398.63	---	46.54	54.00	7.46	500.00	200.0	V	1.00	3
5642.75	60.00	---	68.20	8.20	500.00	200.0	V	0.00	3
5931.50	63.16	---	68.20	5.04	500.00	200.0	V	24.00	4
7441.75	---	48.35	54.00	5.65	500.00	200.0	V	0.00	8

Remark: 1. Correction Factor = Antenna factor + Insertion loss (cable loss + amplifier gain)

2. Margin = Limit –MAX Peak/ Average

802.11n (HT40) CH159

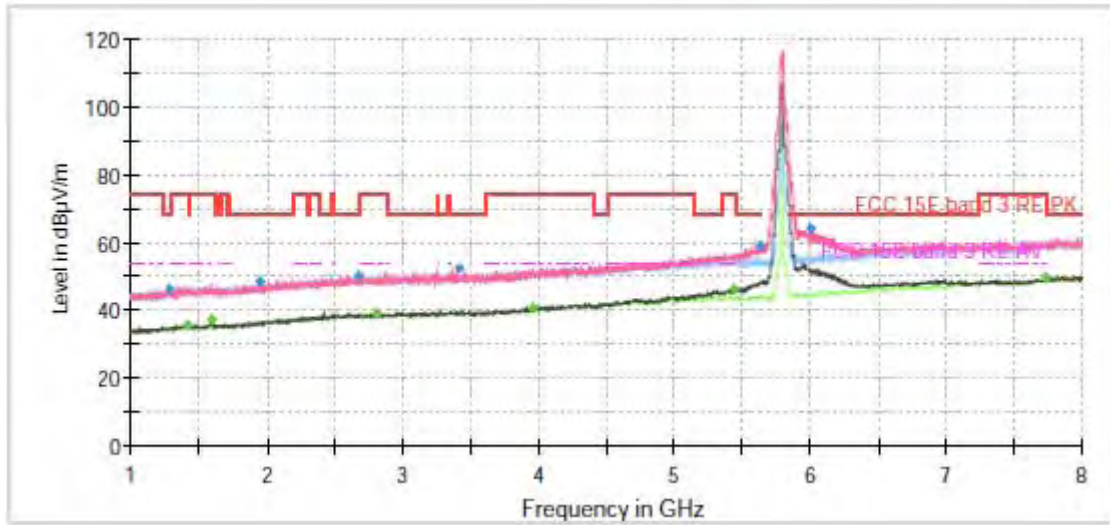

Note: The signal beyond the limit is carrier.
Radiates Emission from 1GHz to 8GHz

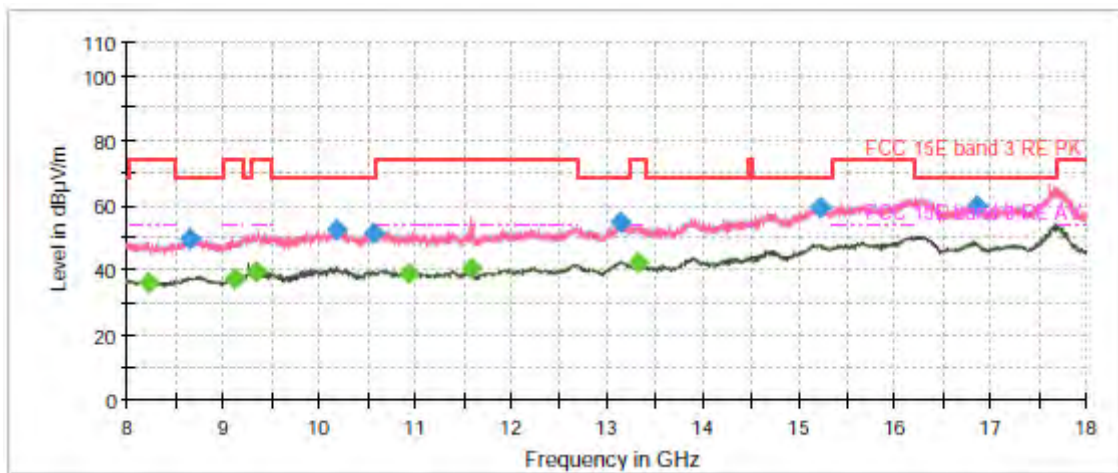

Radiates Emission from 8GHz to 18GHz

Frequency (MHz)	MaxPeak (dB μ V/m)	Average (dB μ V/m)	Limit (dB μ V/m)	Margin (dB)	Meas. Time (ms)	Height (cm)	Pol	Azimuth (deg)	Corr. (dB/m)
1280.88	46.19	---	68.20	22.01	500.00	200.0	H	204.00	-10
1407.75	---	35.66	54.00	18.34	500.00	100.0	V	164.00	-9
1589.75	---	37.18	54.00	16.82	500.00	200.0	V	216.00	-9
1946.75	48.79	---	68.20	19.41	500.00	100.0	H	170.00	-8
2671.25	50.04	---	68.20	18.16	500.00	100.0	H	33.00	-6
2806.88	---	38.89	54.00	15.11	500.00	100.0	V	292.00	-5
3413.25	52.20	---	68.20	16.00	500.00	100.0	V	266.00	-4
3964.50	---	40.97	54.00	13.03	500.00	100.0	V	110.00	-2
5444.13	---	46.32	54.00	7.68	500.00	200.0	V	250.00	3
5625.25	59.31	---	68.20	8.89	500.00	200.0	V	4.00	3
6003.25	64.12	---	68.20	4.08	500.00	200.0	V	346.00	4
7728.75	---	49.56	54.00	4.44	500.00	100.0	H	239.00	9

Remark: 1. Correction Factor = Antenna factor + Insertion loss (cable loss + amplifier gain)

2. Margin = Limit –MAX Peak/ Average

802.11ac (VHT80) CH42

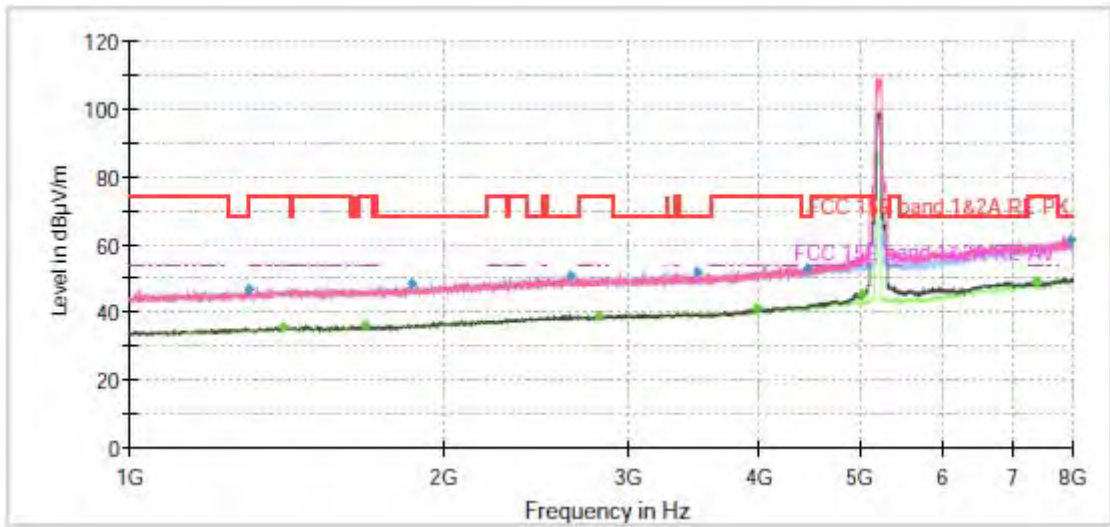

Note: The signal beyond the limit is carrier.
Radiates Emission from 1GHz to 8GHz

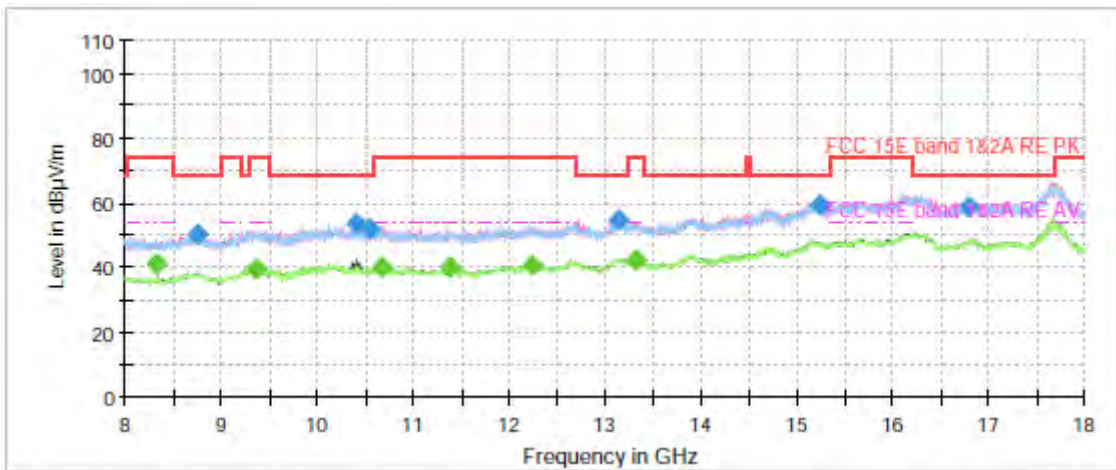

Radiates Emission from 8GHz to 18GHz

Frequency (MHz)	MaxPeak (dB μ V/m)	Average (dB μ V/m)	Limit (dB μ V/m)	Margin (dB)	Meas. Time (ms)	Height (cm)	Pol	Azimuth (deg)	Corr. (dB/m)
1299.25	46.63	---	68.20	21.57	500.00	200.0	V	114.00	-9
1400.75	---	35.95	54.00	18.05	500.00	200.0	V	236.00	-9
1679.88	---	36.04	54.00	17.96	500.00	100.0	V	311.00	-8
1860.13	48.29	---	68.20	19.91	500.00	200.0	V	121.00	-8
2641.50	50.81	---	68.20	17.39	500.00	100.0	V	90.00	-6
2808.63	---	39.14	54.00	14.86	500.00	100.0	H	1.00	-5
3486.75	51.75	---	68.20	16.45	500.00	200.0	H	347.00	-4
3993.38	---	41.11	54.00	12.89	500.00	100.0	V	311.00	-2
4452.75	52.97	---	68.20	15.23	500.00	100.0	V	317.00	0
5031.13	---	45.32	54.00	8.68	500.00	200.0	V	114.00	2
7372.63	---	49.05	54.00	4.95	500.00	200.0	V	0.00	8
7981.63	61.33	---	68.20	6.87	500.00	100.0	V	271.00	9

Remark: 1. Correction Factor = Antenna factor + Insertion loss (cable loss + amplifier gain)

2. Margin = Limit - MAX Peak/ Average

802.11ac (VHT80) CH58

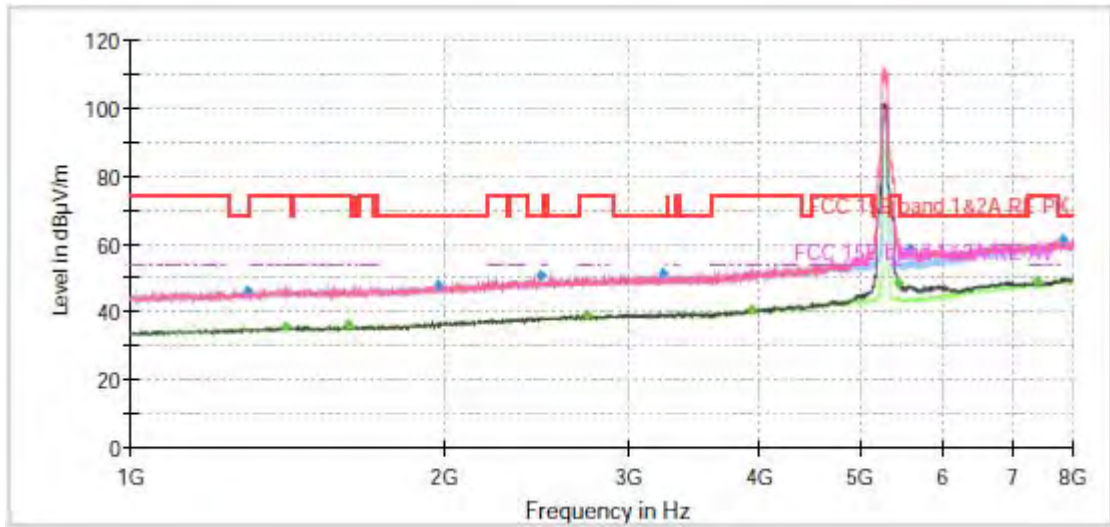

Note: The signal beyond the limit is carrier.
Radiates Emission from 1GHz to 8GHz

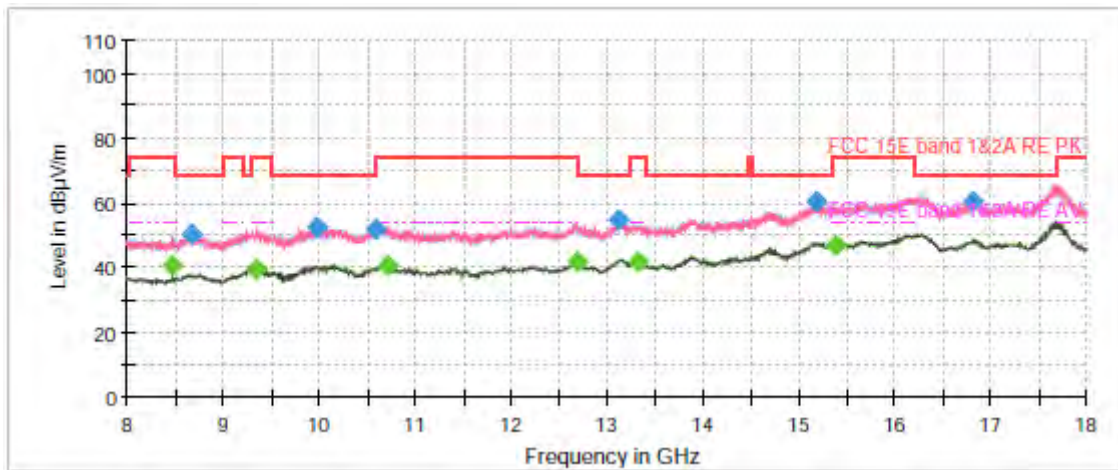

Radiates Emission from 8GHz to 18GHz

Frequency (MHz)	MaxPeak (dB μ V/m)	Average (dB μ V/m)	Limit (dB μ V/m)	Margin (dB)	Meas. Time (ms)	Height (cm)	Pol	Azimuth (deg)	Corr. (dB/m)
1293.13	46.08	---	68.20	22.12	500.00	200.0	H	348.00	-9
1407.75	---	35.67	54.00	18.33	500.00	100.0	V	68.00	-9
1616.00	---	36.07	54.00	17.93	500.00	200.0	V	36.00	-9
1972.13	48.13	---	68.20	20.07	500.00	200.0	V	12.00	-8
2474.38	50.98	---	68.20	17.22	500.00	200.0	H	344.00	-6
2740.38	---	39.22	54.00	14.78	500.00	200.0	H	325.00	-5
3242.63	51.38	---	68.20	16.82	500.00	100.0	V	0.00	-4
3933.88	---	40.92	54.00	13.08	500.00	100.0	V	290.00	-2
5451.13	---	48.57	54.00	5.43	500.00	200.0	V	6.00	3
5594.63	58.48	---	68.20	9.72	500.00	200.0	V	2.00	3
7400.63	---	49.24	54.00	4.76	500.00	200.0	V	43.00	8
7832.00	61.41	---	68.20	6.79	500.00	100.0	H	6.00	9

Remark: 1. Correction Factor = Antenna factor + Insertion loss (cable loss + amplifier gain)

2. Margin = Limit –MAX Peak/ Average

802.11ac (VHT80) CH106

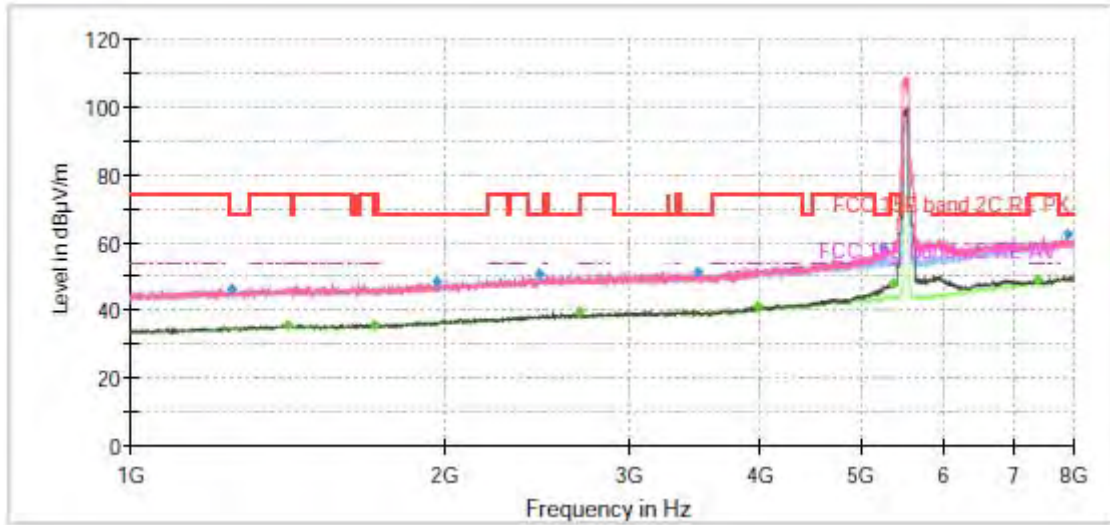

Note: The signal beyond the limit is carrier.
Radiates Emission from 1GHz to 8GHz

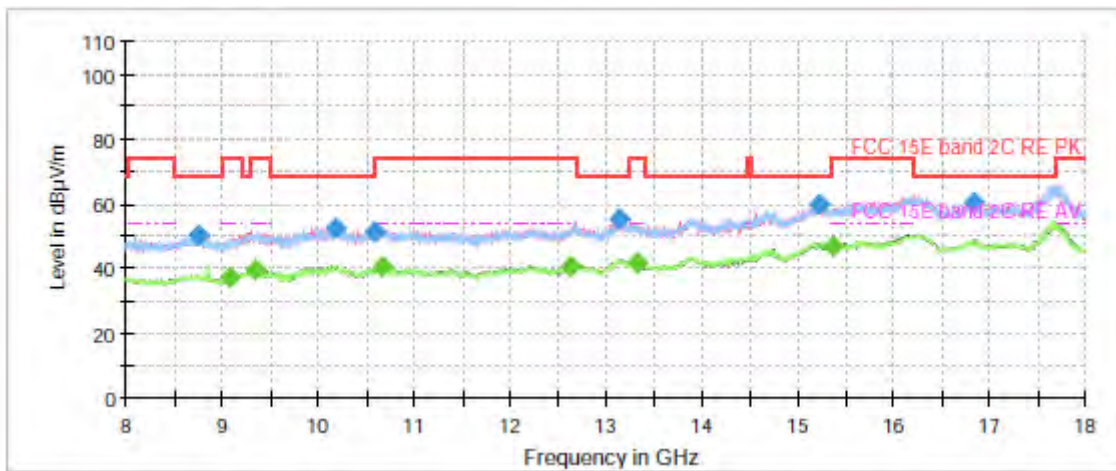

Radiates Emission from 8GHz to 18GHz

Frequency (MHz)	MaxPeak (dB μ V/m)	Average (dB μ V/m)	Limit (dB μ V/m)	Margin (dB)	Meas. Time (ms)	Height (cm)	Pol	Azimuth (deg)	Corr. (dB/m)
1245.88	46.35	---	68.20	21.85	500.00	100.0	V	185.00	-10
1412.13	---	35.97	54.00	18.03	500.00	200.0	V	33.00	-9
1707.00	---	35.90	54.00	18.10	500.00	100.0	V	259.00	-8
1959.88	48.58	---	68.20	19.62	500.00	200.0	V	59.00	-8
2455.13	50.80	---	68.20	17.40	500.00	200.0	H	344.00	-6
2690.50	---	39.42	54.00	14.58	500.00	100.0	H	273.00	-5
3492.88	51.62	---	68.20	16.58	500.00	200.0	V	126.00	-4
3995.13	---	41.33	54.00	12.67	500.00	200.0	V	210.00	-2
5257.75	58.49	---	68.20	9.71	500.00	200.0	V	7.00	3
5371.50	---	47.75	54.00	6.25	500.00	200.0	V	7.00	3
7379.63	---	48.85	54.00	5.15	500.00	100.0	V	252.00	8
7895.00	62.24	---	68.20	5.96	500.00	100.0	V	0.00	9

Remark: 1. Correction Factor = Antenna factor + Insertion loss (cable loss + amplifier gain)

2. Margin = Limit –MAX Peak/ Average

802.11ac (VHT80) CH122

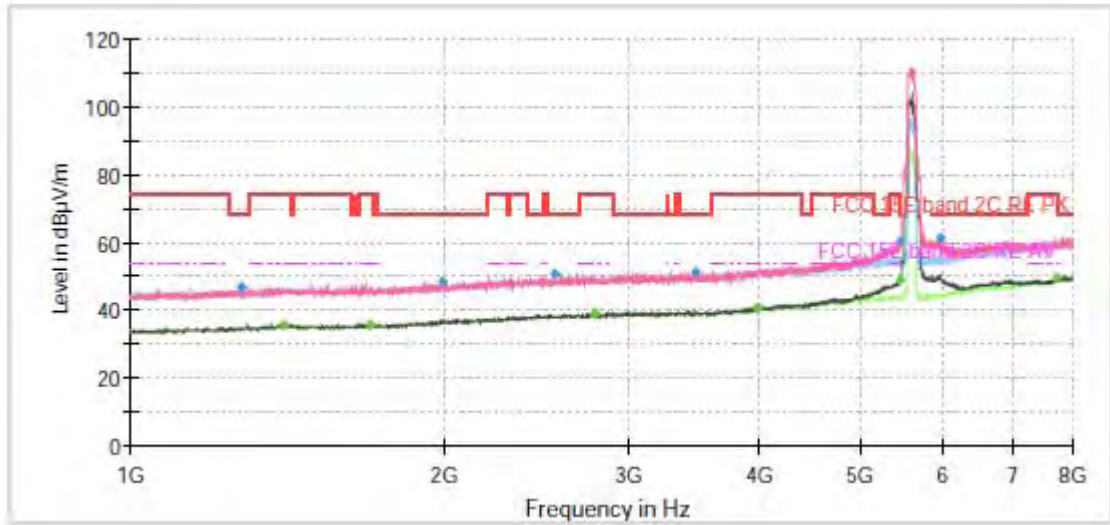

Note: The signal beyond the limit is carrier.
Radiates Emission from 1GHz to 8GHz

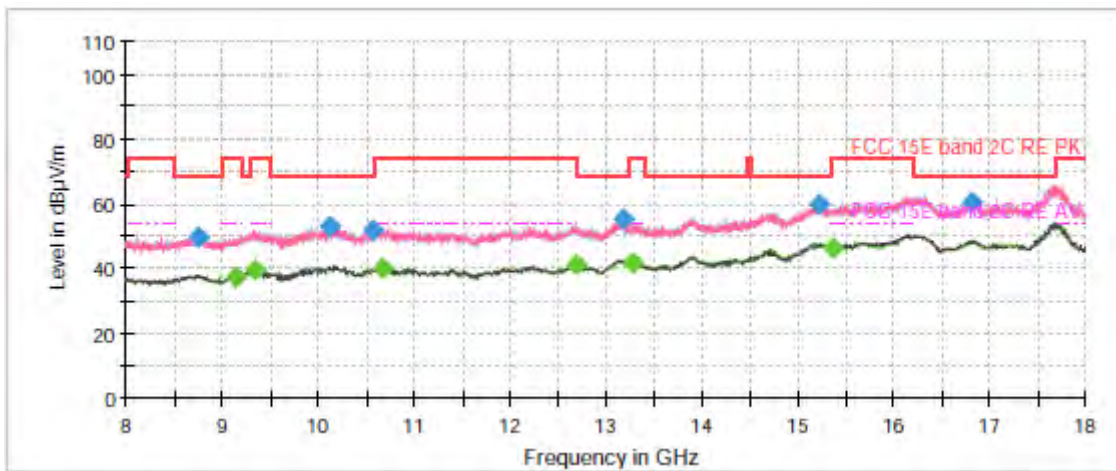

Radiates Emission from 8GHz to 18GHz

Frequency (MHz)	MaxPeak (dB μ V/m)	Average (dB μ V/m)	Limit (dB μ V/m)	Margin (dB)	Meas. Time (ms)	Height (cm)	Pol	Azimuth (deg)	Corr. (dB/m)
1276.50	46.91	---	68.20	21.29	500.00	100.0	H	17.00	-10
1402.50	---	35.77	54.00	18.23	500.00	100.0	H	56.00	-9
1694.75	---	36.00	54.00	18.00	500.00	200.0	H	236.00	-8
1988.75	48.55	---	68.20	19.65	500.00	200.0	H	353.00	-7
2551.38	50.84	---	68.20	17.36	500.00	200.0	V	84.00	-6
2783.25	---	39.15	54.00	14.85	500.00	200.0	V	0.00	-5
3475.38	51.55	---	68.20	16.65	500.00	100.0	V	284.00	-4
3992.50	---	40.86	54.00	13.14	500.00	200.0	H	262.00	-2
5459.88	---	49.02	54.00	4.98	500.00	200.0	V	1.00	3
5465.13	60.04	---	68.20	8.16	500.00	200.0	V	4.00	3
5958.63	61.66	---	68.20	6.54	500.00	200.0	V	347.00	4
7735.75	---	49.59	54.00	4.41	500.00	200.0	H	182.00	9

Remark: 1. Correction Factor = Antenna factor + Insertion loss (cable loss + amplifier gain)

2. Margin = Limit –MAX Peak/ Average

802.11ac (VHT80) CH138

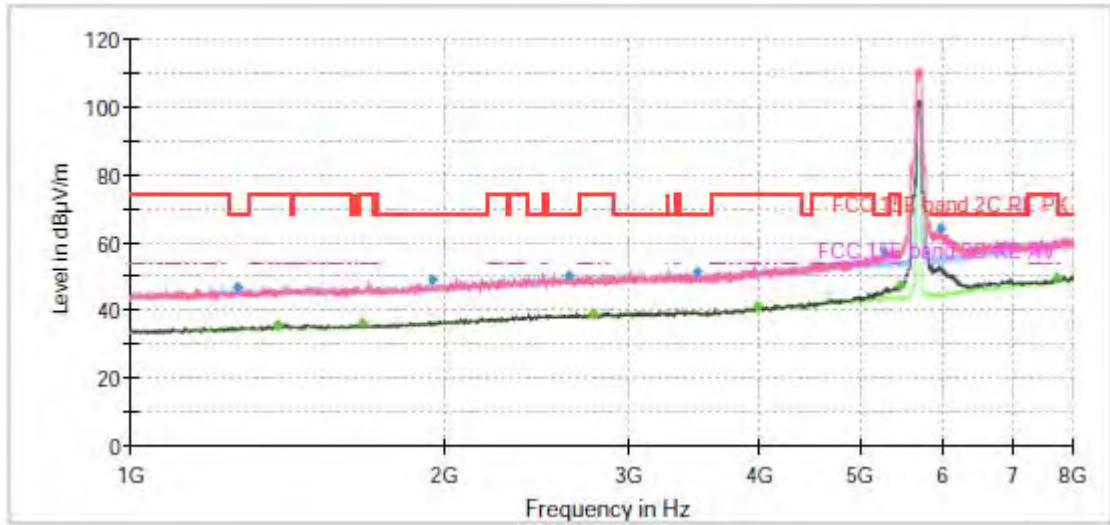

Note: The signal beyond the limit is carrier.
Radiates Emission from 1GHz to 8GHz

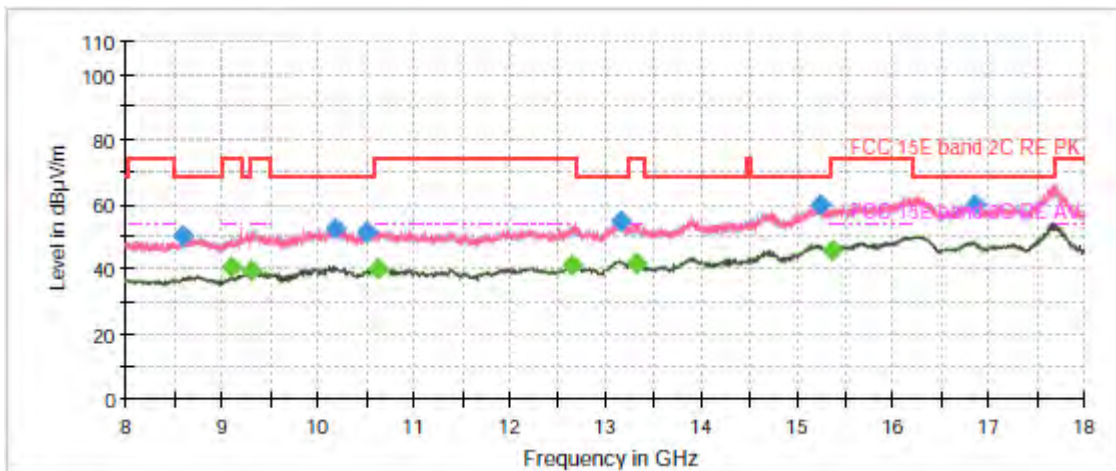

Radiates Emission from 8GHz to 18GHz

Frequency (MHz)	MaxPeak (dB μ V/m)	Average (dB μ V/m)	Limit (dB μ V/m)	Margin (dB)	Meas. Time (ms)	Height (cm)	Pol	Azimuth (deg)	Corr. (dB/m)
1265.13	46.72	---	68.20	21.48	500.00	200.0	V	9.00	-10
1379.75	---	35.68	54.00	18.32	500.00	100.0	H	3.00	-9
1661.50	---	36.11	54.00	17.89	500.00	100.0	V	307.00	-9
1944.13	48.91	---	68.20	19.29	500.00	100.0	V	184.00	-8
2630.13	50.39	---	68.20	17.81	500.00	200.0	V	130.00	-6
2770.13	---	39.04	54.00	14.96	500.00	200.0	H	336.00	-5
3487.63	51.44	---	68.20	16.76	500.00	200.0	V	18.00	-4
3980.25	---	41.09	54.00	12.91	500.00	100.0	V	321.00	-2
5280.50	57.61	---	68.20	10.59	500.00	100.0	V	346.00	3
5458.13	---	47.29	54.00	6.71	500.00	200.0	V	9.00	3
5974.38	64.14	---	68.20	4.06	500.00	200.0	V	346.00	4
7736.63	---	49.51	54.00	4.49	500.00	100.0	H	245.00	9

Remark: 1. Correction Factor = Antenna factor + Insertion loss (cable loss + amplifier gain)

2. Margin = Limit –MAX Peak/ Average

802.11ac (VHT80) CH155

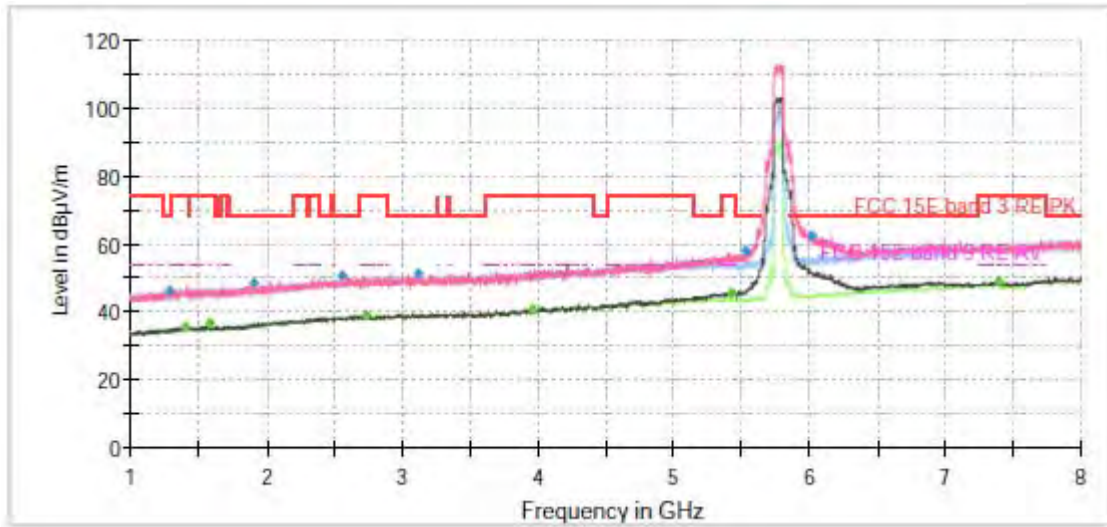

Note: The signal beyond the limit is carrier.
Radiates Emission from 1GHz to 8GHz

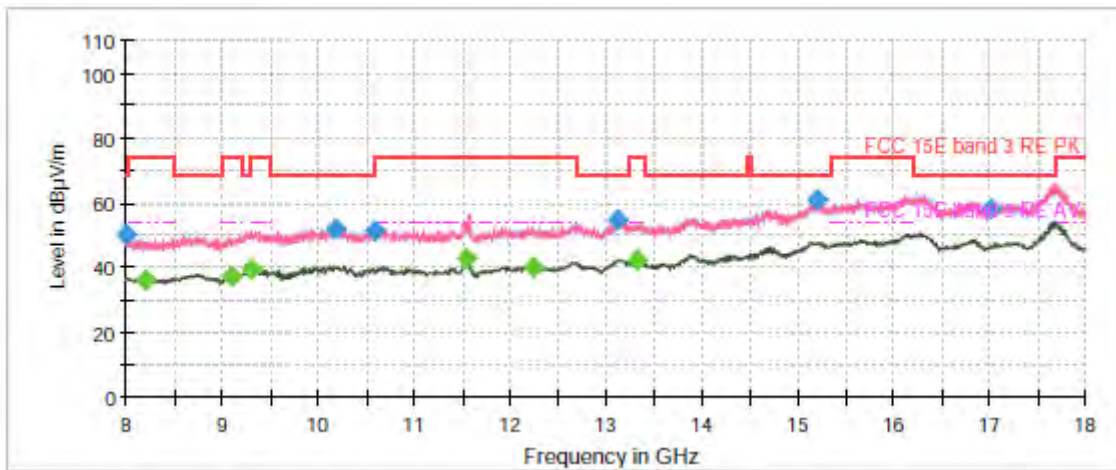

Radiates Emission from 8GHz to 18GHz

Frequency (MHz)	MaxPeak (dB μ V/m)	Average (dB μ V/m)	Limit (dB μ V/m)	Margin (dB)	Meas. Time (ms)	Height (cm)	Pol	Azimuth (deg)	Corr. (dB/m)
1275.63	46.16	---	68.20	22.04	500.00	100.0	V	85.00	-10
1402.50	---	35.68	54.00	18.32	500.00	100.0	H	215.00	-9
1579.25	---	36.73	54.00	17.27	500.00	200.0	V	0.00	-9
1908.25	48.54	---	68.20	19.66	500.00	100.0	H	0.00	-8
2547.00	50.74	---	68.20	17.46	500.00	100.0	H	77.00	-6
2730.75	---	38.97	54.00	15.03	500.00	100.0	H	52.00	-5
3116.63	51.15	---	68.20	17.05	500.00	100.0	V	14.00	-5
3961.88	---	40.74	54.00	13.26	500.00	100.0	V	0.00	-2
5429.25	---	45.90	54.00	8.10	500.00	100.0	V	185.00	3
5527.25	57.99	---	68.20	10.21	500.00	200.0	V	170.00	3
6011.13	62.51	---	68.20	5.69	500.00	200.0	V	0.00	5
7398.88	---	48.98	54.00	5.02	500.00	200.0	V	93.00	8

Remark: 1. Correction Factor = Antenna factor + Insertion loss (cable loss + amplifier gain)

2. Margin = Limit –MAX Peak/ Average

802.11ax (HE20) CH36

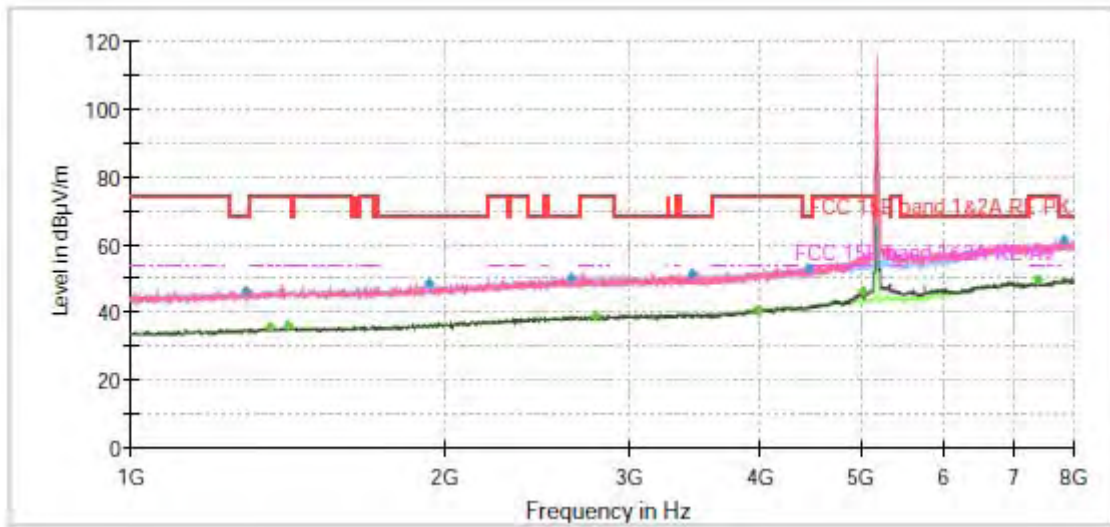

Note: The signal beyond the limit is carrier.
Radiates Emission from 1GHz to 8GHz

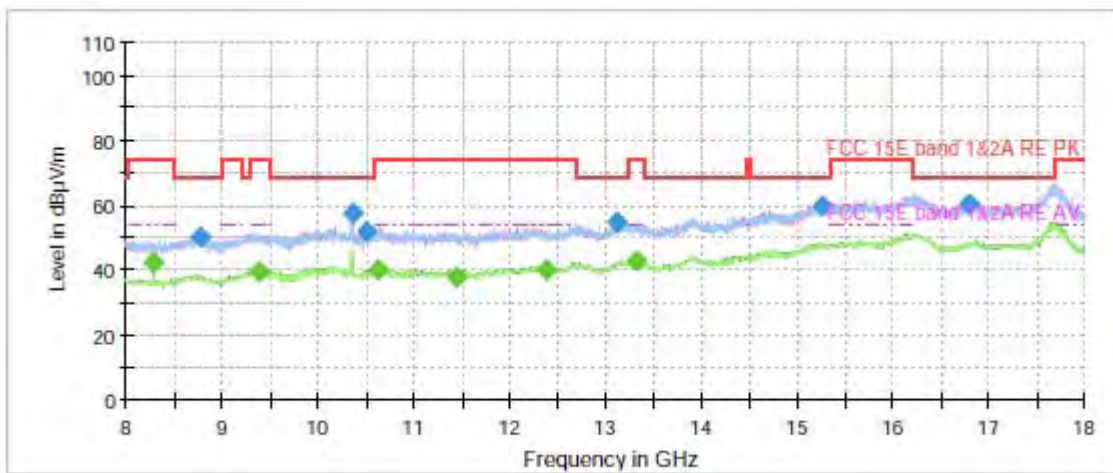

Radiates Emission from 8GHz to 18GHz

Frequency (MHz)	MaxPeak (dB μ V/m)	Average (dB μ V/m)	Limit (dB μ V/m)	Margin (dB)	Meas. Time (ms)	Height (cm)	Pol	Azimuth (deg)	Corr. (dB/m)
1289.63	46.57	---	68.20	21.63	500.00	200.0	H	349.00	-9
1357.00	---	35.58	54.00	18.42	500.00	200.0	H	165.00	-9
1415.63	---	36.11	54.00	17.89	500.00	100.0	H	105.00	-9
1925.75	48.33	---	68.20	19.87	500.00	200.0	H	307.00	-8
2637.13	50.49	---	68.20	17.71	500.00	200.0	H	349.00	-6
2785.00	---	39.03	54.00	14.97	500.00	200.0	V	243.00	-5
3442.13	51.35	---	68.20	16.85	500.00	100.0	V	352.00	-4
3979.38	---	40.98	54.00	13.02	500.00	200.0	H	352.00	-2
4448.38	52.89	---	68.20	15.31	500.00	200.0	H	345.00	-1
5021.50	---	46.26	54.00	7.74	500.00	200.0	V	122.00	2
7370.00	---	49.43	54.00	4.57	500.00	200.0	V	99.00	8
7825.00	61.47	---	68.20	6.73	500.00	100.0	V	69.00	9

Remark: 1. Correction Factor = Antenna factor + Insertion loss (cable loss + amplifier gain)

2. Margin = Limit - MAX Peak/ Average

802.11ax (HE20) CH40

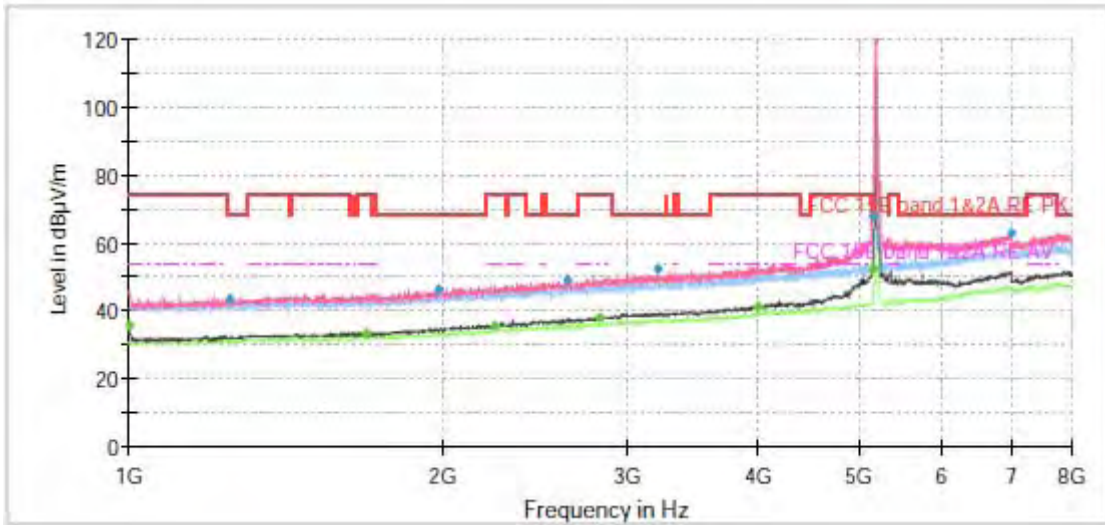

Note: The signal beyond the limit is carrier.
Radiates Emission from 1GHz to 8GHz

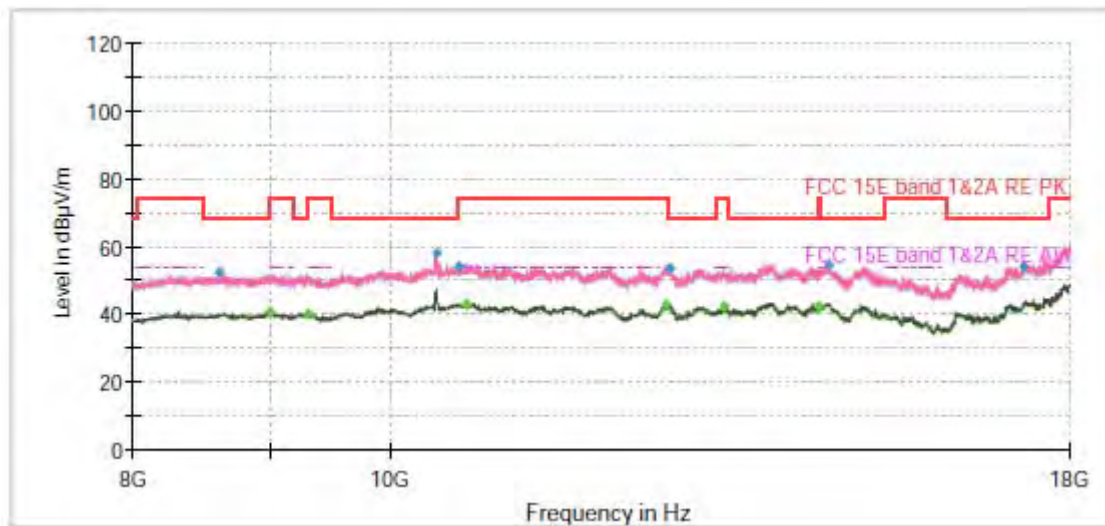

Radiates Emission from 8GHz to 18GHz

Frequency (MHz)	MaxPeak (dB μ V/m)	Average (dB μ V/m)	Limit (dB μ V/m)	Margin (dB)	Meas. Time (ms)	Height (cm)	Pol	Azimuth (deg)	Corr. (dB/m)
1000.00	---	35.61	54.00	18.39	500.00	200.0	V	145.00	-3
1249.38	43.72	---	68.20	24.48	500.00	100.0	V	10.00	-2
1688.63	---	33.62	54.00	20.38	500.00	100.0	V	24.00	-1
1979.13	46.30	---	68.20	21.90	500.00	100.0	V	31.00	1
2240.75	---	35.79	54.00	18.21	500.00	200.0	V	28.00	2
2632.75	49.14	---	68.20	19.06	500.00	100.0	V	0.00	4
2818.25	---	38.16	54.00	15.84	500.00	100.0	V	319.00	4
3212.00	52.59	---	68.20	15.61	500.00	100.0	V	45.00	5
3997.75	---	41.53	54.00	12.47	500.00	200.0	V	357.00	6
5146.63	68.23	---	74.00	5.77	500.00	100.0	V	5.00	10
5148.38	---	52.48	54.00	1.52	500.00	200.0	V	186.00	10
6999.88	63.18	---	68.20	5.02	500.00	200.0	V	359.00	14

Remark: 1. Correction Factor = Antenna factor + Insertion loss (cable loss + amplifier gain)

2. Margin = Limit –MAX Peak/ Average

802.11ax (HE20) CH48

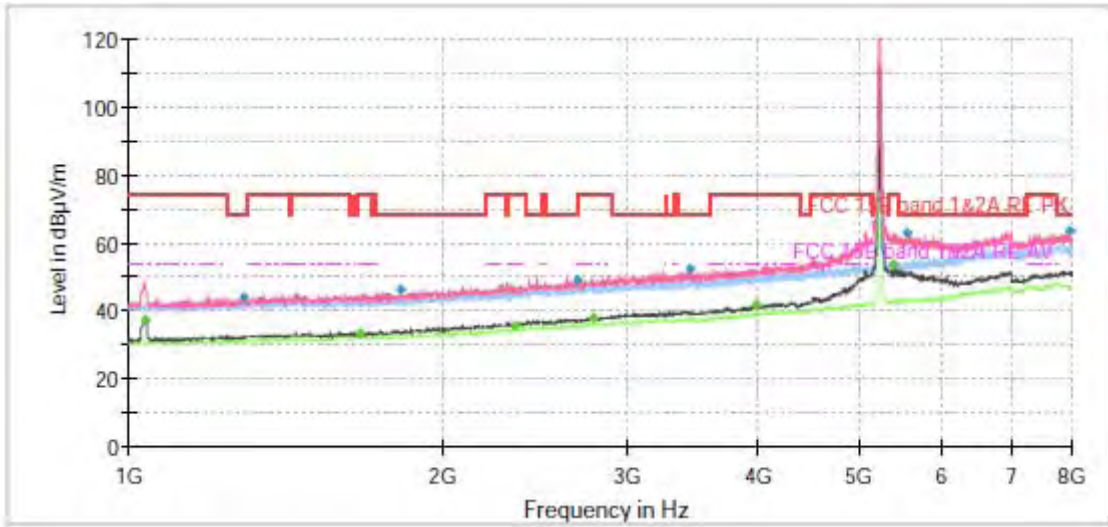

Note: The signal beyond the limit is carrier.
Radiates Emission from 1GHz to 8GHz

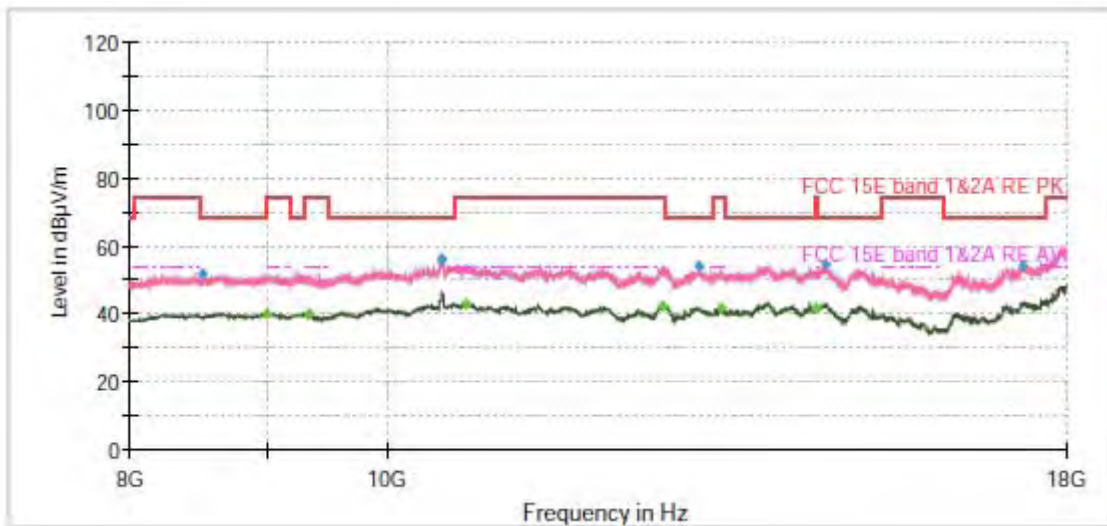

Radiates Emission from 8GHz to 18GHz

Frequency (MHz)	MaxPeak (dB μ V/m)	Average (dB μ V/m)	Limit (dB μ V/m)	Margin (dB)	Meas. Time (ms)	Height (cm)	Pol	Azimuth (deg)	Corr. (dB/m)
1036.75	---	37.65	54.00	16.35	500.00	200.0	V	202.00	-3
1289.63	43.92	---	68.20	24.28	500.00	100.0	V	5.00	-2
1662.38	---	33.71	54.00	20.29	500.00	100.0	V	318.00	-1
1819.00	46.33	---	68.20	21.87	500.00	100.0	V	146.00	0
2344.88	---	35.99	54.00	18.01	500.00	200.0	V	90.00	2
2685.25	49.01	---	68.20	19.19	500.00	100.0	V	19.00	4
2785.88	---	38.21	54.00	15.79	500.00	200.0	V	348.00	4
3450.00	52.41	---	68.20	15.79	500.00	200.0	V	174.00	5
3990.75	---	41.65	54.00	12.35	500.00	200.0	V	291.00	6
5400.38	---	53.32	54.00	0.68	500.00	200.0	V	167.00	11
5571.88	62.83	---	68.20	5.37	500.00	200.0	V	126.00	12
7975.50	63.68	---	68.20	4.52	500.00	100.0	V	0.00	17

Remark: 1. Correction Factor = Antenna factor + Insertion loss (cable loss + amplifier gain)

2. Margin = Limit - MAX Peak/ Average

802.11ax (HE20) CH52

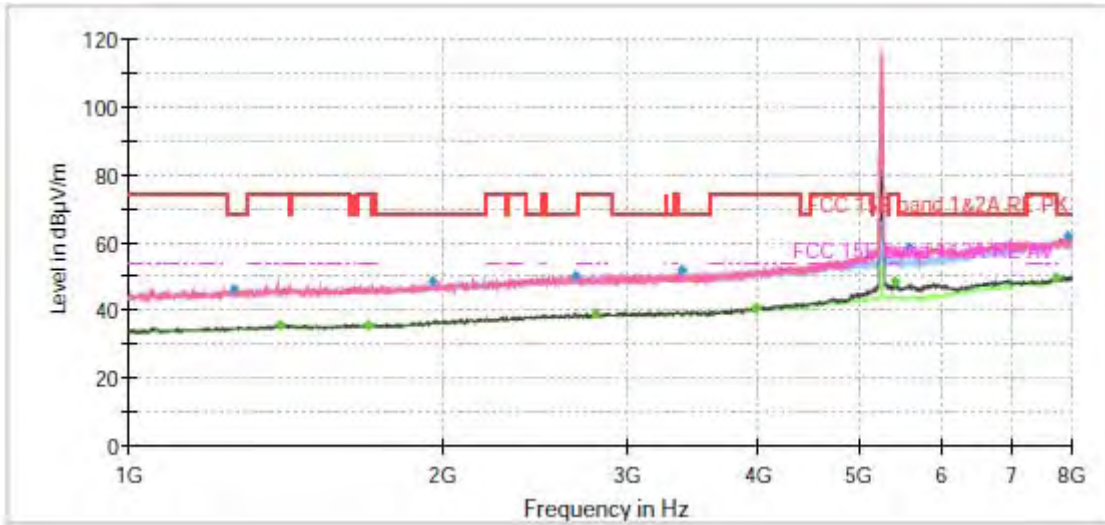

Note: The signal beyond the limit is carrier.
Radiates Emission from 1GHz to 8GHz

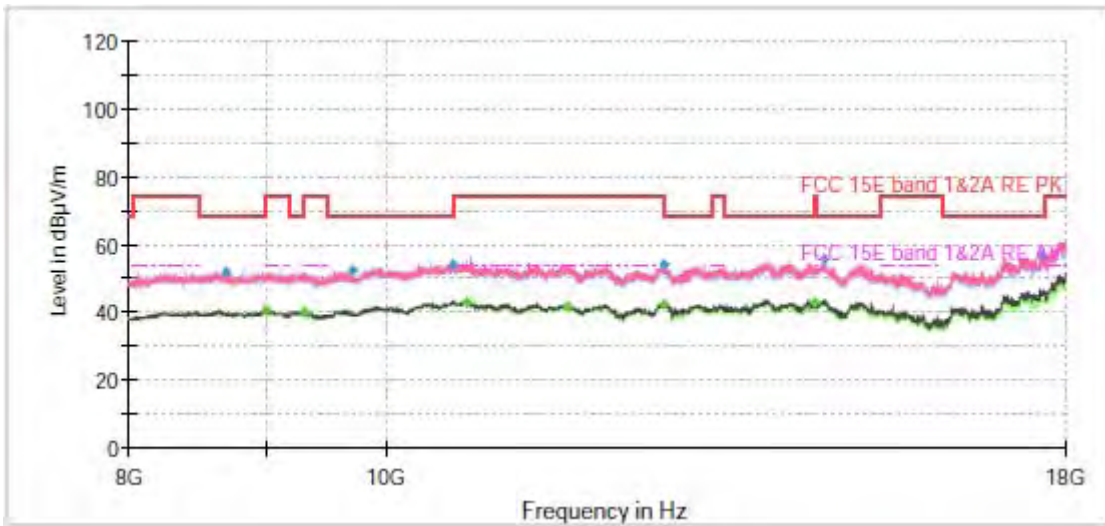

Radiates Emission from 8GHz to 18GHz

Frequency (MHz)	MaxPeak (dB μ V/m)	Average (dB μ V/m)	Limit (dB μ V/m)	Margin (dB)	Meas. Time (ms)	Height (cm)	Pol	Azimuth (deg)	Corr. (dB/m)
1260.75	46.44	---	68.20	21.76	500.00	200.0	H	312.00	-10
1392.88	---	35.75	54.00	18.25	500.00	200.0	H	0.00	-9
1697.38	---	35.88	54.00	18.12	500.00	100.0	H	2.00	-8
1954.63	48.37	---	68.20	19.83	500.00	200.0	V	0.00	-8
2674.75	50.38	---	68.20	17.82	500.00	200.0	H	176.00	-6
2792.00	---	38.93	54.00	15.07	500.00	200.0	H	217.00	-5
3391.38	51.74	---	68.20	16.46	500.00	100.0	V	0.00	-4
3996.88	---	40.91	54.00	13.09	500.00	100.0	H	300.00	-2
5424.00	---	48.60	54.00	5.40	500.00	200.0	V	332.00	3
5597.25	58.82	---	68.20	9.38	500.00	200.0	V	0.00	3
7713.88	---	49.57	54.00	4.43	500.00	200.0	V	278.00	9
7917.75	61.81	---	68.20	6.39	500.00	200.0	H	108.00	9

Remark: 1. Correction Factor = Antenna factor + Insertion loss (cable loss + amplifier gain)

2. Margin = Limit –MAX Peak/ Average

802.11ax (HE20) CH60

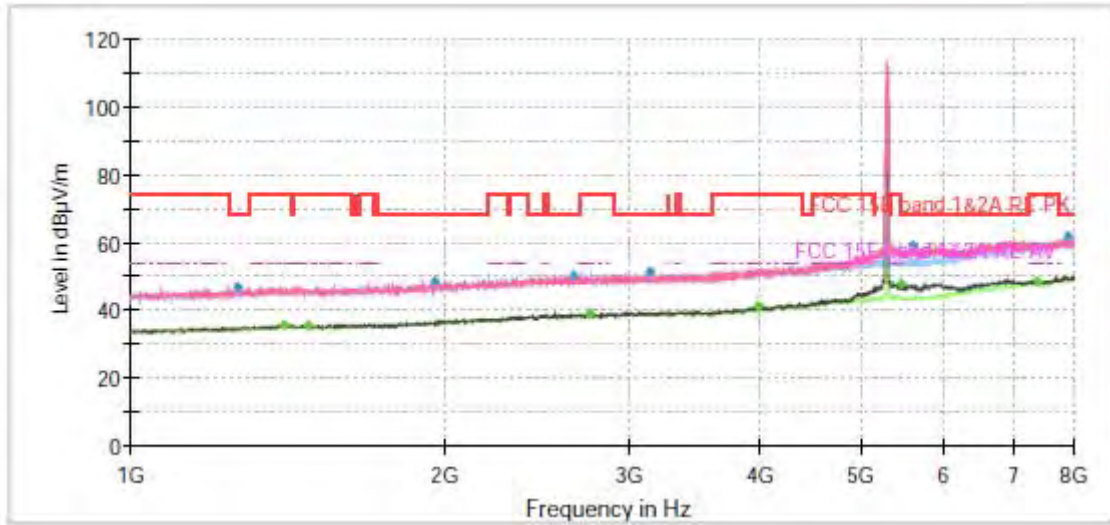

Note: The signal beyond the limit is carrier.
Radiates Emission from 1GHz to 8GHz

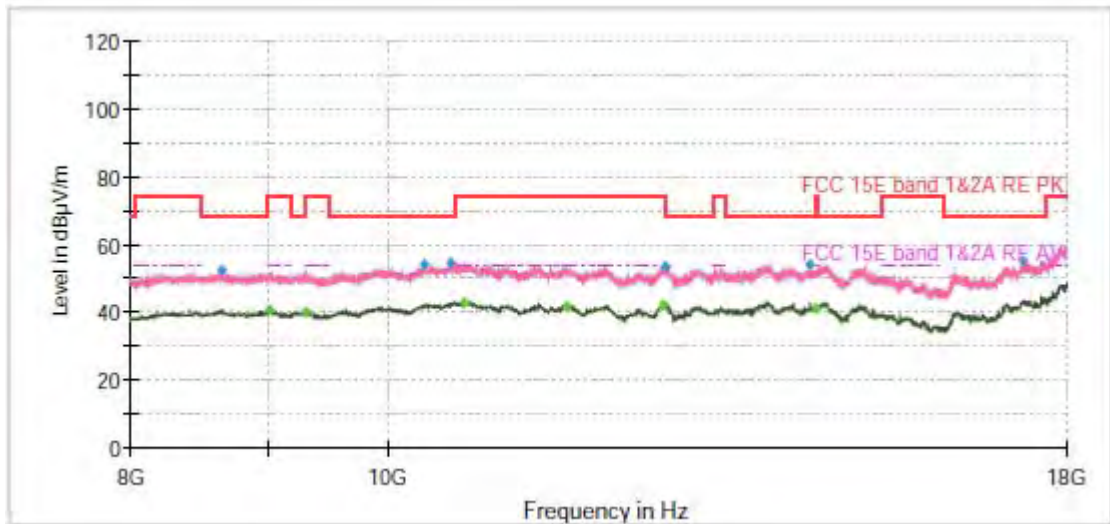

Radiates Emission from 8GHz to 18GHz

Frequency (MHz)	MaxPeak (dB μ V/m)	Average (dB μ V/m)	Limit (dB μ V/m)	Margin (dB)	Meas. Time (ms)	Height (cm)	Pol	Azimuth (deg)	Corr. (dB/m)
1265.13	46.81	---	68.20	21.39	500.00	100.0	V	330.00	-10
1403.38	---	35.65	54.00	18.35	500.00	100.0	V	0.00	-9
1476.88	---	35.93	54.00	18.07	500.00	200.0	V	73.00	-9
1949.38	48.50	---	68.20	19.70	500.00	200.0	V	114.00	-8
2656.38	50.38	---	68.20	17.82	500.00	200.0	H	342.00	-6
2742.13	---	39.02	54.00	14.98	500.00	200.0	H	215.00	-5
3137.63	51.40	---	68.20	16.80	500.00	100.0	V	354.00	-5
3982.00	---	41.04	54.00	12.96	500.00	200.0	V	160.00	-2
5458.13	---	48.10	54.00	5.90	500.00	200.0	V	316.00	3
5617.38	59.18	---	68.20	9.02	500.00	200.0	V	194.00	3
7385.75	---	48.83	54.00	5.17	500.00	100.0	V	324.00	8
7909.88	61.93	---	68.20	6.27	500.00	100.0	V	343.00	9

Remark: 1. Correction Factor = Antenna factor + Insertion loss (cable loss + amplifier gain)

2. Margin = Limit –MAX Peak/ Average

802.11ax (HE20) CH64

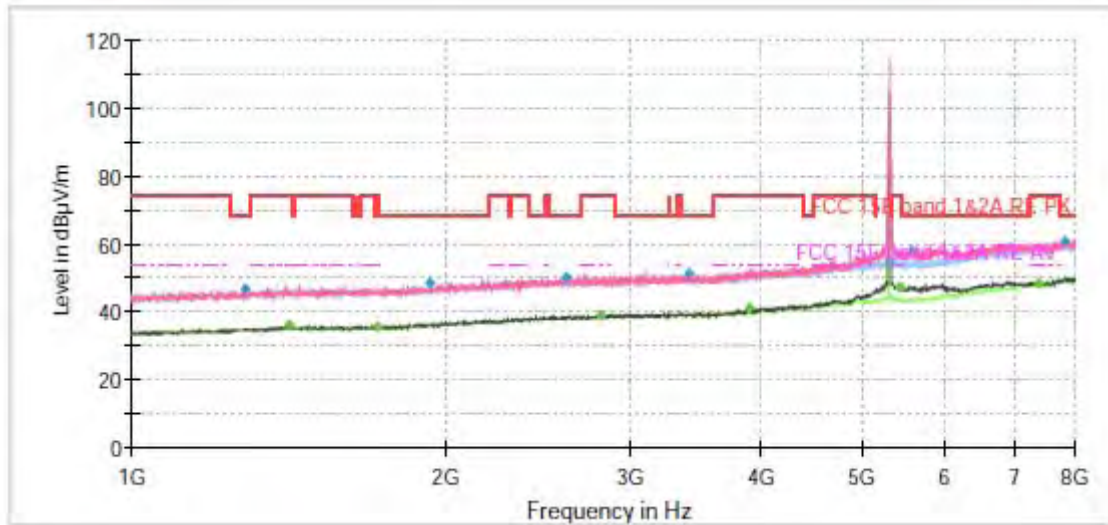

Note: The signal beyond the limit is carrier.
Radiates Emission from 1GHz to 8GHz

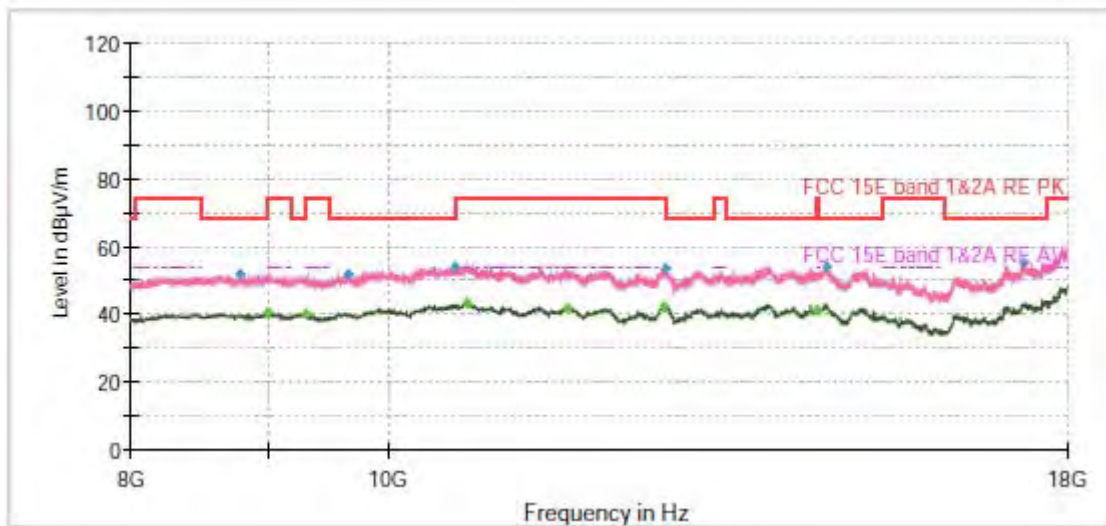

Radiates Emission from 8GHz to 18GHz

Frequency (MHz)	MaxPeak (dB μ V/m)	Average (dB μ V/m)	Limit (dB μ V/m)	Margin (dB)	Meas. Time (ms)	Height (cm)	Pol	Azimuth (deg)	Corr. (dB/m)
1280.88	46.76	---	68.20	21.44	500.00	200.0	V	92.00	-10
1410.38	---	36.10	54.00	17.90	500.00	100.0	H	56.00	-9
1719.25	---	35.88	54.00	18.12	500.00	100.0	V	193.00	-8
1929.25	48.44	---	68.20	19.76	500.00	200.0	H	275.00	-8
2606.50	50.06	---	68.20	18.14	500.00	200.0	H	336.00	-6
2814.75	---	38.94	54.00	15.06	500.00	200.0	H	116.00	-5
3416.75	51.47	---	68.20	16.73	500.00	100.0	H	103.00	-4
3909.38	---	41.23	54.00	12.77	500.00	100.0	V	319.00	-2
5445.00	---	47.26	54.00	6.74	500.00	200.0	V	5.00	3
5574.50	58.27	---	68.20	9.93	500.00	200.0	V	0.00	3
7370.88	---	48.62	54.00	5.38	500.00	100.0	V	349.00	8
7828.50	60.88	---	68.20	7.32	500.00	200.0	V	92.00	9

Remark: 1. Correction Factor = Antenna factor + Insertion loss (cable loss + amplifier gain)

2. Margin = Limit –MAX Peak/ Average

802.11ax (HE20) CH100

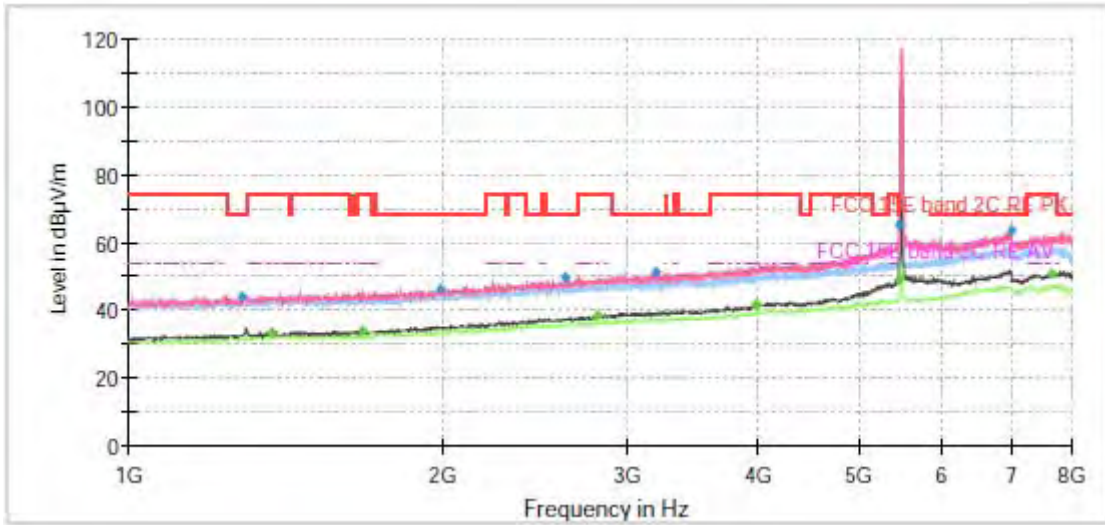

Note: The signal beyond the limit is carrier.
Radiates Emission from 1GHz to 8GHz

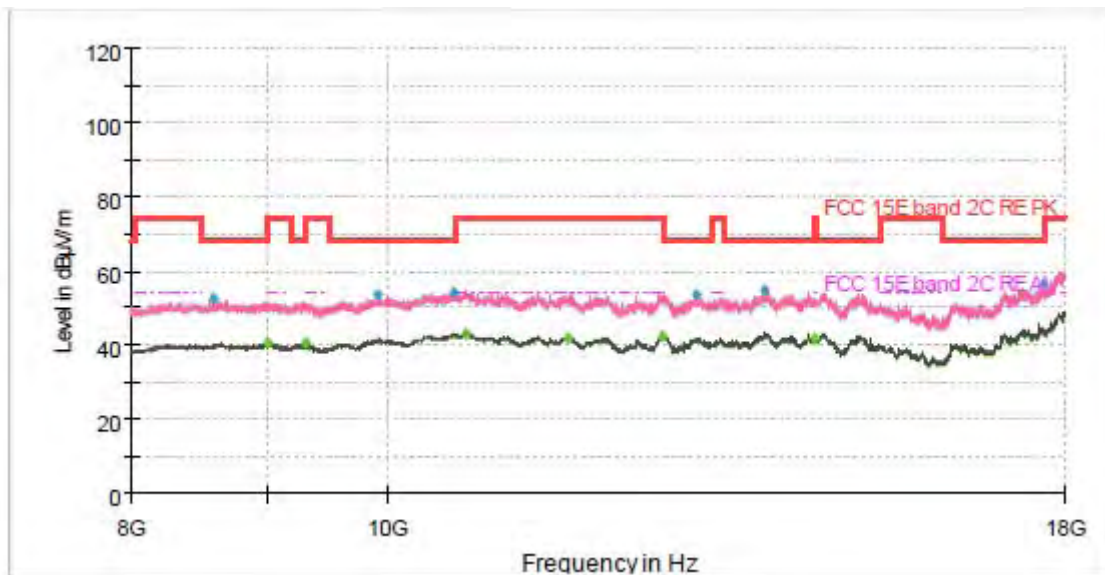

Radiates Emission from 8GHz to 18GHz

Frequency (MHz)	MaxPeak (dB μ V/m)	Average (dB μ V/m)	Limit (dB μ V/m)	Margin (dB)	Meas. Time (ms)	Height (cm)	Pol	Azimuth (deg)	Corr. (dB/m)
1281.75	44.37	---	68.20	23.83	500.00	100.0	V	143.00	-2
1368.38	---	33.57	54.00	20.43	500.00	200.0	V	359.00	-1
1670.25	---	33.93	54.00	20.07	500.00	200.0	V	185.00	-1
1985.25	46.32	---	68.20	21.88	500.00	100.0	V	50.00	1
2618.75	49.45	---	68.20	18.75	500.00	200.0	V	238.00	4
2812.13	---	38.46	54.00	15.54	500.00	200.0	V	165.00	4
3198.00	51.18	---	68.20	17.02	500.00	200.0	V	359.00	5
3996.88	---	41.78	54.00	12.22	500.00	200.0	V	205.00	6
5459.88	---	49.13	54.00	4.87	500.00	100.0	V	6.00	11
5469.50	65.55	---	68.20	2.65	500.00	200.0	V	165.00	11
6992.88	63.76	---	68.20	4.44	500.00	100.0	V	6.00	14
7661.38	---	50.88	54.00	3.12	500.00	100.0	V	103.00	17

Remark: 1. Correction Factor = Antenna factor + Insertion loss (cable loss + amplifier gain)

2. Margin = Limit –MAX Peak/ Average

802.11ax (HE20) CH120

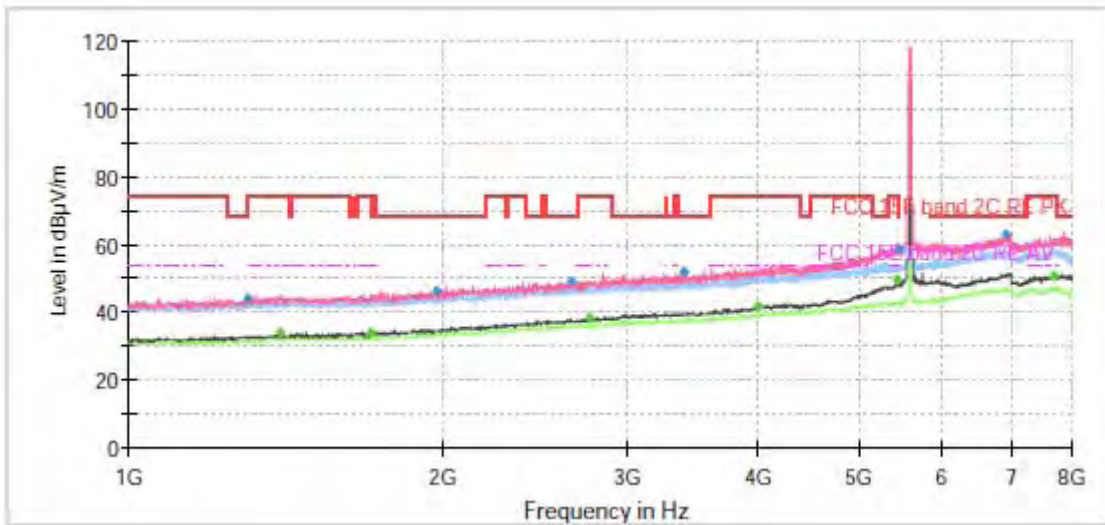

Note: The signal beyond the limit is carrier.
Radiates Emission from 1GHz to 8GHz

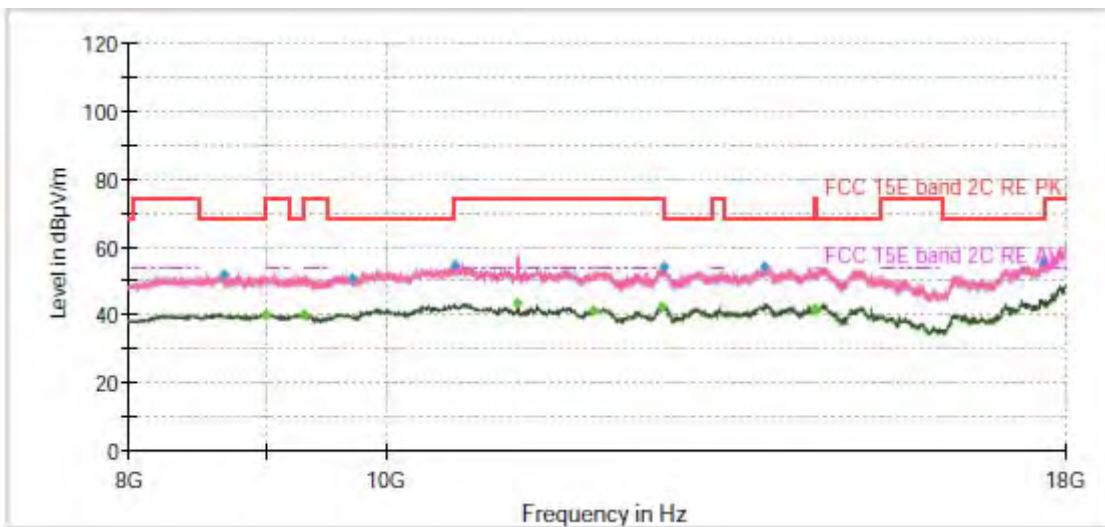

Radiates Emission from 8GHz to 18GHz

Frequency (MHz)	MaxPeak (dB μ V/m)	Average (dB μ V/m)	Limit (dB μ V/m)	Margin (dB)	Meas. Time (ms)	Height (cm)	Pol	Azimuth (deg)	Corr. (dB/m)
1296.63	44.02	---	68.20	24.18	500.00	200.0	H	167.00	-1
1394.63	---	33.98	54.00	20.02	500.00	200.0	V	179.00	-1
1704.38	---	34.05	54.00	19.95	500.00	100.0	V	27.00	-1
1970.38	46.38	---	68.20	21.82	500.00	100.0	V	148.00	1
2649.38	49.33	---	68.20	18.87	500.00	200.0	V	0.00	4
2763.13	---	38.42	54.00	15.58	500.00	200.0	V	42.00	4
3407.13	51.88	---	68.20	16.32	500.00	200.0	V	276.00	5
3998.63	---	41.89	54.00	12.11	500.00	200.0	V	359.00	6
5443.25	---	49.80	54.00	4.20	500.00	200.0	V	151.00	11
5460.75	58.55	---	68.20	9.65	500.00	200.0	V	199.00	11
6912.38	63.22	---	68.20	4.98	500.00	100.0	V	1.00	13
7698.13	---	50.91	54.00	3.09	500.00	100.0	V	4.00	17

Remark: 1. Correction Factor = Antenna factor + Insertion loss (cable loss + amplifier gain)

2. Margin = Limit –MAX Peak/ Average

802.11ax (HE20) CH140

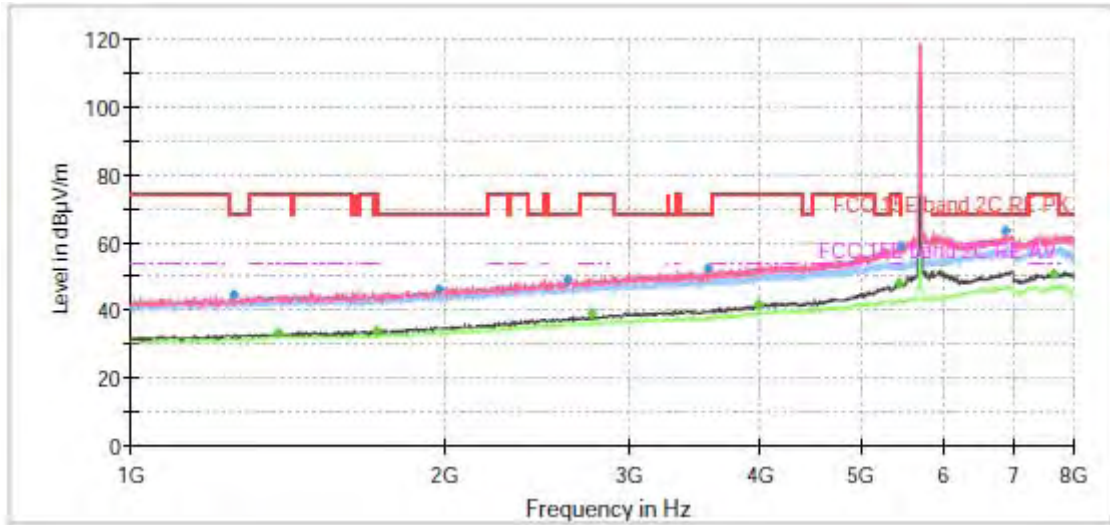

Note: The signal beyond the limit is carrier.
Radiates Emission from 1GHz to 8GHz

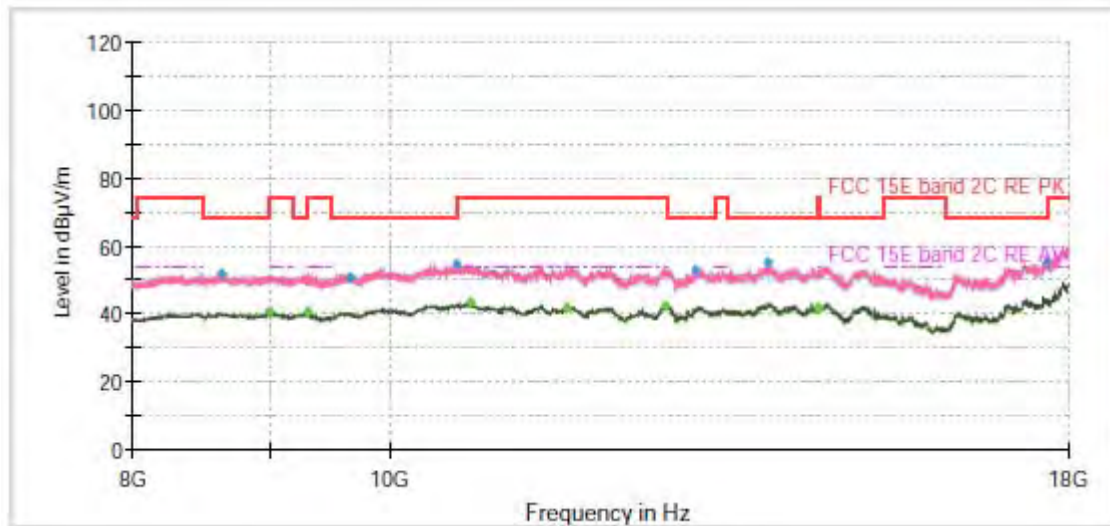

Radiates Emission from 8GHz to 18GHz

Frequency (MHz)	MaxPeak (dB μ V/m)	Average (dB μ V/m)	Limit (dB μ V/m)	Margin (dB)	Meas. Time (ms)	Height (cm)	Pol	Azimuth (deg)	Corr. (dB/m)
1252.88	44.44	---	68.20	23.76	500.00	100.0	V	31.00	-2
1379.75	---	33.36	54.00	20.64	500.00	100.0	V	122.00	-1
1719.25	---	34.06	54.00	19.94	500.00	100.0	V	172.00	0
1971.25	46.33	---	68.20	21.87	500.00	100.0	V	7.00	1
2617.00	49.29	---	68.20	18.91	500.00	200.0	V	232.00	4
2761.38	---	38.80	54.00	15.20	500.00	100.0	V	172.00	4
3569.88	52.28	---	68.20	15.92	500.00	100.0	V	2.00	5
3995.13	---	41.58	54.00	12.42	500.00	100.0	V	273.00	6
5438.88	---	47.77	54.00	6.23	500.00	100.0	V	3.00	11
5466.00	58.90	---	68.20	9.30	500.00	200.0	V	173.00	11
6887.00	63.72	---	68.20	4.48	500.00	100.0	V	3.00	13
7648.25	---	50.82	54.00	3.18	500.00	100.0	V	279.00	17

Remark: 1. Correction Factor = Antenna factor + Insertion loss (cable loss + amplifier gain)

2. Margin = Limit –MAX Peak/ Average

802.11ax (HE20) CH144

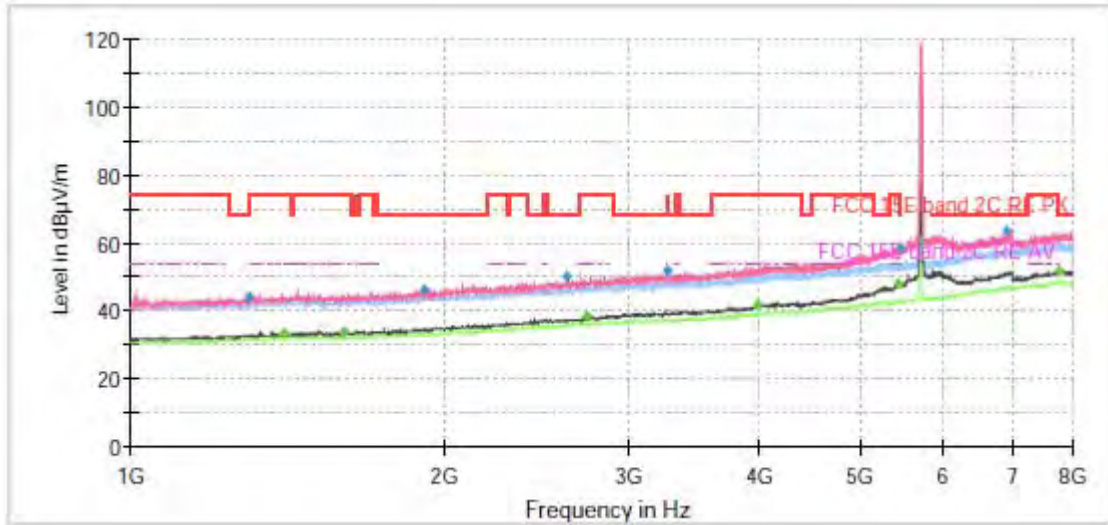

Note: The signal beyond the limit is carrier.
Radiates Emission from 1GHz to 8GHz

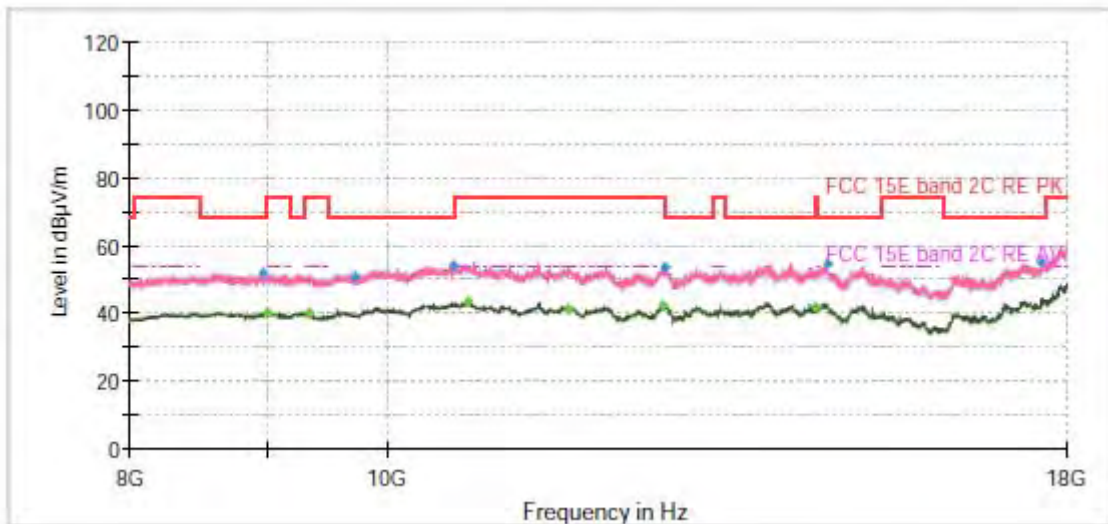

Radiates Emission from 8GHz to 18GHz

Frequency (MHz)	MaxPeak (dB μ V/m)	Average (dB μ V/m)	Limit (dB μ V/m)	Margin (dB)	Meas. Time (ms)	Height (cm)	Pol	Azimuth (deg)	Corr. (dB/m)
1297.50	44.05	---	68.20	24.15	500.00	100.0	V	277.00	-1
1402.50	---	33.61	54.00	20.39	500.00	100.0	V	324.00	-1
1602.00	---	34.00	54.00	20.00	500.00	200.0	V	0.00	-1
1910.00	46.15	---	68.20	22.05	500.00	200.0	V	196.00	0
2622.25	50.09	---	68.20	18.11	500.00	100.0	V	338.00	4
2733.38	---	38.35	54.00	15.65	500.00	100.0	V	290.00	4
3267.13	51.96	---	68.20	16.24	500.00	200.0	H	135.00	5
3981.13	---	41.58	54.00	12.42	500.00	200.0	V	142.00	6
5451.13	---	47.81	54.00	6.19	500.00	200.0	V	182.00	11
5462.50	58.60	---	68.20	9.60	500.00	100.0	V	1.00	11
6923.75	63.59	---	68.20	4.61	500.00	200.0	V	148.00	13
7743.63	---	51.72	54.00	2.28	500.00	100.0	V	257.00	17

Remark: 1. Correction Factor = Antenna factor + Insertion loss (cable loss + amplifier gain)

2. Margin = Limit –MAX Peak/ Average

802.11ax (HE20) CH149

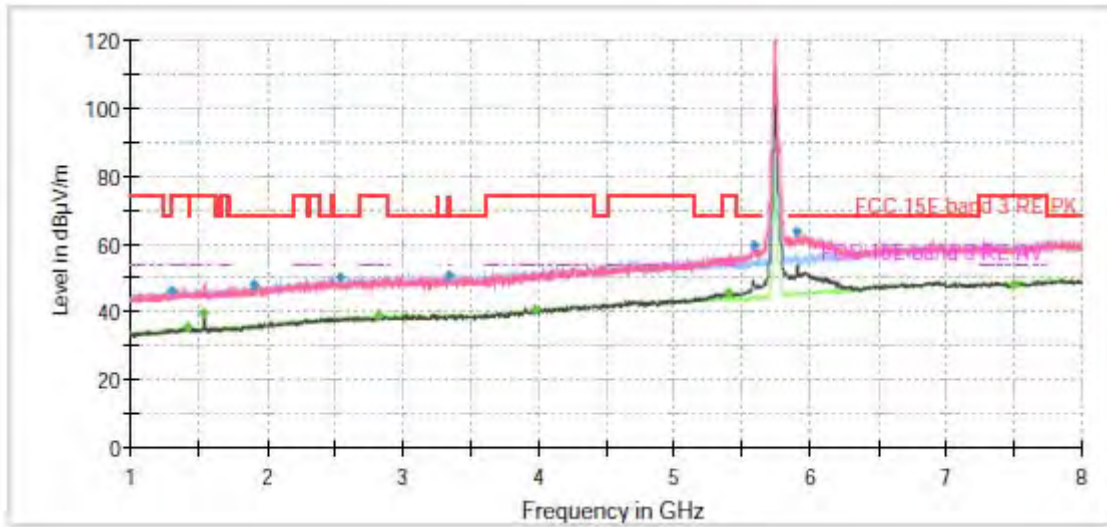

Note: The signal beyond the limit is carrier.
Radiates Emission from 1GHz to 8GHz

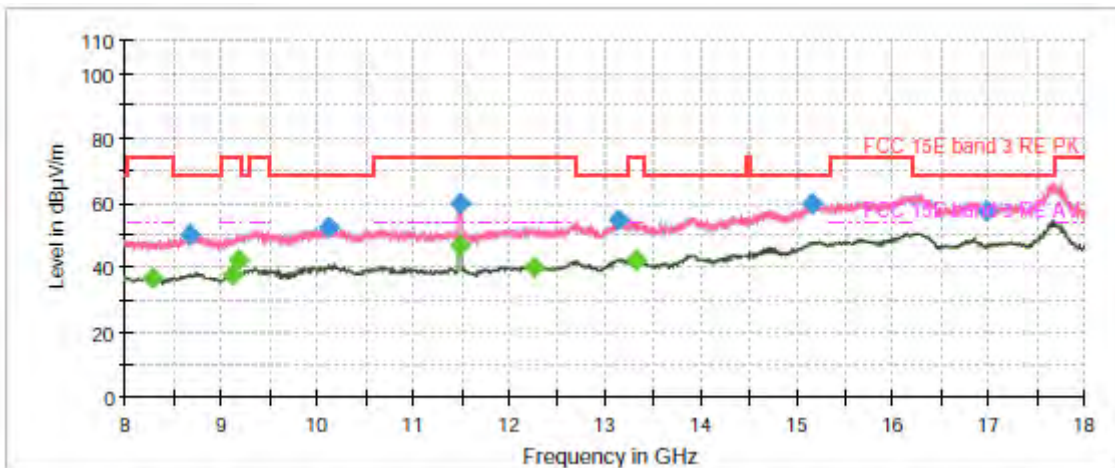

Radiates Emission from 8GHz to 18GHz

Frequency (MHz)	MaxPeak (dB μ V/m)	Average (dB μ V/m)	Limit (dB μ V/m)	Margin (dB)	Meas. Time (ms)	Height (cm)	Pol	Azimuth (deg)	Corr. (dB/m)
1298.38	46.05	---	68.20	22.15	500.00	100.0	H	2.00	-9
1408.63	---	35.59	54.00	18.41	500.00	100.0	H	169.00	-9
1539.88	---	39.37	54.00	14.63	500.00	200.0	V	356.00	-9
1899.50	47.77	---	68.20	20.43	500.00	100.0	H	0.00	-8
2538.25	50.43	---	68.20	17.77	500.00	100.0	H	0.00	-6
2813.88	---	38.98	54.00	15.02	500.00	100.0	H	0.00	-5
3331.88	51.00	---	68.20	17.20	500.00	200.0	H	227.00	-4
3977.63	---	40.87	54.00	13.13	500.00	100.0	V	166.00	-2
5401.25	---	45.76	54.00	8.24	500.00	100.0	V	15.00	3
5592.88	59.61	---	68.20	8.59	500.00	200.0	V	356.00	3
5903.50	63.90	---	68.20	4.30	500.00	200.0	V	197.00	4
7496.00	---	47.91	54.00	6.09	500.00	100.0	H	0.00	8

Remark: 1. Correction Factor = Antenna factor + Insertion loss (cable loss + amplifier gain)

2. Margin = Limit –MAX Peak/ Average

802.11ax (HE20) CH157

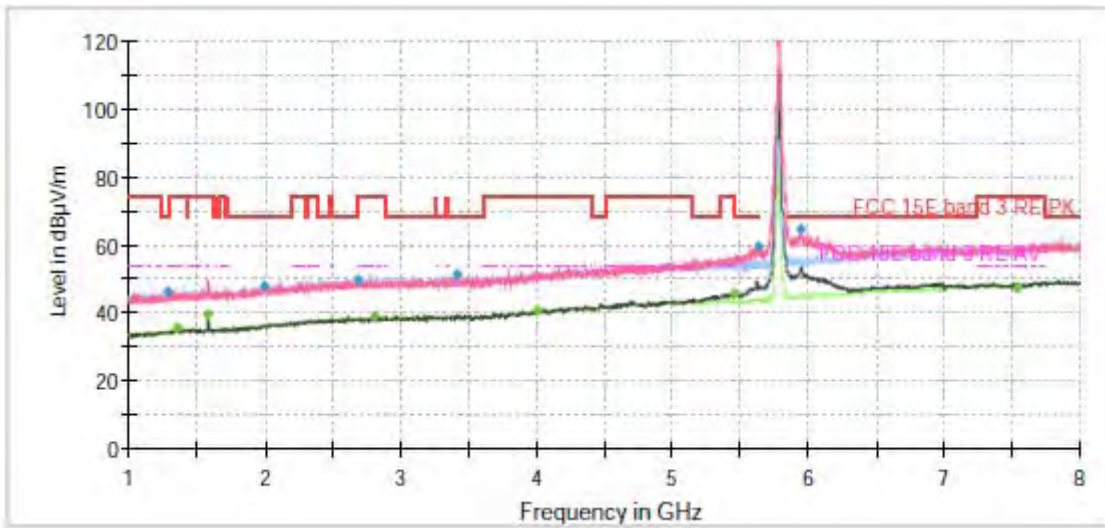

Note: The signal beyond the limit is carrier.
Radiates Emission from 1GHz to 8GHz

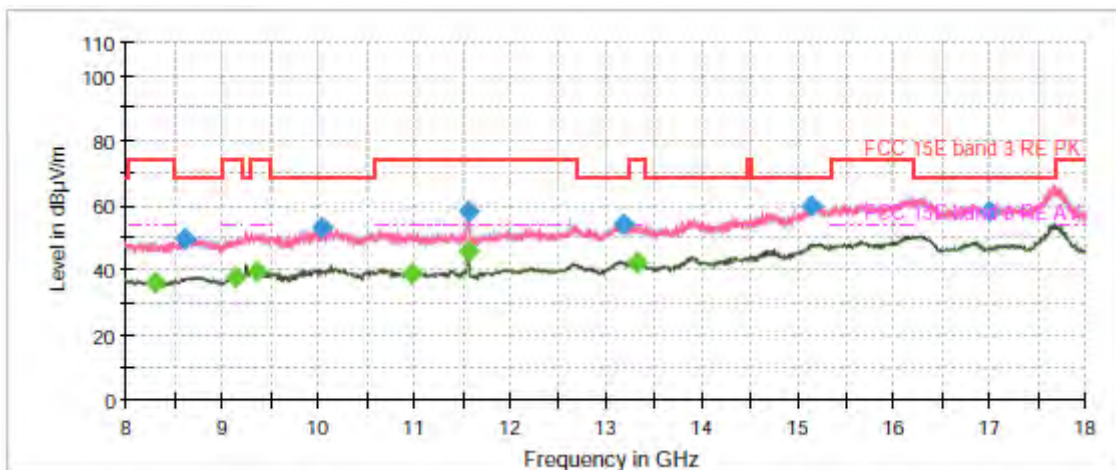

Radiates Emission from 8GHz to 18GHz

Frequency (MHz)	MaxPeak (dB μ V/m)	Average (dB μ V/m)	Limit (dB μ V/m)	Margin (dB)	Meas. Time (ms)	Height (cm)	Pol	Azimuth (deg)	Corr. (dB/m)
1279.13	46.34	---	68.20	21.86	500.00	200.0	H	36.00	-10
1358.75	---	35.68	54.00	18.32	500.00	100.0	H	332.00	-9
1580.13	---	39.81	54.00	14.19	500.00	200.0	V	353.00	-9
1989.63	48.00	---	68.20	20.20	500.00	100.0	V	7.00	-7
2689.63	49.89	---	68.20	18.31	500.00	200.0	H	2.00	-5
2799.00	---	39.22	54.00	14.78	500.00	200.0	H	0.00	-5
3407.13	51.10	---	68.20	17.10	500.00	100.0	V	1.00	-4
3996.88	---	40.64	54.00	13.36	500.00	100.0	V	10.00	-2
5457.25	---	45.76	54.00	8.24	500.00	200.0	V	357.00	3
5626.13	59.67	---	68.20	8.53	500.00	200.0	V	335.00	3
5944.63	64.74	---	68.20	3.46	500.00	200.0	V	181.00	4
7537.13	---	47.59	54.00	6.41	500.00	100.0	V	40.00	8

Remark: 1. Correction Factor = Antenna factor + Insertion loss (cable loss + amplifier gain)

2. Margin = Limit –MAX Peak/ Average

802.11ax (HE20) CH165

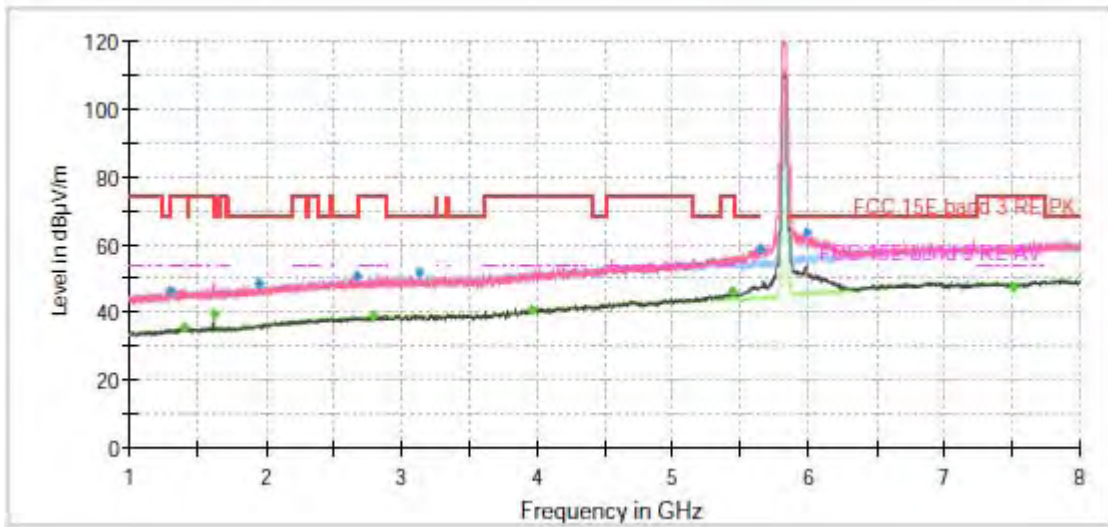

Note: The signal beyond the limit is carrier.
Radiates Emission from 1GHz to 8GHz

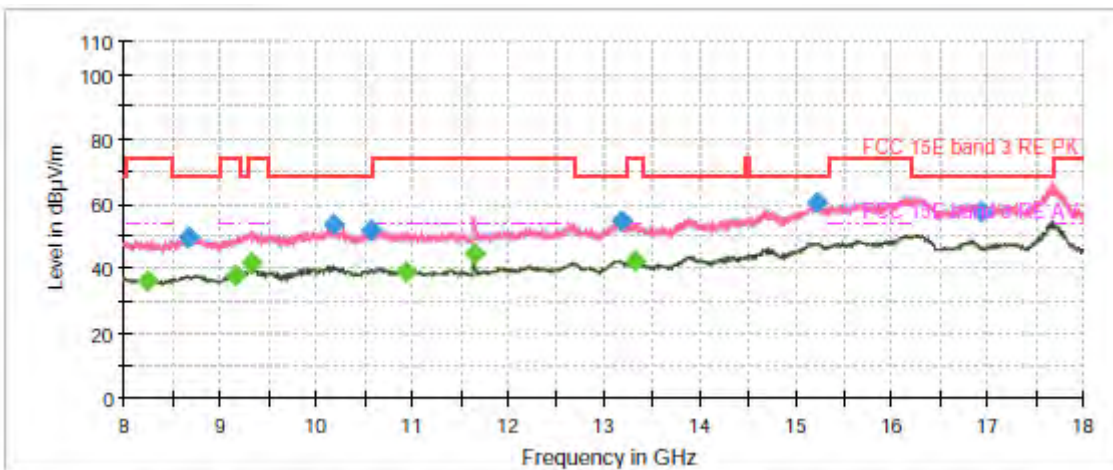

Radiates Emission from 8GHz to 18GHz

Frequency (MHz)	MaxPeak (dB μ V/m)	Average (dB μ V/m)	Limit (dB μ V/m)	Margin (dB)	Meas. Time (ms)	Height (cm)	Pol	Azimuth (deg)	Corr. (dB/m)
1294.00	46.19	---	68.20	22.01	500.00	200.0	H	22.00	-9
1402.50	---	35.75	54.00	18.25	500.00	100.0	H	325.00	-9
1620.38	---	39.62	54.00	14.38	500.00	200.0	V	352.00	-9
1953.75	48.34	---	68.20	19.86	500.00	100.0	V	1.00	-8
2671.25	50.53	---	68.20	17.67	500.00	100.0	H	39.00	-6
2795.50	---	39.05	54.00	14.95	500.00	100.0	H	356.00	-5
3128.00	51.67	---	68.20	16.53	500.00	200.0	H	22.00	-5
3967.13	---	41.02	54.00	12.98	500.00	100.0	H	345.00	-2
5445.00	---	46.14	54.00	7.86	500.00	100.0	V	1.00	3
5641.88	58.69	---	68.20	9.51	500.00	200.0	V	354.00	3
5985.75	63.62	---	68.20	4.58	500.00	200.0	V	324.00	4
7512.63	---	47.56	54.00	6.44	500.00	100.0	V	49.00	8

Remark: 1. Correction Factor = Antenna factor + Insertion loss (cable loss + amplifier gain)

2. Margin = Limit –MAX Peak/ Average

802.11ax (HE40) CH38

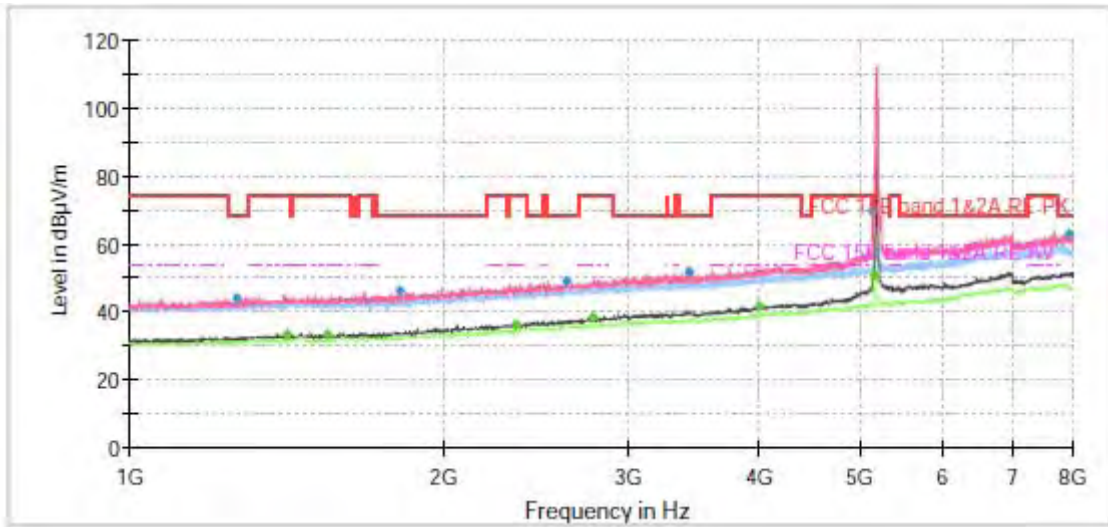

Note: The signal beyond the limit is carrier.
Radiates Emission from 1GHz to 8GHz

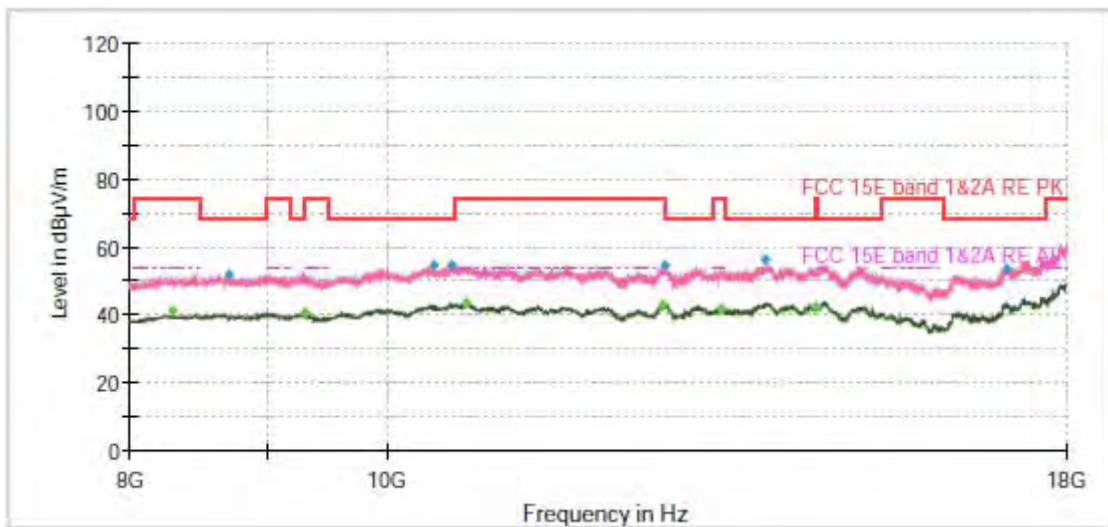

Radiates Emission from 8GHz to 18GHz

Frequency (MHz)	MaxPeak (dB μ V/m)	Average (dB μ V/m)	Limit (dB μ V/m)	Margin (dB)	Meas. Time (ms)	Height (cm)	Pol	Azimuth (deg)	Corr. (dB/m)
1265.13	44.21	---	68.20	23.99	500.00	200.0	V	353.00	-2
1413.00	---	33.29	54.00	20.71	500.00	200.0	V	357.00	-1
1546.88	---	33.65	54.00	20.35	500.00	100.0	V	182.00	-1
1813.75	46.08	---	68.20	22.12	500.00	200.0	V	202.00	0
2342.25	---	36.03	54.00	17.97	500.00	200.0	V	264.00	2
2617.88	49.05	---	68.20	19.15	500.00	100.0	V	108.00	4
2771.00	---	38.29	54.00	15.71	500.00	100.0	V	243.00	4
3424.63	51.65	---	68.20	16.55	500.00	100.0	V	3.00	5
3998.63	---	41.71	54.00	12.29	500.00	100.0	V	0.00	6
5137.88	70.03	---	74.00	3.97	500.00	200.0	V	189.00	10
5149.25	---	51.04	54.00	2.96	500.00	100.0	V	5.00	10
7926.50	62.83	---	68.20	5.37	500.00	200.0	V	284.00	17

Remark: 1. Correction Factor = Antenna factor + Insertion loss (cable loss + amplifier gain)

2. Margin = Limit –MAX Peak/ Average

802.11ax (HE40) CH46

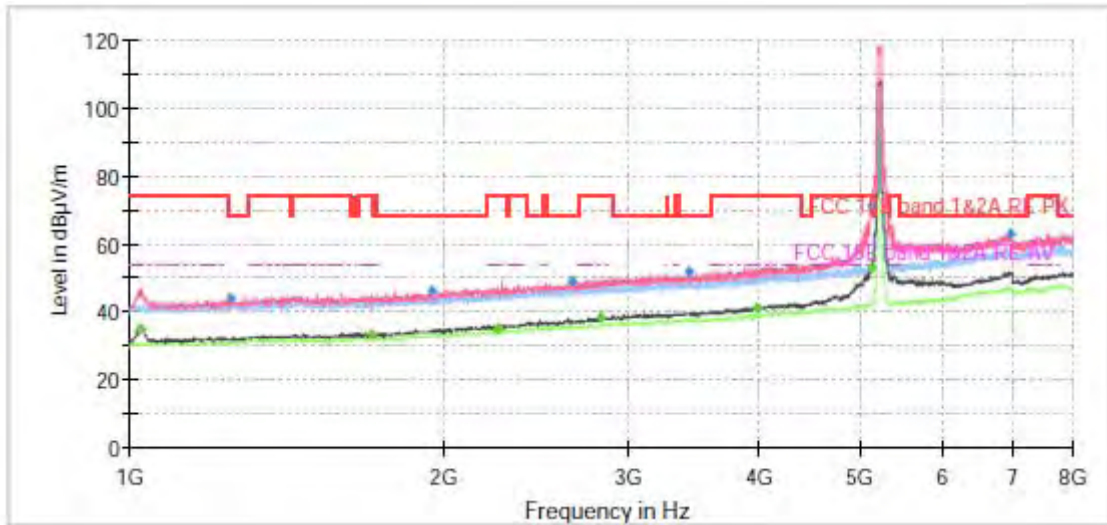

Note: The signal beyond the limit is carrier.
Radiates Emission from 1GHz to 8GHz

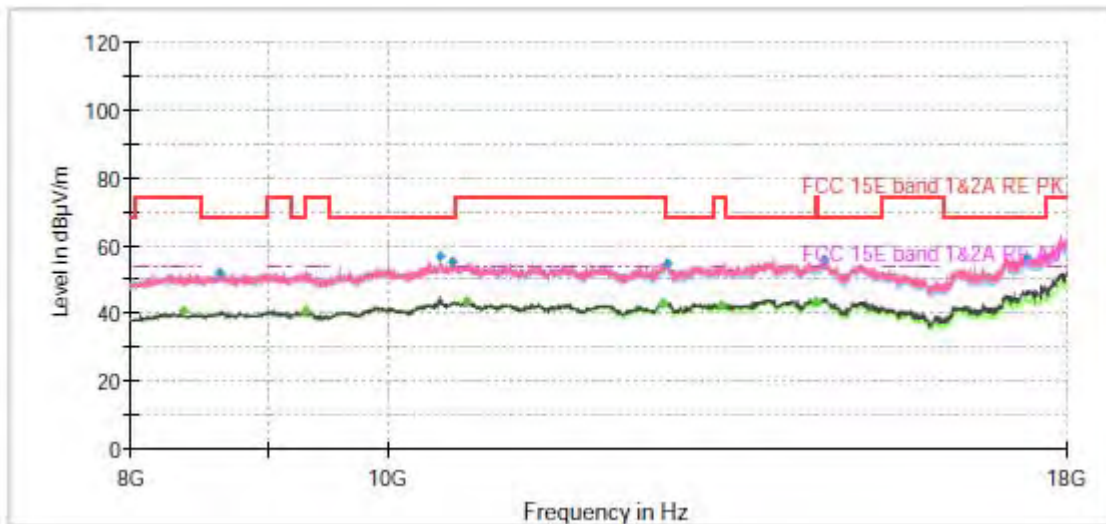

Radiates Emission from 8GHz to 18GHz

Frequency (MHz)	MaxPeak (dB μ V/m)	Average (dB μ V/m)	Limit (dB μ V/m)	Margin (dB)	Meas. Time (ms)	Height (cm)	Pol	Azimuth (deg)	Corr. (dB/m)
1023.63	---	35.35	54.00	18.65	500.00	200.0	V	205.00	-3
1250.25	44.04	---	68.20	24.16	500.00	200.0	V	354.00	-2
1706.13	---	33.73	54.00	20.27	500.00	200.0	V	219.00	-1
1946.75	46.34	---	68.20	21.86	500.00	200.0	V	245.00	1
2249.50	---	35.44	54.00	18.56	500.00	100.0	V	2.00	2
2657.25	49.38	---	68.20	18.82	500.00	200.0	V	0.00	4
2822.63	---	38.24	54.00	15.76	500.00	200.0	V	245.00	4
3423.75	51.85	---	68.20	16.35	500.00	200.0	V	192.00	5
3992.50	---	41.56	54.00	12.44	500.00	200.0	V	0.00	6
5127.38	71.28	---	74.00	2.72	500.00	200.0	V	171.00	10
5127.38	---	53.21	54.00	0.79	500.00	200.0	V	171.00	10
6961.38	62.98	---	68.20	5.22	500.00	100.0	V	30.00	14

Remark: 1. Correction Factor = Antenna factor + Insertion loss (cable loss + amplifier gain)

2. Margin = Limit –MAX Peak/ Average

802.11ax (HE40) CH54

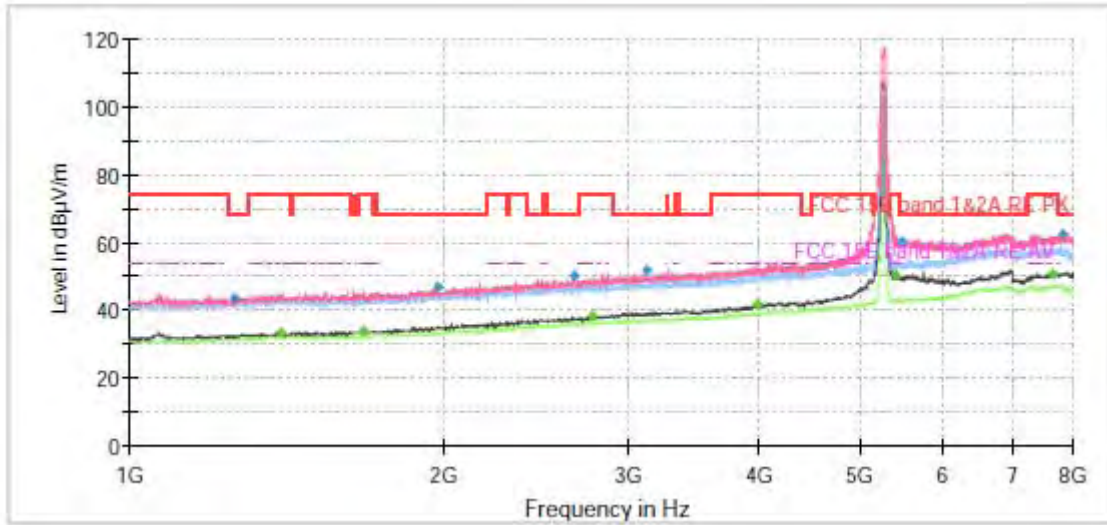

Note: The signal beyond the limit is carrier.
Radiates Emission from 1GHz to 8GHz

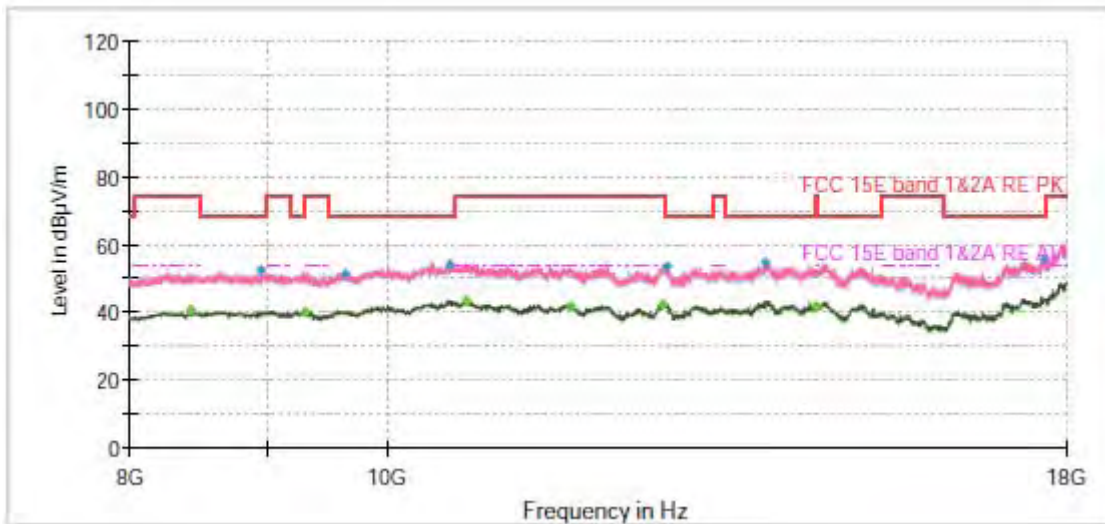

Radiates Emission from 8GHz to 18GHz

Frequency (MHz)	MaxPeak (dB μ V/m)	Average (dB μ V/m)	Limit (dB μ V/m)	Margin (dB)	Meas. Time (ms)	Height (cm)	Pol	Azimuth (deg)	Corr. (dB/m)
1258.13	43.63	---	68.20	24.57	500.00	200.0	V	0.00	-2
1393.75	---	33.50	54.00	20.50	500.00	100.0	V	349.00	-1
1674.63	---	34.04	54.00	19.96	500.00	100.0	V	259.00	-1
1973.00	47.04	---	68.20	21.16	500.00	100.0	V	166.00	1
2667.75	50.15	---	68.20	18.05	500.00	100.0	V	0.00	4
2769.25	---	38.33	54.00	15.67	500.00	100.0	V	186.00	4
3120.13	51.89	---	68.20	16.31	500.00	200.0	V	7.00	5
3993.38	---	41.84	54.00	12.16	500.00	100.0	V	112.00	6
5403.88	---	50.13	54.00	3.87	500.00	200.0	V	166.00	11
5487.00	60.35	---	68.20	7.85	500.00	200.0	V	140.00	11
7664.00	---	50.82	54.00	3.18	500.00	100.0	V	352.00	17
7819.75	62.58	---	68.20	5.62	500.00	100.0	V	0.00	17

Remark: 1. Correction Factor = Antenna factor + Insertion loss (cable loss + amplifier gain)

2. Margin = Limit –MAX Peak/ Average

802.11ax (HE40) CH62

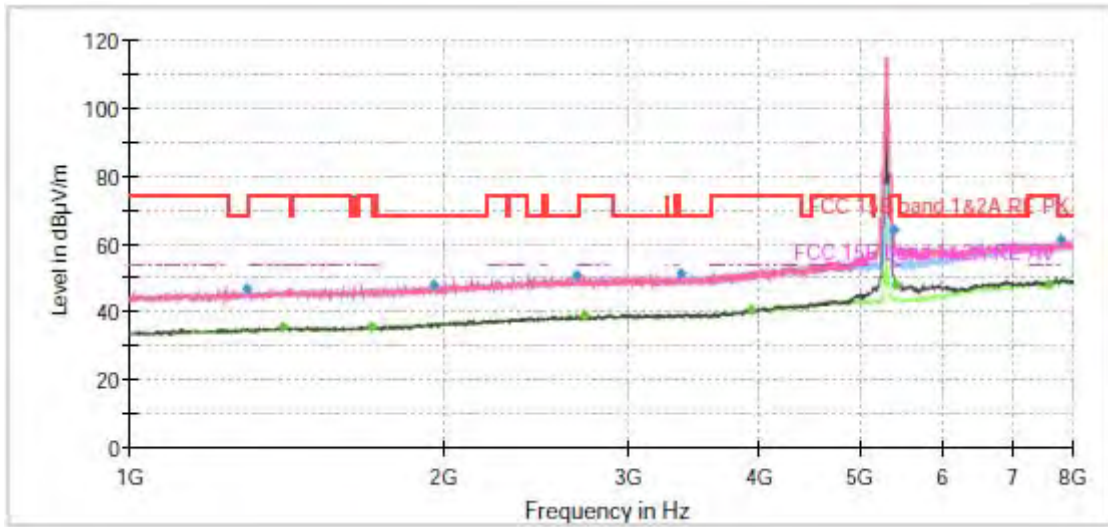

Note: The signal beyond the limit is carrier.
Radiates Emission from 1GHz to 8GHz

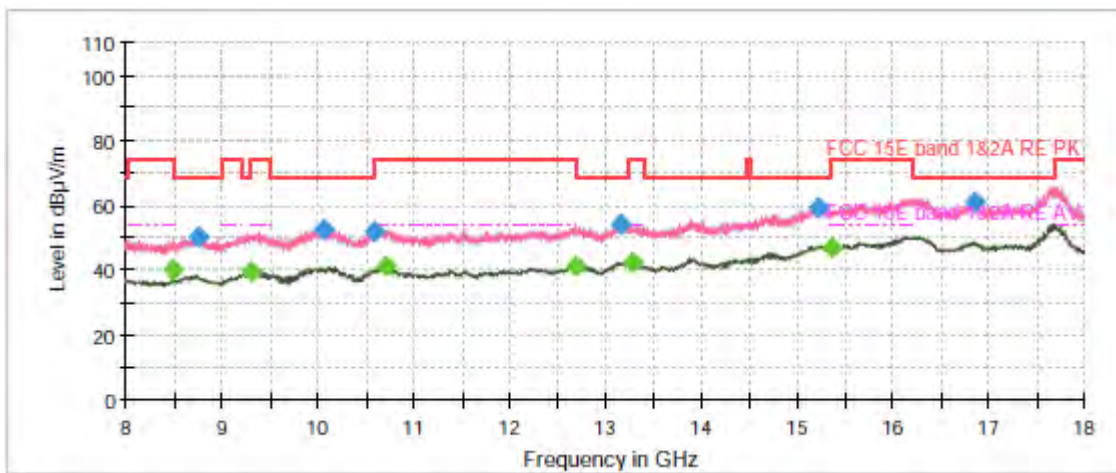

Radiates Emission from 8GHz to 18GHz

Frequency (MHz)	MaxPeak (dB μ V/m)	Average (dB μ V/m)	Limit (dB μ V/m)	Margin (dB)	Meas. Time (ms)	Height (cm)	Pol	Azimuth (deg)	Corr. (dB/m)
1292.25	47.00	---	68.20	21.20	500.00	200.0	H	28.00	-9
1401.63	---	35.90	54.00	18.10	500.00	100.0	H	216.00	-9
1699.13	---	35.82	54.00	18.18	500.00	100.0	V	312.00	-8
1954.63	48.09	---	68.20	20.11	500.00	200.0	H	35.00	-8
2672.13	50.75	---	68.20	17.45	500.00	200.0	V	97.00	-6
2729.00	---	38.89	54.00	15.11	500.00	200.0	H	122.00	-5
3362.50	51.31	---	68.20	16.89	500.00	200.0	V	178.00	-4
3936.50	---	40.99	54.00	13.01	500.00	200.0	V	0.00	-2
5397.75	64.37	---	74.00	9.63	500.00	200.0	V	356.00	3
5424.00	---	47.80	54.00	6.20	500.00	200.0	V	0.00	3
7600.13	---	47.74	54.00	6.26	500.00	200.0	H	12.00	8
7804.88	61.23	---	68.20	6.97	500.00	100.0	H	276.00	9

Remark: 1. Correction Factor = Antenna factor + Insertion loss (cable loss + amplifier gain)

2. Margin = Limit –MAX Peak/ Average

802.11ax (HE40) CH102

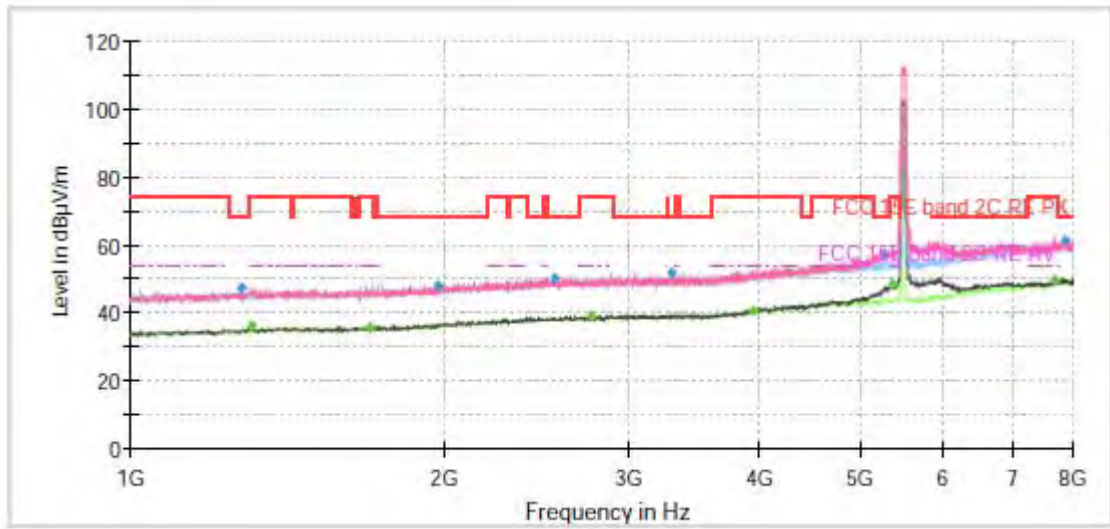

Note: The signal beyond the limit is carrier.
Radiates Emission from 1GHz to 8GHz

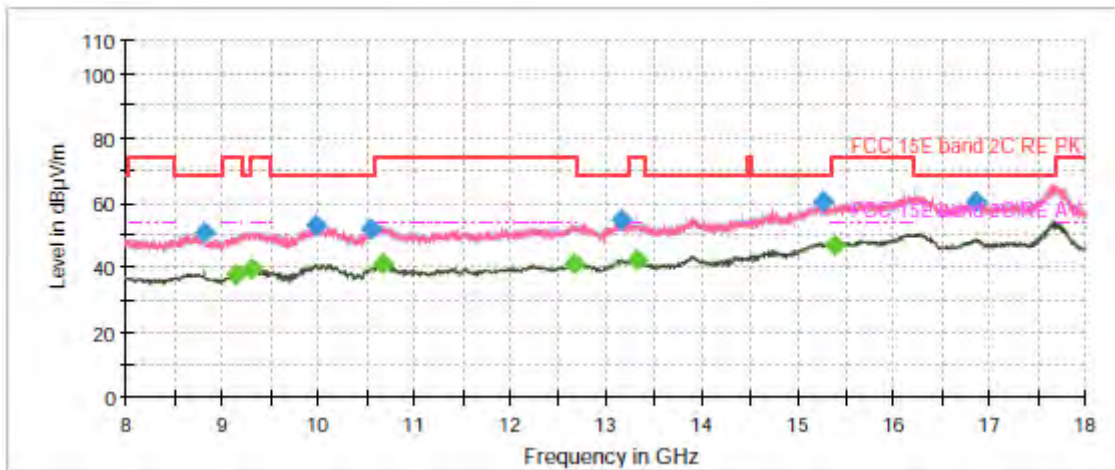

Radiates Emission from 8GHz to 18GHz

Frequency (MHz)	MaxPeak (dB μ V/m)	Average (dB μ V/m)	Limit (dB μ V/m)	Margin (dB)	Meas. Time (ms)	Height (cm)	Pol	Azimuth (deg)	Corr. (dB/m)
1277.38	47.47	---	68.20	20.73	500.00	200.0	H	97.00	-10
1304.50	---	36.25	54.00	17.75	500.00	200.0	V	358.00	-9
1694.75	---	35.84	54.00	18.16	500.00	100.0	V	30.00	-8
1970.38	47.96	---	68.20	20.24	500.00	200.0	H	5.00	-8
2549.63	50.49	---	68.20	17.71	500.00	200.0	V	342.00	-6
2755.25	---	39.30	54.00	14.70	500.00	200.0	H	9.00	-5
3296.00	51.87	---	68.20	16.33	500.00	100.0	V	97.00	-4
3945.25	---	40.93	54.00	13.07	500.00	200.0	V	350.00	-2
5268.25	57.74	---	68.20	10.46	500.00	100.0	V	178.00	3
5379.38	---	48.29	54.00	5.71	500.00	200.0	V	48.00	3
7700.75	---	49.52	54.00	4.48	500.00	200.0	V	199.00	9
7874.00	61.27	---	68.20	6.93	500.00	200.0	V	309.00	9

Remark: 1. Correction Factor = Antenna factor + Insertion loss (cable loss + amplifier gain)

2. Margin = Limit - MAX Peak/ Average

802.11ax (HE40) CH118

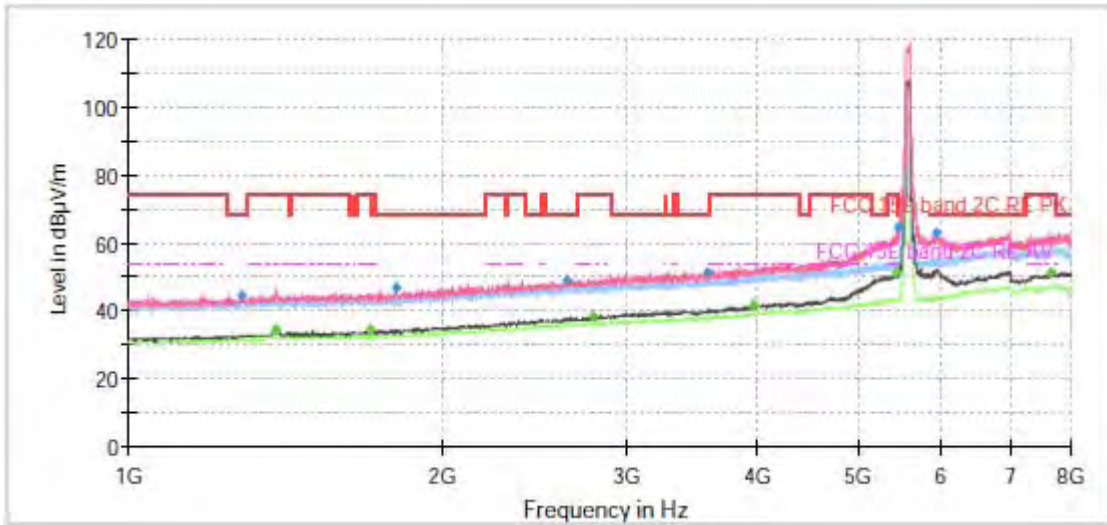

Note: The signal beyond the limit is carrier.
Radiates Emission from 1GHz to 8GHz

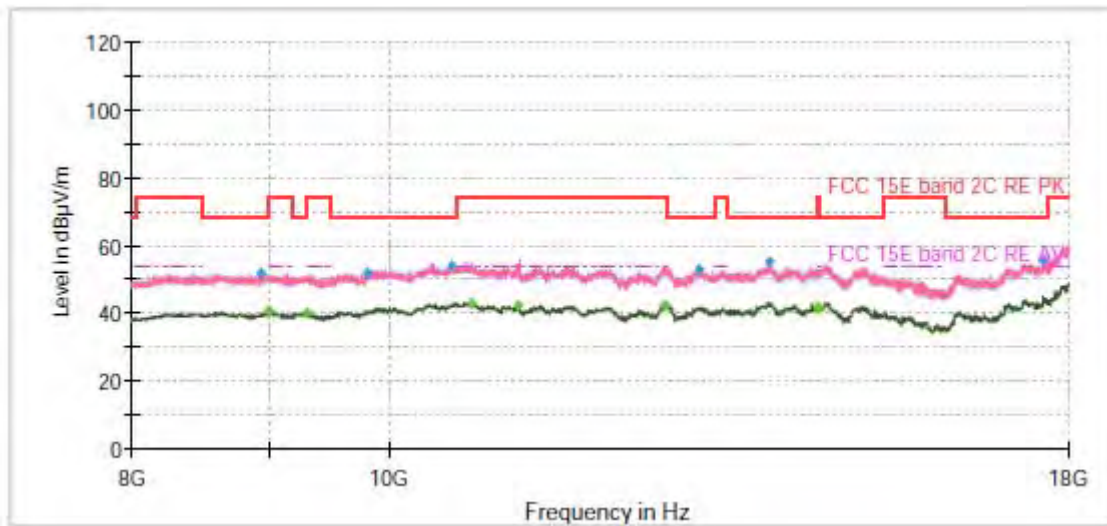

Radiates Emission from 8GHz to 18GHz

Frequency (MHz)	MaxPeak (dB μ V/m)	Average (dB μ V/m)	Limit (dB μ V/m)	Margin (dB)	Meas. Time (ms)	Height (cm)	Pol	Azimuth (deg)	Corr. (dB/m)
1284.38	44.40	---	68.20	23.80	500.00	200.0	V	146.00	-2
1385.00	---	34.43	54.00	19.57	500.00	200.0	V	159.00	-1
1702.63	---	34.44	54.00	19.56	500.00	100.0	V	243.00	-1
1806.75	46.76	---	68.20	21.44	500.00	100.0	V	297.00	0
2627.50	49.34	---	68.20	18.86	500.00	100.0	V	115.00	4
2789.38	---	38.33	54.00	15.67	500.00	200.0	V	312.00	4
3579.50	51.60	---	68.20	16.60	500.00	100.0	V	359.00	5
3974.13	---	41.63	54.00	12.37	500.00	100.0	V	48.00	6
5433.63	---	51.29	54.00	2.71	500.00	200.0	V	105.00	12
5469.50	64.48	---	68.20	3.72	500.00	100.0	V	357.00	11
5955.13	62.87	---	68.20	5.33	500.00	200.0	V	14.00	11
7664.00	---	51.14	54.00	2.86	500.00	100.0	V	318.00	17

Remark: 1. Correction Factor = Antenna factor + Insertion loss (cable loss + amplifier gain)

2. Margin = Limit –MAX Peak/ Average

802.11ax (HE40) CH134

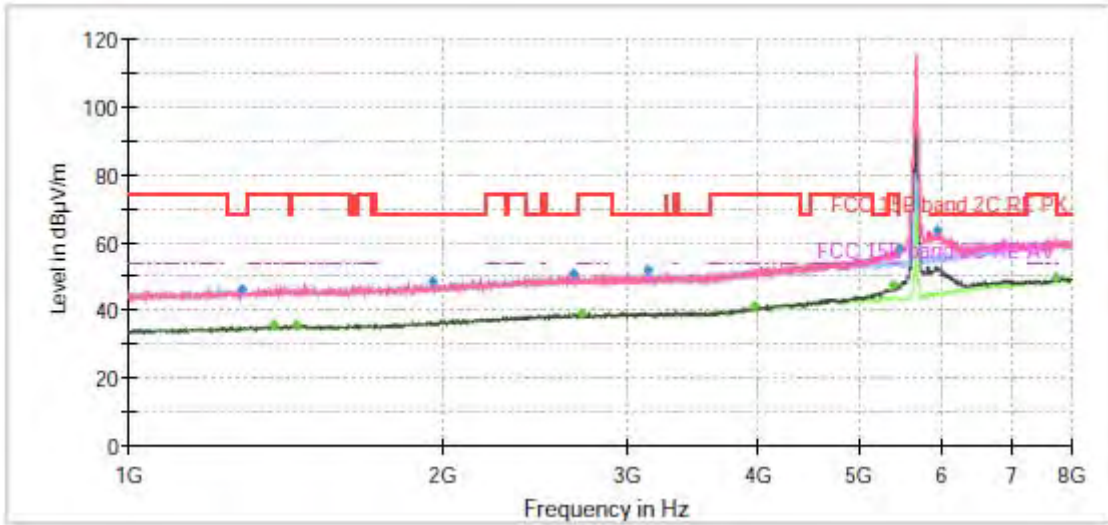

Note: The signal beyond the limit is carrier.
Radiates Emission from 1GHz to 8GHz

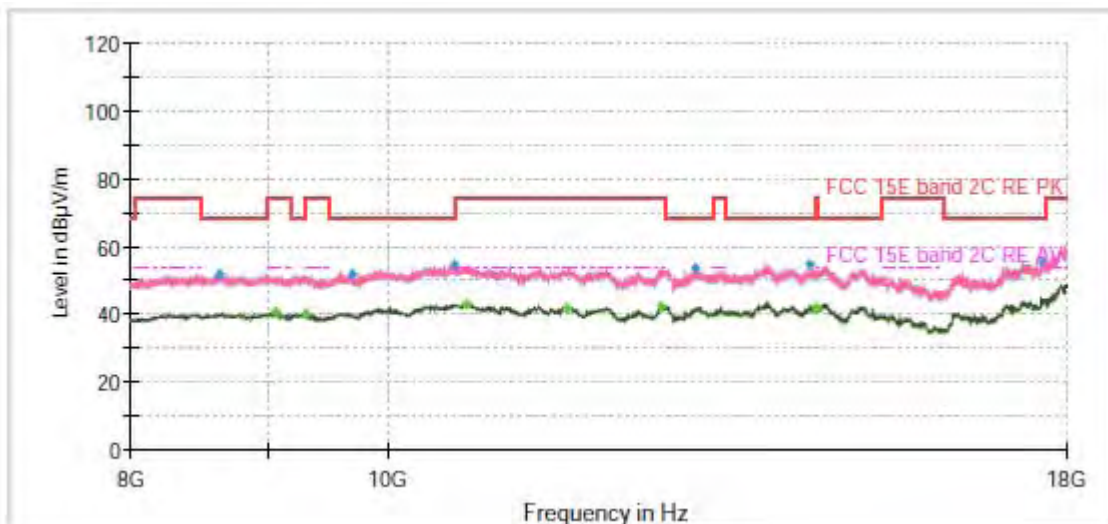

Radiates Emission from 8GHz to 18GHz

Frequency (MHz)	MaxPeak (dB μ V/m)	Average (dB μ V/m)	Limit (dB μ V/m)	Margin (dB)	Meas. Time (ms)	Height (cm)	Pol	Azimuth (deg)	Corr. (dB/m)
1284.38	46.22	---	68.20	21.98	500.00	100.0	H	355.00	-10
1378.00	---	35.83	54.00	18.17	500.00	100.0	H	180.00	-9
1446.25	---	35.84	54.00	18.16	500.00	100.0	H	259.00	-9
1956.38	48.50	---	68.20	19.70	500.00	100.0	H	279.00	-8
2669.50	50.69	---	68.20	17.51	500.00	100.0	V	9.00	-6
2712.38	---	39.11	54.00	14.89	500.00	100.0	V	116.00	-6
3143.75	51.93	---	68.20	16.27	500.00	100.0	V	49.00	-5
3966.25	---	41.15	54.00	12.85	500.00	100.0	H	326.00	-2
5396.00	---	47.32	54.00	6.68	500.00	200.0	V	118.00	3
5461.63	58.20	---	68.20	10.00	500.00	200.0	V	341.00	3
5935.00	63.40	---	68.20	4.80	500.00	200.0	V	199.00	4
7734.00	---	49.42	54.00	4.58	500.00	100.0	V	116.00	9

Remark: 1. Correction Factor = Antenna factor + Insertion loss (cable loss + amplifier gain)

2. Margin = Limit –MAX Peak/ Average

802.11ax (HE40) CH142

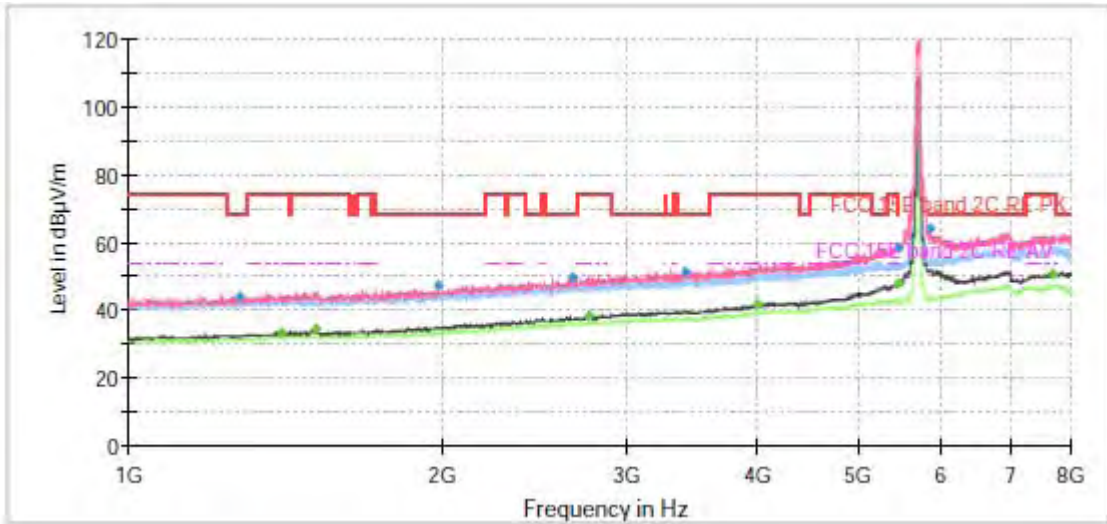

Note: The signal beyond the limit is carrier.
Radiates Emission from 1GHz to 8GHz

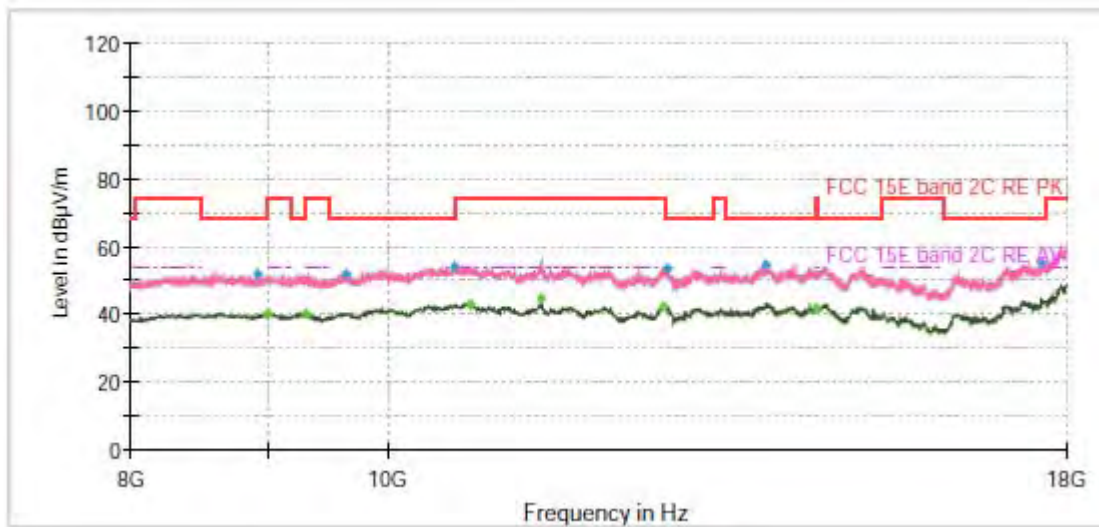

Radiates Emission from 8GHz to 18GHz

Frequency (MHz)	MaxPeak (dB μ V/m)	Average (dB μ V/m)	Limit (dB μ V/m)	Margin (dB)	Meas. Time (ms)	Height (cm)	Pol	Azimuth (deg)	Corr. (dB/m)
1274.75	44.28	---	68.20	23.92	500.00	100.0	V	231.00	-2
1403.38	---	33.43	54.00	20.57	500.00	100.0	V	353.00	-1
1508.38	---	34.74	54.00	19.26	500.00	200.0	V	190.00	-1
1981.75	47.22	---	68.20	20.98	500.00	200.0	V	203.00	1
2666.88	49.47	---	68.20	18.73	500.00	200.0	V	263.00	4
2761.38	---	38.57	54.00	15.43	500.00	200.0	V	352.00	4
3415.00	51.52	---	68.20	16.68	500.00	100.0	V	178.00	5
3997.75	---	41.71	54.00	12.29	500.00	200.0	V	352.00	6
5455.50	---	48.12	54.00	5.88	500.00	100.0	V	22.00	11
5465.13	58.53	---	68.20	9.67	500.00	100.0	V	4.00	11
5858.88	63.91	---	68.20	4.29	500.00	200.0	V	170.00	11
7670.13	---	50.90	54.00	3.10	500.00	100.0	V	0.00	17

Remark: 1. Correction Factor = Antenna factor + Insertion loss (cable loss + amplifier gain)

2. Margin = Limit –MAX Peak/ Average

802.11ax (HE40) CH151

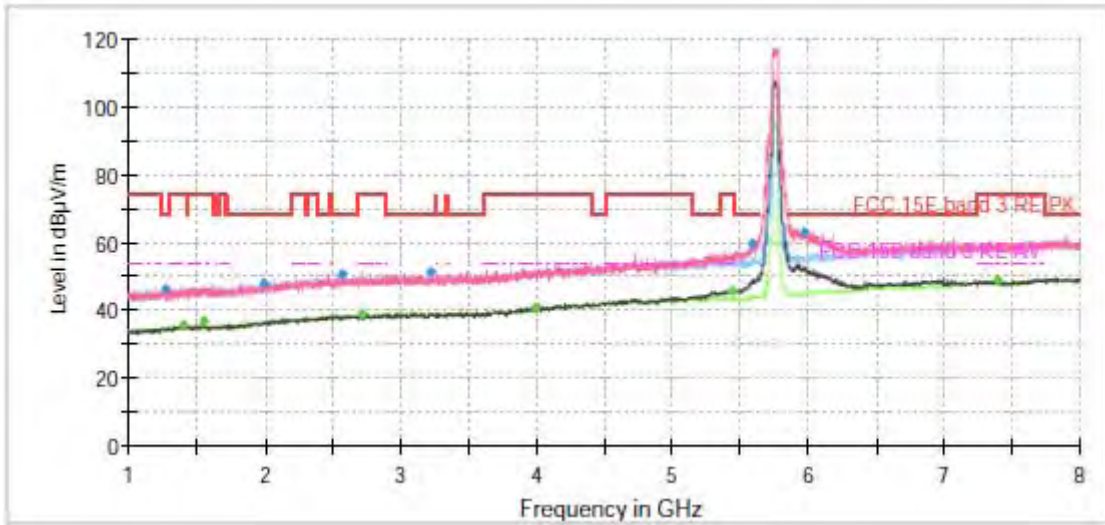

Note: The signal beyond the limit is carrier.
Radiates Emission from 1GHz to 8GHz

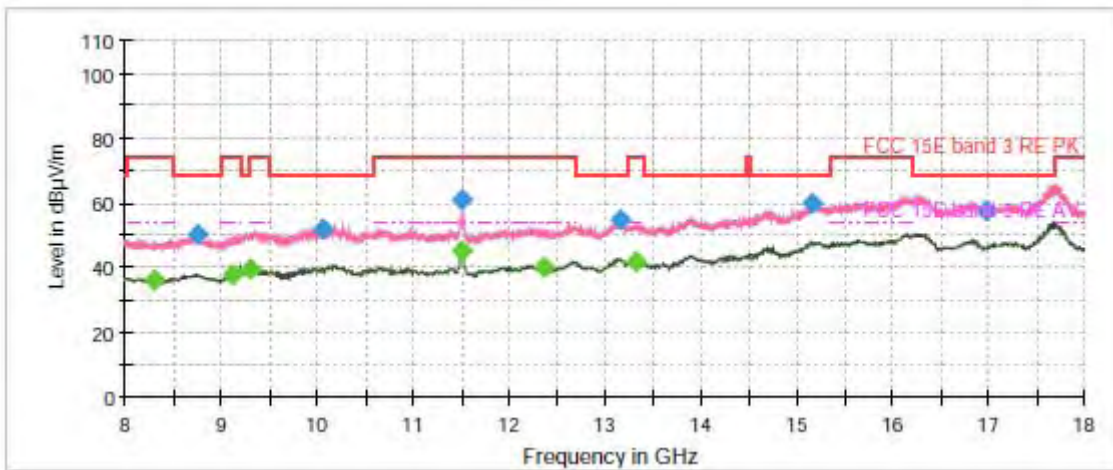

Radiates Emission from 8GHz to 18GHz

Frequency (MHz)	MaxPeak (dB μ V/m)	Average (dB μ V/m)	Limit (dB μ V/m)	Margin (dB)	Meas. Time (ms)	Height (cm)	Pol	Azimuth (deg)	Corr. (dB/m)
1270.38	46.49	---	68.20	21.71	500.00	200.0	V	223.00	-10
1404.25	---	35.56	54.00	18.44	500.00	100.0	V	5.00	-9
1553.00	---	36.79	54.00	17.21	500.00	200.0	V	23.00	-9
1998.38	48.23	---	68.20	19.97	500.00	200.0	H	256.00	-7
2569.75	50.73	---	68.20	17.47	500.00	100.0	H	325.00	-6
2723.75	---	39.04	54.00	14.96	500.00	100.0	H	247.00	-6
3220.75	51.55	---	68.20	16.65	500.00	100.0	H	109.00	-4
3990.75	---	40.92	54.00	13.08	500.00	100.0	V	50.00	-2
5439.75	---	46.04	54.00	7.96	500.00	100.0	V	223.00	3
5587.63	59.52	---	68.20	8.68	500.00	200.0	V	0.00	3
5973.50	63.16	---	68.20	5.04	500.00	200.0	V	0.00	4
7393.63	---	49.01	54.00	4.99	500.00	100.0	V	59.00	8

Remark: 1. Correction Factor = Antenna factor + Insertion loss (cable loss + amplifier gain)

2. Margin = Limit –MAX Peak/ Average

802.11ax (HE40) CH159

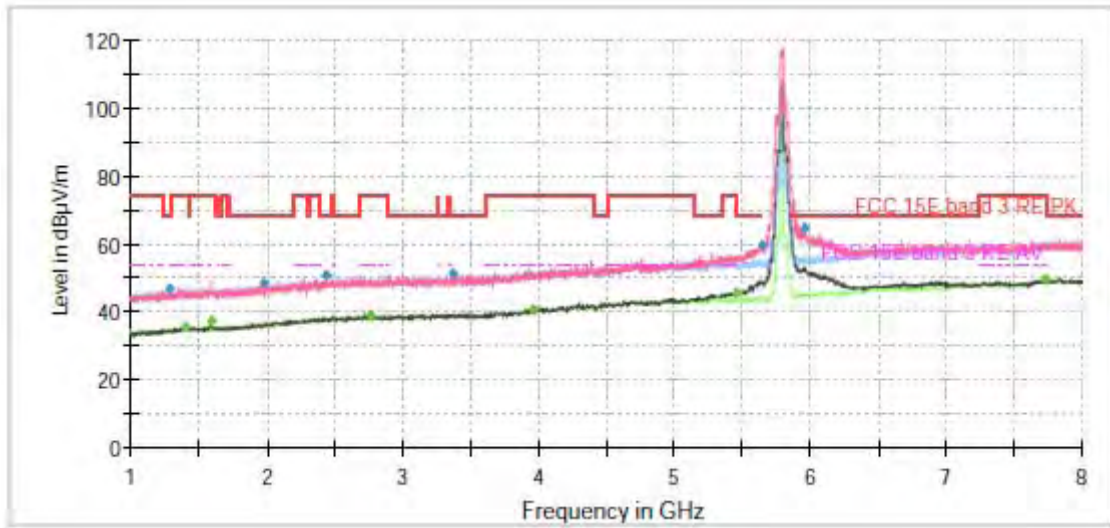

Note: The signal beyond the limit is carrier.
Radiates Emission from 1GHz to 8GHz

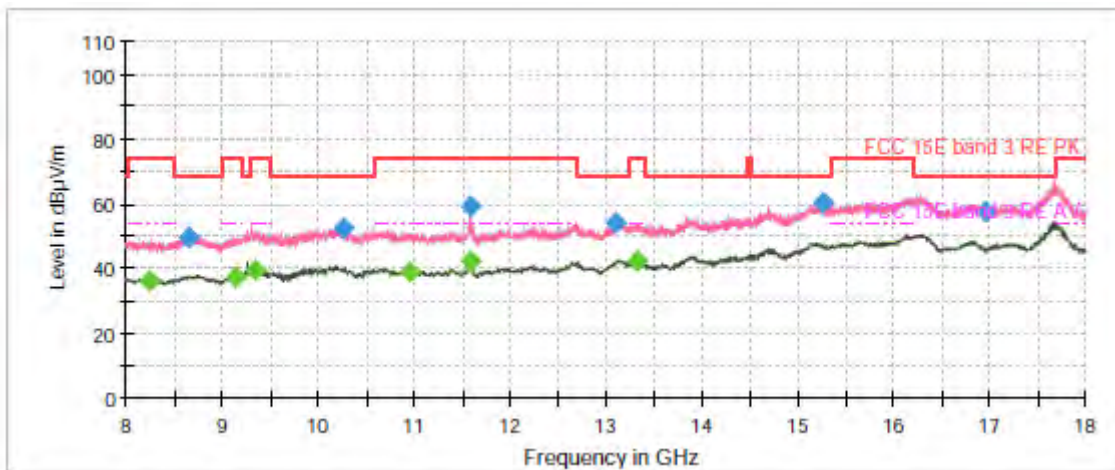

Radiates Emission from 8GHz to 18GHz

Frequency (MHz)	MaxPeak (dB μ V/m)	Average (dB μ V/m)	Limit (dB μ V/m)	Margin (dB)	Meas. Time (ms)	Height (cm)	Pol	Azimuth (deg)	Corr. (dB/m)
1282.63	46.85	---	68.20	21.35	500.00	100.0	V	24.00	-10
1394.63	---	35.62	54.00	18.38	500.00	100.0	H	219.00	-9
1589.75	---	37.25	54.00	16.75	500.00	200.0	V	184.00	-9
1973.88	48.38	---	68.20	19.82	500.00	200.0	H	129.00	-8
2436.75	50.61	---	68.20	17.59	500.00	200.0	V	356.00	-6
2757.00	---	38.95	54.00	15.05	500.00	200.0	H	0.00	-5
3365.13	51.57	---	68.20	16.63	500.00	100.0	V	13.00	-4
3955.75	---	40.96	54.00	13.04	500.00	100.0	V	259.00	-2
5448.50	---	45.71	54.00	8.29	500.00	100.0	V	18.00	3
5646.25	59.73	---	68.20	8.47	500.00	200.0	V	23.00	3
5963.00	64.59	---	68.20	3.61	500.00	200.0	V	0.00	4
7737.50	---	49.88	54.00	4.12	500.00	200.0	H	4.00	9

Remark: 1. Correction Factor = Antenna factor + Insertion loss (cable loss + amplifier gain)

2. Margin = Limit –MAX Peak/ Average

802.11ax (HE80) CH42

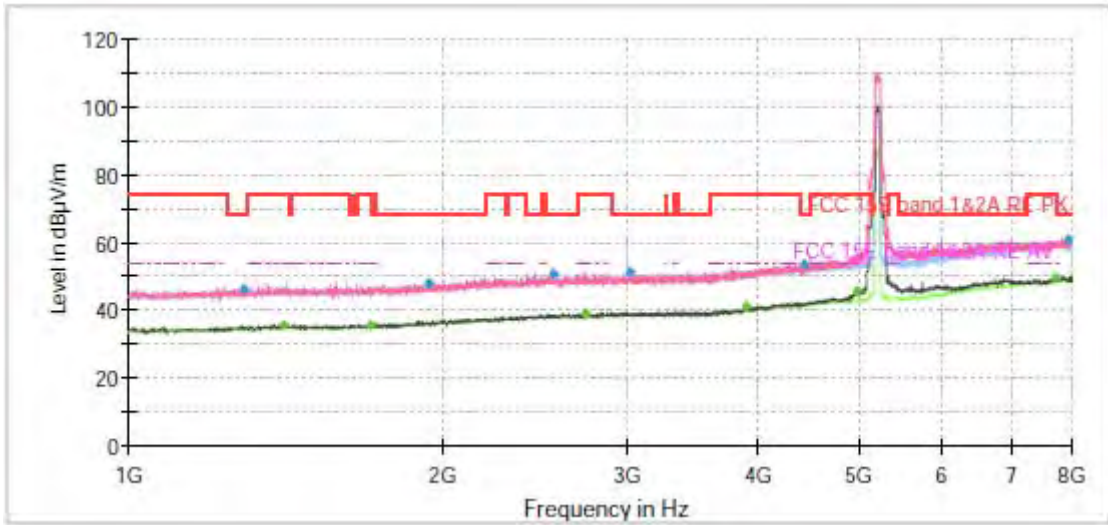

Note: The signal beyond the limit is carrier.
Radiates Emission from 1GHz to 8GHz

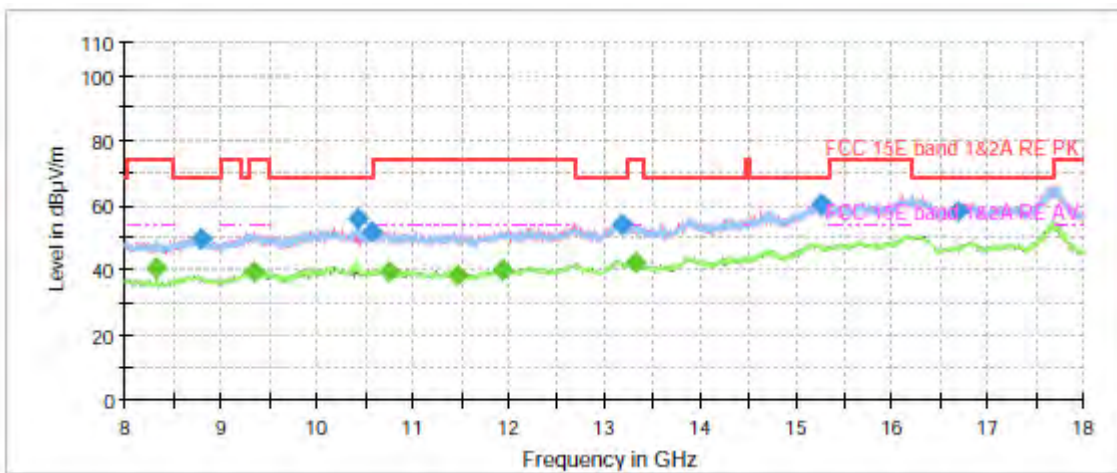

Radiates Emission from 8GHz to 18GHz

Frequency (MHz)	MaxPeak (dB μ V/m)	Average (dB μ V/m)	Limit (dB μ V/m)	Margin (dB)	Meas. Time (ms)	Height (cm)	Pol	Azimuth (deg)	Corr. (dB/m)
1285.25	46.60	---	68.20	21.60	500.00	100.0	H	355.00	-10
1409.50	---	35.82	54.00	18.18	500.00	200.0	V	327.00	-9
1701.75	---	35.80	54.00	18.20	500.00	200.0	V	83.00	-8
1938.00	48.08	---	68.20	20.12	500.00	100.0	V	263.00	-8
2544.38	50.60	---	68.20	17.60	500.00	100.0	H	0.00	-6
2730.75	---	39.19	54.00	14.81	500.00	100.0	V	1.00	-5
3013.38	51.46	---	68.20	16.74	500.00	200.0	V	252.00	-5
3898.88	---	41.14	54.00	12.86	500.00	200.0	V	327.00	-2
4445.75	53.48	---	68.20	14.72	500.00	100.0	V	270.00	-1
4980.38	---	45.61	54.00	8.39	500.00	200.0	V	124.00	2
7733.13	---	49.62	54.00	4.38	500.00	100.0	H	345.00	9
7928.25	61.05	---	68.20	7.15	500.00	100.0	V	121.00	9

Remark: 1. Correction Factor = Antenna factor + Insertion loss (cable loss + amplifier gain)

2. Margin = Limit - MAX Peak/ Average

802.11ax (HE80) CH58

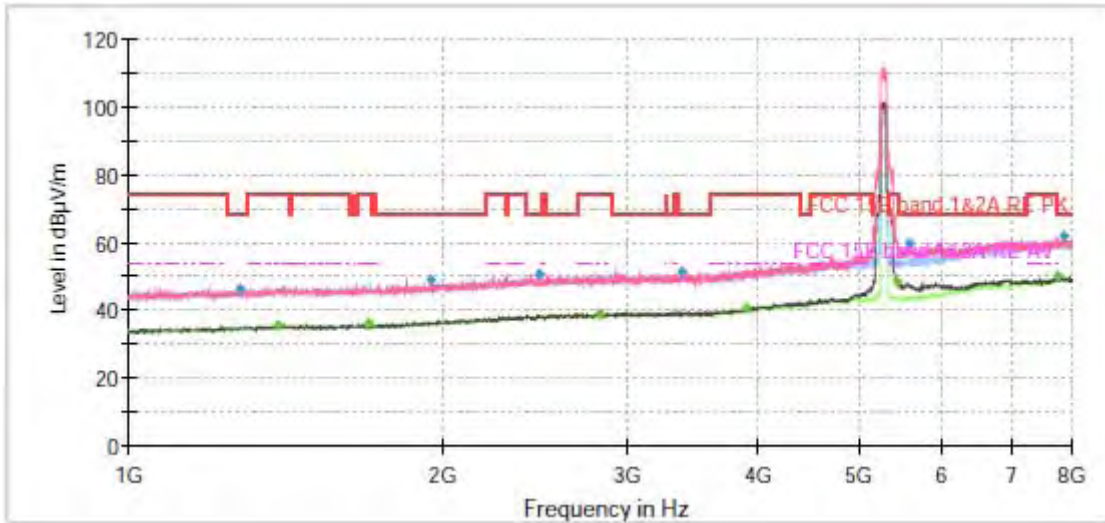

Note: The signal beyond the limit is carrier.
Radiates Emission from 1GHz to 8GHz

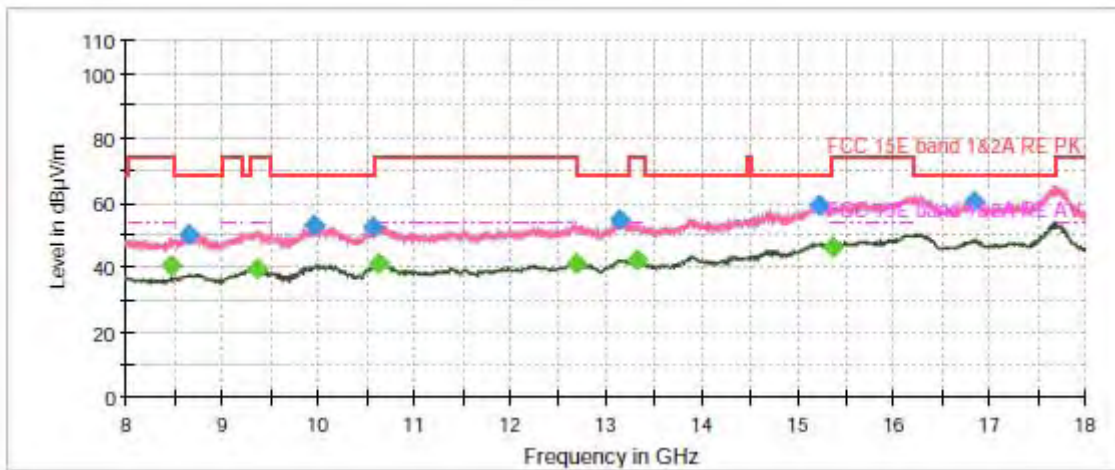

Radiates Emission from 8GHz to 18GHz

Frequency (MHz)	MaxPeak (dB μ V/m)	Average (dB μ V/m)	Limit (dB μ V/m)	Margin (dB)	Meas. Time (ms)	Height (cm)	Pol	Azimuth (deg)	Corr. (dB/m)
1278.25	46.50	---	68.20	21.70	500.00	100.0	V	173.00	-10
1391.13	---	35.56	54.00	18.44	500.00	100.0	H	170.00	-9
1698.25	---	36.03	54.00	17.97	500.00	200.0	H	214.00	-8
1941.50	48.94	---	68.20	19.26	500.00	100.0	H	47.00	-8
2475.25	50.74	---	68.20	17.46	500.00	200.0	V	106.00	-6
2820.00	---	39.10	54.00	14.90	500.00	100.0	H	210.00	-5
3385.25	51.34	---	68.20	16.86	500.00	100.0	H	263.00	-4
3904.13	---	40.95	54.00	13.05	500.00	100.0	V	125.00	-2
5448.50	---	48.34	54.00	5.66	500.00	200.0	V	358.00	3
5585.00	59.51	---	68.20	8.69	500.00	200.0	V	355.00	3
7741.88	---	50.02	54.00	3.98	500.00	200.0	H	11.00	9
7843.38	61.86	---	68.20	6.34	500.00	100.0	H	0.00	9

Remark: 1. Correction Factor = Antenna factor + Insertion loss (cable loss + amplifier gain)

2. Margin = Limit –MAX Peak/ Average

802.11ax (HE80) CH106

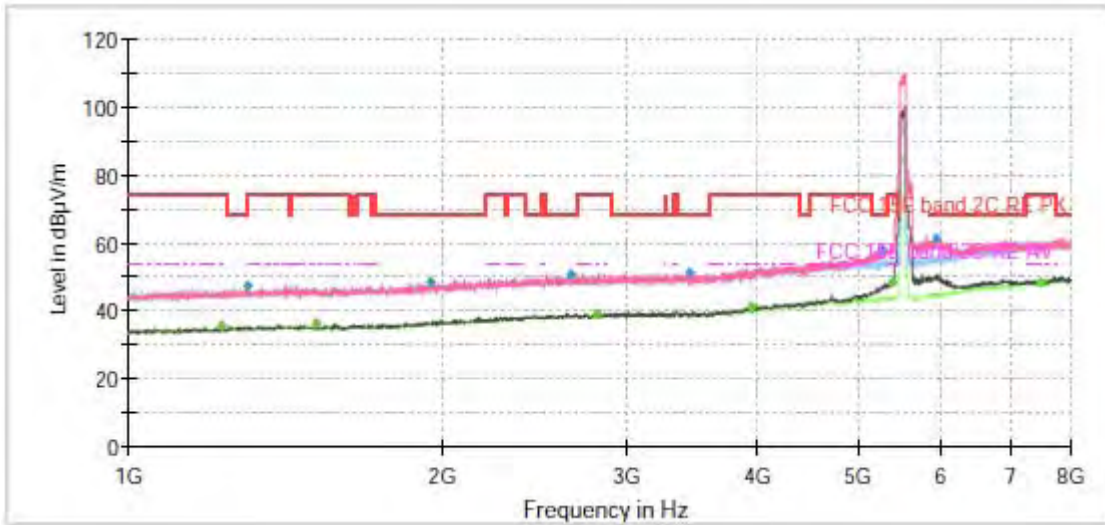

Note: The signal beyond the limit is carrier.
Radiates Emission from 1GHz to 8GHz



Radiates Emission from 8GHz to 18GHz

Frequency (MHz)	MaxPeak (dB μ V/m)	Average (dB μ V/m)	Limit (dB μ V/m)	Margin (dB)	Meas. Time (ms)	Height (cm)	Pol	Azimuth (deg)	Corr. (dB/m)
1224.88	---	35.90	54.00	18.10	500.00	100.0	H	144.00	-10
1296.63	47.49	---	68.20	20.71	500.00	100.0	V	0.00	-9
1507.50	---	36.01	54.00	17.99	500.00	200.0	H	203.00	-9
1947.63	48.83	---	68.20	19.37	500.00	100.0	V	0.00	-8
2652.00	51.00	---	68.20	17.20	500.00	100.0	V	155.00	-6
2806.88	---	38.94	54.00	15.06	500.00	100.0	H	192.00	-5
3442.13	51.20	---	68.20	17.00	500.00	100.0	V	81.00	-4
3947.88	---	41.08	54.00	12.92	500.00	200.0	V	358.00	-2
5283.13	58.16	---	68.20	10.04	500.00	200.0	V	314.00	3
5380.25	---	48.51	54.00	5.49	500.00	200.0	V	0.00	3
5942.00	61.53	---	68.20	6.67	500.00	200.0	V	0.00	4
7494.25	---	48.47	54.00	5.53	500.00	200.0	V	314.00	8

Remark: 1. Correction Factor = Antenna factor + Insertion loss (cable loss + amplifier gain)

2. Margin = Limit - MAX Peak/ Average

802.11ax (HE80) CH122

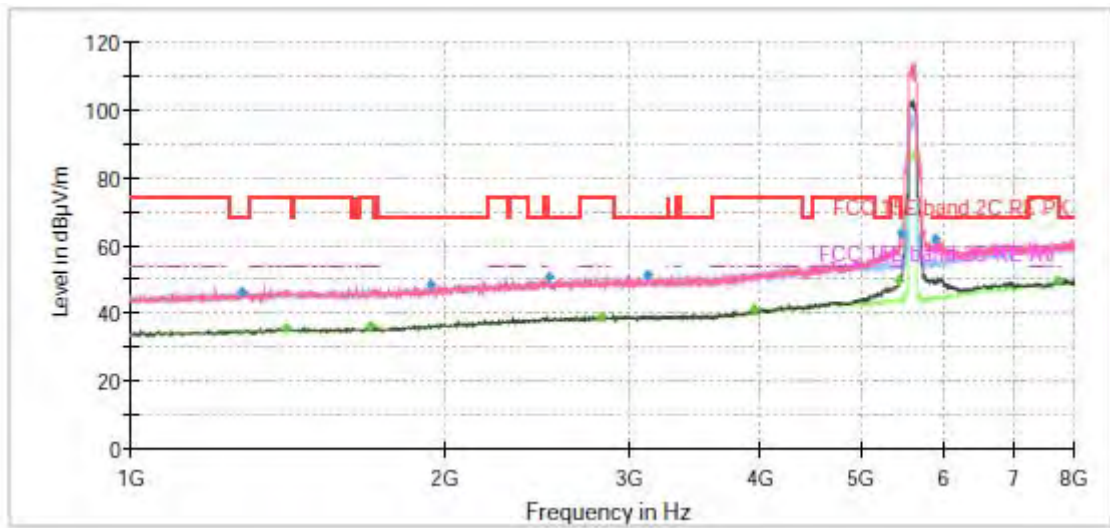

Note: The signal beyond the limit is carrier.
Radiates Emission from 1GHz to 8GHz

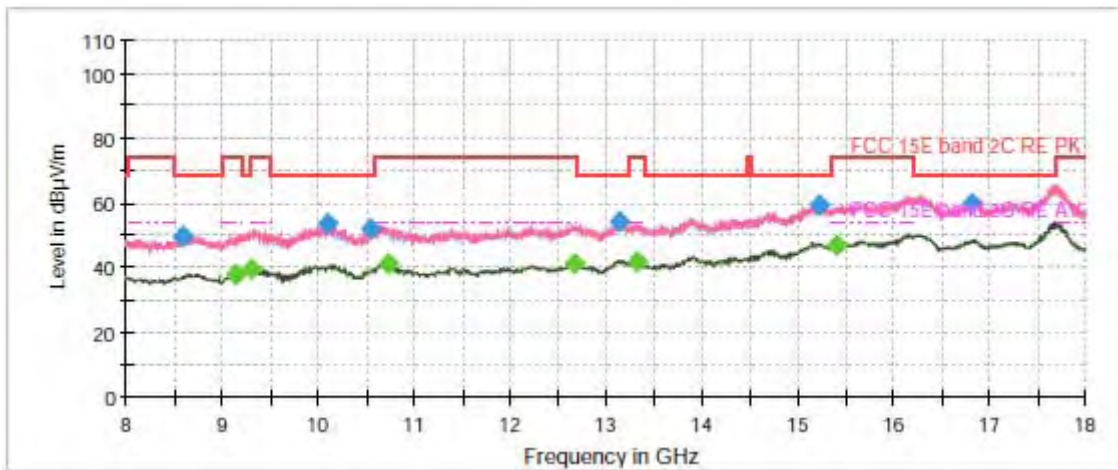

Radiates Emission from 8GHz to 18GHz

Frequency (MHz)	MaxPeak (dB μ V/m)	Average (dB μ V/m)	Limit (dB μ V/m)	Margin (dB)	Meas. Time (ms)	Height (cm)	Pol	Azimuth (deg)	Corr. (dB/m)
1278.25	46.39	---	68.20	21.81	500.00	200.0	H	8.00	-10
1407.75	---	35.85	54.00	18.15	500.00	100.0	V	101.00	-9
1696.50	---	36.01	54.00	17.99	500.00	200.0	H	2.00	-8
1938.00	48.38	---	68.20	19.82	500.00	100.0	H	352.00	-8
2518.13	50.73	---	68.20	17.47	500.00	200.0	H	136.00	-6
2817.38	---	39.23	54.00	14.77	500.00	100.0	H	357.00	-5
3126.25	51.41	---	68.20	16.79	500.00	100.0	V	141.00	-5
3954.88	---	41.11	54.00	12.89	500.00	100.0	V	181.00	-2
5447.63	---	49.80	54.00	4.20	500.00	200.0	V	0.00	3
5469.50	63.57	---	68.20	4.63	500.00	200.0	V	156.00	3
5898.25	61.74	---	68.20	6.46	500.00	200.0	V	347.00	4
7733.13	---	49.67	54.00	4.33	500.00	100.0	H	81.00	9

Remark: 1. Correction Factor = Antenna factor + Insertion loss (cable loss + amplifier gain)

2. Margin = Limit –MAX Peak/ Average

802.11ax (HE80) CH138

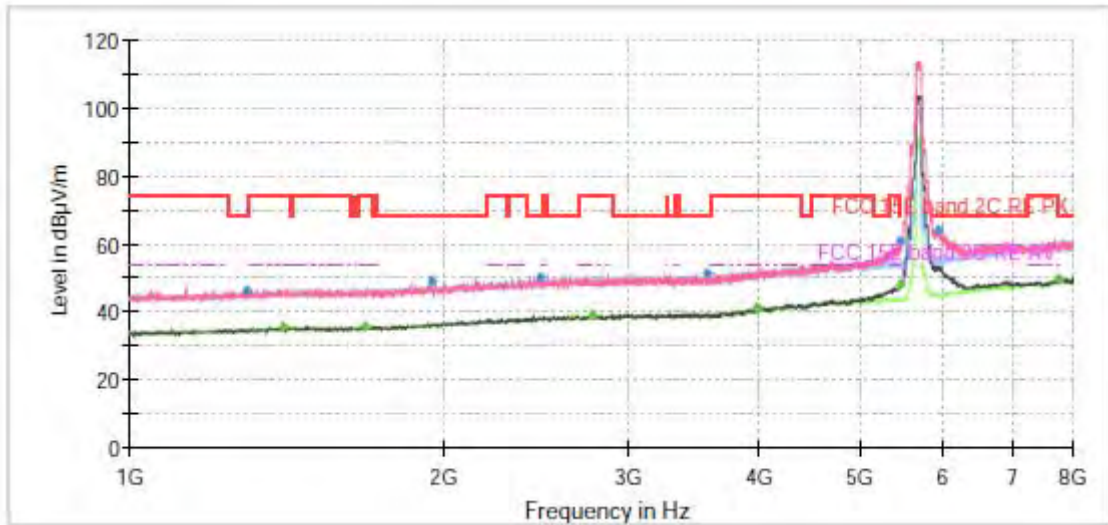

Note: The signal beyond the limit is carrier.
Radiates Emission from 1GHz to 8GHz

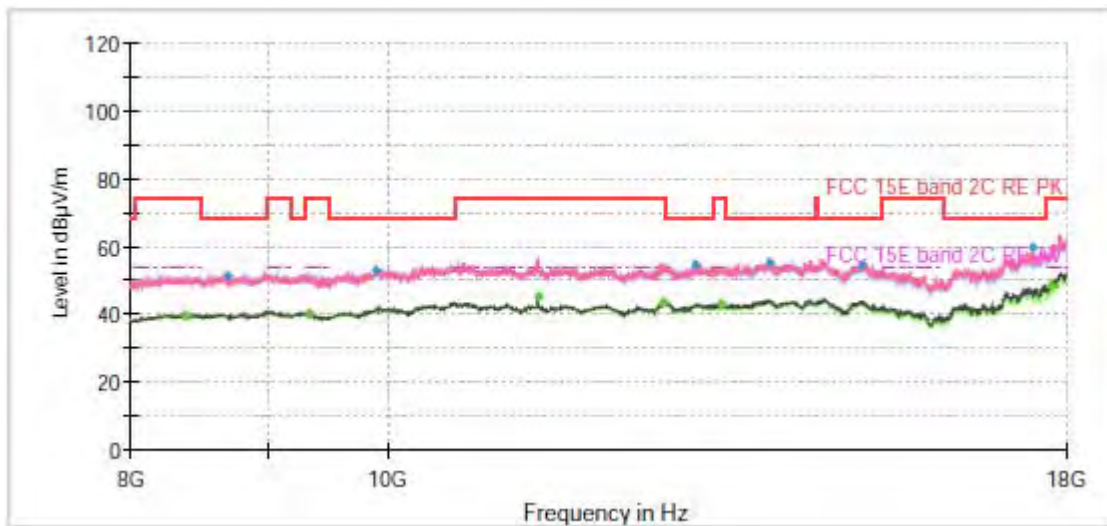

Radiates Emission from 8GHz to 18GHz

Frequency (MHz)	MaxPeak (dB μ V/m)	Average (dB μ V/m)	Limit (dB μ V/m)	Margin (dB)	Meas. Time (ms)	Height (cm)	Pol	Azimuth (deg)	Corr. (dB/m)
1295.75	46.23	---	68.20	21.97	500.00	200.0	H	32.00	-9
1403.38	---	35.71	54.00	18.29	500.00	100.0	H	110.00	-9
1679.88	---	35.89	54.00	18.11	500.00	100.0	H	358.00	-8
1941.50	49.21	---	68.20	18.99	500.00	200.0	H	113.00	-8
2468.25	50.40	---	68.20	17.80	500.00	100.0	H	319.00	-6
2769.25	---	39.04	54.00	14.96	500.00	100.0	H	110.00	-5
3562.88	51.34	---	68.20	16.86	500.00	200.0	V	205.00	-4
3984.63	---	41.13	54.00	12.87	500.00	100.0	V	96.00	-2
5456.38	---	47.84	54.00	6.16	500.00	200.0	V	0.00	3
5465.13	60.57	---	68.20	7.63	500.00	200.0	V	318.00	3
5944.63	63.92	---	68.20	4.28	500.00	200.0	V	212.00	4
7740.13	---	49.54	54.00	4.46	500.00	200.0	H	280.00	9
17737.50	---	48.41	54.00	5.59	500.00	100.0	V	0.00	11

Remark: 1. Correction Factor = Antenna factor + Insertion loss (cable loss + amplifier gain)

2. Margin = Limit - MAX Peak/ Average

802.11ax (HE80) CH155

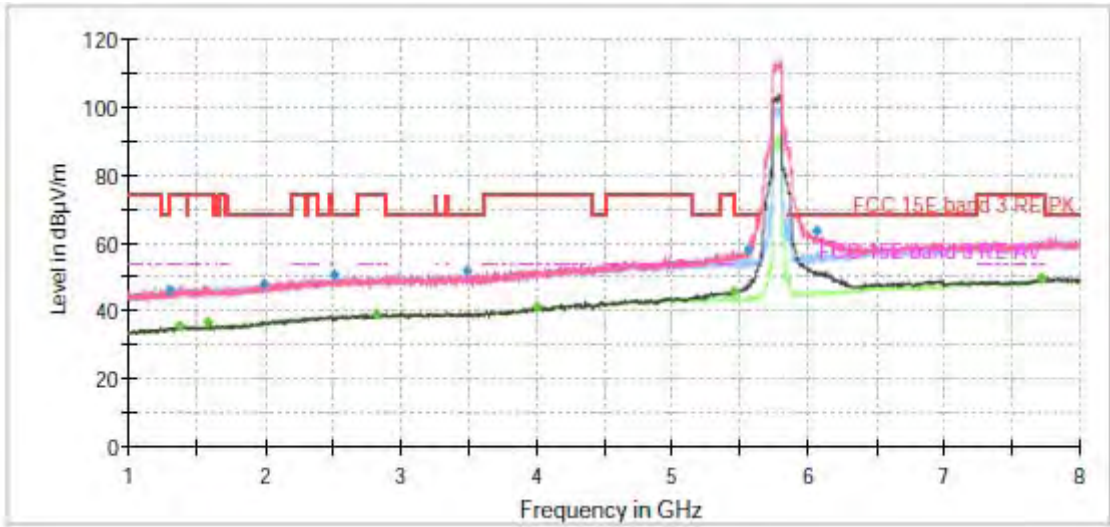

Note: The signal beyond the limit is carrier.
Radiates Emission from 1GHz to 8GHz

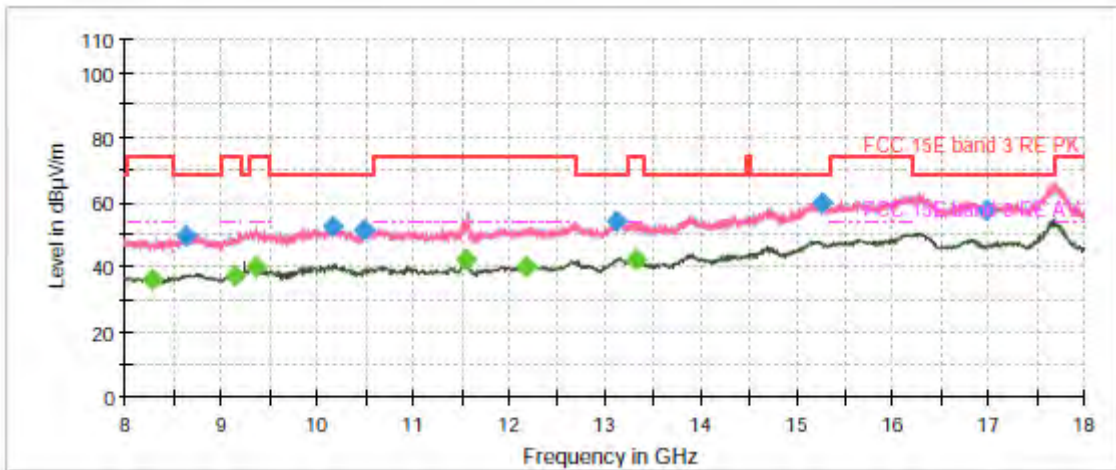

Radiates Emission from 8GHz to 18GHz

Frequency (MHz)	MaxPeak (dB μ V/m)	Average (dB μ V/m)	Limit (dB μ V/m)	Margin (dB)	Meas. Time (ms)	Height (cm)	Pol	Azimuth (deg)	Corr. (dB/m)
1294.88	46.32	---	68.20	21.88	500.00	200.0	H	52.00	-9
1377.13	---	35.53	54.00	18.47	500.00	100.0	V	222.00	-9
1579.25	---	36.72	54.00	17.28	500.00	200.0	V	359.00	-9
1984.38	47.92	---	68.20	20.28	500.00	200.0	H	224.00	-7
2507.63	50.75	---	68.20	17.45	500.00	100.0	V	275.00	-6
2820.88	---	39.04	54.00	14.96	500.00	100.0	H	236.00	-5
3484.13	51.71	---	68.20	16.49	500.00	200.0	H	224.00	-4
3999.50	---	41.05	54.00	12.95	500.00	100.0	V	36.00	-2
5455.50	---	45.90	54.00	8.10	500.00	100.0	V	8.00	3
5551.75	57.97	---	68.20	10.23	500.00	200.0	V	190.00	3
6061.00	63.36	---	68.20	4.84	500.00	200.0	V	346.00	5
7726.13	---	49.51	54.00	4.49	500.00	200.0	H	3.00	9

Remark: 1. Correction Factor = Antenna factor + Insertion loss (cable loss + amplifier gain)

2. Margin = Limit - MAX Peak/ Average

802.11ax (HE160) CH50

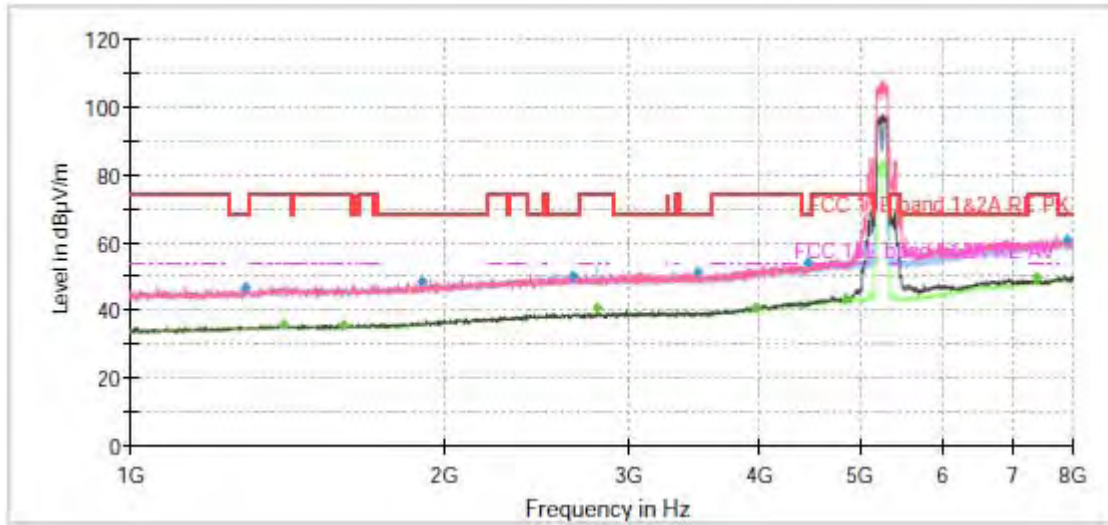

Note: The signal beyond the limit is carrier.
Radiates Emission from 1GHz to 8GHz

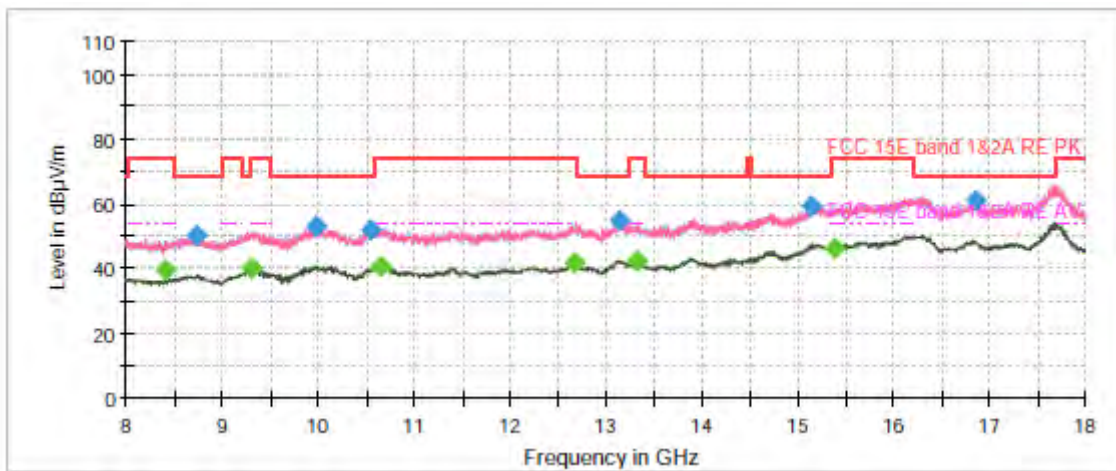

Radiates Emission from 8GHz to 18GHz

Frequency (MHz)	MaxPeak (dB μ V/m)	Average (dB μ V/m)	Limit (dB μ V/m)	Margin (dB)	Meas. Time (ms)	Height (cm)	Pol	Azimuth (deg)	Corr. (dB/m)
1286.13	46.76	---	68.20	21.44	500.00	100.0	V	240.00	-10
1399.00	---	35.76	54.00	18.24	500.00	100.0	H	165.00	-9
1596.75	---	35.96	54.00	18.04	500.00	100.0	V	247.00	-9
1899.50	48.30	---	68.20	19.90	500.00	200.0	H	274.00	-8
2653.75	50.46	---	68.20	17.74	500.00	100.0	V	35.00	-6
2799.00	---	40.85	54.00	13.15	500.00	100.0	H	0.00	-5
3492.88	51.61	---	68.20	16.59	500.00	100.0	V	288.00	-4
3966.25	---	41.01	54.00	12.99	500.00	200.0	V	138.00	-2
4449.25	54.34	---	68.20	13.86	500.00	200.0	H	199.00	-1
4849.13	---	43.51	54.00	10.49	500.00	200.0	V	321.00	1
7400.63	---	49.56	54.00	4.44	500.00	200.0	V	158.00	8
7902.00	60.99	---	68.20	7.21	500.00	100.0	V	274.00	9

Remark: 1. Correction Factor = Antenna factor + Insertion loss (cable loss + amplifier gain)

2. Margin = Limit –MAX Peak/ Average

802.11ax (HE160) CH114

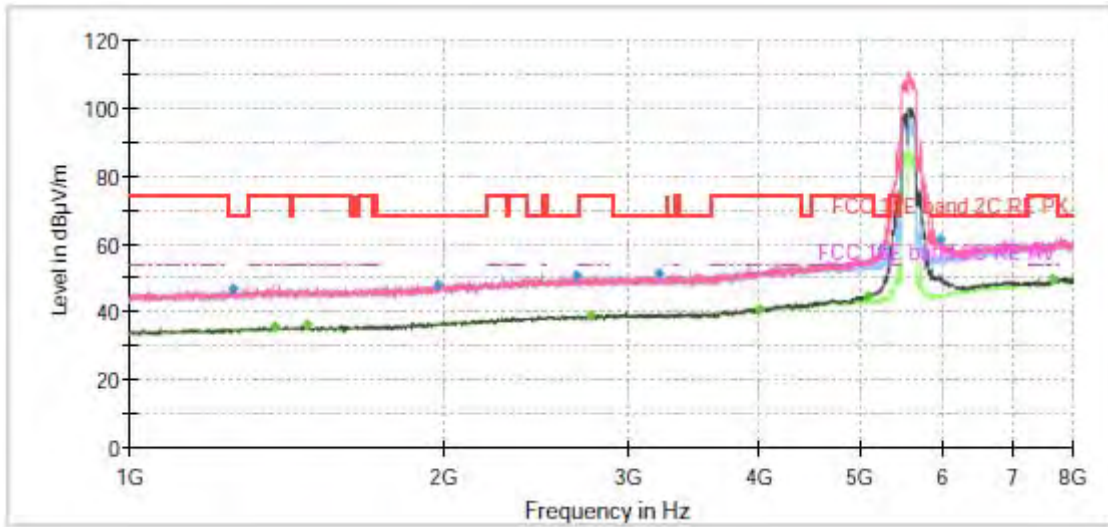

Note: The signal beyond the limit is carrier.
Radiates Emission from 1GHz to 8GHz

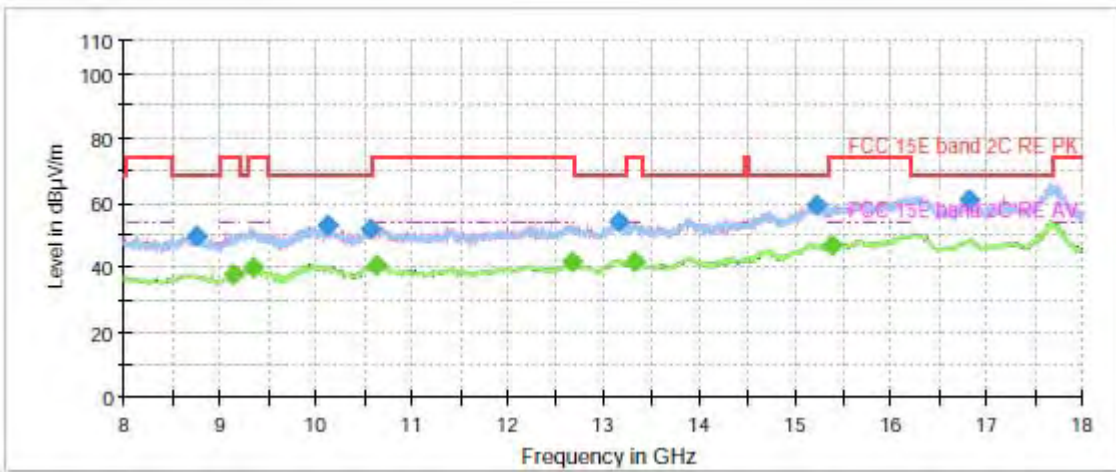

Radiates Emission from 8GHz to 18GHz

Frequency (MHz)	MaxPeak (dB μ V/m)	Average (dB μ V/m)	Limit (dB μ V/m)	Margin (dB)	Meas. Time (ms)	Height (cm)	Pol	Azimuth (deg)	Corr. (dB/m)
1254.63	47.01	---	68.20	21.19	500.00	100.0	H	310.00	-10
1374.50	---	35.80	54.00	18.20	500.00	200.0	V	350.00	-9
1476.00	---	36.03	54.00	17.97	500.00	200.0	H	88.00	-9
1966.88	48.03	---	68.20	20.17	500.00	200.0	H	123.00	-8
2680.88	50.91	---	68.20	17.29	500.00	200.0	H	5.00	-6
2764.88	---	39.13	54.00	14.87	500.00	100.0	V	22.00	-5
3214.63	51.20	---	68.20	17.00	500.00	200.0	V	0.00	-4
3997.75	---	41.02	54.00	12.98	500.00	200.0	H	55.00	-2
5094.13	---	44.83	54.00	9.17	500.00	100.0	V	4.00	2
5242.00	58.50	---	68.20	9.70	500.00	200.0	V	0.00	3
5968.25	61.63	---	68.20	6.57	500.00	200.0	V	347.00	4
7653.50	---	49.65	54.00	4.35	500.00	100.0	V	0.00	9

Remark: 1. Correction Factor = Antenna factor + Insertion loss (cable loss + amplifier gain)

2. Margin = Limit –MAX Peak/ Average

During the test, the Radiates Emission from 18GHz to 40GHz was performed in all modes with all channels, 802.11n (HT40), Channel 46 are selected as the worst condition. The test data of the worst-case condition was recorded in this report.

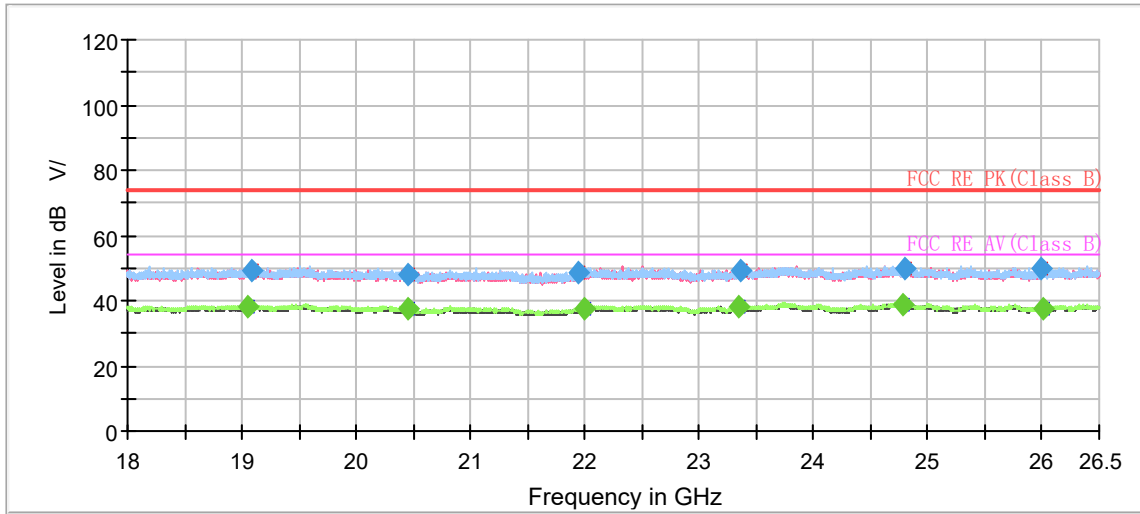

Radiates Emission from 18GHz to 26.5GHz

Frequency (MHz)	MaxPeak (dB μ V/m)	Average (dB μ V/m)	Limit (dB μ V/m)	Margin (dB)	Meas. Time (ms)	Height (cm)	Pol	Azimuth (deg)	Corr. (dB/m)
19044.466250	---	38.34	54.00	15.66	500.0	100.0	H	46.0	-5.6
19089.958750	49.47	---	74.00	24.53	500.0	200.0	V	111.0	-5.7
20445.666250	---	37.47	54.00	16.53	500.0	100.0	H	21.0	-5.1
20454.383750	47.80	---	74.00	26.20	500.0	100.0	H	193.0	-5.0
21941.073750	48.76	---	74.00	25.24	500.0	100.0	H	188.0	-4.2
21995.230000	---	37.70	54.00	16.30	500.0	200.0	V	43.0	-4.2
23343.211250	---	37.96	54.00	16.05	500.0	100.0	H	41.0	-3.4
23363.356250	48.94	---	74.00	25.06	500.0	100.0	H	307.0	-3.4
24778.380000	---	38.73	54.00	15.27	500.0	200.0	V	192.0	-2.2
24797.965000	49.79	---	74.00	24.21	500.0	200.0	V	58.0	-2.2
25996.847500	49.91	---	74.00	24.09	500.0	100.0	H	138.0	-2.5
26012.547500	---	37.80	54.00	16.20	500.0	100.0	H	26.0	-2.4

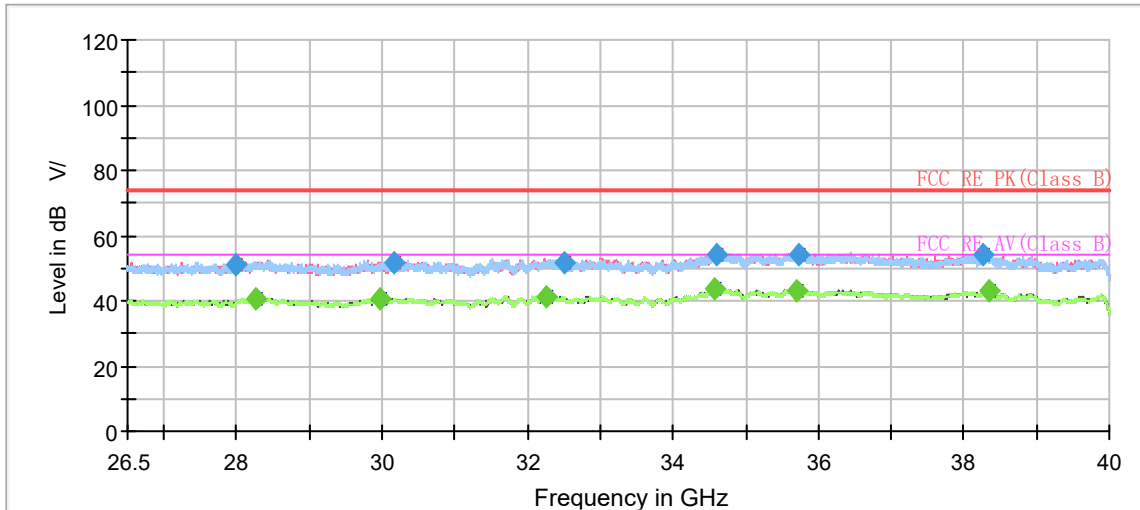

Radiates Emission from 26.5GHz to 40GHz

Frequency (MHz)	MaxPeak (dB μ V/m)	Average (dB μ V/m)	Limit (dB μ V/m)	Margin (dB)	Meas. Time (ms)	Height (cm)	Pol	Azimuth (deg)	Corr. (dB/m)
27990.236250	50.84	---	74.00	23.16	500.0	200.0	H	3.0	-0.5
28255.557500	---	40.47	54.00	13.53	500.0	200.0	H	347.0	0.0
29984.345000	---	40.78	54.00	13.22	500.0	100.0	V	5.0	-0.4
30177.716250	51.67	---	74.00	22.33	500.0	200.0	V	320.0	-0.3
32262.527500	---	41.32	54.00	12.68	500.0	100.0	H	181.0	-1.2
32493.538750	51.99	---	74.00	22.01	500.0	200.0	V	330.0	-1.1
34576.691250	---	43.48	54.00	10.52	500.0	200.0	V	335.0	2.8
34592.567500	54.26	---	74.00	19.74	500.0	100.0	V	143.0	2.8
35709.166250	---	43.20	54.00	10.80	500.0	200.0	V	250.0	3.1
35740.005000	54.00	---	74.00	20.00	500.0	200.0	V	0.0	3.1
38277.222500	53.85	---	74.00	20.15	500.0	100.0	H	101.0	3.8
38336.768750	---	43.19	54.00	10.81	500.0	100.0	H	251.0	3.7

Remark: 1. Correction Factor = Antenna factor + Insertion loss (cable loss + amplifier gain)
 2. Margin = Limit-MAX Peak/ Average

5.6. Conducted Emission

Ambient condition

Temperature	Relative humidity	Pressure
23°C ~25°C	45%~50%	101.5kPa

Methods of Measurement

The EUT IS placed on a non-metallic table of 80cm height above the horizontal metal reference ground plane. During the test, the EUT was operating in its typical mode. The test method is according to ANSI C63.10. Connect the AC power line of the EUT to the LISN Use EMI receiver to detect the average and Quasi-peak value. RBW is set to 9kHz, VBW is set to 30kHz The measurement result should include both L line and N line.

The test is in transmitting mode.

Test Setup

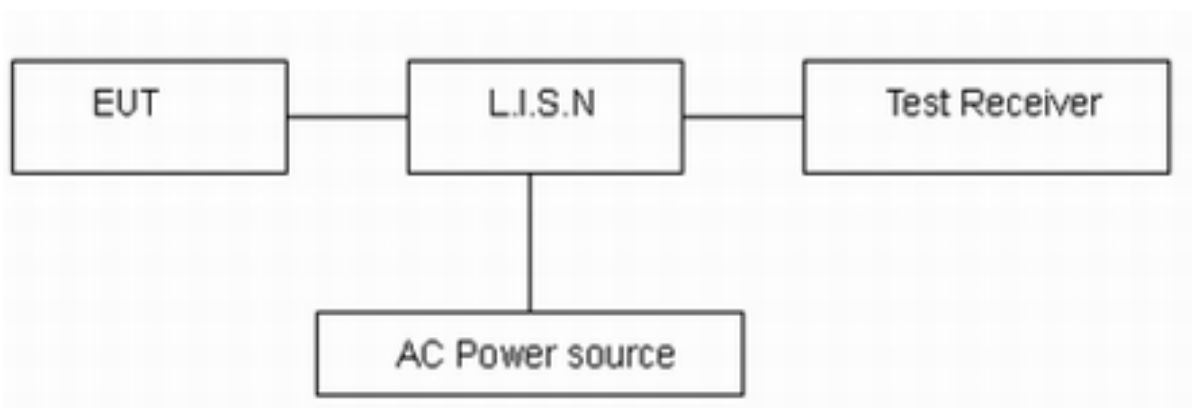

Note: AC Power source is used to change the voltage 110V/60Hz.

Limits

Frequency (MHz)	Conducted Limits(dBμV)	
	Quasi-peak	Average
0.15 - 0.5	66 to 56 *	56 to 46*
0.5 - 5	56	46
5 - 30	60	50

*: Decreases with the logarithm of the frequency.

Measurement Uncertainty

The assessed measurement uncertainty to ensure 95% confidence level for the normal distribution is with the coverage factor $k = 1.96$, $U = 2.69$ dB.

Test Results:

Following plots, Blue trace uses the peak detection and Green trace uses the average detection. During the test, the Conducted Emission was performed in all modes with all channels, 802.11n (HT40), Channel 46 are selected as the worst condition. The test data of the worst-case condition was recorded in this report.

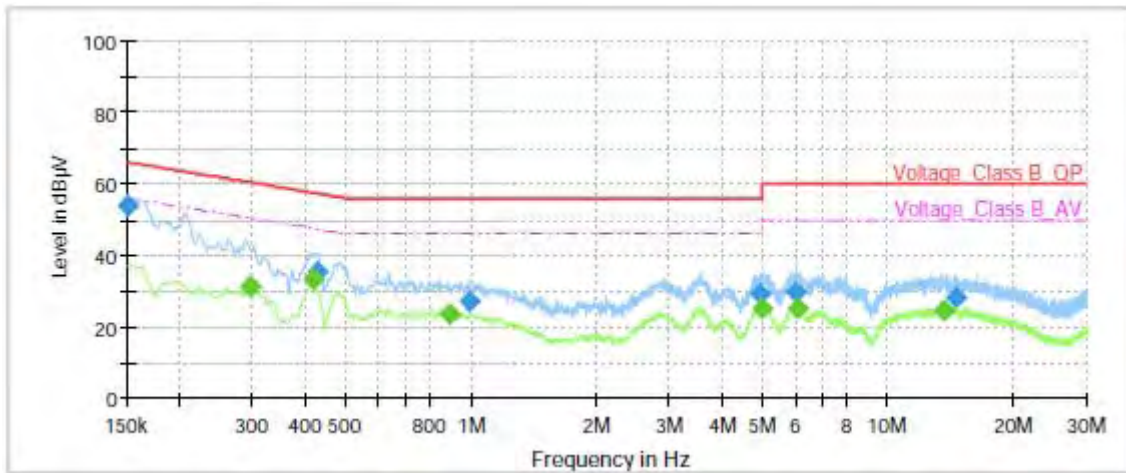

Frequency (MHz)	QuasiPeak (dBµV)	Average (dBµV)	Limit (dBµV)	Margin (dB)	Meas. Time (ms)	Bandwidth (kHz)	Line	Filter	Corr. (dB)
0.15	53.80	---	66.00	12.20	1000.0	9.000	L1	ON	21.0
0.30	---	31.19	50.35	19.16	1000.0	9.000	L1	ON	21.0
0.42	---	33.44	47.49	14.05	1000.0	9.000	L1	ON	21.0
0.43	35.27	---	57.27	22.00	1000.0	9.000	L1	ON	20.9
0.89	---	23.40	46.00	22.60	1000.0	9.000	L1	ON	20.3
0.99	27.04	---	56.00	28.96	1000.0	9.000	L1	ON	20.2
4.97	29.41	---	56.00	26.59	1000.0	9.000	L1	ON	19.5
5.00	---	25.08	46.00	20.92	1000.0	9.000	L1	ON	19.5
6.01	29.72	---	60.00	30.28	1000.0	9.000	L1	ON	19.5
6.07	---	25.23	50.00	24.77	1000.0	9.000	L1	ON	19.5
13.68	---	24.49	50.00	25.51	1000.0	9.000	L1	ON	19.6
14.58	28.40	---	60.00	31.60	1000.0	9.000	L1	ON	19.6

Remark: Correct factor=cable loss + LISN factor

L line Conducted Emission from 150 KHz to 30 MHz

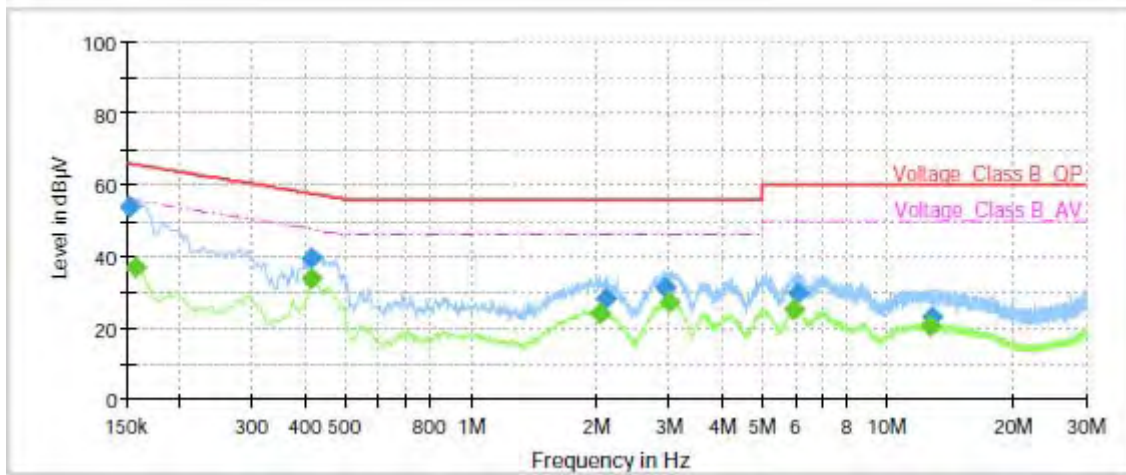

Frequency (MHz)	QuasiPeak (dBµV)	Average (dBµV)	Limit (dBµV)	Margin (dB)	Meas. Time (ms)	Bandwidth (kHz)	Line	Filter	Corr. (dB)
0.15	53.86	---	65.88	12.02	1000.0	9.000	N	ON	21.0
0.16	---	36.96	55.63	18.67	1000.0	9.000	N	ON	21.0
0.42	---	33.83	47.54	13.71	1000.0	9.000	N	ON	21.0
0.42	39.55	---	57.54	17.99	1000.0	9.000	N	ON	21.0
2.04	---	24.28	46.00	21.72	1000.0	9.000	N	ON	19.7
2.12	28.05	---	56.00	27.95	1000.0	9.000	N	ON	19.7
2.93	31.50	---	56.00	24.50	1000.0	9.000	N	ON	19.6
3.01	---	27.06	46.00	18.94	1000.0	9.000	N	ON	19.6
5.95	---	25.14	50.00	24.86	1000.0	9.000	N	ON	19.5
6.07	29.91	---	60.00	30.09	1000.0	9.000	N	ON	19.5
12.60	---	20.53	50.00	29.47	1000.0	9.000	N	ON	19.6
12.80	23.18	---	60.00	36.82	1000.0	9.000	N	ON	19.6

Remark: Correct factor=cable loss + LISN factor

N line Conducted Emission from 150 KHz to 30 MHz

6. Main Test Instruments

Name	Manufacturer	Type	Serial Number	Calibration Date	Expiration Date
Spectrum Analyzer	KEYSIGHT	N9020A	MY51330870	2023-05-12	2024-05-11
Power Sensor	R&S	NRP18S	101954	2023-05-12	2024-05-11
DC Power Supply	UNI-T	UTP1306S+	2205D0517426	2022-12-10	2023-12-09
Temperature Chamber	ESPEC	SU-242	93000506	2022-12-10	2023-12-09
Radiated Emission					
EMI Test Receiver	R&S	ESC13	100948	2023-05-12	2024-05-11
Signal Analyzer	R&S	FSV40	101298	2023-05-12	2024-05-11
Loop Antenna	SCHWARZBECK	FMZB1519	1519-047	2023-04-16	2026-04-15
TRILOG Broadband Antenna	SCHWARZBECK	VULB 9163	01111	2022-10-25	2025-10-24
Horn Antenna	R&S	HF907	102723	2021-07-24	2024-07-23
Horn Antenna	ETS-Lindgren	3160-09	00102643	2021-10-10	2024-10-09
Horn Antenna	STEATITE	QSH-SL-26-40-K-15	16779	2023-01-17	2026-01-16
Software	R&S	EMC32	9.26.01	/	/
Conducted Emission					
Artificial main network	R&S	ENV216	102191	2022-12-13	2024-12-09
EMI Test Receiver	R&S	ESR	101667	2023-05-12	2024-05-11
Software	R&S	EMC32	10.35.10	/	/

ANNEX A: The EUT Appearance

The EUT Appearance are submitted separately.

ANNEX B: Test Setup Photos

The Test Setup Photos are submitted separately.

***** END OF REPORT *****