



中国认可
国际互认
检测
TESTING
CNAS L2264

EMC TEST REPORT

Applicant Alcatel-Lucent Shanghai Bell Co. Ltd.
FCC ID 2ADZRG120WF
Product GPON ONU
Model G-120W-F
Brand NOKIA
Report No. YBA1704-0038EMC01R1
Issue Date June 23 ,2017

TA Technology (Shanghai) Co., Ltd. tested the above equipment in accordance with the requirements in **FCC Code CFR47 Part15B (2016)/ ANSI C63.4 (2014)**. The test results show that the equipment tested is capable of demonstrating compliance with the requirements as documented in this report.

Wei Liu

Guangchang Fan

Performed by: Wei Liu/ Manager

Approved by: Guangchang Fan/ Director

TA Technology (Shanghai) Co., Ltd.

No.145, Jintang Rd, Tangzhen Industry Park, Pudong Shanghai, China

TEL: +86-021-50791141/2/3

FAX: +86-021-50791141/2/3-8000



Table of Contents

1	Test Laboratory.....	4
1.1	Notes of the Test Report.....	4
1.2	Test facility.....	4
1.3	Testing Location.....	5
2	General Description of Equipment under Test.....	6
2.1	Client Information.....	6
2.2	General information.....	6
2.3	Applied Standards.....	7
2.4	Test Mode.....	8
3	Test Case Results.....	9
3.1	Radiated Emission.....	9
3.2	Conducted Emission.....	15
4	Main Test Instrument.....	18
	ANNEX A: The EUT Appearance and Test Configuration.....	19
	A.1 EUT Appearance.....	19
	A.2 Test Setup.....	21
	A.3 Host Product.....	23



Summary of measurement results

Number	Test Case	Clause in FCC Rules	Conclusion
1	Radiated Emission	15.109, ANSI C63.4-2014	PASS
2	Conducted Emission	15.107, ANSI C63.4-2014	PASS
Date of Testing: June 1, 2017 ~ June 15, 2017			



1 Test Laboratory

1.1 Notes of the Test Report

This report shall not be reproduced in full or partial, without the written approval of **TA technology (shanghai) co., Ltd.** The results documented in this report apply only to the tested sample, under the conditions and modes of operation as described herein .Measurement Uncertainties were not taken into account and are published for informational purposes only. This report is written to support regulatory compliance of the applicable standards stated above. This report must not be used by the client to claim product certification, approval, or endorsement by any government agencies.

1.2 Test facility

CNAS (accreditation number: L2264)

TA Technology (Shanghai) Co., Ltd. has obtained the accreditation of China National Accreditation Service for Conformity Assessment (CNAS).

FCC (recognition number is 428261)

TA Technology (Shanghai) Co., Ltd. has been listed on the US Federal Communications Commission list of test facilities recognized to perform electromagnetic emissions measurements.

IC (recognition number is 8510A)

TA Technology (Shanghai) Co., Ltd. has been listed by industry Canada to perform electromagnetic emission measurement.

VCCI (recognition number is C-4595, T-2154, R-4113, G-10766)

TA Technology (Shanghai) Co., Ltd. has been listed by industry Japan to perform electromagnetic emission measurement.

A2LA (Certificate Number: 3857.01)

TA Technology (Shanghai) Co., Ltd. has been listed by American Association for Laboratory Accreditation to perform electromagnetic emission measurement.



1.3 Testing Location

Company: TA Technology (Shanghai) Co., Ltd.
Address: No.145, Jintang Rd, Tangzhen Industry Park, Pudong Shanghai, China
City: Shanghai
Post code: 201201
Country: P. R. China
Contact: Xu Kai
Telephone: +86-021-50791141/2/3
Fax: +86-021-50791141/2/3-8000
Website: <http://www.ta-shanghai.com>
E-mail: xukai@ta-shanghai.com

2 General Description of Equipment under Test

2.1 Client Information

Applicant	Alcatel-Lucent Shanghai Bell Co.Ltd.
Applicant address	388-389#,Ningqiao Road,Pudong Jinqiao, Shanghai P. R. China
Manufacturer	TAICANG T&W ELECTRONICS CO., LTD
Manufacturer address	Jiangnan Road 89, Loudong Street, Taicang, Jiangsu, P. R. China

2.2 General information

EUT Description	
Device Type:	Portable Device
Model Number:	G-120W-F
SN:	/
Kit Code:	3FE47000AAAA
HW Version:	PEM 2
SW Version:	3FE46302AFE40
Antenna Type:	External Antenna
Used Host Product:	Manufacturer: lenovo PC Model: Thinkpad T540p (SN : SL10E37685)
Test Mode:	Transfer Data Mode
EUT Accessory	
Adapter	Manufacturer: SHENZHEN RUIDE ELECTRONICAL INDUSTRIAL CO., LTD Model: RD1201000-C55-26MG Input power:100-240 VAC 50-60Hz 0.6A Output power:12.0V DC 1.0A
Remark: The information of the EUT is declared by the manufacturer. Please refer to the specifications or user manual for details.	



2.3 Applied Standards

According to the specifications of the manufacturer, it must comply with the requirements of the following standards:

Test standards

FCC Code CFR47 Part15B (2016)

ANSI C63.4 (2014)

2.4 Test Mode

Test Mode	
Mode 1:	Adapter + Ethernet + Idle
Mode 2:	Adapter + Ethernet + Traffic
Mode 3:	Adapter + Telephone + Ethernet + Idle
Mode 4:	Adapter + Telephone + Ethernet + Traffic

During the test, the preliminary test was performed in all modes with all frequency bands, mode 2 selected as the worst condition. The test data of the worst-case condition was recorded in this report.

3 Test Case Results

3.1 Radiated Emission

Ambient condition

Temperature	Relative humidity	Pressure
24°C~26°C	45%~50%	102.5kPa

Methods of Measurement

The EUT is placed on a non-metallic table 0.8m above the horizontal metal reference ground plane. The distance between EUT and receive antenna should be 3 meters. During the test, the EUT was operating in its typical mode. The test method is according to ANSI C63.4-2014. Sweep the whole frequency band through the range from 30MHz to the 5th harmonic of the carrier. During the test, the height of receive antenna shall be moved from 1 to 4 meters, and the antenna shall be performed under horizontal and vertical polarization. The turn table shall be rotated from 0 to 360 degrees for detecting the maximum of radiated signal level.

The data of cable loss and antenna factor has been calibrated in full testing frequency range before the testing. During the test, the EUT is worked at maximum output power.

Set the spectrum analyzer in the following:

Below 1GHz:

RBW=100 kHz / VBW=300 kHz / Sweep=AUTO

Above 1GHz:

(a) PEAK: RBW=1MHz / VBW=3MHz/ Sweep=AUTO

(b) AVERAGE: RBW=1MHz / VBW=3MHz / Sweep=AUTO

The radiated emission was measured in the following position: EUT stand-up position (Z axis), lie-down position (X, Y axis). The worst emission was found in stand-up position (Z axis) and the worst case was recorded.

During the test, EUT is connected to a laptop via a USB cable in the case of Transfer Data mode. The EUT is used as the peripheral equipment of the PC. The data is transferred from EUT to PC; PC is connected to server via a long LAN cable.

Test Setup

Below 1GHz

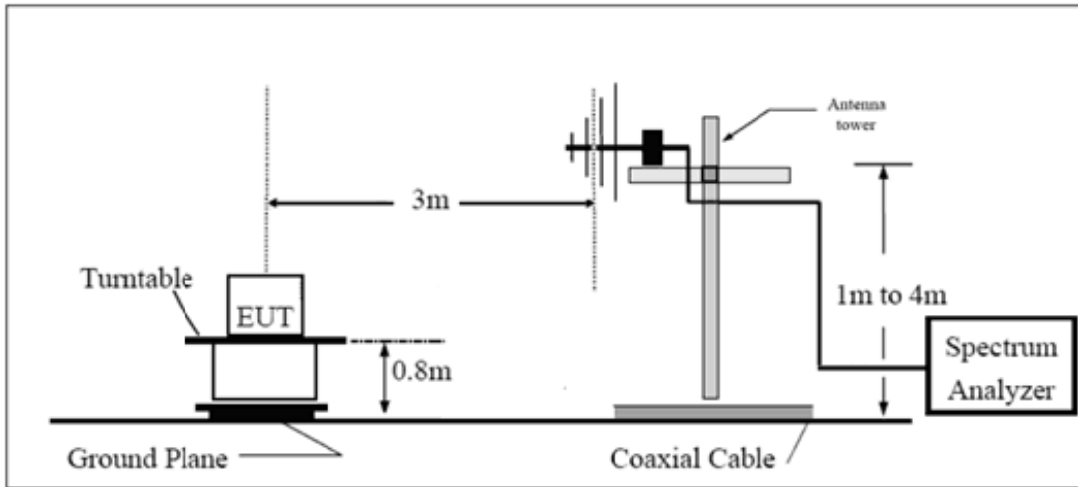

Above 1GHz

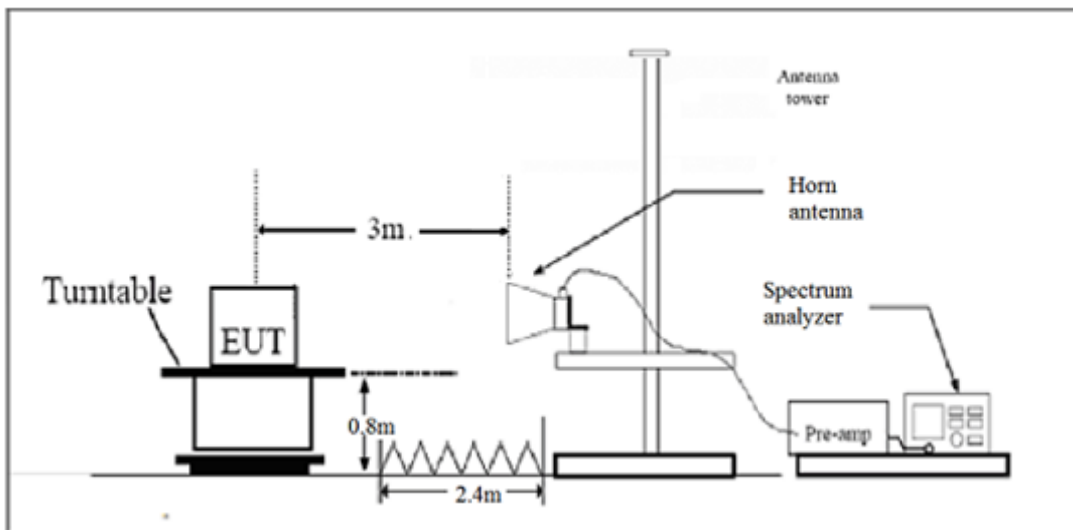

Note: Area side:2.4mX3.6m

Antenna Tower meets ANSI C63.4 requirements for measurements above 1 GHz by keeping the antenna aimed at the EUT during the antenna's ascent/ descent along the antenna mast.

**Limits**

Frequency (MHz)	Field Strength (dB μ V/m)	Detector
30 -88	40.0	Quasi-peak
88-216	43.5	Quasi-peak
216 – 960	46.0	Quasi-peak
960-1000	54.0	Quasi-peak
1000-5 th harmonic of the highest frequency or 40GHz, which is lower	54 74	Average Peak

Measurement Uncertainty

The assessed measurement uncertainty to ensure 95% confidence level for the normal distribution is with the coverage factor $k = 1.96$. $U = 3.92$ dB.

Test Results

The following graphs display the maximum values of horizontal and vertical by software.
 For above 1GHz, Blue trace uses the peak detection, Green trace uses the average detection.

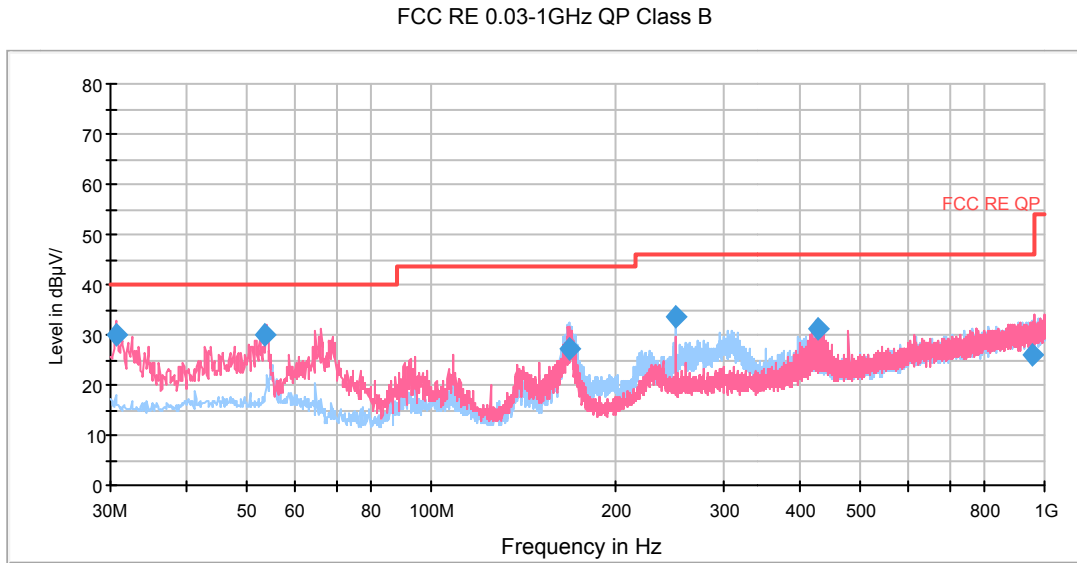

Radiated Emission from 30MHz to 1GHz

Frequency (MHz)	Quasi-Peak (dBuV/m)	Reading value (dBuV/m)	Height (cm)	Polarization	Azimuth (deg)	Correct Factor (dB)	Margin (dB)	Limit (dBuV/m)
30.606250	30.0	17.9	100.0	V	347.0	12.1	10.0	40.0
53.566250	30.2	17.4	100.0	V	63.0	12.8	9.8	40.0
167.980000	27.1	16.7	125.0	H	120.0	10.4	16.4	43.5
249.988750	33.6	19.2	125.0	H	96.0	14.4	12.4	46.0
428.831250	31.3	12.3	125.0	V	59.0	19.0	14.7	46.0
957.963750	26.0	-1.3	100.0	H	223.0	27.3	20.0	46.0

- Remark:**
1. Quasi-Peak = Reading value + Correction factor
 2. Correction Factor = Antenna factor+ Insertion loss(cable loss+amplifier gain)
 3. Margin = Limit – Quasi-Peak

RE 1G-3GHz PK+AV

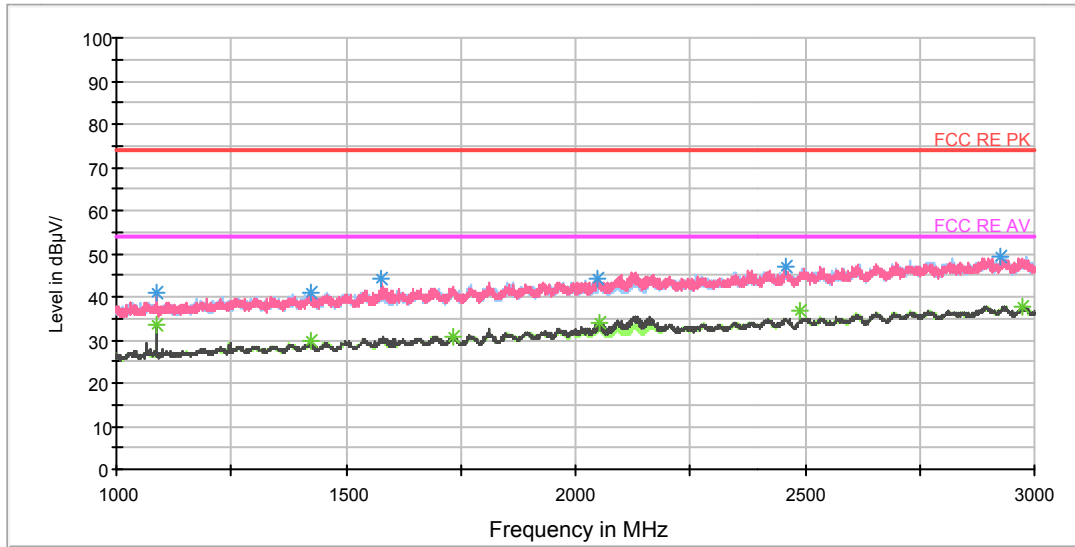

Radiated Emission from 1GHz to 3GHz

Frequency (MHz)	Peak (dBuV/m)	Reading value (dBuV/m)	Height (cm)	Polarization	Azimuth (deg)	Correct Factor (dB)	Margin (dB)	Limit (dBuV/m)
1087.250000	41.0	49.9	100.0	V	133.0	-8.9	33.0	74
1425.250000	40.9	47.8	100.0	V	133.0	-6.9	33.1	74
1578.500000	44.0	50.3	100.0	V	125.0	-6.3	30.0	74
2046.250000	44.4	47.6	100.0	V	107.0	-3.2	29.6	74
2457.500000	46.8	47.3	100.0	V	0.0	-0.5	27.2	74
2925.500000	49.4	47.7	200.0	V	314.0	1.7	24.6	74

Frequency (MHz)	Average (dBuV/m)	Reading value (dBuV/m)	Height (cm)	Polarization	Azimuth (deg)	Correct Factor (dB)	Margin (dB)	Limit (dBuV/m)
1087.500000	33.5	42.4	100.0	V	133.0	-8.9	20.5	54
1422.750000	29.5	36.4	300.0	V	271.0	-6.9	24.5	54
1731.500000	30.8	35.6	300.0	H	318.0	-4.8	23.2	54
2054.500000	33.7	36.9	200.0	V	262.0	-3.2	20.3	54
2488.250000	36.6	36.4	100.0	V	54.0	0.2	17.4	54
2975.250000	37.9	35.7	200.0	V	340.0	2.2	16.1	54

RE 3-18GHz PK+AV

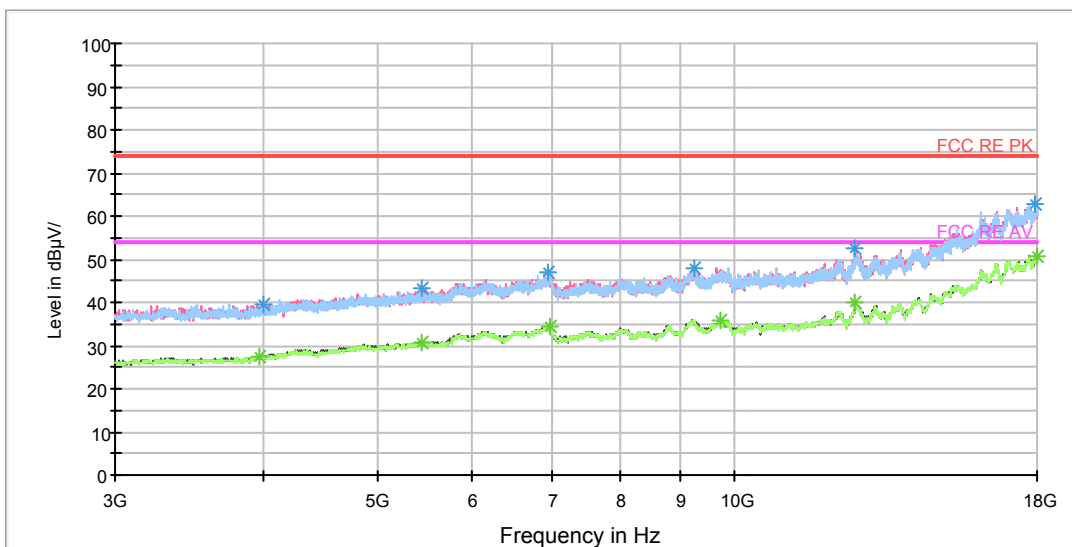

Radiated Emission from 3GHz to 18GHz

Frequency (MHz)	Peak (dBuV/m)	Reading value (dBuV/m)	Height (cm)	Polarization	Azimuth (deg)	Correct Factor (dB)	Margin (dB)	Limit (dBuV/m)
4001.250000	39.8	40.9	100.0	V	164.0	-1.1	34.2	74
5439.375000	43.2	40.3	100.0	V	0.0	2.9	30.8	74
6946.875000	46.8	40.6	100.0	H	60.0	6.2	27.2	74
9238.125000	48.1	38.2	100.0	V	164.0	9.9	25.9	74
12643.125000	52.3	37.9	100.0	H	0.0	14.4	21.7	74
17936.250000	62.8	37.7	100.0	V	220.0	25.1	11.2	74

Frequency (MHz)	Average (dBuV/m)	Reading value (dBuV/m)	Height (cm)	Polarization	Azimuth (deg)	Correct Factor (dB)	Margin (dB)	Limit (dBuV/m)
4001.250000	27.2	28.3	100.0	V	164.0	-1.1	26.8	54
5439.375000	30.5	27.6	100.0	V	0.0	2.9	23.5	54
6946.875000	33.6	27.4	100.0	H	60.0	6.2	20.4	54
9238.125000	35.9	26.0	100.0	V	164.0	9.9	18.1	54
12643.125000	39.7	25.3	100.0	H	0.0	14.4	14.3	54
17936.250000	49.5	24.4	100.0	V	220.0	25.1	4.5	54

3.2 Conducted Emission

Ambient condition

Temperature	Relative humidity	Pressure
24°C ~26°C	50%~55%	102.5kPa

Methods of Measurement

The EUT is placed on a non-metallic table of 80cm height above the horizontal metal reference ground plane. During the test, the EUT was operating in its typical mode. The test method is according to ANSI C63.4-2014. Connect the AC power line of the EUT to the L.I.S.N. Use EMI receiver to detect the average and Quasi-peak value. RBW is set to 9 kHz, VBW is set to 30kHz. The measurement result should include both L line and N line.

During the test, EUT is connected to a laptop via a USB cable in the case of Transfer Data mode. The EUT is used as the peripheral equipment of the PC. The data is transferred from EUT to PC; PC is connected to server via a long LAN cable.

Test Setup

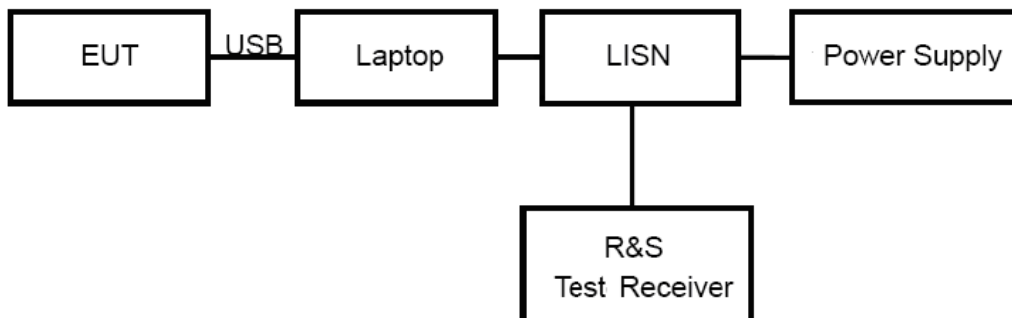

Note: Power Supply is AC Power source and it is used to change the voltage 120V/60Hz.

Limits

Frequency (MHz)	Conducted Limits(dBμV)	
	Quasi-peak	Average
0.15 - 0.5	66 to 56 *	56 to 46 *
0.5 - 5	56	46
5 - 30	60	50

*: Decreases with the logarithm of the frequency.

Measurement Uncertainty

The assessed measurement uncertainty to ensure 95% confidence level for the normal distribution is with the coverage factor $k = 1.96$. $U = 2.69$ dB.

Test Results

Following plots, Blue trace uses the peak detection; Green trace uses the average detection.

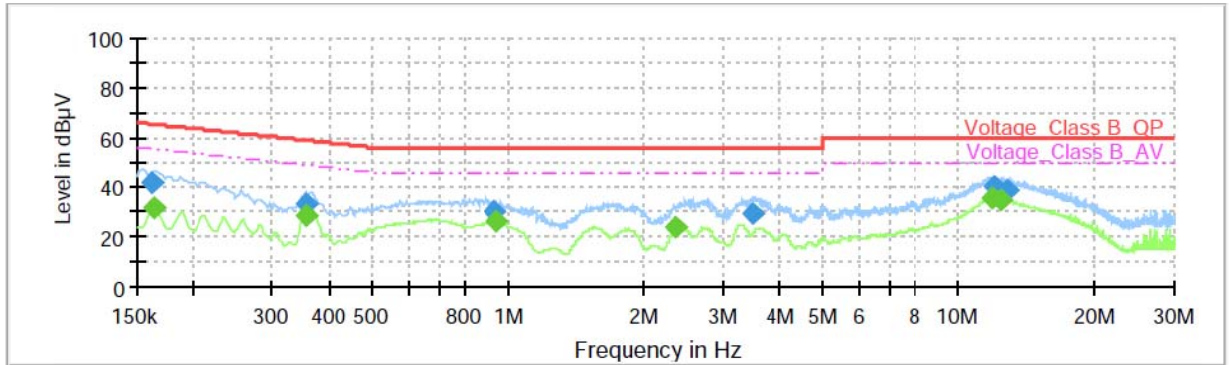

Final Result

Frequency (MHz)	QuasiPeak (dBµV)	Average (dBµV)	Limit (dBµV)	Margin (dB)	Meas. Time (ms)	Bandwidth (kHz)	Line	Filter	Corr. (dB)
0.161250	41.74	---	65.40	23.66	1000.0	9.000	L1	ON	19.1
0.163500	---	31.63	55.28	23.66	1000.0	9.000	L1	ON	19.1
0.354750	---	28.44	48.85	20.41	1000.0	9.000	L1	ON	19.2
0.357000	33.44	---	58.80	25.36	1000.0	9.000	L1	ON	19.2
0.928500	30.53	---	56.00	25.47	1000.0	9.000	L1	ON	19.2
0.937500	---	26.06	46.00	19.94	1000.0	9.000	L1	ON	19.2
2.341500	---	23.87	46.00	22.13	1000.0	9.000	L1	ON	19.0
3.486750	29.08	---	56.00	26.92	1000.0	9.000	L1	ON	19.1
11.892750	---	35.86	50.00	14.14	1000.0	9.000	L1	ON	19.4
12.014250	40.02	---	60.00	19.98	1000.0	9.000	L1	ON	19.4
12.444000	---	35.17	50.00	14.83	1000.0	9.000	L1	ON	19.4
12.799500	38.78	---	60.00	21.22	1000.0	9.000	L1	ON	19.5

L line

Conducted Emission from 150 KHz to 30 MHz

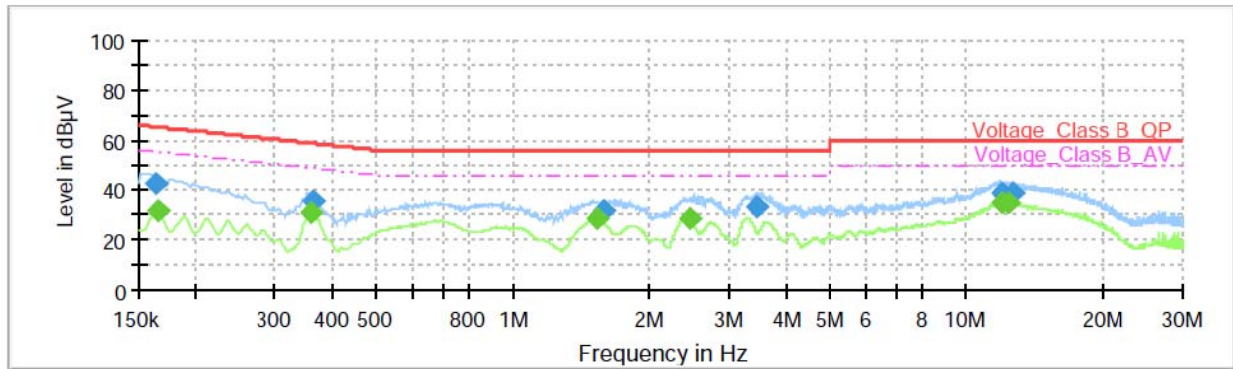

Final Result

Frequency (MHz)	QuasiPeak (dBµV)	Average (dBµV)	Limit (dBµV)	Margin (dB)	Meas. Time (ms)	Bandwidth (kHz)	Line	Filter	Corr. (dB)
0.163500	42.48	---	65.28	22.81	1000.0	9.000	N	ON	19.1
0.165750	---	31.73	55.17	23.44	1000.0	9.000	N	ON	19.2
0.359250	---	30.69	48.75	18.05	1000.0	9.000	N	ON	19.2
0.361500	35.37	---	58.69	23.33	1000.0	9.000	N	ON	19.2
1.529250	---	28.87	46.00	17.13	1000.0	9.000	N	ON	19.2
1.592250	31.50	---	56.00	24.50	1000.0	9.000	N	ON	19.2
2.458500	---	28.74	46.00	17.26	1000.0	9.000	N	ON	19.0
3.459750	33.30	---	56.00	22.70	1000.0	9.000	N	ON	19.0
11.935500	39.14	---	60.00	20.86	1000.0	9.000	N	ON	19.4
12.027750	---	34.87	50.00	15.13	1000.0	9.000	N	ON	19.4
12.439500	---	34.63	50.00	15.37	1000.0	9.000	N	ON	19.4
12.705000	38.56	---	60.00	21.44	1000.0	9.000	N	ON	19.5

N line

Conducted Emission from 150 KHz to 30 MHz

4 Main Test Instrument

Name	Manufacturer	Type	Serial Number	Last Cal.	Cal. Due Date
Signal Analyzer	R&S	FSV30	100815	2016-12-16	2017-12-15
EMI Test Receiver	R&S	ESCI	100948	2017-05-20	2018-05-19
Loop Antenna	SCHWARZBECK	FMZB1519	1519-047	2017-02-18	2019-02-17
Trilog Antenna	SCHWARZBECK	VULB 9163	9163-201	2014-12-06	2017-12-05
Horn Antenna	R&S	HF907	100126	2014-12-06	2017-12-05
Horn Antenna	ETS-Lindgren	3160-09	00102643	2015-01-30	2018-01-29
EMI Test Receiver	R&S	ESCS30	100138	2016-12-16	2017-12-15
LISN	R&S	ENV216	101171	2016-12-16	2019-12-15
Bore Sight Antenna mast	ETS	2171B	00058752	NA	NA

ANNEX A: The EUT Appearance and Test Configuration

A.1 EUT Appearance



Picture 1-1: EUT



Picture 1-2: Adapter
Picture 1 EUT

A.2 Test Setup



a: Below 1GHz



b: Above 1GHz

Picture 2 Radiated Emission Test Setup



Picture 3 Conducted Emission Test Setup

A.3 Host Product

