



# FCC RF Test Report

APPLICANT : Nokia Shanghai Bell Co., Ltd.  
EQUIPMENT : Nokia FastMile 5G Gateway 12  
BRAND NAME : Nokia  
MODEL NAME : 5G31-03W-B  
FCC ID : 2ADZR5G3103WB  
STANDARD : 47 CFR Part 2, and 90(S)  
CLASSIFICATION : PCS Licensed Transmitter (PCB)  
TEST DATE(S) : Apr. 05, 2024 ~ May 09, 2024

We, Sporton International Inc. (Kunshan), would like to declare that the tested sample has been evaluated in accordance with the procedures given in ANSI C63.26-2015 and shown compliance with the applicable technical standards.

This report contains data that were produced under subcontract by Sporton International Inc. (Shenzhen)

The test results in this report apply exclusively to the tested model / sample. Without written approval of Sporton International Inc. (Kunshan), the test report shall not be reproduced except in full.

Jason Jia



Approved by: Jason Jia

**Sporton International Inc. (Kunshan)**

No. 1098, Pengxi North Road, Kunshan Economic Development Zone Jiangsu Province 215300  
People's Republic of China



# TABLE OF CONTENTS

**REVISION HISTORY..... 3**

**SUMMARY OF TEST RESULT ..... 4**

**1 GENERAL DESCRIPTION ..... 5**

1.1 Applicant..... 5

1.2 Manufacturer ..... 5

1.3 Feature of Equipment Under Test..... 5

1.4 Product Specification of Equipment Under Test ..... 6

1.5 Modification of EUT ..... 6

1.6 Maximum Conducted Power and Emission Designator ..... 6

1.7 Testing Site..... 6

1.8 Test Software ..... 7

1.9 Applied Standards ..... 7

**2 TEST CONFIGURATION OF EQUIPMENT UNDER TEST ..... 8**

2.1 Test Mode..... 8

2.2 Connection Diagram of Test System ..... 9

2.3 Support Unit used in test configuration and system ..... 9

2.4 Measurement Results Explanation Example ..... 9

2.5 Frequency List of Low/Middle/High Channels ..... 10

**3 TEST RESULT ..... 11**

3.1 Conducted Output Power Measurement ..... 11

3.2 99% Occupied Bandwidth and 26dB Bandwidth Measurement..... 12

3.3 Emissions Mask Measurement ..... 13

3.4 Emissions Mask – Out Of Band Emissions Measurement..... 15

3.5 Field Strength of Spurious Radiation Measurement ..... 16

3.6 Frequency Stability Measurement..... 19

**4 LIST OF MEASURING EQUIPMENT ..... 21**

**5 MEASUREMENT UNCERTAINTY ..... 22**

**APPENDIX A. TEST RESULTS OF CONDUCTED TEST**

**APPENDIX B. TEST RESULTS OF RADIATED TEST**

**APPENDIX C. TEST SETUP PHOTOGRAPHS**





### SUMMARY OF TEST RESULT

Report Section	FCC Rule	Description	Limit	Result	Remark
3.1	§2.1046	Conducted Output Power	—	Report only	-
3.2	§2.1049 §90.209	Occupied Bandwidth and 26dB Bandwidth	—	Report only	-
3.3	§2.1051 §90.691	Emission masks – In-band emissions	$< 50+10\log_{10}(P[\text{Watts}])$	PASS	-
3.4	§2.1051 §90.691	Emission masks – Out of band emissions	$< 43+10\log_{10}(P[\text{Watts}])$	PASS	-
3.5	§2.1053 §90.691	Field Strength of Spurious Radiation	$< 43+10\log_{10}(P[\text{Watts}])$	PASS	Under limit 46.58 dB at 2448.000 MHz
3.6	§2.1055 §90.213	Frequency Stability for Temperature & Voltage	$< 2.5 \text{ ppm}$	PASS	-

**Conformity Assessment Condition:**

1. The test results (PASS/FAIL) with all measurement uncertainty excluded are presented against the regulation limits or in accordance with the requirements stipulated by the applicant/manufacturer who shall bear all the risks of non-compliance that may potentially occur if measurement uncertainty is taken into account.
2. The measurement uncertainty please refer to each test result in the section "Measurement Uncertainty"

**Disclaimer:**

The product specifications of the EUT presented in the test report that may affect the test assessments are declared by the manufacturer who shall take full responsibility for the authenticity.



# 1 General Description

## 1.1 Applicant

Nokia Shanghai Bell Co., Ltd.

388#, Ningqiao Road, China (Shanghai) Pilot Free Trade Zone, Shanghai 201206, China

## 1.2 Manufacturer

Nokia Solutions and Networks Oy

Karakaari 7, 02610 Espoo, Finland

## 1.3 Feature of Equipment Under Test

Product Feature	
Equipment	Nokia FastMile 5G Gateway 12
Brand Name	Nokia
Model Name	5G31-03W-B
FCC ID	2ADZR5G3103WB
SN / IMEI Code	Conducted: KLT241102369(SN) Radiation: 355630740001412(IMEI)
HW Version	3TG03021Exxx (x may be from A to Z)
SW Version	5GGW-QCOM7X_D240200B31T0601E0496
EUT Stage	Identical Prototype

**Remark:** There are three samples under test, only different for the antenna manufacturers as below. According to the difference, we choose sample 1 to full test and the sample 2/3 are verified the RSE worse cases of LTE/NR in another report.

Ant Description	P/N	Vendor_1	Vendor_2	Vendor_3
Ant0&WiFi3_2.4G	3TG03393AAAA	GW12-A0W3	N42NKASA-PK1-D1X95BUD150U4LI	NKH049-15-000-R
Ant1&WiFi2_6G	3TG03394AAAA	GW12-A1W2	N40NKASB-PK1-E1X190BUE110U4LI	NKH050-15-000-R
Ant 2,Ant3,Ant5,Ant7	3TG03395AAAA	GW12-A2357	N40NKASC-PK1-R150U4LID115U4LI E165U4LIA105U4LI	NKH051-15-000-R
Ant4,Ant6&Ant9	3TG03396AAAA	GW12-A469	N40NKASD-PK1-A135U4LID170U4LI E200U4LI	NKH052-15-000-R
WiFi1_6G	3TG03397AAAA	GW12-W1	N06NKASF-PK1-A1X95BU	NKH053-15-000-R
WiFi4_2.4G	3TG03398AAAA	GW12-W4	N01NKASG-PK1-R1X160BU	NKH054-15-000-R
WiFi5_5G	3TG03399AAAA	GW12-W5	N02NKASH-PK1-D1X90BU	NKH055-15-000-R
Ant8&WiFi6_5G	3TG03400AAAA	GW12-A8W6	N43NKASE-PK1-E1X95BUA165U4LI	NKH056-15-000-R
WiFi7_5G	3TG03401AAAA	GW12-W7	N02NKASJ-PK1-A1X95BU	NKH057-15-000-R
WiFi8_5G	3TG03402AAAA	GW12-W8	N02NKASK-PK1-R1X115BU	NKH058-15-000-R



### 1.4 Product Specification of Equipment Under Test

Product Specification subjective to this standard	
Tx Frequency	814 ~ 824 MHz
Rx Frequency	859 ~ 869 MHz
SCS / Bandwidth	15kHz : 5MHz / 10MHz / 15MHz / 20MHz
Antenna Gain	<Ant. 0>: 2.40 dBi
Type of Modulation	CP-OFDM: QPSK / 16QAM / 64QAM / 256QAM DFT-s-OFDM: PI/2 BPSK / QPSK / 16QAM / 64QAM / 256QAM

Note: 5G NR n26 only support SA mode.

### 1.5 Modification of EUT

No modifications are made to the EUT during all test items.

### 1.6 Maximum Conducted Power and Emission Designator

5G NR n26		PI/2 BPSK / QPSK		16QAM / 64QAM / 256QAM	
BW (MHz)	Frequency Range (MHz)	Maximum Conducted power(W)	Emission Designator (99%OBW)	Maximum Conducted power(W)	Emission Designator (99%OBW)
5	816.5 ~ 821.5	0.2328	4M47G7D	0.1897	4M48W7D
10	819	0.2371	9M30G7D	0.1824	9M33W7D
15	821.5	0.2307	14M1G7D	0.1879	14M1W7D
20	824	0.2393	18M9G7D	0.1858	18M9W7D

### 1.7 Testing Site

Sporton International Inc. (Kunshan) is accredited to ISO/IEC 17025:2017 by American Association for Laboratory Accreditation with Certificate Number 5145.02.

Test Firm	Sporton International Inc. (Kunshan)		
Test Site Location	No. 1098, Pengxi North Road, Kunshan Economic Development Zone Jiangsu Province 215300 People's Republic of China TEL : +86-512-57900158		
Test Site No.	Sporton Site No.	FCC Designation No.	FCC Test Firm Registration No.
	03CH04-KS	CN1257	314309



Sporton International Inc. (ShenZhen) is accredited to ISO/IEC 17025:2017 by American Association for Laboratory Accreditation with Certificate Number 5145.01.

<b>Test Firm</b>	Sporton International Inc. (ShenZhen)		
<b>Test Site Location</b>	1/F, 2/F, Bldg 5, Shiling Industrial Zone, Xinwei Village, Xili, Nanshan, Shenzhen, 518055 People’s Republic of China TEL: +86-755-86379589 FAX: +86-755-86379595		
<b>Test Site No.</b>	<b>Sporton Site No.</b>	<b>FCC Designation No.</b>	<b>FCC Test Firm Registration No.</b>
	TH01-SZ	CN1256	421272

Note: Test data subcontracted: Test cases in section 3.1~3.4&3.6 of this report.

### 1.8 Test Software

Item	Site	Manufacturer	Name	Version
1.	03CH04-KS	AUDIX	E3	6.2009-8-24al

### 1.9 Applied Standards

According to the specifications of the manufacturer, the EUT must comply with the requirements of the following standards:

- 47 CFR Part 2, 90(S)
- ANSI C63.26-2015
- FCC KDB 971168 D01 Power Meas. License Digital Systems v03r01
- FCC KDB 971168 D02 Misc Rev Approv License Devices v02r01

**Remark:**

1. All test items were verified and recorded according to the standards and without any deviation during the test.
2. This EUT has also been tested and complied with the requirements of FCC Part 15, Subpart B, recorded in a separate test report.



## 2 Test Configuration of Equipment Under Test

### 2.1 Test Mode

During all testing, EUT is in link mode with base station emulator at maximum power level. The spurious emission measurements were carried out in semi-anechoic chamber with 3-meter test range, and EUT is rotated on three test planes to find out the worst emission.

Frequency range investigated for radiated emission is 30 MHz to 9000 MHz.

Test Items	Band	Bandwidth (MHz)				Modulation					RB #			Test Channel		
		5	10	15	20	PI/2 BPSK	QPSK	16QAM	64QAM	256QAM	1	Half	Full	L	M	H
Max. Output Power	n26	v	v	v	v	v	v	v	v	v	v		v	v	v	v
Peak to Average Ratio	n26				v	v	v				v		v		v	
26dB and 99% Bandwidth	n26	v	v	v	v		v	v	v	v			v		v	
Emission masks In-band emissions	n26	v				v	v				v		v	v		v
			v			v	v				v		v		v	
					v	v	v				v		v	v		
Emission masks – Out of band emissions	n26	v				v	v				v			v	v	v
			v			v	v				v				v	
					v	v	v				v			v		
Frequency Stability	n26				v		v						v	v		
Radiated Spurious Emission	n26	Worst Case													v	
Note	<ol style="list-style-type: none"> <li>The mark "v" means that this configuration is chosen for testing</li> <li>The mark "-" means that this bandwidth is not supported.</li> <li>5G n26 transmit frequency for part22 rule is 824MHz-849MHz, for part90 rule is 814MHz-824MHz. ERP over 15MHz bandwidth complies the ERP limit line of part22 rule, therefore ERP of the partial frequency spectrum which falls within part 22 also complies.</li> <li>Frequency Stability : Normal Voltage = 12V ; Low Voltage =10.8V ; High Voltage =13.2V;</li> </ol>															



## 2.2 Connection Diagram of Test System

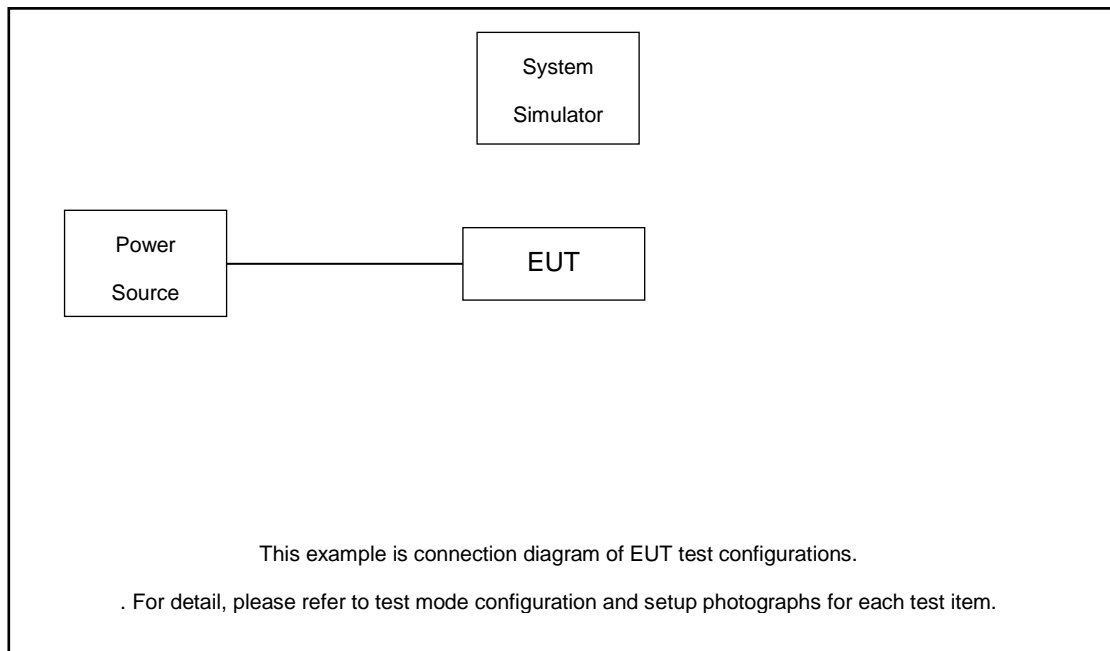

## 2.3 Support Unit used in test configuration and system

Item	Equipment	Trade Name	Model No.	FCC ID	Data Cable	Power Cord
1.	Power Supply	GWINSTEK	PSS-2002	N/A	N/A	Unshielded, 1.8 m
2.	NR Base Station	Anritsu	MT8000A	N/A	N/A	Unshielded, 1.8 m

## 2.4 Measurement Results Explanation Example

### For all conducted test items:

The offset level is set in the spectrum analyzer to compensate the RF cable loss between RF conducted output port and spectrum analyzer. With the offset compensation, the spectrum analyzer reading level will be exactly the RF output level.

The spectrum analyzer offset is derived from RF cable loss.

*Offset = RF cable loss.*

The following shows an offset computation example with RF cable loss 7.5dB.

Example :

$$\begin{aligned} \text{Offset(dB)} &= \text{RF cable loss(dB)}. \\ &= 7.5 \text{ (dB)} \end{aligned}$$



## 2.5 Frequency List of Low/Middle/High Channels

5G NR n26 Channel and Frequency List				
BW [MHz]	Channel/Frequency(MHz)	Lowest	Middle	Highest
10	Channel	-	163800	-
	Frequency	-	819	-
5	Channel	163300	163800	164300
	Frequency	816.5	819	821.5

5G NR n26 Cross-rule Channel and Frequency List				
BW [MHz]	Channel/Frequency(MHz)	-	Middle	-
20	Channel	-	164800	-
	Frequency	-	824	-
15	Channel	-	164300	-
	Frequency	-	821.5	-

### 3 Test Result

#### 3.1 Conducted Output Power Measurement

##### 3.1.1 Description of the Conducted Output Power Measurement

A system simulator was used to establish communication with the EUT. Its parameters were set to enforce EUT transmitting at the maximum power. The measured power in the radio frequency on the transmitter output terminals shall be reported.

##### 3.1.2 Measuring Instruments

The measuring equipment is listed in the section 4 of this test report.

##### 3.1.3 Test Procedures

1. The transmitter output port was connected to the system simulator.
2. Set EUT at maximum power through the system simulator.
3. Select lowest, middle, and highest channels for each band and different modulation.
4. Measure and record the power level from the system simulator.

##### 3.1.4 Test Setup

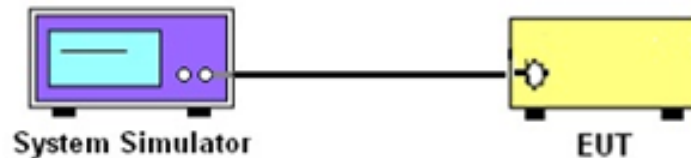

##### 3.1.5 Test Result of Conducted Output Power

Please refer to Appendix A.

## 3.2 99% Occupied Bandwidth and 26dB Bandwidth Measurement

### 3.2.1 Description of (Occupied) Bandwidth Limitations Measurement

The 99% occupied bandwidth is the width of a frequency band such that, below the lower and above the upper frequency limits, the mean powers emitted are each equal to a specified percentage 0.5% of the total mean transmitted power.

The emission bandwidth is defined as the width of the signal between two points, located at the 2 sides of the carrier frequency, outside of which all emissions are attenuated at least 26 dB below the transmitter power.

### 3.2.2 Measuring Instruments

The measuring equipment is listed in the section 4 of this test report.

### 3.2.3 Test Procedures

1. The EUT was connected to spectrum analyzer and system simulator via a power divider.
2. The 26dB and 99% occupied bandwidth (BW) of the middle channel for the highest RF power with full RB sizes were measured.

### 3.2.4 Test Setup

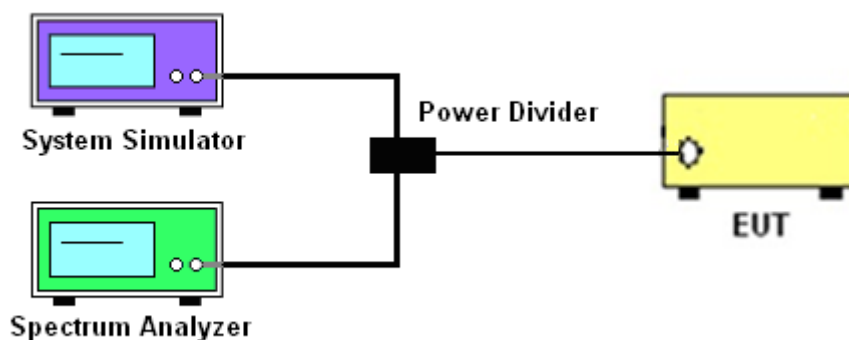

### 3.2.5 Test Result of 99% Occupied Bandwidth and 26dB Bandwidth

Please refer to Appendix A.



### 3.3 Emissions Mask Measurement

#### 3.3.1 Description of Emissions Mask Measurement

Equipment used in this licensed to EA or non-EA systems shall comply with the emission mask provisions of FCC Part 90.691.(a):

(a) Out-of-band emission requirement shall apply only to the “outer” channels included in an EA license and to spectrum adjacent to interior channels used by incumbent licensees. The emission limits are as follows:

(1) For any frequency removed from the EA licensee's frequency block by up to and including 37.5 kHz, the power of any emission shall be attenuated below the transmitter power (P) in watts by at least  $116 \text{ Log}_{10}(f/6.1)$  decibels or  $50 + 10 \text{ Log}_{10}(P)$  decibels or 80 decibels, whichever is the lesser attenuation, where f is the frequency removed from the center of the outer channel in the block in kilohertz and where f is greater than 12.5 kHz.

(2) For any frequency removed from the EA licensee's frequency block greater than 37.5 kHz, the power of any emission shall be attenuated below the transmitter power (P) in watts by at least  $43 + 10 \text{ Log}_{10}(P)$  decibels or 80 decibels, whichever is the lesser attenuation, where f is the frequency removed from the center of the outer channel in the block in kilohertz and where f is greater than 37.5 kHz.

#### 3.3.2 Measuring Instruments

The measuring equipment is listed in the section 4 of this test report.

#### 3.3.3 Test Procedures

1. The EUT was connected to spectrum analyzer and base station via power divider.
2. The emissions mask of low and high channels for the highest RF powers were measured.
3. The measured RBW and the VBW set 3 times of RBW are then set in spectrum analyzer, and the RBW correction factor  $10 \text{ log } (1\% \text{ of OBW/measured RBW})(\text{dB})$  was compensated, if required.
4. The test results were shown below plots with a correction offset factor including cable loss, insertion loss of power divider.

### 3.3.4 Test Setup

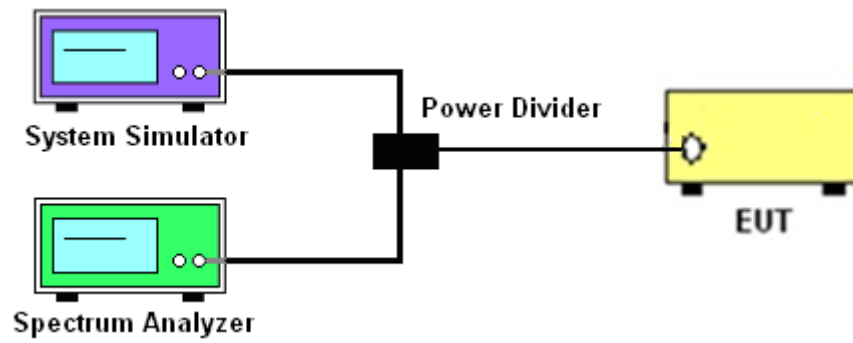

### 3.3.5 Test Result (Plots) of Conducted Emissions Mask

Please refer to Appendix A.

### 3.4 Emissions Mask – Out Of Band Emissions Measurement

#### 3.4.1 Description of Conducted Emissions Out of band emissions measurement

The power of any emission FCC Part 90.691 (a)(2) on any frequency removed from the assigned frequency by out of the authorized bandwidth at least  $43 + 10 \log (P)$  dB. It is measured by means of a calibrated spectrum analyzer and scanned from 30 MHz up to a frequency including its 10<sup>th</sup> harmonic.

#### 3.4.2 Measuring Instruments

The measuring equipment is listed in the section 4 of this test report.

#### 3.4.3 Test Procedures

1. The EUT was connected to spectrum analyzer and system simulator via a power divider.
2. The RF output of EUT was connected to the spectrum analyzer by RF cable and attenuator. The path loss was compensated to the results for each measurement.
3. The middle channel for the highest RF power within the transmitting frequency was measured.
4. The conducted spurious emission for the whole frequency range was taken.
5. Make the measurement with the spectrum analyzer's RBW = 1MHz, VBW = 3MHz, taking the record of maximum spurious emission.
6. The RF fundamental frequency should be excluded against the limit line in the operating frequency band.
7. The limit line is derived from  $43 + 10\log(P)$ dB below the transmitter power P(Watts)

#### 3.4.4 Test Setup

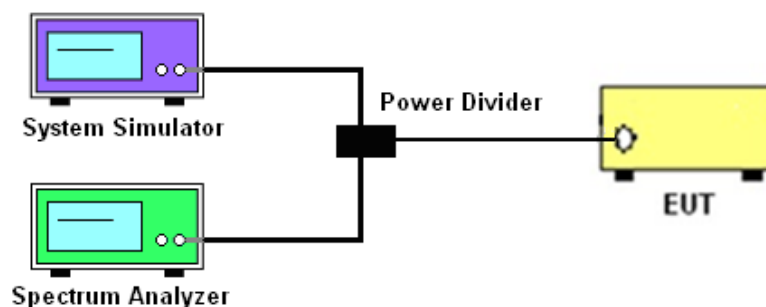

#### 3.4.5 Test Result (Plots) of Conducted Emission

Please refer to Appendix A.



### 3.5 Field Strength of Spurious Radiation Measurement

#### 3.5.1 Description of Field Strength of Spurious Radiated Measurement

The radiated spurious emission was measured by substitution method according to ANSI/TIA-603-E. The power of any emission FCC Part 90.691 on any frequency removed from the assigned frequency by more than 250 percent of the authorized bandwidth at least  $43 + 10 \log (P)$  dB. The spectrum is scanned from 30 MHz up to a frequency including its 10th harmonic.

The power of any emission outside of the authorized operating frequency ranges must be attenuated below the transmitter power (P) by a factor of at least  $43+10\log_{10}(P[\text{Watts}])$  dB. The spectrum is scanned from 30 MHz up to a frequency including its 10th harmonic.

#### 3.5.2 Measuring Instruments

The measuring equipment is listed in the section 4 of this test report.

#### 3.5.3 Test Procedures

1. The EUT was placed on a turntable with 0.8 meter for frequency below 1GHz and 1.5 meter for frequency above 1GHz respectively above ground.
2. The EUT was set 3 meters from the receiving antenna, which was mounted on the antenna tower.
3. The table was rotated 360 degrees to determine the position of the highest spurious emission.
4. The height of the receiving antenna is varied between one meter and four meters to search the maximum spurious emission for both horizontal and vertical polarizations.
5. Make the measurement with the spectrum analyzer's RBW = 1MHz, VBW = 3MHz, Sweep = 500ms, Taking the record of maximum spurious emission.
6. A horn antenna was substituted in place of the EUT and was driven by a signal generator.
7. Tune the output power of signal generator to the same emission level with EUT maximum spurious emission.
8. Taking the record of output power at antenna port.
9. Repeat step 7 to step 8 for another polarization.
10.  $EIRP \text{ (dBm)} = S.G. \text{ Power} - Tx \text{ Cable Loss} + Tx \text{ Antenna Gain}$
11.  $ERP \text{ (dBm)} = EIRP - 2.15$
12. The RF fundamental frequency should be excluded against the limit line in the operating frequency band.
13. The limit line is derived from  $43 + 10\log(P)$  dB below the transmitter power P(Watts)



### 3.5.4 Test Setup

For radiated test from 30MHz

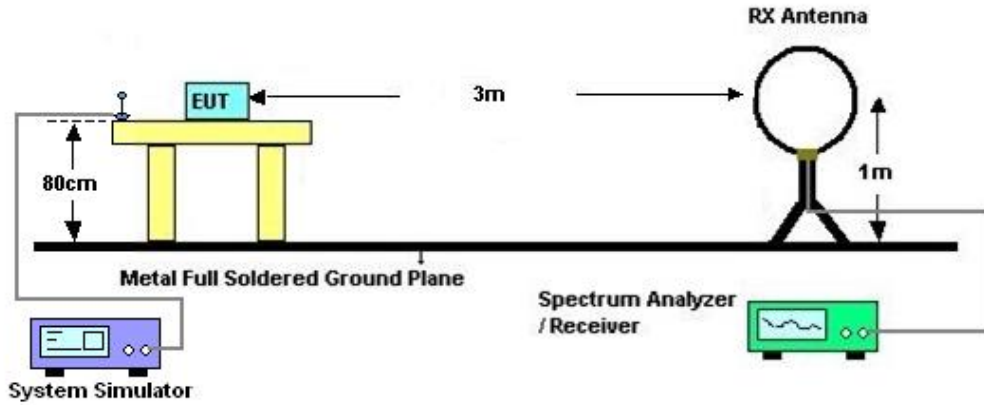

For radiated test from 30MHz to 1GHz

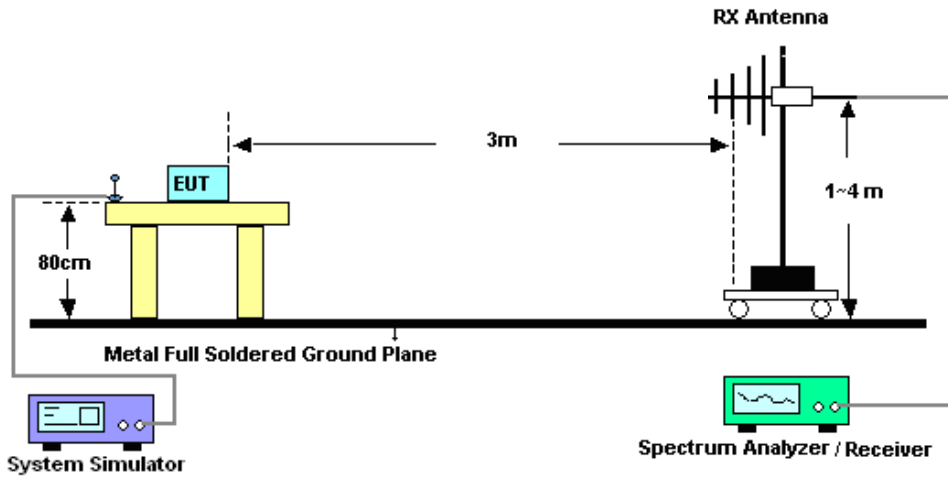

For radiated test above 1GHz

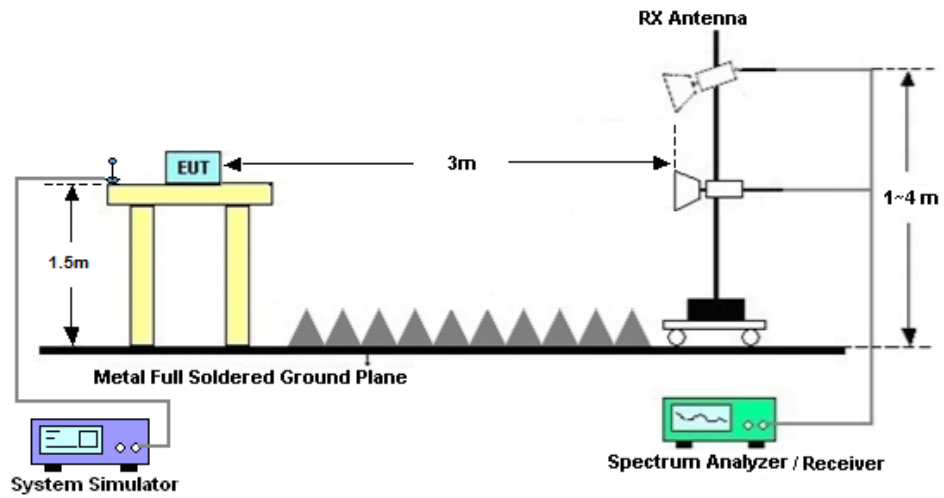

### 3.5.5 Test Result of Field Strength of Spurious Radiated

The low frequency, which started from 9 kHz to 30MHz, was pre-scanned and the result which was 20dB lower than the limit line was not reported.

Please refer to Appendix B.



## 3.6 Frequency Stability Measurement

### 3.6.1 Description of Frequency Stability Measurement

The frequency stability shall be measured by variation of ambient temperature and variation of primary supply voltage to ensure that the fundamental emission stays within the authorized frequency block. The frequency stability of the transmitter shall be maintained within  $\pm 0.00025\%$  ( $\pm 2.5\text{ppm}$ ) of the center frequency according to FCC Part 90.213.

### 3.6.2 Measuring Instruments

The measuring equipment is listed in the section 4 of this test report.

### 3.6.3 Test Procedures for Temperature Variation

1. The EUT was set up in the thermal chamber and connected with the base station.
2. With power OFF, the temperature was decreased to  $-30^{\circ}\text{C}$  and the EUT was stabilized for three hours. Power was applied and the maximum change in frequency was recorded within one minute.
3. With power OFF, the temperature was raised in  $10^{\circ}\text{C}$  step up to  $50^{\circ}\text{C}$ . The EUT was stabilized at each step for at least half an hour. Power was applied and the maximum frequency change was recorded within one minute.

### 3.6.4 Test Procedures for Voltage Variation

1. The EUT was placed in a temperature chamber at  $20\pm 5^{\circ}\text{C}$  and connected with the system simulator.
2. The power supply voltage to the EUT was varied from 85% to 115% of the nominal value for other than hand carried battery equipment.
3. For hand carried, battery powered equipment, reduce the primary ac or dc supply voltage to the battery operating end point, which shall be specified by the manufacturer.
4. The variation in frequency was measured for the worst case.

### 3.6.5 Test Setup

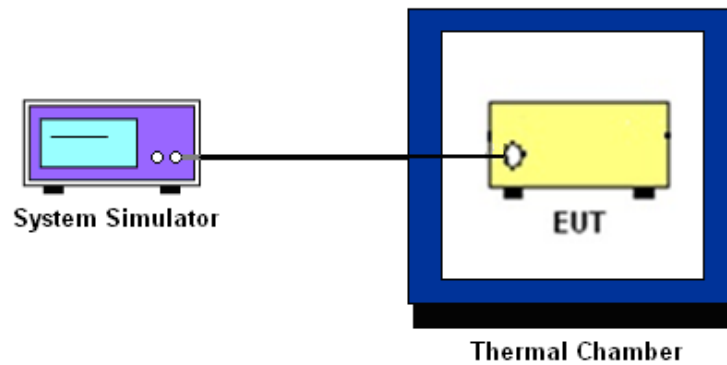

### 3.6.6 Test Result of Temperature Variation

Please refer to Appendix A.



## 4 List of Measuring Equipment

Instrument	Manufacturer	Model No.	Serial No.	Characteristics	Calibration Date	Test Date	Due Date	Remark
EXA Spectrum Analyzer	KEYSIGHT	N9010A	MY55150213	10Hz~44GHz	Jul. 07, 2023	Apr. 05, 2024~ Apr. 19, 2024	Jul. 06, 2024	Conducted (TH01-SZ)
Power Divider	TOJOIN	PS-2SM-04 265	60.06.020.007 7	0.4GHz~26.5GHz	Dec. 25, 2023	Apr. 05, 2024~ Apr. 19, 2024	Dec. 24, 2024	Conducted (TH01-SZ)
Thermal Chamber	Ten Billion Hongzhangroup	LP-150U	H2014081803	-40~+150°C	Jul. 05, 2023	Apr. 05, 2024~ Apr. 19, 2024	Jul. 04, 2024	Conducted (TH01-SZ)
EXA Spectrum Analyzer	Keysight	N9010B	MY57471079	10Hz-44G,MAX 30dB	Oct. 10, 2023	May 09, 2024	Oct. 09, 2024	Radiation (03CH04-KS)
Loop Antenna	R&S	HFH2-Z2E	101125	9kHz~30MHz	Sep. 11, 2023	May 09, 2024	Sep. 10, 2024	Radiation (03CH04-KS)
Bilog Antenna	TeseQ	CBL6111D	59913	30MHz-1GHz	Aug. 19, 2023	May 09, 2024	Aug. 18, 2024	Radiation (03CH04-KS)
Double Ridge Horn Antenna	ETS-Lindgren	3117	00251694	1GHz~18GHz	Jul. 12, 2023	May 09, 2024	Jul. 11, 2024	Radiation (03CH04-KS)
Amplifier	SONOMA	310N	380827	9KHz-1GHz	Jul. 06, 2023	May 09, 2024	Jul. 05, 2024	Radiation (03CH04-KS)
high gain Amplifier	EM	EM01G18G A	060840	1Ghz-18Ghz	Oct. 10, 2023	May 09, 2024	Oct. 09, 2024	Radiation (03CH04-KS)
Amplifier	Agilent	8449B	3008A02370	1Ghz-18Ghz	Oct. 10, 2023	May 09, 2024	Oct. 09, 2024	Radiation (03CH04-KS)
AC Power Source	Chroma	61601	F104090004	N/A	NCR	May 09, 2024	NCR	Radiation (03CH04-KS)
Turn Table	ChamPro	EM 1000-T	060762-T	0~360 degree	NCR	May 09, 2024	NCR	Radiation (03CH04-KS)
Antenna Mast	ChamPro	EM 1000-A	060762-A	1 m~4 m	NCR	May 09, 2024	NCR	Radiation (03CH04-KS)

NCR: No Calibration Required



## 5 Measurement Uncertainty

The measurement uncertainties shown below were calculated in accordance with the requirements of ANSI 63.26-2015. All the measurement uncertainty value were shown with a coverage K=2 to indicate 95% level of confidence. The measurement data show herein meets or exceeds the CISPR measurement uncertainty values specified in CISPR 16-4-2 and can be compared directly to specified limit to determine compliance.

### Uncertainty of Conducted Measurement

Test Item	Uncertainty
Conducted Spurious Emission & Bandedge	±1.34 dB
Occupied Channel Bandwidth	±0.012 MHz
Conducted Power	±1.34 dB
Frequency Stability	±1.3 Hz

### Uncertainty of Radiated Emission Measurement (30 MHz ~ 1000 MHz)

Measuring Uncertainty for a Level of Confidence of 95% (U = 2Uc(y))	2.83 dB
---	---------

### Uncertainty of Radiated Emission Measurement (1 GHz ~ 18 GHz)

Measuring Uncertainty for a Level of Confidence of 95% (U = 2Uc(y))	2.83 dB
---	---------

----- THE END -----



## Appendix A. Test Results of Conducted Test

Test Engineer :	Khan Zheng	Temperature :	21~23°C
		Relative Humidity :	45~51%

# FR1 N26(ANT0)

## Transmitter Conducted Output Power

NR Band	SCS (kHz)	Bandwidth (MHz)	Arfcn	Freq (MHz)	Modulation	RB	Conducted Power(dBm)
26	15	5	163300	816.5	DFT-s-OFDM QPSK	1@1	23.65
26	15	5	163300	816.5	DFT-s-OFDM 16 QAM	1@1	22.68
26	15	5	163800	819	DFT-s-OFDM QPSK	1@1	23.67
26	15	5	163800	819	DFT-s-OFDM 16 QAM	1@1	22.78
26	15	5	164300	821.5	DFT-s-OFDM QPSK	1@1	23.56
26	15	5	164300	821.5	DFT-s-OFDM 16 QAM	1@1	22.63
26	15	10	163800	819	DFT-s-OFDM QPSK	1@1	23.75
26	15	10	163800	819	DFT-s-OFDM 16 QAM	1@1	22.61
26	15	15	164300	821.5	DFT-s-OFDM QPSK	1@1	23.63
26	15	15	164300	821.5	DFT-s-OFDM 16 QAM	1@1	22.74
26	15	20	164800	824	DFT-s-OFDM PI/2 BPSK	50@25	23.79
26	15	20	164800	824	DFT-s-OFDM PI/2 BPSK	1@1	23.68
26	15	20	164800	824	DFT-s-OFDM PI/2 BPSK	1@104	23.5
26	15	20	164800	824	DFT-s-OFDM QPSK	50@25	23.69
26	15	20	164800	824	DFT-s-OFDM QPSK	1@1	23.67
26	15	20	164800	824	DFT-s-OFDM QPSK	1@104	23.36
26	15	20	164800	824	DFT-s-OFDM 16 QAM	50@25	22.69
26	15	20	164800	824	DFT-s-OFDM 16 QAM	1@1	22.63
26	15	20	164800	824	DFT-s-OFDM 16 QAM	1@104	22.51
26	15	20	164800	824	DFT-s-OFDM 64 QAM	50@25	21.18
26	15	20	164800	824	DFT-s-OFDM 64 QAM	1@1	21.36
26	15	20	164800	824	DFT-s-OFDM 64 QAM	1@104	20.99
26	15	20	164800	824	DFT-s-OFDM 256 QAM	50@25	19.33
26	15	20	164800	824	DFT-s-OFDM 256 QAM	1@1	19.47
26	15	20	164800	824	DFT-s-OFDM 256 QAM	1@104	19.02
26	15	20	164800	824	CP-OFDM QPSK	53@26	22.11
26	15	20	164800	824	CP-OFDM QPSK	1@1	22.26
26	15	20	164800	824	CP-OFDM QPSK	1@104	21.79



## Frequency Stability

NR Band	SCS (kHz)	Bandwidth (MHz)	Arfcn	Freq (MHz)	Modulation	RB	Deviation (ppm)	Verdict	Environment
26	15	20	164800	824.0	DFT-s-OFDM QPSK	100@0	0.0032	<b>PASS</b>	NV
26	15	20	164800	824.0	DFT-s-OFDM QPSK	100@0	0.0034	<b>PASS</b>	LV
26	15	20	164800	824.0	DFT-s-OFDM QPSK	100@0	0.0043	<b>PASS</b>	HV
26	15	20	164800	824.0	DFT-s-OFDM QPSK	100@0	0.0062	<b>PASS</b>	-30°C
26	15	20	164800	824.0	DFT-s-OFDM QPSK	100@0	0.0039	<b>PASS</b>	-20°C
26	15	20	164800	824.0	DFT-s-OFDM QPSK	100@0	0.0054	<b>PASS</b>	-10°C
26	15	20	164800	824.0	DFT-s-OFDM QPSK	100@0	0.0041	<b>PASS</b>	0°C
26	15	20	164800	824.0	DFT-s-OFDM QPSK	100@0	0.0041	<b>PASS</b>	10°C
26	15	20	164800	824.0	DFT-s-OFDM QPSK	100@0	0.0032	<b>PASS</b>	20°C
26	15	20	164800	824.0	DFT-s-OFDM QPSK	100@0	0.0023	<b>PASS</b>	30°C
26	15	20	164800	824.0	DFT-s-OFDM QPSK	100@0	0.0046	<b>PASS</b>	40°C
26	15	20	164800	824.0	DFT-s-OFDM QPSK	100@0	0.0027	<b>PASS</b>	50°C

# Peak to Average Ratio

NR Band	SCS (kHz)	Bandwidth (MHz)	Arfcn	Freq (MHz)	Modulation	RB	Result (dB)	Limit (dB)	Verdict
26	15	20	164800	824.0	DFT-s-OFDM PI/2 BPSK	100@0	3.89	13	PASS
26	15	20	164800	824.0	DFT-s-OFDM QPSK	100@0	4.52	13	PASS

N26(20M)\_DFT-s-OFDM\_PI\_2-BPSK\_Outer\_Full\_Mid\_CH



N26(20M)\_DFT-s-OFDM\_QPSK\_Outer\_Full\_Mid\_CH

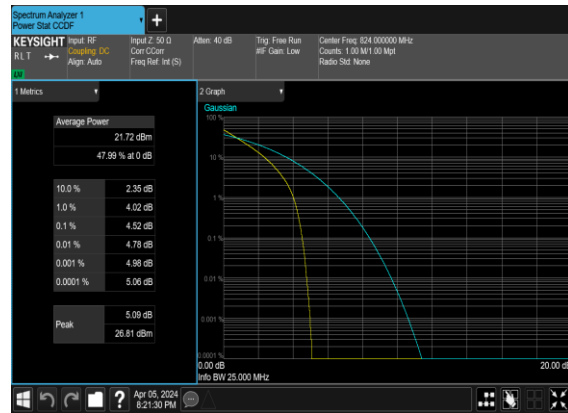

## Occupied Bandwidth

NR Band	SCS (kHz)	Bandwidth (MHz)	Arfcn	Freq (MHz)	Modulation	RB	OBW (MHz)	26dB BW (MHz)
26	15	5	163800	819.0	CP-OFDM QPSK	25@0	4.4711	5.102
26	15	5	163800	819.0	CP-OFDM 16 QAM	25@0	4.4826	5.12
26	15	5	163800	819.0	CP-OFDM 64 QAM	25@0	4.4745	5.04
26	15	5	163800	819.0	CP-OFDM 256 QAM	25@0	4.4804	5.071
26	15	10	163800	819.0	CP-OFDM QPSK	52@0	9.3044	10.11
26	15	10	163800	819.0	CP-OFDM 16 QAM	52@0	9.3018	10.03
26	15	10	163800	819.0	CP-OFDM 64 QAM	52@0	9.2881	10.03
26	15	10	163800	819.0	CP-OFDM 256 QAM	52@0	9.325	9.979
26	15	15	164300	821.5	CP-OFDM QPSK	79@0	14.112	14.89
26	15	15	164300	821.5	CP-OFDM 16 QAM	79@0	14.1	14.92
26	15	15	164300	821.5	CP-OFDM 64 QAM	79@0	14.132	14.88
26	15	15	164300	821.5	CP-OFDM 256 QAM	79@0	14.107	14.91
26	15	20	164800	824.0	CP-OFDM QPSK	106@0	18.882	19.79
26	15	20	164800	824.0	CP-OFDM 16 QAM	106@0	18.901	19.84
26	15	20	164800	824.0	CP-OFDM 64 QAM	106@0	18.887	19.85
26	15	20	164800	824.0	CP-OFDM 256 QAM	106@0	18.887	19.8

### N26(5M)\_CP-OFDM\_QPSK\_Outer\_Full\_Mid\_CH



### N26(5M)\_CP-OFDM\_16QAM\_Outer\_Full\_Mid\_CH

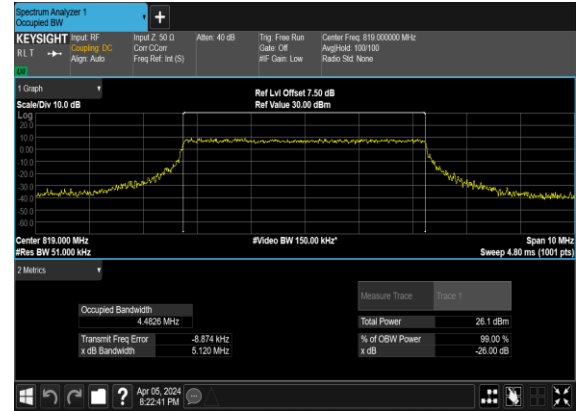

### N26(5M)\_CP-OFDM\_64QAM\_Outer\_Full\_Mid\_CH

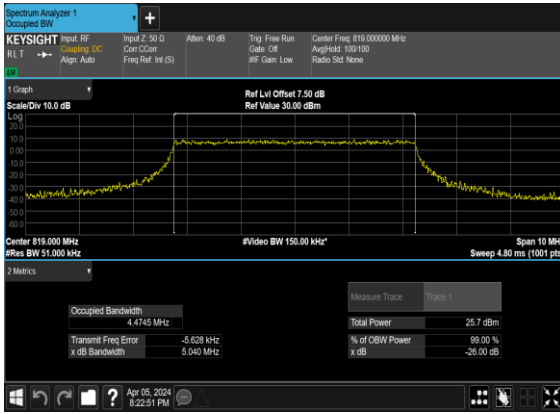

### N26(5M)\_CP-OFDM\_256QAM\_Outer\_Full\_Mid\_CH

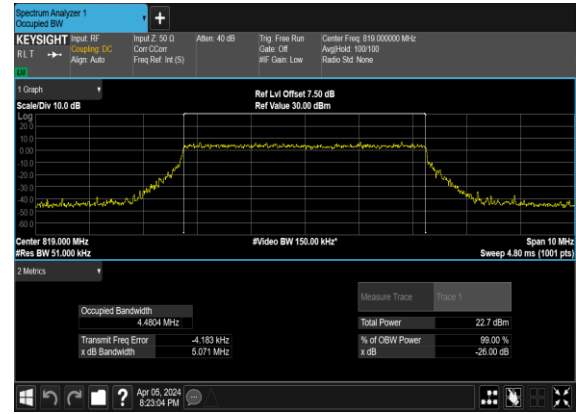

### N26(10M)\_CP-OFDM\_QPSK\_Outer\_Full\_Mid\_CH

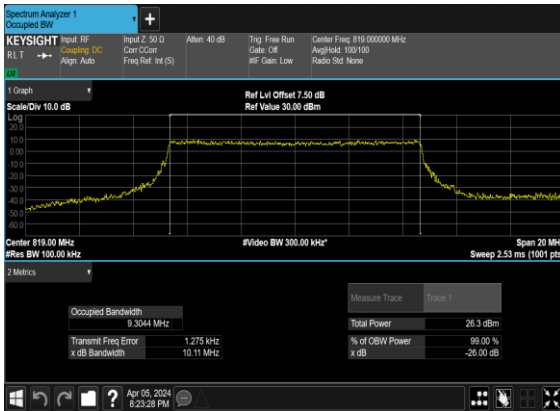

### N26(10M)\_CP-OFDM\_16QAM\_Outer\_Full\_Mid\_CH

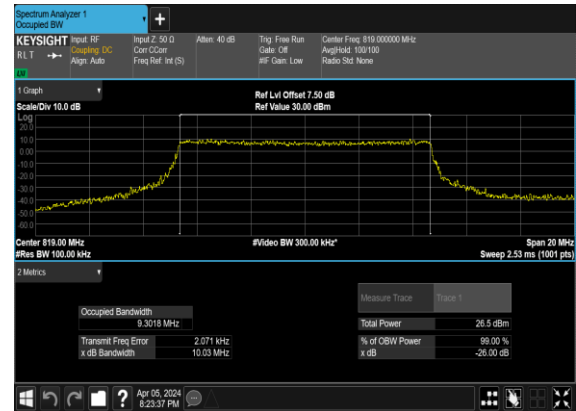

### N26(10M)\_CP-OFDM\_64 QAM\_Outer\_Full\_Mid\_CH

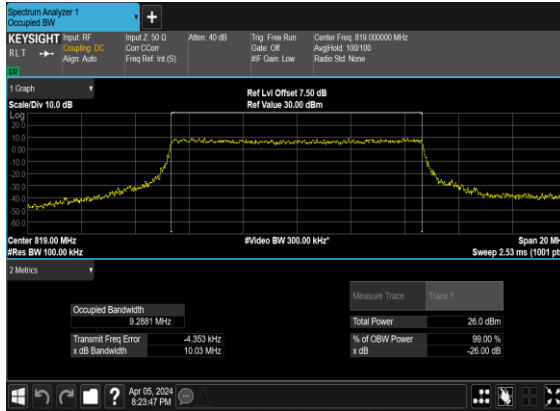

### N26(10M)\_CP-OFDM\_256 QAM\_Outer\_Full\_Mid\_CH

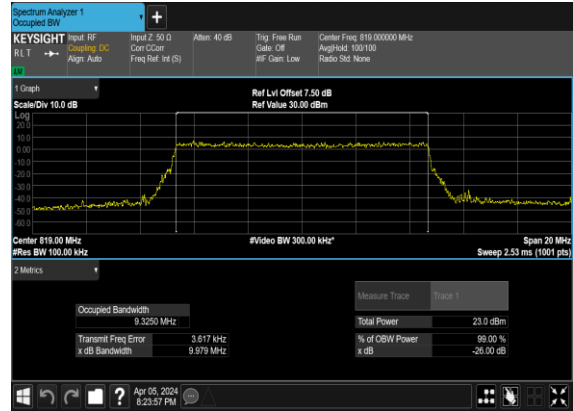

### N26(15M)\_CP- OFDM\_QPSK\_Outer\_Full\_Mid\_CH



### N26(15M)\_CP-OFDM\_16 QAM\_Outer\_Full\_Mid\_CH



### N26(15M)\_CP-OFDM\_64 QAM\_Outer\_Full\_Mid\_CH

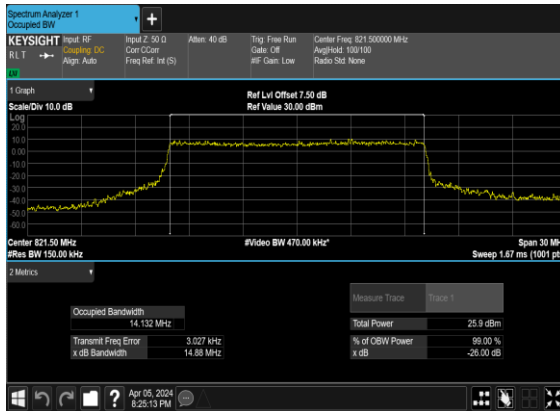

### N26(15M)\_CP-OFDM\_256 QAM\_Outer\_Full\_Mid\_CH

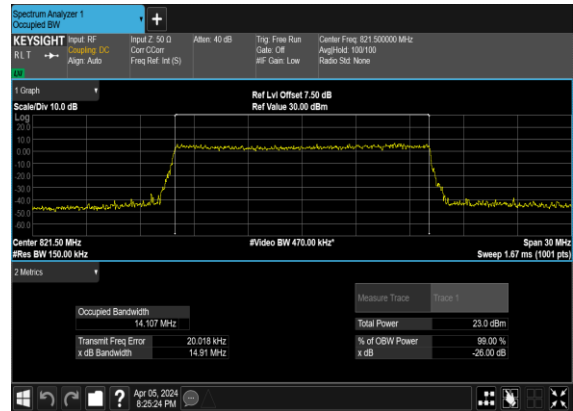

### N26(20M)\_CP-OFDM\_QPSK\_Outer\_Full\_Mid\_CH

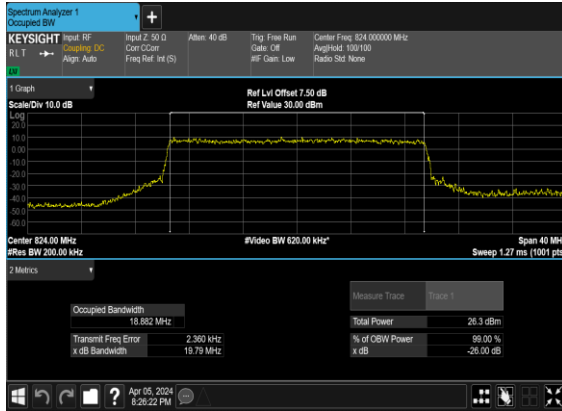

### N26(20M)\_CP-OFDM\_16QAM\_Outer\_Full\_Mid\_CH

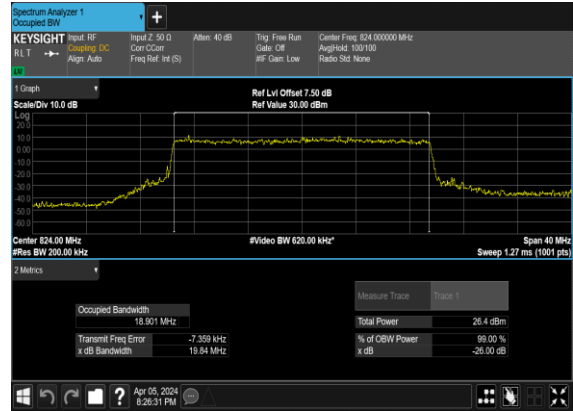

### N26(20M)\_CP-OFDM\_64QAM\_Outer\_Full\_Mid\_CH

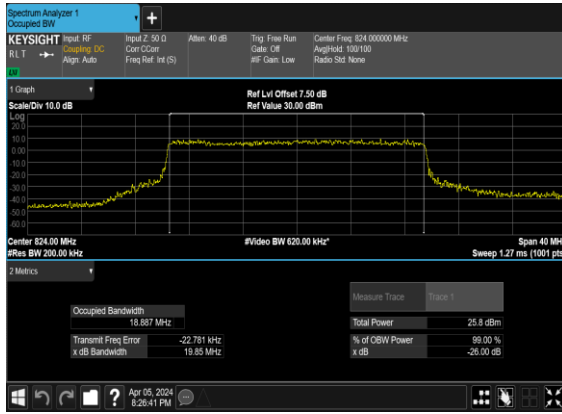

### N26(20M)\_CP-OFDM\_256QAM\_Outer\_Full\_Mid\_CH

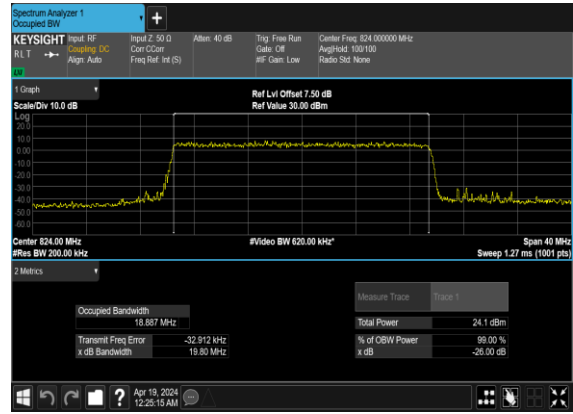

## Conducted Spurious Emissions

NR Band	SCS (kHz)	Bandwidth (MHz)	Arfcn	Freq (MHz)	Modulation	RB	Result	Verdict
26	15	5	163300	816.5	DFT-s-OFDM BPSK	1@0	see graph	---
26	15	5	163300	816.5	DFT-s-OFDM BPSK	1@0	see graph	<b>PASS</b>
26	15	5	163300	816.5	DFT-s-OFDM QPSK	1@0	see graph	---
26	15	5	163300	816.5	DFT-s-OFDM QPSK	1@0	see graph	<b>PASS</b>
26	15	5	163800	819.0	DFT-s-OFDM BPSK	1@0	see graph	---
26	15	5	163800	819.0	DFT-s-OFDM BPSK	1@0	see graph	<b>PASS</b>
26	15	5	163800	819.0	DFT-s-OFDM QPSK	1@0	see graph	---
26	15	5	163800	819.0	DFT-s-OFDM QPSK	1@0	see graph	<b>PASS</b>
26	15	5	164300	821.5	DFT-s-OFDM BPSK	1@0	see graph	---
26	15	5	164300	821.5	DFT-s-OFDM BPSK	1@0	see graph	<b>PASS</b>
26	15	5	164300	821.5	DFT-s-OFDM QPSK	1@0	see graph	---
26	15	5	164300	821.5	DFT-s-OFDM QPSK	1@0	see graph	<b>PASS</b>
26	15	10	163800	819.0	DFT-s-OFDM BPSK	1@0	see graph	---
26	15	10	163800	819.0	DFT-s-OFDM BPSK	1@0	see graph	<b>PASS</b>
26	15	10	163800	819.0	DFT-s-OFDM QPSK	1@0	see graph	---
26	15	10	163800	819.0	DFT-s-OFDM QPSK	1@0	see graph	<b>PASS</b>
26	15	20	164800	824.0	DFT-s-OFDM BPSK	1@0	see graph	---
26	15	20	164800	824.0	DFT-s-OFDM BPSK	1@0	see graph	<b>PASS</b>
26	15	20	164800	824.0	DFT-s-OFDM QPSK	1@0	see graph	---
26	15	20	164800	824.0	DFT-s-OFDM QPSK	1@0	see graph	<b>PASS</b>

### N26(5M)\_DFT-s-OFDM\_BPSK\_Edge\_1RB\_Left\_Low\_CH



### N26(5M)\_DFT-s-OFDM\_QPSK\_Edge\_1RB\_Left\_Low\_CH

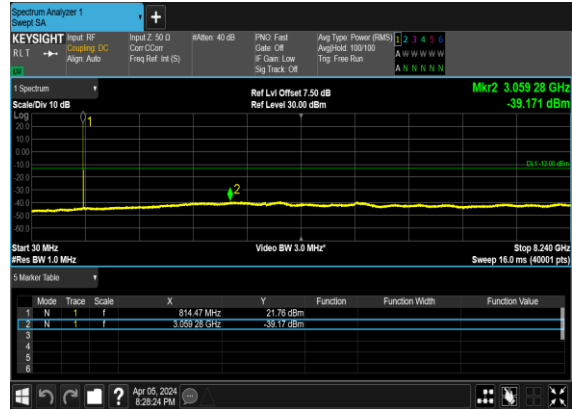

### N26(5M)\_DFT-s-OFDM\_BPSK\_Edge\_1RB\_Left\_Mid\_CH

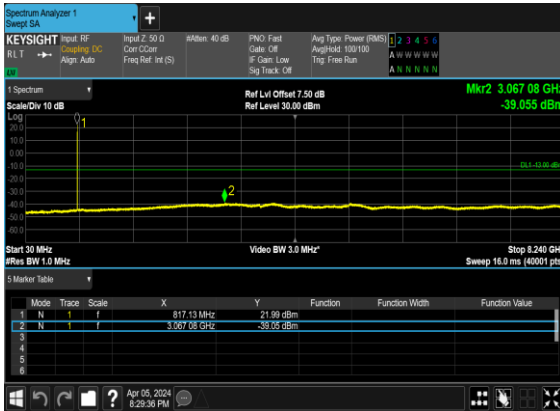

### N26(5M)\_DFT-s-OFDM\_QPSK\_Edge\_1RB\_Left\_Mid\_CH



### N26(5M)\_DFT-s-OFDM\_BPSK\_Edge\_1RB\_Left\_High\_CH

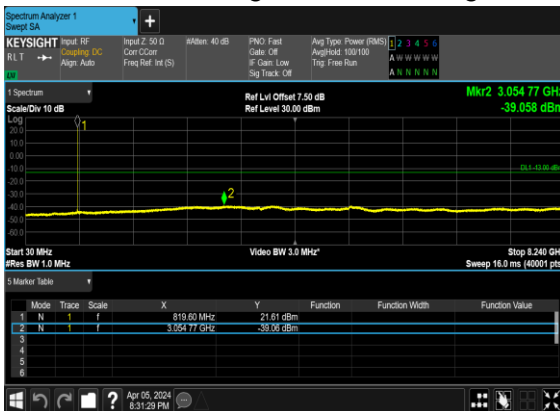

### N26(5M)\_DFT-s-OFDM\_QPSK\_Edge\_1RB\_Left\_High\_CH

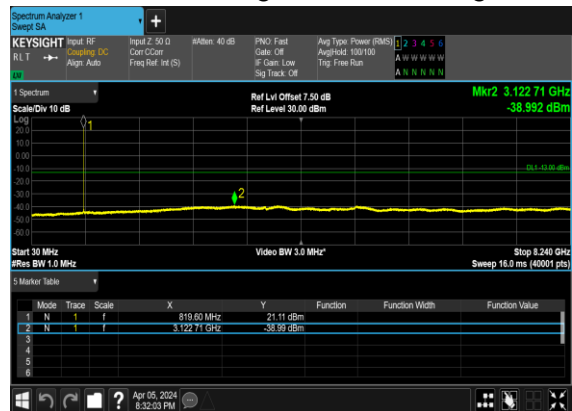



### N26(10M)\_DFT-s-OFDM\_BPSK\_Edge\_1RB\_Left\_Mid\_CH



### N26(10M)\_DFT-s-OFDM\_QPSK\_Edge\_1RB\_Left\_Mid\_CH

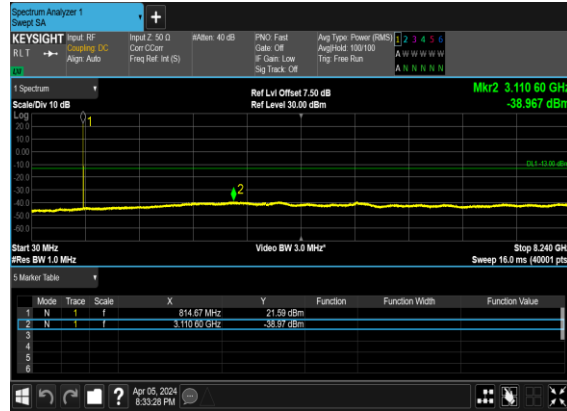

### N26(20M)\_DFT-s-OFDM\_BPSK\_Edge\_1RB\_Left\_Mid\_CH

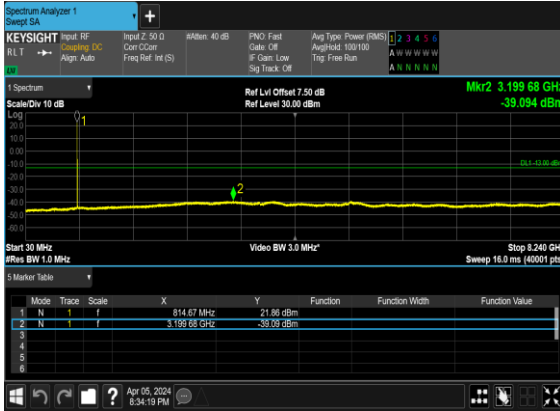

### N26(20M)\_DFT-s-OFDM\_QPSK\_Edge\_1RB\_Left\_Mid\_CH



## Conducted Band Edge

NR Band	SCS (kHz)	Bandwidth (MHz)	Arfcn	Freq (MHz)	Modulation	RB	Result	Verdict
26	15	5	163300	816.5	DFT-s-OFDM BPSK	1@0	see graph	PASS
26	15	5	163300	816.5	DFT-s-OFDM QPSK	1@0	see graph	PASS
26	15	5	163300	816.5	DFT-s-OFDM BPSK	25@0	see graph	PASS
26	15	5	163300	816.5	DFT-s-OFDM QPSK	25@0	see graph	PASS
26	15	5	164300	821.5	DFT-s-OFDM BPSK	1@24	see graph	PASS
26	15	5	164300	821.5	DFT-s-OFDM QPSK	1@24	see graph	PASS
26	15	5	164300	821.5	DFT-s-OFDM BPSK	25@0	see graph	PASS
26	15	5	164300	821.5	DFT-s-OFDM QPSK	25@0	see graph	PASS
26	15	10	163800	819.0	DFT-s-OFDM BPSK	1@0	see graph	PASS
26	15	10	163800	819.0	DFT-s-OFDM QPSK	1@0	see graph	PASS
26	15	10	163800	819.0	DFT-s-OFDM BPSK	1@51	see graph	PASS
26	15	10	163800	819.0	DFT-s-OFDM QPSK	1@51	see graph	PASS
26	15	10	163800	819.0	DFT-s-OFDM BPSK	50@0	see graph	PASS
26	15	10	163800	819.0	DFT-s-OFDM QPSK	50@0	see graph	PASS
26	15	20	164800	824.0	DFT-s-OFDM BPSK	1@0	see graph	PASS
26	15	20	164800	824.0	DFT-s-OFDM QPSK	1@0	see graph	PASS
26	15	20	164800	824.0	DFT-s-OFDM BPSK	1@105	see graph	PASS
26	15	20	164800	824.0	DFT-s-OFDM QPSK	1@105	see graph	PASS
26	15	20	164800	824.0	DFT-s-OFDM BPSK	100@0	see graph	PASS
26	15	20	164800	824.0	DFT-s-OFDM QPSK	100@0	see graph	PASS

N26(5M)\_DFT-s-OFDM\_BPSK\_Edge\_1RB\_Left\_Low\_CH

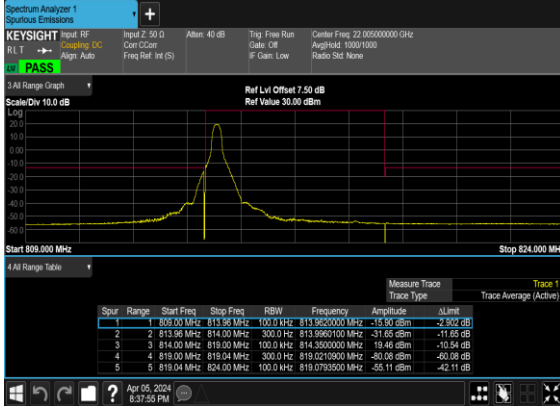

N26(5M)\_DFT-s-OFDM\_BPSK\_Edge\_1RB\_Left\_Low\_CH\_CHP\_PASS

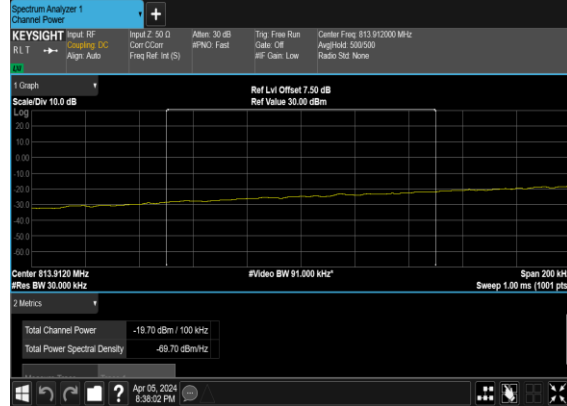

N26(5M)\_DFT-s-OFDM\_QPSK\_Edge\_1RB\_Left\_Low\_CH

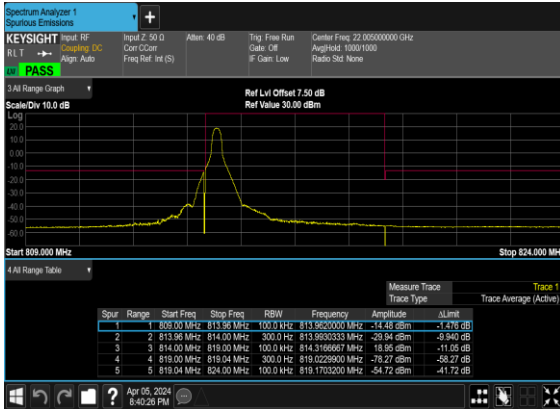

N26(5M)\_DFT-s-OFDM\_QPSK\_Edge\_1RB\_Left\_Low\_CH\_CHP\_PASS

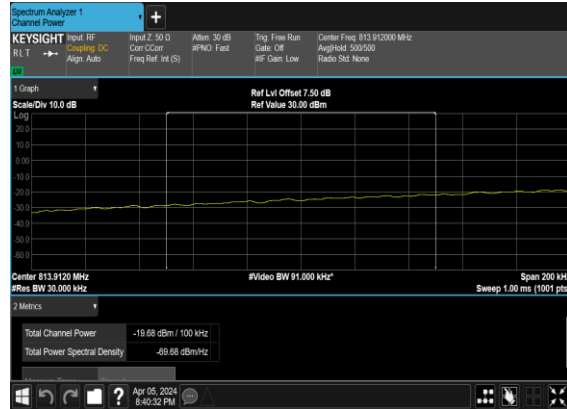

N26(5M)\_DFT-s-OFDM\_BPSK\_Outer\_Full\_Low\_CH

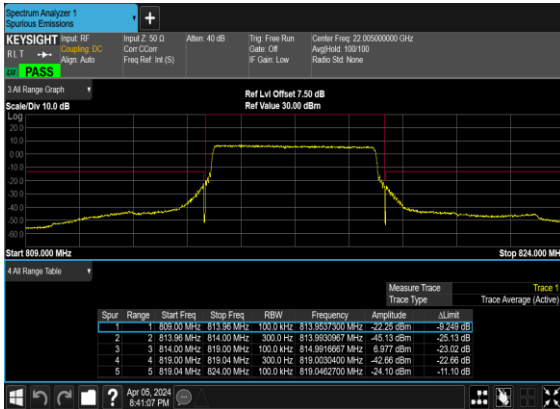

N26(5M)\_DFT-s-OFDM\_QPSK\_Outer\_Full\_Low\_CH

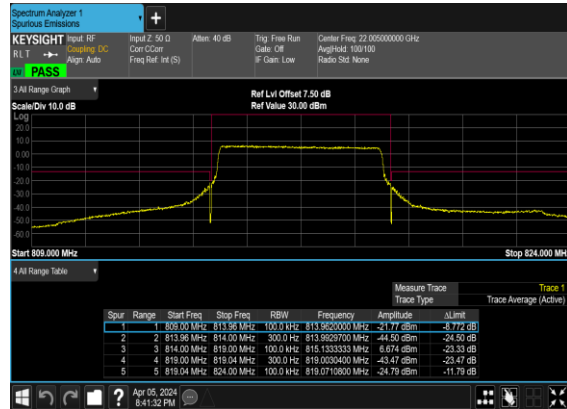

N26(5M)\_DFT-s-OFDM\_BPSK\_Edge\_1RB\_Right\_High\_CH

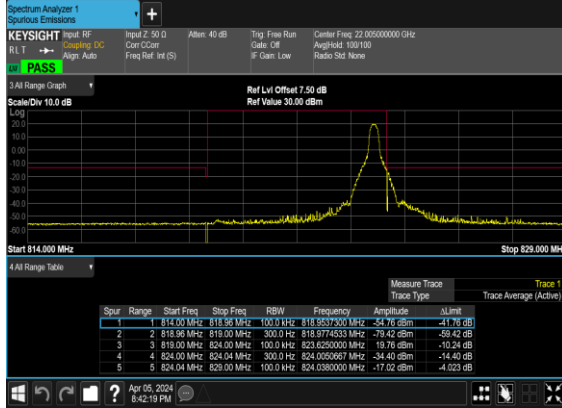

N26(5M)\_DFT-s-OFDM\_QPSK\_Edge\_1RB\_Right\_High\_CH

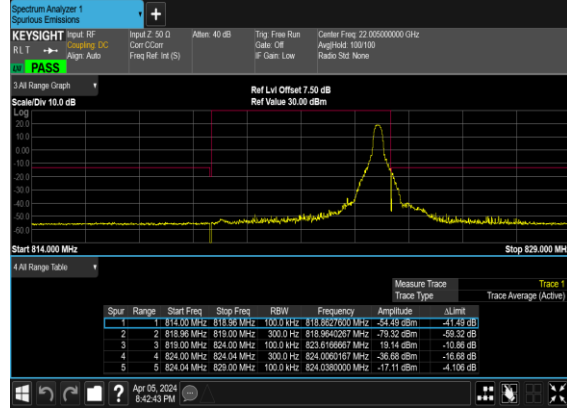

N26(5M)\_DFT-s-OFDM\_BPSK\_Outer\_Full\_High\_CH

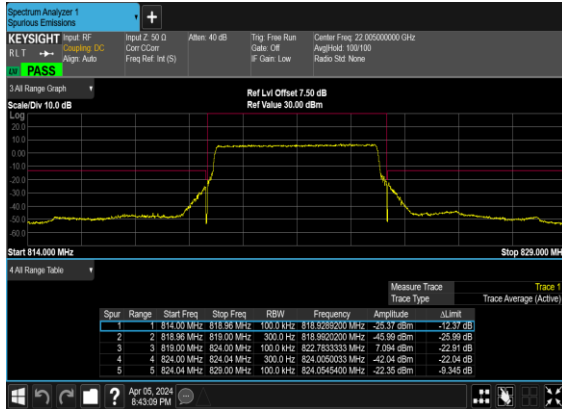

N26(5M)\_DFT-s-OFDM\_QPSK\_Outer\_Full\_High\_CH

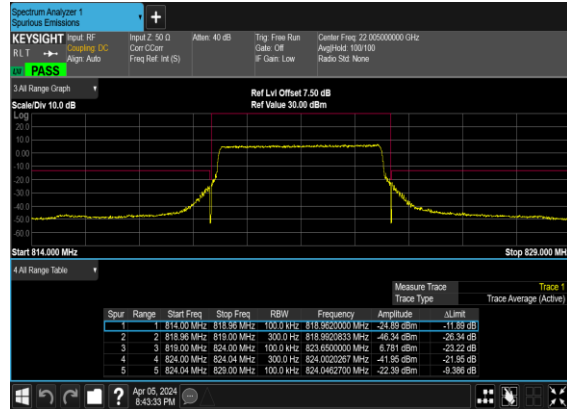

N26(10M)\_DFT-s-OFDM\_BPSK\_Edge\_1RB\_Left\_Mid\_CH

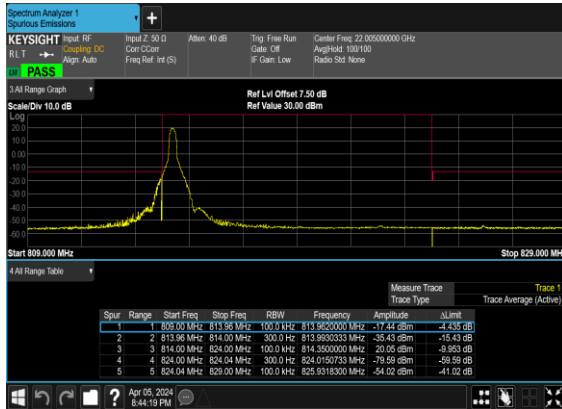

N26(10M)\_DFT-s-OFDM\_QPSK\_Edge\_1RB\_Left\_Mid\_CH

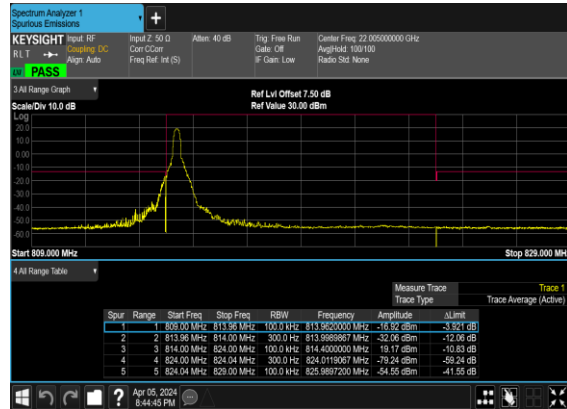

### N26(10M)\_DFT-s- OFDM\_BPSK\_Edge\_1RB\_Right\_Mid\_CH

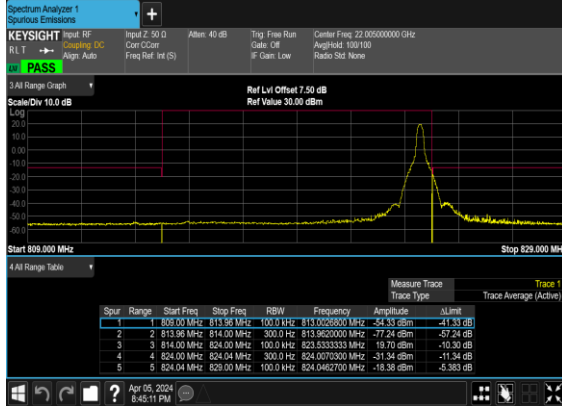

### N26(10M)\_DFT-s- OFDM\_QPSK\_Edge\_1RB\_Right\_Mid\_CH

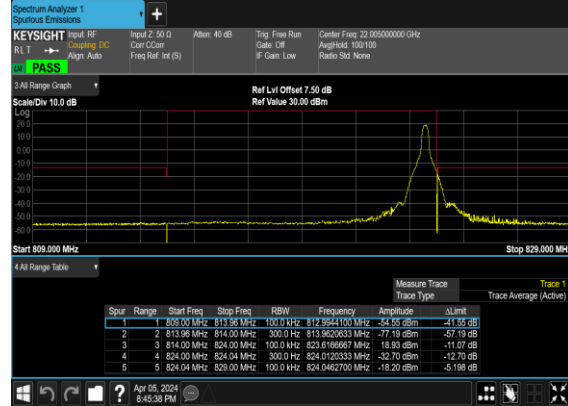

### N26(10M)\_DFT-s- OFDM\_BPSK\_Outer\_Full\_Mid\_CH

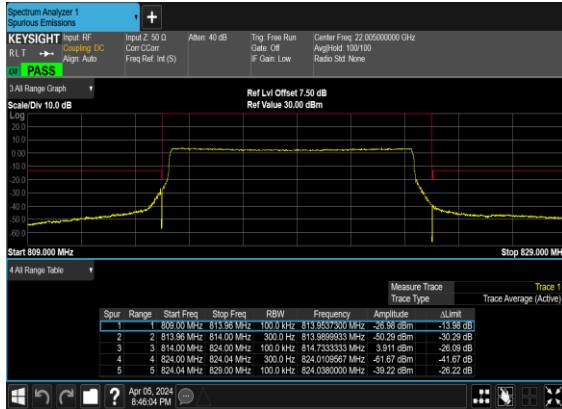

### N26(10M)\_DFT-s- OFDM\_QPSK\_Outer\_Full\_Mid\_CH

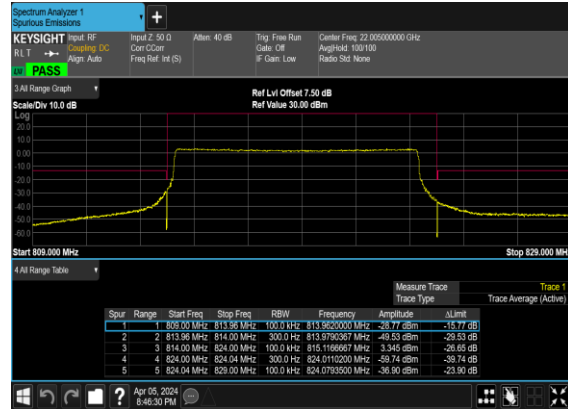

### N26(20M)\_DFT-s- OFDM\_BPSK\_Edge\_1RB\_Left\_Mid\_CH

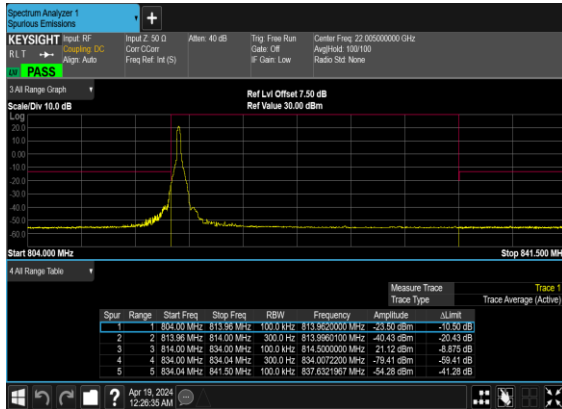

### N26(20M)\_DFT-s- OFDM\_QPSK\_Edge\_1RB\_Left\_Mid\_CH

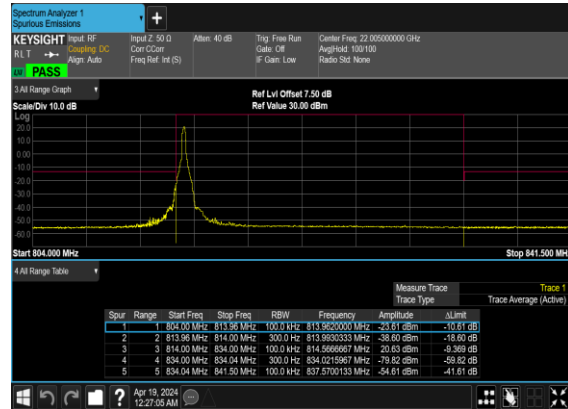

### N26(20M)\_DFT-s- OFDM\_BPSK\_Edge\_1RB\_Right\_Mid\_CH

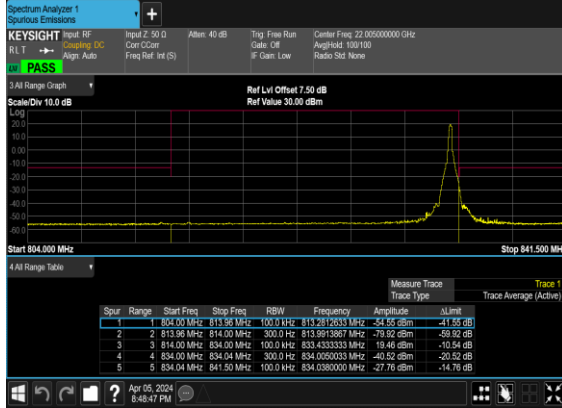

### N26(20M)\_DFT-s- OFDM\_QPSK\_Edge\_1RB\_Right\_Mid\_CH

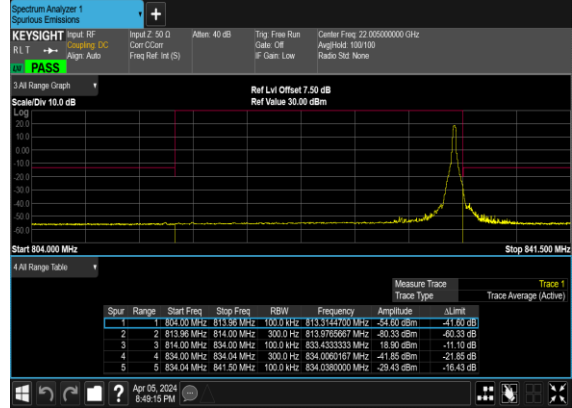

### N26(20M)\_DFT-s- OFDM\_BPSK\_Outer\_Full\_Mid\_CH

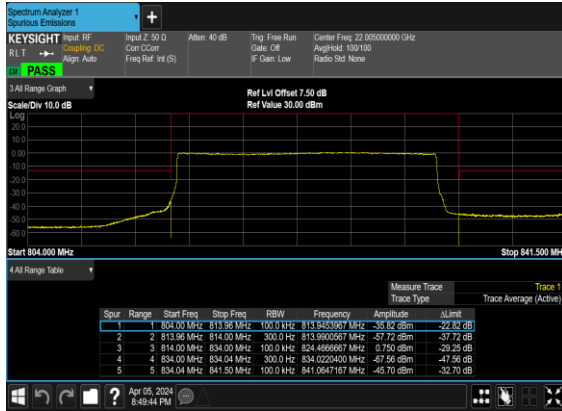

### N26(20M)\_DFT-s- OFDM\_QPSK\_Outer\_Full\_Mid\_CH

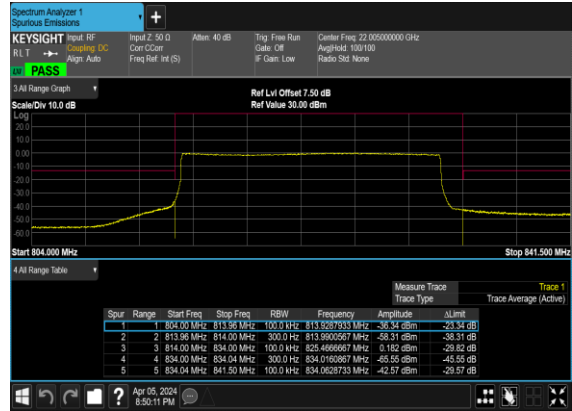



## Appendix B. Test Results of Radiated Test

### Radiated Spurious Emission

Test Engineer :	Carl Ni	Temperature :	23~25°C
		Relative Humidity :	41~42%

n26 SA / NR 20MHz / QPSK / Ant.0								
Channel	Frequency ( MHz )	ERP ( dBm )	Limit ( dBm )	Over Limit ( dB )	S.G. Power ( dBm )	TX Cable loss ( dB )	TX Antenna Gain (dBi)	Polarization (H/V)
Middle	1632	-65.87	-13	-52.87	-72.84	1.58	10.70	H
	2448	-61.51	-13	-48.51	-69.76	2.102	12.50	H
	3264	-60.27	-13	-47.27	-69.16	2.856	13.90	H
	1632	-65.13	-13	-52.13	-72.10	1.58	10.70	V
	2448	-59.58	-13	-46.58	-67.83	2.10	12.50	V
	3264	-60.13	-13	-47.13	-69.02	2.86	13.90	V

Remark: Spurious emissions within 30-1000MHz were found more than 20dB below limit line.