





# Test Report

**Product name** ..... : WIRELESS VIDEO TRANSMISSION SYSTEM  
**Trademark** ..... :  **HOLLYLAND**  
**Model no.**..... : Pyro H  
**Series Model(s)**..... : /  
**FCC ID** ..... : 2ADZC-9830T  
**IC ID** ..... : 29803-9830T  
**Report No** ..... : C231222039-RF11  
**Test Standards**..... : CFR47 FCC Part 15: Subpart E Section 15.407  
CFR47 FCC Part 15: Subpart C Section 15.207  
CFR47 FCC Part 15: Subpart C Section 15.209  
RSS-247 Issue 3  
RSS-Gen Issue 5  
**Applicant**..... : Shenzhen Hollyland Technology Co., Ltd  
**Address of applicant** ..... : 8F, Building 5D, Skyworth Innovation Valley, Tangtou  
Road,Shiyan Street, Baoan District Shenzhen, China  
**Manufacturer**..... : Shenzhen Hollyland Technology Co., Ltd  
**Manufacturer Address**..... : 8F, Building 5D, Skyworth Innovation Valley, Tangtou  
Road,Shiyan Street, Baoan District Shenzhen, China  
**Date of Test Date**..... : Dec 22, 2023 to Mar 06, 2024  
**Date of issue**..... : Mar 06, 2024  
**Test result**..... : Compliance

**Testing Engineer** :   
\_\_\_\_\_  
Jeff Fang  
**Reviewed By** :   
\_\_\_\_\_  
Adil Yang  
**Approved Signatory** :   
\_\_\_\_\_  
Tom Gan

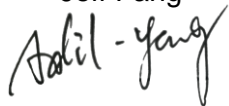
The test results in the report only apply to the tested sample. The test report shall be invalid without all the signatures of testing engineers, reviewer and approver. Any objections must be raised to CSIC within 15 days since the date when the report is received. It will not be taken into consideration beyond this limit.

Revision History

Rev.	Issue Date	Revisions	Effect Page	Revised By
00	Mar.06, 2024	Initial Issue	ALL	Adil Yang

**Table of Contents**

	<b>Page</b>
<b>1. TEST SUMMARY</b> .....	<b>4</b>
1.1. TEST DESCRIPTION .....	4
1.2. TEST FACILITY .....	5
1.3. MEASUREMENT UNCERTAINTY .....	5
<b>2. GENERAL INFORMATION</b> .....	<b>6</b>
2.1. GENERAL DESCRIPTION OF EUT .....	6
2.2. DESCRIPTION OF TEST MODES AND TEST FREQUENCY .....	7
2.3. MEASUREMENT INSTRUMENTS LIST .....	8
2.4. DESCRIPTION OF THE TEST MODES.....	10
2.5. TEST SOFTWARE AND POWER LEVEL .....	11
2.6. BLOCK DIGRAM SHOWING THE CONFIGURATION OF SYSTEM TESTED .....	11
2.7. DESCRIPTION OF NECESSARY ACCESSORIES AND SUPPORT UNITS .....	12
2.8. ENVIRONMENTAL CONDITIONS FOR TESTING .....	12
<b>3. EMC TEST</b> .....	<b>13</b>
3.1. CONDUCTED EMISSION ON AC MAINS MEASUREMENT .....	13
3.2. RADIATED SPURIOUS EMISSION MEASUREMENT.....	15
3.3. MAXIMUM CONDUCTED OUTPUT POWER MEASUREMENT.....	21
3.4. CONDUCTED POWER SPECTRAL DENSITY MEASUREMENT .....	23
3.5. 6dB BANDWIDTH MEASUREMENT .....	24
3.6. 26dB BANDWIDTH MEASUREMENT .....	25
3.7. 99% BANDWIDTH MEASUREMENT .....	26
3.8. FREQUENCY STABILITY MEASUREMENT .....	27
3.9. DYNAMIC FREQUENCY SELECTION (DFS) MEASUREMENT.....	28
3.10. ANTENNA REQUIREMENT .....	32
<b>4. TEST PHOTOS</b> .....	<b>33</b>
<b>5. EUT PHOTOS</b> .....	<b>34</b>

# 1. TEST SUMMARY

## 1.1. TEST DESCRIPTION

Test procedures according to the technical standards:

Item	Clause	Result	Note
Conducted Emission on AC Mains	Part 15.207(a) RSS-GEN clause 8.8	PASS	
Radiated Spurious Emission	Part 15.407(b) Part 15.205 Part 15.209 RSS-247 clause 6.2 RSS-GEN clause 8.9 RSS-GEN clause 8.10	PASS	
Maximum Conducted Output Power	Part 15.407(a) RSS-247 clause 6.2	PASS	
Conducted Power Spectral Density	Part 15.407(a) RSS-247 clause 6.2	PASS	
6dB Bandwidth	Part 15.407(e) RSS-247 clause 6.2	PASS	
26dB Bandwidth	Part 15.407(e) RSS-Gen Clause 6.6	PASS	
99% Bandwidth	Part 15.407(a) RSS-Gen Clause 6.6	PASS	
Frequency Stability	Part 15.407(g) RSS-Gen Clause 6.11	PASS	
Dynamic Frequency Selection (DFS)	Part 15.407(h) RSS-247 clause 6.3	N/A	
Antenna Requirement	Part 15.407(b)(4) Part 15.203	PASS	

Note:

- 1) "N/A" denotes test is not applicable in this Test Report.
- 2) All tests are according to ANSI C63.10-2013.
- 3) The statements of test result on the above are decided by the request of test standard only; the measurement uncertainties are not factored into this compliance determination.
- 4) The information of measurement uncertainty is available upon the customer's request.

## 1.2. TEST FACILITY

Shenzhen Central Standard International Center Co., Ltd. (CSIC)

Room 201, Building 1, Mogen Fashion Industrial Park, No. 10, Shilongzai Road, Xinshi Community, Dalang Street, Longhua District, Shenzhen.

The test facility is recognized, certified or accredited by the following organizations:

CNAS      Registration No.: L11671  
 FCC        Registration No.: 0031378433      Designation Number: CN1317  
 IC         CAB identifier: CN0051  
 A2LA      Lab Cert. No.: 6426.01

## 1.3. MEASUREMENT UNCERTAINTY

The estimated combined standard uncertainty for radiated emissions and conducted emissions measurements as below table.

Below is the best measurement capability for Shenzhen Central Standard International Center Co., Ltd.

Test Items	Measurement Uncertainty	Notes
RF output power, conducted	$\pm 0.59\text{dB}$	(1)
Unwanted Emissions, conducted	$\pm 2.20\text{dB}$	(1)
All emissions, radiated 9KHz-30MHz	$\pm 4.44\text{dB}$	(1)
All emissions, radiated 30-1GHz	$\pm 4.48\text{dB}$	(1)
All emissions, radiated 1G-6GHz	$\pm 5.08\text{dB}$	(1)
All emissions, radiated >6G	$\pm 5.08\text{dB}$	(1)
Conducted Emission (9KHz-150KHz)	$\pm 1.60\text{dB}$	(1)
Conducted Emission (150KHz-30MHz)	$\pm 3.68\text{dB}$	(1)

**Note(1):** This uncertainty represents an expanded uncertainty expressed at approximately the 95% confidence level using a coverage factor of  $k=2$ .

## 2. GENERAL INFORMATION

### 2.1. GENERAL DESCRIPTION OF EUT

EUT(Product Specifications)			
Product Name:	WIRELESS VIDEO TRANSMISSION SYSTEM		
Trademark:			
Model No.:	Pyro H		
Series Models:	/		
Power supply:	Adapter	Product Name:	SWITCHING ADAPTER
		Product Model:	GQ24-I20200-AX
		Product Spec.:	INPUT : 100-240Vac 50/60Hz 1.0A OUTPUT : DC 12.0V 2.0A 24.0W
		Manufacturer:	Dong Guan City GangQi Electronic Co., Ltd.
	Battery	Product Name:	Li-ion
		Product Spec.:	DC 7.4V 4000mAh 29.6Wh
	Type-C	Input: DC 5V 2A Output: DC 5V 2A	
Hardware version:	V18		
Software version:	V1.0.2.1		
WIFI-5G (RF Specifications)			
Operating Frequency	5150-5250MHz, 5725-5850MHz		
Channel number:	For 802.11ac(VHT20): 9 For 802.11ac(VHT40): 4		
Channel Spacing	20MHz, 40MHz		
Modulation	OFDM (BPSK, QPSK, 16QAM, 64QAM,256QAM)		
Antenna Type	EXTERNAL ANTENNA		
Antenna Gain	ANT1/2: 2.34 dBi for 5150MHz-5250MHz; 3.14 dBi for 5725MHz-5850MHz		

**Note:**

1. For a more detailed features description, please refer to the manufacture's specifications or the user's manual.
2. Full tests were applied to model C231222039-Y01/01 only in this document.
3. The product also supports battery power supply (the manufacturer claims that batteries are optional accessories during the sales process, and the final product standard does not include batteries). The power supply of this product adopts the principle of high-voltage optimization, and there is no battery charging circuit in the product. Therefore, a dedicated charger is required for battery charging. The battery power supply method has been evaluated and tested, but this document only reflects the data of the worst power supply method (adapter power supply).

## 2.2. DESCRIPTION OF TEST MODES AND TEST FREQUENCY

The EUT has been tested under typical operating condition. The Applicant provides communication tools software to control the EUT for staying in continuous transmitting mode for testing.

Operation Frequency List for WIFI:

Channel List for 802.11ac20							
Channel	Frequency (MHz)	Channel	Frequency (MHz)	Channel	Frequency (MHz)	Channel	Frequency (MHz)
<b>36</b>	<b>5180</b>	<b>40</b>	<b>5200</b>	44	5220	<b>48</b>	<b>5240</b>
52	5260	56	5280	60	5300	64	5320
100	5500	104	5520	108	5540	112	5560
116	5580	120	5600	124	5620	128	5640
132	5660	136	5680	140	5700	<b>149</b>	<b>5745</b>
153	5765	<b>157</b>	<b>5785</b>	159	5795	<b>165</b>	<b>5825</b>

Channel List for 802.11ac40							
Channel	Frequency (MHz)	Channel	Frequency (MHz)	Channel	Frequency (MHz)	Channel	Frequency (MHz)
<b>38</b>	<b>5190</b>	<b>46</b>	<b>5230</b>	54	5270	62	5310
102	5510	110	5550	118	5590	126	5630
134	5670	<b>151</b>	<b>5755</b>	<b>159</b>	<b>5795</b>		

### 2.3. MEASUREMENT INSTRUMENTS LIST

RF Connected Test					
Item	Test Equipment	Manufacturer	Model No.	Serial No.	Calibrated until
1	Spectrum Analyzer	Agilent	N9020A	MY50200391	May. 31, 2024
2	Spectrum Analyzer	R&S	FSV40	1632339B	Mar. 13, 2024
3	Power sensor	KEYSIGHT	U2021XA	MY55080015	May. 31, 2024
4	Power sensor	KEYSIGHT	U2021XA	MY54250016	May. 31, 2024
5	Power sensor	KEYSIGHT	U2021XA	MY54250020	May. 31, 2024
6	Power sensor	KEYSIGHT	U2021XA	MY54210030	May. 31, 2024
7	Vector Signal Generator	Agilent	N5182A	MY50140130	May. 31, 2024
8	Signal generator	Agilent	SML03	100925	May. 31, 2024
9	Temperature Humidity Chamber	GZ-ESPEC	ER-10AGT	0005091-2	May. 31, 2024
10	EXTENDED RANGE DC POWER SUPPLY	TAKASAGO	ZX-400LA	N/A	May. 31, 2024
11	Inverter power supply	AKE	AKE-2003-P2	N/A	May. 31, 2024
12	Power sensor Box	MWRFTest	N/A	N/A	N/A
13	RF Switch Box	MWRFTest	MW100-RFCB	N/A	N/A
14	MTS 8310	MWRFTest	V: 2.0.0.0		

Radiation Test equipment					
Item	Test Equipment	Manufacturer	Model No.	Serial No.	Calibrated until
1	EMI TEST RECEIVER	R&S	ESIB26	100342	May. 31, 2024
2	Spectrum Analyzer	R&S	FSV40	1632339B	Mar. 13, 2024
3	Amplifier	HP	8447F	2634A02050	May. 31, 2024
4	Amplifier	Agilent	8449B	4035A00116	May. 31, 2024
5	Amplifier	COM-MW	DPA8-1000-18000-1012	8220837	Mar. 19, 2024
6	Loop Antenna	SCHNARZBECK	FMZB1519B	00023	Nov. 12, 2025
7	Bilog Antenna	Schwarzbeck	VULB-9168	VULB9168-250	Jul. 25, 2025
8	Horn Antenna	AARONIAAG	Powerlog 70180	3980	Jul. 04, 2025
9	Horn Antenna	A-INFOMW	LB-180400-KF	J211020657	Sep. 25, 2024
10	3M Chamber	Maor	9*6*6	--	Mar. 01, 2026
11	EZ-EMC	Farad	V3.1		



Mains Terminal Disturbance Voltage Test equipment					
Item	Test Equipment	Manufacturer	Model No.	Serial No.	Calibrated until
1	EMI Test Receiver	R&S	ESRP3	101936	May. 31, 2024
2	LISN	R&S	ENV216	100002	May. 31, 2024
3	LISN	MEB	NNB 42	--	May. 31, 2024
4	Shelding Room	Maor	8*4*3	--	Mar. 01, 2025
8	EZ-EMC	Fara	V3.1		

Note:

- 1) The cable loss has calculated in test result which connection between each test instruments.

## 2.4. DESCRIPTION OF THE TEST MODES

To investigate the maximum EMI emission characteristics generates from EUT, the test system was pre-scanning tested base on the consideration of following EUT operation mode or test configuration mode which possible have effect on EMI emission level. Each of these EUT operation mode(s) or test configuration mode(s) mentioned above was evaluated respectively.

Worst Mode	Description	Data Rate
Mode 1	TX IEEE 802.11ac VHT20 CH36&CH40&CH48	6.5 Mbps
Mode 2	TX IEEE 802.11ac VHT20 CH149&CH157&CH165	6.5 Mbps
Mode 3	TX IEEE 802.11ac VHT40 CH38&CH46	13.5 Mbps
Mode 4	TX IEEE 802.11ac VHT40 CH151&CH159	13.5 Mbps

Note:

- 1) The measurements are performed at the high, middle, low available channels.
- 2) All the bit rate of transmitter have been tested and found the lowest rate is found to be the worst case and recorded.
- 3) This test was performed with EUT in X, Y, Z position and worst case was found when EUT in X position.
- 4) For radiated emission above 1 GHz test, 1GHz-40GHz have been pre-tested and in this report only recorded the worst case. The remaining spurious points are all below the limit value of 20dB.

For AC Conducted Emission

Test Case	
AC Conducted Emission	Mode5: Working

## 2.5. TEST SOFTWARE AND POWER LEVEL

During testing channel & power controlling software provided by the customer was used to control the operating channel as well as the output power level.

RF Function	Type	Mode Or Modulation type	Ant Gain(dBi)	Power Setting	Software For Testing
WIFI(5G)	5G WIFI	802.11ac(VHT20)	2.34 dBi for 5150MHz-5250MHz; 3.14 dBi for 5725MHz-5850MHz	40 for 5150MHz-5250MHz; 60 for 5725MHz-5850MHz	Secure CRT V7.0.4 <sup>Note</sup>
		802.11ac(VHT40)		60	

Note: Configure the test parameters from the command.

## 2.6. BLOCK DIGRAM SHOWING THE CONFIGURATION OF SYSTEM TESTED

### a. Radiated Spurious Emission Test

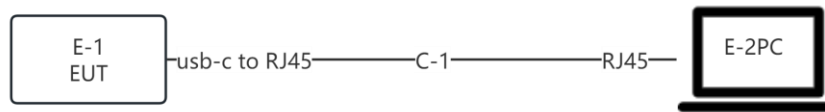

### b. Conducted Emission Test

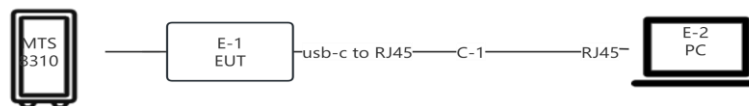

## 2.7. DESCRIPTION OF NECESSARY ACCESSORIES AND SUPPORT UNITS

The EUT has been tested as an independent unit together with other necessary accessories or support units. The following support units or accessories were used to form a representative test configuration during the tests.

Necessary accessories					
Item	Equipment	Mfr/Brand	Model/Type No.	Serial No.	Note
N/A	N/A	N/A	N/A	N/A	N/A

Support units					
Item	Equipment	Mfr/Brand	Model/Type No.	Serial No.	Note
E-2	Notebook	DELL	Vostro 3400	N/A	N/A
E-3	Router	GL iNet	GL-MT3000	N/A	N/A
C-1	RJ45 Cable	N/A	100cm	N/A	N/A

Note:

- 1) The support equipment was authorized by Declaration of Confirmation.
- 2) For detachable type I/O cable should be specified the length in cm in 『Length』 column.
- 3) The Router FCC ID: 2AFIW-MT3000; IC ID: 23019-MT3000.

## 2.8. ENVIRONMENTAL CONDITIONS FOR TESTING

Test Item	Temperature (°C)	Relative Humidity (%)	Test Voltage	Tested by
Conducted Emission on AC Mains	24.2	60.0	AC 120V/60Hz	Jeff Fang
Radiated Spurious Emission	24.5	53.0	AC 120V/60Hz	Jeff Fang
Conducted Spurious Emissions Measured in 100 kHz Bandwidth	22.1	58.0	AC 120V/60Hz	Jeff Fang
Conducted Power Spectral Density	22.1	58.0	AC 120V/60Hz	Jeff Fang
99% Bandwidth	22.1	58.0	AC 120V/60Hz	Jeff Fang
6dB Bandwidth	22.1	58.0	AC 120V/60Hz	Jeff Fang
Maximum Conducted Output Power	22.1	58.0	AC 120V/60Hz	Jeff Fang

### 3. EMC TEST

#### 3.1. Conducted Emission on AC Mains Measurement

##### Limit

Operating frequency band. In case the emission fall within the restricted band specified on Part 207(a) and RSS-Gen 8.8 limit in the table below has to be followed.

FREQUENCY (MHz)	Conducted Emission limit (dBuV)	
	Quasi-peak	Average
0.15 - 0.5	66 - 56 *	56 - 46 *
0.5 - 5	56	46
5 - 30	60	50

Note:

- 1) The tighter limit applies at the band edges.
- 2) The limit of “ \* ” marked band means the limitation decreases linearly with the logarithm of the frequency in the range.

The following table is the setting of the receiver

Receiver Parameters	Setting
Attenuation	10 dB
Start Frequency	0.15 MHz
Stop Frequency	30 MHz
RBW	9 kHz

##### Test Procedure

- a) The EUT was 0.8 meters from the horizontal ground plane and 0.4 meters from the vertical ground plane with EUT being connected to the power mains through a line impedance stabilization network (LISN). All other support equipment's powered from additional LISN(s). The LISN provide 50 Ohm/ 50uH of coupling impedance for the measuring instrument.
- b) Interconnecting cables that hang closer than 40 cm to the ground plane shall be folded back and forth in the center forming a bundle 30 to 40 cm long.
- c) I/O cables that are not connected to a peripheral shall be bundled in the center. The end of the cable may be terminated, if required, using the correct terminating impedance. The overall length shall not exceed 1 m.
- d) LISN at least 80 cm from nearest part of EUT chassis.
- e) For the actual test configuration, please refer to the related Item –EUT Test Photos.

### Test Setup

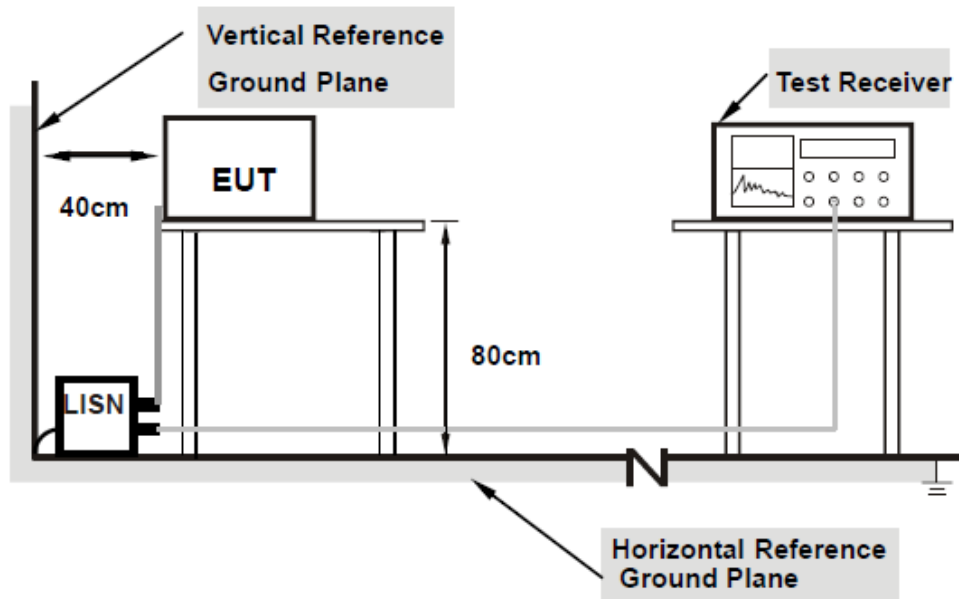

Note:

- 1) Support units were connected to second LISN.
- 2) Both of LISNs (AMN) are 80 cm from EUT and at least 80 from other units and other metal planes

### EUT OPERATING CONDITIONS

The EUT was configured for testing in a typical fashion (as a customer would normally use it). The EUT has been programmed to continuously transmit during test. This operating condition was tested and used to collect the included data.

### Data Sample

No.	Frequency (MHz)	Reading (dBuV)		Correct Factor (dB)	Result (dBuV)		Limit (dBuV)		Margin (dB)		Remark
		QP	AVG		QP	AVG	QP	AVG	QP	AVG	
x	xx.xxxx	39.01	34.65	9.78	48.79	44.43	60	50	-11.21	-5.57	Pass/fail

Correction Factor = insertion loss of LISN + cable loss;

Reading = Reading Amplitude in the instrument;

Result = Correction Factor + Reading;

Margin = Result – Limit.

### Test Results

Pass

**Please refer of Appendix A.**

### 3.2. Radiated Spurious Emission Measurement

#### Limit

In any 100 kHz bandwidth outside the operating frequency band. In case the emission fall within the Restricted band specified on Part15.205 (a)&209(a) and RSS-247 3.3 limit in the table and according to ANSI C63.10-2013 and RSS-Gen below has to be followed.

#### LIMITS OF RADIATED EMISSION MEASUREMENT (0.009MHz - 1000MHz)

For FCC:

Frequencies (MHz)	Field Strength (micorvolts/meter)	Measurement Distance (meters)
0.009~0.490	2400/F(KHz)	300
0.490~1.705	24000/F(KHz)	30
1.705~30.0	30	30
30~88	100	3
88~216	150	3
216~960	200	3
Above 960	500	3

For IC:

Frequencies (MHz)	Field Strength (micorvolts/meter)	Measurement Distance (meters)
0.009~0.490	6.37/F(KHz)	300
0.490~1.705	63.7/F(KHz)	30
1.705~30.0	0.08	30
30~88	100	3
88~216	150	3
216~960	200	3
Above 960	500	3

#### LIMITS OF RADIATED EMISSION MEASUREMENT (1GHz-25 GHz)

FREQUENCY (MHz)	(dBuV/m) (at 3M)	
	PEAK	AVERAGE
Above 1000	74	54

#### Notes:

- 1) The limit for radiated test was performed according to FCC PART 15C.
- 2) The tighter limit applies at the band edges.
- 3) Emission level (dBuV/m)=20log Emission level (uV/m).

## LIMITS OF RESTRICTED FREQUENCY BANDS

For FCC:

FREQUENCY (MHz)	FREQUENCY (MHz)	FREQUENCY (MHz)	FREQUENCY (GHz)
0.090-0.110	16.42-16.423	399.9-410	4.5-5.15
0.495-0.505	16.69475-16.69525	608-614	5.35-5.46
2.1735-2.1905	16.80425-16.80475	960-1240	7.25-7.75
4.125-4.128	25.5-25.67	1300-1427	8.025-8.5
4.17725-4.17775	37.5-38.25	1435-1626.5	9.0-9.2
4.20725-4.20775	73-74.6	1645.5-1646.5	9.3-9.5
6.215-6.218	74.8-75.2	1660-1710	10.6-12.7
6.26775-6.26825	108-121.94	1718.8-1722.2	13.25-13.4
6.31175-6.31225	123-138	2200-2300	14.47-14.5
8.291-8.294	149.9-150.05	2310-2390	15.35-16.2
8.362-8.366	156.52475-156.52525	2483.5-2500	17.7-21.4
8.37625-8.38675	156.7-156.9	2690-2900	22.01-23.12
8.41425-8.41475	162.0125-167.17	3260-3267	23.6-24.0
12.29-12.293	167.72-173.2	3332-3339	31.2-31.8
12.51975-12.52025	240-285	3345.8-3358	36.43-36.5
12.57675-12.57725	322-335.4	3600-4400	Above 38.6
13.36-13.41			

For IC:

FREQUENCY (MHz)	FREQUENCY (MHz)	FREQUENCY (MHz)	FREQUENCY (GHz)
0.090-0.110	13.36-13.41	960-1427	9.0-9.2
0.495-0.505	16.42-16.423	1435-1626.5	9.3-9.5
2.1735-2.1905	16.69475-16.69525	1645.5-1646.5	10.6-12.7
3.020-3.026	16.80425-16.80475	1660-1710	13.25-13.4
4.125-4.128	25.5-25.67	1718.8-1722.2	14.47-14.5
4.17725-4.17775	37.5-38.25	2200-2300	15.35-16.2
4.20725-4.20775	73-74.6	2310-2390	17.7-21.4
5.677-5.683	74.8-75.2	2483.5-2500	22.01-23.12
6.215-6.218	108-138	2655-2900	23.6-24.0
6.26775-6.26825	149.9-150.05	3260-3267	31.2-31.8
6.31175-6.31225	156.52475-156.52525	3332-3339	36.43-36.5
8.291-8.294	156.7-156.9	3345.8-3358	Above 38.6
8.362-8.366	162.0125-167.17	3500-4400	--
8.37625-8.38675	167.72-173.2	4500-5150	--
8.41425-8.41475	240-285	5350-5460	--
12.29-12.293	322-335.4	7250-7750	--
12.51975-12.52025	399.9-410	8025-8500	--
12.57675-12.57725	608-614	--	--



For Radiated Emission	
Spectrum Parameter	Setting
Attenuation	Auto
Detector	Peak/QP/AVG
Start Frequency	9 KHz/150KHz(Peak/QP/AVG)
Stop Frequency	150KHz/30MHz(Peak/QP/AVG)
RB / VB (emission in restricted band)	200Hz (From 9kHz to 0.15MHz)/
	9KHz (From 0.15MHz to 30MHz);
	200Hz (From 9kHz to 0.15MHz)/
	9KHz (From 0.15MHz to 30MHz)
Attenuation	Auto
Detector	Peak/QP
Start Frequency	30 MHz(Peak/QP)
Stop Frequency	1000 MHz (Peak/QP)
RB / VB (emission in restricted band)	120 KHz / 300 KHz
Attenuation	Auto
Detector	Peak/AVG
Start Frequency	1000 MHz(Peak/AVG)
Stop Frequency	10th carrier hamonic(Peak/AVG)
RB / VB (emission in restricted band)	1 MHz / 3 MHz(Peak)
	1 MHz/1/T MHz(AVG)
For Restricted band	
Spectrum Parameter	Setting
Detector	Peak/AVG
Start/Stop Frequency	Lower Band Edge: 2310 to 2410 MHz
	Upper Band Edge: 2476 to 2500 MHz
RB / VB	1 MHz / 3 MHz(Peak)
	1 MHz/1/T MHz(AVG)
Receiver Parameter	Setting
Attenuation	Auto
Start ~ Stop Frequency	9kHz~90kHz / RB 200Hz for Peak & AVG
Start ~ Stop Frequency	90kHz~110kHz / RB 200Hz for QP
Start ~ Stop Frequency	110kHz~490kHz / RB 200Hz for Peak & AVG
Start ~ Stop Frequency	490kHz~30MHz / RB 9kHz for QP
Start ~ Stop Frequency	30MHz~1000MHz / RB 120kHz for QP

**Test Procedure**

- a) The measuring distance of at 3 m shall be used for measurements at frequency 0.009MHz up to 1GHz, and above 1GHz.
- b) The EUT was placed on the top of a rotating table 0.8 meters (above 1GHz is 1.5 m) above the ground at a 3 meter anechoic chamber test site. The table was rotated 360 degrees to determine the position of the highest radiation.
- c) The height of the equipment shall be 0.8 m (above 1GHz is 1.5 m); the height of the test antenna shall vary between 1 m to 4 m. horizontal and vertical polarizations of the antenna are set to make the measurement.
- d) The initial step in collecting conducted emission data is a spectrum analyzer peak detector mode pre-scanning the measurement frequency range. Significant peaks are then marked and then QuasiPeak detector mode re-measured.
- e) If the Peak Mode measured value compliance with and lower than Quasi Peak Mode Limit, the EUT shall be deemed to meet QP Limits and then no additional QP Mode measurement performed.
- f) For the actual test configuration, please refer to the related Item –EUT Test Photos.

**Note:**

Both horizontal and vertical antenna polarities were tested and performed pretest to three orthogonal axis. The worst case emissions were reported.

**DEVIATION FROM TEST STANDARD**

No deviation.

### Test Setup

#### 1. Radiated Emission Test-Up Frequency Below 30MHz

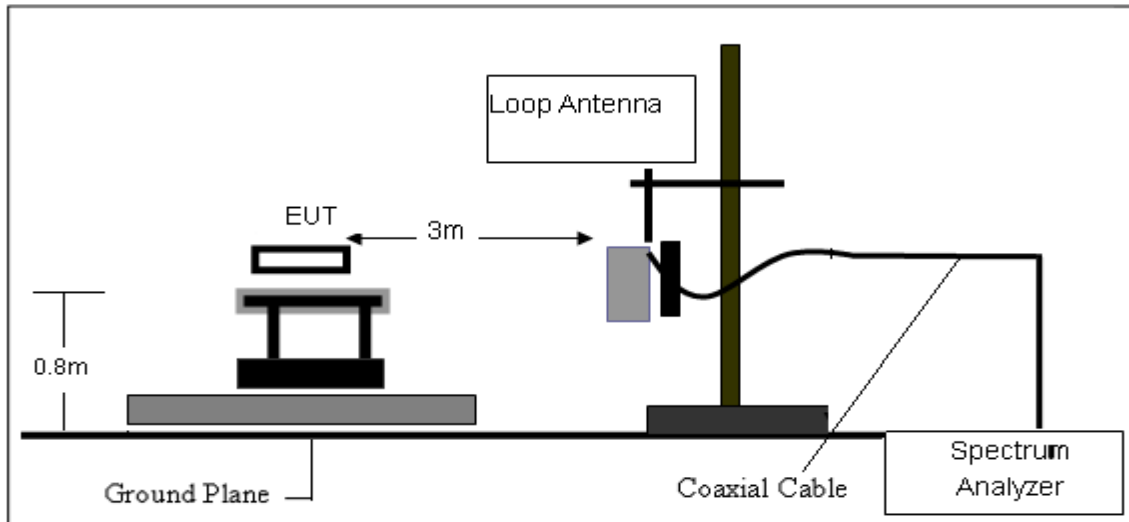

#### 2. Radiated Emission Test-Up Frequency Below 1GHz

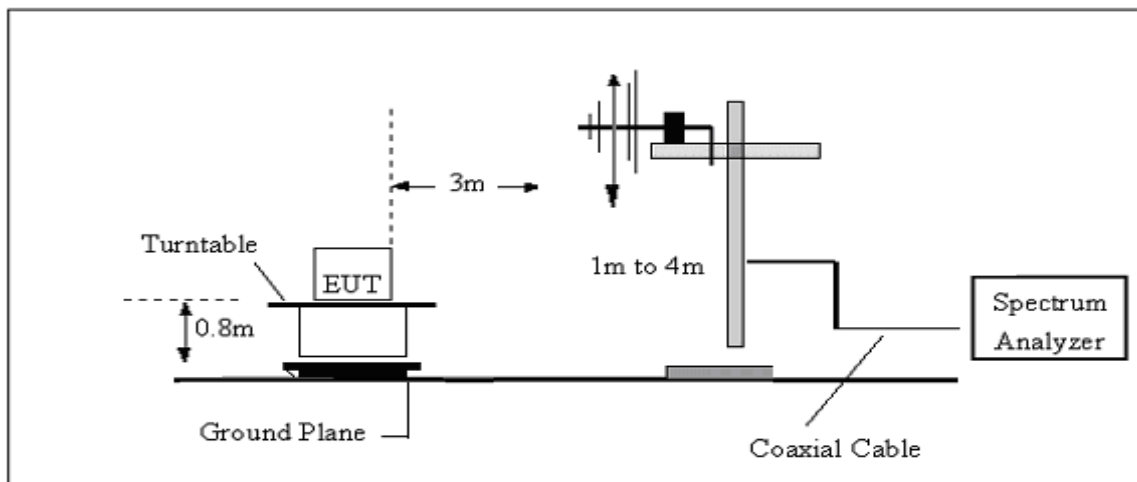

#### 3. Radiated Emission Test-Up Frequency Above 1GHz

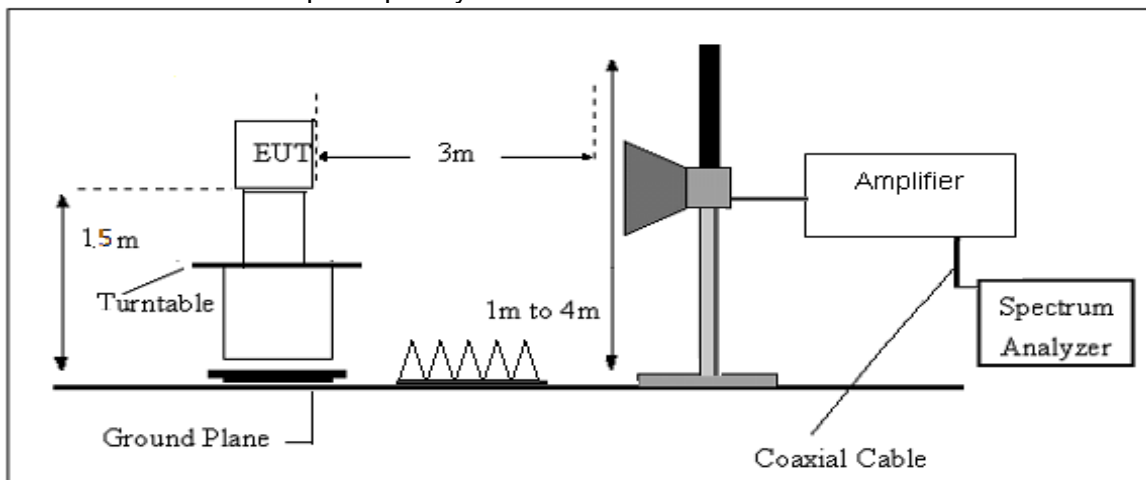

### EUT OPERATING CONDITIONS

The EUT tested system was configured as the statements of 2.5 Unless otherwise a special operating condition is specified in the follows during the testing.

#### Data Sample

Below 1GHz:

No.	Frequency (MHz)	Reading (dBuV)	Correct Factor(dB/m)	Result (dBuV/m)	Limit (dBuV/m)	Margin (dB)	Remark
x	xxx.xxxx	42.72	2.48	45.20	74.00	-28.80	QP

Correction Factor = antenna factor + cable loss – amplifier gain;

Reading = Reading Amplitude in the instrument;

Result = Correction Factor + Reading;

Margin = Result – Limit.

Above 1GHz:

No.	Frequency (MHz)	Reading (dBuV)	Correct Factor(dB/m)	Result (dBuV/m)	Limit (dBuV/m)	Margin (dB)	Remark
1	xxxx.xxx	42.72	2.48	45.20	74.00	-28.80	peak
2	xxxx.xxx	32.75	2.48	35.23	54.00	-18.77	AVG

Correction Factor = antenna factor + cable loss – amplifier gain;

Reading = Reading Amplitude in the instrument;

Result = Correction Factor + Reading;

Margin = Result – Limit.

#### Test Result

Pass

**Please refer of Appendix A.**

### 3.3. Maximum Conducted Output Power Measurement

#### Limit

Type	Test Item	Frequency [MHz]	Limit
FCC	Conducted Output Power	5150-5250	$\leq 250\text{mW}$ (24dBm)
		5250-5350 5470-5725	$\leq 250\text{mW}$ (24dBm) or 11dBm+10logB, where B is the 26 dB emission bandwidth in MHz, where is lesser.
		5725-5850	$\leq 1\text{W}$ (30dBm)
IC	E.I.R.P	5150-5250	$\leq 200\text{mW}$ (23dBm) or 10 dBm + 10 logB, where B is the 99% emission bandwidth in MHz, where is lesser.
		5250-5350 5470-5600	$\leq 1\text{W}$ (30dBm) or 17 + 10 log <sub>10</sub> B, dBm, whichever is less. B is the 99% emission bandwidth in megahertz.
		5650-5725	
	Conducted Output Power	5725-5850	$\leq 1\text{W}$ (30dBm)

#### Test Procedure

The EUT was directly connected to the Power Sensor & PC.

Some regulatory agencies permit the maximum conducted (average) output power to be measured as an alternative to the maximum peak conducted output power for determining compliance to the limit. When this option is exercised, the measured power is to be referenced to the OBW rather than to the DTS bandwidth (see 11.2 for definitions and 6.9.2 for measurement guidance).

When using a spectrum analyzer or EMI receiver to perform these measurements, it shall be capable of utilizing a number of measurement points in each sweep that is greater than or equal to twice the span / RBW, to set a bin-to-bin spacing of  $\leq \text{RBW} / 2$  so that narrowband signals are not lost between frequency bins. If possible, configure or modify the operation of the EUT so that it transmits continuously at its maximum power control level (see 11.6).

The intent is to test at 100% duty cycle; however, a small reduction in duty cycle (to no lower than 98%) is permitted, if required by the EUT for amplitude control purposes. Manufacturers are expected to provide software to the test laboratory to permit such continuous operation.

If continuous transmission (or at least 98% duty cycle) cannot be achieved because of hardware limitations (e.g., overheating), the EUT shall be operated at its maximum power control level, with the transmit duration as long as possible, and the duty cycle as high as possible during which sweep triggering/signal gating techniques may be used to perform the measurement over the transmission duration.

Measurement using a power meter (PM) :

#### 1. Method AVGPM :

Method AVGPM is a measurement using an RF average power meter, as follows:

a) As an alternative to spectrum analyzer or EMI receiver measurements, measurements may be performed using a wideband RF power meter with a thermocouple detector or equivalent if all of the conditions listed below are satisfied:

- 1) The EUT is configured to transmit continuously, or to transmit with a constant duty cycle.
  - 2) At all times when the EUT is transmitting, it shall be transmitting at its maximum power control level.
  - 3) The integration period of the power meter exceeds the repetition period of the transmitted signal by at least a factor of five.
- b) If the transmitter does not transmit continuously, measure the duty cycle, D, of the transmitter

output signal as described in 11.6.

c) Measure the average power of the transmitter. This measurement is an average over both the ON

and OFF periods of the transmitter.

d) Adjust the measurement in dBm by adding  $[10 \log (1 / D)]$ , where D is the duty cycle.

## 2. Method AVGPM-G :

Method AVGPM-G is a measurement using a gated RF average power meter.

Alternatively, measurements may be performed using a wideband gated RF power meter provided that the gate parameters are adjusted such that the power is measured only when the EUT is transmitting at its maximum power control level. Because the measurement is made only during the ON time of the transmitter, no duty cycle correction factor is required.

### Test Configuration

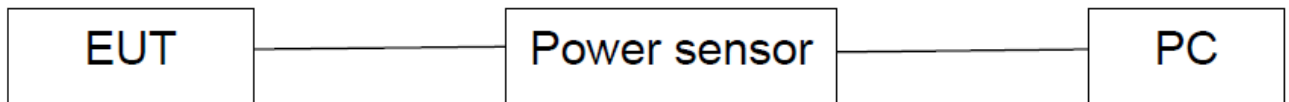

### EUT OPERATION CONDITIONS

The EUT tested system was configured as the statements of 2.4 Unless otherwise a special operating condition is specified in the follows during the testing.

### Test Results

Pass

**Please refer of Appendix A.**

### 3.4. Conducted Power Spectral Density Measurement

#### Limits

Type	Frequency [MHz]	Limit
FCC	5150-5250 5250-5350 5470-5725	$\leq 11\text{dBm/MHz}$
	5725-5850	$\leq 30\text{dBm}/500\text{KHz}$
IC	5150-5250	$\leq 10\text{dBm/MHz}$
	5250-5350	$\leq 11\text{dBm/MHz}$
	5470-5600	
	5650-5725	
5725-5850	$\leq 30\text{dBm}/500\text{KHz}$	

#### Test Procedure

1. The setting follows Method SA-1 of FCC KDB 789033 D02 General U-NII Test Procedures New Rules v02r01.

For devices operating in the band, the rules specify a measurement bandwidth of 500 kHz. Many spectrum analyzers do not have 500 kHz RBW, thus a narrower RBW may need to be used. The rules permit the use of a RBWs less than 1 MHz, or 500 kHz, "provided that the measured power is integrated over the full reference bandwidth" to show the total power over the specified measurement bandwidth (i.e., 1 MHz, or 500 kHz). If measurements are performed using a reduced resolution bandwidth ( $< 1\text{ MHz}$ , or  $< 500\text{ kHz}$ ) and integrated over 1 MHz, or 500 KHz bandwidth, the following adjustments to the procedures apply:

- Set  $\text{RBW} \geq 1/T$ , where T is defined in section II.B.I.a).
- Set  $\text{VBW} \geq 3\text{ RBW}$ .
- If measurement bandwidth of Maximum PSD is specified in 500 kHz, add  $10 \log (500\text{kHz}/\text{RBW})$  to the measured result, whereas  $\text{RBW} (< 500\text{ kHz})$  is the reduced resolution bandwidth of the spectrum analyzer set during measurement.
- If measurement bandwidth of Maximum PSD is specified in 1 MHz, add  $10 \log (1\text{MHz}/\text{RBW})$  to the measured result, whereas  $\text{RBW} (< 1\text{ MHz})$  is the reduced resolution bandwidth of spectrum analyzer set during measurement.
- Care must be taken to ensure that the measurements are performed during a period of continuous transmission or are corrected upward for duty cycle.

Note: As a practical matter, it is recommended to use reduced RBW of 100 kHz for the sections 5.c) and 5.d) above, since  $\text{RBW}=100\text{ KHZ}$  is available on nearly all spectrum analyzers.

#### TEST SETUP



#### EUT OPERATION CONDITIONS

The EUT tested system was configured as the statements of 2.5 Unless otherwise a special operating condition is specified in the follows during the testing.

#### Test Results

Pass

**Please refer of Appendix A.**

### 3.5. 6dB BANDWIDTH Measurement

#### Limits

	Frequency Range (MHz)	Limit
FCC	5725-5850	>500KHz
IC	5725-5850	>500KHz

#### Test Procedure

1. The testing follows FCC KDB 789033 D02 General UNII Test Procedures v02r01.
  - a) Set RBW = 100 kHz.
  - b) Set the video bandwidth (VBW)  $\geq 3 \times$  RBW.
  - c) Detector = Peak.
  - d) Trace mode = max hold.
  - e) Sweep = auto couple.
  - f) Allow the trace to stabilize.
  - g) Measure the maximum width of the emission that is constrained by the frequencies associated with the two outermost amplitude points (upper and lower frequencies) that are attenuated by 6 dB relative to the maximum level measured in the fundamental emission.

#### TEST SETUP



#### EUT OPERATION CONDITIONS

The EUT tested system was configured as the statements of 2.4 Unless otherwise a special operating condition is specified in the follows during the testing.

#### Test Results

Pass

**Please refer of Appendix A.**



### 3.6. 26dB BANDWIDTH Measurement

#### Limits

	Frequency Range (MHz)	Limit
FCC	5150-5250	/
	5250-5350	/
	5470-5725	/

#### Test Procedure

1. The testing follows FCC KDB 789033 D02 General UNII Test Procedures New Rules v02r01.
2. Set RBW = approximately 1% of the emission bandwidth.
3. Set the VBW  $\geq$  RBW.
4. Detector = Peak.
5. Trace mode = max hold.
6. Measure the maximum width of the emission that is 26 dB down from the peak of the emission. Compare this with the RBW setting of the analyzer. Readjust RBW and repeat measurement as needed until the RBW/EBW ratio is approximately 1%.

#### TEST SETUP

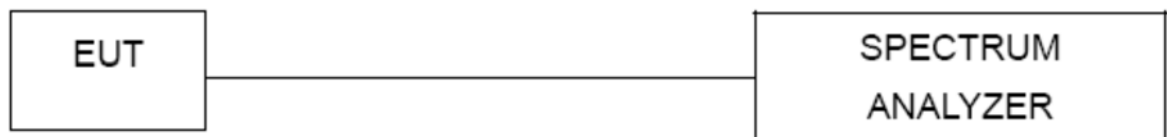

#### EUT OPERATION CONDITIONS

The EUT tested system was configured as the statements of 2.4 Unless otherwise a special operating condition is specified in the follows during the testing.

#### Test Results

Pass

**Please refer of Appendix A.**

### 3.7. 99% BANDWIDTH Measurement

#### Limits

	Frequency Range (MHz)	Limit
IC	5150-5250	/
	5250-5350	/
	5470-5600	/
	5650-5725	/

#### Test Procedure

The testing follows FCC KDB 789033 D02 General UNII Test Procedures v02r01.

The following procedure shall be used for measuring (99 %) power bandwidth:

1. Set center frequency to the nominal EUT channel center frequency.
2. Set span = 1.5 times to 5.0 times the OBW.
3. Set RBW = 1 % to 5 % of the OBW
4. Set VBW  $\geq 3 \cdot$  RBW
5. Video averaging is not permitted. Where practical, a sample detection and single sweep mode shall be used. Otherwise, peak detection and max hold mode (until the trace stabilizes) shall be used.
6. Use the 99 % power bandwidth function of the instrument (if available).
7. If the instrument does not have a 99 % power bandwidth function, the trace data points are recovered and directly summed in power units. The recovered amplitude data points, beginning at the lowest frequency, are placed in a running sum until 0.5 % of the total is reached; that frequency is recorded as the lower frequency. The process is repeated until 99.5 % of the total is reached; that frequency is recorded as the upper frequency. The 99% occupied bandwidth is the difference between these two frequencies.

#### TEST SETUP



#### EUT OPERATION CONDITIONS

The EUT tested system was configured as the statements of 2.4 Unless otherwise a special operating condition is specified in the follows during the testing.

#### Test Results

Pass

**Please refer of Appendix A.**

### 3.8. Frequency Stability Measurement

#### Limits

	Frequency Range (MHz)	Limit
FCC	5150-5250	25ppm
	5250-5350	25ppm
	5470-5725	25ppm
	5725-5850	25ppm

#### Test Procedure

- (1) To ensure emission at the band edge is maintained within the authorized band, those values shall be measured by radiation emissions at upper and lower frequency points, and finally compensated by frequency deviation as procedures below.
- (2) The EUT was operated at the maximum output power, and connected to the spectrum analyzer, which is set to maximum hold function and peak detector. The peak value of the power envelope was measured and noted. The upper and lower frequency points were respectively measured relatively 10 dB lower than the measured peak value.
- (3) The frequency deviation was calculated by adding the upper frequency point and the lower frequency point divided by two. Those detailed values of frequency deviation are provided in table below.

#### TEST SETUP



#### EUT OPERATION CONDITIONS

The EUT tested system was configured as the statements of 2.4 Unless otherwise a special operating condition is specified in the follows during the testing.

#### Test Results

Pass

**Please refer of Appendix A.**

### 3.9. Dynamic Frequency Selection (DFS) Measurement

#### Applicability of DFS requirements

Applicability of DFS Requirements Prior to Use of a Channel

Requirement	Operational Mode		
	<input type="checkbox"/> Master	<input type="checkbox"/> Client Without Radar Detection	<input type="checkbox"/> Client with Radar Detection
Non-Occupancy Period	Yes	Not required	Yes
DFS Detection Threshold	Yes	Not required	Yes
Channel Availability Check Time	Yes	Not required	Not required
U-NII Detection Bandwidth	Yes	Not required	Yes

Applicability of DFS requirements during normal operation

Requirement	Operational Mode	
	<input type="checkbox"/> Master Device or Client with Radar Detection	<input type="checkbox"/> Client Without Radar Detection
DFS Detection Threshold	Yes	Not required
Channel Closing Transmission Time	Yes	Yes
Channel Move Time	Yes	Yes
U-NII Detection Bandwidth	Yes	Not required

Additional requirements for devices with multiple bandwidth modes	<input type="checkbox"/> Master Device or Client with Radar Detection	<input type="checkbox"/> Client Without Radar Detection
U-NII Detection Bandwidth and Statistical Performance Check	All BW modes must be tested	Not required
Channel Move Time and Channel Closing Transmission Time	Test using widest BW mode available	Test using the widest BW Mode available for the link
All other tests	Any single BW mode	Not required
Note: Frequencies selected for statistical performance check should include several frequencies within the radar detection bandwidth and frequencies near the edge of the radar detection bandwidth. For 802.11 devices it is suggested to select frequencies in each of the bonded 20MHz channels and the channel center frequency.		

#### Limit

DFS Detection Thresholds for Master Devices and Client Devices with Radar Detection

Maximum Transmit Power	Value (See Notes 1, 2, and 3)
EIRP $\geq$ 200 milliwatt	-64 dBm
EIRP < 200 milliwatt and power spectral density < 10 dBm/MHz	-62 dBm
EIRP < 200 milliwatt that do not meet the power spectral density requirement	-64 dBm

Note 1: This is the level at the input of the receiver assuming a 0 dBi receive antenna.

Note 2: Throughout these test procedures an additional 1 dB has been added to the amplitude of the test transmission waveforms to account for variations in measurement equipment. This will ensure that the test signal is at or above the detection threshold level to trigger a DFS response.

Note3: EIRP is based on the highest antenna gain. For MIMO devices refer to KDB Publication 662911 D01.

## DFS Response Requirement Values

Parameter	Value
Non-occupancy period	Minimum 30 minutes
Channel Availability Check Time	60 seconds
Channel Move Time	10 seconds See Note 1.
Channel Closing Transmission Time	200 milliseconds + an aggregate of 60 milliseconds over remaining 10 second period. See Notes 1 and 2.
U-NII Detection Bandwidth	Minimum 100% of the U-NII 99% transmission power bandwidth. See Note 3.

Note 1: Channel Move Time and the Channel Closing Transmission Time should be performed with Radar Type 0. The measurement timing begins at the end of the Radar Type 0 burst.

Note 2: The Channel Closing Transmission Time is comprised of 200 milliseconds starting at the beginning of the Channel Move Time plus any additional intermittent control signals required facilitating a Channel move (an aggregate of 60 milliseconds) during the remainder of the 10 second period. The aggregate duration of control signals will not count quiet periods in between transmissions.

Note 3: During the U-NII Detection Bandwidth detection test, radar type 0 should be used. For each frequency step the minimum percentage of detection is 90 percent. Measurements are performed with no data traffic.

### Parameters of radar test waveforms

This section provides the parameters for required test waveforms, minimum percentage of successful detections, and the minimum number of trials that must be used for determining DFS conformance. Step intervals of 0.1 microsecond for Pulse Width, 1 microsecond for PRI, 1 MHz for chirp width and 1 for the number of pulses will be utilized for the random determination of specific test waveforms.

#### Short Pulse Radar Test Waveforms

Radar Type	Pulse Width (μsec)	PRI (μsec)	Number of Pulses	Minimum Percentage of Successful Detection	Minimum Number of Trials
0	1	1428	18	See Note 1	See Note 1
1	1	Test A: 15 unique PRI values randomly selected from the list of 23 PRI values in Table 5a	Roundup $\left\{ \left( \frac{1}{360} \right) \cdot \left( \frac{19 \cdot 10^6}{\text{PRI}_{\mu\text{sec}}} \right) \right\}$	60%	30
		Test B: 15 unique PRI values randomly selected within the range of 518-3066 μsec, with a minimum increment of 1 μsec, excluding PRI values selected in Test A			
2	1-5	150-230	23-29	60%	30
3	6-10	200-500	16-18	60%	30
4	11-20	200-500	12-16	60%	30
Aggregate (Radar Types 1-4)				80%	120

Note 1: Short Pulse Radar Type 0 should be used for the detection bandwidth test, channel move time, and channel closing time tests.

A minimum of 30 unique waveforms are required for each of the Short Pulse Radar Types 2 through 4. If more than 30 waveforms are used for Short Pulse Radar Types 2 through 4, then each

additional

waveform must also be unique and not repeated from the previous waveforms. If more than 30 waveforms are used for Short Pulse Radar Type 1, then each additional waveform is generated with Test

B and must also be unique and not repeated from the previous waveforms in Tests A or B.

### **Calibration of radar waveform**

Radar Waveform Calibration Procedure:

(1) A 50 ohm load is connected in place of the spectrum analyzer, and the spectrum analyzer is connected to place of the master

(2) The interference Radar Detection Threshold Level is  $-62\text{dBm} + 0\text{dBi} + 1\text{dB} = -61\text{dBm}$  that had been taken into account the output power range and antenna gain.

(3) The following equipment setup was used to calibrate the conducted radar waveform. A vector signal generator was utilized to establish the test signal level for radar type 0. During this process there were no transmissions by either the master or client device. The spectrum analyzer was switched to the zero spans (time domain) at the frequency of the radar waveform generator. Peak detection was used. The spectrum analyzer resolution bandwidth (RBW) and video bandwidth (VBW) were set to 3 MHz. The spectrum analyzer had offset  $-1.0\text{dB}$  to compensate RF cable loss  $1.0\text{dB}$ .

(4) The vector signal generator amplitude was set so that the power level measured at the spectrum analyzer was  $-62\text{dBm} + 0\text{dBi} + 1\text{dB} = -61\text{dBm}$ . Capture the spectrum analyzer plots on short pulse radar waveform.

Conducted Calibration Setup:

### **Channel closing transmission time, channel move time and non-occupancy period**

Block diagram of test setup Test Procedure:

(1) The radar pulse generator is setup to provide a pulse at frequency that the master and client are operating. A type 0 radar pulse with a  $1\mu\text{s}$  pulse width and a  $1428\mu\text{s}$  PRI is used for the testing.

(2) The vector signal generator is adjusted to provide the radar burst (18 pulses) at the level of approximately  $-61\text{dBm}$  at the antenna port of the master device.

(3) A trigger is provided from the pulse generator to the DFS monitoring system in order to capture the traffic and the occurrence of the radar pulse.

(4) EUT will associate with the master at channel. The file "iperf.exe" specified by the FCC is streamed from the PC 2 through the master and the client device to the PC 1 and played in full motion video using Test Software in order to properly load the network for the entire period of the test.

(5) When radar burst with a level equal to the DFS Detection Threshold  $+1\text{dB}$  is generated on the operating channel of the U-NII device. At time  $T_0$  the radar waveform generator sends a burst of pulse of the radar waveform at Detection Threshold  $+1\text{dB}$ .

(6) Observe the transmissions of the EUT at the end of the radar Burst on the Operating Channel. Measure and record the transmissions from the UUT during the observation time (Channel Move Time). One 15 seconds plot is reported for the Short Pulse Radar Type 0. The plot for the Short Pulse Radar Types start at the end of the radar burst. The Channel Move Time will be calculated based on the zoom in  $600\text{ms}$  plot of the Short Pulse Radar Type.

(7) Measurement of the aggregate duration of the Channel Closed Transmission Time method. With the

(8) spectrum analyzer set to zero span tuned to the center frequency of the EUT operating channel at the radar simulated frequency, peak detection, and max hold, the dwell time per bin is given by:  $D_{\text{well}} (0.3\text{ms}) = S (12000\text{ms}) / B (4000)$ ; where  $D_{\text{well}}$  is the dwell time per spectrum analyzer sampling bin,  $S$  is sweep time and  $B$  is the number of spectrum analyzer sampling bins. An upper bound of the aggregate duration of the intermittent control signals of Channel Closing Transmission Time is calculated by:  $C (\text{ms}) = N \times D_{\text{well}} (0.3\text{ms})$ ; where  $C$  is the Closing Time,  $N$  is the number of spectrum analyzer sampling bins (intermittent control

signals) showing a U-NII transmission and Dwell is the dwell time per bin.

(9) Measurement the EUT for more than 30 minutes following the channel move time to verify that no transmission or beacons occur on this channel.

### Test setup

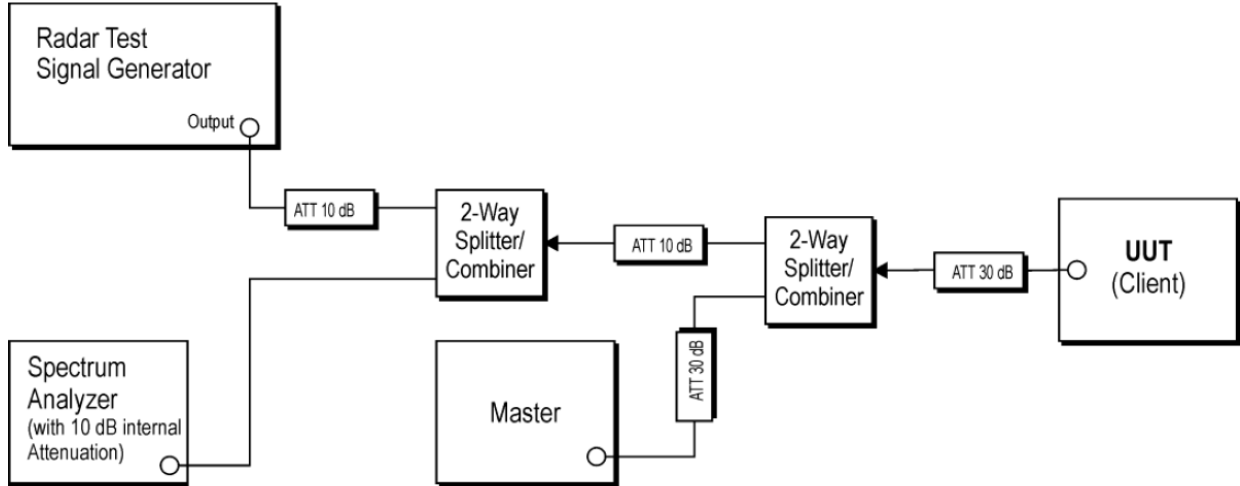

### Test result

**Not applicable, the product only operates in the 5150-5250MHz and 5725-5850MHz frequency bands.**



### 3.10. ANTENNA REQUIREMENT

#### STANDARD REQUIREMENT

According to the manufacturer declared, the EUT has Two external antenna, the directional gain of antenna is 2.34 dBi for 5150MHz-5250MHz, 3.14 dBi for 5725MHz-5850MHz, and the antenna connector is designed with a reverse polarity socket and does not consider replacement. Therefore, the EUT is considered sufficient to comply with the provision.

#### EUT ANTENNA

The EUT antenna is external antenna. It comply with the standard requirement.





## 4. TEST PHOTOS

Please refer of Appendix D Test Setup.

## 5. EUT PHOTOS

External Photos Please refer of Appendix B and Internal Photos Please refer of Appendix C.

\*\*\*\*\*THE END\*\*\*\*\*