

# Test Report

**Product Name** .....: WIRELESS VIDEO TRANSMISSION SYSTEM  
**Trademark** .....: HOLLYLAND  
**Model No** .....: Mars 4K  
**Series Model** .....: See section 2.1 for details  
**FCC ID**.....: 2ADZC-9802GT  
**Report No** .....: C220711010-RF06  
**Test Standards**.....: FCC Part 15.407  
ANSI C63.10-2013  
**Applicant** .....: Shenzhen Hollyland Technology Co.,Ltd  
**Address of Applicant**.....: 8F,Building 5D,Skyworth Innovation Valley, Tangtou Road.  
Shiyan Street, Baoan District Shenzhen, China.  
**Manufacturer**.....: Shenzhen Hollyland Technology Co.,Ltd  
**Manufacturer Address**.....: 8F,Building 5D,Skyworth Innovation Valley, Tangtou Road.  
Shiyan Street, Baoan District Shenzhen, China.  
**Date of Test Date**.....: Jul.11,2022 to Aug.02,2022  
**Date of Issue**.....: Aug.08,2022  
**Test Result**.....: Compliance

**Testing Engineer** : Jeff. Yang

**Reviewed By** : Adil - yang

**Approved Signatory** : Tom. Chen

The test results in the report only apply to the tested sample. The test report shall be invalid without all the signatures of testing engineers, reviewer and approver. Any objections must be raised to CSIC within 15 days since the date when the report is received. It will not be taken into consideration beyond this limit.

**Table of Contents**
**Page**

<b>1</b>	<b>TEST SUMMARY.....</b>	<b>3</b>
1.1	TEST DESCRIPTION.....	3
1.2	TEST DESCRIPTION.....	3
1.3	TEST FACILITY .....	4
1.4	MEASUREMENT UNCERTAINTY .....	4
<b>2</b>	<b>GENERAL INFORMATION.....</b>	<b>5</b>
2.1	GENERAL DESCRIPTION OF EUT .....	5
2.2	DESCRIPTION OF TEST MODES AND TEST FREQUENCY.....	6
2.3	MEASUREMENT INSTRUMENTS LIST .....	7
2.4	DESCRIPTION OF THE TEST MODES.....	8
2.5	TEST SOFTWARE AND POWER LEVEL .....	8
2.6	BLOCK DIGRAM SHOWING THE CONFIGURATION OF SYSTEM TESTED .....	8
2.7	DESCRIPTION OF NECESSARY ACCESSORIES AND SUPPORT UNITS .....	9
<b>3</b>	<b>EMC EMISSION TEST .....</b>	<b>10</b>
3.1	CONDUCTED EMISSION MEASUREMENT .....	10
3.2	RADIATED EMISSION MEASUREMENT .....	13
<b>4</b>	<b>RF CONDUCTED TEST .....</b>	<b>31</b>
4.1	CONDUCTED SPURIOUS & BAND EDGE EMISSION.....	31
4.2	POWER SPECTRAL DENSITY TEST .....	33
4.3	BANDWIDTH TEST.....	35
4.4	MAXIMUM CONDUCTED OUTPUT POWER.....	41
4.5	AUTOMATICALLY DISCONTINUE TRANSMISSION.....	43
4.6	ANTENNA REQUIREMENT .....	44
<b>5</b>	<b>EUT PHOTOS.....</b>	<b>45</b>

# 1 TEST SUMMARY

## 1.1 Test Description

Test procedures according to the technical standards:  
Part 15.407,KDB 789033 D02 General U-NII Test Procedures New Rules v02r01

## 1.2 Test Description

FCC Part 15.247,Subpart C			
Item	Clause	Result	Remark
Conducted Emission	15.207	Pass	/
Maximum Conducted Output Power	15.407(a)(1).(2).(3).(4).(5)	Pass	/
Radiated Emission And (bandedge Emissions) Measurement	15.407(b) & 15.209	Pass	/
Conducted Emission And (bandedge Emissions) Measurement	15.407(b)7	Pass	/
Power Spectral Density	15.407(a)(1).(2).(3).(4).(5)	Pass	/
26dB/6dB &99% Bandwidth	15.407 (2) (26 dB) / 15.407 (e) (6 dB)/ 15.407 (a) (99%)	Pass	/
Automatically Discontinue Transmission	15.407(c)	Pass	/
Antenna Requirement	15.203/15.204	Pass	/
<b>NOTE:</b>			
1) 'N/A' denotes test is not applicable in this Test Report.			
2) All tests are according to ANSI C63.10-2013.			

### 1.3 Test Facility

Shenzhen Central Standard International Center Co., Ltd.  
 Room 201, Building 1, Mogen Fashion Industrial Park, No. 10, Shilongzai Road, Xinshi Community, Dalang Street,  
 Longhua District, Shenzhen

The test facility is recognized, certified or accredited by the following organizations:

CNAS – Registration NO.: L11671

FCC - Registration NO.: 0031378433      Designation Number: CN1317

IC – CAB identifier: CN0051

A2LA – Lab Cert. No.: 6426.01

### 1.4 Measurement Uncertainty

The data and results referenced in this document are true and accurate. The reader is cautioned that there may be errors within the calibration limits of the equipment and facilities. The measurement uncertainty was calculated for all measurements listed in this test report acc. To CISPR 16 – 4 Specification for radio disturbance and immunity measuring apparatus and methods – Part 4: Uncertainty in EMC Measurements and is documented in the Shenzhen Central Standard International Center Co., Ltd. quality system acc. To DIN EN ISO/IEC 17025. Furthermore, component and process variability of devices similar to that tested may result in additional deviation. The manufacturer has the sole responsibility of continued compliance of the device. Below is the best measurement capability for Shenzhen Central Standard International Center Co.,Ltd.

Test Items	Measurement Uncertainty
RF output power, conducted	±0.59dB
Unwanted Emissions, conducted	±2.20dB
All emissions, radiated 30-1GHz	±1.76dB
All emissions, radiated 1G-6GHz	±2.34dB
All emissions, radiated>6G	±2.34dB
Conducted Emission (9KHz-150KHz)	±1.60dB
Conducted Emission (150KHz-30MHz)	±3.678dB
<b>Remark:</b> 1) This uncertainty represents an expanded uncertainty expressed at approximately the 95%. 2) Confidence level using a coverage factor of K=2.	

## 2 GENERAL INFORMATION

### 2.1 General Description of EUT

Product information	
Product Name:	WIRELESS VIDEO TRANSMISSION SYSTEM
Trademark:	HOLLYLAND
Model No:	Mars 4K
Series Model:	Mars 4K, Mars 4K Pro, Mars 4K Plus, Mars 4K s
Power supply:	Adapter      DC 12V 1A, 12W
Hardware version:	9802G-TX-V18
Software version:	V1.0.0.5
WIFI information	
Modulation:	802.11n(OFDM): BPSK, QPSK,16-QAM, 64-QAM
Operation frequency:	IEEE 802.11n(HT20): 5.180GHz-5.240GHz, 5.745-5.825GHz
Operation bandwidth:	20 MHz
Channel separation:	IEEE 802.11n(HT20): 8
Antenna type:	Portable antenna
Antenna gain:	4.50dBi
<b>Remark:</b>	
<p>This document is only valid for the transmitting part of the EUT. For the receiving part of the EUT, please refer to parameter C220711010-RF07.</p> <p>The product communication is designed according to 802.11n protocol. This design only opens the frequency points provided in this document and only uses 20m nominal bandwidth.</p> <p>All models are same with each in hardware and electronic aspects, only model number are different for market strategy.</p> <p>The shape or color of the base of the EUT and the color of the frame do not affect the performance of the EUT. For details refer to the User Manual, Technical Description and Circuit Diagram.</p>	
Product factory information	
Factory Name:	Shenzhen Hollyland Technology Co.,Ltd
Factory address:	8F,Building 5D,Skyworth Innovation Valley, Tangtou Road. Shiyan Street, Baoan District Shenzhen, China.

**Remark: The above information and materials are provided by the Manufacturer.**

## 2.2 Description of Test Modes and Test Frequency

The EUT has been tested under typical operating condition. The Applicant provides communication tools software to control the EUT for staying in continuous transmitting and receiving mode for testing.

### Operation Frequency List WIFI:

Operation Frequency of channel			
5.180GHz-5.240GHz		5.745GHz-5.825GHz	
Channel	Frequency	Channel	Frequency
36	5180	149	5745
40	5200	153	5765
44	5220	157	5785
48	5240	165	5825

Note:

In section 15.31(m), regards to the operating frequency range over 10 MHz, the Lowest frequency, the middle frequency, and the highest frequency of channel were selected to perform the test, and the selected channel see below.

### Carrier Frequency Channel:

For 802.11n(HT20)		
Test Channel	EUT Channel	Test Frequency (MHz)
lowest	CH36	5180
middle	CH40	5200
highest	CH48	5240
...		
lowest	CH149	5745
middle	CH157	5785
highest	CH165	5825

Remark: Since the product contains two prototypes, the transmitter and receiver prototypes are used together, the false transmissions of TX and Rx of each prototype are tested respectively.

## 2.3 Measurement Instruments List

RF Connected Test					
Item	Test Equipment	Manufacturer	Model No.	Serial No.	Calibrated until
1	Spectrum Analyzer	Agilent	N9020A	MY50200391	Jun. 13, 2023
2	Power sensor	KEYSIGHT	U2021XA	MY55080015	Jun. 13, 2023
3	Power sensor	KEYSIGHT	U2021XA	MY54250016	Jun. 13, 2023
4	Power sensor	KEYSIGHT	U2021XA	MY54250020	Jun. 13, 2023
5	Power sensor	KEYSIGHT	U2021XA	MY54210030	Jun. 13, 2023
6	Vector Signal Generator	Agilent	N5182A	MY50140130	Jun. 13, 2023
7	Signal generator	Agilent	SML03	100925	Jun. 13, 2023
8	Power sensor Box	MWRFTest	N/A	N/A	N/A
9	RF Switch Box	MWRFTest	MW100-RF CB	N/A	N/A
10	MTS 8310	MWRFTest	V: 2.0.0.0		

Radiation Test equipment					
Item	Test Equipment	Manufacturer	Model No.	Serial No.	Calibrated until
1	EMI TEST RECEIVER	R&S	ESIB26	100342	Jun. 13, 2023
2	Amplifier	HP	8447F	2634A02050	Jun. 13, 2023
3	Amplifier	Agilent	8449B	4035A00116	Jun. 13, 2023
4	Bilog Antenna	Schwarzbeck	VULB-9168	VULB9168-250	Jul. 25, 2025
5	Horn Antenna	AARONIAAG	Powerlog 70180	3980	Jul. 04, 2025
6	EZ-EMC	Farad	V3.1		

Note:

1. The cable loss has calculated in test result which connection between each test instruments.

## 2.4 Description Of The Test Modes

To investigate the maximum EMI emission characteristics generates from EUT, the test system was pre-scanning tested base on the consideration of following EUT operation mode or test configuration mode which possible have effect on EMI emission level. Each of these EUT operation mode(s) or test configuration mode(s) mentioned above was evaluated respectively.

Worst Mode	Description	Data Rate
Mode 1	802.11n HT20 CH36&CH40&CH48	MCS 0
Mode 2	802.11n HT20 CH149&CH157&CH165	MCS 0

Note:

- (1) The measurements are performed at all Bit Rate of Transmitter, the worst data was reported.
- (2) The battery is full-charged during the radiated and RF conducted test.

For AC Conducted Emission

Test Case	
AC Conducted Emission	Mode3: Working

## 2.5 Test Software And Power Level

During testing channel & power controlling software provided by the customer was used to control the operating channel as well as the output power level.

RF Function	Type	Mode Or Modulation type	Ant Gain(dBi)	Ant_A Power Class	Ant_B Power Class	Software For Testing
WIFI(5G)	5G WIFI Band1 (5150MHz-5250MHz)	802.11n(HT20)	4.50	11	11	AP22-art 2_ver_2_ 28_7BIN -6703
RF Function	Type	Mode Or Modulation type	Ant Gain(dBi)	Ant_A Power Class	Ant_B Power Class	Software For Testing
WIFI(5G)	5G WIFI Band4 (5725MHz-5850MHz)	802.11n(HT20)	4.50	11	11	AP22-art 2_ver_2_ 28_7BIN -6703

## 2.6 Block Digram Showing The Configuration Of System Tested

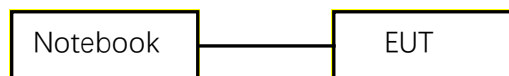



## 2.7 Description Of Necessary Accessories And Support Units

The EUT has been tested as an independent unit together with other necessary accessories or support units. The following support units or accessories were used to form a representative test configuration during the tests.

Necessary accessories					
Item	Equipment	Mfr/Brand	Model/Type No.	Serial No.	Note
N/A	N/A	N/A	N/A	N/A	N/A

Support units					
Item	Equipment	Mfr/Brand	Model/Type No.	Serial No.	Note
E-1	Notebook	Dell	Vostro 3400	35845130379	AE

**Note:**

- (1) The support equipment was authorized by Declaration of Confirmation.
- (2) For detachable type I/O cable should be specified the length in cm in 『Length』 column.

### 3 EMC EMISSION TEST

#### 3.1 Conducted Emission Measurement

##### 3.1.1 Limit

Operating frequency band. In case the emission fall within the restricted band specified on Part 207(a) limit in the table below has to be followed.

FREQUENCY (MHz)	Conducted Emission limit (dBuV)	
	Quasi-peak	Average
0.15 - 0.5	66 - 56 *	56 - 46 *
0.5 - 5	56	46
5 - 30	60	50

Note:

- 1) The tighter limit applies at the band edges.
- 2) The limit of “ \* ” marked band means the limitation decreases linearly with the logarithm of the frequency in the range.

The following table is the setting of the receiver:

Receiver Parameters	Setting
Attenuation	10 dB
Start Frequency	0.15 MHz
Stop Frequency	30 MHz
RBW	9 kHz

##### 3.1.2 Test Procedure

1. The EUT was 0.8 meters from the horizontal ground plane and 0.4 meters from the vertical ground plane with EUT being connected to the power mains through a line impedance stabilization network (LISN). All other support equipment's powered from additional LISN(s). The LISN provide 50 Ohm/ 50uH of coupling impedance for the measuring instrument.
2. Interconnecting cables that hang closer than 40 cm to the ground plane shall be folded back and forth in the center forming a bundle 30 to 40 cm long.
3. I/O cables that are not connected to a peripheral shall be bundled in the center. The end of the cable may be terminated, if required, using the correct terminating impedance. The overall length shall not exceed 1 m.
4. LISN at least 80 cm from nearest part of EUT chassis.
5. For the actual test configuration, please refer to the related Item –EUT Test Photos.

### 3.1.3 Test Setup

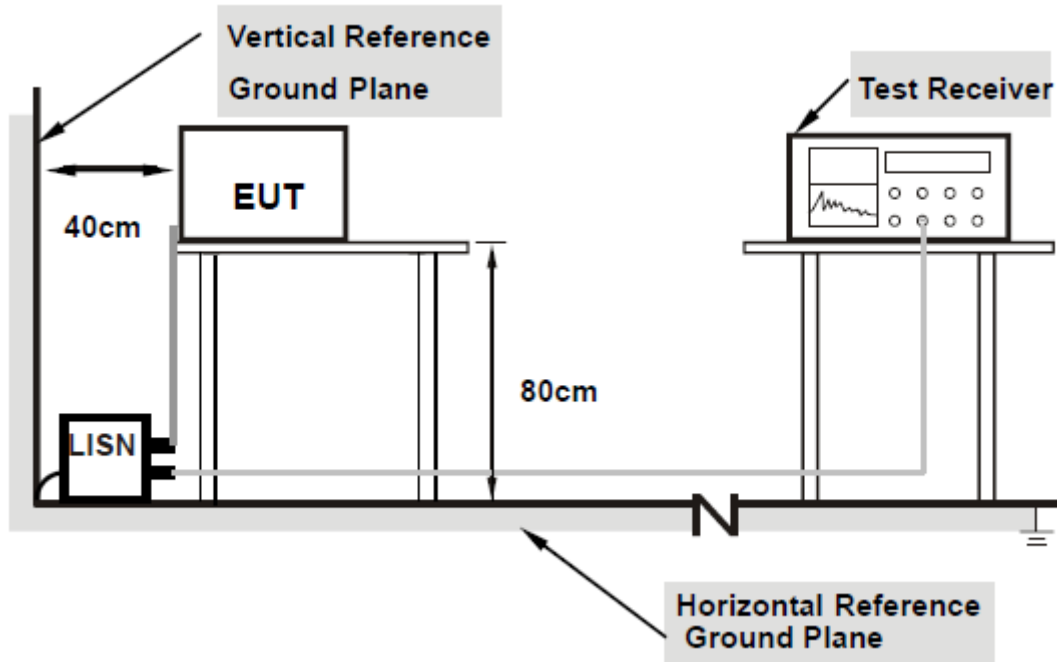

Note:

1. Support units were connected to second LISN.
2. Both of LISNs (AMN) are 80 cm from EUT and at least 80 from other units and other metal planes

### 3.1.4 EUT Operating Conditions

The EUT was configured for testing in a typical fashion (as a customer would normally use it). The EUT has been programmed to continuously transmit during test. This operating condition was tested and used to collect the included data.

### 3.1.5 Test Result

Temperature:		27.1°C		Relative Humidity:		40.0%	
Test Voltage:		120V 60Hz		Phase:		L	
Test Mode:		Mode 3					
No.	Frequency (MHz)	Reading (dBuV)	Correct Factor(dB)	Result (dBuV)	Limit (dBuV)	Margin (dB)	Remark
1	0.1580	45.88	10.14	56.02	65.56	-9.54	Pass
2	0.1580	28.76	10.14	38.90	55.57	-16.67	Pass
3	0.2180	42.65	10.10	52.75	62.59	-10.14	Pass
4	0.2180	21.43	10.10	31.53	52.89	-21.36	Pass
5	0.2819	36.37	10.09	46.46	60.76	-14.30	Pass
6	0.2819	16.00	10.09	26.09	50.76	-24.67	Pass
7	0.3660	33.04	10.09	43.13	58.59	-15.46	Pass
8	0.3660	17.07	10.09	27.16	48.59	-21.43	Pass
9	0.4420	34.82	10.09	44.91	57.02	-12.11	Pass
10	0.4420	15.01	10.09	25.10	47.02	-21.92	Pass
11	9.1220	32.02	9.85	41.87	60.00	-18.13	Pass
12	9.1220	18.56	9.85	28.41	50.00	-21.59	Pass

Temperature:		27.1°C		Relative Humidity:		40.0%	
Test Voltage:		120V 60Hz		Phase:		N	
Test Mode:		Mode 3					
No.	Frequency (MHz)	Reading (dBuV)	Correct Factor(dB)	Result (dBuV)	Limit (dBuV)	Margin (dB)	Remark
1	0.1580	46.51	10.17	56.68	65.56	-8.88	Pass
2	0.1580	20.45	10.17	30.62	55.57	-24.95	Pass
3	0.1980	40.22	10.16	50.38	63.69	-13.31	Pass
4	0.1980	18.57	10.16	28.73	53.69	-24.96	Pass
5	0.2620	34.45	10.10	44.55	61.36	-16.81	Pass
6	0.2620	14.44	10.10	24.54	51.37	-26.83	Pass
7	0.4740	30.00	10.04	40.04	56.44	-16.40	Pass
8	0.4740	23.25	10.04	33.29	46.44	-13.115	Pass
9	2.2940	26.23	10.00	36.23	56.00	-19.77	Pass
10	2.2940	12.59	10.00	22.59	46.00	-23.41	Pass
11	9.4020	32.58	9.79	42.37	60.00	-17.63	Pass
12	9.4020	20.04	9.79	29.83	50.00	-20.17	Pass

Remark:

1. All readings are Quasi-Peak and Average values
2. Margin = Result (Result = Reading + Factor) - Limit
3. Factor = LISN factor + Cable loss + Limiter (10dB)

## 3.2 RADIATED EMISSION MEASUREMENT

### 3.2.1 Limit

In any 100 kHz bandwidth outside the operating frequency band. In case the emission fall within the Restricted band specified on Part15.205 (a)&209(a) limit in the table and according to ANSI C63.10-2013 below has to be followed.

#### LIMITS OF RADIATED EMISSION MEASUREMENT (0.009MHz - 1000MHz)

Frequencies (MHz)	Field Strength (micorvolts/meter)	Measurement Distance (meters)
0.009~0.490	2400/F(KHz)	300
0.490~1.705	24000/F(KHz)	30
1.705~30.0	30	30
30~88	100	3
88~216	150	3
216~960	200	3
Above 960	500	3

#### LIMITS OF RADIATED EMISSION MEASUREMENT (1GHz-25 GHz)

FREQUENCY (MHz)	(dBuV/m) (at 3M)	
	PEAK	AVERAGE
Above 1000	74	54

#### Notes:

- 1.The limit for radiated test was performed according to FCC PART 15C.
- 2.The tighter limit applies at the band edges.
- 3.Emission level (dBuV/m)=20log Emission level (uV/m).

#### LIMITS OF RESTRICTED FREQUENCY BANDS

FREQUENCY (MHz)	FREQUENCY (MHz)	FREQUENCY (MHz)	FREQUENCY (GHz)
0.090-0.110	16.42-16.423	399.9-410	4.5-5.15
0.495-0.505	16.69475-16.69525	608-614	5.35-5.46
2.1735-2.1905	16.80425-16.80475	960-1240	7.25-7.75
4.125-4.128	25.5-25.67	1300-1427	8.025-8.5
4.17725-4.17775	37.5-38.25	1435-1626.5	9.0-9.2
4.20725-4.20775	73-74.6	1645.5-1646.5	9.3-9.5
6.215-6.218	74.8-75.2	1660-1710	10.6-12.7
6.26775-6.26825	108-121.94	1718.8-1722.2	13.25-13.4
6.31175-6.31225	123-138	2200-2300	14.47-14.5
8.291-8.294	149.9-150.05	2310-2390	15.35-16.2
8.362-8.366	156.52475-156.52525	2483.5-2500	17.7-21.4
8.37625-8.38675	156.7-156.9	2690-2900	22.01-23.12
8.41425-8.41475	162.0125-167.17	3260-3267	23.6-24.0
12.29-12.293	167.72-173.2	3332-3339	31.2-31.8
12.51975-12.52025	240-285	3345.8-3358	36.43-36.5
12.57675-12.57725	322-335.4	3600-4400	Above 38.6
13.36-13.41			



For Radiated Emission	
Spectrum Parameter	Setting
Attenuation	Auto
Detector	Peak/QP/AV
Start Frequency	9 KHz/150KHz(Peak/QP/AV)
Stop Frequency	150KHz/30MHz(Peak/QP/AV)
RB / VB (emission in restricted band)	200Hz (From 9kHz to 0.15MHz)/
	9KHz (From 0.15MHz to 30MHz);
	200Hz (From 9kHz to 0.15MHz)/
	9KHz (From 0.15MHz to 30MHz)
Attenuation	Auto
Detector	Peak/QP
Start Frequency	30 MHz(Peak/QP)
Stop Frequency	1000 MHz (Peak/QP)
RB / VB (emission in restricted band)	120 KHz / 300 KHz
Attenuation	Auto
Detector	Peak/AV
Start Frequency	1000 MHz(Peak/AV)
Stop Frequency	10th carrier hamonic(Peak/AV)
RB / VB (emission in restricted band)	1 MHz / 3 MHz(Peak)
	1 MHz/1/T MHz(AVG)
For Restricted band	
Spectrum Parameter	Setting
Detector	Peak/AV
Start/Stop Frequency	Lower Band Edge: 2310 to 2410 MHz
	Upper Band Edge: 2476 to 2500 MHz
RB / VB	1 MHz / 3 MHz(Peak)
	1 MHz/1/T MHz(AVG)
Receiver Parameter	Setting
Attenuation	Auto
Start ~ Stop Frequency	9kHz~90kHz / RB 200Hz for PK & AV
Start ~ Stop Frequency	90kHz~110kHz / RB 200Hz for QP
Start ~ Stop Frequency	110kHz~490kHz / RB 200Hz for PK & AV
Start ~ Stop Frequency	490kHz~30MHz / RB 9kHz for QP
Start ~ Stop Frequency	30MHz~1000MHz / RB 120kHz for QP

### 3.2.2 Test Procedure

- a) The measuring distance of at 3 m shall be used for measurements at frequency 0.009MHz up to 1GHz, and above 1GHz.
- b) The EUT was placed on the top of a rotating table 0.8 meters (above 1GHz is 1.5 m) above the ground at a 3 meter anechoic chamber test site. The table was rotated 360 degrees to determine the position of the highest radiation.
- c) The height of the equipment shall be 0.8 m (above 1GHz is 1.5 m); the height of the test antenna shall vary between 1 m to 4 m. horizontal and vertical polarizations of the antenna are set to make the measurement.
- d) The initial step in collecting conducted emission data is a spectrum analyzer peak detector mode pre-scanning the measurement frequency range. Significant peaks are then marked and then QuasiPeak detector mode re-measured.
- e) If the Peak Mode measured value compliance with and lower than Quasi Peak Mode Limit, the EUT shall be deemed to meet QP Limits and then no additional QP Mode measurement performed.
- f) For the actual test configuration, please refer to the related Item –EUT Test Photos.

**Note:**

Both horizontal and vertical antenna polarities were tested and performed pretest to three orthogonal axis. The worst case emissions were reported.

### 3.2.3 Test Setup

#### a) Radiated Emission Test-Up Frequency Below 30MHz

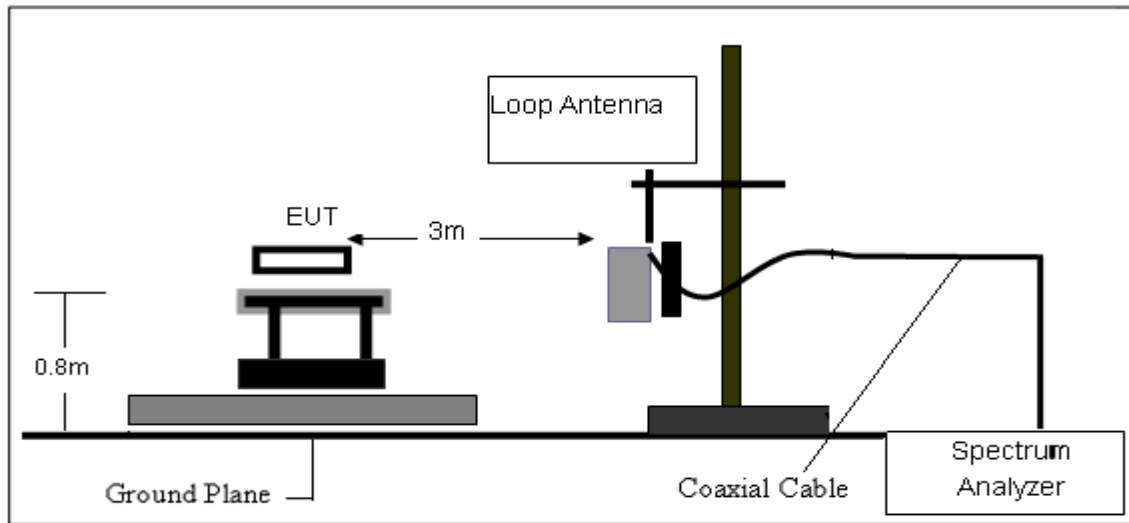

#### b) Radiated Emission Test-Up Frequency 30MHz~1GHz

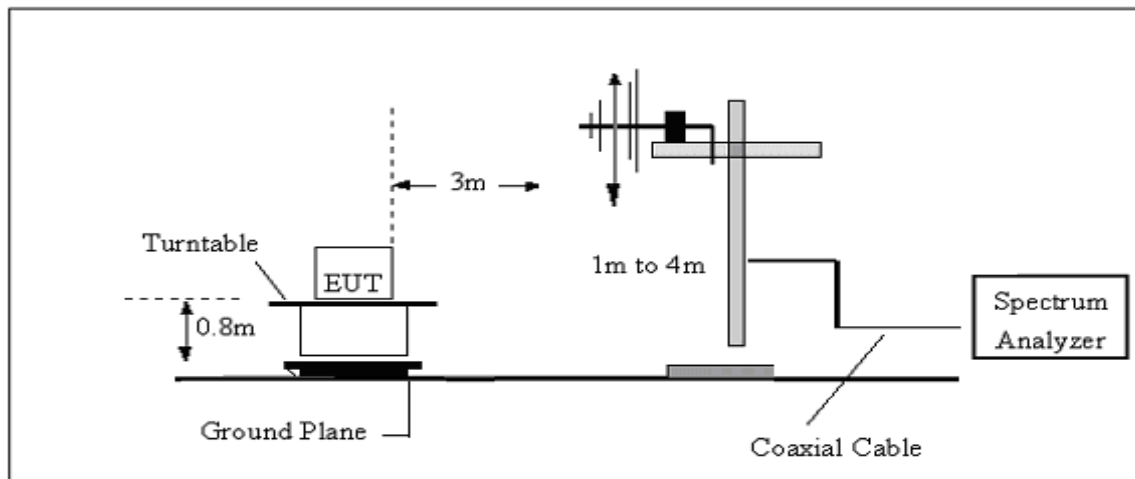

#### c) Radiated Emission Test-Up Frequency Above 1GHz

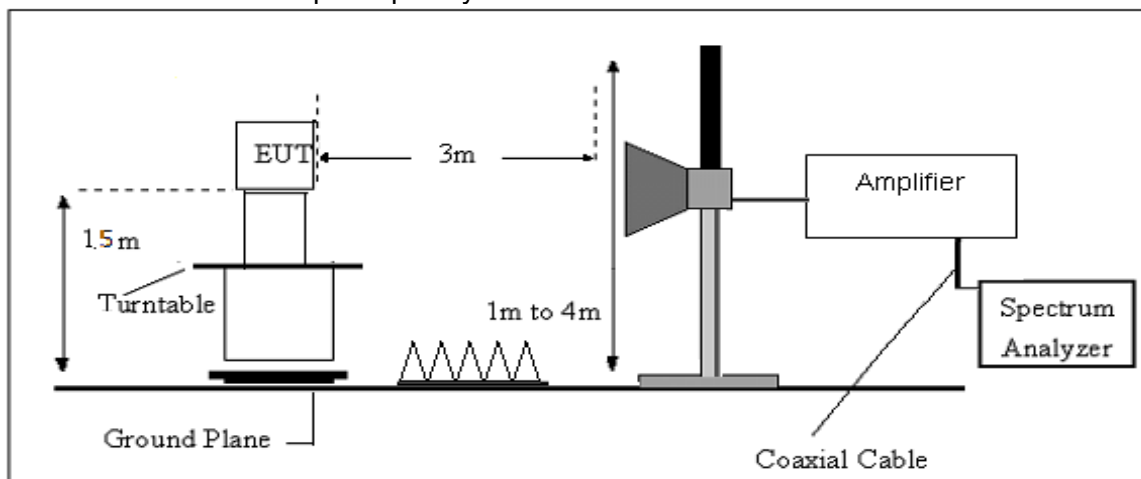



### 3.2.4 EUT Operating Conditions

The EUT tested system was configured as the statements of 2.5 Unless otherwise a special operating condition is specified in the follows during the testing.

### 3.2.5 Test Result

#### Field Strength Calculation

The field strength is calculated by adding the Antenna Factor and Cable Factor and subtracting the Amplifier Gain and Duty Cycle Correction Factor (if any) from the measured reading. The basic equation with a sample calculation is as follows:

$$FS = RA + AF + CL - AG$$

Where

FS = Field Strength

CL = Cable Attenuation Factor (Cable Loss)

RA = Reading Amplitude

AG = Amplifier Gain

AF = Antenna Factor

For example:

Frequency (MHz)	FS (dB $\mu$ V/m)	RA (dB $\mu$ V/m)	AF (dB)	CL (dB)	AG (dB)	Factor (dB)
300	40	58.1	12.2	1.6	31.9	-18.1

Factor=AF+CL-AG

9KHz-30MHz							
Temperature:		/		Relative Humidity:		/	
Test Voltage:		/		Test Mode:		TX Mode	
TX Mode							
Freq.	Reading	Limit	Margin	State	Test Result		
(MHz)	(dB $\mu$ V/m)	(dB $\mu$ V/m)	(dB)	P/F			
--	--	--	--	--	/		
--	--	--	--	--	/		

Note:

The amplitude of spurious emissions which are attenuated by more than 20dB below the permissible value has no need to be reported.

Distance extrapolation factor =40 log (specific distance/test distance)(dB);

Limit line = specific limits (dB $\mu$ v) + distance extrapolation factor.

## Low Channel (802.11 n20/ 5180 MHz)

Below 1GHz							
Temperature:		26.3°C		Relative Humidity:		59%	
Test Voltage:		230V 50Hz		Phase:		Horizontal	
Test Mode:		Mode 1 Low					
No.	Frequency	Reading	Correct	Result	Limit	Margin	Remark
	(MHz)	(dBuV)	Factor(dB)	(dBuV)	(dBuV)	(dB)	
1	183.8660	45.44	-12.26	33.18	43.50	-10.32	Pass
2	235.1346	48.66	-11.15	37.51	46.00	-8.49	Pass
3	282.2701	52.61	-11.59	41.02	46.00	-4.98	Pass
4	322.5896	50.27	-10.43	39.84	46.00	-6.16	Pass
5	723.7930	36.19	-2.34	33.85	46.00	-12.15	Pass
6	956.4741	43.46	1.42	44.88	54.00	-9.12	Pass

Below 1GHz							
Temperature:		26.3°C		Relative Humidity:		59%	
Test Voltage:		230V 50Hz		Phase:		Vertical	
Test Mode:		Mode 1 Low					
No.	Frequency	Reading	Correct	Result	Limit	Margin	Remark
	(MHz)	(dBuV)	Factor(dB)	(dBuV)	(dBuV)	(dB)	
1	51.9000	38.76	-10.70	28.06	40.00	-11.94	Pass
2	144.7898	51.90	-12.01	39.89	43.50	-3.61	Pass
3	183.8660	51.36	-12.26	39.10	43.50	-4.40	Pass
4	284.2606	51.19	-11.51	39.68	46.00	-6.32	Pass
5	327.1553	46.61	-10.32	36.29	46.00	-9.71	Pass
6	569.9687	40.71	-5.29	35.42	46.00	-10.58	Pass

## Remark:

1. Margin = Result (Result = Reading + Factor) - Limit
2. Factor = Antenna Factor + Cable Loss - Pre-amplifier.
3. The frequency emission of peak points that did not show above the forms are at least 20dB below the limit, the frequency emission is mainly from the environment noise.
4. Pre-scan both the SISO and MIMO mode, only the worst-case results were reported.

## Mid Channel (802.11 n20/ 5200MHz)

Below 1GHz							
Temperature:		26.3°C		Relative Humidity:		59%	
Test Voltage:		230V 50Hz		Phase:		Horizontal	
Test Mode:		Mode 1 Mid					
No.	Frequency	Reading	Correct	Result	Limit	Margin	Remark
	(MHz)	(dBuV)	Factor(dB)	(dBuV)	(dBuV)	(dB)	
1	186.4684	43.38	-12.41	30.97	43.50	-12.53	Pass
2	233.4881	46.50	-11.26	35.24	46.00	-10.76	Pass
3	280.2936	52.95	-11.67	41.28	46.00	-4.72	Pass
4	338.8546	52.09	-10.08	42.01	46.00	-3.99	Pass
5	723.7930	35.86	-2.34	33.52	46.00	-12.48	Pass
6	965.4741	43.70	1.42	45.12	54.00	-8.88	Pass

Below 1GHz							
Temperature:		26.3°C		Relative Humidity:		59%	
Test Voltage:		230V 50Hz		Phase:		Vertical	
Test Mode:		Mode 1 Mid					
No.	Frequency	Reading	Correct	Result	Limit	Margin	Remark
	(MHz)	(dBuV)	Factor(dB)	(dBuV)	(dBuV)	(dB)	
1	144.7898	51.89	-12.01	39.88	43.50	-3.62	Pass
2	186.4684	50.82	-12.41	38.41	43.50	-5.09	Pass
3	282.2701	53.75	-11.59	42.16	46.00	-3.84	Pass
4	502.2472	45.91	-6.27	39.64	46.00	-6.36	Pass
5	569.9687	41.76	-5.29	36.47	46.00	-9.53	Pass
6	965.4741	37.10	1.42	38.52	54.00	-15.48	Pass

## Remark:

1. Margin = Result (Result = Reading + Factor) - Limit
2. Factor = Antenna Factor + Cable Loss - Pre-amplifier.
3. The frequency emission of peak points that did not show above the forms are at least 20dB below the limit, the frequency emission is mainly from the environment noise.
4. Pre-scan both the SISO and MIMO mode, only the worst-case results were reported.

High Channel (802.11 n20/ 5240 MHz)

Below 1GHz							
Temperature:		26.3°C		Relative Humidity:		59%	
Test Voltage:		230V 50Hz		Phase:		Horizontal	
Test Mode:		Mode 1 High					
No.	Frequency	Reading	Correct	Result	Limit	Margin	Remark
	(MHz)	(dBuV)	Factor(dB)	(dBuV)	(dBuV)	(dB)	
1	185.1624	43.57	-12.33	31.24	43.50	-12.26	Pass
2	235.1346	48.77	-11.15	37.62	46.00	-8.38	Pass
3	280.2936	52.93	-11.67	41.26	46.00	-4.74	Pass
4	324.8645	50.24	-10.38	39.86	46.00	-6.14	Pass
5	723.7930	37.75	-2.34	35.41	46.00	-10.59	Pass
6	965.4741	43.43	1.42	44.85	54.00	-9.15	Pass

Below 1GHz							
Temperature:		26.3°C		Relative Humidity:		59%	
Test Voltage:		230V 50Hz		Phase:		Vertical	
Test Mode:		Mode 1 High					
No.	Frequency	Reading	Correct	Result	Limit	Margin	Remark
	(MHz)	(dBuV)	Factor(dB)	(dBuV)	(dBuV)	(dB)	
1	54.1350	38.62	-10.93	27.69	40.00	-12.31	Pass
2	144.7898	51.16	-12.01	39.15	43.50	-4.35	Pass
3	186.4684	50.95	-12.41	38.54	43.50	-4.96	Pass
4	280.2936	51.13	-11.67	39.46	46.00	-6.54	Pass
5	573.9882	42.86	-5.24	37.62	46.00	-8.38	Pass
6	965.4741	36.79	1.42	38.21	54.00	-15.79	Pass

Remark:

1. Margin = Result (Result = Reading + Factor) – Limit
2. Factor = Antenna Factor + Cable Loss – Pre-amplifier.
3. The frequency emission of peak points that did not show above the forms are at least 20dB below the limit, the frequency emission is mainly from the environment noise.
4. Pre-scan both the SISO and MIMO mode, only the worst-case results were reported.

## Low Channel (802.11 n20/ 5745 MHz)

Below 1GHz							
Temperature:		26.3°C		Relative Humidity:		59%	
Test Voltage:		230V 50Hz		Phase:		Horizontal	
Test Mode:		Mode 2 Low					
No.	Frequency	Reading	Correct	Result	Limit	Margin	Remark
	(MHz)	(dBuV)	Factor(dB)	(dBuV)	(dBuV)	(dB)	
1	183.8660	43.46	-12.26	31.20	43.50	-12.30	Pass
2	233.4881	47.50	-11.26	36.24	46.00	-9.76	Pass
3	280.2936	52.93	-11.67	41.26	46.00	-4.74	Pass
4	324.8645	53.75	-10.38	43.37	46.00	-2.63	Pass
5	723.7930	37.77	-2.34	35.43	46.00	-10.57	Pass
6	965.4741	41.36	1.42	42.78	54.00	-11.22	Pass

Below 1GHz							
Temperature:		26.3°C		Relative Humidity:		59%	
Test Voltage:		230V 50Hz		Phase:		Vertical	
Test Mode:		Mode 2 Low					
No.	Frequency	Reading	Correct	Result	Limit	Margin	Remark
	(MHz)	(dBuV)	Factor(dB)	(dBuV)	(dBuV)	(dB)	
1	144.7898	51.88	-12.01	39.87	43.50	-3.63	Pass
2	185.1625	50.48	-12.33	38.15	43.50	-5.35	Pass
3	280.2936	51.13	-11.67	39.46	46.00	-6.54	Pass
4	327.1553	45.50	-10.32	35.18	46.00	-10.82	Pass
5	573.9882	41.35	-5.24	36.11	46.00	-9.89	Pass
6	965.4741	38.20	1.42	39.62	54.00	-14.38	Pass

## Remark:

1. Margin = Result (Result = Reading + Factor) - Limit
2. Factor = Antenna Factor + Cable Loss - Pre-amplifier.
3. The frequency emission of peak points that did not show above the forms are at least 20dB below the limit, the frequency emission is mainly from the environment noise.
4. Pre-scan both the SISO and MIMO mode, only the worst-case results were reported.

## Mid Channel (802.11 n20/ 5785MHz)

Below 1GHz							
Temperature:		26.3°C		Relative Humidity:		59%	
Test Voltage:		230V 50Hz		Phase:		Horizontal	
Test Mode:		Mode 2 Mid					
No.	Frequency	Reading	Correct	Result	Limit	Margin	Remark
	(MHz)	(dBuV)	Factor(dB)	(dBuV)	(dBuV)	(dB)	
1	185.1624	44.01	-12.33	31.68	43.50	-11.82	Pass
2	235.1346	46.39	-11.15	35.24	46.00	-10.76	Pass
3	282.2701	53.69	-11.59	42.10	46.00	-3.90	Pass
4	324.8645	49.33	-10.38	38.95	46.00	-7.05	Pass
5	723.7930	35.63	-2.34	33.29	46.00	-12.71	Pass
6	965.4741	43.60	1.42	45.02	54.00	-8.98	Pass

Below 1GHz							
Temperature:		26.3°C		Relative Humidity:		59%	
Test Voltage:		230V 50Hz		Phase:		Vertical	
Test Mode:		Mode 2 Mid					
No.	Frequency	Reading	Correct	Result	Limit	Margin	Remark
	(MHz)	(dBuV)	Factor(dB)	(dBuV)	(dBuV)	(dB)	
1	144.7898	51.85	-12.01	39.84	43.50	-3.66	Pass
2	185.1625	50.79	-12.33	38.46	43.50	-5.04	Pass
3	282.2701	50.59	-11.59	39.00	46.00	-7.00	Pass
4	324.8645	45.66	-10.38	35.28	46.00	-10.72	Pass
5	569.9687	42.81	-5.29	37.52	46.00	-8.48	Pass
6	965.4741	38.71	1.42	40.13	54.00	-13.87	Pass

## Remark:

1. Margin = Result (Result = Reading + Factor) – Limit
2. Factor = Antenna Factor + Cable Loss – Pre-amplifier.
3. The frequency emission of peak points that did not show above the forms are at least 20dB below the limit, the frequency emission is mainly from the environment noise.
4. Pre-scan both the SISO and MIMO mode, only the worst-case results were reported.

High Channel (802.11 n20/ 5825 MHz)

Below 1GHz							
Temperature:		26.3°C		Relative Humidity:		59%	
Test Voltage:		230V 50Hz		Phase:		Horizontal	
Test Mode:		Mode 2 High					
No.	Frequency	Reading	Correct	Result	Limit	Margin	Remark
	(MHz)	(dBuV)	Factor(dB)	(dBuV)	(dBuV)	(dB)	
1	183.8660	43.82	-12.26	31.56	43.50	-11.94	Pass
2	235.1346	48.69	-11.15	37.54	46.00	-8.46	Pass
3	282.2701	51.74	-11.59	40.15	46.00	-5.85	Pass
4	324.8645	48.99	-10.38	38.61	46.00	-7.39	Pass
5	723.7930	35.63	-2.34	33.29	46.00	-12.71	Pass
6	965.4741	43.46	1.42	44.88	54.00	-9.12	Pass

Below 1GHz							
Temperature:		26.3°C		Relative Humidity:		59%	
Test Voltage:		230V 50Hz		Phase:		Vertical	
Test Mode:		Mode 2 High					
No.	Frequency	Reading	Correct	Result	Limit	Margin	Remark
	(MHz)	(dBuV)	Factor(dB)	(dBuV)	(dBuV)	(dB)	
1	144.7898	46.83	-12.01	34.82	43.50	-8.68	Pass
2	185.1625	50.74	-12.33	38.41	43.50	-5.09	Pass
3	280.2936	51.31	-11.67	39.64	46.00	-6.36	Pass
4	498.7302	46.18	-6.33	39.85	46.00	-6.15	Pass
5	578.0357	41.43	-5.18	36.25	46.00	-9.75	Pass
6	965.4741	38.09	1.42	39.51	54.00	-14.49	Pass

Remark:

1. Margin = Result (Result = Reading + Factor) – Limit
2. Factor = Antenna Factor + Cable Loss – Pre-amplifier.
3. The frequency emission of peak points that did not show above the forms are at least 20dB below the limit, the frequency emission is mainly from the environment noise.
4. Pre-scan both the SISO and MIMO mode, only the worst-case results were reported.



Low Channel (802.11 n20/ 5180 MHz)

Above 1GHz							
Temperature:		26.3°C		Relative Humidity:		59%	
Test Voltage:		230V 50Hz		Phase:		Horizontal	
Test Mode:		Mode 3					
No.	Frequency	Reading	Correct	Result	Limit	Margin	Remark
	(MHz)	(dBuV)	Factor(dB)	(dBuV)	(dBuV)	(dB)	
1	1116.3386	48.84	-3.64	45.20	74.00	-28.80	Pass
2	1116.3386	30.31	-3.64	26.67	54.00	-27.33	Pass
3	5181.1197	40.68	11.90	52.58	74.00	-21.42	Pass
4	5181.1197	30.25	11.90	42.15	54.00	-11.85	Pass
5	6272.4561	37.60	14.73	52.33	74.00	-21.67	Pass
6	6272.4561	15.95	14.73	30.68	54.00	-23.32	Pass
7	6881.5594	36.80	16.68	53.48	74.00	-20.52	Pass
8	6881.5594	21.93	16.68	38.61	54.00	-15.39	Pass
9	8930.7471	34.16	18.65	52.81	74.00	-21.19	Pass
10	8930.7471	19.29	18.65	37.94	54.00	-16.06	Pass
11	13318.7217	27.19	25.90	53.09	74.00	-20.91	Pass
12	13318.7217	4.78	25.90	30.68	54.00	-23.32	Pass

Above 1GHz							
Temperature:		26.3°C		Relative Humidity:		59%	
Test Voltage:		230V 50Hz		Phase:		Vertical	
Test Mode:		Mode 3					
No.	Frequency	Reading	Correct	Result	Limit	Margin	Remark
	(MHz)	(dBuV)	Factor(dB)	(dBuV)	(dBuV)	(dB)	
1	1260.7327	48.12	-2.61	45.51	74.00	-28.49	Pass
2	1260.7327	28.53	-2.61	25.92	54.00	-28.08	Pass
3	5004.1481	39.12	11.82	50.94	74.00	-23.06	Pass
4	5004.1481	19.27	11.82	31.09	54.00	-22.91	Pass
5	5953.8441	37.29	14.30	51.59	74.00	-22.41	Pass
6	5953.8441	16.27	14.30	30.57	54.00	-23.43	Pass
7	6841.8144	36.06	16.36	52.42	74.00	-21.58	Pass
8	6841.8144	20.82	16.36	37.18	54.00	-16.82	Pass
9	10203.4264	31.63	21.30	52.93	74.00	-21.07	Pass
10	10203.4264	16.55	21.30	37.85	54.00	-16.15	Pass
11	11793.3027	28.79	25.13	53.92	74.00	-20.08	Pass
12	11793.3027	13.84	25.13	38.97	54.00	-15.03	Pass

Remark:

1. Margin = Result (Result =Reading + Factor )–Limit
2. Factor = Antenna Factor + Cable Loss – Pre-amplifier.
3. The frequency emission of peak points that did not show above the forms are at least 20dB below the limit, the frequency emission is mainly from the environment noise.
4. Pre-scan both the SISO and MIMO mode, only the worst-case results were reported.



## Mid Channel (802.11 n20/ 5200 MHz)

Above 1GHz							
Temperature:		26.3°C		Relative Humidity:		59%	
Test Voltage:		230V 50Hz		Phase:		Horizontal	
Test Mode:		Mode 3					
No.	Frequency (MHz)	Reading (dBuV)	Correct Factor(dB)	Result (dBuV)	Limit (dBuV)	Margin (dB)	Remark
1	1260.7327	48.41	-2.61	45.80	74.00	-28.20	Pass
2	1260.7327	29.55	-2.61	26.94	54.00	-27.06	Pass
3	4975.2462	40.89	11.45	52.34	74.00	-21.66	Pass
4	4975.2462	19.80	11.45	31.25	54.00	-22.75	Pass
5	6272.4561	38.41	14.73	53.14	74.00	-20.86	Pass
6	6272.4561	16.84	14.73	31.57	54.00	-22.43	Pass
7	6961.7434	37.23	16.42	53.65	74.00	-20.35	Pass
8	6961.7434	21.99	16.42	38.41	54.00	-15.59	Pass
9	9518.2942	32.73	20.65	53.38	74.00	-20.62	Pass
10	9518.2942	17.56	20.65	38.21	54.00	-15.79	Pass
11	13473.9117	27.49	26.29	53.78	74.00	-20.22	Pass
12	13473.9117	11.65	26.29	37.94	54.00	-16.06	Pass

Above 1GHz							
Temperature:		26.3°C		Relative Humidity:		59%	
Test Voltage:		230V 50Hz		Phase:		Vertical	
Test Mode:		Mode 3					
No.	Frequency (MHz)	Reading (dBuV)	Correct Factor(dB)	Result (dBuV)	Limit (dBuV)	Margin (dB)	Remark
1	1260.7327	48.41	-2.61	45.80	74.00	-28.20	Pass
2	1260.7327	29.45	-2.61	26.84	54.00	-27.16	Pass
3	4975.2462	40.89	11.45	52.34	74.00	-21.66	Pass
4	4975.2462	20.37	11.45	31.82	54.00	-22.18	Pass
5	6961.7434	37.73	16.42	54.15	74.00	-19.85	Pass
6	6961.7434	19.52	16.42	35.94	54.00	-18.06	Pass
7	7637.7816	34.24	17.70	51.94	74.00	-22.06	Pass
8	7637.7816	14.88	17.70	32.58	54.00	-21.42	Pass
9	12496.5810	28.12	25.23	53.35	74.00	-20.65	Pass
10	12496.5810	13.24	25.23	38.47	54.00	-15.53	Pass
11	14782.3307	29.55	24.22	53.77	74.00	-20.23	Pass
12	14782.3307	14.72	24.22	38.94	54.00	-15.06	Pass

## Remark:

- Margin = Result (Result = Reading + Factor) – Limit
- Factor = Antenna Factor + Cable Loss – Pre-amplifier.
- The frequency emission of peak points that did not show above the forms are at least 20dB below the limit, the frequency emission is mainly from the environment noise.
- Pre-scan both the SISO and MIMO mode, only the worst-case results were reported.

## High Channel (802.11 n20/ 5240 MHz)

Above 1GHz							
Temperature:		26.3°C		Relative Humidity:		59%	
Test Voltage:		230V 50Hz		Phase:		Horizontal	
Test Mode:		Mode 3					
No.	Frequency (MHz)	Reading (dBuV)	Correct Factor(dB)	Result (dBuV)	Limit (dBuV)	Margin (dB)	Remark
1	2398.0156	41.54	3.88	45.42	74.00	-28.58	Pass
2	2398.0156	25.98	3.88	29.86	54.00	-24.14	Pass
3	4975.2462	30.31	11.45	41.76	54.00	-12.24	Pass
4	4975.2463	40.07	11.45	51.52	74.00	-22.48	Pass
5	7816.8095	21.38	17.58	38.96	54.00	-15.04	Pass
6	7816.8096	33.10	17.58	50.68	74.00	-23.32	Pass
7	9573.5871	30.26	20.85	51.11	74.00	-22.89	Pass
8	9573.5871	11.79	20.85	32.64	54.00	-21.36	Pass
9	12069.7352	27.15	25.35	52.50	74.00	-21.50	Pass
10	12069.7352	6.17	25.35	31.52	54.00	-22.48	Pass
11	14696.9542	28.50	24.72	53.22	74.00	-20.78	Pass
12	14696.9542	6.57	24.72	31.29	54.00	-22.71	Pass

Above 1GHz							
Temperature:		26.3°C		Relative Humidity:		59%	
Test Voltage:		230V 50Hz		Phase:		Vertical	
Test Mode:		Mode 3					
No.	Frequency (MHz)	Reading (dBuV)	Correct Factor(dB)	Result (dBuV)	Limit (dBuV)	Margin (dB)	Remark
1	1260.7327	47.51	-2.61	44.90	74.00	-29.10	Pass
2	1260.7327	29.54	-2.61	26.93	54.00	-27.07	Pass
3	5004.1481	39.56	11.82	51.38	74.00	-22.62	Pass
4	5004.1481	19.27	11.82	31.09	54.00	-22.91	Pass
5	6881.5594	37.85	16.68	54.53	74.00	-19.47	Pass
6	6881.5594	21.13	16.68	37.81	54.00	-16.19	Pass
7	9518.2942	32.67	20.65	53.32	74.00	-20.68	Pass
8	9518.2942	10.92	20.65	31.57	54.00	-22.43	Pass
9	10442.5928	33.41	20.39	53.80	74.00	-20.20	Pass
10	10442.5928	18.22	20.39	38.61	54.00	-15.39	Pass
11	13552.1834	28.52	25.73	54.25	74.00	-19.75	Pass
12	13552.1834	13.24	25.73	38.97	54.00	-15.03	Pass

## Remark:

1. Margin = Result (Result = Reading + Factor) – Limit
2. Factor = Antenna Factor + Cable Loss – Pre-amplifier.
3. The frequency emission of peak points that did not show above the forms are at least 20dB below the limit, the frequency emission is mainly from the environment noise.
4. Pre-scan both the SISO and MIMO mode, only the worst-case results were reported.



Low Channel (802.11 n20/ 5745 MHz)

Above 1GHz							
Temperature:		26.3°C		Relative Humidity:		59%	
Test Voltage:		230V 50Hz		Phase:		Horizontal	
Test Mode:		Mode 3					
No.	Frequency (MHz)	Reading (dBuV)	Correct Factor(dB)	Result (dBuV)	Limit (dBuV)	Margin (dB)	Remark
1	1535.1564	46.76	-1.49	45.27	74.00	-28.73	Pass
2	1535.1564	28.46	-1.49	26.97	54.00	-27.03	Pass
3	5004.1481	40.33	11.82	52.15	74.00	-21.85	Pass
4	5004.1481	20.74	11.82	32.56	54.00	-21.44	Pass
5	6272.4561	38.40	14.73	53.13	74.00	-20.87	Pass
6	6272.4561	16.51	14.73	31.24	54.00	-22.76	Pass
7	7002.1851	37.30	16.17	53.47	74.00	-20.53	Pass
8	7002.1851	20.67	16.17	36.84	54.00	-17.16	Pass
9	10085.9053	32.44	20.49	52.93	74.00	-21.07	Pass
10	10085.9053	17.02	20.49	37.51	54.00	-16.49	Pass
11	14868.2032	28.81	24.62	53.43	74.00	-20.57	Pass
12	14868.2032	13.38	24.62	38.00	54.00	-16.00	Pass

Above 1GHz							
Temperature:		26.3°C		Relative Humidity:		59%	
Test Voltage:		230V 50Hz		Phase:		Vertical	
Test Mode:		Mode 3					
No.	Frequency (MHz)	Reading (dBuV)	Correct Factor(dB)	Result (dBuV)	Limit (dBuV)	Margin (dB)	Remark
1	1253.4510	47.58	-2.59	44.99	74.00	-29.01	Pass
2	1253.4510	28.20	-2.59	25.61	54.00	-28.39	Pass
3	5004.1481	39.16	11.82	50.98	74.00	-23.02	Pass
4	5004.1481	19.00	11.82	30.82	54.00	-23.18	Pass
5	6532.0074	37.71	15.70	53.41	74.00	-20.59	Pass
6	6532.0074	22.78	15.70	38.48	54.00	-15.52	Pass
7	7549.8110	34.50	17.96	52.46	74.00	-21.54	Pass
8	7549.8110	12.61	17.96	30.57	54.00	-23.43	Pass
9	10085.9053	32.22	20.49	52.71	74.00	-21.29	Pass
10	10085.9053	17.00	20.49	37.49	54.00	-16.51	Pass
11	13473.9117	27.73	26.29	54.02	74.00	-19.98	Pass
12	13473.9117	13.16	26.29	39.45	54.00	-14.55	Pass

Remark:

1. Margin = Result (Result =Reading + Factor )–Limit
2. Factor = Antenna Factor + Cable Loss – Pre-amplifier.
3. The frequency emission of peak points that did not show above the forms are at least 20dB below the limit, the frequency emission is mainly from the environment noise.
4. Pre-scan both the SISO and MIMO mode, only the worst-case results were reported.



Mid Channel (802.11 n20/ 5785 MHz)

Above 1GHz							
Temperature:		26.3°C		Relative Humidity:		59%	
Test Voltage:		230V 50Hz		Phase:		Horizontal	
Test Mode:		Mode 3					
No.	Frequency (MHz)	Reading (dBuV)	Correct Factor(dB)	Result (dBuV)	Limit (dBuV)	Margin (dB)	Remark
1	5004.1481	40.82	11.82	52.64	74.00	-21.36	Pass
2	5004.1481	20.72	11.82	32.54	54.00	-21.46	Pass
3	6272.4561	38.05	14.73	52.78	74.00	-21.22	Pass
4	6272.4561	16.95	14.73	31.68	54.00	-22.32	Pass
5	6961.7434	36.62	16.42	53.04	74.00	-20.96	Pass
6	6961.7434	21.47	16.42	37.89	54.00	-16.11	Pass
7	9969.7378	32.89	20.96	53.85	74.00	-20.15	Pass
8	9969.7378	17.56	20.96	38.52	54.00	-15.48	Pass
9	12863.7942	29.07	24.23	53.30	74.00	-20.70	Pass
10	12863.7942	6.36	24.23	30.59	54.00	-23.41	Pass
11	14696.9542	28.87	24.72	53.59	74.00	-20.41	Pass
12	14696.9542	13.92	24.72	38.64	54.00	-15.36	Pass

Above 1GHz							
Temperature:		26.3°C		Relative Humidity:		59%	
Test Voltage:		230V 50Hz		Phase:		Vertical	
Test Mode:		Mode 3					
No.	Frequency (MHz)	Reading (dBuV)	Correct Factor(dB)	Result (dBuV)	Limit (dBuV)	Margin (dB)	Remark
1	5004.1481	39.57	11.82	51.39	74.00	-22.61	Pass
2	5004.1481	18.70	11.82	30.52	54.00	-23.48	Pass
3	6881.5594	35.89	16.68	52.57	74.00	-21.43	Pass
4	6881.5594	15.29	16.68	31.97	54.00	-22.03	Pass
5	8982.6270	34.08	18.87	52.95	74.00	-21.05	Pass
6	8982.6270	18.61	18.87	37.48	54.00	-16.52	Pass
7	11390.4790	29.56	23.60	53.16	74.00	-20.84	Pass
8	11390.4790	9.04	23.60	32.64	54.00	-21.36	Pass
9	13013.6834	29.71	24.36	54.07	74.00	-19.93	Pass
10	13013.6834	15.49	24.36	39.85	54.00	-14.15	Pass
11	14696.9542	29.84	24.72	54.56	74.00	-19.44	Pass
12	14696.9542	15.13	24.72	39.85	54.00	-14.15	Pass

Remark:

1. Margin = Result (Result =Reading + Factor )–Limit
2. Factor = Antenna Factor + Cable Loss – Pre-amplifier.
3. The frequency emission of peak points that did not show above the forms are at least 20dB below the limit, the frequency emission is mainly from the environment noise.
4. Pre-scan both the SISO and MIMO mode, only the worst-case results were reported.

## High Channel (802.11 n20/ 5825 MHz)

Above 1GHz							
Temperature:		26.3°C		Relative Humidity:		59%	
Test Voltage:		230V 50Hz		Phase:		Horizontal	
Test Mode:		Mode 3					
No.	Frequency (MHz)	Reading (dBuV)	Correct Factor(dB)	Result (dBuV)	Limit (dBuV)	Margin (dB)	Remark
1	1260.7327	48.12	-2.61	45.51	74.00	-28.49	Pass
2	1260.7327	28.65	-2.61	26.04	54.00	-27.96	Pass
3	2398.0156	42.66	3.88	46.54	74.00	-27.46	Pass
4	2398.0156	21.53	3.88	25.41	54.00	-28.59	Pass
5	5004.1481	39.98	11.82	51.80	74.00	-22.20	Pass
6	5004.1481	30.33	11.82	42.15	54.00	-11.85	Pass
7	6881.5594	36.57	16.68	53.25	74.00	-20.75	Pass
8	6881.5594	22.24	16.68	38.92	54.00	-15.08	Pass
9	9518.2942	33.18	20.65	53.83	74.00	-20.17	Pass
10	9518.2942	11.89	20.65	32.54	54.00	-21.46	Pass
11	11930.7185	29.65	24.99	54.64	74.00	-19.36	Pass
12	11930.7185	14.62	24.99	39.61	54.00	-14.39	Pass

Above 1GHz							
Temperature:		26.3°C		Relative Humidity:		59%	
Test Voltage:		230V 50Hz		Phase:		Vertical	
Test Mode:		Mode 3					
No.	Frequency (MHz)	Reading (dBuV)	Correct Factor(dB)	Result (dBuV)	Limit (dBuV)	Margin (dB)	Remark
1	5004.1481	39.00	11.82	50.82	74.00	-23.18	Pass
2	5004.1481	18.39	11.82	30.21	54.00	-23.79	Pass
3	6456.7731	36.67	15.50	52.17	74.00	-21.83	Pass
4	6456.7731	14.96	15.50	30.46	54.00	-23.54	Pass
5	7637.7816	34.68	17.70	52.38	74.00	-21.62	Pass
6	7637.7816	20.15	17.70	37.85	54.00	-16.15	Pass
7	9408.6643	32.99	20.39	53.38	74.00	-20.62	Pass
8	9408.6643	18.22	20.39	38.61	54.00	-15.39	Pass
9	11793.3027	28.02	25.13	53.15	74.00	-20.85	Pass
10	11793.3027	7.51	25.13	32.64	54.00	-21.36	Pass
11	15128.8256	29.98	23.48	53.46	74.00	-20.54	Pass
12	15128.8256	9.08	23.48	32.56	54.00	-21.44	Pass

## Remark:

- Margin = Result (Result = Reading + Factor) – Limit
- Factor = Antenna Factor + Cable Loss – Pre-amplifier.
- The frequency emission of peak points that did not show above the forms are at least 20dB below the limit, the frequency emission is mainly from the environment noise.
- Pre-scan both the SISO and MIMO mode, only the worst-case results were reported.

Restricted band Requirements  
**Band I 5150-5250MHz 802.11 n(HT20)-Low**  
 Horizontal  
 /

No.	Frequency (MHz)	Reading (dBuV)	Correct Factor(dB/m)	Result (dBuV/m)	Limit (dBuV/m)	Margin (dB)	Remark
1	5150.0000	36.86	11.49	48.35	74.00	-25.65	Pass
2	5150.0000	27.66	11.49	39.15	54.00	-14.85	Pass

Vertical  
 /

No.	Frequency (MHz)	Reading (dBuV)	Correct Factor(dB/m)	Result (dBuV/m)	Limit (dBuV/m)	Margin (dB)	Remark
1	5150.00	40.46	11.49	51.95	74.00	-22.05	Pass
2	5150.00	24.75	11.49	36.24	54.00	-17.76	Pass

**Band I 5150-5250MHz 802.11 n(HT20)-High**  
 Horizontal

No.	Frequency (MHz)	Reading (dBuV)	Correct Factor(dB/m)	Result (dBuV/m)	Limit (dBuV/m)	Margin (dB)	Remark
1	5350.0000	35.97	12.02	47.99	74.00	-26.01	Pass
2	5350.0000	24.96	12.02	36.98	54.00	-17.02	Pass

Vertical

No.	Frequency (MHz)	Reading (dBuV)	Correct Factor(dB/m)	Result (dBuV/m)	Limit (dBuV/m)	Margin (dB)	Remark
1	5350.0000	40.06	12.02	52.08	74.00	-21.92	Pass
2	5350.0000	25.39	12.02	37.41	54.00	-16.59	Pass

Note: 1. Pre-scan both the SISO and MIMO mode, only the worst-case results were reported.

Restricted band Requirements  
**Band III 5725-5850MHz**

Note: The main frequency is too far away from the restricted band and does not require testing.

## 4 RF CONDUCTED TEST

### 4.1 CONDUCTED SPURIOUS & BAND EDGE EMISSION

#### 4.1.1 Limit

Undesirable emission limits. Except as shown in paragraph (b)(7) of this section, the maximum emissions outside of the frequency bands of operation shall be attenuated in accordance with the following limits:

- (1) For transmitters operating in the 5.15-5.25 GHz band: All emissions outside of the 5.15-5.35 GHz band shall not exceed an e.i.r.p. of  $-27$  dBm/MHz.
- (2) For transmitters operating in the 5.25-5.35 GHz band: All emissions outside of the 5.15-5.35 GHz band shall not exceed an e.i.r.p. of  $-27$  dBm/MHz.
- (3) For transmitters operating in the 5.47-5.725 GHz band: All emissions outside of the 5.47-5.725 GHz band shall not exceed an e.i.r.p. of  $-27$  dBm/MHz.
- (4) For transmitters operating in the 5.725-5.85 GHz band:
  - (i) All emissions shall be limited to a level of  $-27$  dBm/MHz at 75 MHz or more above or below the band edge increasing linearly to 10 dBm/MHz at 25 MHz above or below the band edge, and from 25 MHz above or below the band edge increasing linearly to a level of 15.6 dBm/MHz at 5 MHz above or below the band edge, and from 5 MHz above or below the band edge increasing linearly to a level of 27 dBm/MHz at the band edge.

#### 4.1.2 Test Procedure

Spectrum Parameter	Setting
Detector	Peak
Start/Stop Frequency	30 MHz to 10th carrier harmonic
RB / VB (emission in restricted band)	1000 KHz/3000 KHz
Trace-Mode:	Max hold
For Band edge	
Spectrum Parameter	Setting
Detector	Peak
Start/Stop Frequency	Lower Band Edge: 5140 to 5775 MHz
	Upper Band Edge: 5230 to 5950 MHz
RB / VB (emission in restricted band)	1000 KHz/3000 KHz
Trace-Mode:	Max hold

#### 4.1.3 Test Setup

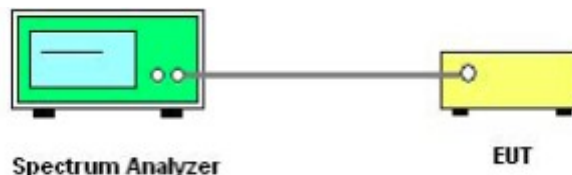

The EUT which is powered by the Battery, is coupled to the Spectrum Analyzer; the RF load attached to the EUT antenna terminal is 50Ohm; the path loss as the factor is calibrated to correct the reading.

Make the measurement with the spectrum analyzer's resolution bandwidth (RBW) = 1000 kHz. In order to make an accurate measurement, set the span greater than RBW.

#### **4.1.4 EUT Operating Conditions**

The EUT tested system was configured as the statements of 2.5 Unless otherwise a special operating condition is specified in the follows during the testing.

#### **4.1.5 Test Result**

Note:

1. Antenna 2 Power > Antenna 1 Power, Both antenna A and B have been test, Only show the worst data of Antenna B.
2. Data See Attachment A.



## 4.2 POWER SPECTRAL DENSITY TEST

### 4.2.1 Limit

1. For mobile and portable client devices in the 5.15-5.25 GHz band, , the maximum power spectral density shall not exceed 11 dBm in any 1 megahertz band. If transmitting antennas of directional gain greater than 6 dBi are used, both the maximum conducted output power and the maximum power spectral density shall be reduced by the amount in dB that the directional gain of the antenna exceeds 6 dBi.
2. For the 5.25-5.35 GHz and 5.47-5.725 GHz bands, the maximum power spectral density shall not exceed 11 dBm in any 1 megahertz band. If transmitting antennas of directional gain greater than 6 dBi are used, both the maximum conducted output power and the maximum power spectral density shall be reduced by the amount in dB that the directional gain of the antenna exceeds 6 dBi.
3. For the band 5.725-5.850 GHz, the peak power spectral density shall not exceed 30 dBm in any 500KHz band. If transmitting antenna directional gain is greater than 6 dBi, both the maximum conducted output power and the peak power spectral density shall be reduced by the amount in dB that the directional gain of the antenna exceeds 6 dBi.

### 4.2.2 Test Procedure

The setting follows Method SA-1 of FCC KDB 789033 D02 General U-NII Test Procedures New Rules v02r01. For devices operating in the band, the rules specify a measurement bandwidth of 500 kHz.

Many spectrum analyzers do not have 500 kHz RBW, thus a narrower RBW may need to be used. The rules permit the use of a RBWs less than 1 MHz, or 500 kHz, "provided that the measured power is integrated over the full reference bandwidth" to show the total power over the specified measurement bandwidth (i.e., 1 MHz, or 500 kHz). If measurements are performed using a reduced resolution bandwidth (< 1 MHz, or < 500 kHz) and integrated over 1 MHz, or 500 KHz bandwidth, the following adjustments to the procedures apply:

- a) Set  $RBW \geq 1/T$ , where T is defined in section II.B.I.a).
- b) Set  $VBW \geq 3 RBW$ .
- c) If measurement bandwidth of Maximum PSD is specified in 500 kHz, add  $10 \log(500\text{kHz}/RBW)$  to the measured result, whereas RBW (< 500 kHz) is the reduced resolution bandwidth of the spectrum analyzer set during measurement.
- d) If measurement bandwidth of Maximum PSD is specified in 1 MHz, add  $10 \log(1\text{MHz}/RBW)$  to the measured result, whereas RBW (< 1 MHz) is the reduced resolution bandwidth of spectrum analyzer set during measurement.
- e) Care must be taken to ensure that the measurements are performed during a period of continuous transmission or are corrected upward for duty cycle.

Note: As a practical matter, it is recommended to use reduced RBW of 100 kHz for the sections 5.c) and 5.d) above, since RBW=100 KHZ is available on nearly all spectrum analyzers.

### 4.2.3 Test Setup



### 4.2.4 EUT Operating Conditions

The EUT tested system was configured as the statements of 2.5 Unless otherwise a special operating condition is specified in the follows during the testing.

#### 4.2.5 Test Result

Temperature:	25.5°C	Relative Humidity:	58.0%
Test Mode:	Mode1,2	Test Voltage:	120V 60Hz

5150-5250MHz					
Frequency (MHz)	Direct measurement Ant_1 Power Density (dBm)	Direct measurement Ant_2 Power Density (dBm)	Power Density Total (dBm)	Limit (dBm)	Result
802.11n(HT20)					
5180	7.220	7.124	10.183	23.98	Pass
5200	7.47	7.397	10.441	23.98	Pass
5240	6.686	7.609	10.182	23.98	Pass

5725-5850MHz					
Frequency (MHz)	Direct measurement Ant_1 Power Density (dBm)	Direct measurement Ant_2 Power Density (dBm)	Power Density Total (dBm)	Limit (dBm)	Result
802.11n(HT20)					
5745	3.603	4.374	7.016	30	Pass
5785	4.089	3.153	6.656	30	Pass
5825	4.052	3.548	6.818	30	Pass

Note:

1. RB conversion formula= $10 * \text{LOG} (500\text{KHz} / \text{RBW})$ .
2. Data see Attachment A.

## 4.3 BANDWIDTH TEST

### 4.3.1 EMISSION BANDWIDTH (EBW) 26 BANDWID PROCEDURES

#### 4.3.1.1 Limit

The following procedure shall be used for measuring 26 bandwidth.

#### 4.3.1.2 Test Procedure

1. The testing follows FCC KDB 789033 D02 General UNII Test Procedures New Rules v02r01.
2. Set RBW = approximately 1% of the emission bandwidth.
3. Set the VBW  $\geq$  RBW.
4. Detector = Peak.
5. Trace mode = max hold.
6. Measure the maximum width of the emission that is 26 dB down from the peak of the emission. Compare this with the RBW setting of the analyzer. Readjust RBW and repeat measurement as needed until the RBW/EBW ratio is approximately 1%.

#### 4.3.1.3 Test Setup



#### 4.3.1.4 EUT Operating Conditions

The EUT tested system was configured as the statements of 2.5 Unless otherwise a special operating condition is specified in the follows during the testing.

**4.3.1.5 Test Result**

Temperature:	25.5°C	Relative Humidity:	58.0%
Test Mode:	Mode1	Test Voltage:	120V 60Hz

Frequency	26dB Bandwidth (MHz)	Result
802.11n(HT20)		
5180	22.16	Pass
5200	21.36	Pass
5240	21.94	Pass

Note: 1. Antenna 2 Power > Antenna 1 Power, Both antenna A and B have been test, Only show the worst data of Antenna B.

2. Data see Attachment A.

## 4.3.2 OCCUPIED BANDWIDTH ( 99%) TEST APPLIED PROCEDURES

### 4.3.2.1 Limit

The following procedure shall be used for measuring (99 %) power bandwidth.

### 4.3.2.2 Test Procedure

The testing follows FCC KDB 789033 D02 General UNII Test Procedures v02r01. The following procedure shall be used for measuring (99 %) power bandwidth:

1. Set center frequency to the nominal EUT channel center frequency.
2. Set span = 1.5 times to 5.0 times the OBW.
3. Set RBW = 1 % to 5 % of the OBW
4. Set VBW  $\geq 3 \cdot$  RBW
5. Video averaging is not permitted. Where practical, a sample detection and single sweep mode shall be used. Otherwise, peak detection and max hold mode (until the trace stabilizes) shall be used.
6. Use the 99 % power bandwidth function of the instrument (if available).
7. If the instrument does not have a 99 % power bandwidth function, the trace data points are recovered and directly summed in power units. The recovered amplitude data points, beginning at the lowest frequency, are placed in a running sum until 0.5 % of the total is reached; that frequency is recorded as the lower frequency. The process is repeated until 99.5 % of the total is reached; that frequency is recorded as the upper frequency. The 99% occupied bandwidth is the difference between these two frequencies.

### 4.3.2.3 Test Setup

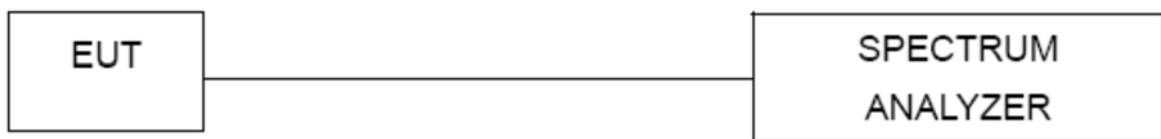

### 4.3.2.4 EUT Operating Conditions

The EUT tested system was configured as the statements of 2.5 Unless otherwise a special operating condition is specified in the follows during the testing.

**4.3.2.5 Test Result**

Temperature:	25.5°C	Relative Humidity:	58.0%
Test Mode:	Mode1,2	Test Voltage:	120V 60Hz

Frequency	99% Bandwidth (MHz)	Result
802.11n(HT20)		
5180	17.7133	Pass
5200	17.7010	Pass
5240	17.7377	Pass

Frequency	99% Bandwidth (MHz)	Result
802.11n(HT20)		
5745	17.5658	Pass
5785	17.5819	Pass
5825	17.6230	Pass

**Note:**

1. Antenna 2 Power > Antenna 1 Power, Both antenna A and B have been test, Only show the worst data of Antenna B.

2. Data see Attachment A.

### 4.3.3 EMISSION BANDWIDTH (EBW) 6 BANDWID PROCEDURES

#### 4.3.3.1 Limit

Section 15.407(e) specifies the minimum 6 dB emission bandwidth of at least 500 KHz for the band 5.725-5.85 GHz. The following procedure shall be used for measuring this bandwidth.

#### 4.3.3.2 Test Procedure

The testing follows FCC KDB 789033 D02 General UNII Test Procedures v02r01.

- a) Set RBW = 100 kHz.
- b) Set the video bandwidth (VBW)  $\geq 3 \times$  RBW.
- c) Detector = Peak.
- d) Trace mode = max hold.
- e) Sweep = auto couple.
- f) Allow the trace to stabilize.
- g) Measure the maximum width of the emission that is constrained by the frequencies associated with the two outermost amplitude points (upper and lower frequencies) that are attenuated by 6 dB relative to the maximum level measured in the fundamental emission.

#### 4.3.3.3 Test Setup

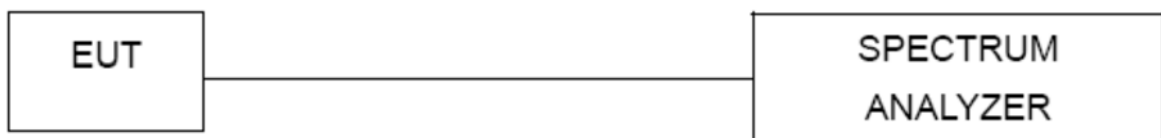

#### 4.3.3.4 EUT Operating Conditions

The EUT tested system was configured as the statements of 2.5 Unless otherwise a special operating condition is specified in the follows during the testing.

**4.3.3.5 Test Result**

Temperature:	25.5°C	Relative Humidity:	58.0%
Test Mode:	Mode 2	Test Voltage:	120V 60Hz

Frequency	6dB Bandwidth (MHz)	Result
802.11n(HT20)		
5745	17.57	Pass
5785	16.62	Pass
5825	16.65	Pass

**Note:**

1. Antenna 2 Power > Antenna 1 Power, Both antenna A and B have been test, Only show the worst data of Antenna B.
2. Data see Attachment A.



## 4.4 MAXIMUM CONDUCTED OUTPUT POWER

### 4.4.1 Limit

For mobile and portable client devices in the 5.15-5.25 GHz band, the maximum conducted output power over the frequency band of operation shall not exceed 250 mW provided the maximum antenna gain does not exceed 6 dBi. If transmitting antennas of directional gain greater than 6 dBi are used, both the maximum conducted output power and the maximum power spectral density shall be reduced by the amount in dB that the directional gain of the antenna exceeds 6 dBi.

For the 5.25-5.35 GHz and 5.47-5.725 GHz bands, the maximum conducted output power over the frequency bands of operation shall not exceed the lesser of 250 mW or  $11 \text{ dBm} + 10 \log B$ , where B is the 26 dB emission bandwidth in megahertz, if transmitting antennas of directional gain greater than 6 dBi are used.

For the band 5.725-5.85 GHz, the maximum conducted output power over the frequency band of operation shall not exceed 1 W. If transmitting antennas of directional gain greater than 6 dBi are used.

FCC Part 15.407, Subpart E				
Section	Test Item	Limit	Frequency Range (MHz)	Result
15.407(a) (1) (iv)	Peak Output Power	0.25 watt	5150-5250	PASS N/A PASS
		The lesser of 250 mW or $11 \text{ dBm} + 10 \log (26 \text{ dB emission bandwidth})$	5250-5350	
			5470-5725	
15.407(a) (3)		1 watt	5725-5825	

### 4.4.2 Test Procedure

The EUT was directly connected to the Power Sensor&PC

### 4.4.3 Test Setup

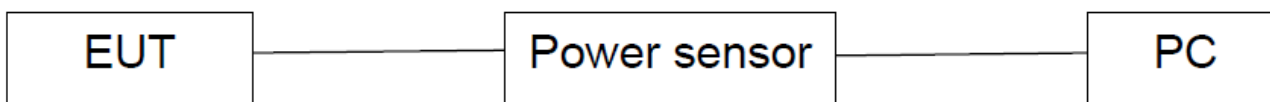

### 4.4.4 EUT Operating Conditions

The EUT tested system was configured as the statements of 2.5 Unless otherwise a special operating condition is specified in the follows during the testing.

**4.4.5 Test Result**

Temperature:	25.5°C	Relative Humidity:	58.0%
Test Mode:	Mode 1,2	Test Voltage:	120V 60Hz

5150-5250MHz						
Test Channel	Frequency (MHz)	Power ANT 1 (dBm)	Power ANT 2 (dBm)	Power Total (dBm)	Limit (dBm)	Result
802.11n(HT20)						
36	5180	10.00	10.22	13.12	24	Pass
40	5200	9.75	10.43	13.11	24	Pass
48	5240	9.20	10.40	12.85	24	Pass

5725-5850MHz						
Test Channel	Frequency (MHz)	Power ANT 1 (dBm)	Power ANT 2 (dBm)	Power Total (dBm)	Limit (dBm)	Result
802.11n(HT20)						
149	5745	9.94	10.15	13.06	30	Pass
157	5785	9.65	10.37	13.04	30	Pass
165	5825	9.12	10.32	12.77	30	Pass

Duty cycle				
5150-525MHz				
Mode	Tom(ms)	Tp(ms)	Duty cycle(%)	Duty factor(dB)
n20	0.09	100	99.91	0
5725-5850MHz				
Mode	Tom(ms)	Tp(ms)	Duty cycle(%)	Duty factor(dB)
n20	0.06	100	99.94	0

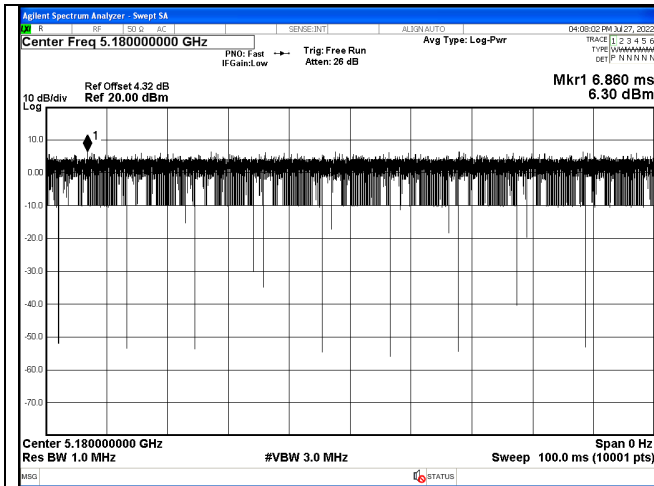

802.11n(HT20) 5180MHz

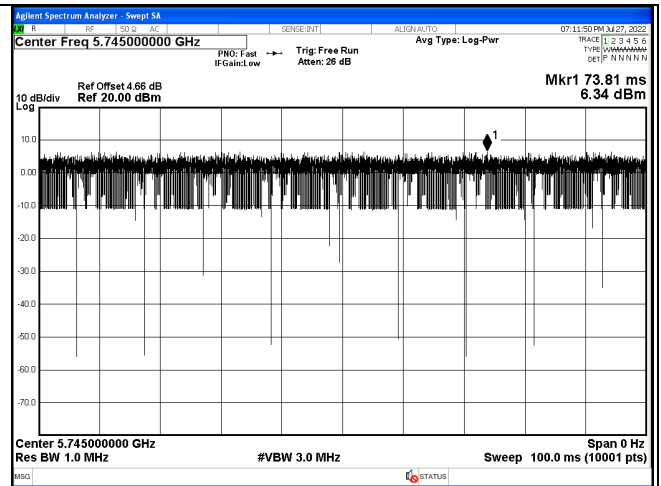

802.11n(HT20) 5745MHz

## **4.5 AUTOMATICALLY DISCONTINUE TRANSMISSION**

### **4.5.1 Limit**

The device shall automatically discontinue transmission in case of either absence of information to transmit or operational failure. These provisions are not intended to preclude the transmission of control or signaling information or the use of repetitive codes used by certain digital technologies to complete frame or burst intervals. Applicants shall include in their application for equipment authorization to describe how this requirement is met.

### **4.5.2 Test Result**

During no any information transmission, the EUT can automatically discontinue transmission and become standby mode for power saving. The EUT can detect the controlling signal of ACK message transmitting from remote device and verify whether it shall resend or discontinue transmission.

## 4.6 Antenna requirement

### 4.6.1 Limit

15.203 requirement: For intentional device, according to 15.203: an intentional radiator shall be designed to ensure that no antenna other than that furnished by the responsible party shall be used with the device.

### 4.6.2 Test Result

The EUT antenna is Portable Antenna. It uses non-standard SMA connectors and meets the standard requirements.

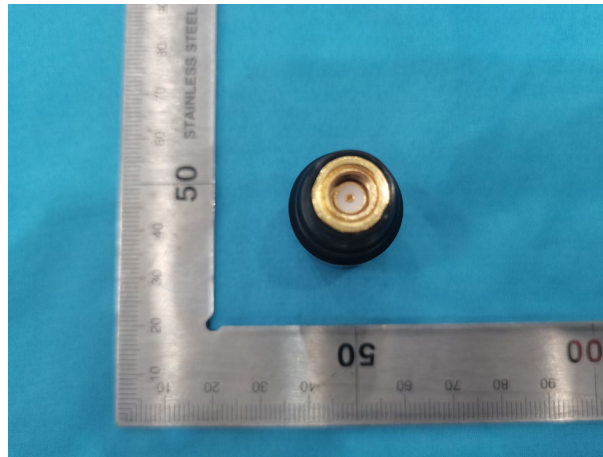

## 5 EUT PHOTOS

**Remark:** Please refer to EUT Photos Report\_C220711010-P02.

\*\*\*\*\***THE END**\*\*\*\*\*