



Shenzhen Huaxia Testing Technology Co., Ltd

1F., Block A of Tongsheng Technology Building, Huahui Road, Dalang Street, Longhua District, Shenzhen, China

Telephone: +86-755-26648640
Fax: +86-755-26648637
Website: www.cqa-cert.com

Report Template Version: V04
Report Template Revision Date: 2018-07-06

TEST REPORT

Report No.: CQASZ20201001255E-01
Applicant: Shenzhen Hollyland Technology Co., Ltd
Address of Applicant: 8F, Building 5D, Skyworth Innovation Valley, Tangtou Road. Shiyuan Street, Baoan District Shenzhen, China
Equipment Under Test (EUT):
EUT Name: WIRELESS MICROPHONE
Model No.: LARK 150, LARK 150 S, LARK 150 SE, LARK 150 Lite, LARK 150 PRO
Test Model No.: LARK 150
Brand Name: HOLLYLAND
FCC ID: 2ADZC-6901AR
Standards: 47 CFR Part 15, Subpart C
Date of Receipt: 2020-10-23
Date of Test: 2020-10-27 to 2020-11-17
Date of Issue: 2020-11-17
Test Result: PASS*

* In the configuration tested, the EUT complied with the standards specified above

Tested By: Tiny You

(Tiny You)

Reviewed By: Sheek, Luo

(Sheek Luo)

Approved By: Jack Ai

(Jack Ai)



1 Version

Revision History Of Report

Report No.	Version	Description	Issue Date
CQASZ20201001255E-01	Rev.01	Initial report	2020-11-17

2 Test Summary

Test Item	Test Requirement	Test method	Result
Antenna Requirement	47 CFR Part 15, Subpart C Section 15.203/15.247 (c)	ANSI C63.10 2013	PASS
AC Power Line Conducted Emission	47 CFR Part 15, Subpart C Section 15.207	ANSI C63.10 2013	N/A
Conducted Peak Output Power	47 CFR Part 15, Subpart C Section 15.247 (b)(3)	ANSI C63.10 2013	PASS
6dB Occupied Bandwidth	47 CFR Part 15, Subpart C Section 15.247 (a)(2)	ANSI C63.10 2013	PASS
Power Spectral Density	47 CFR Part 15, Subpart C Section 15.247 (e)	ANSI C63.10 2013	PASS
Band-edge for RF Conducted Emissions	47 CFR Part 15, Subpart C Section 15.247(d)	ANSI C63.10 2013	PASS
RF Conducted Spurious Emissions	47 CFR Part 15, Subpart C Section 15.247(d)	ANSI C63.10 2013	PASS
Radiated Spurious Emissions	47 CFR Part 15, Subpart C Section 15.205/15.209	ANSI C63.10 2013	PASS
Restricted bands around fundamental frequency (Radiated Emission)	47 CFR Part 15, Subpart C Section 15.205/15.209	ANSI C63.10 2013	PASS

N/A: When the EUT is powered by DC , So Not Applicable

3 Contents

	Page
1 VERSION	2
2 TEST SUMMARY	3
3 CONTENTS	4
4 GENERAL INFORMATION	5
4.1 CLIENT INFORMATION	5
4.2 GENERAL DESCRIPTION OF EUT	5
4.3 TEST ENVIRONMENT	7
4.4 DESCRIPTION OF SUPPORT UNITS	7
4.5 STATEMENT OF THE MEASUREMENT UNCERTAINTY	8
4.6 TEST LOCATION	9
4.7 TEST FACILITY	9
4.8 DEVIATION FROM STANDARDS	9
4.9 OTHER INFORMATION REQUESTED BY THE CUSTOMER	9
4.10 EQUIPMENT LIST	10
5 TEST RESULTS AND MEASUREMENT DATA	11
5.1 ANTENNA REQUIREMENT	11
5.2 CONDUCTED PEAK OUTPUT POWER	12
5.3 6dB OCCUPY BANDWIDTH	16
5.4 POWER SPECTRAL DENSITY	20
5.5 BAND-EDGE FOR RF CONDUCTED EMISSIONS	24
5.6 SPURIOUS RF CONDUCTED EMISSIONS	27
5.7 RADIATED SPURIOUS EMISSION & RESTRICTED BANDS	37
5.7.1 <i>Spurious Emissions</i>	37
6 PHOTOGRAPHS - EUT TEST SETUP	43
6.1 RADIATED SPURIOUS EMISSION	43
7 PHOTOGRAPHS - EUT CONSTRUCTIONAL DETAILS	45

4 General Information

4.1 Client Information

Applicant:	Shenzhen Hollyland Technology Co., Ltd
Address of Applicant:	8F, Building 5D, Skyworth Innovation Valley, Tangtou Road. Shiyuan Street, Baoan District Shenzhen, China
Manufacturer:	Shenzhen Hollyland Technology Co., Ltd
Address of Manufacturer:	8F, Building 5D, Skyworth Innovation Valley, Tangtou Road. Shiyuan Street, Baoan District Shenzhen, China
Factory:	Shenzhen Hollyland Technology Co., Ltd
Address of Factory:	8F, Building 5D, Skyworth Innovation Valley, Tangtou Road. Shiyuan Street, Baoan District Shenzhen, China

4.2 General Description of EUT

Product Name:	WIRELESS MICROPHONE
Model No.:	LARK 150, LARK 150 S, LARK 150 SE, LARK 150 Lite, LARK 150 PRO
Test Model No.:	LARK 150
Trade Mark:	HOLLYLAND
Hardware Version:	F782353068
Software Version:	V1.0.4.3
Operation Frequency:	2402MHz~2480MHz
Modulation Type:	GFSK
Transfer Rate:	1Mbps
Number of Channel:	26
Product Type:	<input type="checkbox"/> Mobile <input checked="" type="checkbox"/> Portable <input type="checkbox"/> Fix Location
Test Software of EUT:	RF Test (manufacturer declare)
Antenna Type:	Ceramic antenna
Antenna Gain:	1.5dBi
EUT Power Supply:	lithium battery:DC3.7V, Charge by DC5.0V

Note:

Model No.: LARK 150, LARK 150 S, LARK 150 SE, LARK 150 Lite, LARK 150 PRO

Only the model LARK 150 was tested, since the electrical circuit design, layout, components used and internal wiring were identical for the above models, with difference being model name.

Operation Frequency each of channel							
Channel	Frequency	Channel	Frequency	Channel	Frequency	Channel	Frequency
0	2402MHz	8	2426MHz	16	2450MHz	24	2474MHz
1	2405MHz	9	2429MHz	17	2453MHz	25	2477MHz
2	2408MHz	10	2432MHz	18	2456MHz	26	2480MHz
3	2411MHz	11	2435MHz	19	2459MHz		
4	2414MHz	12	2438MHz	20	2462MHz		
5	2417MHz	13	2441MHz	21	2465MHz		
6	2420MHz	14	2444MHz	22	2468MHz		
7	2423MHz	15	2447MHz	23	2471MHz		

Note:

In section 15.31(m), regards to the operating frequency range over 10 MHz, the lowest frequency, the middle frequency, and the highest frequency of channel were selected to perform the test, and the selected channel see below:

Channel	Frequency
The lowest channel (CH0)	2402MHz
The middle channel (CH13)	2440MHz
The highest channel (CH26)	2480MHz

4.3 Test Environment

Operating Environment:	
Radiated Emissions:	
Temperature:	25.1 °C
Humidity:	52 % RH
Atmospheric Pressure:	1009mbar
Radio conducted item test (RF Conducted test room):	
Temperature:	25.3 °C
Humidity:	54 % RH
Atmospheric Pressure:	1009mbar
Test mode:	
Transmitting mode:	Use test software to set the lowest frequency, the middle frequency and the highest frequency keep transmitting of the EUT. Note: In the process of transmitting of EUT, the duty cycle >98%.

4.4 Description of Support Units

The EUT has been tested with associated equipment below.

1) Support equipment

Description	Manufacturer	Model No.	Certification	Supplied by
PC	Lenovo	ThinkPad E450c	FCC ID	CQA

4.5 Statement of the measurement uncertainty

The data and results referenced in this document are true and accurate.

The reader is cautioned that there may be errors within the calibration limits of the equipment and facilities.

The measurement uncertainty was calculated for all measurements listed in this test report acc. to CISPR 16 - 4 „Specification for radio disturbance and immunity measuring apparatus and methods – Part 4: Uncertainty in EMC Measurements“ and is documented in the **Shenzhen Huaxia Testing Technology Co., Ltd.** quality system acc. to DIN EN ISO/IEC 17025.

Furthermore, component and process variability of devices similar to that tested may result in additional deviation. The manufacturer has the sole responsibility of continued compliance of the device.

Hereafter the best measurement capability for CQA laboratory is reported:

No.	Item	Uncertainty	Notes
1	Radiated Emission (Below 1GHz)	5.12dB	(1)
2	Radiated Emission (Above 1GHz)	4.60dB	(1)
3	Conducted Disturbance (0.15~30MHz)	3.34dB	(1)
4	Radio Frequency	3×10^{-8}	(1)
5	Duty cycle	0.6 %.	(1)
6	Occupied Bandwidth	1.1%	(1)
7	RF conducted power	0.86dB	(1)
8	RF power density	0.74	(1)
9	Conducted Spurious emissions	0.86dB	(1)
10	Temperature test	0.8°C	(1)
11	Humidity test	2.0%	(1)
12	Supply voltages	0.5 %.	(1)
13	Frequency Error	5.5 Hz	(1)

(1) This uncertainty represents an expanded uncertainty expressed at approximately the 95% confidence level using a coverage factor of k=2.

4.6 Test Location

Shenzhen Huaxia Testing Technology Co., Ltd,

1F., Block A of Tongsheng Technology Building, Huahui Road, Dalang Street, Longhua District, Shenzhen, China

4.7 Test Facility

The test facility is recognized, certified, or accredited by the following organizations:

- **A2LA (Certificate No. 4742.01)**

Shenzhen Huaxia Testing Technology Co., Ltd., Shenzhen EMC Laboratory is accredited by the American Association for Laboratory Accreditation(A2LA). Certificate No. 4742.01.

- **FCC Registration No.: 522263**

Shenzhen Huaxia Testing Technology Co., Ltd., Shenzhen EMC Laboratory has been registered and fully described in a report filed with the (FCC) Federal Communications Commission. The acceptance letter from the FCC is maintained in our files. Registration No.:522263

4.8 Deviation from Standards

None.

4.9 Other Information Requested by the Customer

None.

4.10 Equipment List

Test Equipment	Manufacturer	Model No.	Instrument No.	Calibration Date	Calibration Due Date
EMI Test Receiver	R&S	ESR7	CQA-005	2020/10/25	2021/10/24
Spectrum analyzer	R&S	FSU26	CQA-038	2020/10/25	2021/10/24
Preamplifier	MITEQ	AMF-6D-02001800-29-20P	CQA-036	2020/10/25	2021/10/24
Loop antenna	Schwarzbeck	FMZB1516	CQA-060	2020/10/21	2021/10/20
Bilog Antenna	R&S	HL562	CQA-011	2020/9/26	2021/9/25
Horn Antenna	R&S	HF906	CQA-012	2020/9/26	2021/9/25
Horn Antenna	Schwarzbeck	BBHA 9170	CQA-088	2020/9/25	2021/9/24
Coaxial Cable (Above 1GHz)	CQA	N/A	C007	2020/9/26	2021/9/25
Coaxial Cable (Below 1GHz)	CQA	N/A	C013	2020/9/26	2021/9/25
Antenna Connector	CQA	RFC-01	CQA-080	2020/9/26	2021/9/25
RF cable(9KHz~40GHz)	CQA	RF-01	CQA-079	2020/9/26	2021/9/25
Power divider	MIDWEST	PWD-2533-02-SMA-79	CQA-067	2020/9/26	2021/9/25
DC power	KEYSIGHT	E3631A	CQA-028	2020/9/26	2021/9/25

Note:

The temporary antenna connector is soldered on the PCB board in order to perform conducted tests and this temporary antenna connector is listed in the equipment list.

5 Test results and Measurement Data

5.1 Antenna Requirement

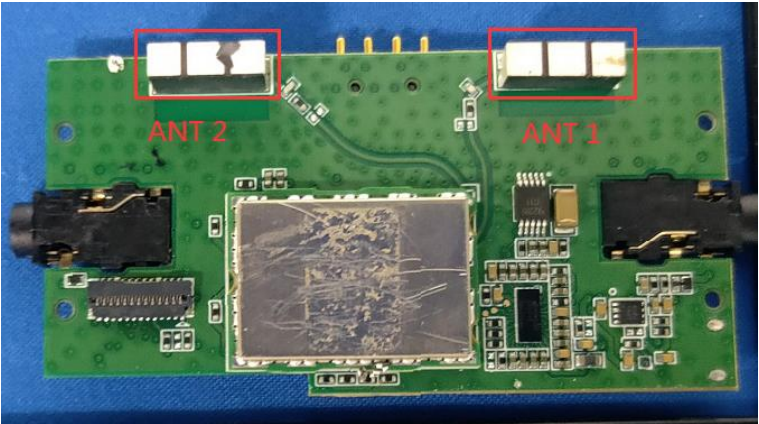
Standard requirement:	47 CFR Part 15C Section 15.203 /247(c)
<p>15.203 requirement: An intentional radiator shall be designed to ensure that no antenna other than that furnished by the responsible party shall be used with the device. The use of a permanently attached antenna or of an antenna that uses a unique coupling to the intentional radiator, the manufacturer may design the unit so that a broken antenna can be replaced by the user, but the use of a standard antenna jack or electrical connector is prohibited.</p> <p>15.247(b) (4) requirement: The conducted output power limit specified in paragraph (b) of this section is based on the use of antennas with directional gains that do not exceed 6 dBi. Except as shown in paragraph (c) of this section, if transmitting antennas of directional gain greater than 6 dBi are used, the conducted output power from the intentional radiator shall be reduced below the stated values in paragraphs (b)(1), (b)(2), and (b)(3) of this section, as appropriate, by the amount in dB that the directional gain of the antenna exceeds 6 dBi.</p>	
EUT Antenna:	
<p>The antenna is Ceramic antenna. The best case gain of the antenna is 1.5dBi.</p>	

5.2 Conducted Peak Output Power

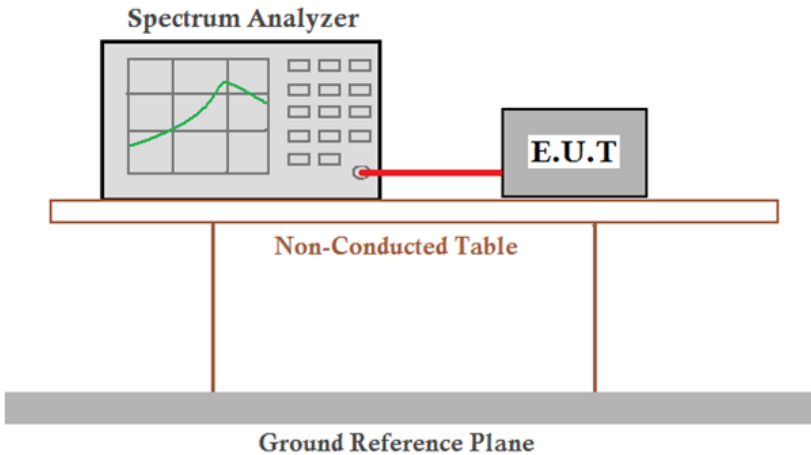
Test Requirement:	47 CFR Part 15C Section 15.247 (b)(1)
Test Method:	ANSI C63.10 2013
Test Setup:	 <p style="text-align: center;"><i>Remark: Offset=Cable loss+ attenuation factor.</i></p>
Limit:	30dBm
Test Mode:	Transmitting with GFSK modulation.
Test Results:	Pass

Measurement Data

ANT1:

GFSK mode			
Test channel	Peak Output Power (dBm)	Limit (dBm)	Result
Lowest	6.87	30.00	Pass
Middle	7.45	30.00	Pass
Highest	7.73	30.00	Pass

ANT2:

GFSK mode			
Test channel	Peak Output Power (dBm)	Limit (dBm)	Result
Lowest	7	30.00	Pass
Middle	7.33	30.00	Pass
Highest	6.7	30.00	Pass

Test plot as follows:
 ANT1:

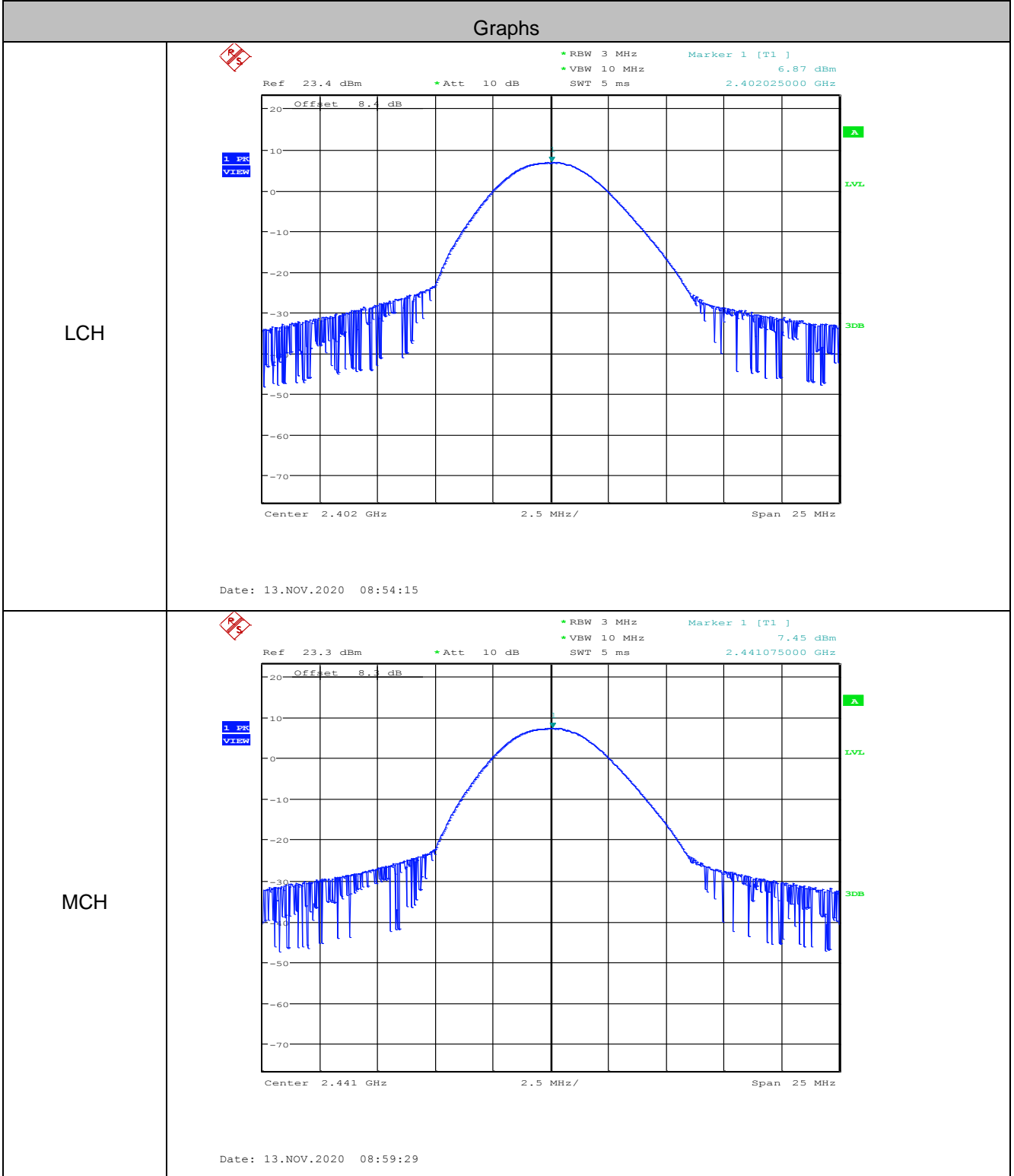

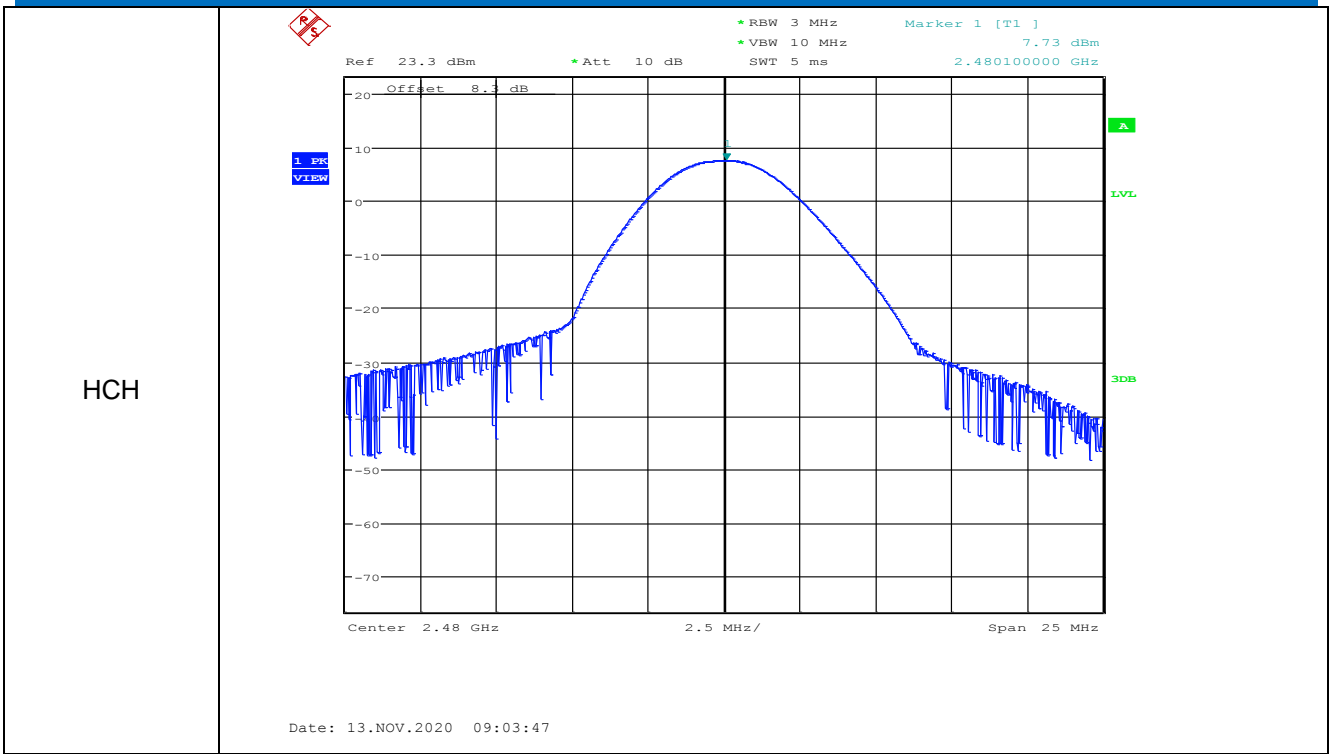

ANT2:

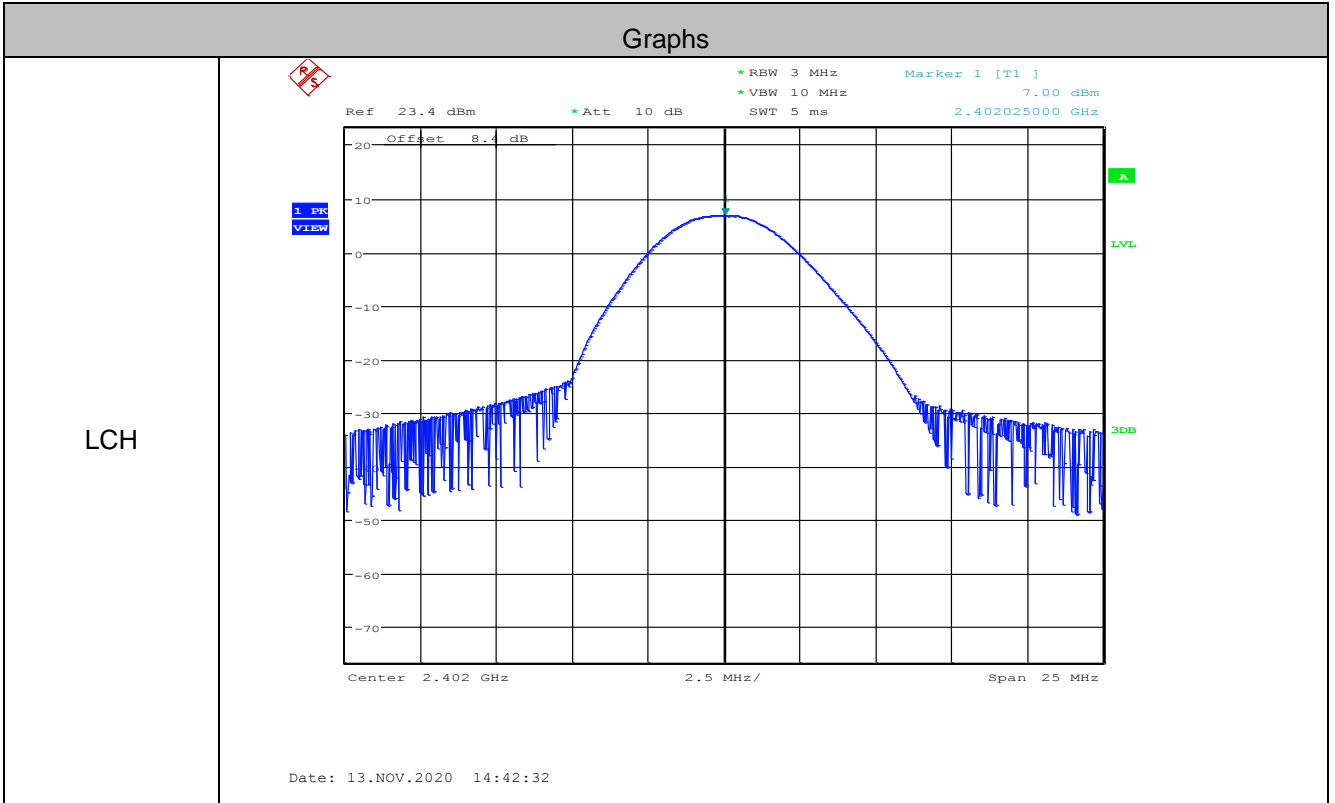

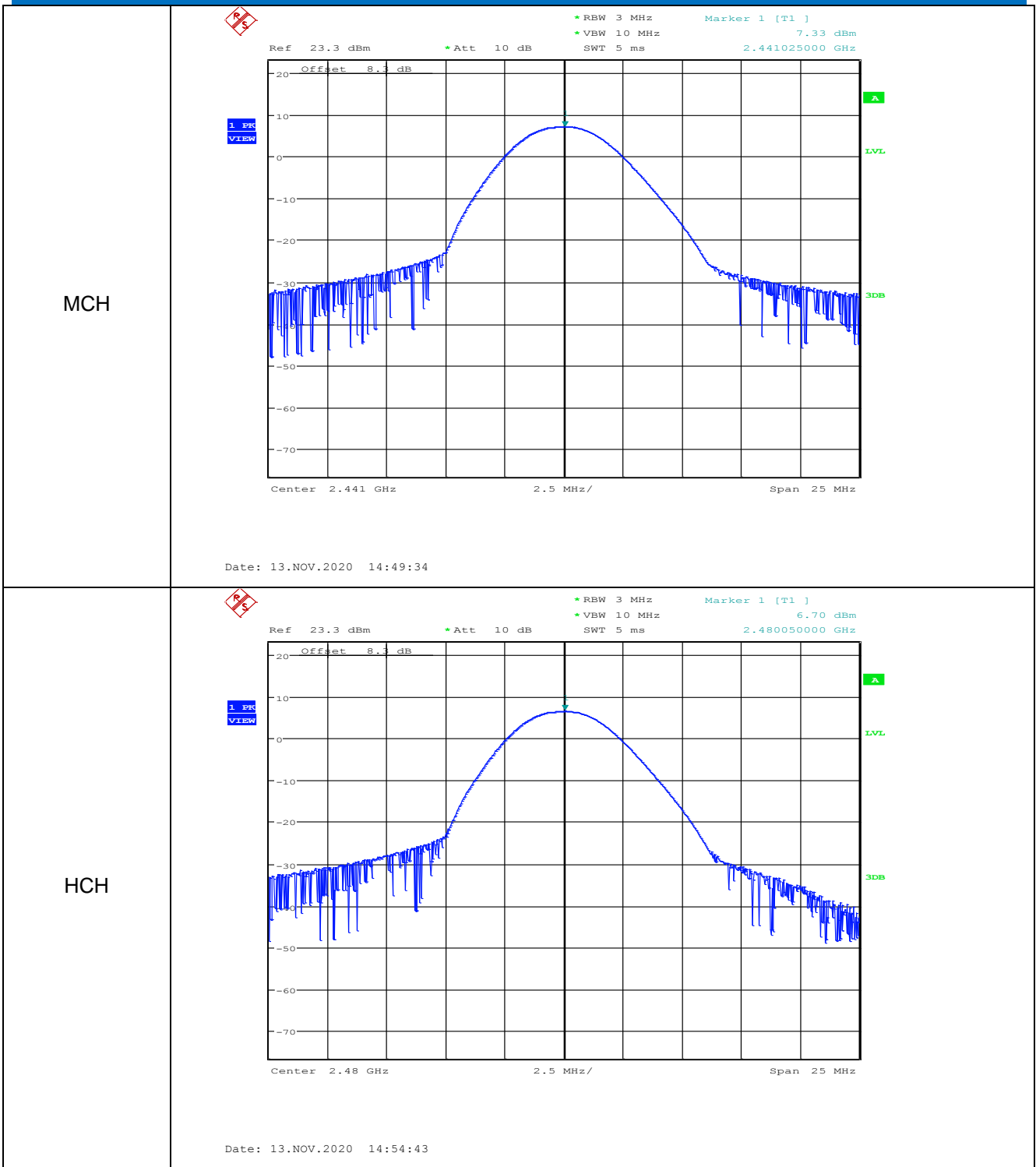

5.3 6dB Occupy Bandwidth

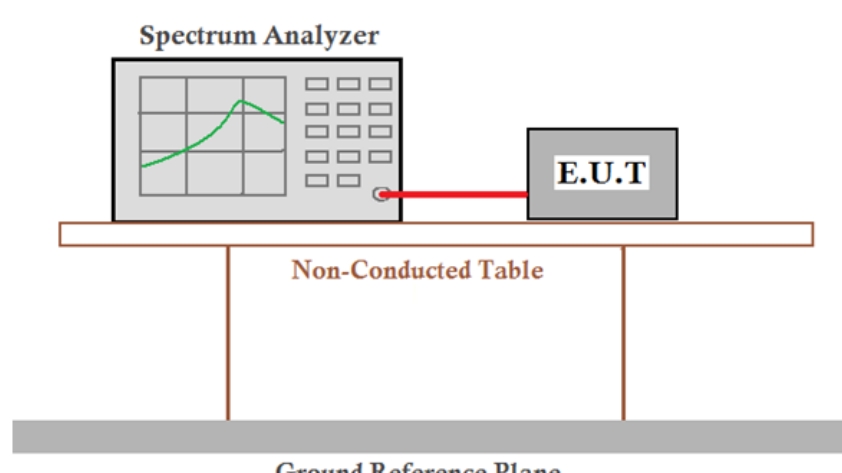
Test Requirement:	47 CFR Part 15C Section 15.247 (a)(2)
Test Method:	ANSI C63.10 2013
Test Setup:	 <p style="text-align: center;">Spectrum Analyzer</p> <p style="text-align: center;">E.U.T</p> <p style="text-align: center;">Non-Conducted Table</p> <p style="text-align: center;">Ground Reference Plane</p> <p><i>Remark: Offset=Cable loss+ attenuation factor.</i></p>
Limit:	≥ 500 kHz
Test Results:	Pass

Measurement Data

ANT1:

GFSK mode			
Test channel	6dB Occupy Bandwidth (MHz)	Limit (MHz)	Result
Lowest	0.708	≥0.5	Pass
Middle	0.712	≥0.5	Pass
Highest	0.708	≥0.5	Pass

ANT2:

GFSK mode			
Test channel	6dB Occupy Bandwidth (MHz)	Limit (MHz)	Result
Lowest	0.664	≥0.5	Pass
Middle	0.672	≥0.5	Pass
Highest	0.616	≥0.5	Pass

Test plot as follows:
ANT1:

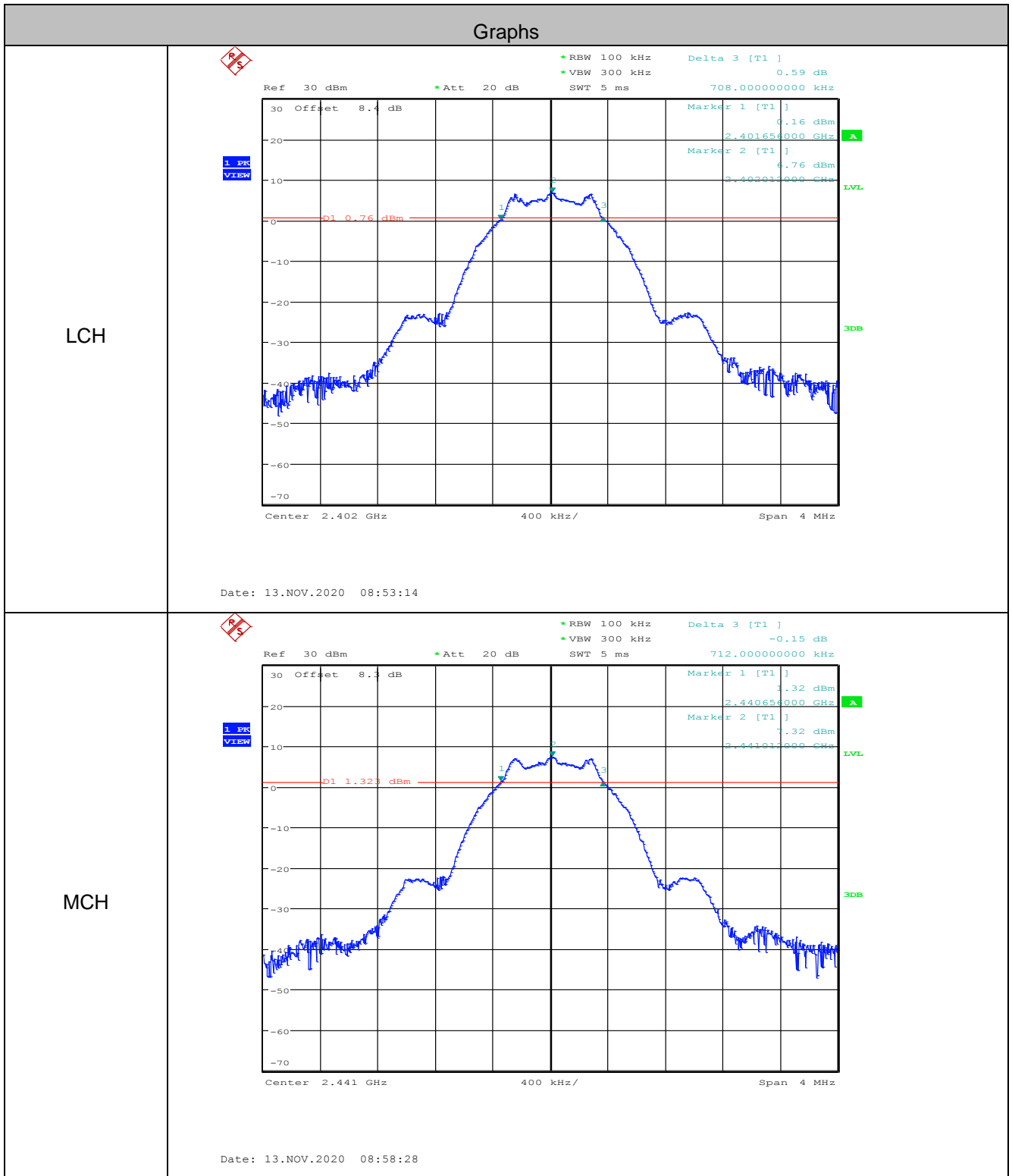

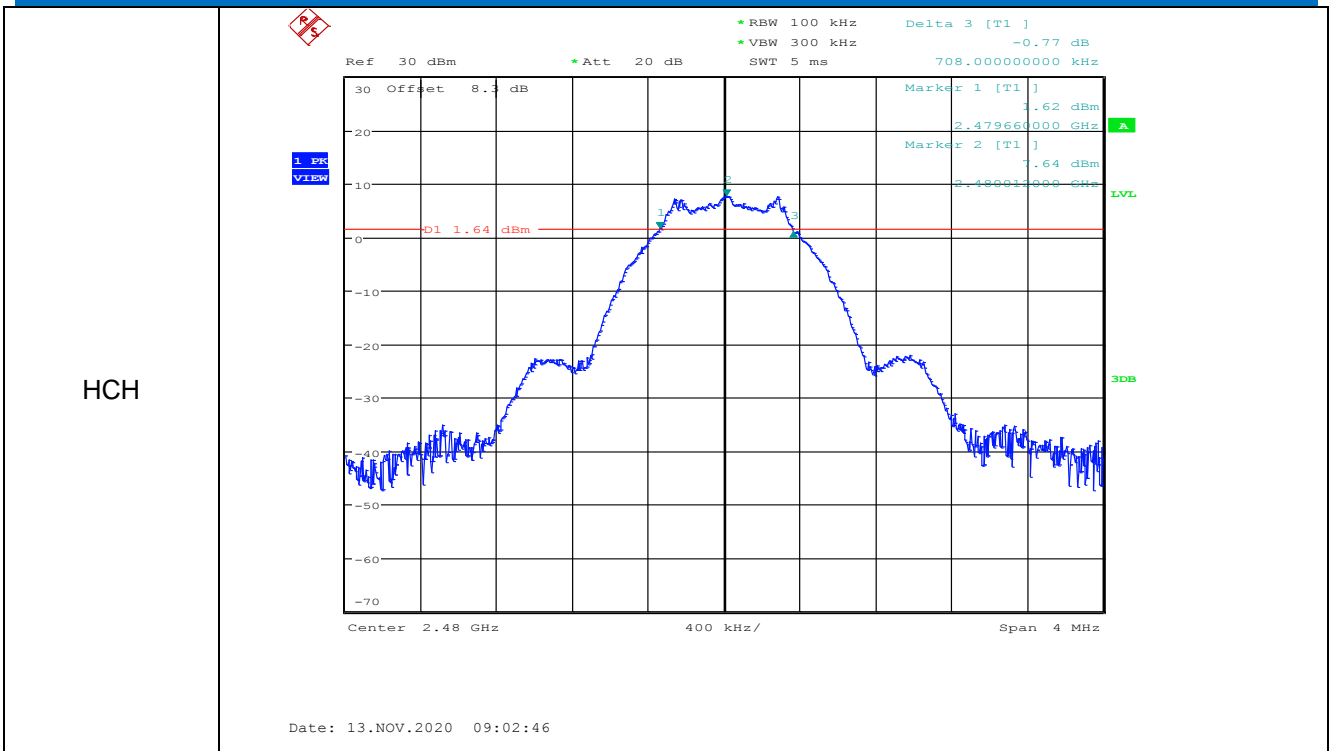

ANT2:

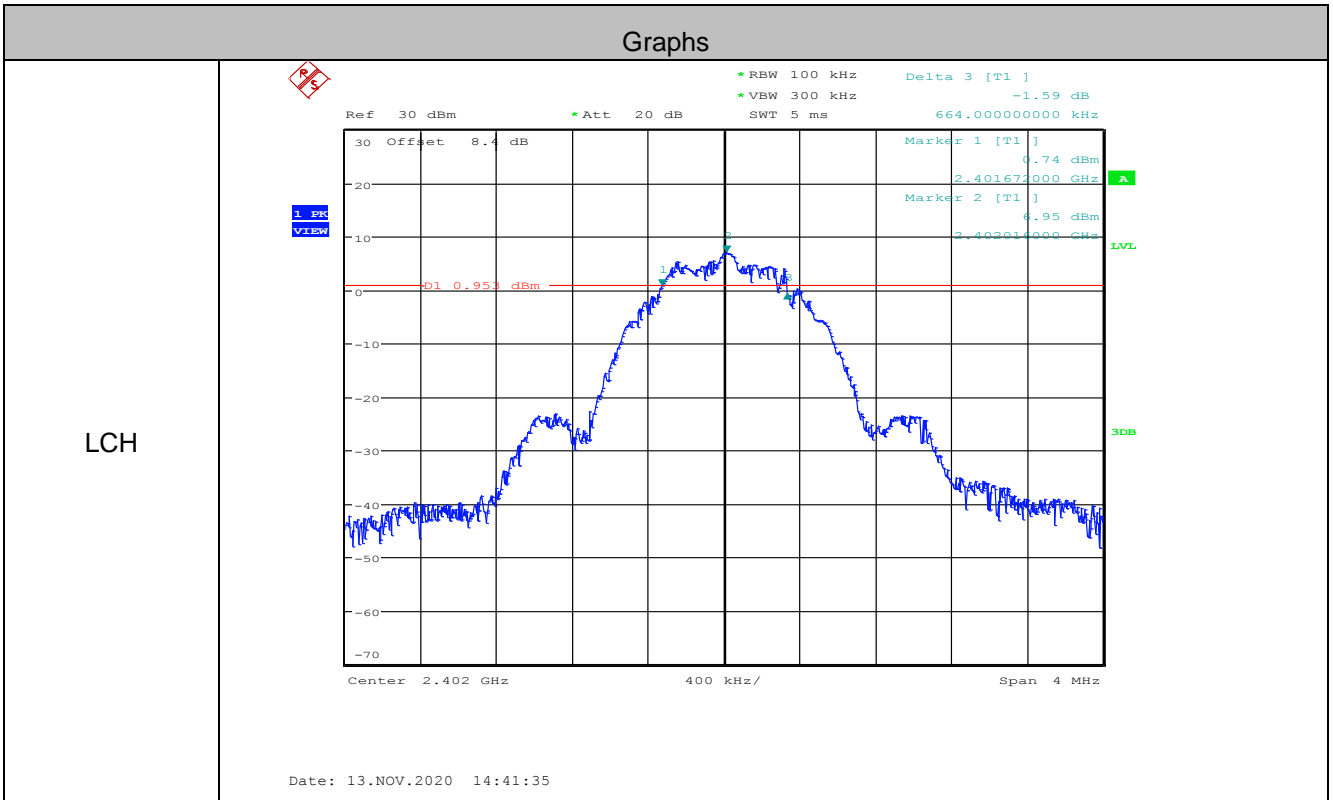

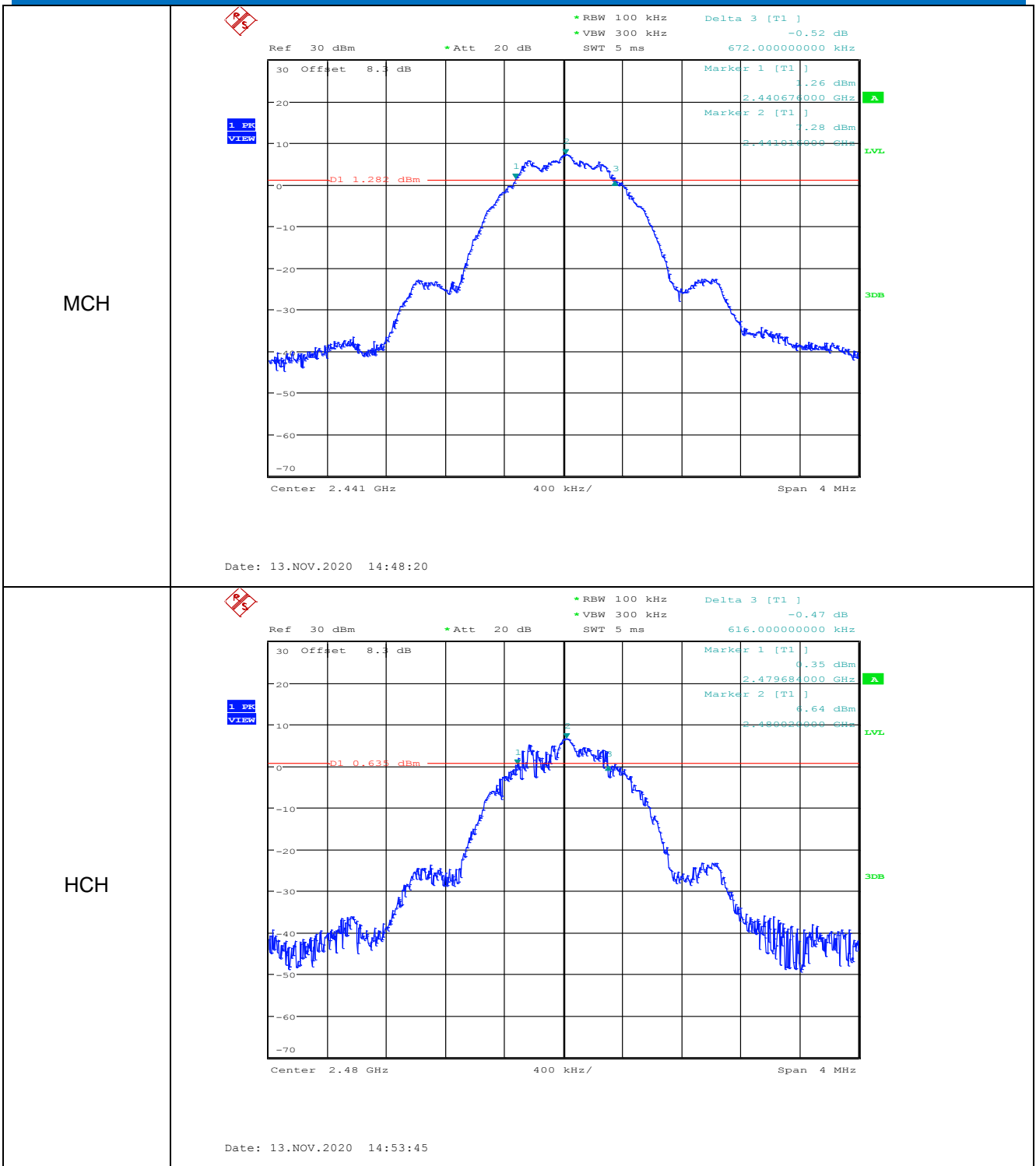

5.4 Power Spectral Density

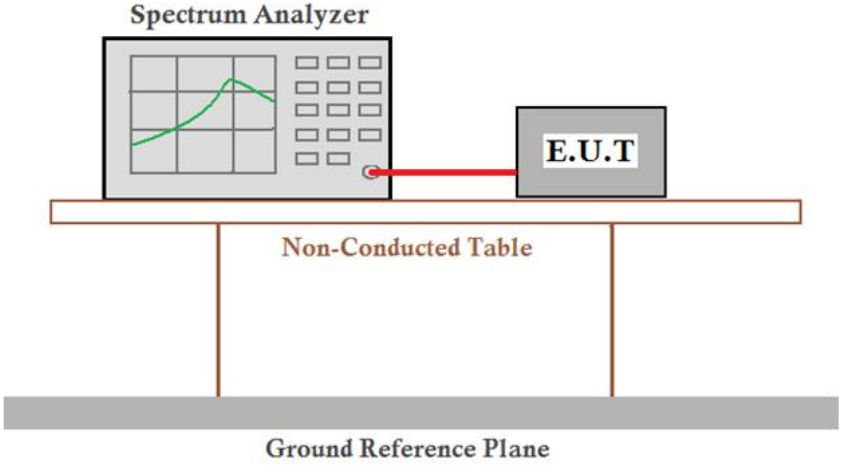
Test Requirement:	47 CFR Part 15C Section 15.247 (e)
Test Method:	ANSI C63.10 2013
Test Setup:	 <p style="text-align: center;">Remark: $Offset = \text{Cable loss} + \text{attenuation factor}$.</p>
Limit:	$\leq 8.00 \text{ dBm/3kHz}$
Test Mode:	Transmitting with GFSK modulation.
Test Results:	Pass

Measurement Data

ANT1:

GFSK mode			
Test channel	Power Spectral Density (dBm/3kHz)	Limit (dBm/3kHz)	Result
Lowest	-5.080	≤ 8.00	Pass
Middle	-3.920	≤ 8.00	Pass
Highest	-4.870	≤ 8.00	Pass

ANT2:

GFSK mode			
Test channel	Power Spectral Density (dBm/3kHz)	Limit (dBm/3kHz)	Result
Lowest	-6.000	≤ 8.00	Pass
Middle	-6.580	≤ 8.00	Pass
Highest	-7.070	≤ 8.00	Pass

Test plot as follows:

ANT1:

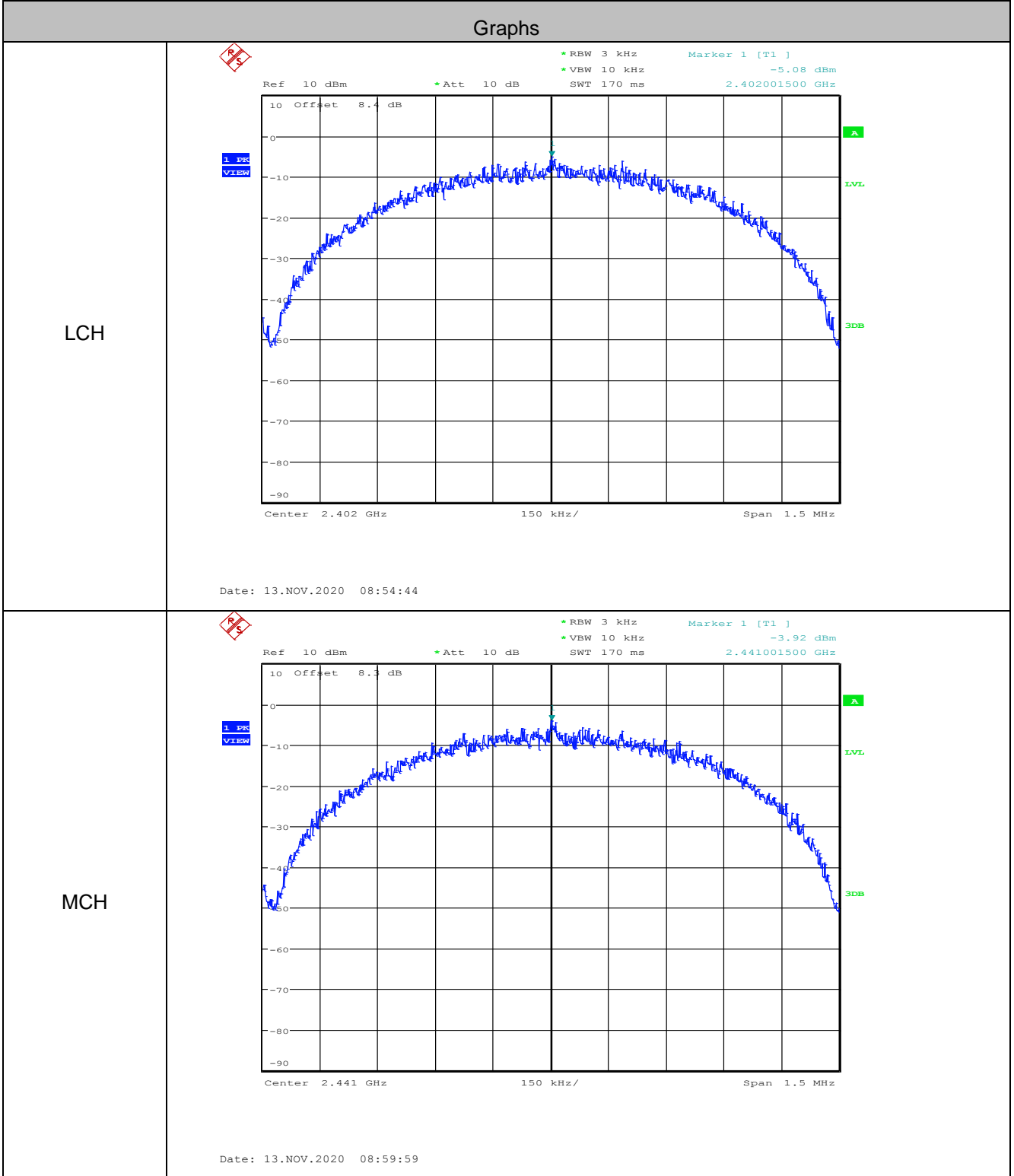

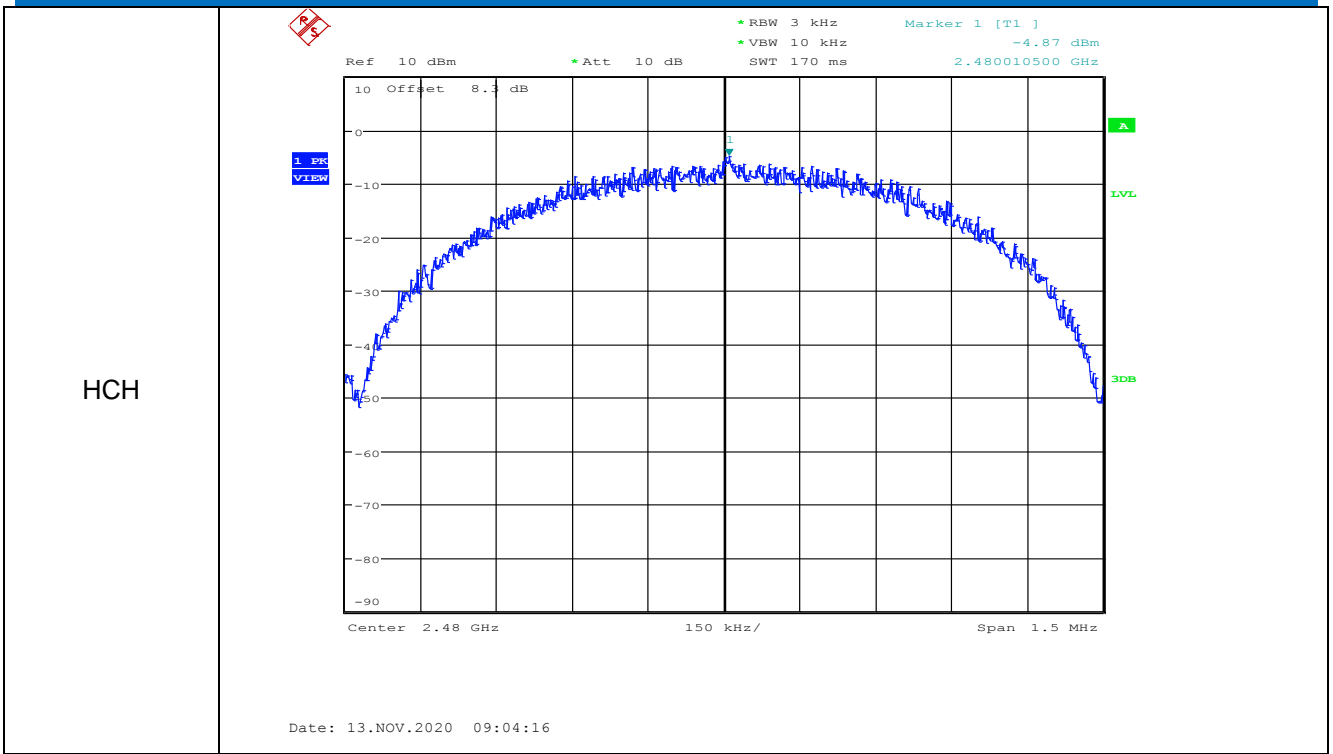

ANT2:

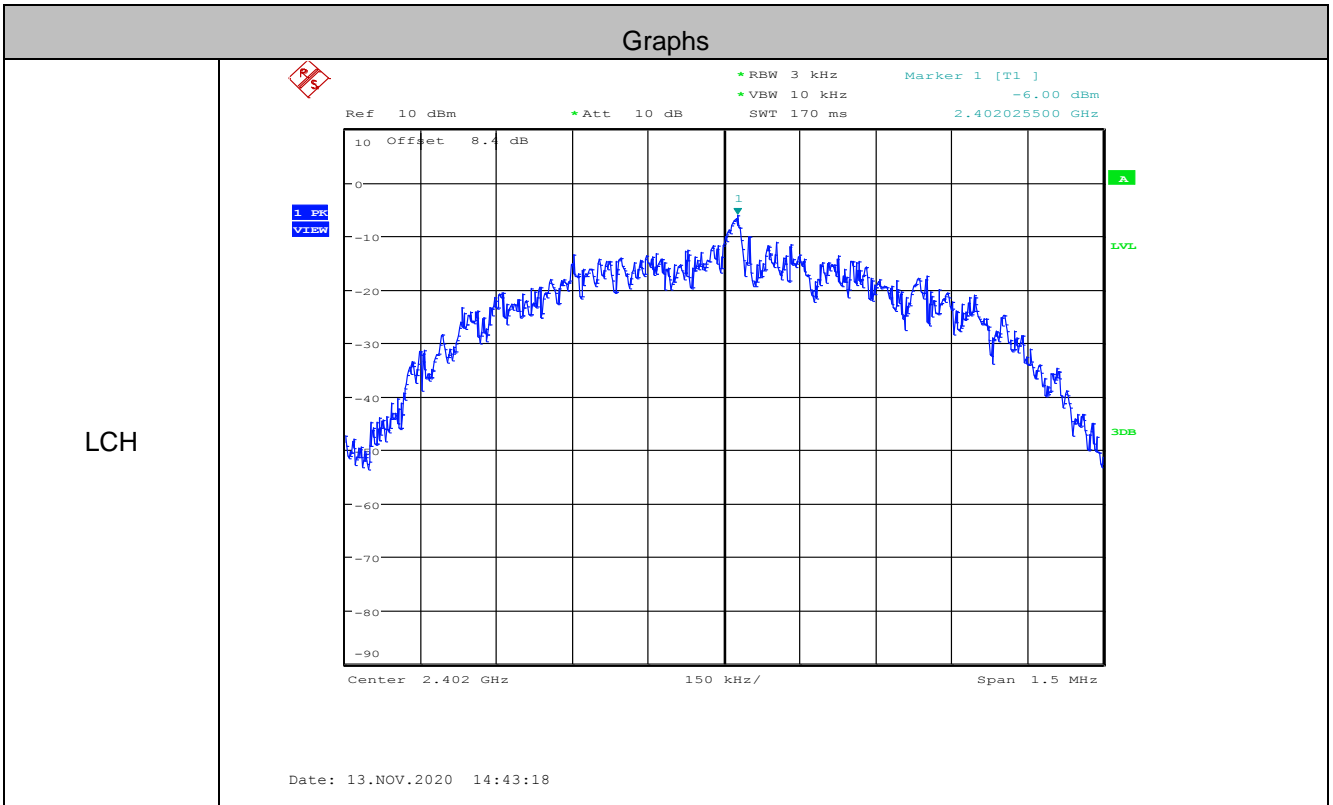

<p>MCH</p>	<p>Ref 10 dBm *Att 10 dB *RBW 3 kHz Marker 1 [T1] -6.58 dBm *VBW 10 kHz SWT 170 ms 2.441022500 GHz</p> <p>10 Offset 8.3 dB</p> <p>1. SPK VIEW</p> <p>Center 2.441 GHz 150 kHz/ Span 1.5 MHz</p> <p>Date: 13.NOV.2020 14:50:02</p>
<p>HCH</p>	<p>Ref 10 dBm *Att 10 dB *RBW 3 kHz Marker 1 [T1] -7.07 dBm *VBW 10 kHz SWT 170 ms 2.480024000 GHz</p> <p>10 Offset 8.3 dB</p> <p>1. SPK VIEW</p> <p>Center 2.48 GHz 150 kHz/ Span 1.5 MHz</p> <p>Date: 13.NOV.2020 14:55:11</p>

5.5 Band-edge for RF Conducted Emissions

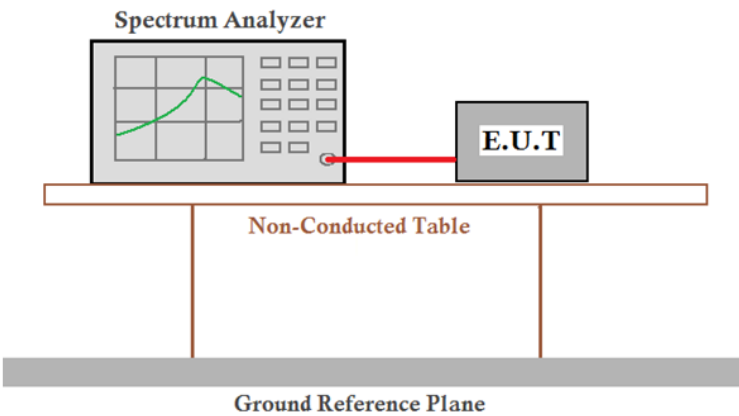
Test Requirement:	47 CFR Part 15C Section 15.247 (d)
Test Method:	ANSI C63.10 2013
Test Setup:	 <p>Remark: $Offset = \text{Cable loss} + \text{attenuation factor}$.</p>
Limit:	In any 100 kHz bandwidth outside the frequency band in which the spread spectrum intentional radiator is operating, the radio frequency power that is produced by the intentional radiator shall be at least 20 dB below that in the 100 kHz bandwidth within the band that contains the highest level of the desired power, based on either an RF conducted or a radiated measurement.
Test Mode:	Transmitting with GFSK modulation.
Test Results:	Pass

ANT1:

GFSK mode				
Test channel	Frequency(MHz)	Emission Level(dBm)	Limit(dBm)	Result
Lowest	2400	-45.430	-13.2	Pass
Highest	2483.5	-47.500	-12.38	Pass

ANT2:

GFSK mode				
Test channel	Frequency(MHz)	Emission Level(dBm)	Limit(dBm)	Result
Lowest	2400	-46.460	-12.91	Pass
Highest	2483.5	-48.230	-13.37	Pass

Test plot as follows:

ANT1:

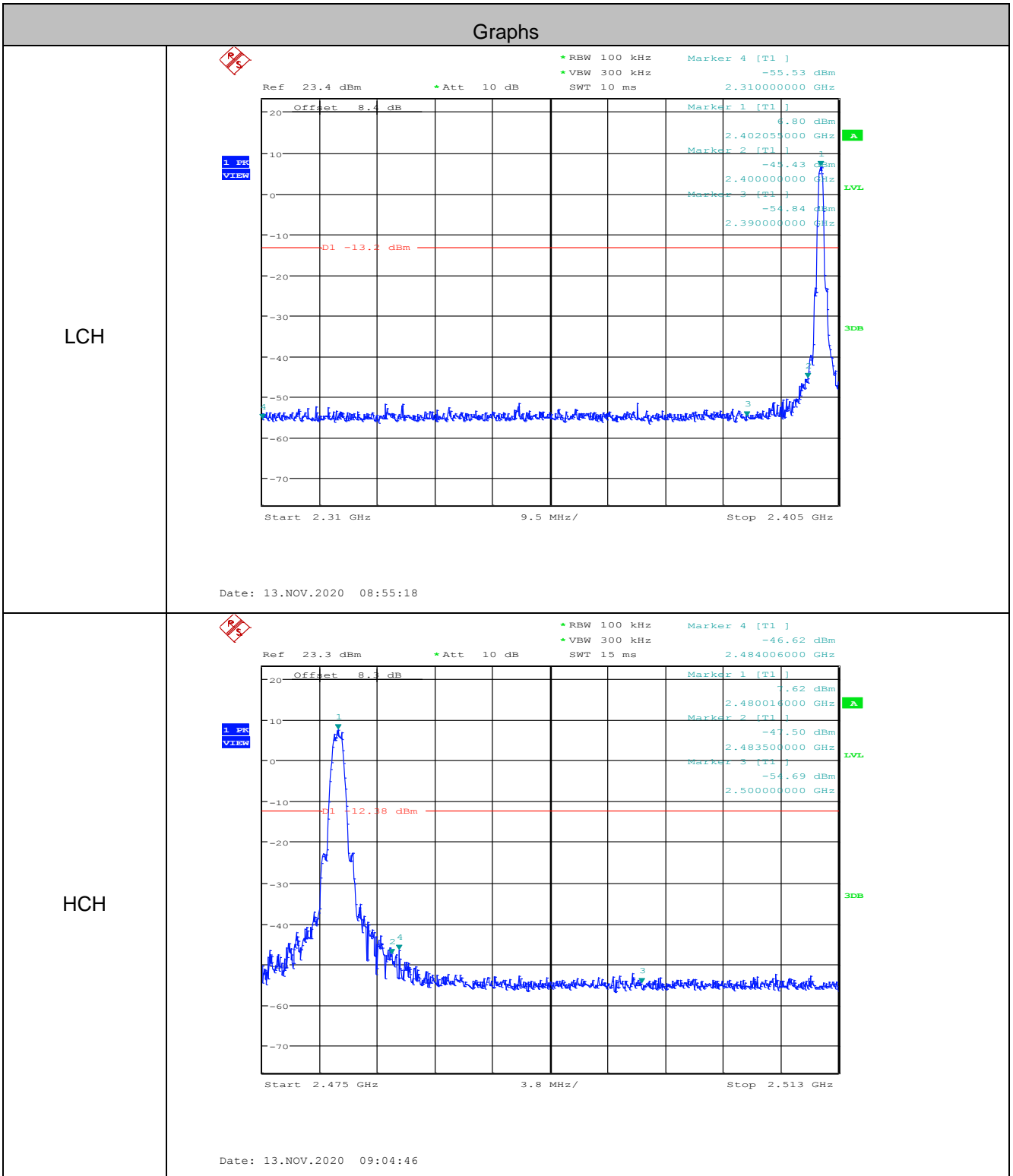

ANT2:

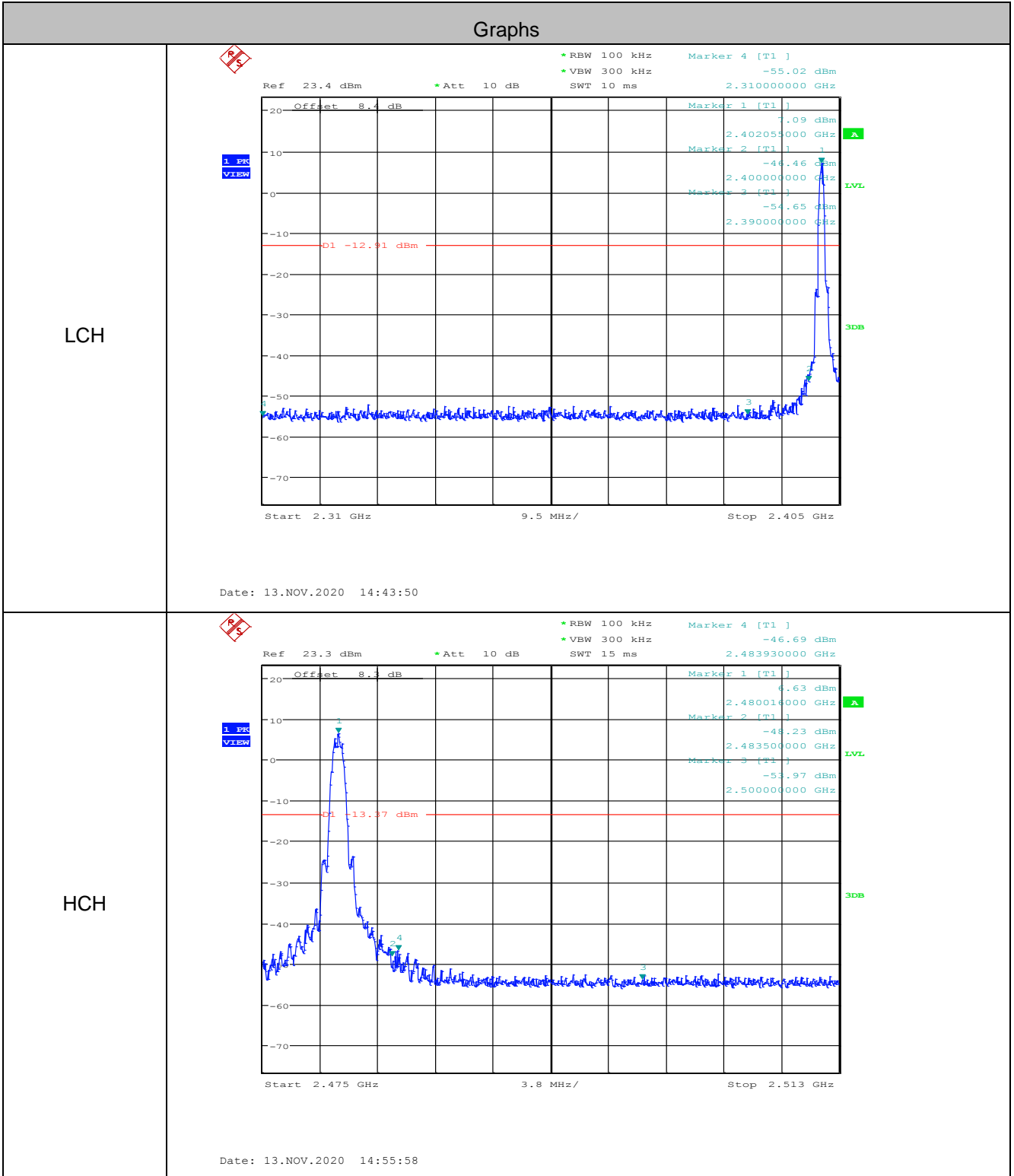

5.6 Spurious RF Conducted Emissions

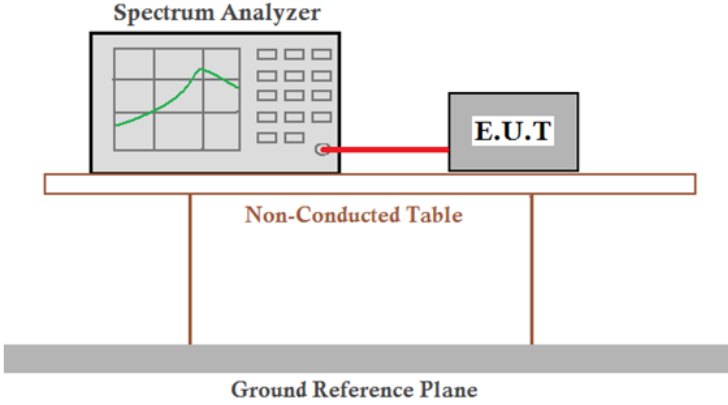
Test Requirement:	47 CFR Part 15C Section 15.247 (d)
Test Method:	ANSI C63.10 2013
Test Setup:	 <p style="text-align: center;"><i>Remark: Offset=Cable loss+ attenuation factor.</i></p>
Limit:	In any 100 kHz bandwidth outside the frequency band in which the spread spectrum intentional radiator is operating, the radio frequency power that is produced by the intentional radiator shall be at least 20 dB below that in the 100 kHz bandwidth within the band that contains the highest level of the desired power, based on either an RF conducted or a radiated measurement.
Test Mode:	Transmitting with GFSK modulation.
Test Results:	Pass

Test plot as follows:

ANT1:

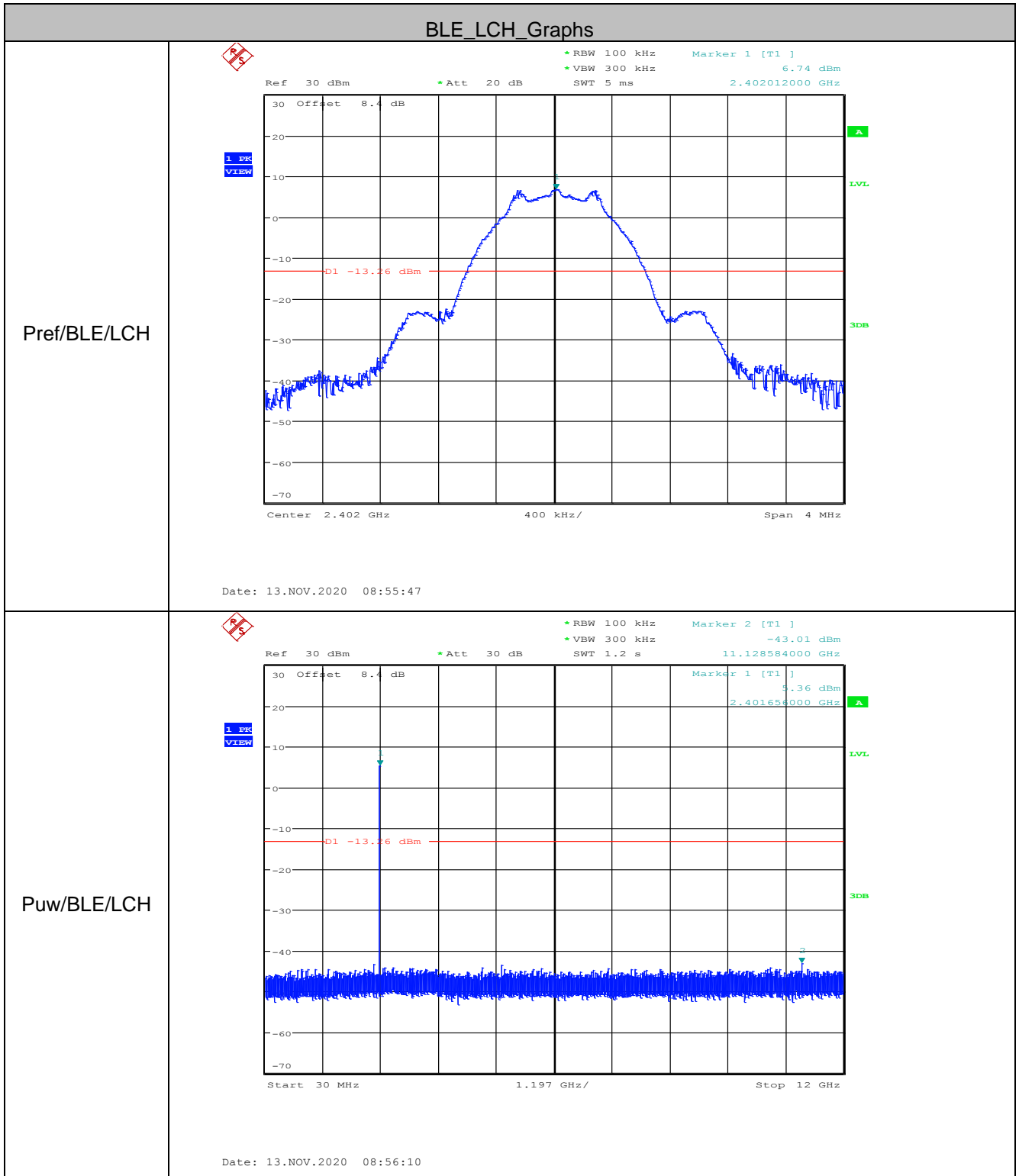

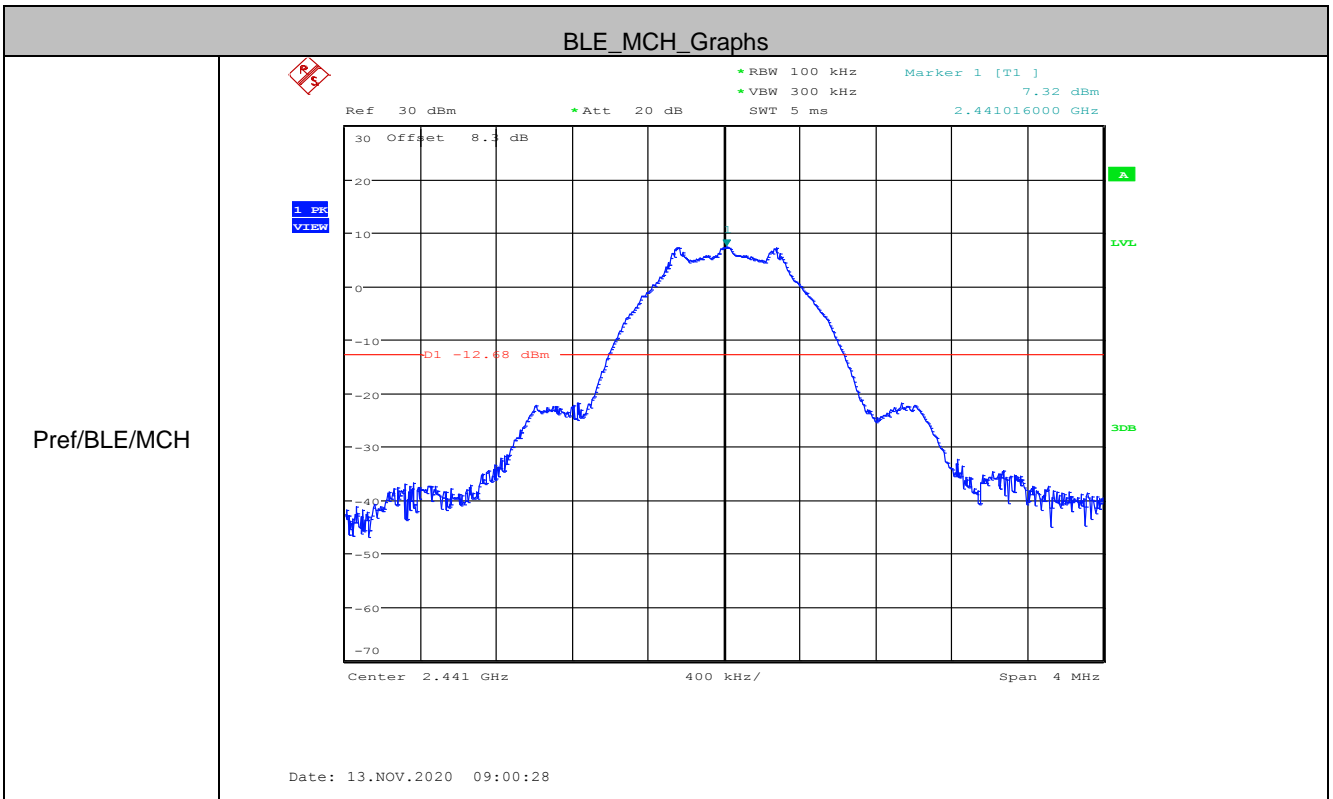
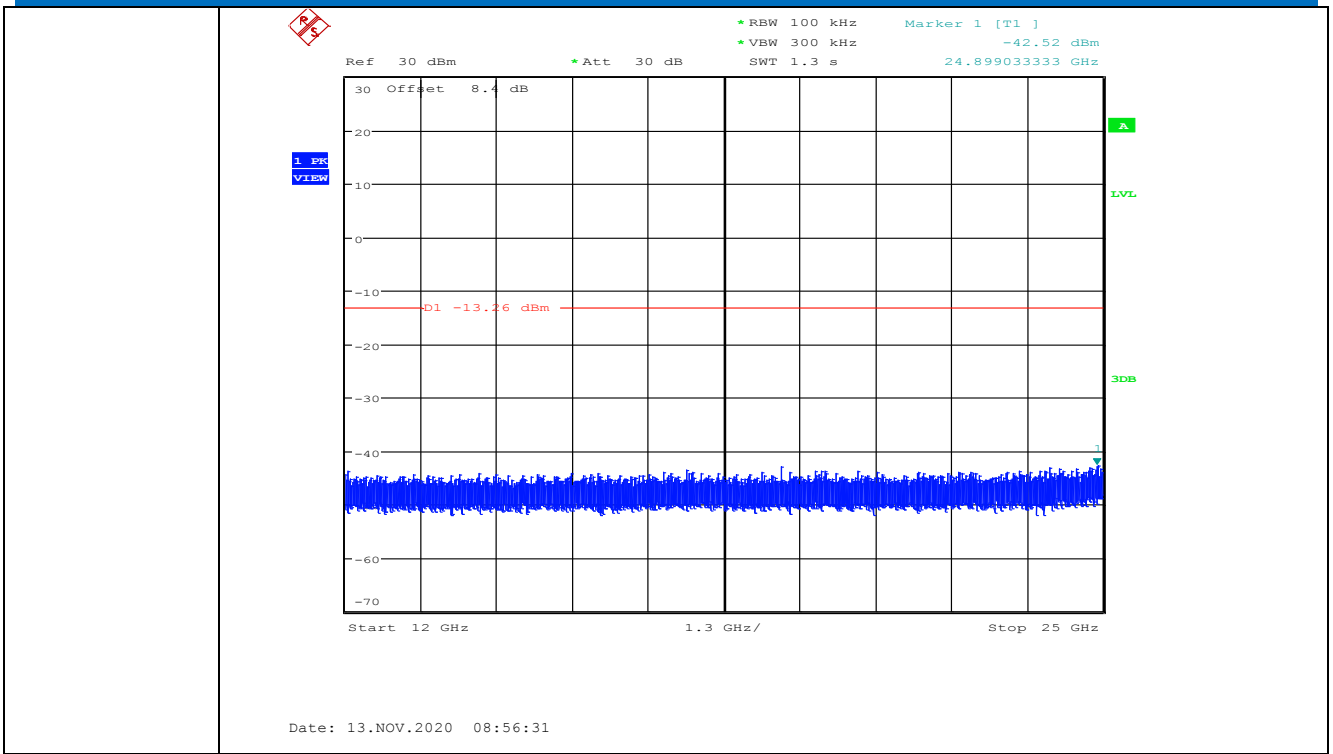

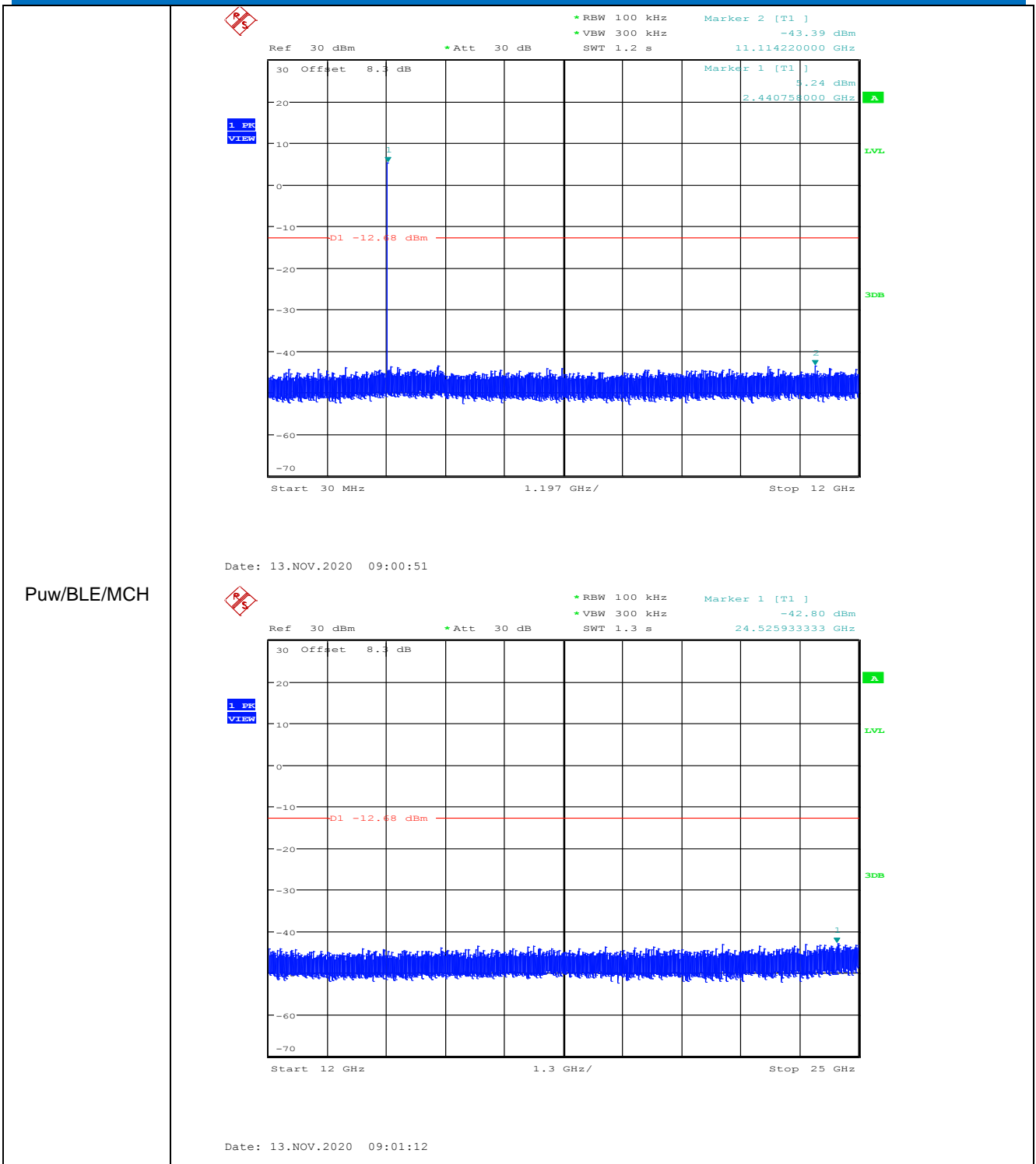

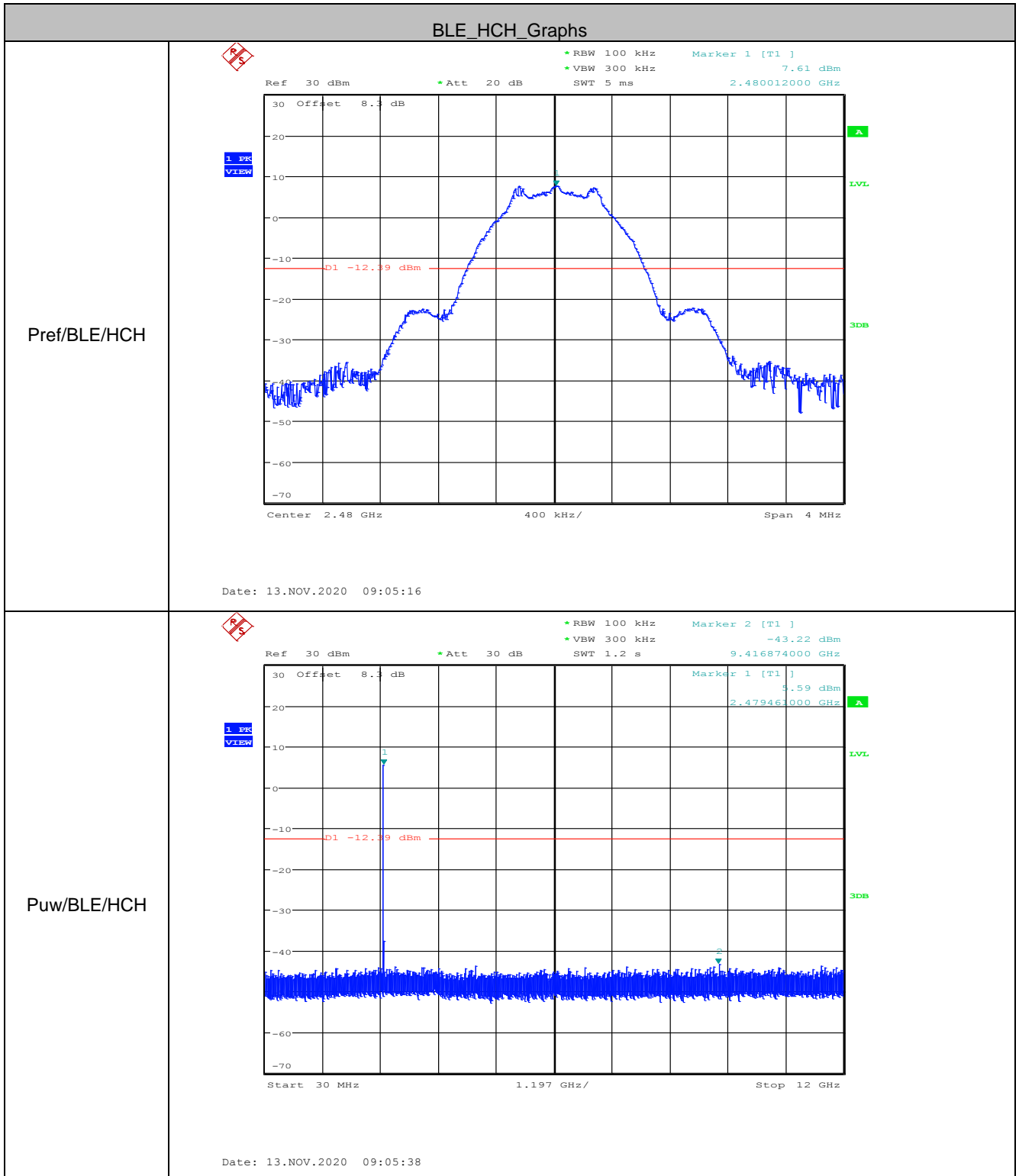

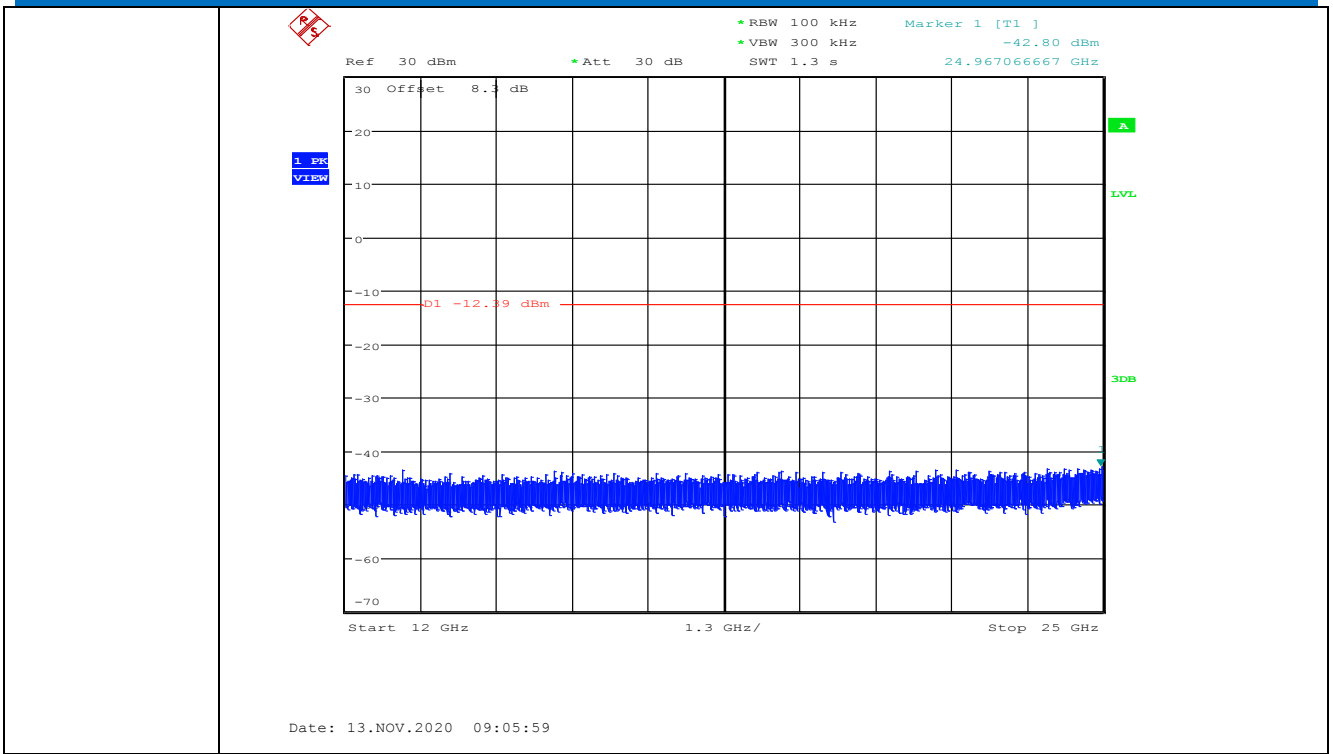

ANT2:

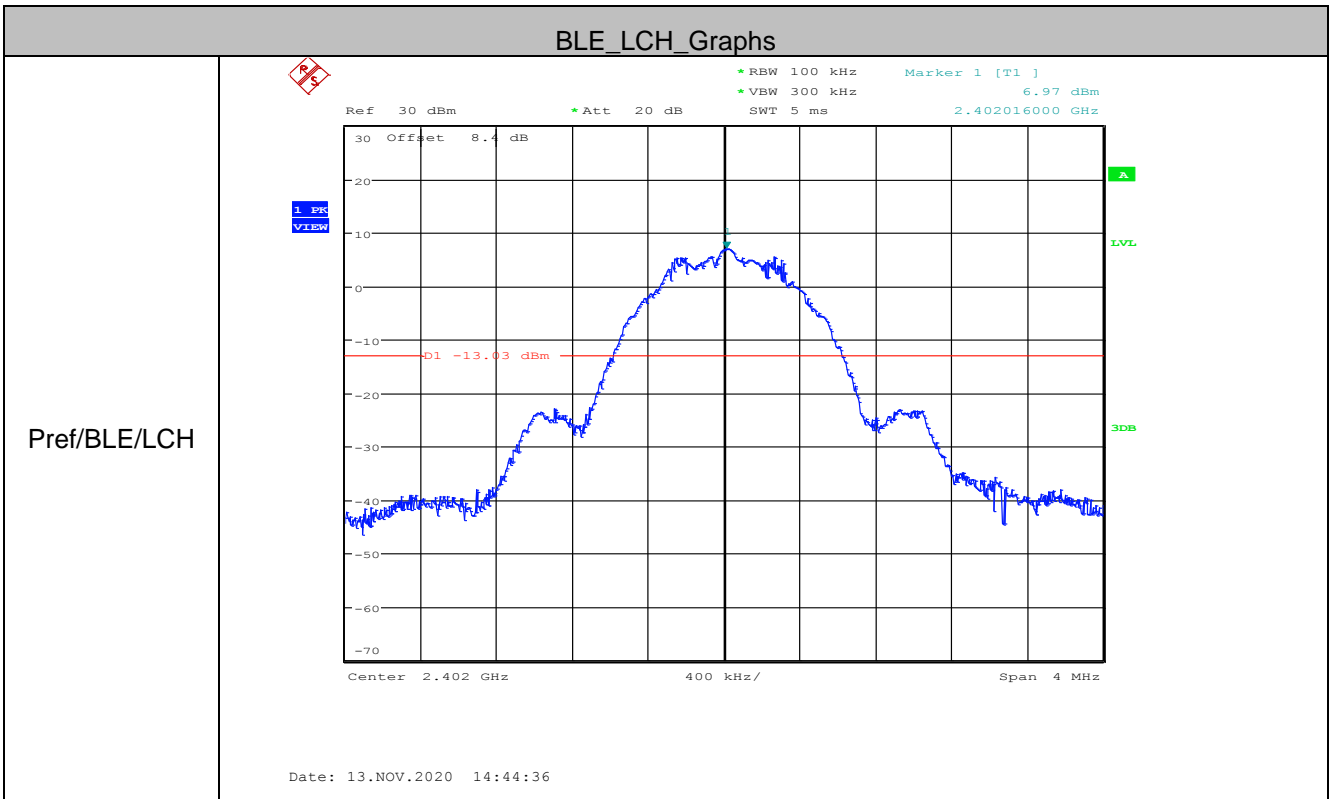

P_{uw}/BLE/LCH

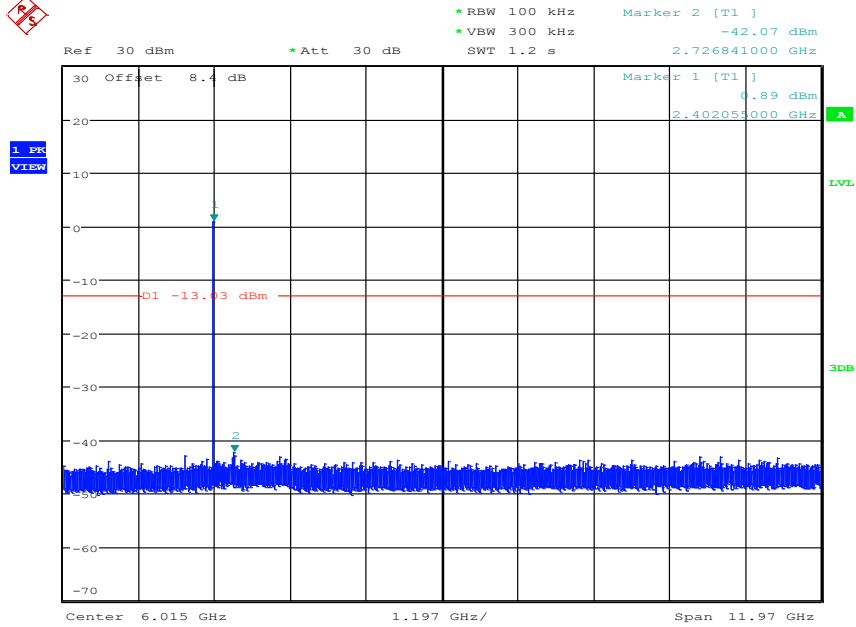

Date: 13.NOV.2020 14:46:31

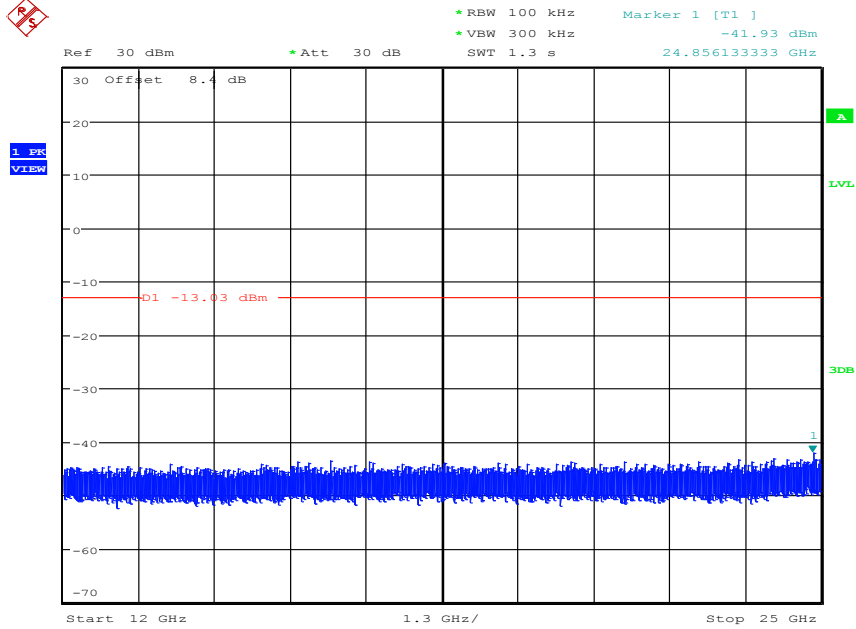

Date: 13.NOV.2020 14:46:52

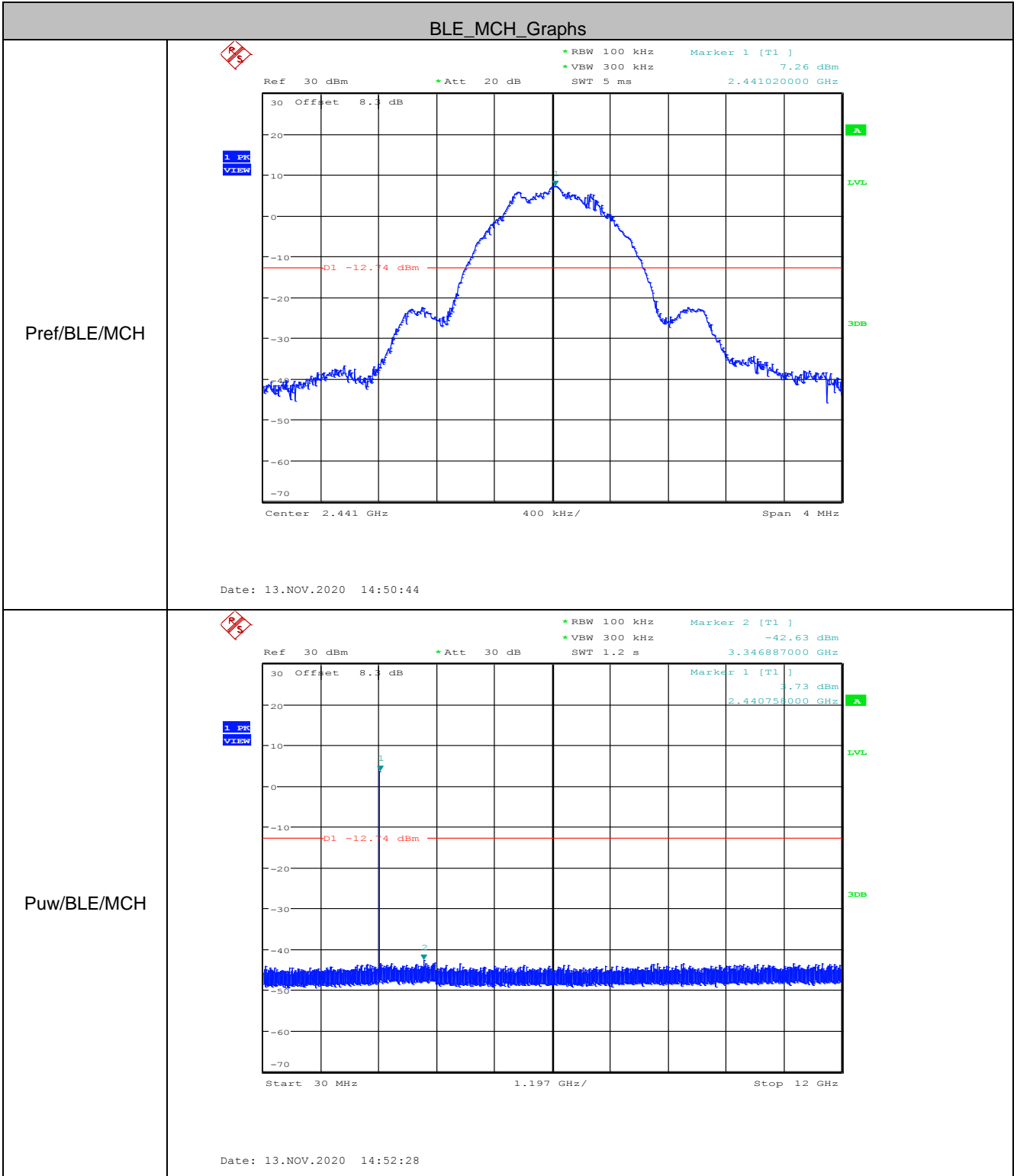

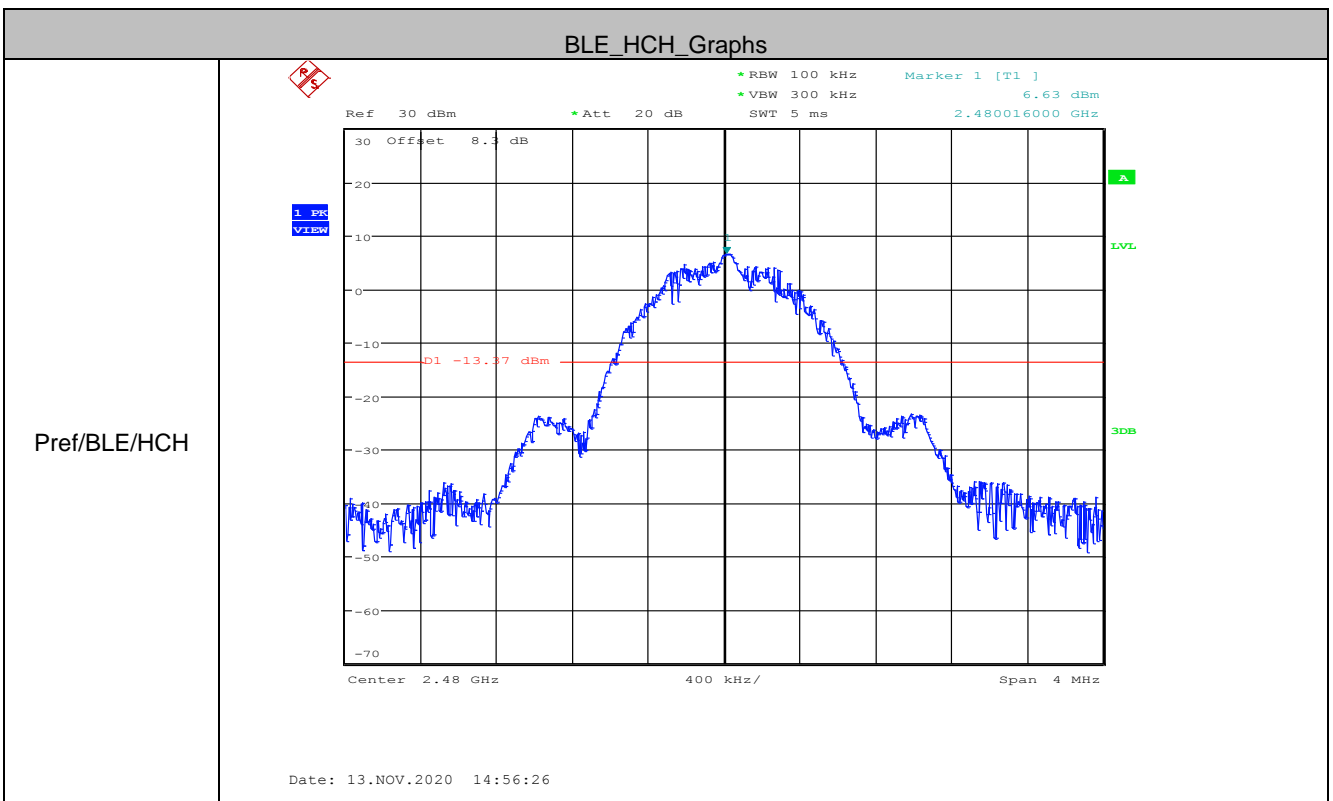
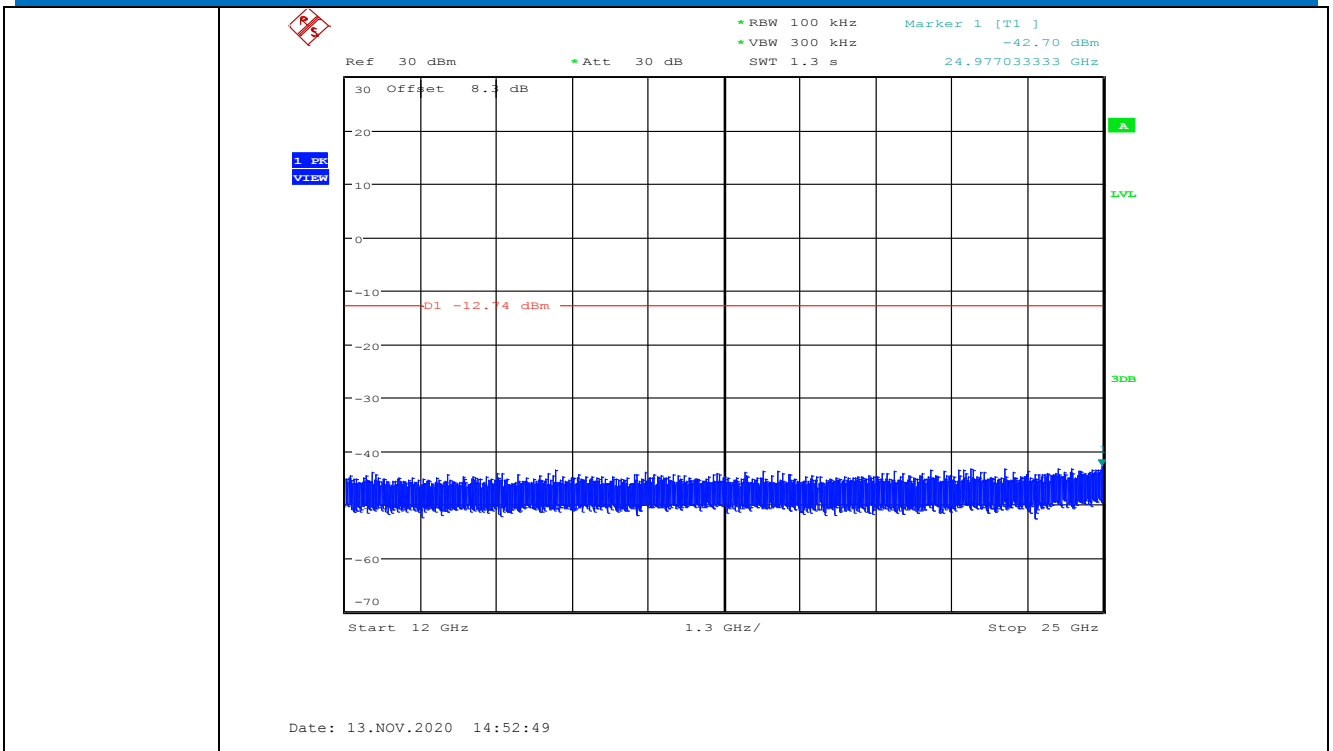

Pref/BLE/HCH

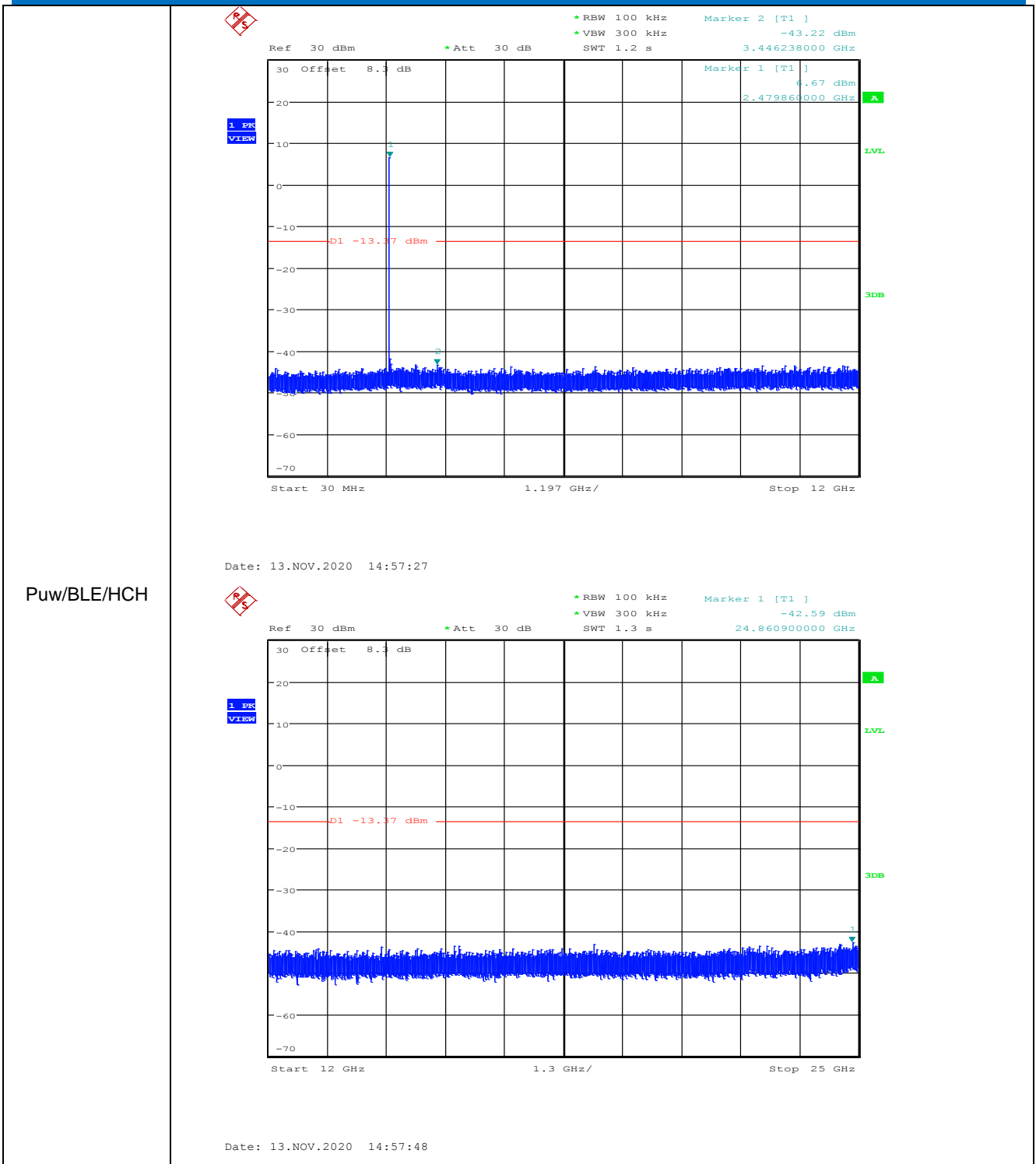

Remark:

Pretest 9kHz to 25GHz, find the highest point when testing, so only the worst data were shown in the test report. Per FCC Part 15.33 (a) and 15.31 (o) ,The amplitude of spurious emissions from intentional radiators which are attenuated more than 20 dB below the permissible value need not be reported unless specifically required elsewhere in this part.

5.7 Radiated Spurious Emission & Restricted bands

5.7.1 Spurious Emissions

Test Requirement:	47 CFR Part 15C Section 15.209 and 15.205				
Test Method:	ANSI C63.10 2013				
Test Site:	Measurement Distance: 3m (Semi-Anechoic Chamber)				
Receiver Setup:	Frequency	Detector	RBW	VBW	Remark
	0.009MHz-0.090MHz	Peak	10kHz	30kHz	Peak
	0.009MHz-0.090MHz	Average	10kHz	30kHz	Average
	0.090MHz-0.110MHz	Quasi-peak	10kHz	30kHz	Quasi-peak
	0.110MHz-0.490MHz	Peak	10kHz	30kHz	Peak
	0.110MHz-0.490MHz	Average	10kHz	30kHz	Average
	0.490MHz -30MHz	Quasi-peak	10kHz	30kHz	Quasi-peak
	30MHz-1GHz	Quasi-peak	100 kHz	300kHz	Quasi-peak
	Above 1GHz	Peak	1MHz	3MHz	Peak
Peak		1MHz	10Hz	Average	
Limit:	Frequency	Field strength (microvolt/meter)	Limit (dBuV/m)	Remark	Measurement distance (m)
	0.009MHz-0.490MHz	2400/F(kHz)	-	-	300
	0.490MHz-1.705MHz	24000/F(kHz)	-	-	30
	1.705MHz-30MHz	30	-	-	30
	30MHz-88MHz	100	40.0	Quasi-peak	3
	88MHz-216MHz	150	43.5	Quasi-peak	3
	216MHz-960MHz	200	46.0	Quasi-peak	3
	960MHz-1GHz	500	54.0	Quasi-peak	3
	Above 1GHz	500	54.0	Average	3
<p>Note: 15.35(b), Unless otherwise specified, the limit on peak radio frequency emissions is 20dB above the maximum permitted average emission limit applicable to the equipment under test. This peak limit applies to the total peak emission level radiated by the device.</p>					

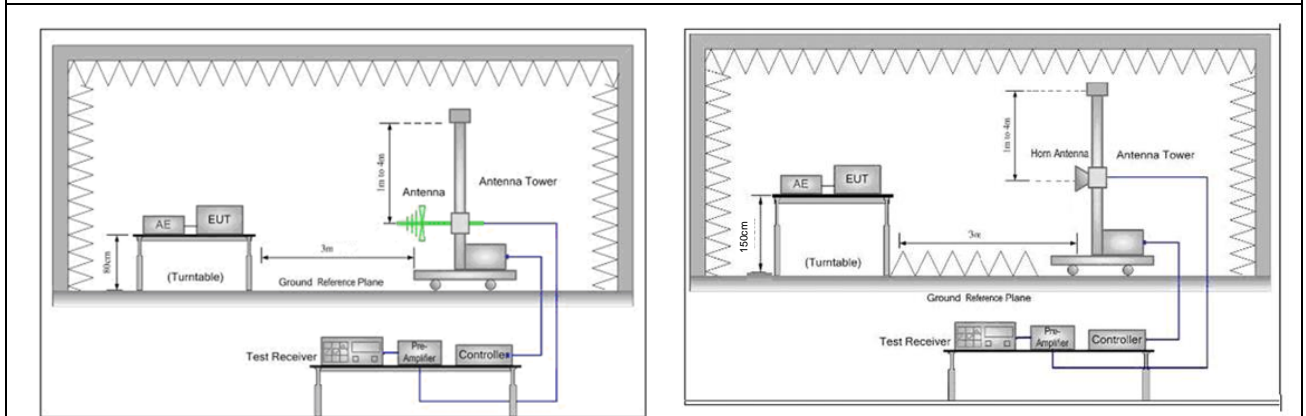
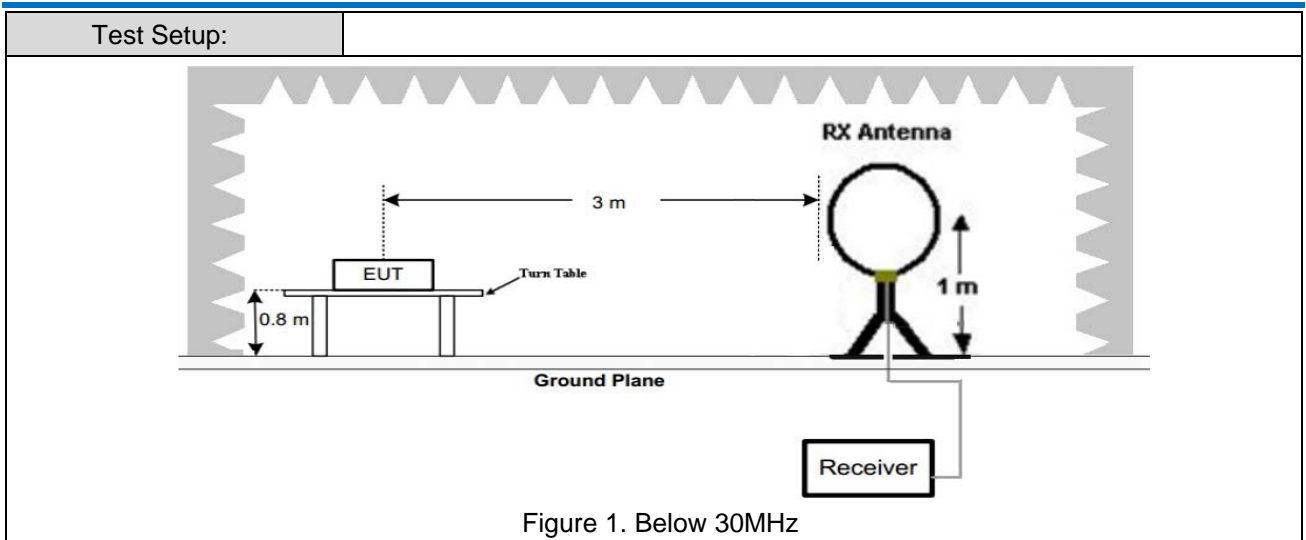

Test Procedure:

- a. 1) Below 1G: The EUT was placed on the top of a rotating table 0.8 meters above the ground at a 3 meter semi-anechoic chamber. The table was rotated 360 degrees to determine the position of the highest radiation.
 2) Above 1G: The EUT was placed on the top of a rotating table 1.5 meters above the ground at a 3 meter semi-anechoic chamber. The table was rotated 360 degrees to determine the position of the highest radiation.
 Note: For the radiated emission test above 1GHz:
 Place the measurement antenna away from each area of the EUT determined to be a source of emissions at the specified measurement distance, while keeping the measurement antenna aimed at the source of emissions at each frequency of significant emissions, with polarization oriented for maximum response. The measurement antenna may have to be higher or lower than the EUT, depending on the radiation pattern of the emission and staying aimed at the emission source for receiving the maximum signal. The final measurement antenna elevation shall be that which maximizes the emissions. The measurement antenna elevation for maximum emissions shall be restricted to a range of heights of from 1 m to 4 m above the ground or reference ground plane.
- b. The EUT was set 3 meters away from the interference-receiving antenna, which was mounted on the top of a variable-height antenna tower.
- c. The antenna height is varied from one meter to four meters above the ground to determine the maximum value of the field strength. Both horizontal and vertical polarizations of the antenna are set to make the

	<p>measurement.</p> <p>d. For each suspected emission, the EUT was arranged to its worst case and then the antenna was tuned to heights from 1 meter to 4 meters (for the test frequency of below 30MHz, the antenna was tuned to heights 1 meter) and the rotatable table was turned from 0 degrees to 360 degrees to find the maximum reading.</p> <p>e. The test-receiver system was set to Peak Detect Function and Specified Bandwidth with Maximum Hold Mode.</p> <p>f. If the emission level of the EUT in peak mode was 10dB lower than the limit specified, then testing could be stopped and the peak values of the EUT would be reported. Otherwise the emissions that did not have 10dB margin would be re-tested one by one using peak, quasi-peak or average method as specified and then reported in a data sheet.</p> <p>g. Test the EUT in the lowest channel (2402MHz),the middle channel (2440MHz),the Highest channel (2480MHz)</p> <p>h. The radiation measurements are performed in X, Y, Z axis positioning for Transmitting mode, and found the X axis positioning which it is the worst case.</p> <p>i. Repeat above procedures until all frequencies measured was complete.</p>
Exploratory Test Mode:	<p>Transmitting with GFSK modulation.</p> <p>Transmitting mode</p>
Final Test Mode:	<p>Transmitting with GFSK modulation.</p> <p>For below 1GHz part, through pre-scan, the worst case is the lowest channel of ANT 1.</p> <p>Only the worst case is recorded in the report.</p>
Test Results:	Pass

Radiated Emission below 1GHz		
30MHz~1GHz, the worst case		
Test mode:	Transmitting mode	Vertical

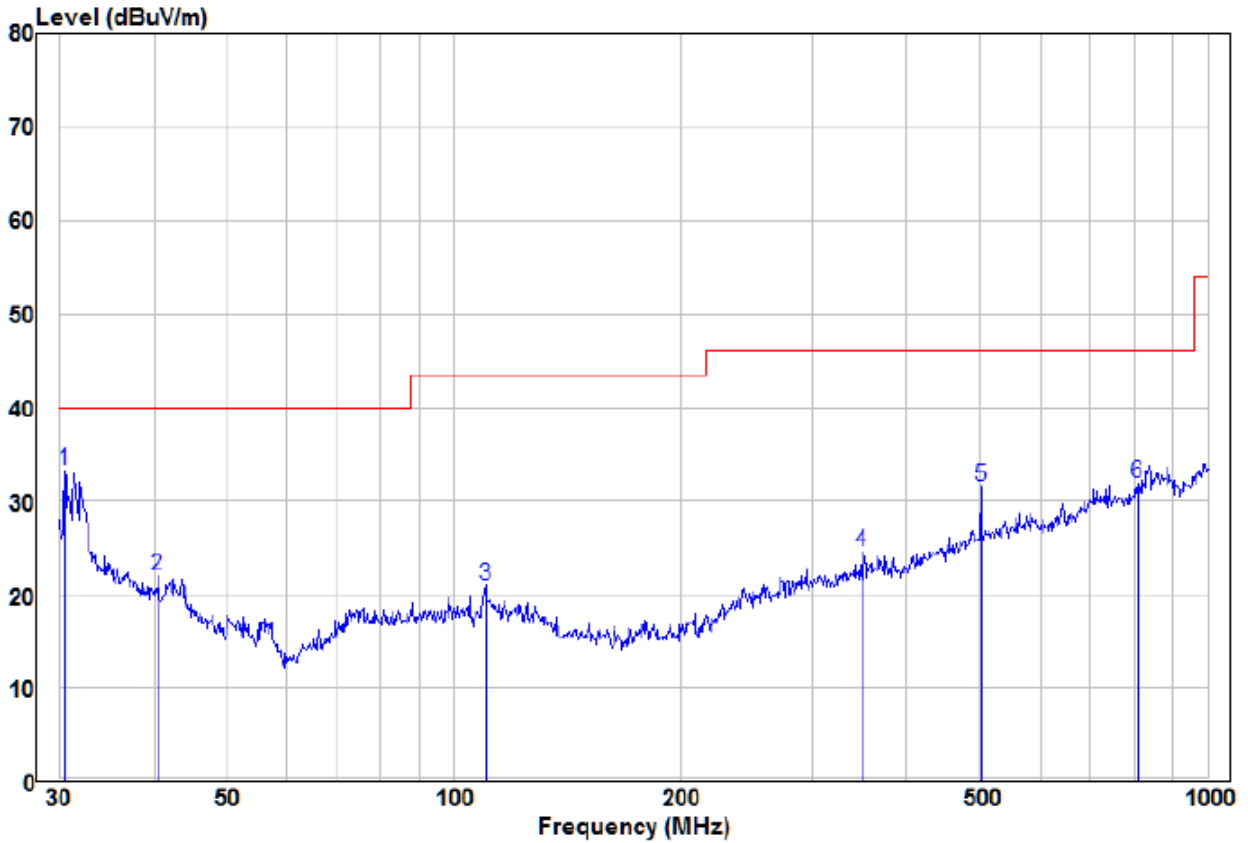

	Read Freq	Read Level	Factor	Limit Level	Over Limit	Remark	Pol/Phase		
	MHz	dBuV	dB/m	dBuV/m	dB				
1	pp	30.53	17.49	15.77	33.26	40.00	-6.74	Peak	VERTICAL
2		40.56	9.54	12.54	22.08	40.00	-17.92	Peak	VERTICAL
3		110.18	10.75	10.18	20.93	43.50	-22.57	Peak	VERTICAL
4		348.03	9.72	14.90	24.62	46.00	-21.38	Peak	VERTICAL
5		501.18	13.25	18.29	31.54	46.00	-14.46	Peak	VERTICAL
6		807.43	8.54	23.28	31.82	46.00	-14.18	Peak	VERTICAL

30MHz~1GHz, the worst case		
Test mode:	Transmitting mode	Horizontal

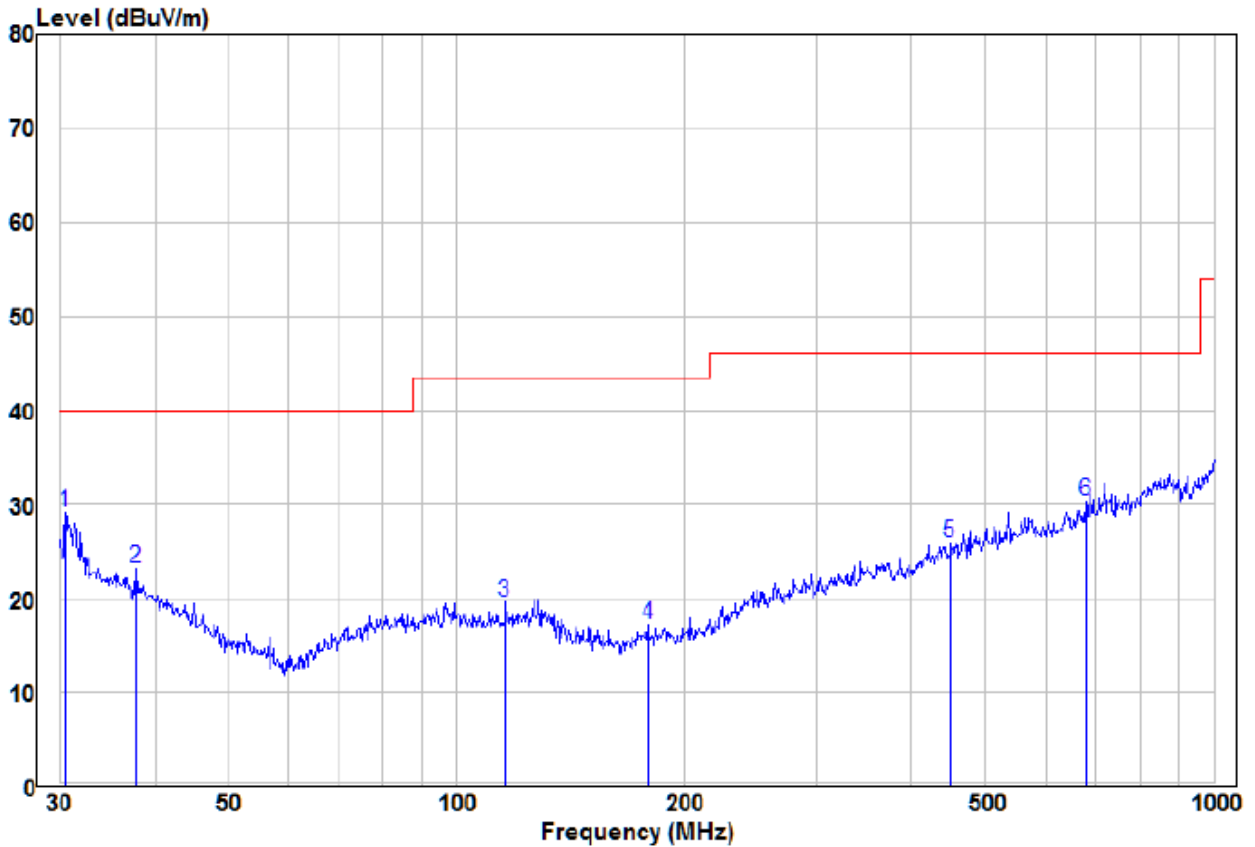

	Read Freq	Read Level	Factor	Limit Level	Limit Line	Over Limit	Remark	Pol/Phase	
	MHz	dBuV	dB/m	dBuV/m	dBuV/m	dB			
1	pp	30.53	13.47	15.77	29.24	40.00	-10.76	Peak	HORIZONTAL
2		37.81	9.59	13.59	23.18	40.00	-16.82	Peak	HORIZONTAL
3		116.13	9.07	10.50	19.57	43.50	-23.93	Peak	HORIZONTAL
4		179.39	8.90	8.30	17.20	43.50	-26.30	Peak	HORIZONTAL
5		449.56	9.29	16.72	26.01	46.00	-19.99	Peak	HORIZONTAL
6		677.58	10.22	20.18	30.40	46.00	-15.60	Peak	HORIZONTAL

Transmitter Emission above 1GHz

Worse case mode:		GFSK		Test channel:		Lowest	
Frequency	Meter Reading	Factor	Emission Level	Limits	Over	Detector Type	Ant. Pol.
(MHz)	(dBμV)	(dB)	(dBμV/m)	(dBμV/m)	(dB)		H/V
2390	54.97	-9.2	45.77	74	-28.23	Peak	H
2400	54.26	-9.39	44.87	74	-29.13	Peak	H
4804	52.10	-4.33	47.77	74	-26.23	Peak	H
7206	49.46	1.01	50.47	74	-23.53	Peak	H
2390	55.20	-9.2	46.00	74	-28.00	Peak	V
2400	52.11	-9.39	42.72	74	-31.28	Peak	V
4804	53.56	-4.33	49.23	74	-24.77	Peak	V
7206	51.03	1.01	52.04	74	-21.96	Peak	V

Worse case mode:		GFSK		Test channel:		Middle	
Frequency	Meter Reading	Factor	Emission Level	Limits	Over	Detector Type	Ant. Pol.
(MHz)	(dBμV)	(dB)	(dBμV/m)	(dBμV/m)	(dB)		H/V
4880	51.89	-4.11	47.78	74	-26.22	peak	H
7320	49.97	1.51	51.48	74	-22.52	peak	H
4880	52.58	-4.11	48.47	74	-25.53	peak	V
7320	49.62	1.51	51.13	74	-22.87	peak	V

Worse case mode:		GFSK		Test channel:		Highest	
Frequency	Meter Reading	Factor	Emission Level	Limits	Over	Detector Type	Ant. Pol.
(MHz)	(dBμV)	(dB)	(dBμV/m)	(dBμV/m)	(dB)		H/V
2483.5	54.98	-9.29	45.69	74	-28.31	Peak	H
4960	52.55	-4.04	48.51	74	-25.49	Peak	H
7440	49.75	1.57	51.32	74	-22.68	Peak	H
2483.5	57.16	-9.29	47.87	74	-26.13	Peak	V
4960	49.80	-4.04	45.76	74	-28.24	Peak	V
7440	48.85	1.57	50.42	74	-23.58	Peak	V

Remark:

- The field strength is calculated by adding the Antenna Factor, Cable Factor & Preamplifier. The basic equation with a sample calculation is as follows:
Final Test Level = Receiver Reading + Antenna Factor + Cable Factor – Preamplifier Factor
- Scan from 9kHz to 25GHz, the disturbance above 10GHz and below 30MHz was very low. As shown in this section, for frequencies above 1GHz, the field strength limits are based on average limits. However, the peak field strength of any emission shall not exceed the maximum permitted average limits specified above by more than 20 dB under any condition of modulation. So, only the peak measurements were shown in the report.

6 Photographs - EUT Test Setup

6.1 Radiated Spurious Emission

9KHz~30MHz:



30MHz~1GHz:

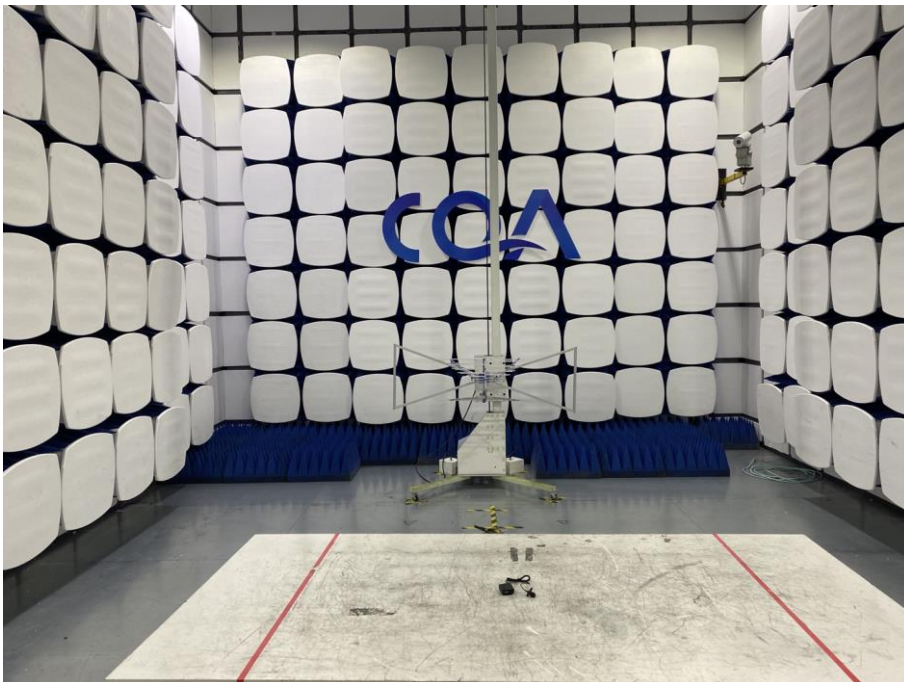

Above 1GHz:



7 Photographs - EUT Constructional Details

Test Model No.: LARK 150

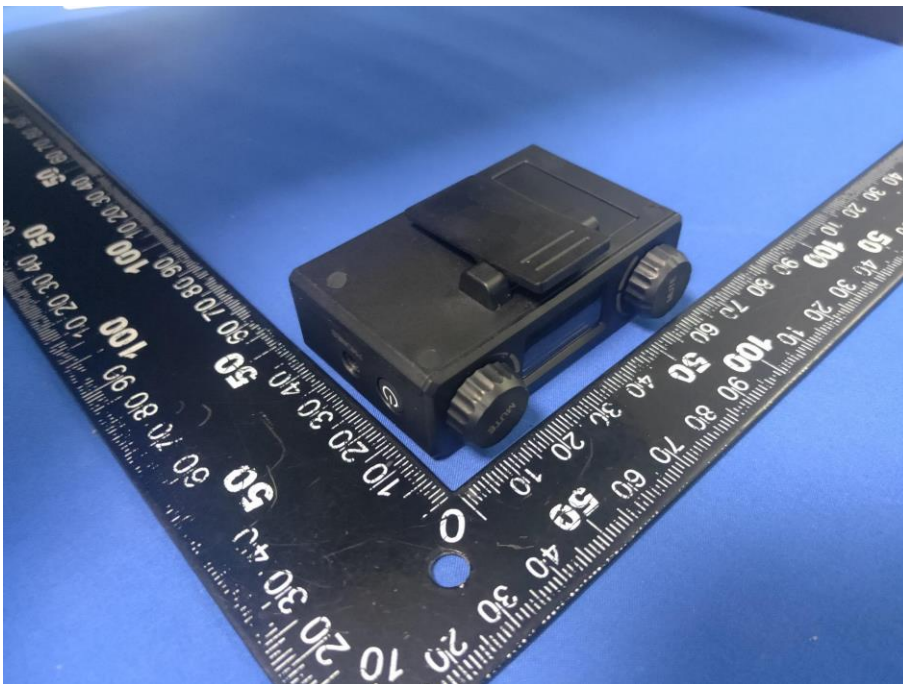
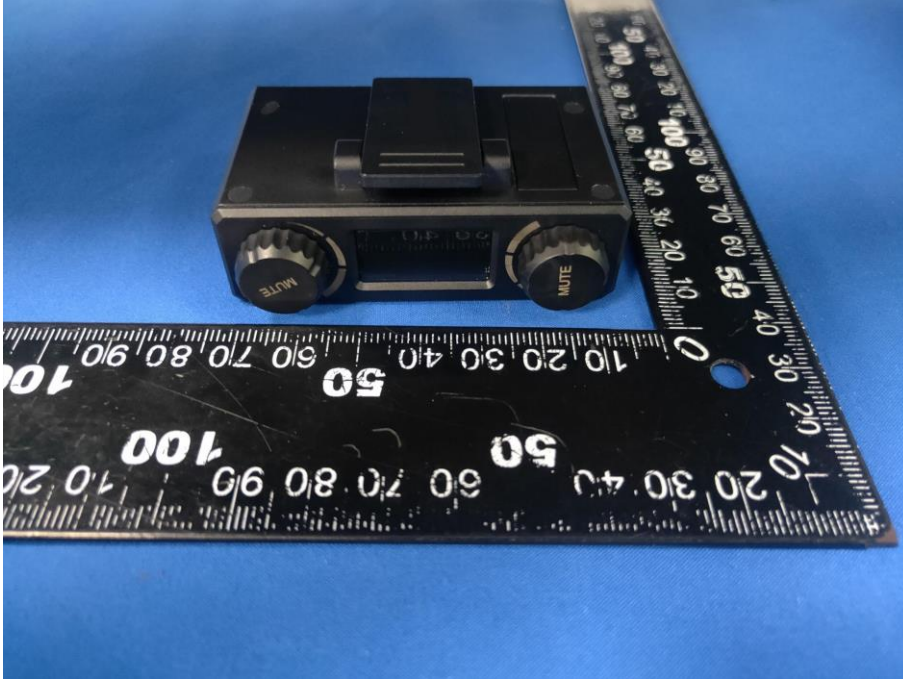



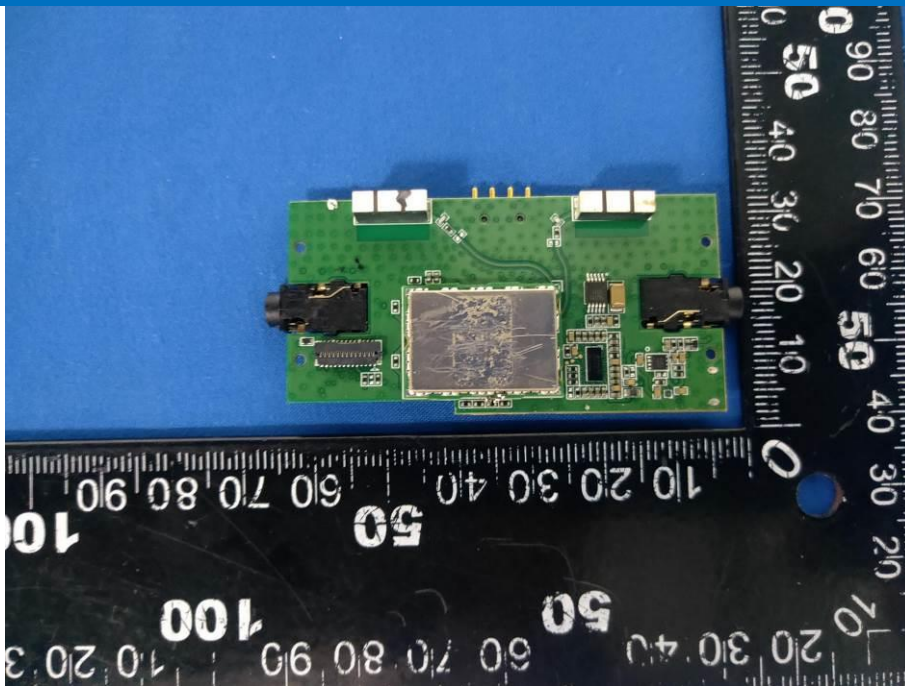

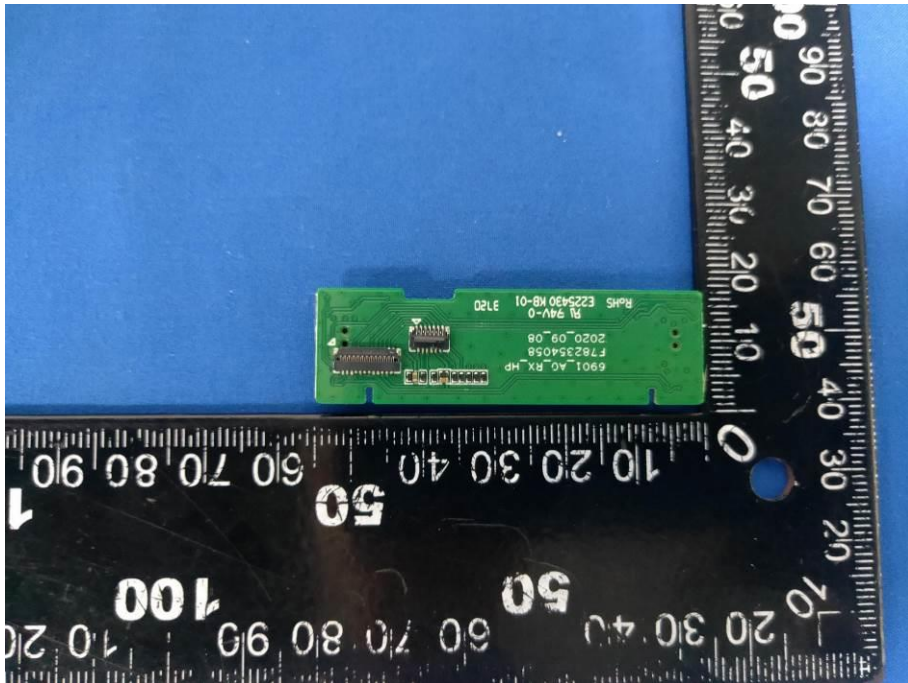
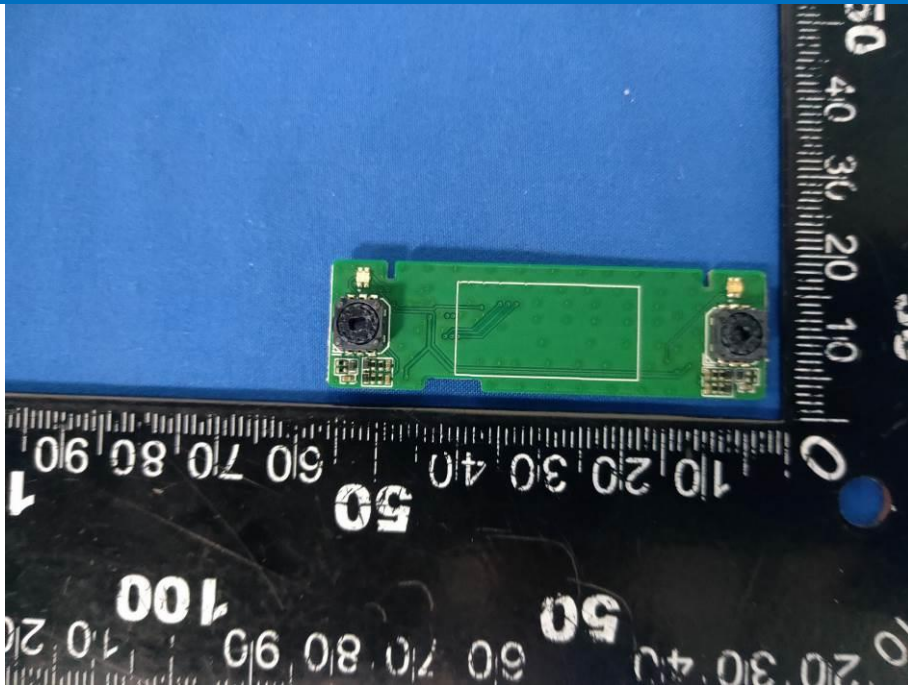



The End