

# MARS T1000

User Manual

## DESCRIPTION

Thank you for purchasing Hollyland MARS T1000 full-duplex wireless intercom system. With the DECT protocol technology, MARS T1000 is widely used in the areas of studio, stage events, EFP, webcasting, filmmaking etc. With a clean line of sight (LOS), the transmission range of MARS T1000 reaches up to 300m with full-duplex wireless communication and carrier-grade voice quality.

## KEY FEATURES

- 1000ft Communication Range, Carrier-Grade Voice Quality
- 1.9GHz Frequency Bandwidth
- Full-Duplex Wireless Communication
- Built-In Lithium Batteries, with Longer than 8 Hours Run Time on a Full Charge (Beltpacks)
- Up to 4 Beltpacks Communication Simultaneously (Base Station)
- 3.5mm Headset and 4-Pin Analog Audio Connection (Base Station)
- Base Station Support 7-36V DC Wide Voltage Input
- USB Firmware Upgrade
- Industrial Metal Case, Stable and Reliable

## DESCRIPTION

### ■ APPLICATIONS

- Filmmaking
- Live Broadcasting
- Corporate Events
- Production Crew Communication
- Stage Activities
- Emergency Dispatch
- Webcasting

# PACKING LIST

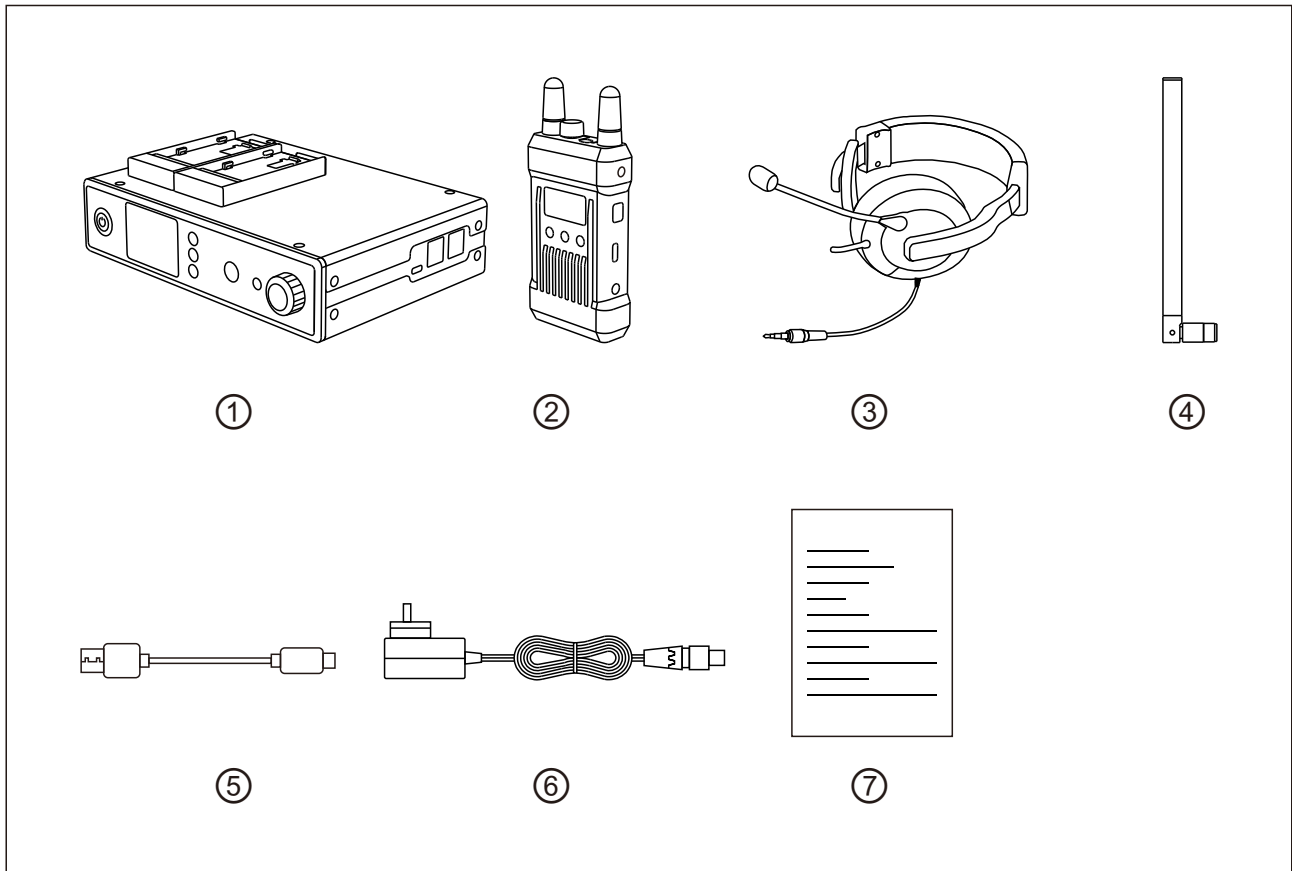

① Base Station	x1
② Beltpack	x4
③ Professional Dynamic Side-Ear Headset	x5
④ 1.9G High-Gain Base Station Antenna	x3
⑤ Type-C Cable	x4
⑥ 4-Pin XLR Adaptor	x1
⑦ Quick Guide	x1

# PACKING LIST

## OPTIONAL ACCESSORIES:

(Not included in the standard packing list)

- Headset
  - Professional Electret Side-Ear Headset
  - Side-Ear Mobile Earphone
  - Air Duct Earphone
  - Earmuffs
  - Professional Dynamic Double-Sided Headset
- TALLY Cable
  - TALLY Set (TALLY Switcher, Connector, External TALLY Light)
- Antennas
  - Dual polarization high-gain panel antenna
  - Antenna Extender
- Packing
  - Hard Case Package
- Installation
  - Base Station Ear Hanger
  - Beltpack Cold Shoe
- Charger
  - 5-Port USB Beltpacks Charger (Can be configured to Chinese, US, UK, EU and Australian standard)
- Cascade Accessories
  - 4-Wire to 2-Wire Converter Set
  - Ethernet to XLR Cable
  - 3.5mm to XLR Cable

## STANDARD SETUP

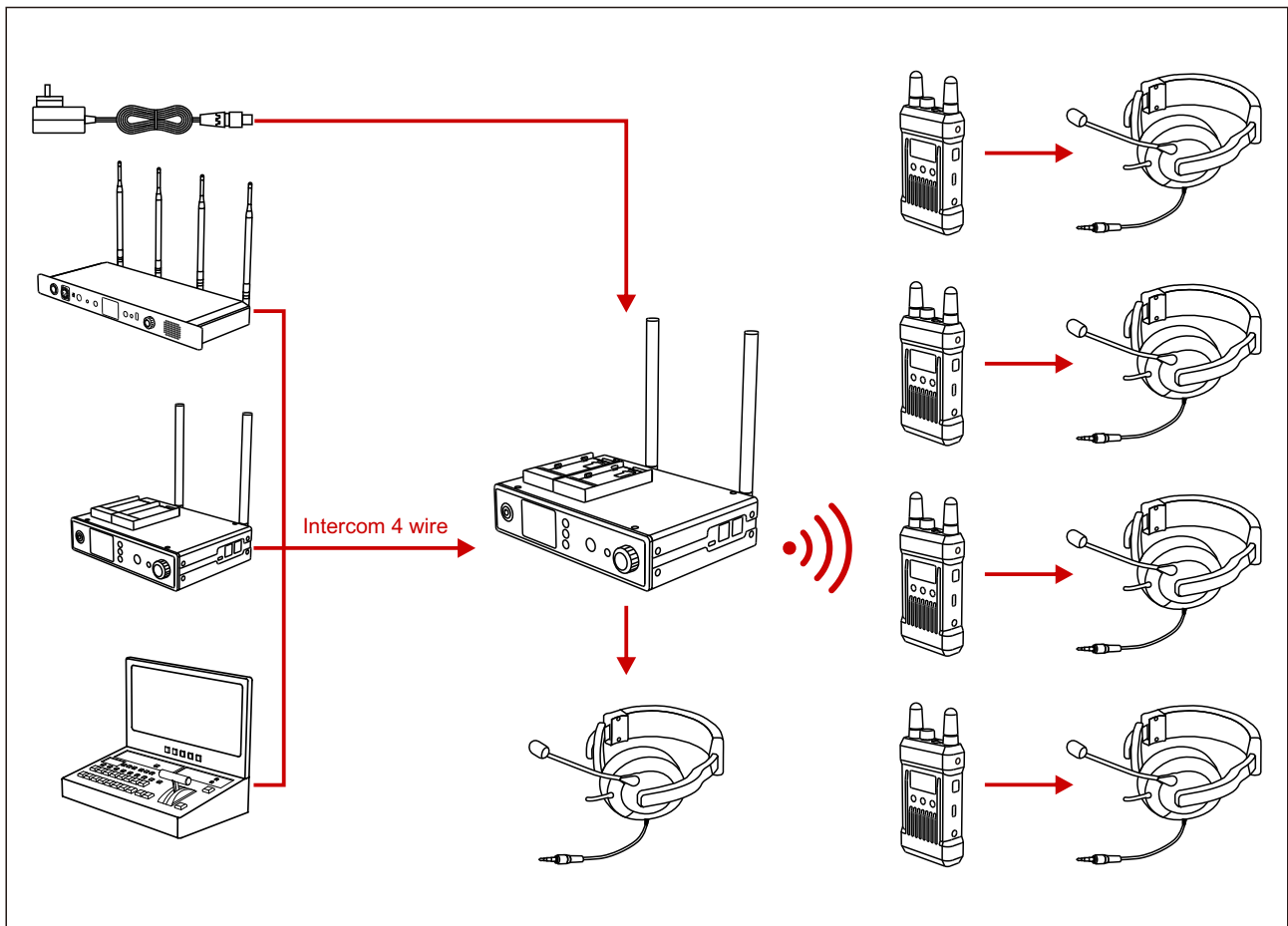

The base station of this wireless full-duplex intercom system supports up to 4 beltpacks. The base station and the beltpacks support dynamic and electret mics. They could be switched by selecting different applications in the menu. The 4-pin audio interface on the base station enables the device to connect with other audio systems, which can increase the quantity of beltpacks and also the wireless communication range.

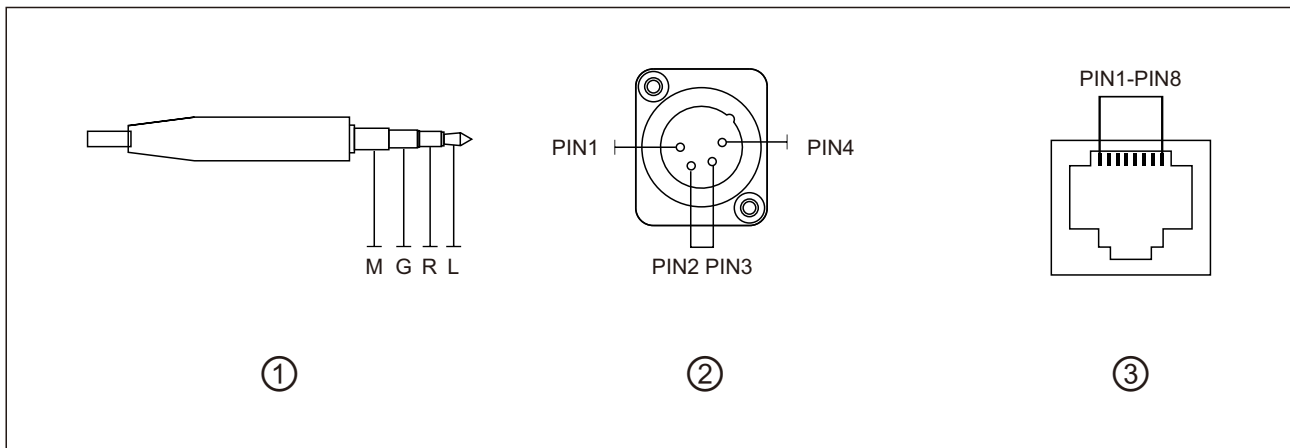

## ① 3.5mm Earphone

Interface: M G R L

Mic Impedance: 600

Speaker Impedance: 32

## ② DC Power Supply

Power Supply Range: 7~36V DC

Pin 1: GND

Pin 2: NULL

Pin 3: NULL

Pin 4: POWER

## ③ Intercom 4-Wire

Input Impedance: 10K

Pin 1: NULL

Pin 2: NULL

Pin 3: AUDIO OUT+

Pin 4: AUDIO IN+

Pin 5: AUDIO IN-

Pin 6: AUDIO OUT-

Pin 7: GND

Pin 8: GND

# PRODUCT INTERFACES

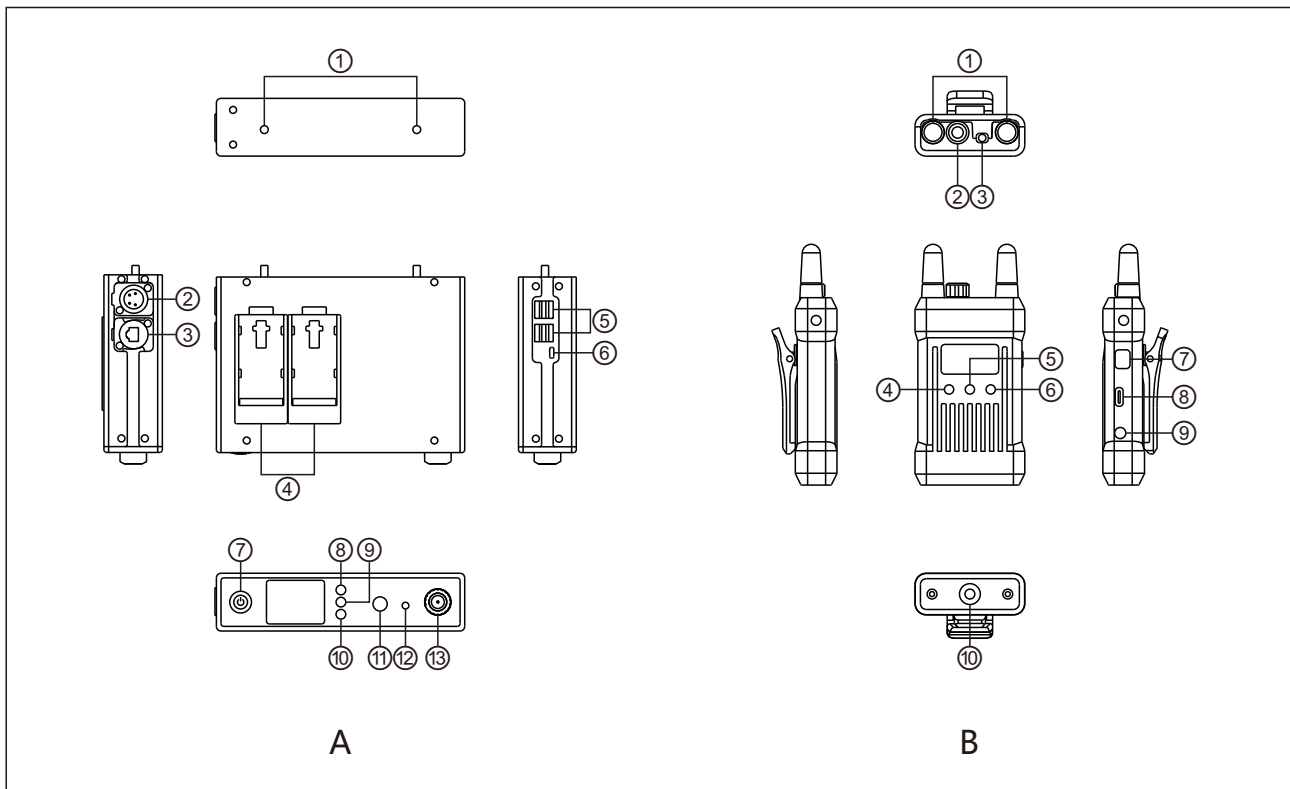

## A BASE STATION

- ① RF Antenna Interfaces
- ② DC Power Supply (4-Pin XLR Male)
- ③ 4-Pin Audio Input / Output (RJ45)
- ④ F970 Battery Plate
- ⑤ 4 USB Type-A Interfaces (For Beltpacks Charging and Cable Connection)
- ⑥ Type-C USB Debugging Interface
- ⑦ Power Switch
- ⑧ Up/Left Button
- ⑨ Menu/Confirm Button (Long Press to Enter Menu/Click to Confirm)
- ⑩ Down/Right Button
- ⑪ Remote Beltpack Mic Mute Button
- ⑫ 3.5mm Headset Interface
- ⑬ Base Station Volume Control Knob

## B BELTPACK

- ① Antennas Interfaces
- ② Power and Volume Control Knob
- ③ 3.5mm Headset Interface
- ④ Up/Left Button
- ⑤ Menu/Confirm Button (Long Press to Enter Menu /Click to Confirm)
- ⑥ Down/Right Button
- ⑦ Mute/Talk Switch Button (Double Click to Mute/Long Press to Talk)
- ⑧ Type-C USB Interface (For beltpacks Charging and Cable Connection)
- ⑨ 3-Segment 3.5mm TALLY Output Interface
- ⑩ 1/4 Screw Hole



# OLED DISPLAY

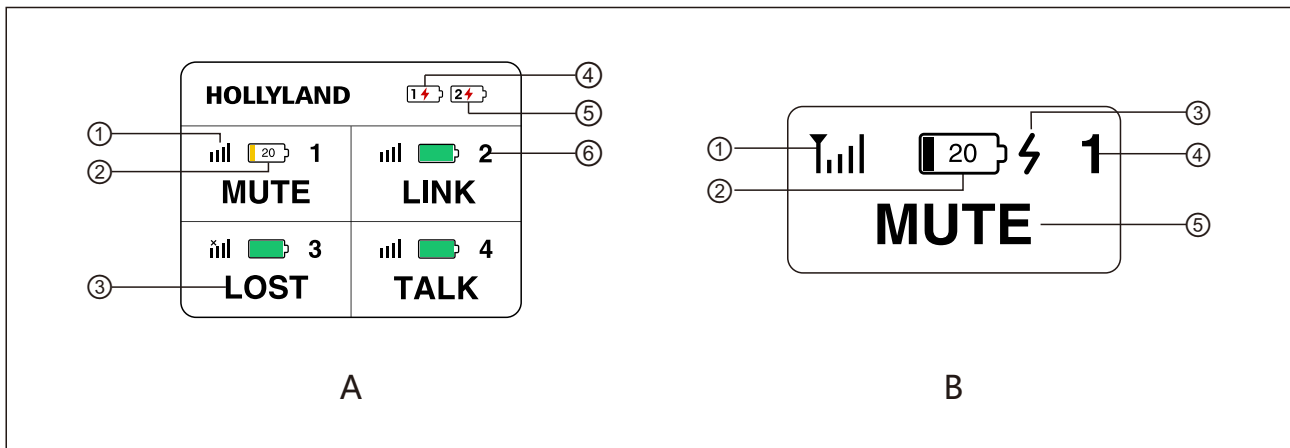

## A BASE STATION

- ① Beltpack Signal Strength
- ② Beltpack Real-Time Battery Status  
(Actual percentage will be displayed when the battery is lower than 20%)
- ③ Beltpack Current Status
- ④ F970 Battery 1 Low Battery Indicator
- ⑤ F970 Battery 2 Low Battery Indicator
- ⑥ Beltpack Number

## B BELTPACK

- ① Beltpack Signal Strength
- ② Beltpack Real-Time Battery Status  
(Actual percentage will be displayed when the battery is lower than 20%)
- ③ Battery Charging Indicator
- ④ Beltpack Number
- ⑤ Beltpack Current Status

# BASE STATION MENU FUNCTION INTRODUCTION

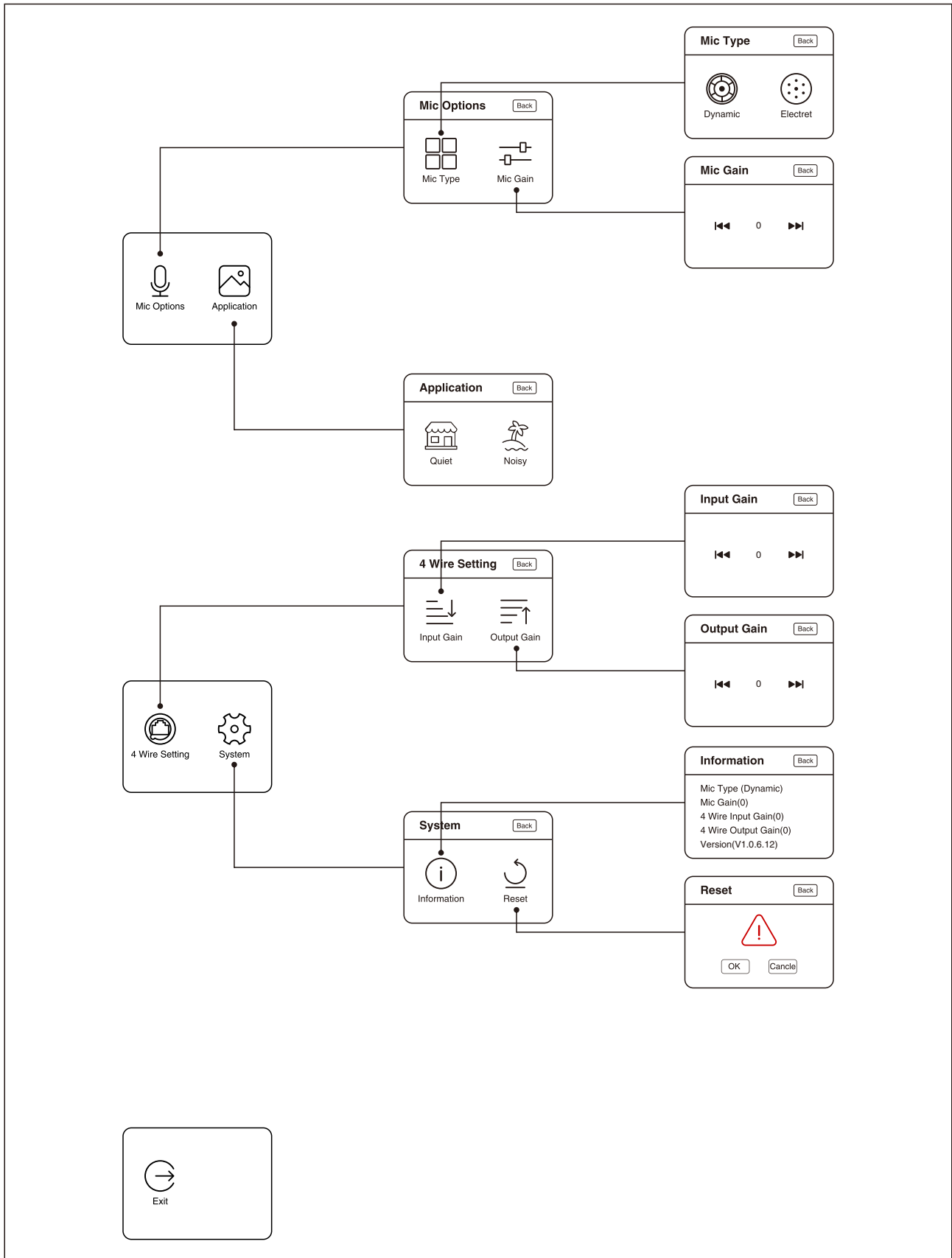

# BASE STATION MENU FUNCTION INTRODUCTION

Long press the Menu/Confirm/OK button for about three seconds to enter the root menu, select the folder and press "OK" to enter the next menu. Each menu feature is introduced as follows.

## **1 Select "Mic Options" and press "OK" button to enter the secondary menu of Mic Setting**

1.1. Select "Mic Type" and press "OK" to enter the third-level menu of Mic Setting;

1.1.1. Select "Dynamic" and press "OK" to switch to dynamic mic mode;

1.1.2. Select "Electret" and press "OK" to switch to electret mic mode;

1.2. Select "Mic Gain" and press "OK" to enter the third-level menu of Mic Gain Control;

1.2.1. Increase the mic gain, the beltpack will hear more sound while decrease the mic gain, the beltpack will hear less sound.

## **2 Select "Application" and press "OK" to enter the secondary menu of scene mode setting**

2.1. Select "Quiet" and press "OK" when in a quiet environment;

2.2. Select "Noisy" and press "OK" when in a noisy environment.

## **3 Select "4 Wire Setting" and press "OK" to enter the secondary menu of 4 wire audio setting**

3.1. Select "Input Gain" and press "OK" to enter the third-level menu of input gain adjustment;

3.1.1. Increase the gain, the 4 wire input sound will increase accordingly, and vice versa;

3.2. Select "Output Gain" and press "OK" to enter the third-level menu of output gain adjustment;

3.2.1. Increase the gain, the 4 wire output sound will increase accordingly, and vice versa.

## BASE STATION MENU FUNCTION INTRODUCTION

### **4 Select “System” and press “OK” to enter the secondary menu of system setting**

4.1. Select “Information” and press “OK” to enter the third-level menu of Information inquiry;

4.1.1. “Mic Type” displays the current mic type;

4.1.2. “Mic Gain” displays the current mic gain;

4.1.3. “Input Gain” displays the current 4 wire input gain;

4.1.4. “Output Gain” displays the current 4 wire output gain;

4.1.5. “Version” displays the current firmware version number;

4.2. Select “Reset” and press “OK”, the confirmation alert to restore to factory setting will pop up on the screen;

4.2.1. Select “OK” and press “OK” to delete all beltpacks registration information and the base station will be restored to default setting.

### **5 Select “Exit” and press “OK” to return to the root menu**

# BELTPACK MENU FUNCTION INTRODUCTION

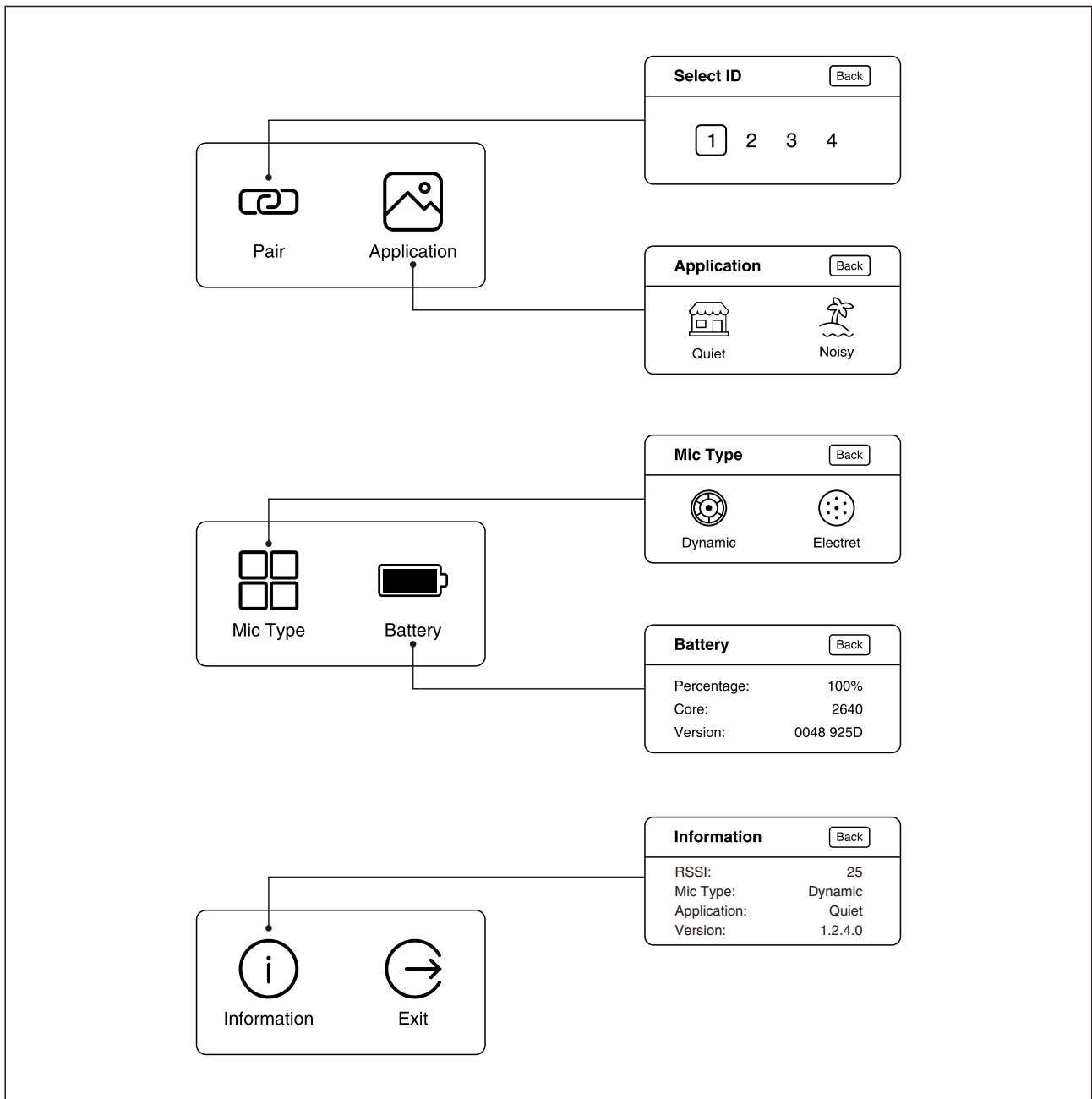

Long press the "OK" button for about three seconds to enter the root menu, select the menu and press "OK" to enter the next level. Each menu feature is described as follows.

# BELTPACK MENU FUNCTION INTRODUCTION

## **1 Select “Pair” and press “OK” button to enter the secondary menu of the registration feature**

1.1. Connect the beltpack with the base station with a USB cable and select any ID from 1 to 4 then press “OK” to register the beltpack. “Pairing...” will be displayed on the main interface of the beltpack and the base station. Unplug the USB cable after “Pairing Successful” is displayed on the screen of both of them.

## **2 Select “Application” and press “OK” to enter the secondary menu of scene mode configuration**

2.1. Select “Quiet” and press “OK” when in a quiet environment;

2.2. Select “Noisy” and press “OK” when in a noisy environment.

## **3 Select “Mic Type” and press the “OK” to enter the secondary menu of mic type selection**

3.1. Select “Dynamic” and press “OK” to switch to the dynamic mic mode;

3.2. Select “Electret” and press “OK” to switch to the electret mic mode.

## **4 Select “Battery” and press “OK” to enter the secondary menu of the battery information interface**

4.1. “Percentage” displays the current power percentage;

4.2. “Core” displays the current battery cell core version;

4.3. “Version” displays the current firmware version.

## **5 Select “Information” and press “OK” button to enter the secondary menu of system information inquiry**

5.1. “RSSI” displays the current wireless signal strength;

5.2. “Mic Type” displays the current mic type setting;

5.3. “Application” displays the current scene mode setting;

5.4. “Version” displays the current firmware version.

## **6 Select “Exit” and press “OK” to return to the root menu**

# INSTALLATION

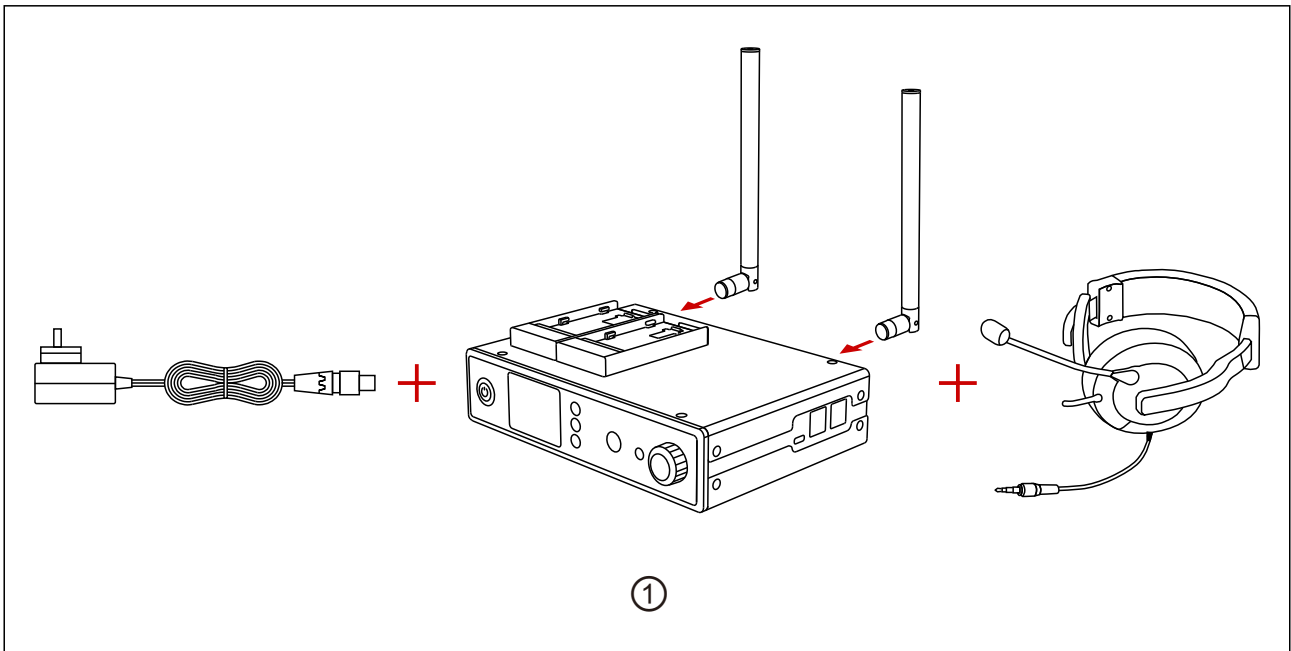

## ① Base Station Installation

1. Install antennas as demonstrated.
2. Connect the power adapter and the headset.
3. Press the power switch to power it on.

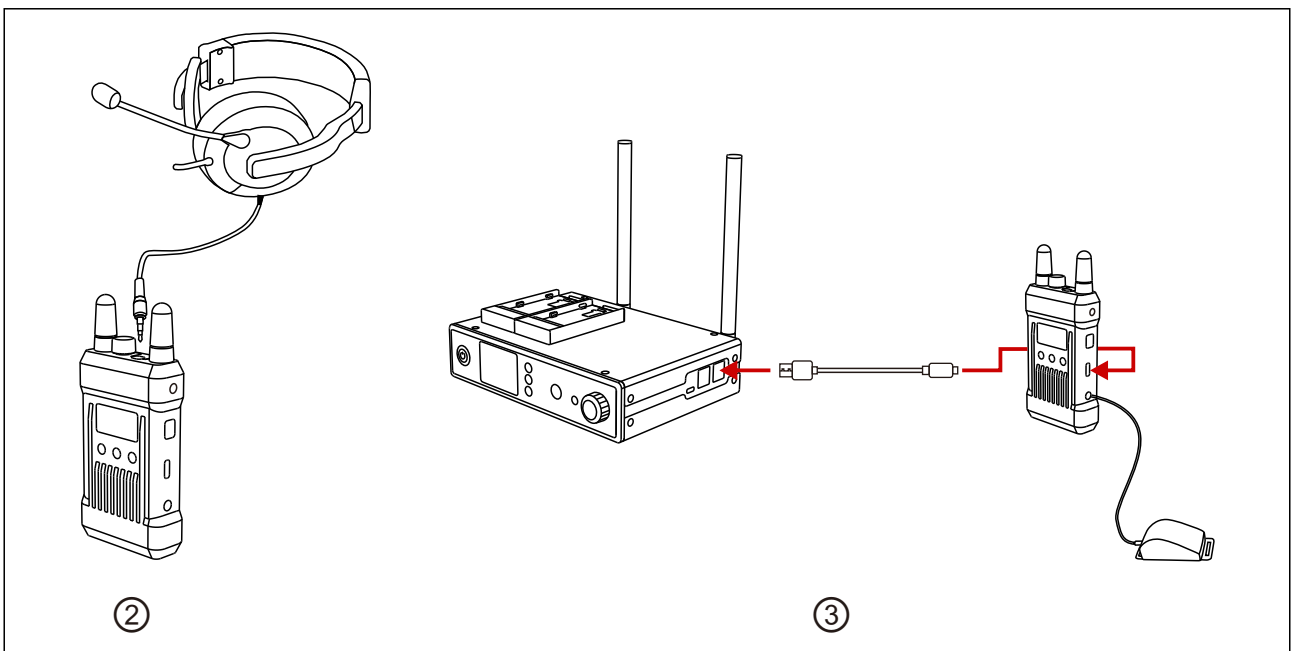

## ② Beltpack Installation

1. Connect headset as demonstrated.
2. Turn the power and volume control knob to turn on the beltpack.
3. When the status of the beltpack turns from “LOST” to “MUTE”, long press the “MUTE/TALK” button on the side of the beltpack to switch it to “TALK” mode to communicate. If the beltpack operator doesn’t want to talk with the base station, double click the “MUTE/TALK” button on the side of the beltpack to switch to “MUTE” mode. The beltpack operator can still hear the base station and other connected beltpacks under this mode.
4. Click the “REMOTE MIC KILL” button to mute all beltpacks if the base station operator doesn’t want to hear from all beltpacks. When the indicator light is on, all beltpacks are switched to “MUTE” mode. Under this mode, beltpacks’ operators can hear the base station but they cannot talk to each other and to the base station. If a beltpack operator wants to communicate with the base station, long press the “MUTE/TALK” button on the side of the beltpack to call the base station. The “REMOTE MIC KILL” button on base station will flash with a red light. Click the “REMOTE MIC KILL” button again to enable all beltpacks to switch back to “TALK” mode.
5. The default setting of mic is dynamic mic. Users can choose different types of mics based on different applications. Long press the menu button to enter the interface of mic setting and change the mic type to electret.
6. When connected with other intercom systems by 4 wire audio interfaces, users can enter the root menu and adjust input/output gain to reach gain balance for the whole intercom system.
7. Due to the noise differences in different applications, it may take some white noise to have better hearing experience. The background noise level can be adjusted by changing the “Application” in the root menu.
8. It is recommended that the users completely discharge the beltpack using the beltpack three times before, Since the battery has been in hibernation after a period of time.



# INSTALLATION

## ③ Repairing

If any beltpack ID is lost while using the system resulted by incorrect operation or other reasons, connect the base station and the beltpack through the standard USB type-C data cable. Enter the pair menu and selects a master station vacancy ID for registration on the beltpack. “Pairing...” will appear on the main interface of the base station and the beltpack. Wait until “Pairing Successful” is displayed on the screen of both the base station and the beltpack before unplugging the cable. The beltpack will then be ready to use again.

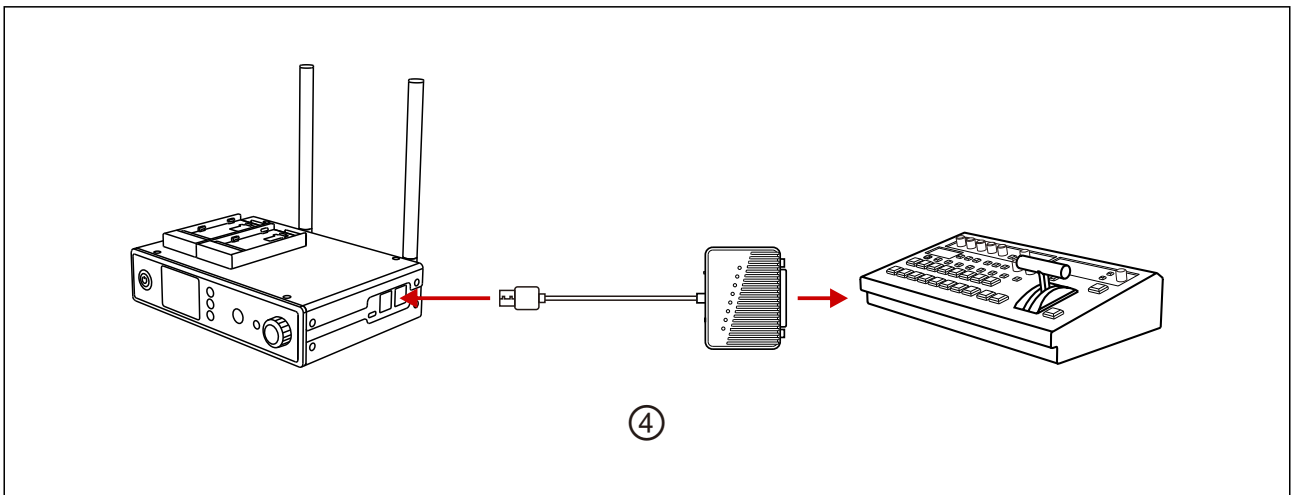

## ④ TALLY Features

TALLY universal signal converter is an optional accessory available on the market. It can help the product achieve the TALLY distribution feature. Please find the detailed user guide in the TALLY Universal Signal Converter Quick Guide.

# PARAMETERS

	Base Station	Beltpack
<b>Interface</b>	2Antenna Interfaces 4-Pin XLR Male DC Input 3.5mm Headset Interface RJ45 Interface 4 wire audio interface USB Type-C Interface Double USB Type-A Interfaces	2Antenna Interfaces 3.5mm Headset Interface 3.5mm TALLY Output Interface USB Type-C Interface
<b>Power Supply Mode</b>	7~36V DC; F970 Battery (Typical)	1600mAh Polymer Lithium Battery
<b>Frequency Response</b>	300Hz to 4KHz	300Hz to 4KHz
<b>Signal to Noise Ratio</b>	> 50dB	> 50dB
<b>Distortion</b>	< 2%	< 2%
<b>Transmission Range</b>	300m Between Beltpack and Base Station	300m Between Beltpack and Base Station
<b>Frequency Bandwidth</b>	CE: 1881.792MHz-1897.344MHz; FCC: 1921.536MHz-1928.448MHz	
<b>Modulation Mode</b>	GFSK	GFSK
<b>Transmission Power</b>	CE:Maximum 21.4dBm FCC: Maximum18.43dBm	CE:Maximum 16.4dBm FCC: Maximum20.61dBm
<b>Receiver Sensitivity</b>	≤ -93dBm	≤ -93dBm
<b>Bandwidth</b>	1.728MHz	1.728MHz
<b>Power Consumption</b>	< 35W	< 6W
<b>Dimension</b>	(L*W*H): 220*170*50mm	(L*W*H): 100*58*22mm
<b>Net Weight</b>	1400g	180g
<b>Temperature Range</b>	0~+40°C(working status) -20~+60°C(storage condition)	0~+40°C(working status) -20~+60°C(storage condition)

### ■ SAFETY NOTE

Do not place your beltpacks on heating equipment, cooking equipment, high-pressure containers (such as microwave ovens, induction cookers, electric ovens, heaters, pressure cookers, water heaters, gas stoves, etc.) to prevent the battery from overheating and exploding. The original mating type of charger, data cable, and battery must be used. Chargers, data cables, or batteries that are not certified by the manufacturer or not the companion model may cause electric shock, fire, explosion, or other hazards.

### ■ POOR AUDIO QUALITY

1. First confirm whether the beltpack antennas are correctly installed and tightened. If there is no improvement, replace the antennas.
2. Ensure that the beltpack and the base station are in the transmission range and there is no obstacle between the main station and the beltpack.
3. Check if the volume of the beltpack is too low and turn it to a comfortable level.
4. Due to the difference in impedance and setting bias, we generally don't recommend customers to use his own 4-stage 3.5mm headset. If the sound quality is poor, replace the headset.

### ■ BASE STATION CANNOT DISPLAY BELTPACK INFORMATION

1. First confirm whether the beltpack antennas are correctly installed and tightened. If there is no improvement, replace the antennas.
2. Check the status of the Beltpack. If "LOST" appears on the beltpack screen, make sure that the beltpack is within the transmission range from the base station.
3. Check the status of the beltpack. If it is displayed as "NULL", it means that the beltpack information is lost due to incorrect operation, and it needs to be reregistered.

## ■ NO SOUND BETWEEN THE BASE STATION AND BELTPACK

1. Confirm if the “REMOTE MIC KILL” button on the base Station is on. If the red light is on, click on it to turn it off.
2. Check the current status on the beltpack screen. If it’s on “MUTE”, long press the “MUTE/TALK” button on the side to switch it to “TALK”.
3. Check if the headset functions well and if you wear the headset and mic properly. (correct way: put the headset on the head with the mic less than 10cm from your mouth)

## ■ TALLY FUNCTION UNAVAILABLE

1. Confirm that the type of the switcher is correct. The TALLY interface definition is not unified on most switchers, so it will cause TALLY dysfunction;
2. Due to various types of the switcher, high-level value will work when push the level switch to “High” on the TALLY signal universal converter; low-level value will work when push the level switch to “Low” on the TALLY signal universal converter;
3. Confirm the ID of the beltpacks, and check if the TALLY converter connects with the USB Type-A interface on the base station correctly;
4. The beltpack only supports external TALLY light. Confirm if the beltpack connects to an external TALLY correctly;
5. DB25 INTERFACE AND TALLY INDICATOR WIRING RELATION TABLE

Channel	Program	Preview	GND
TALLY 1	PIN 1	PIN 14	PIN 13
TALLY 2	PIN 2	PIN 15	
TALLY 3	PIN 3	PIN 16	
TALLY 4	PIN 4	PIN 17	
TALLY 5	PIN 5	PIN 18	
TALLY 6	PIN 6	PIN 19	
TALLY 7	PIN 7	PIN 20	
TALLY 8	PIN 8	PIN 21	

## FCC WARNING

This device complies with part 15 of the FCC Rules. Operation is subject to the following two conditions:(1) This device may not cause harmful interference, and (2) this device must accept any interference received, including interference that may cause undesired operation.

Any Changes or modifications not expressly approved by the party responsible for compliance could void the user's authority to operate the equipment.

Note: This equipment has been tested and found to comply with the limits for a Class B digital device, pursuant to part 15 of the FCC Rules. These limits are designed to provide reasonable protection against harmful interference in a residential installation. This equipment generates, uses and can radiate radio frequency energy and, if not installed and used in accordance with the instructions, may cause harmful interference to radio communications. However, there is no guarantee that interference will not occur in a particular installation. If this equipment does cause harmful interference to radio or television reception, which can be determined by turning the equipment off and on, the user is encouraged to try to correct the interference by one or more of the following measures:

- Reorient or relocate the receiving antenna.
- Increase the separation between the equipment and receiver.
- Connect the equipment into an outlet on a circuit different from that to which the receiver is connected.
- Consult the dealer or an experienced radio/TV technician for help.

## FCC WARNING

### ■ FCC EXPOSURE TO RADIO FREQUENCY (RF) SIGNALS

For beltpack:

This is a radio transmitter and receiver. It is designed and manufactured not to exceed the emission limits for exposure to radio frequency (RF) energy set by the Federal Communications Commission (FCC) of the U.S. Government. These limits are part of comprehensive guidelines and establish permitted levels of RF energy for the general population. The guidelines are based on the safety standards previously set by both U.S. and international standards bodies. These standards include a substantial safety margin designed to assure the safety of all persons, regardless of age and health. This device and its antenna must not be colocated or operating in conjunction with any other antenna or transmitter. This product has been shown to be capable of compliance for localized specific absorption rate (SAR) for uncontrolled environment/general population exposure limits specified in ANSI/IEEE Std. C95.1-1992 and had been tested in accordance with the measurement procedures specified in FCC/OET Bulletin 65 Supplement C (2001) and IEEE 1528.

For Base station:

This equipment complies with FCC radiation exposure limits set forth for an uncontrolled environment. This equipment should be installed and operated with minimum distance 20cm between the radiator& your body.

### ■ MANUFACTURE

Company Name :Shenzhen Hollyland Technology Co.,Ltd

Address: Shenzhen Hollyland Technology Co.,Ltd 8F,Building 5D,Skyworth

Innovation Valley,Tangtou Road.Shiyan Street,Baoan District Shenzhen, China



 HollylandTech

 HollylandTech

 HollylandTech

 sales@Hollyland-tech.com

 www.hollyland-tech.com