



# **SOLIDCOM M1**

**User Manual**

V1.0.0



**HOLLYVIEW**

Powered by Hollyland

## FOREWORD

Thank you for purchasing Hollyland Full-Duplex wireless intercom system. Please read this instruction carefully before using the product. Wish you have a pleasant experience.

### ■ KEY FEATURES

- Carrier-Grade Voice Quality, up to 450 Meters Line-of-Sight Usage Distance
- 1.9GHz Frequency, Support Frequency Configuration in Different Regions
- Automatically Switching between External Omnidirectional Fiberglass Antenna and In-Built Panel Antenna
- Full-Duplex Wireless Communicating
- The Station Supports up to 8 Beltpacks to Talk at the Same Time. Station, App and Webserver Configuration Upgrade supported
- Beltpack Supports Simultaneous Calls in 3 Groups
- The Station Supports Cascading or Connecting with the 2/4 Wire Audio Systems
- Station's Power could be Supplied by POE Cascading or NP-F Type Batteries
- In-Built Lithium Battery for the Beltpacks, Usage for over 6 hours
- Portable Storage Charging Base, Easy to Carry
- 10 Levels Volume. Different Needs of Scenes Satisfied

# PACKING LIST

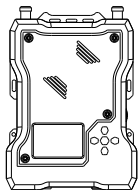

①



②

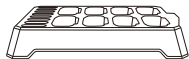

③



④



⑤

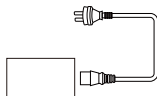

⑥



⑦



⑧



⑨



⑩



⑪



⑫

## 8-BELTPACK PACKAGE

① Station	x1
② Beltpack	x8
③ Charging Base	x1
④ High Gain Omnidirectional Antenna	x2
⑤ LEMO Single-Ear Headset	x8
⑥ POE Adapter	x1
⑦ RJ45 to XLR Transferring Cable (5 meters)	x1
⑧ USB-Type-A to Type-C Transferring Cable	x1
⑨ 4Pin XLR Adapter	x1
⑩ Battery for Beltpacks	x16
⑪ 3/8 Installing Accessory	x1
⑫ User Guide	x1

\* The exact quantity may vary on products configuration. Please take the actual quantity as standard.

## 4-BELTPACK PACKAGE

① Station	x1
② Beltpack	x4
③ Charging Base	x1
④ High Gain Omnidirectional Antenna	x2
⑤ LEMO Single-Ear Headset	x4
⑥ POE Adapter	x1
⑦ RJ45 to XLR Transferring Cable (5 meters)	x1
⑧ USB-Type-A to Type-C Transferring Cable	x1
⑨ 4Pin XLR Adapter	x1
⑩ Battery for Beltpacks	x8
⑪ 3/8 Installing Accessory	x1
⑫ User Guide	x1

\* The exact quantity may vary on products configuration. Please take the actual quantity as standard.

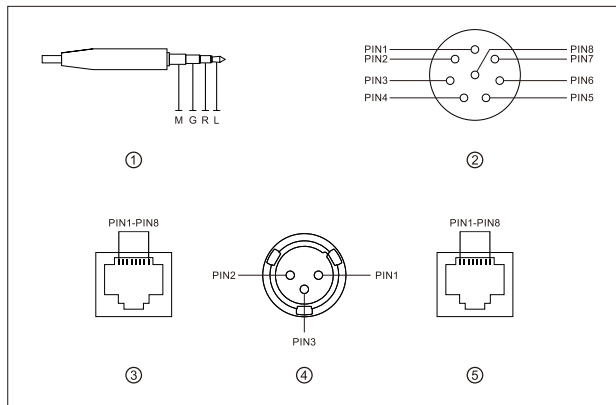

## ① 3.5mm Headset Interface

Interface Definition: M G R L

Microphone Independence: 600Ω

Speaker Independence: 32Ω

## ② LEMO Headset Interface

PIN1: GND

PIN2: GND

PIN3: SPK -

PIN4: SPK +

PIN5: MIC +

PIN6: MIC -

PIN7: NULL

PIN8: LED



### ③ 4-Wire Interface

Input Independence: 10K $\Omega$

PIN1: NULL

PIN2: NULL

PIN3: AUDIO OUT+

PIN4: AUDIO IN+

PIN5: AUDIO IN-

PIN6: AUDIO OUT-

PIN7: GND

PIN8: GND

### ④ 2-Wire Interface

PIN1: GND

PIN2: POWER

PIN3: AUDIO

### ⑤ POE/PWR Interface

PIN1: -POWER

PIN2: -POWER

PIN3: +POWER

PIN4: +POWER

PIN5: +POWER

PIN6: +POWER

PIN7: -POWER

PIN8: -POWER

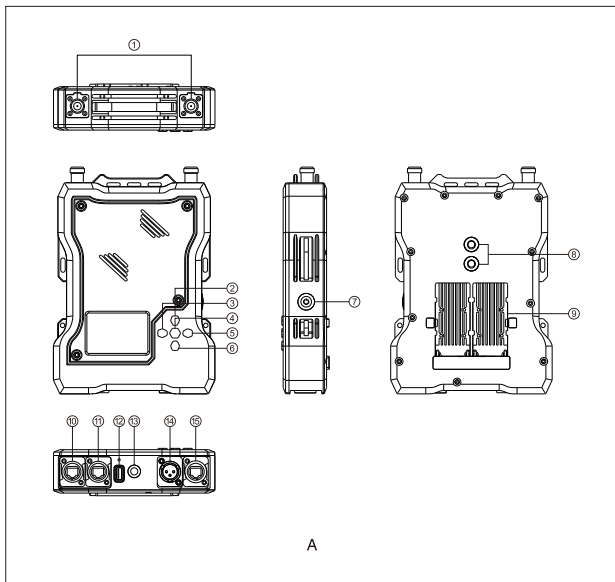

### **A** STATION

- ① Antenna Interface
- ② Up Key
- ③ Left Key
- ④ Menu/Confirm Key (Long Press to the Menu/ Short Press to Select)
- ⑤ Right Key
- ⑥ Down Key
- ⑦ Power Button
- ⑧ 3/8 Screw Hole
- ⑨ Interface for NP-F Type Battery
- ⑩ Power Supply Interface
- ⑪ 4-Wire Audio Input-Output Interface (RJ45 Interface)
- ⑫ USB Interface
- ⑬ 3/8 Screw Hole
- ⑭ 2-Wire Audio Input-Output Interface
- ⑮ POE Interface

## PRODUCT INTERFACES

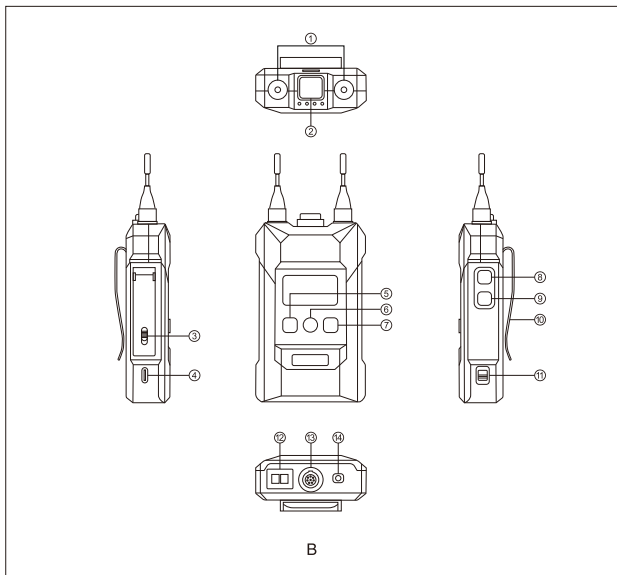

### **B** BELTPACK

- ① Antenna
- ② Mute/Talk Switch Key, Press Down for Talk, Up for Mute
- ③ Battery Compartment Switcher
- ④ USB Type-C Interface
- ⑤ Left Key/A Group Key(The beltpack is not grouped when the indicator light is off, The beltpack is joined Group A but unable to talk or listen when the Indicator light is cyan, The beltpack is able to talk and listen in Group A when the Indicator light is green)
- ⑥ Menu/ B Group Key (Long press to enter Menu/The beltpack is not grouped when the indicator light is off, The beltpack is joined Group B but unable to talk or listen when the Indicator light is cyan, The beltpack is able to talk and listen in Group B when the Indicator light is green)
- ⑦ Right Key/C Group Key(The beltpack is not grouped when the indicator light is off,The beltpack is joined Group C but unable to talk or listen when the Indicator light is cyan, The beltpack is able to talk and listen in Group C when the Indicator light is green)
- ⑧ Volume+ Button
- ⑨ Volume- Button
- ⑩ Back Clip
- ⑪ Power Switcher
- ⑫ Charging Contact
- ⑬ LEMO Headset Interface
- ⑭ 3.5mm Headset Interface

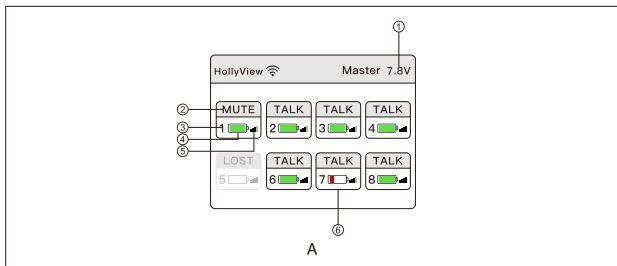

## A STATION MAIN DISPLAY INTRODUCTION

① Current Battery Voltage of Station

② Current Status of Beltpack

TALK: The beltpack is able to talk while listening.

MUTE: The beltpack is able to listen but unable to talk.

LOST: The beltpack is disconnected from the station.

LINK: The beltpack is linking to the station.

③ Beltpack Number

④ Current Battery Usage of Beltpack

⑤ Current Signal Strength of Beltpack

⑥ Low Battery Display of Beltpack

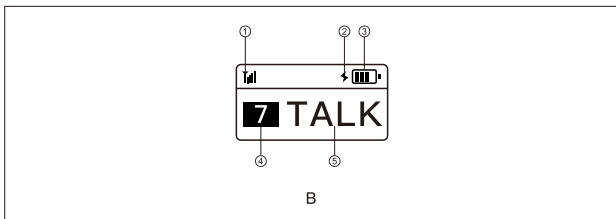

### **B** BELTPACK MAIN DISPLAY

- ① Current Signal Strength
- ② Charging Notice
- ③ Current Battery Usage
- ④ Beltack Number
- ⑤ Current Status

TALK: Able to Talk while Listening

MUTE: Able to Listen but unable to Talk

LOST: Disconnected from the Station

LINK: Linking to the Station

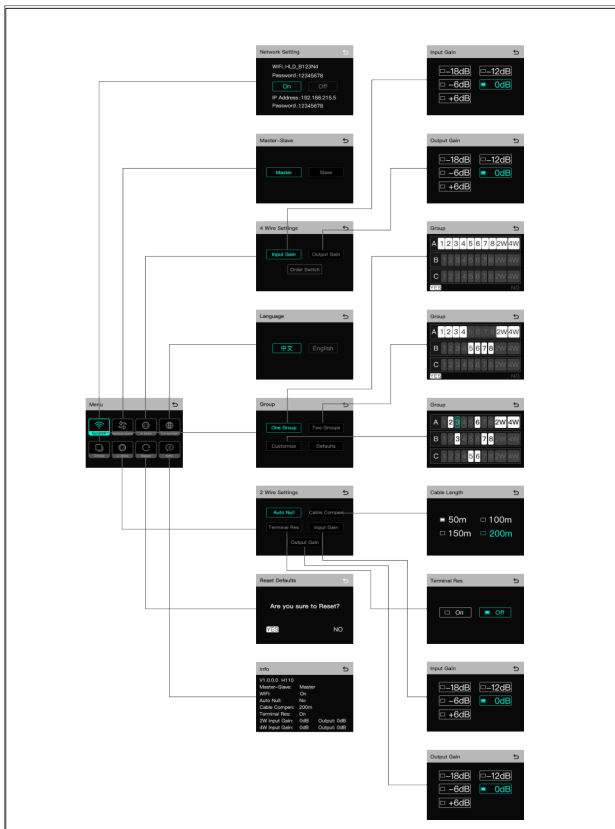



## STATION MENU INTRODUCTION

Long press Menu/Confirm Key for 3 Seconds to enter the Menu, following is the menu function's Introduction.

① **Select “Network” to Switch WiFi on/off, See the WiFi Password and IP Address.**

② **Select “Master and Slave” to Set the Station as Master Device/Slave Device.**

2.1 If there's only one kit of devices, the station needs to be set as Master Device; When two or more kits are cascaded, the station can be set as Master Device/ Slave Device.

2.2 When the station is set as Master Device, The beltack number will automatically switch to 1-8; When the station is set as Slave Device, The beltack number will automatically switch to 9-16.

2.3 This function can only be used when two kits of devices cascaded by Ethernet interface. The Station needs to be set as Master Device when only one kit of devices used.

③ **Select “4 Wire” Entering 4 Wire Audio Settings.**

3.1 Enter the Menu to adjust 4 Wire audio system input/output gain.

3.2 Switch sequence of line.

④ **Select “Language” to Switch Language to Chinese or English.**

⑤ **Select “Group” Entering Group Settings.**

5.1 One Group: To group all the beltacks, 2 Wire and 4 Wire audio devices to Group A. The indicator light of Group A Key on the beltacks will shine

5.2 Two Groups: To group number 1-4 beltacks, 2 Wire and 4 Wire audio devices to Group A, number 5-8 beltacks to Group B, The indicator light of corresponding groups on the beltacks will shine.

5.3 Customize: Able to group beltacks, 2 Wire or 4 Wire audio devices though Direction Keys and Confirm Key. After setting the corresponding indicator light of the beltack will shine;

5.4 Defaults: Able to group all beltacks, 2 Wire and 4 Wire to Group A, After setting the indicator light of Group A will shine.

## ⑥ Select “2 Wire” Entering 2 Wire Settings.

6.1 After connected to 2 Wire devices, set the corresponding wire length compensation and terminal resistor of the station. Power on the 2 Wire devices. Meanwhile the microphone of 2 Wire devices needs to be turned off or disconnected to make sure there's no other audio transmitting in the 2 Wire connection. Otherwise, the Auto Null will be affected. Select “Auto Null”, the station will complete the Auto Null operation of 2 Wire Devices;

6.2 Select “Cable Compen”, confirm the bus length of the same parallel 2 Wire Interface. Select the corresponding compensation selection according to the bus length;

6.3 Select “Terminal Res”, confirm whether the 2 Wire Device connected by the 2 Wire interface has terminal resistor. The terminal resistor needs to switch to Off if the 2 Wire Device has terminal resistor. The terminal resistor needs to switch to On if the 2 Wire Device doesn't have terminal resistor.

6.4 Select “Input Gain” to enter input gain adjust menu, Select the corresponding level to increase or decrease the corresponding value of the input signal;

6.5 Select “Output Gain” to enter output gain adjust menu, Select the corresponding level to increase or decrease the corresponding value of the output signal.

## ⑦ Select “Reset” to Reset all the Adjusted Info of Station to Defaults.

## ⑧ Select “Info” to Check the Information of the Station.

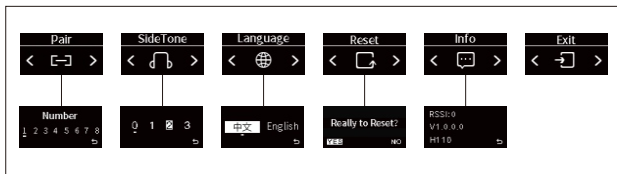

## BELPACK MENU INTRODUCTION

Long press Menu Key for 3 seconds to enter the menu, Following is the introduction of each function.

- ① **Connect the Beltpack to the Station by USB-A to TypeC Cable, Select “Pair”, the Beltpack can Paired with Station.**

Select the usable number from 1 to 8 to confirm pairing, Both the station and the beltpack's screens will display “Pairing...”. Disconnect the beltpack from station when the screens Display “Pairing Successful”.

- ② **Select “SideTone” to set the SideTone Output Volume.**

SideTone off when it is at Level 0, The SideTone will Increase from Level 1 to 3.

- ③ **Select “Language” to Switch Language to Chinese or English.**

- ④ **Select “Reset” to Reset all the Adjusted Info of Beltpack to Defaults.**

- ⑤ **Select “Info” to Check the Information of the Beltpack.**

- ⑥ **Select “Exit” Exit to the Main Menu.**

### ■ SET THE STATION BY WEB SERVER

Power on the station. Connect POE or PWR Interface to the Ethernet interface of computer by Ethernet Cable. Configure the network segment of the computer to be consistent with the station, Then open the browser on the computer and enter the following address (Check the corresponding address through the Network Menu of the station).

Master Device: 192.168.218.10

Slave Device: 192.168.218.11

Log in and enter Web page (Default passcode:12345678) can upgrade the Station, group the backpacks and adjust the status of backpacks.

### ■ SET THE STATION BY APP

Turn on the WiFi of station. Find the WiFi start with "HLD" on the phone and connect. Open the Solidcom App to connect. (Turn the WiFi on and check the corresponding Wifi name and password through the Network Menu of the station)

## PRODUCT INSTALLATION

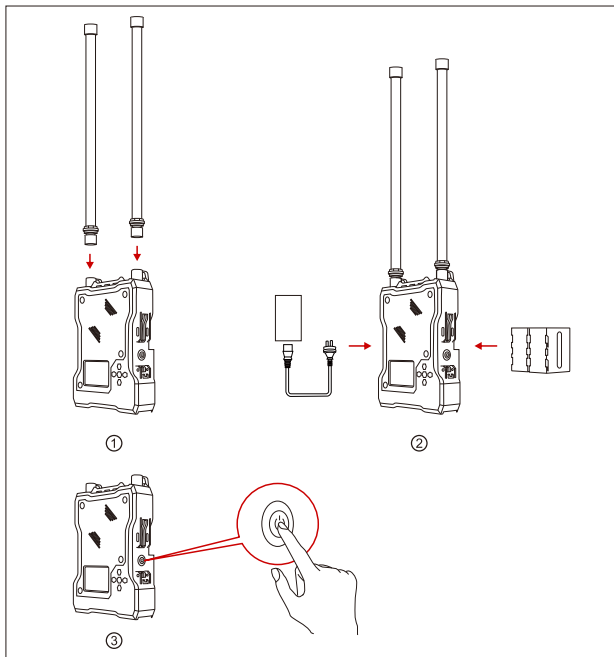

### ① Station Installation

1. Install the antenna according to the picture.
2. Connect the power adapter, or install NP-F type battery.
3. Press the power button to power on.

## PRODUCT INSTALLATION

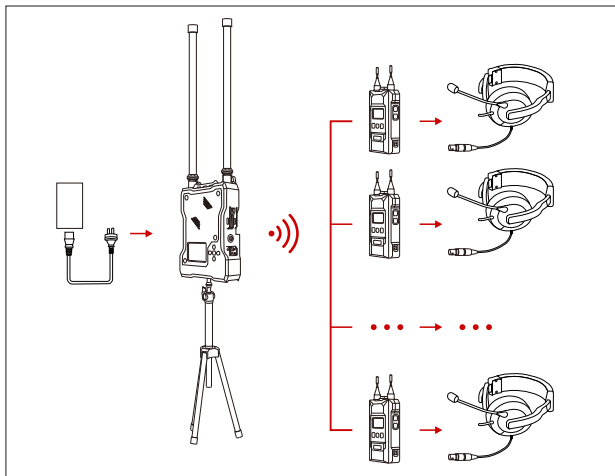

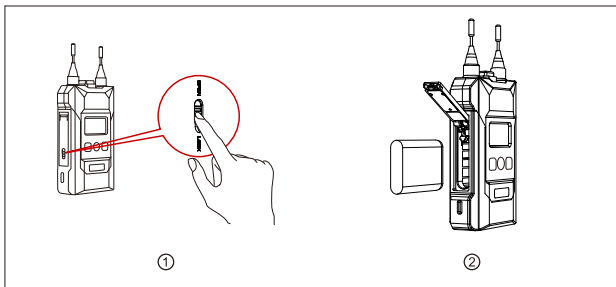

### ② Beltpack Installation

1. Open the battery compartment, insert the battery in the direction marked on the battery.
2. Switch the power switcher on to power on.
3. After the beltpack status changes from "LOST" to "TALK", You can Talk Now. Press the top button will change to "MUTE". The beltpack is able to listen but unable to talk. The status will be changed when the button is pressed again.
4. The beltpack supports both 3.5mm and LEMO headset to connect.
5. When connect to other Intercom Systems though 4 Wire or 2 Wire Audio Interfaces, Users can adjust input and output gain in the Menu of station to balance the entire gain of the Intercom System.
6. The battery will enter the dormant state after being placed for a period of time. It is recommended to fully charge and discharge the beltpack for the first three times.

### ③ Re-Pair

The beltpack number may be lost due to wrong operation or other reasons. You can connect the beltpack to the station with a USB to Type-C cable. Enters "Pair" Menu of the beltpack and select an optional number for pairing. Both the station and the beltpack's screens will display "Pairing...". Disconnect the beltpack from the station when the screens display "Pairing Successful".

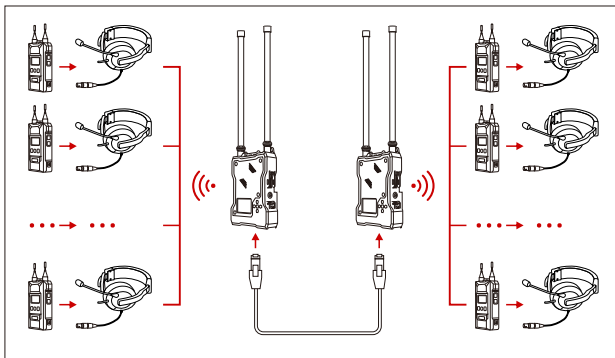

## ④ Cascade Two Sets of Devices

1. Through the dedicated-level Ethernet cable in the accessories, Two Sets of stations can be cascaded, and the number of belt packs can be expanded up to 16 Belt packs. When Cascading, One of the Master Device needs to be set as Slave Device. If set Master Device to Slave Device when used alone, the belt pack will not be able to talk and the device needs to be reset as Master Device.
2. When cascading, the belt pack number of the Slave Device will automatically change to 9-16.
3. When the Master Device uses the POE adapter to supply power, the POE adapter needs to connect to the Power Interface of the Master Station. When cascading, the Ethernet cable needs to connect to the POE Interface of the Master Device and the Power Interface of the Slave Device, which can realize the power supply to the Slave Device without Battery. It is available when the POE Adapter is not used but NP-F Type Battery for power supply.



## PARAMETERS

	Station	Beltpack
Interfaces	POE Interface (RJ45) Power Supply Interface (RJ45) 4 Wire Audio Interface USB Interface 2 Wire Audio Interface USB Type-C Interface	3.5mm Headset Interface LEMO Headset Interface USB-Type-C Interface
Power Supply	POE Power Supply NP-F Type Battery	1500mAh Lithium Polymer Battery
Frequency Response	200Hz to 7KHz	200Hz to 7KHz
Signal-to-Noise Ratio	>50dB	>50dB
Distortion	<1%	<1%
Use Range	450 Meters Line-of-Sight Usage	450 Meters Line-of-Sight Usage
Frequency Band	1.9GHz	1.9GHz
Modulation Mode	GFSK	GFSK
Transmit Power	Maximum 21dBm	Maximum 21dBm
Receiving Sensitivity	≤-93dBm	≤-93dBm
Frequency Bandwidth	1.728MHz	1.728MHz
Power Consumption	<3W	<0.6W
Dimension	(L*W*H): 236 *180.4*48.5mm	(L*W*H): 105*65*26 mm
Weight	About 1560g	About 200g
Working Temperature	0 ~ +45°C(Working Status) -20 ~ +60°C(Stock Status)	0 ~ +45°C(Working Status) -20 ~ +60°C(Stock Status)

## SAFETY PRECAUTIONS

Do not place the belt packs in the accessories or inside of Heating Equipment, Cooking equipment, High-Pressure Containers, etc. (Such as Microwave Ovens, Induction Cookers, Electric Ovens, Electric Heaters, Pressure Cookers, Water Heaters, Gas Stoves, etc.) to prevent the battery from overheating and exploding. The Charger, data cable and battery of the original matching model must be used. Using chargers, data Cables, and batteries that are not certified by the manufacturer or of non-matching models may cause Electric Shock, Fire, Explosion, or Other Dangers.

If encounter any problems in using the product or need any help, please follow these ways to get more technical support:

 Hollyland Products User Group

 HollylandTech

 HollylandTech

 support@hollyland-tech.com

 www.hollyland-tech.com

### FCC Caution:

Any Changes or modifications not expressly approved by the party responsible for compliance could void the user's authority to operate the equipment.

This device complies with part 15 of the FCC Rules. Operation is subject to the following two conditions: (1) This device may not cause harmful interference, and (2) this device must accept any interference received, including interference that may cause undesired operation.

### IMPORTANT NOTE:

Note: This equipment has been tested and found to comply with the limits for a Class B digital device, pursuant to part 15 of the FCC Rules. These limits are designed to provide reasonable protection against harmful interference in a residential installation. This equipment generates, uses and can radiate radio frequency energy and, if not installed and used in accordance with the instructions, may cause harmful interference to radio communications.

However, there is no guarantee that interference will not occur in a particular installation. If this equipment does cause harmful interference to radio or television reception, which can be determined by turning the equipment off and on, the user is encouraged to try to correct the interference by one or more of the following measures:

- Reorient or relocate the receiving antenna.
- Increase the separation between the equipment and receiver.
- Connect the equipment into an outlet on a circuit different from that to which the receiver is connected.
- Consult the dealer or an experienced radio/TV technician for help.

### FCC Radiation Exposure Statement:

#### For Station:

This equipment complies with FCC radiation exposure limits set forth for an uncontrolled environment. This equipment should be installed and operated with minimum distance 20cm between the radiator & your body.

#### For Beltpack:

The device has been tested and comply with FCC SAR limits.





 Hollyland Products User Group

 HollylandTech

 HollylandTech

 support@hollyland-tech.com

 www.hollyland-tech.com

**SHENZHEN HOLLYLAND TECHNOLOGY CO., LTD**

---

8F, 5D Building, Skyworth Innovation Valley, Tangtou, Shiyan, Baoan District Shenzhen, China.