

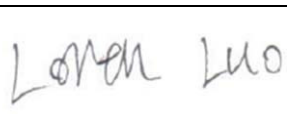

# RF TEST REPORT



Report No.: 17070226-FCC-R5

Supersede Report No.: N/A

Applicant	TECNO MOBILE LIMITED	
Product Name	Mobile phone	
Model No.	WX4 Pro	
Serial No.	N/A	
Test Standard	FCC Part 22(H):2016, FCC Part 24(E):2016, FCC Part 27: 2016; ANSI/TIA-603-D: 2010	
Test Date	March 28 to April 17, 2017	
Issue Date	April 17, 2017	
Test Result	<input checked="" type="checkbox"/> Pass <input type="checkbox"/> Fail	
Equipment complied with the specification	<input checked="" type="checkbox"/>	
Equipment did not comply with the specification	<input type="checkbox"/>	
		
Loren Luo Test Engineer	David Huang Checked By	
This test report may be reproduced in full only Test result presented in this test report is applicable to the tested sample only		

Issued by:

**SIEMIC (SHENZHEN-CHINA) LABORATORIES**

Zone A, Floor 1, Building 2 Wan Ye Long Technology Park

South Side of Zhoushi Road, Bao' an District, Shenzhen, Guangdong China 518108

Phone: +86 0755 2601 4629801 Email: [China@siemic.com.cn](mailto:China@siemic.com.cn)

## Laboratories Introduction

SIEMIC, headquartered in the heart of Silicon Valley, with superior facilities in US and Asia, is one of the leading independent testing and certification facilities providing customers with one-stop shop services for Compliance Testing and Global Certifications.



In addition to testing and certification, SIEMIC provides initial design reviews and compliance management throughout a project. Our extensive experience with China, Asia Pacific, North America, European, and International compliance requirements, assures the fastest, most cost effective way to attain regulatory compliance for the global markets.

### Accreditations for Conformity Assessment

Country/Region	Scope
USA	EMC, RF/Wireless, SAR, Telecom
Canada	EMC, RF/Wireless, SAR, Telecom
Taiwan	EMC, RF, Telecom, SAR, Safety
Hong Kong	RF/Wireless, SAR, Telecom
Australia	EMC, RF, Telecom, SAR, Safety
Korea	EMI, EMS, RF, SAR, Telecom, Safety
Japan	EMI, RF/Wireless, SAR, Telecom
Singapore	EMC, RF, SAR, Telecom
Europe	EMC, RF, SAR, Telecom, Safety

Test Report	17070226-FCC-R5
Page	3 of 112

This page has been left blank intentionally.

# CONTENTS

<b>1. REPORT REVISION HISTORY .....</b>	<b>5</b>
<b>2. CUSTOMER INFORMATION .....</b>	<b>5</b>
<b>3. TEST SITE INFORMATION.....</b>	<b>5</b>
<b>4. EQUIPMENT UNDER TEST (EUT) INFORMATION.....</b>	<b>6</b>
<b>5. TEST SUMMARY .....</b>	<b>9</b>
<b>6. MEASUREMENTS, EXAMINATION AND DERIVED RESULTS .....</b>	<b>10</b>
6.1 RF EXPOSURE (SAR).....	10
6.2 RF OUTPUT POWER.....	11
6.3 PEAK-AVERAGE RATIO.....	36
6.4 OCCUPIED BANDWIDTH.....	40
6.5 SPURIOUS EMISSIONS AT ANTENNA TERMINALS .....	62
6.6 SPURIOUS RADIATED EMISSIONS.....	66
6.7 BAND EDGE.....	71
6.8 BAND EDGE 27.53(M).....	84
6.9 FREQUENCY STABILITY .....	90
<b>ANNEX A. TEST INSTRUMENT.....</b>	<b>94</b>
<b>ANNEX B. EUT AND TEST SETUP PHOTOGRAPHS.....</b>	<b>96</b>
<b>ANNEX C. TEST SETUP AND SUPPORTING EQUIPMENT.....</b>	<b>108</b>
<b>ANNEX C.II. EUT OPERATING CONKITIONS.....</b>	<b>110</b>
<b>ANNEX D. USER MANUAL / BLOCK DIAGRAM / SCHEMATICS / PARTLIST.....</b>	<b>111</b>
<b>ANNEX E. DECLARATION OF SIMILARITY.....</b>	<b>112</b>



## 1. Report Revision History

Report No.	Report Version	Description	Issue Date
17070226-FCC-R5	NONE	Original	April 17, 2017

## 2. Customer information

Applicant Name	TECNO MOBILE LIMITED
Applicant Add	ROOMS 05-15, 13A/F., SOUTH TOWER, WORLD FINANCE CENTRE, HARBOUR CITY, 17 CANTON ROAD, TSIM SHA TSUI, KOWLOON, HONG KONG
Manufacturer	SHENZHEN TECNO TECHNOLOGY CO.,LTD.
Manufacturer Add	1-4th Floor,3rd Building,Pacific Industrial Park,No.2088,Shenyan Road,Yantian District,Shenzhen,Guangdong,China

## 3. Test site information

Lab performing tests	SIEMIC (Shenzhen-China) LABORATORIES
Lab Address	Zone A, Floor 1, Building 2 Wan Ye Long Technology Park South Side of Zhoushi Road, Bao' an District, Shenzhen, Guangdong China 518108
FCC Test Site No.	718246
IC Test Site No.	4842E-1
Test Software of Radiated Emission	Radiated Emission Program-To Shenzhen v2.0
Test Software of Conducted Emission	EZ-EMC(ver.lcp-03A1)

## 4. Equipment under Test (EUT) Information

Description of EUT:	Mobile phone
Main Model:	WX4 Pro
Serial Model:	N/A
Date EUT received:	March 27, 2017
Test Date(s):	March 28 to April 17, 2017
Equipment Category :	PCE
Antenna Gain:	GSM850: -0.2dBi PCS1900:1.7dBi UMTS-FDD Band V: -0.2dBi UMTS-FDD Band II:1.7dBi LTE Band II:1.7dBi LTE Band IV:1.7dBi LTE Band VII:2.5dBi WIFI:2.0dBi Bluetooth/BLE:2.0dBi GPS: 1.7dBi
Antenna Type:	PIFA antenna
Type of Modulation:	GSM / GPRS: GMSK EGPRS: GMSK,8PSK UMTS-FDD: QPSK LTE Band: QPSK, 16QAM 802.11b/g/n: DSSS, OFDM Bluetooth: GFSK, $\pi$ /4DQPSK, 8DPSK BLE: GFSK GPS:BPSK

	GSM850 TX: 824.2 ~ 848.8 MHz; RX: 869.2 ~ 893.8 MHz
	PCS1900 TX: 1850.2 ~ 1909.8 MHz; RX: 1930.2 ~ 1989.8 MHz
	UMTS-FDD Band V TX: 826.4 ~ 846.6 MHz; RX: 871.4 ~ 891.6 MHz
	UMTS-FDD Band II TX: 1852.4 ~ 1907.6 MHz;
	RX: 1932.4 ~ 1987.6 MHz
RF Operating Frequency (ies):	LTE Band II TX: 1850.7~ 1909.3 MHz; RX : 1930.7 ~ 1989.3 MHz
	LTE Band IV TX: 1710.7 ~ 1754.3 MHz; RX : 2110.7 ~ 2154.3 MHz
	LTE Band VII TX: 2502.5 ~ 2567.5 MHz; RX : 2622.5 ~ 2687.5 MHz
	WIFI: 802.11b/g/n(20M): 2412-2462 MHz
	WIFI: 802.11n(40M): 2422-2452 MHz
	Bluetooth& BLE: 2402-2480 MHz
	GPS: 1575.42 MHz
	GSM 850: 124CH
	PCS1900: 299CH
	UMTS-FDD Band V : 102CH
	UMTS-FDD Band II : 277CH
Number of Channels:	WIFI :802.11b/g/n(20M): 11CH
	WIFI :802.11n(40M): 7CH
	Bluetooth: 79CH
	BLE: 40CH
	GPS:1CH
Maximum Conducted	LTE band II: 23.15 dBm
AV Power to Antenna:	LTE band IV: 23.06 dBm
	LTE band VII: 23.32 dBm
ERP/EIRP:	LTE band II: 24.85 dBm / EIRP
	LTE band IV: 24.80 dBm / EIRP
	LTE band VII: 25.82 dBm / EIRP
Port:	USB Port, Earphone Port

Input Power: Adapter:  
Model:A8-501000  
Input: AC100-240V~50/60Hz,200mA  
Output: DC 5.0V,1.0A  
Battery:  
Model:BL-28BT  
Spec:3.85V,10.78Wh,2800mAh  
Limited charge voltage:4.4V

Trade Name : TECNO

GPRS/EGPRS Multi-slot class 8/10/12

FCC ID: 2ADYY-WX4PRO

## 5. Test Summary

The product was tested in accordance with the following specifications.

All testing has been performed according to below product classification:

FCC Rules	Description of Test	Result
§ 1.1307; § 2.1093	RF Exposure (SAR)	Compliance
§2.1046; § 22.913(a); § 24.232(c); § 27.50(c.10); § 27.50(d.4)	RF Output Power	Compliance
§ 24.232 (d); § 27.50(d)	Peak-Average Ratio	Compliance
§ 2.1049; § 22.905; § 22.917; § 24.238; § 27.53(a.5)	99% & -26 dB Occupied Bandwidth	Compliance
§ 2.1051; § 22.917(a); § 24.238(a); § 27.53(h)	Spurious Emissions at Antenna Terminal	Compliance
§ 2.1053; § 22.917(a); § 24.238(a); § 27.53(h)	Field Strength of Spurious Radiation	Compliance
§ 22.917(a); § 24.238(a);	Out of band emission, Band Edge	Compliance
§ 27.53(m)	Band Edge 27.53(m)	Compliance
§ 2.1055; § 22.355; § 24.235; § 27.5(h); § 27.54	Frequency stability vs. temperature Frequency stability vs. voltage	Compliance

Note: Testing was performed by configuring EUT to maximum output power status, the declared output power class for different

### Measurement Uncertainty

Emissions		
Test Item	Description	Uncertainty
Band Edge and Radiated Spurious Emissions	Confidence level of approximately 95% (in the case where distributions are normal), with a coverage factor of 2 (for EUTs < 0.5m X 0.5m X 0.5m)	+5.6dB/-4.5dB
-	-	-

## 6. MEASUREMENTS, EXAMINATION AND DERIVED RESULTS

### 6.1 RF Exposure (SAR)

Test Result: Pass

The EUT is a portable device, thus requires SAR evaluation;

Please refer to RF Exposure Evaluation Report: 17070226-FCC-H.

## 6.2 RF Output Power

Temperature	22°C
Relative Humidity	53%
Atmospheric Pressure	1010mbar
Test date :	April 13, 2017
Tested By :	Loren Luo

### Requirement(s):

Spec	Item	Requirement	Applicable
§22.913 (a)	a)	ERP:38.45dBm	<input checked="" type="checkbox"/>
§24.232 (c)	b)	EIRP:33dBm	<input checked="" type="checkbox"/>
§27.50 (c)	c)	EIRP: 30dBm	<input checked="" type="checkbox"/>

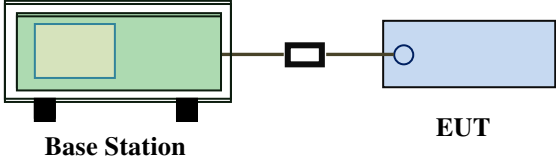
Test Setup	 <p style="text-align: center;">Base Station                      EUT</p>
------------	--

Test Procedure	<p>For Conducted Power:</p> <ul style="list-style-type: none"> <li>- The transmitter output port was connected to base station.</li> <li>- Set EUT at maximum power through base station.</li> <li>- Select lowest, middle, and highest channels for each band and different test mode.</li> </ul> <p>For ERP/EIRP:</p> <ul style="list-style-type: none"> <li>- The transmitter was placed on a wooden turntable, and it was transmitting into a non-radiating load which was also placed on the turntable.</li> <li>- The measurement antenna was placed at a distance of 3 meters from the EUT. During the tests, the antenna height and polarization as well as EUT azimuth were varied in order to identify the maximum level of emissions from the EUT. The test was performed by placing the EUT on 3-orthogonal axis.</li> <li>- The frequency range up to tenth harmonic of the fundamental frequency was investigated.</li> </ul>
----------------	---

	<ul style="list-style-type: none"> <li>- Remove the EUT and replace it with substitution antenna. A signal generator was connected to the substitution antenna by a non-radiating cable. The absolute levels of the spurious emissions were measured by the substitution.</li> <li>- Spurious emissions in dB = 10 log (TX power in Watts/0.001) – the absolute level</li> <li>- Spurious attenuation limit in dB = 43 + 10 Log10 (power out in Watts).</li> </ul>
Remark	
Result	<input checked="" type="checkbox"/> Pass <input type="checkbox"/> Fail

Test Data     Yes                       N/A  
 Test Plot     Yes (See below)             N/A



### Conducted Power

#### LTE Band II:

BW (MHz)	Ch	Freq. (MHz)	Mode	UL RB Allocation	UL RB Offset	MPR	Average power (dBm)	Tune up Power tolerant
20MHz	18700	1860.0	QPSK	1	0	0	22.98	22 ± 1
				1	49	0	22.99	22 ± 1
				1	99	0	22.95	22 ± 1
				50	0	1	21.92	22 ± 1
				50	24	1	21.93	22 ± 1
				50	49	1	21.89	22 ± 1
			100	0	1	21.91	22 ± 1	
			16QAM	1	0	1	21.9	21.5 ± 1
				1	49	1	21.89	21.5 ± 1
				1	99	1	21.87	21.5 ± 1
				50	0	2	21.93	21.5 ± 1
				50	24	2	21.92	21.5 ± 1
				50	49	2	21.9	21.5 ± 1
				100	0	2	20.93	21.5 ± 1
	18900	1880.0		QPSK	1	0	0	22.91
			1		49	0	22.93	22.5 ± 1
			1		99	0	22.95	22.5 ± 1
			50		0	1	22.03	22.5 ± 1
			50		24	1	22.03	22.5 ± 1
			50		49	1	22.01	22.5 ± 1
			100	0	1	21.96	22.5 ± 1	
			16QAM	1	0	1	22.15	21.3 ± 1
				1	49	1	22.14	21.3 ± 1
				1	99	1	22.18	21.3 ± 1
	50	0		2	21.96	21.3 ± 1		
	50	24	2	21.97	21.3 ± 1			
	50	49	2	21.93	21.3 ± 1			
100	0	2	20.99	21.3 ± 1				
19100	1900.0	QPSK	1	0	0	23.14	22.5 ± 1	
			1	49	0	<b>23.15</b>	22.5 ± 1	
			1	99	0	23.11	22.5 ± 1	
			50	0	1	22.03	22.5 ± 1	
			50	24	1	22.05	22.5 ± 1	
			50	49	1	22.06	22.5 ± 1	
			100	0	1	22.02	22.5 ± 1	
		16QAM	1	0	1	22.46	22 ± 1	
			1	49	1	22.45	22 ± 1	
			1	99	1	22.41	22 ± 1	
			50	0	2	22.05	22 ± 1	
			50	24	2	22.04	22 ± 1	
			50	49	2	22.03	22 ± 1	
100	0	2	21.02	22 ± 1				

BW (MHz)	Ch	Freq. (MHz)	Mode	UL RB Allocation	UL RB Offset	MPR	Average power (dBm)	Tune up Power tolerant
15MHz	18675	1857.5	QPSK	1	0	0	22.99	22 ± 1
				1	37	0	22.96	22 ± 1
				1	74	0	22.93	22 ± 1
				36	0	1	21.93	22 ± 1
				36	16	1	21.93	22 ± 1
				36	35	1	21.95	22 ± 1
				75	0	1	21.9	22 ± 1
			16QAM	1	0	1	21.77	21.3 ± 1
				1	37	1	21.75	21.3 ± 1
				1	74	1	21.74	21.3 ± 1
				36	0	2	21.93	21.3 ± 1
				36	16	2	21.95	21.3 ± 1
				36	35	2	21.92	21.3 ± 1
				75	0	2	20.95	21.3 ± 1
	18900	1880.0	QPSK	1	0	0	22.99	22.5 ± 1
				1	37	0	22.99	22.5 ± 1
				1	74	0	22.95	22.5 ± 1
				36	0	1	22.01	22.5 ± 1
				36	16	1	22.03	22.5 ± 1
				36	35	1	22.04	22.5 ± 1
				75	0	1	21.98	22.5 ± 1
			16QAM	1	0	1	22.19	21.3 ± 1
				1	37	1	22.15	21.3 ± 1
				1	74	1	22.17	21.3 ± 1
				36	0	2	22.02	21.3 ± 1
				36	16	2	22.03	21.3 ± 1
				36	35	2	22.04	21.3 ± 1
				75	0	2	20.97	21.3 ± 1
	19125	1902.5	QPSK	1	0	0	22.97	22.5 ± 1
				1	37	0	22.96	22.5 ± 1
1				74	0	22.99	22.5 ± 1	
36				0	1	21.99	22.5 ± 1	
36				16	1	21.95	22.5 ± 1	
36				35	1	21.99	22.5 ± 1	
75				0	1	21.96	22.5 ± 1	
16QAM			1	0	1	22.57	22.5 ± 1	
			1	37	1	22.56	22.5 ± 1	
			1	74	1	22.54	22.5 ± 1	
			36	0	2	21.96	22.5 ± 1	
			36	16	2	21.93	22.5 ± 1	
			36	35	2	21.94	22.5 ± 1	
			75	0	2	22.99	22.5 ± 1	

BW (MHz)	Ch	Freq. (MHz)	Mode	UL RB Allocation	UL RB Offset	MPR	Average power (dBm)	Tune up Power tolerant
10MHz	18650	1855	QPSK	1	0	0	22.96	22.5 ± 1
				1	24	0	22.95	22.5 ± 1
				1	49	0	22.94	22.5 ± 1
				25	0	1	21.84	22.5 ± 1
				25	12	1	21.85	22.5 ± 1
				25	24	1	21.83	22.5 ± 1
				50	0	1	21.87	22.5 ± 1
			16QAM	1	0	1	21.73	21.3 ± 1
				1	24	1	21.75	21.3 ± 1
				1	49	1	21.74	21.3 ± 1
				25	0	2	21.84	21.3 ± 1
				25	12	2	21.85	21.3 ± 1
				25	24	2	21.88	21.3 ± 1
				50	0	2	20.91	21.3 ± 1
	18900	1880.0	QPSK	1	0	0	22.99	22.5 ± 1
				1	24	0	22.92	22.5 ± 1
				1	49	0	22.92	22.5 ± 1
				25	0	1	21.89	22.5 ± 1
				25	12	1	21.88	22.5 ± 1
				25	24	1	21.86	22.5 ± 1
				50	0	1	21.93	22.5 ± 1
			16QAM	1	0	1	21.82	21.3 ± 1
				1	24	1	21.86	21.3 ± 1
				1	49	1	21.85	21.3 ± 1
				25	0	2	20.76	21.3 ± 1
				25	12	2	20.74	21.3 ± 1
				25	24	2	20.73	21.3 ± 1
				50	0	2	20.98	21.3 ± 1
	19150	1905	QPSK	1	0	0	22.94	22.5 ± 1
				1	24	0	22.95	22.5 ± 1
1				49	0	22.96	22.5 ± 1	
25				0	1	21.95	22.5 ± 1	
25				12	1	21.95	22.5 ± 1	
25				24	1	21.94	22.5 ± 1	
50				0	1	21.94	22 ± 1	
16QAM			1	0	1	22.52	22 ± 1	
			1	24	1	22.54	22 ± 1	
			1	49	1	22.53	22 ± 1	
			25	0	2	21.95	22 ± 1	
			25	12	2	21.99	22 ± 1	
			25	24	2	21.93	22 ± 1	
			50	0	2	21.00	22 ± 1	

BW (MHz)	Ch	Freq. (MHz)	Mode	UL RB Allocation	UL RB Offset	MPR	Average power (dBm)	Tune up Power tolerant
5MHz	18625	1852.5	QPSK	1	0	0	22.96	22 ± 1
				1	12	0	22.94	22 ± 1
				1	24	0	22.98	22 ± 1
				12	0	1	21.91	22 ± 1
				12	6	1	21.91	22 ± 1
				12	11	1	21.91	22 ± 1
				25	0	1	21.85	22 ± 1
			16QAM	1	0	1	22.00	21.3 ± 1
				1	12	1	22.02	21.3 ± 1
				1	24	1	22.05	21.3 ± 1
				12	0	2	21.91	21.3 ± 1
				12	6	2	21.92	21.3 ± 1
				12	11	2	21.94	21.3 ± 1
				25	0	2	21.01	21.3 ± 1
	18900	1880.0	QPSK	1	0	0	22.99	22.3 ± 1
				1	12	0	22.96	22.3 ± 1
				1	24	0	22.98	22.3 ± 1
				12	0	1	22.02	22.3 ± 1
				12	6	1	22.04	22.3 ± 1
				12	11	1	22.03	22.3 ± 1
				25	0	1	21.94	22.3 ± 1
			16QAM	1	0	1	22.3	22.3 ± 1
				1	12	1	22.35	22.3 ± 1
				1	24	1	22.35	22.3 ± 1
				12	0	2	22.02	22.3 ± 1
				12	6	2	22.03	22.3 ± 1
				12	11	2	22.04	22.3 ± 1
				25	0	2	21.00	22.3 ± 1
	19175	1907.5	QPSK	1	0	0	22.98	22.5 ± 1
				1	12	0	22.95	22.5 ± 1
1				24	0	22.94	22.5 ± 1	
12				0	1	21.98	22.5 ± 1	
12				6	1	21.95	22.5 ± 1	
12				11	1	21.96	22.5 ± 1	
25				0	1	21.93	22.5 ± 1	
16QAM			1	0	1	21.91	21.5 ± 1	
			1	12	1	21.92	21.5 ± 1	
			1	24	1	21.95	21.5 ± 1	
			12	0	2	21.98	21.5 ± 1	
			12	6	2	21.96	21.5 ± 1	
			12	11	2	21.95	21.5 ± 1	
			25	0	2	21.06	21.5 ± 1	

BW (MHz)	Ch	Freq. (MHz)	Mode	UL RB Allocation	UL RB Offset	MPR	Average power (dBm)	Tune up Power tolerant
3MHz	18625	1852.5	QPSK	1	0	0	22.9	22.3±1
				1	7	0	22.95	22.3±1
				1	14	0	22.94	22.3±1
				8	0	1	21.80	22.3±1
				8	4	1	21.86	22.3±1
				8	7	1	21.84	22.3±1
				15	0	1	21.83	22.3±1
			16QAM	1	0	1	21.67	21±1
				1	7	1	21.65	21±1
				1	14	1	21.69	21±1
				8	0	2	20.82	21±1
				8	4	2	20.86	21±1
				8	7	2	20.84	21±1
				15	0	2	20.81	21±1
	18900	1880.0	QPSK	1	0	0	22.98	22.5±1
				1	7	0	22.95	22.5±1
				1	14	0	22.94	22.5±1
				8	0	1	21.89	22.5±1
				8	4	1	21.84	22.5±1
				8	7	1	21.85	22.5±1
				15	0	1	21.93	22.5±1
			16QAM	1	0	1	21.82	21.3±1
				1	7	1	21.85	21.3±1
				1	14	1	21.84	21.3±1
				8	0	2	20.76	21.3±1
				8	4	2	20.74	21.3±1
				8	7	2	20.75	21.3±1
				15	0	2	20.98	21.3±1
	19175	1907.5	QPSK	1	0	0	22.82	22.5±1
				1	7	0	22.85	22.5±1
1				14	0	22.84	22.5±1	
8				0	1	21.89	22.5±1	
8				4	1	21.85	22.5±1	
8				7	1	21.85	22.5±1	
15				0	1	21.90	22.5±1	
16QAM			1	0	1	22.38	22.5±1	
			1	7	1	22.36	22.5±1	
			1	14	1	22.34	22.5±1	
			8	0	2	20.89	22.5±1	
			8	4	2	20.88	22.5±1	
			8	7	2	20.86	22.5±1	
			15	0	2	21.02	22.5±1	

BW (MHz)	Ch	Freq. (MHz)	Mode	UL RB Allocation	UL RB Offset	MPR	Average power (dBm)	Tune up Power tolerant
1.4MHz	18607	1850.7	QPSK	1	0	0	22.91	22.5±1
				1	2	0	22.92	22.5±1
				1	5	0	22.95	22.5±1
				3	0	0	22.98	22.5±1
				3	1	0	22.98	22.5±1
				3	2	0	22.94	22.5±1
			6	0	1	21.8	22.5±1	
			16QAM	1	0	1	21.66	22.5±1
				1	2	1	21.69	22.5±1
				1	5	1	21.66	22.5±1
				3	0	1	22.99	22.5±1
				3	1	1	22.98	22.5±1
	3	2		1	22.94	22.5±1		
	6	0	2	20.8	22.5±1			
	18900	1880.0	QPSK	1	0	0	22.99	22.3±1
				1	2	0	22.94	22.3±1
				1	5	0	22.99	22.3±1
				3	0	0	22.95	22.3±1
				3	1	0	22.94	22.3±1
				3	2	0	22.91	22.3±1
			6	0	1	21.9	22.3±1	
			16QAM	1	0	1	21.9	21.3±1
				1	2	1	21.95	21.3±1
				1	5	1	21.94	21.3±1
				3	0	1	22.96	21.3±1
				3	1	1	22.93	21.3±1
	3	2		1	22.94	21.3±1		
	6	0	2	20.78	21.3±1			
	19193	1909.3	QPSK	1	0	0	22.85	22.3±1
				1	2	0	22.86	22.3±1
1				5	0	22.87	22.3±1	
3				0	0	22.95	22.3±1	
3				1	0	22.98	22.3±1	
3				2	0	22.97	22.3±1	
6			0	1	21.85	22.3±1		
16QAM			1	0	1	21.46	22.3±1	
			1	2	1	21.48	22.3±1	
			1	5	1	21.49	22.3±1	
			3	0	1	22.99	22.3±1	
			3	1	1	22.95	22.3±1	
	3	2	1	22.97	22.3±1			
6	0	2	21.01	22.3±1				

**LTE band IV:**

BW (MHz)	Ch	Freq. (MHz)	Mode	UL RB Allocation	UL RB Offset	MPR	Average power (dBm)	Tune up Power tolerant
20MHz	20050	1720.0	QPSK	1	0	0	<b>22.99</b>	22.5±1
				1	49	0	22.95	22.5±1
				1	99	0	22.94	22.5±1
				50	0	1	21.95	22.5±1
				50	24	1	21.95	22.5±1
				50	49	1	21.94	22.5±1
				100	0	1	21.94	22.5±1
			16QAM	1	0	1	21.95	21.5±1
				1	49	1	21.96	21.5±1
				1	99	1	21.97	21.5±1
				50	0	2	21.95	21.5±1
				50	24	2	21.94	21.5±1
				50	49	2	21.96	21.5±1
				100	0	2	20.97	21.5±1
	20175	1732.5	QPSK	1	0	0	22.95	22.5±1
				1	49	0	22.94	22.5±1
				1	99	0	22.92	22.5±1
				50	0	1	22.03	22.5±1
				50	24	1	22.02	22.5±1
				50	49	1	22.01	22.5±1
				100	0	1	21.99	22.5±1
			16QAM	1	0	1	22.17	22±1
				1	49	1	22.14	22±1
				1	99	1	22.16	22±1
				50	0	2	22.01	22±1
				50	24	2	22.03	22±1
				50	49	2	22.04	22±1
				100	0	2	21.01	22±1
	20300	1745.0	QPSK	1	0	0	22.99	22±1
				1	49	0	22.95	22±1
1				99	0	22.97	22±1	
50				0	1	21.95	22±1	
50				24	1	21.96	22±1	
50				49	1	21.94	22±1	
100				0	1	21.94	22±1	
16QAM			1	0	1	22.37	22±1	
			1	49	1	22.35	22±1	
			1	99	1	22.39	22±1	
			50	0	2	21.95	22±1	
			50	24	2	21.96	22±1	
			50	49	2	21.94	22±1	
			100	0	2	21.02	22±1	

BW (MHz)	Ch	Freq. (MHz)	Mode	UL RB Allocation	UL RB Offset	MPR	Average power (dBm)	Tune up Power tolerant
15MHz	20025	1717.5	QPSK	1	0	0	22.93	22 ± 1
				1	37	0	22.94	22 ± 1
				1	74	0	22.95	22 ± 1
				36	0	1	21.95	22 ± 1
				36	16	1	21.96	22 ± 1
				36	35	1	21.94	22 ± 1
				75	0	1	21.96	22 ± 1
			16QAM	1	0	1	21.78	22 ± 1
				1	37	1	21.74	22 ± 1
				1	74	1	21.79	22 ± 1
				36	0	2	21.95	22 ± 1
				36	16	2	21.96	22 ± 1
				36	35	2	21.93	22 ± 1
				75	0	2	21.01	22 ± 1
	20175	1732.5	QPSK	1	0	0	22.99	22 ± 1
				1	37	0	22.95	22 ± 1
				1	74	0	22.97	22 ± 1
				36	0	1	22.06	22 ± 1
				36	16	1	22.06	22 ± 1
				36	35	1	22.04	22 ± 1
				75	0	1	22.03	22 ± 1
			16QAM	1	0	1	22.19	22 ± 1
				1	37	1	22.21	22 ± 1
				1	74	1	22.23	22 ± 1
				36	0	2	22.06	22 ± 1
				36	16	2	22.05	22 ± 1
				36	35	2	22.08	22 ± 1
				75	0	2	21.01	22 ± 1
	20325	1747.5	QPSK	1	0	0	22.94	22 ± 1
				1	37	0	22.95	22 ± 1
1				74	0	22.96	22 ± 1	
36				0	1	21.97	22 ± 1	
36				16	1	21.96	22 ± 1	
36				35	1	21.93	22 ± 1	
75				0	1	21.95	22 ± 1	
16QAM			1	0	1	22.46	22 ± 1	
			1	37	1	22.45	22 ± 1	
			1	74	1	22.48	22 ± 1	
			36	0	2	21.97	22 ± 1	
			36	16	2	21.95	22 ± 1	
			36	35	2	21.98	22 ± 1	
			75	0	2	21.02	22 ± 1	



BW (MHz)	Ch	Freq. (MHz)	Mode	UL RB Allocation	UL RB Offset	MPR	Average power (dBm)	Tune up Power tolerant
10MHz	20000	1715.0	QPSK	1	0	0	22.94	22 ± 1
				1	24	0	22.95	22 ± 1
				1	49	0	22.96	22 ± 1
				25	0	1	21.88	22 ± 1
				25	12	1	21.86	22 ± 1
				25	24	1	21.85	22 ± 1
				50	0	1	21.91	22 ± 1
			16QAM	1	0	1	21.76	21.5 ± 1
				1	24	1	21.75	21.5 ± 1
				1	49	1	21.74	21.5 ± 1
				25	0	2	21.86	21.5 ± 1
				25	12	2	21.85	21.5 ± 1
				25	24	2	21.85	21.5 ± 1
				50	0	2	20.94	21.5 ± 1
	20175	1732.5	QPSK	1	0	0	22.97	22 ± 1
				1	24	0	22.95	22 ± 1
				1	49	0	22.98	22 ± 1
				25	0	1	21.98	22 ± 1
				25	12	1	21.95	22 ± 1
				25	24	1	21.96	22 ± 1
				50	0	1	21.98	22 ± 1
			16QAM	1	0	1	21.94	22 ± 1
				1	24	1	21.95	22 ± 1
				1	49	1	21.96	22 ± 1
				25	0	2	21.98	22 ± 1
				25	12	2	21.95	22 ± 1
				25	24	2	21.96	22 ± 1
				50	0	2	21.01	22 ± 1
	20350	1750.0	QPSK	1	0	0	22.87	22 ± 1
				1	24	0	22.86	22 ± 1
1				49	0	22.88	22 ± 1	
25				0	1	21.9	22 ± 1	
25				12	1	21.92	22 ± 1	
25				24	1	21.91	22 ± 1	
50				0	1	21.9	22 ± 1	
16QAM			1	0	1	22.42	22 ± 1	
			1	24	1	22.43	22 ± 1	
			1	49	1	22.41	22 ± 1	
			25	0	2	21.9	22 ± 1	
			25	12	2	21.92	22 ± 1	
			25	24	2	21.93	22 ± 1	
			50	0	2	21.01	22 ± 1	

BW (MHz)	Ch	Freq. (MHz)	Mode	UL RB Allocation	UL RB Offset	MPR	Average power (dBm)	Tune up Power tolerant
5MHz	20000	1715.0	QPSK	1	0	0	22.99	22 ± 1
				1	12	0	22.95	22 ± 1
				1	24	0	22.94	22 ± 1
				12	0	1	21.97	22 ± 1
				12	6	1	21.96	22 ± 1
				12	11	1	21.95	22 ± 1
				25	0	1	21.91	22 ± 1
			16QAM	1	0	1	22.01	22 ± 1
				1	12	1	22.03	22 ± 1
				1	24	1	22.02	22 ± 1
				12	0	2	21.96	22 ± 1
				12	6	2	21.04	22 ± 1
				12	11	2	21.02	22 ± 1
				25	0	2	21.02	22 ± 1
	20175	1732.5	QPSK	1	0	0	22.99	22 ± 1
				1	12	0	22.95	22 ± 1
				1	24	0	22.96	22 ± 1
				12	0	1	22.03	22 ± 1
				12	6	1	22.05	22 ± 1
				12	11	1	22.04	22 ± 1
				25	0	1	21.97	22 ± 1
			16QAM	1	0	1	22.24	22 ± 1
				1	12	1	22.25	22 ± 1
				1	24	1	22.26	22 ± 1
				12	0	2	21.97	22 ± 1
				12	6	2	21.96	22 ± 1
				12	11	2	21.95	22 ± 1
				25	0	2	21.02	22 ± 1
	20350	1750.0	QPSK	1	0	0	22.99	22 ± 1
				1	12	0	22.96	22 ± 1
1				24	0	22.98	22 ± 1	
12				0	1	21.97	22 ± 1	
12				6	1	21.96	22 ± 1	
12				11	1	21.97	22 ± 1	
25				0	1	21.88	22 ± 1	
16QAM			1	0	1	21.89	22 ± 1	
			1	12	1	21.88	22 ± 1	
			1	24	1	21.87	22 ± 1	
			12	0	2	21.97	22 ± 1	
			12	6	2	21.96	22 ± 1	
			12	11	2	21.95	22 ± 1	
			25	0	2	22.99	22 ± 1	

BW (MHz)	Ch	Freq. (MHz)	Mode	UL RB Allocation	UL RB Offset	MPR	Average power (dBm)	Tune up Power tolerant
3MHz	19965	1711.5	QPSK	1	0	0	22.84	22 ± 1
				1	7	0	22.86	22 ± 1
				1	14	0	22.85	22 ± 1
				8	0	1	21.83	22 ± 1
				8	4	1	21.85	22 ± 1
				8	7	1	21.84	22 ± 1
				15	0	1	21.85	22 ± 1
			16QAM	1	0	1	21.71	21.5 ± 1
				1	7	1	21.7	21.5 ± 1
				1	14	1	21.73	21.5 ± 1
				8	0	2	20.82	21.5 ± 1
				8	4	2	20.82	21.5 ± 1
				8	7	2	20.83	21.5 ± 1
				15	0	2	20.84	21.5 ± 1
	20175	1732.5	QPSK	1	0	0	22.99	22 ± 1
				1	7	0	22.95	22 ± 1
				1	14	0	22.97	22 ± 1
				8	0	1	21.94	22 ± 1
				8	4	1	21.95	22 ± 1
				8	7	1	21.93	22 ± 1
				15	0	1	21.96	22 ± 1
			16QAM	1	0	1	21.9	21.5 ± 1
				1	7	1	21.92	21.5 ± 1
				1	14	1	21.95	21.5 ± 1
				8	0	2	20.79	21.5 ± 1
				8	4	2	20.78	21.5 ± 1
				8	7	2	20.77	21.5 ± 1
				15	0	2	21	21.5 ± 1
	20385	1753.5	QPSK	1	0	0	22.79	22 ± 1
				1	7	0	22.78	22 ± 1
				1	14	0	22.77	22 ± 1
				8	0	1	21.84	22 ± 1
				8	4	1	21.85	22 ± 1
				8	7	1	21.86	22 ± 1
				15	0	1	21.88	22 ± 1
			16QAM	1	0	1	22.37	22 ± 1
1				7	1	22.36	22 ± 1	
1				14	1	22.35	22 ± 1	
8				0	2	20.85	22 ± 1	
8				4	2	20.85	22 ± 1	
8				7	2	20.83	22 ± 1	
15				0	2	20.99	22 ± 1	

BW (MHz)	Ch	Freq. (MHz)	Mode	UL RB Allocation	UL RB Offset	MPR	Average power (dBm)	Tune up Power tolerant
1.4MHz	19957	1710.7	QPSK	1	0	0	22.86	22 ± 1
				1	2	0	22.85	22 ± 1
				1	5	0	22.84	22 ± 1
				3	0	0	22.91	22 ± 1
				3	1	0	22.92	22 ± 1
				3	2	0	22.94	22 ± 1
			6	0	1	21.83	22 ± 1	
			16QAM	1	0	1	21.71	22 ± 1
				1	2	1	21.72	22 ± 1
				1	5	1	21.73	22 ± 1
				3	0	1	22.92	22 ± 1
				3	1	1	22.93	22 ± 1
				3	2	1	22.91	22 ± 1
				6	0	2	21.03	22 ± 1
	20175	QPSK		1732.5	1	0	0	23.05
			1		2	0	23.01	23 ± 1
			1		5	0	23.1	23 ± 1
			3		0	0	<b>23.06</b>	23 ± 1
			3		1	0	23.05	23 ± 1
			3		2	0	23.06	23 ± 1
			6		0	1	22.02	23 ± 1
		16QAM	1	0	1	21.87	21.3 ± 1	
			1	2	1	21.85	21.3 ± 1	
			1	5	1	21.86	21.3 ± 1	
			3	0	1	21.95	21.3 ± 1	
			3	1	1	21.96	21.3 ± 1	
			3	2	1	21.94	21.3 ± 1	
			6	0	2	20.8	21.3 ± 1	
20393	QPSK	1754.3	1	0	0	22.84	22 ± 1	
			1	2	0	22.85	22 ± 1	
			1	5	0	22.84	22 ± 1	
			3	0	0	22.98	22 ± 1	
			3	1	0	22.98	22 ± 1	
			3	2	0	22.94	22 ± 1	
			6	0	1	21.84	22 ± 1	
	16QAM	1	0	1	21.44	22 ± 1		
		1	2	1	21.45	22 ± 1		
		1	5	1	21.46	22 ± 1		
		3	0	1	22.98	22 ± 1		
		3	1	1	22.95	22 ± 1		
		3	2	1	22.94	22 ± 1		
		6	0	2	21.01	22 ± 1		

**LTE band VII:**

BW (MHz)	Ch	Freq. (MHz)	Mode	UL RB Allocation	UL RB Offset	MPR	Average power (dBm)	Tune up Power tolerant
20MHz	20850	2510	QPSK	1	0	0	<b>23.27</b>	23±1
				1	49	0	23.26	23±1
				1	99	0	23.24	23±1
				50	0	1	22.19	23±1
				50	24	1	22.18	23±1
				50	49	1	22.20	23±1
				100	0	1	22.15	23±1
			16QAM	1	0	1	22.17	22±1
				1	49	1	22.16	22±1
				1	99	1	22.15	22±1
				50	0	2	22.18	22±1
				50	24	2	21.04	22±1
				50	49	2	21.05	22±1
				100	0	2	21.06	22±1
	21100	2535	QPSK	1	0	0	23.02	22.1±1
				1	49	0	23.01	22.1±1
				1	99	0	23.01	22.1±1
				50	0	1	22.17	22.1±1
				50	24	1	22.16	22.1±1
				50	49	1	22.15	22.1±1
				100	0	1	21.24	22.1±1
			16QAM	1	0	1	22.34	22±1
				1	49	1	22.35	22±1
				1	99	1	22.31	22±1
				50	0	2	22.17	22±1
				50	24	2	22.15	22±1
				50	49	2	22.16	22±1
				100	0	2	21.05	22±1
	21350	2560	QPSK	1	0	0	23.04	22.1±1
				1	49	0	23.05	22.1±1
1				99	0	23.06	22.1±1	
50				0	1	23.04	22.1±1	
50				24	1	22.08	22.1±1	
50				49	1	22.06	22.1±1	
100				0	1	22.07	22.1±1	
16QAM			1	0	1	22.4	22±1	
			1	49	1	22.41	22±1	
			1	99	1	22.42	22±1	
			50	0	2	22.08	22±1	
			50	24	2	22.06	22±1	
			50	49	2	22.04	22±1	
			100	0	2	21.00	22±1	

BW (MHz)	Ch	Freq. (MHz)	Mode	UL RB Allocation	UL RB Offset	MPR	Average power (dBm)	Tune up Power tolerant
15MHz	20825	1717.5	QPSK	1	0	0	23.24	22.3±1
				1	37	0	23.25	22.3±1
				1	74	0	23.22	22.3±1
				36	0	1	22.29	22.3±1
				36	16	1	22.28	22.3±1
				36	35	1	22.27	22.3±1
				75	0	1	22.29	22.3±1
			16QAM	1	0	1	22.02	22±1
				1	37	1	22.03	22±1
				1	74	1	22.01	22±1
				36	0	2	22.29	22±1
				36	16	2	22.26	22±1
				36	35	2	22.27	22±1
				75	0	2	22.29	22±1
	21100	1732.5	QPSK	1	0	0	23.01	22.5±1
				1	37	0	23.02	22.5±1
				1	74	0	23.02	22.5±1
				36	0	1	22.13	22.5±1
				36	16	1	22.15	22.5±1
				36	35	1	22.14	22.5±1
				75	0	1	22.13	22.5±1
			16QAM	1	0	1	22.32	22±1
				1	37	1	22.33	22±1
				1	74	1	22.34	22±1
				36	0	2	22.13	22±1
				36	16	2	22.15	22±1
				36	35	2	22.14	22±1
				75	0	2	21.04	22±1
	21375	1747.5	QPSK	1	0	0	22.97	22±1
				1	37	0	22.95	22±1
1				74	0	22.94	22±1	
36				0	1	22.11	22±1	
36				16	1	22.13	22±1	
36				35	1	22.14	22±1	
75				0	1	22.12	22±1	
16QAM			1	0	1	22.51	22±1	
			1	37	1	22.51	22±1	
			1	74	1	22.53	22±1	
			36	0	2	22.11	22±1	
			36	16	2	22.14	22±1	
			36	35	2	22.15	22±1	
			75	0	2	21.00	22±1	

BW (MHz)	Ch	Freq. (MHz)	Mode	UL RB Allocation	UL RB Offset	MPR	Average power (dBm)	Tune up Power tolerant
10MHz	20800	2502	QPSK	1	0	0	23.21	22.5±1
				1	24	0	23.2	22.5±1
				1	49	0	23.2	22.5±1
				25	0	1	22.16	22.5±1
				25	12	1	22.18	22.5±1
				25	24	1	22.18	22.5±1
				50	0	1	22.15	22.5±1
			16QAM	1	0	1	22.02	22±1
				1	24	1	21.99	22±1
				1	49	1	22.01	22±1
				25	0	2	22.15	22±1
				25	12	2	22.17	22±1
				25	24	2	22.2	22±1
				50	0	2	21.04	22±1
	21100	2535	QPSK	1	0	0	22.99	22.5±1
				1	24	0	22.99	22.5±1
				1	49	0	22.97	22.5±1
				25	0	1	22.11	22.5±1
				25	12	1	22.1	22.5±1
				25	24	1	22.08	22.5±1
				50	0	1	22.09	22.5±1
			16QAM	1	0	1	22.64	22±1
				1	24	1	22.62	22±1
				1	49	1	22.65	22±1
				25	0	2	22.12	22±1
				25	12	2	22.1	22±1
				25	24	2	22.12	22±1
				50	0	2	21.05	22±1
	21400	2565	QPSK	1	0	0	23.06	22.5±1
				1	24	0	23.06	22.5±1
1				49	0	23.04	22.5±1	
25				0	1	22.04	22.5±1	
25				12	1	22.07	22.5±1	
25				24	1	22.09	22.5±1	
50				0	1	22.08	22.5±1	
16QAM			1	0	1	22.01	22±1	
			1	24	1	22.02	22±1	
			1	49	1	22.03	22±1	
			25	0	2	22.04	22±1	
			25	12	2	22.02	22±1	
			25	24	2	22	22±1	
			50	0	2	21.05	22±1	

BW (MHz)	Ch	Freq. (MHz)	Mode	UL RB Allocation	UL RB Offset	MPR	Average power (dBm)	Tune up Power tolerant
5MHz	19975	1712.5	QPSK	1	0	0	23.3	22.5±1
				1	12	0	<b>23.32</b>	22.5±1
				1	24	0	23.32	22.5±1
				12	0	1	22.2	22.5±1
				12	6	1	22.19	22.5±1
				12	11	1	22.21	22.5±1
				25	0	1	22.15	22.5±1
			16QAM	1	0	1	22.18	22±1
				1	12	1	22.2	22±1
				1	24	1	22.18	22±1
				12	0	2	22.19	22±1
				12	6	2	22.22	22±1
				12	11	2	22.23	22±1
				25	0	2	21.04	22±1
	20175	1732.5	QPSK	1	0	0	23.06	22.5±1
				1	12	0	23.06	22.5±1
				1	24	0	23.07	22.5±1
				12	0	1	22.14	22.5±1
				12	6	1	22.12	22.5±1
				12	11	1	22.12	22.5±1
				25	0	1	22.07	22.5±1
			16QAM	1	0	1	22.4	22±1
				1	12	1	22.41	22±1
				1	24	1	22.44	22±1
				12	0	2	22.15	22±1
				12	6	2	22.15	22±1
				12	11	2	22.15	22±1
				25	0	2	21	22.5±1
	20375	1752.5	QPSK	1	0	0	23.03	22.5±1
				1	12	0	23	22.5±1
1				24	0	23	22.5±1	
12				0	1	22.11	22.5±1	
12				6	1	22.09	22.5±1	
12				11	1	22.06	22.5±1	
25				0	1	22.04	22.5±1	
16QAM			1	0	1	22.01	21.3±1	
			1	12	1	22	21.3±1	
			1	24	1	22	21.3±1	
			12	0	2	22.12	21.3±1	
			12	6	2	22.1	21.3±1	
			12	11	2	22.08	21.3±1	
			25	0	2	21.13	21.3±1	



## ERP & EIRP

### EIRP for LTE Band II (Part 24E)

Frequency (MHz)	BW (MHz)	Modulation	RB Size/Offset	Substituted level (dBm)	Antenna Polarization	Antenna Gain correction (dBi)	Cable Loss (dB)	Absolute Level (dBm)	Limit (dBm)
1850.7	1.4	QPSK	1/0	17.65	V	7.88	0.85	24.68	33.01
1880	1.4	QPSK	1/0	17.66	V	7.88	0.85	<b>24.69</b>	33.01
1909.3	1.4	QPSK	1/0	17.65	V	7.88	0.85	24.68	33.01
1850.7	1.4	QPSK	1/0	16.48	H	7.88	0.85	23.51	33.01
1880	1.4	QPSK	1/0	16.52	H	7.88	0.85	23.55	33.01
1909.3	1.4	QPSK	1/0	16.45	H	7.88	0.85	23.48	33.01
1850.7	1.4	16-QAM	1/0	17.66	V	7.88	0.85	24.69	33.01
1880	1.4	16-QAM	1/0	17.63	V	7.88	0.85	24.66	33.01
1909.3	1.4	16-QAM	1/0	17.66	V	7.88	0.85	24.69	33.01
1850.7	1.4	16-QAM	1/0	16.49	H	7.88	0.85	23.52	33.01
1880	1.4	16-QAM	1/0	16.41	H	7.88	0.85	23.44	33.01
1909.3	1.4	16-QAM	1/0	16.52	H	7.88	0.85	23.55	33.01
1851.5	3	QPSK	1/0	17.62	V	7.88	0.85	24.65	33.01
1880	3	QPSK	1/0	17.65	V	7.88	0.85	24.68	33.01
1908.5	3	QPSK	1/0	17.52	V	7.88	0.85	24.55	33.01
1851.5	3	QPSK	1/0	16.45	H	7.88	0.85	23.48	33.01
1880	3	QPSK	1/0	16.5	H	7.88	0.85	23.53	33.01
1908.5	3	QPSK	1/0	16.43	H	7.88	0.85	23.46	33.01
1851.5	3	16-QAM	1/0	16.36	V	7.88	0.85	23.39	33.01
1880	3	16-QAM	1/0	16.52	V	7.88	0.85	23.55	33.01
1908.5	3	16-QAM	1/0	17.05	V	7.88	0.85	24.08	33.01
1851.5	3	16-QAM	1/0	15.28	H	7.88	0.85	22.31	33.01
1880	3	16-QAM	1/0	15.32	H	7.88	0.85	22.35	33.01
1908.5	3	16-QAM	1/0	15.88	H	7.88	0.85	22.91	33.01
1852.5	5	QPSK	1/24	17.65	V	7.88	0.85	24.68	33.01
1880	5	QPSK	1/0	17.66	V	7.88	0.85	24.69	33.01
1907.5	5	QPSK	1/24	17.65	V	7.88	0.85	24.68	33.01
1852.5	5	QPSK	1/24	16.47	H	7.88	0.85	23.5	33.01
1880	5	QPSK	1/0	16.55	H	7.88	0.85	23.58	33.01
1907.5	5	QPSK	1/24	16.44	H	7.88	0.85	23.47	33.01
1852.5	5	16-QAM	1/24	16.72	V	7.88	0.85	23.75	33.01
1880	5	16-QAM	1/0	17.02	V	7.88	0.85	24.05	33.01

1907.5	5	16-QAM	1/24	16.65	V	7.88	0.85	23.68	33.01
1852.5	5	16-QAM	1/24	15.58	H	7.88	0.85	22.61	33.01
1880	5	16-QAM	1/0	16.9	H	7.88	0.85	23.93	33.01
1907.5	5	16-QAM	1/24	15.39	H	7.88	0.85	22.42	33.01
1855	10	QPSK	1/0	17.63	V	7.88	0.85	24.66	33.01
1880	10	QPSK	1/0	17.66	V	7.88	0.85	24.69	33.01
1905	10	QPSK	1/49	17.63	V	7.88	0.85	24.66	33.01
1855	10	QPSK	1/0	16.42	H	7.88	0.85	23.45	33.01
1880	10	QPSK	1/0	16.58	H	7.88	0.85	23.61	33.01
1905	10	QPSK	1/49	16.36	H	7.88	0.85	23.39	33.01
1855	10	16-QAM	1/0	16.55	V	7.88	0.85	23.58	33.01
1880	10	16-QAM	1/0	16.53	V	7.88	0.85	23.56	33.01
1905	10	16-QAM	1/49	17.21	V	7.88	0.85	24.24	33.01
1855	10	16-QAM	1/0	15.38	H	7.88	0.85	22.41	33.01
1880	10	16-QAM	1/0	15.34	H	7.88	0.85	22.37	33.01
1905	10	16-QAM	1/49	15.49	H	7.88	0.85	22.52	33.01
1857.5	15	QPSK	1/0	17.66	V	7.88	0.85	24.69	33.01
1880	15	QPSK	1/0	17.66	V	7.88	0.85	24.69	33.01
1902.5	15	QPSK	1/0	17.66	V	7.88	0.85	24.69	33.01
1857.5	15	QPSK	1/0	16.35	H	7.88	0.85	23.38	33.01
1880	15	QPSK	1/0	16.57	H	7.88	0.85	23.6	33.01
1902.5	15	QPSK	1/0	16.56	H	7.88	0.85	23.59	33.01
1857.5	15	16-QAM	1/0	17.62	V	7.88	0.85	24.65	33.01
1880	15	16-QAM	1/0	16.86	V	7.88	0.85	23.89	33.01
1902.5	15	16-QAM	1/0	17.24	V	7.88	0.85	24.27	33.01
1857.5	15	16-QAM	1/0	16.58	H	7.88	0.85	23.61	33.01
1880	15	16-QAM	1/0	15.73	H	7.88	0.85	22.76	33.01
1902.5	15	16-QAM	1/0	16.08	H	7.88	0.85	23.11	33.01
1860	20	QPSK	1/0	17.66	V	7.88	0.85	24.69	33.01
1880	20	QPSK	1/0	17.62	V	7.88	0.85	24.65	33.01
1900	20	QPSK	1/0	17.82	V	7.88	0.85	<b>24.85</b>	33.01
1860	20	QPSK	1/0	16.62	H	7.88	0.85	23.65	33.01
1880	20	QPSK	1/0	16.56	H	7.88	0.85	23.59	33.01
1900	20	QPSK	1/0	16.68	H	7.88	0.85	23.71	33.01
1860	20	16-QAM	1/0	16.6	V	7.88	0.85	23.63	33.01
1880	20	16-QAM	1/0	16.85	V	7.88	0.85	23.88	33.01
1900	20	16-QAM	1/0	17.13	V	7.88	0.85	24.16	33.01
1860	20	16-QAM	1/0	15.53	H	7.88	0.85	22.56	33.01



Test Report	17070226-FCC-R5
Page	31 of 112

1880	20	16-QAM	1/0	15.7	H	7.88	0.85	22.73	33.01
1900	20	16-QAM	1/0	15.95	H	7.88	0.85	22.98	33.01

### EIRP for LTE Band IV (Part 27)

Frequency (MHz)	BW (MHz)	Modulation	RB Size/Offset	Substituted level (dBm)	Antenna Polarization	Antenna Gain correction (dBi)	Cable Loss (dB)	Absolute Level (dBm)	Limit (dBm)
1710.7	1.4	QPSK	1/0	17.48	V	7.95	0.79	24.64	30
1732.5	1.4	QPSK	1/0	17.64	V	7.95	0.79	<b>24.80</b>	30
1754.3	1.4	QPSK	1/0	17.52	V	7.95	0.79	24.68	30
1710.7	1.4	QPSK	1/0	16.41	H	7.95	0.79	23.57	30
1732.5	1.4	QPSK	1/0	16.55	H	7.95	0.79	23.71	30
1754.3	1.4	QPSK	1/0	16.46	H	7.95	0.79	23.62	30
1710.7	1.4	16-QAM	1/5	17.47	V	7.95	0.79	24.63	30
1732.5	1.4	16-QAM	1/0	16.5	V	7.95	0.79	23.66	30
1754.3	1.4	16-QAM	1/0	17.52	V	7.95	0.79	24.68	30
1710.7	1.4	16-QAM	1/5	16.35	H	7.95	0.79	23.51	30
1732.5	1.4	16-QAM	1/0	15.19	H	7.95	0.79	22.35	30
1754.3	1.4	16-QAM	1/0	16.32	H	7.95	0.79	23.48	30
1711.5	3	QPSK	1/0	17.4	V	7.95	0.79	24.56	30
1732.5	3	QPSK	1/0	17.53	V	7.95	0.79	24.69	30
1753.5	3	QPSK	1/0	17.33	V	7.95	0.79	24.49	30
1711.5	3	QPSK	1/0	16.16	H	7.95	0.79	23.32	30
1732.5	3	QPSK	1/0	16.44	H	7.95	0.79	23.6	30
1753.5	3	QPSK	1/0	16.13	H	7.95	0.79	23.29	30
1711.5	3	16-QAM	1/0	16.27	V	7.95	0.79	23.43	30
1732.5	3	16-QAM	1/0	16.49	V	7.95	0.79	23.65	30
1753.5	3	16-QAM	1/0	16.91	V	7.95	0.79	24.07	30
1711.5	3	16-QAM	1/0	15.09	H	7.95	0.79	22.25	30
1732.5	3	16-QAM	1/0	15.38	H	7.95	0.79	22.54	30
1753.5	3	16-QAM	1/0	16.73	H	7.95	0.79	23.89	30
1712.5	5	QPSK	1/0	17.53	V	7.95	0.79	24.69	30
1732.5	5	QPSK	1/0	17.53	V	7.95	0.79	24.69	30
1752.5	5	QPSK	1/24	17.53	V	7.95	0.79	24.69	30
1712.5	5	QPSK	1/0	16.27	H	7.95	0.79	23.43	30
1732.5	5	QPSK	1/0	16.4	H	7.95	0.79	23.56	30
1752.5	5	QPSK	1/24	16.36	H	7.95	0.79	23.52	30
1712.5	5	16-QAM	1/0	16.57	V	7.95	0.79	23.73	30
1732.5	5	16-QAM	1/0	16.8	V	7.95	0.79	23.96	30
1752.5	5	16-QAM	1/24	16.51	V	7.95	0.79	23.67	30
1712.5	5	16-QAM	1/0	15.45	H	7.95	0.79	22.61	30
1732.5	5	16-QAM	1/0	15.69	H	7.95	0.79	22.85	30

1752.5	5	16-QAM	1/24	15.18	H	7.95	0.79	22.34	30
1715	10	QPSK	1/0	17.5	V	7.95	0.79	24.66	30
1732.5	10	QPSK	1/49	17.52	V	7.95	0.79	24.68	30
1750	10	QPSK	1/0	17.42	V	7.95	0.79	24.58	30
1715	10	QPSK	1/0	16.22	H	7.95	0.79	23.38	30
1732.5	10	QPSK	1/49	16.08	H	7.95	0.79	23.24	30
1750	10	QPSK	1/0	16.15	H	7.95	0.79	23.31	30
1715	10	16-QAM	1/0	16.4	V	7.95	0.79	23.56	30
1732.5	10	16-QAM	1/49	16.52	V	7.95	0.79	23.68	30
1750	10	16-QAM	1/0	16.97	V	7.95	0.79	24.13	30
1715	10	16-QAM	1/0	15.1	H	7.95	0.79	22.26	30
1732.5	10	16-QAM	1/49	15.37	H	7.95	0.79	22.53	30
1750	10	16-QAM	1/0	15.74	H	7.95	0.79	22.9	30
1717.5	15	QPSK	1/0	17.49	V	7.95	0.79	24.65	30
1732.5	15	QPSK	1/74	17.53	V	7.95	0.79	24.69	30
1747.5	15	QPSK	1/0	17.5	V	7.95	0.79	24.66	30
1717.5	15	QPSK	1/0	16.46	H	7.95	0.79	23.62	30
1732.5	15	QPSK	1/74	16.43	H	7.95	0.79	23.59	30
1747.5	15	QPSK	1/0	16.31	H	7.95	0.79	23.47	30
1717.5	15	16-QAM	1/0	16.5	V	7.95	0.79	23.66	30
1732.5	15	16-QAM	1/74	16.77	V	7.95	0.79	23.93	30
1747.5	15	16-QAM	1/0	17.02	V	7.95	0.79	24.18	30
1717.5	15	16-QAM	1/0	15.25	H	7.95	0.79	22.41	30
1732.5	15	16-QAM	1/74	15.7	H	7.95	0.79	22.86	30
1747.5	15	16-QAM	1/0	16.79	H	7.95	0.79	23.95	30
1720	20	QPSK	1/99	17.53	V	7.95	0.79	24.69	30
1732.5	20	QPSK	1/99	17.49	V	7.95	0.79	24.65	30
1745	20	QPSK	1/0	17.53	V	7.95	0.79	24.69	30
1720	20	QPSK	1/99	16.35	H	7.95	0.79	23.51	30
1732.5	20	QPSK	1/99	16.27	H	7.95	0.79	23.43	30
1745	20	QPSK	1/0	16.21	H	7.95	0.79	23.37	30
1720	20	16-QAM	1/99	16.51	V	7.95	0.79	23.67	30
1732.5	20	16-QAM	1/99	16.71	V	7.95	0.79	23.87	30
1745	20	16-QAM	1/0	16.93	V	7.95	0.79	24.09	30
1720	20	16-QAM	1/99	15.39	H	7.95	0.79	22.55	30
1732.5	20	16-QAM	1/99	15.58	H	7.95	0.79	22.74	30
1745	20	16-QAM	1/0	16.77	H	7.95	0.79	23.93	30

### ERP for LTE Band VII (Part 27)

Frequency (MHz)	BW (MHz)	Modulation	RB Size/Offset	Substituted level (dBm)	Antenna Polarization	Antenna Gain correction (dBi)	Cable Loss (dB)	Absolute Level (dBm)	Limit (dBm)
2502.5	5	QPSK	1/0	17.72	V	8.93	0.83	<b>25.82</b>	30
2535	5	QPSK	1/0	17.47	V	8.93	0.83	25.57	30
2567.5	5	QPSK	1/24	17.43	V	8.93	0.83	25.53	30
2502.5	5	QPSK	1/0	16.6	H	8.93	0.83	24.7	30
2535	5	QPSK	1/0	16.24	H	8.93	0.83	24.34	30
2567.5	5	QPSK	1/24	16.21	H	8.93	0.83	24.31	30
2502.5	5	16-QAM	1/0	16.63	V	8.93	0.83	24.73	30
2535	5	16-QAM	1/0	16.84	V	8.93	0.83	24.94	30
2567.5	5	16-QAM	1/24	16.52	V	8.93	0.83	24.62	30
2502.5	5	16-QAM	1/0	15.56	H	8.93	0.83	23.66	30
2535	5	16-QAM	1/0	15.79	H	8.93	0.83	23.89	30
2567.5	5	16-QAM	1/24	15.33	H	8.93	0.83	23.43	30
2505	10	QPSK	1/0	17.61	V	8.93	0.83	25.71	30
2535	10	QPSK	1/49	17.39	V	8.93	0.83	25.49	30
2565	10	QPSK	1/0	17.46	V	8.93	0.83	25.56	30
2505	10	QPSK	1/0	16.48	H	8.93	0.83	24.58	30
2535	10	QPSK	1/49	16.15	H	8.93	0.83	24.25	30
2565	10	QPSK	1/0	16.26	H	8.93	0.83	24.36	30
2505	10	16-QAM	1/0	16.6	V	8.93	0.83	24.7	30
2535	10	16-QAM	1/49	17.05	V	8.93	0.83	25.15	30
2565	10	16-QAM	1/0	16.44	V	8.93	0.83	24.54	30
2505	10	16-QAM	1/0	15.42	H	8.93	0.83	23.52	30
2535	10	16-QAM	1/49	15.98	H	8.93	0.83	24.08	30
2565	10	16-QAM	1/0	15.31	H	8.93	0.83	23.41	30
2507.5	15	QPSK	1/0	17.65	V	8.93	0.83	25.75	30
2535	15	QPSK	1/74	17.42	V	8.93	0.83	25.52	30
2562.5	15	QPSK	1/0	17.37	V	8.93	0.83	25.47	30
2507.5	15	QPSK	1/0	16.52	H	8.93	0.83	24.62	30
2535	15	QPSK	1/74	16.27	H	8.93	0.83	24.37	30
2562.5	15	QPSK	1/0	16.31	H	8.93	0.83	24.41	30
2507.5	15	16-QAM	1/0	16.69	V	8.93	0.83	24.79	30
2535	15	16-QAM	1/74	16.74	V	8.93	0.83	24.84	30
2562.5	15	16-QAM	1/0	16.93	V	8.93	0.83	25.03	30

2507.5	15	16-QAM	1/0	15.55	H	8.93	0.83	23.65	30
2535	15	16-QAM	1/74	15.63	H	8.93	0.83	23.73	30
2562.5	15	16-QAM	1/0	15.81	H	8.93	0.83	23.91	30
2510	20	QPSK	1/99	17.67	V	8.93	0.83	25.77	30
2535	20	QPSK	1/99	17.42	V	8.93	0.83	25.52	30
2560	20	QPSK	1/0	17.46	V	8.93	0.83	25.56	30
2510	20	QPSK	1/99	16.5	H	8.93	0.83	24.6	30
2535	20	QPSK	1/99	16.25	H	8.93	0.83	24.35	30
2560	20	QPSK	1/0	16.34	H	8.93	0.83	24.44	30
2510	20	16-QAM	1/99	16.57	V	8.93	0.83	24.67	30
2535	20	16-QAM	1/99	16.75	V	8.93	0.83	24.85	30
2560	20	16-QAM	1/0	16.82	V	8.93	0.83	24.92	30
2510	20	16-QAM	1/99	15.45	H	8.93	0.83	23.55	30
2535	20	16-QAM	1/99	15.62	H	8.93	0.83	23.72	30
2560	20	16-QAM	1/0	15.76	H	8.93	0.83	23.86	30

### 6.3 Peak-Average Ratio

Temperature	24°C
Relative Humidity	55%
Atmospheric Pressure	1013mbar
Test date :	April 12, 2017
Tested By :	Loren Luo

Requirement(s):

Spec	Item	Requirement	Applicable
§24.232(d) § 27.50(d)	a)	The peak-to-average ratio (PAR) of the transmission may not exceed 13 dB.	<input checked="" type="checkbox"/>

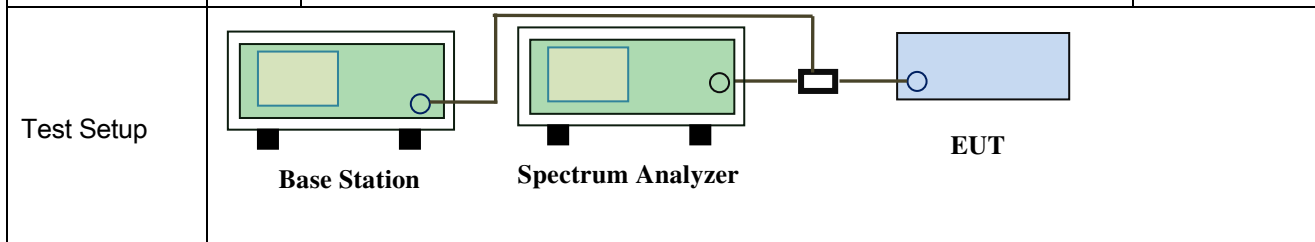

Test Procedure	<p><b>According with KDB 971168 v02r02</b></p> <p><b>5.7.2 Alternate procedure for PAPR</b></p> <p><b>5.1.2 Peak power measurements with a peak power meter</b></p> <p>The total peak output power may be measured using a broadband peak RF power meter. The power meter must have a video bandwidth that is greater than or equal to the emission bandwidth and utilize a fast-responding diode detector.</p> <p><b>5.2.3 Average power measurement with average power meter</b></p> <p>As an alternative to the use of a spectrum/signal analyzer or EMI receiver to perform a measurement of the total in-band average output power, a wideband RF average power meter with a thermocouple detector or equivalent can be used under certain conditions</p> <p>If the EUT can be configured to transmit continuously (i.e., the burst duty</p>
----------------	---



	<p>cycle <math>\geq</math> 98%) and at all times the EUT is transmitting at its maximum output power level, then a conventional wide-band RF power meter can be used. If the EUT cannot be configured to transmit continuously (i.e., the burst duty cycle <math>&lt;</math> 98%), then there are two options for the use of an average power meter. First, a gated average power meter can be used to perform the measurement if the gating parameters can be adjusted such that the power is measured only over active transmission bursts at maximum output power levels. A conventional average power meter can also be used if the measured burst duty cycle is constant (i.e., duty cycle variations are less than <math>\pm</math> 2 percent) by performing the measurement over the on/off burst cycles and then correcting (increasing) the measured level by a factor equal to <math>10\log(1/\text{duty cycle})</math></p>
Remark	
Result	<input checked="" type="checkbox"/> Pass <input type="checkbox"/> Fail

Test Data     Yes                       N/A  
 Test Plot     Yes (See below)             N/A

### LTE Band II (part 24E)

BW(MHz)	Frequency (MHz)	Mode	Modulation	Conducted Power (dBm)		Peak-Average Ratio (PAR)
				Peak	Average	
1.4	1880	RB 1/0	QPSK	25.66	22.99	2.67
			16QAM	25.35	21.9	3.45
3	1880	RB 1/0	QPSK	25.62	22.98	2.64
			16QAM	25.79	21.82	3.97
5	1880	RB 1/0	QPSK	25.61	22.99	2.62
			16QAM	25.43	22.3	3.13
10	1880	RB 1/0	QPSK	25.43	22.99	2.44
			16QAM	25.65	21.82	3.83
15	1880	RB 1/0	QPSK	25.68	22.99	2.69
			16QAM	25.27	22.19	3.08
20	1880	RB 1/0	QPSK	25.55	22.91	2.64
			16QAM	25.75	22.15	3.6

### LTE Band IV (part 27)

BW(MHz)	Frequency (MHz)	Mode	Modulation	Conducted Power (dBm)		Peak-Average Ratio (PAR)
				Peak	Average	
1.4	1732.5	RB 1/0	QPSK	25.46	23.05	2.41
			16QAM	25.43	21.87	3.56
3	1732.5	RB 1/0	QPSK	25.42	22.99	2.43
			16QAM	25.12	21.9	3.22
5	1732.5	RB 1/0	QPSK	25.36	22.99	2.37
			16QAM	25.45	22.24	3.21
10	1732.5	RB 1/0	QPSK	25.26	22.97	2.29
			16QAM	25.36	21.84	3.52
15	1732.5	RB 1/0	QPSK	25.56	22.99	2.57
			16QAM	25.33	22.19	3.14
20	1732.5	RB 1/0	QPSK	25.75	22.95	2.8
			16QAM	25.49	22.17	3.32

**LTE Band VII (part 27)**

BW(MHz)	Frequency (MHz)	Mode	Modulation	Conducted Power (dBm)		Peak-Average Ratio (PAR)
				Peak	Average	
5	2535	RB 1/0	QPSK	25.3	23.06	2.24
			16QAM	25.36	22.4	2.96
10	2535	RB 1/0	QPSK	25.15	22.99	2.16
			16QAM	25.46	2.64	22.82
15	2535	RB 1/0	QPSK	25.22	23.01	2.21
			16QAM	25.36	22.32	3.04
20	2535	RB 1/0	QPSK	25.56	23.02	2.54
			16QAM	25.43	22.34	3.09

## 6.4 Occupied Bandwidth

Temperature	24°C
Relative Humidity	55%
Atmospheric Pressure	1013mbar
Test date :	April 12, 2017
Tested By :	Loren Luo

### Requirement(s):

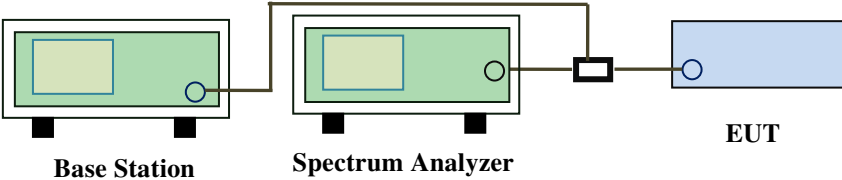
Spec	Item	Requirement	Applicable
§2.1049, §22.917, §22.905 §24.238 §27.53(a)	a)	99% Occupied Bandwidth(kHz)	<input checked="" type="checkbox"/>
	b)	26 dB Bandwidth(kHz)	<input checked="" type="checkbox"/>
Test Setup	 <p style="text-align: center;">Base Station      Spectrum Analyzer      EUT</p>		
Test Procedure	<ul style="list-style-type: none"> <li>- The EUT was connected to Spectrum Analyzer and Base Station via power divider.</li> <li>- The 99% and 26 dB occupied bandwidth (BW) of the middle channel for the highest RF powers.</li> </ul>		
Remark			
Result	<input checked="" type="checkbox"/> Pass <input type="checkbox"/> Fail		

Test Data     Yes       N/A

Test Plot     Yes (See below)       N/A

### LTE Band II (Part 24E)

BW(MHz)	Channel	Frequency (MHz)	Modulation	99% Occupied Bandwidth (MHz)	26 dB Bandwidth (MHz)
1.4	18607	1850	16QAM	1.0939	1.253
			QPSK	1.1042	1.283
1.4	18900	1880	16QAM	1.1013	1.278
			QPSK	1.1034	1.262
1.4	19193	1909	16QAM	1.1056	1.279
			QPSK	1.0981	1.269
3	18615	1852	16QAM	2.7384	3.012
			QPSK	2.7401	3.033
3	18900	1880	16QAM	2.7409	3.043
			QPSK	2.7442	3.039
3	19185	1909	16QAM	2.7471	3.022
			QPSK	2.7426	3.050
5	18625	1853	16QAM	4.5323	5.038
			QPSK	4.5433	5.087
5	18900	1880	16QAM	4.5414	5.038
			QPSK	4.5366	5.018
5	19175	1908	16QAM	4.5312	5.071
			QPSK	4.5293	5.037
10	18650	1855	16QAM	9.0605	10.10
			QPSK	9.0419	10.07
10	18900	1880	16QAM	9.0443	10.08
			QPSK	9.0441	10.10
10	19150	1905	16QAM	9.0577	10.02
			QPSK	9.0569	10.17
15	18675	1858	16QAM	13.492	14.77
			QPSK	13.460	14.67
15	18900	1880	16QAM	13.487	14.72
			QPSK	13.493	14.77
15	19125	1903	16QAM	13.468	14.71
			QPSK	13.473	14.77

20	18700	1860	16QAM	17.943	19.51
			QPSK	17.904	19.37
20	18900	1880	16QAM	17.935	19.36
			QPSK	17.917	19.61
20	19100	1900	16QAM	17.910	19.33
			QPSK	17.943	19.25

### LTE Band IV (Part 27)

BW(MHz)	Channel	Frequency (MHz)	Modulation	99% Occupied Bandwidth (MHz)	26 dB Bandwidth (MHz)
1.4	19957	1711	16QAM	1.0962	1.273
			QPSK	1.1035	1.287
1.4	20175	1733	16QAM	1.1012	1.266
			QPSK	1.1043	1.268
1.4	20393	1754	16QAM	1.1014	1.272
			QPSK	1.1061	1.294
3	19965	1712	16QAM	2.7384	3.047
			QPSK	2.7510	3.033
3	20175	1733	16QAM	2.7334	3.048
			QPSK	2.7333	3.057
3	20385	1754	16QAM	2.7492	3.065
			QPSK	2.7434	3.055
5	19975	1713	16QAM	4.5277	5.067
			QPSK	4.5320	5.026
5	20175	1733	16QAM	4.5453	5.057
			QPSK	4.5218	5.020
5	20375	1753	16QAM	4.5298	5.054
			QPSK	4.5359	5.029
10	20000	1715	16QAM	9.0598	10.08
			QPSK	9.0538	10.12
10	20175	1733	16QAM	9.0649	10.06
			QPSK	9.0592	10.10
10	20350	1750	16QAM	9.0438	10.10
			QPSK	9.0801	10.19
15	20025	1718	16QAM	13.483	14.85
			QPSK	13.455	14.74
15	20175	1733	16QAM	13.487	14.81
			QPSK	13.493	14.79
15	20325	1748	16QAM	13.500	14.86
			QPSK	13.507	14.97

20	20050	1720	16QAM	17.920	19.45
			QPSK	17.916	19.26
20	20175	1733	16QAM	17.914	19.45
			QPSK	17.910	19.37
20	20300	1745	16QAM	17.949	19.29
			QPSK	17.944	19.43



**LTE Band VII (Part 27) result**

BW(MHz)	Channel	Frequency (MHz)	Modulation	99% Occupied Bandwidth (MHz)	26 dB Bandwidth (MHz)
5	20775	2503	16QAM	4.5352	5.041
			QPSK	4.5339	5.059
5	21100	2535	16QAM	4.5290	5.046
			QPSK	4.5217	5.053
5	21425	2568	16QAM	4.5237	5.040
			QPSK	4.5299	5.047
10	20800	2505	16QAM	9.0563	10.08
			QPSK	9.0406	10.02
10	21100	2535	16QAM	9.0382	10.09
			QPSK	9.0643	10.07
10	21400	2565	16QAM	9.0760	10.07
			QPSK	9.0482	10.11
15	20825	2508	16QAM	13.493	14.80
			QPSK	13.462	14.85
15	21100	2535	16QAM	13.479	14.80
			QPSK	13.495	14.85
15	21400	2563	16QAM	13.516	14.82
			QPSK	13.520	14.99
20	20850	2510	16QAM	17.913	19.31
			QPSK	17.909	19.43
20	21100	2535	16QAM	17.940	19.34
			QPSK	17.929	19.50
20	21350	2560	16QAM	17.902	19.49
			QPSK	17.934	19.36

### Test Plots

#### LTE Band II (Part 24E)

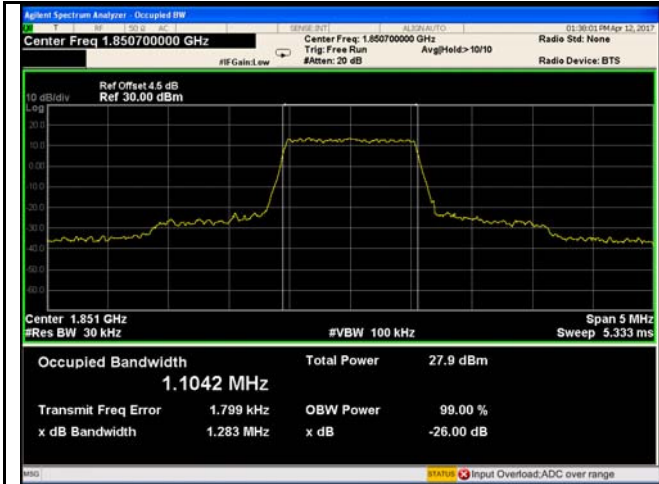

LTE band II - Low CH QPSK-1.4

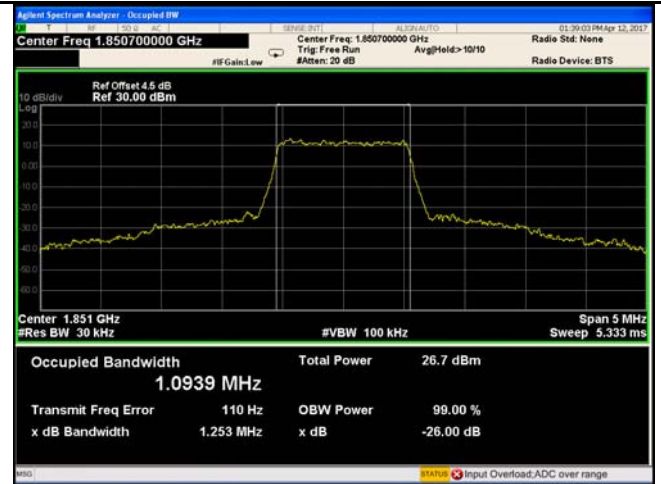

LTE band II - Low CH 16QAM-1.4

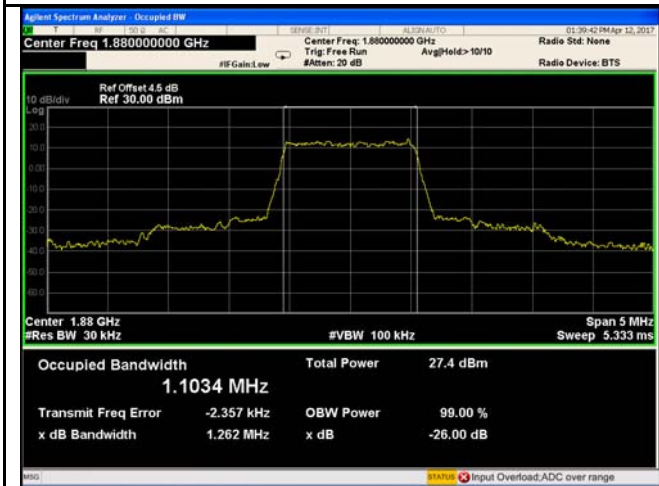

LTE band II - Middle CH QPSK-1.4

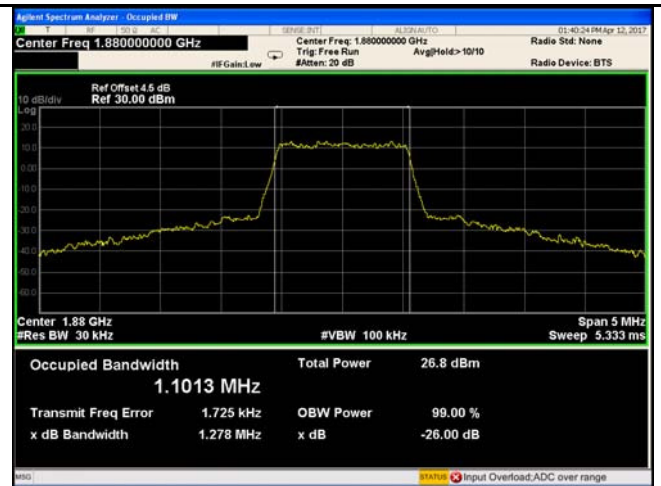

LTE band II - Middle CH 16QAM-1.4

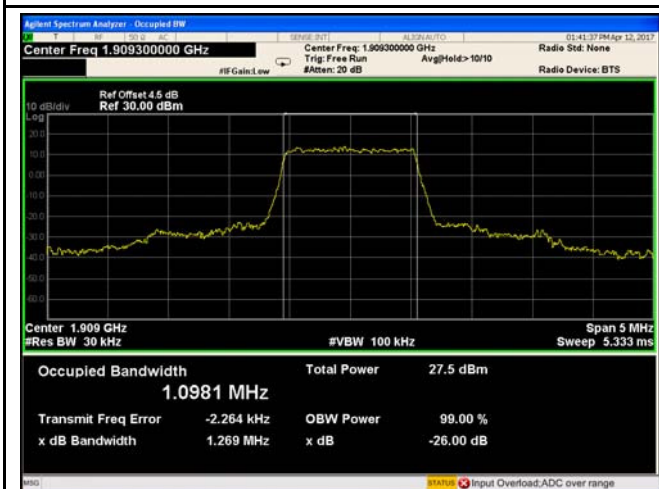

LTE band II - High CH QPSK-1.4

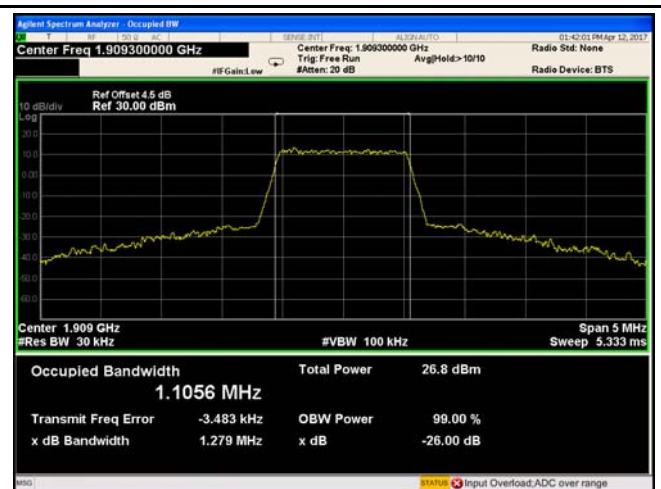

LTE band II - High CH 16QAM-1.4

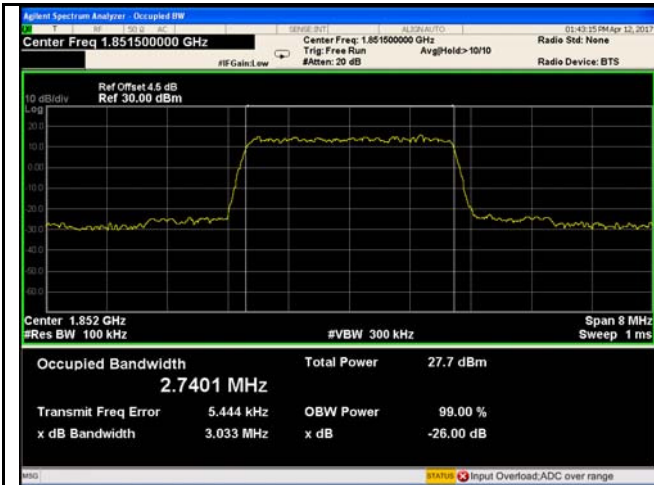

LTE band II - Low CH QPSK-3

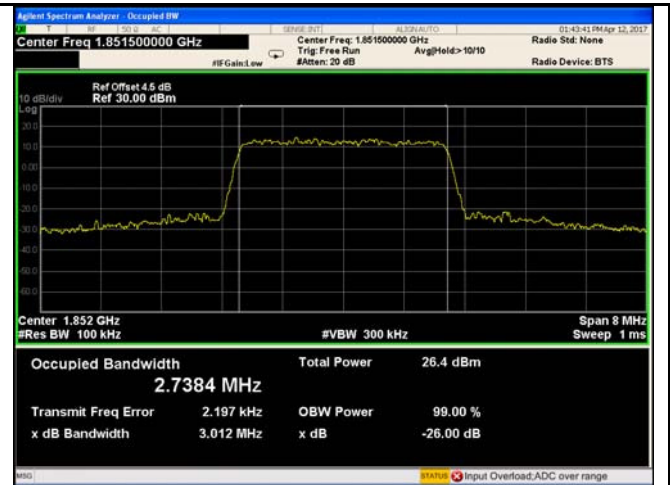

LTE band II - Low CH 16QAM-3

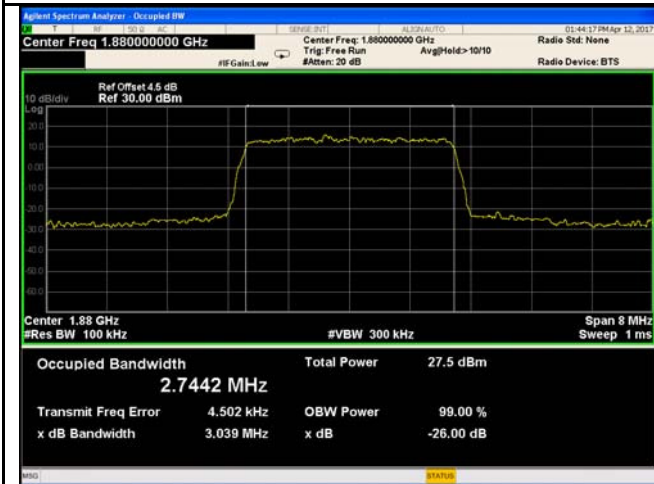

LTE band II - Middle CH QPSK-3



LTE band II - Middle CH 16QAM-3

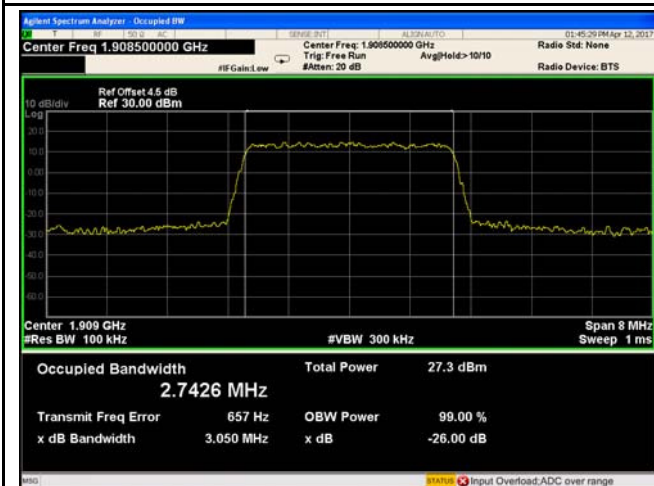

LTE band II - High CH QPSK-3

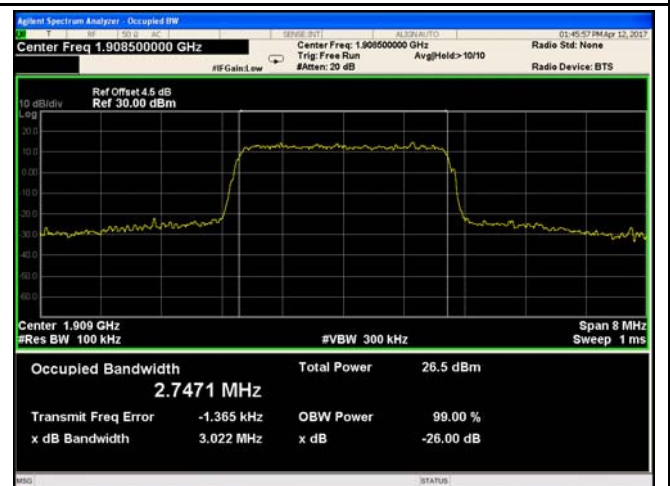

LTE band II - High CH 16QAM-3

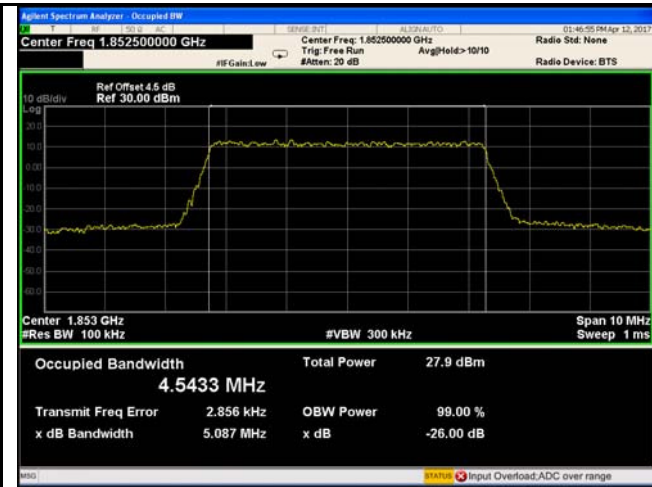

LTE band II - Low CH QPSK-5

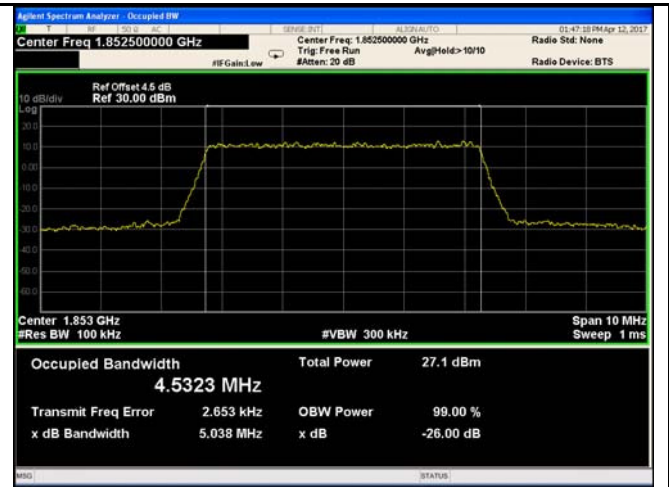

LTE band II - Low CH 16QAM-5

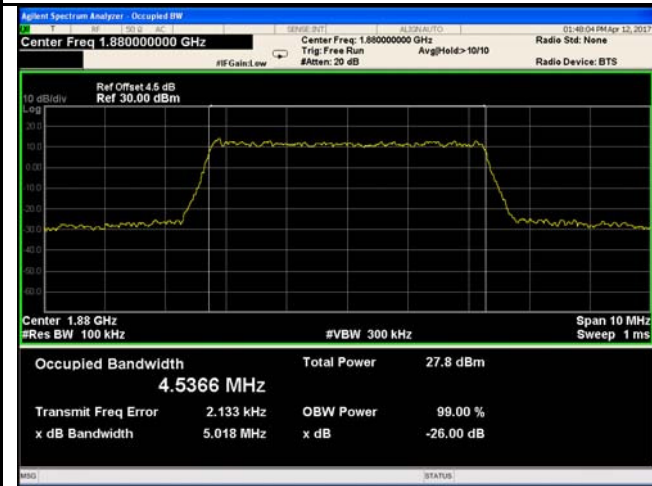

LTE band II - Middle CH QPSK-5



LTE band II - Middle CH 16QAM-5

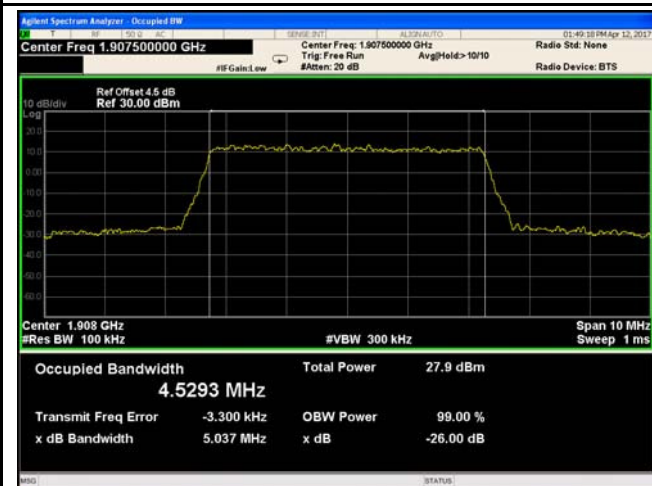

LTE band II - High CH QPSK-5

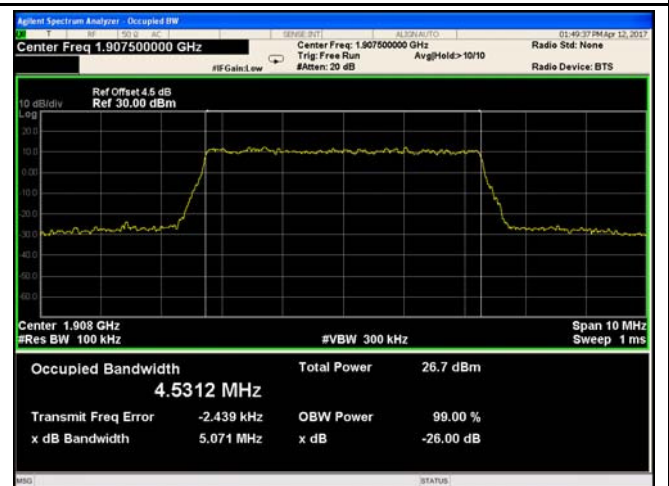

LTE band II - High CH 16QAM-5

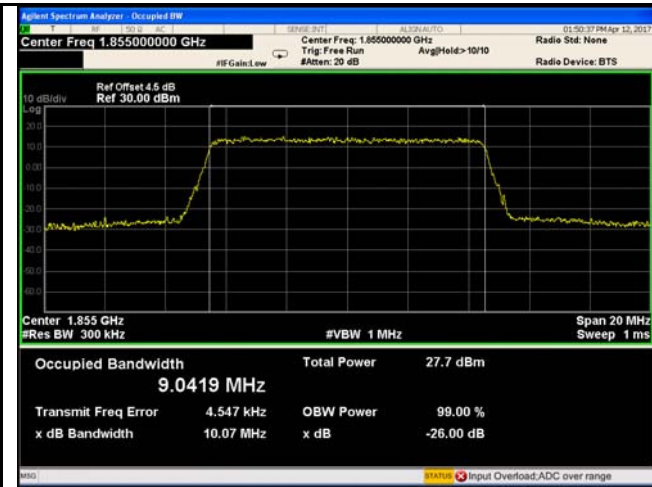

LTE band II - Low CH QPSK-10



LTE band II - Low CH 16QAM-10

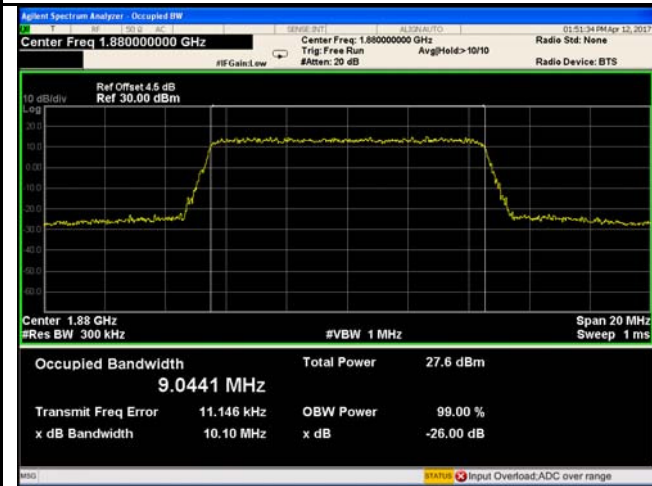

LTE band II - Middle CH QPSK-10



LTE band II - Middle CH 16QAM-10

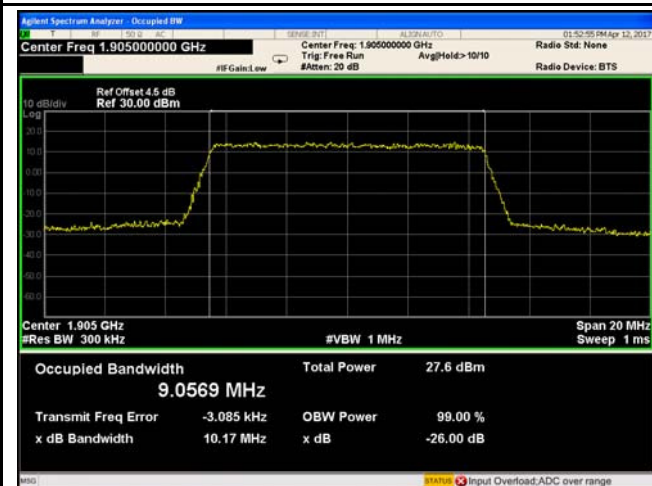

LTE band II - High CH QPSK-10

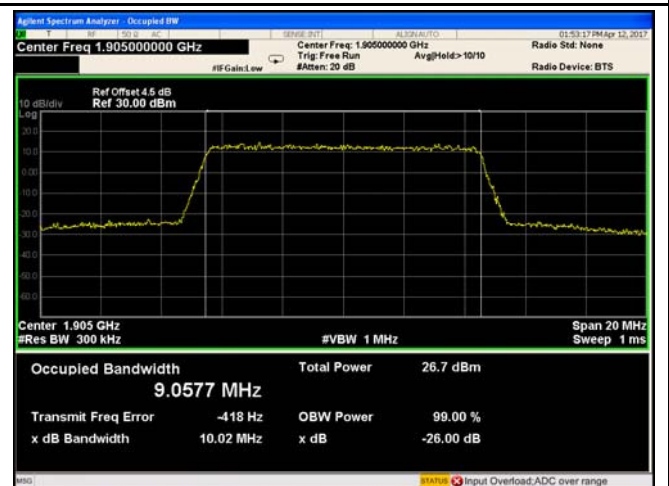

LTE band II - High CH 16QAM-10



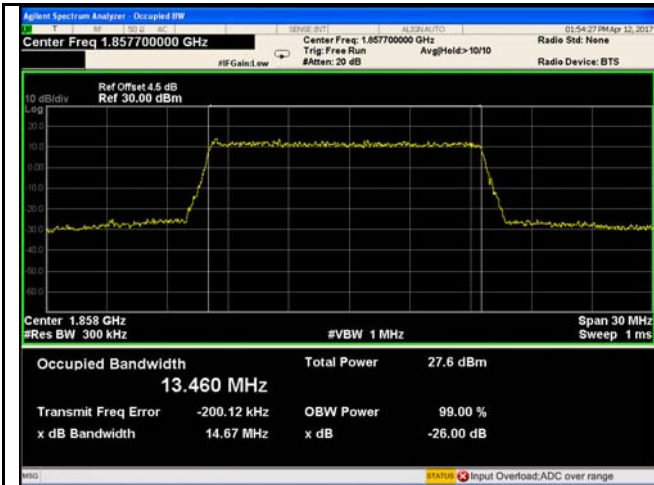

LTE band II - Low CH QPSK-15

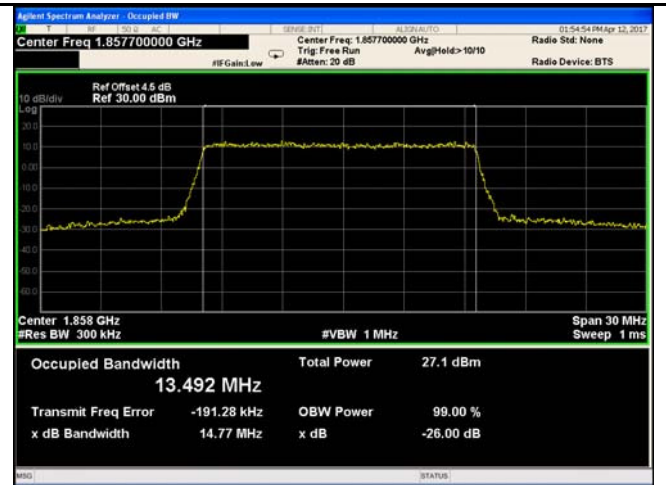

LTE band II - Low CH 16QAM-15

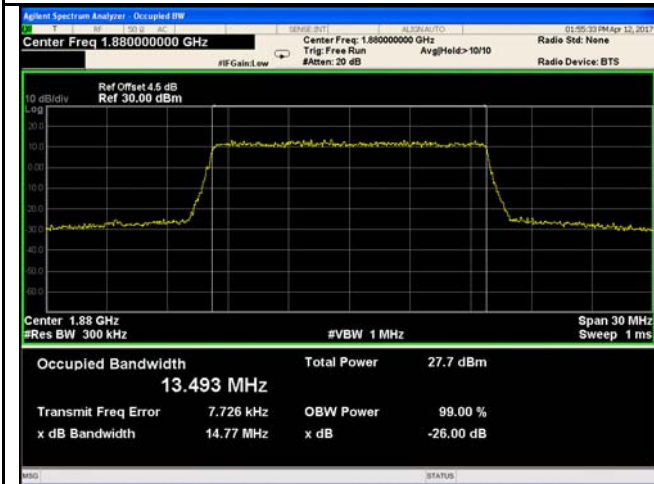

LTE band II - Middle CH QPSK-15

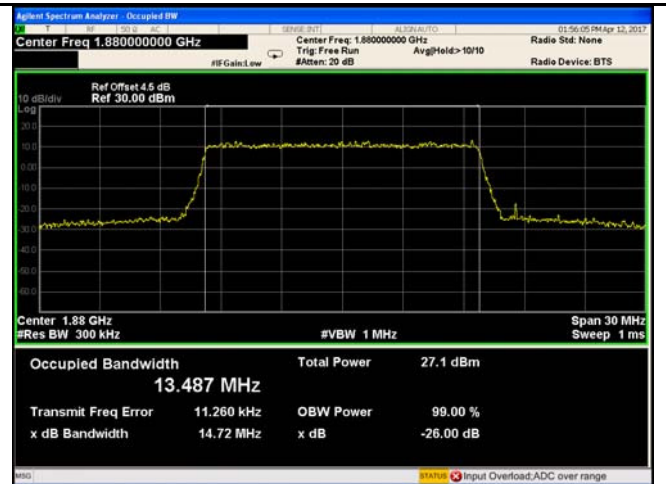

LTE band II - Middle CH 16QAM-15

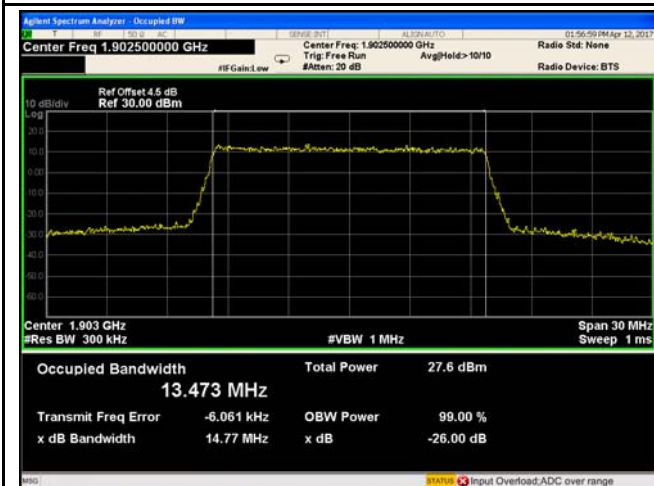

LTE band II - High CH QPSK-15

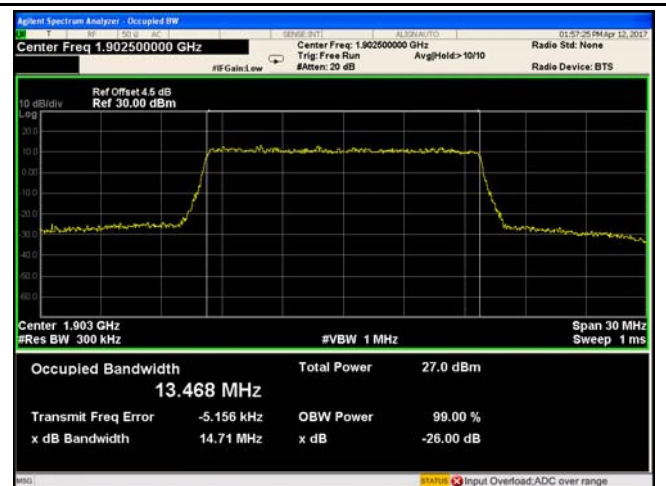

LTE band II - High CH 16QAM-15

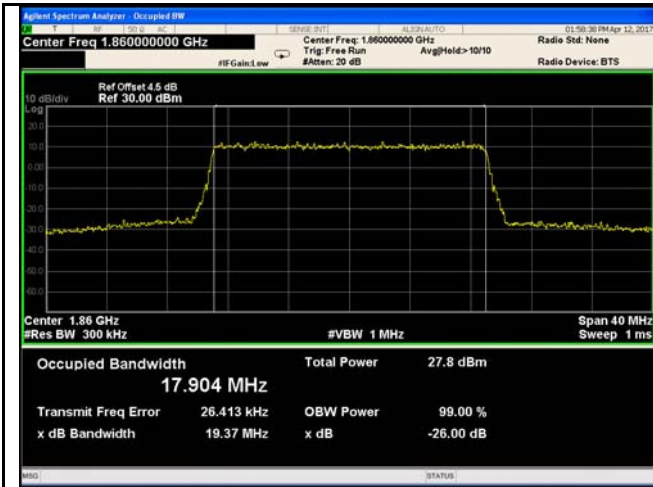

LTE band II - Low CH QPSK-20

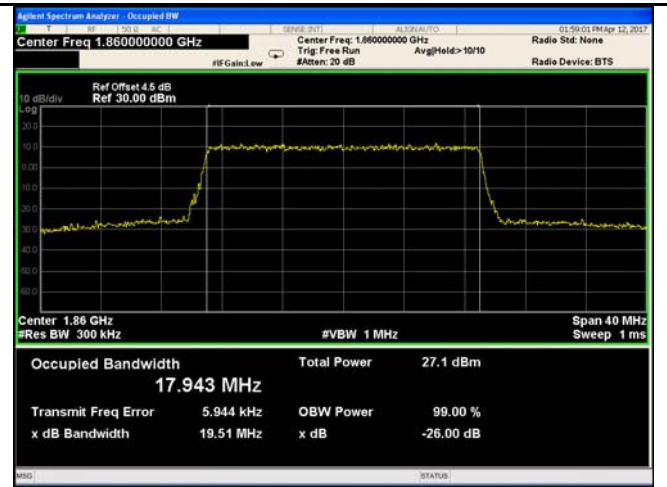

LTE band II - Low CH 16QAM-20

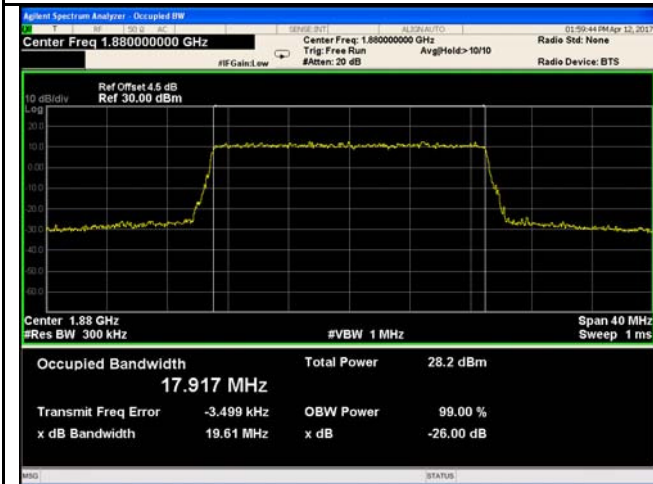

LTE band II - Middle CH QPSK-20

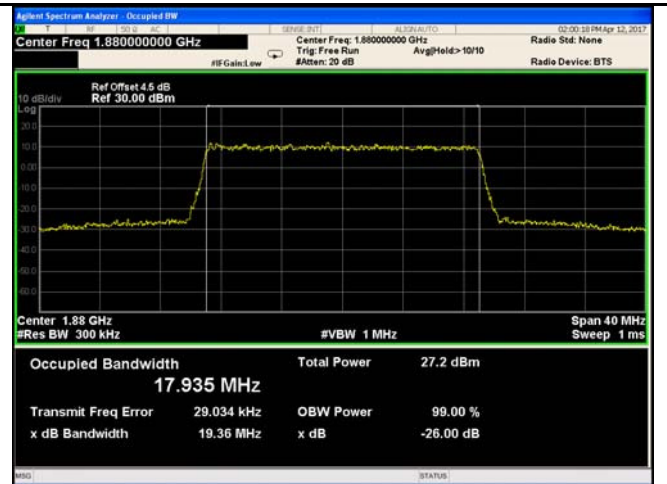

LTE band II - Middle CH 16QAM-20

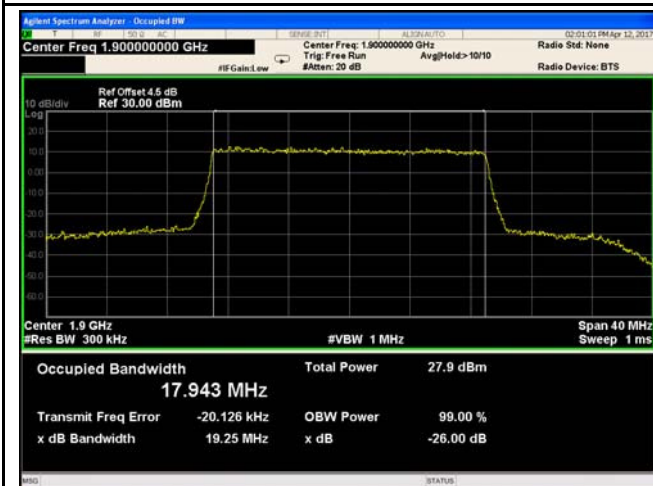

LTE band II - High CH QPSK-20

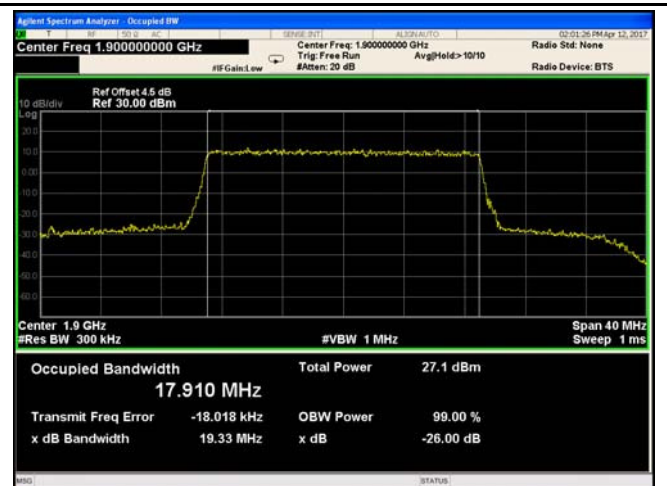

LTE band II - High CH 16QAM-20

### LTE band IV (Part 27)

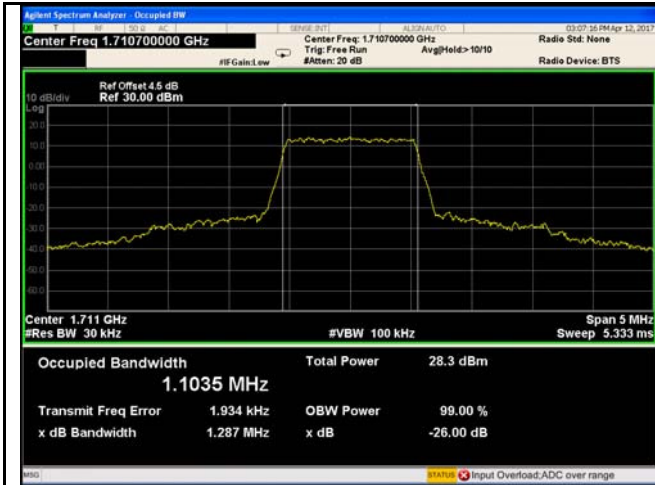

LTE band IV - Low CH QPSK-1.4



LTE band IV - Low CH 16QAM-1.4

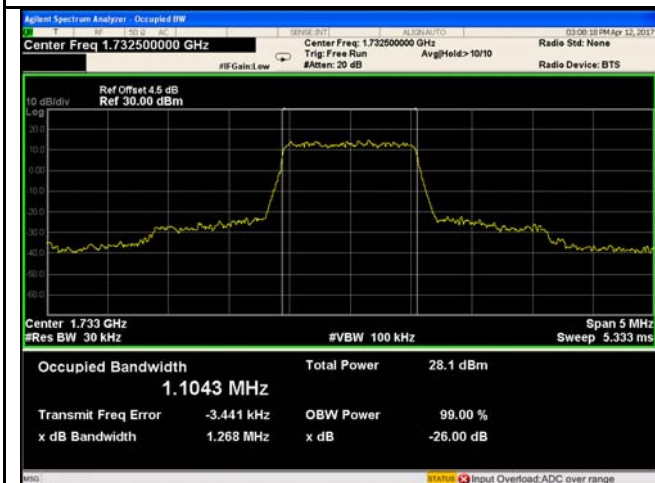

LTE band IV - Middle CH QPSK-1.4

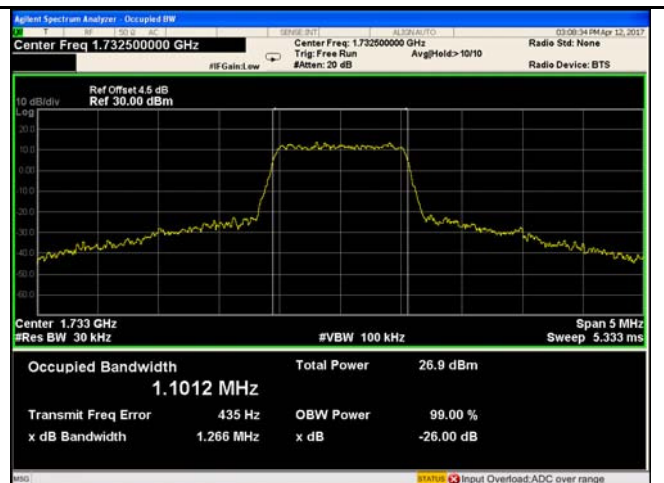

LTE band IV - Middle CH 16QAM-1.4

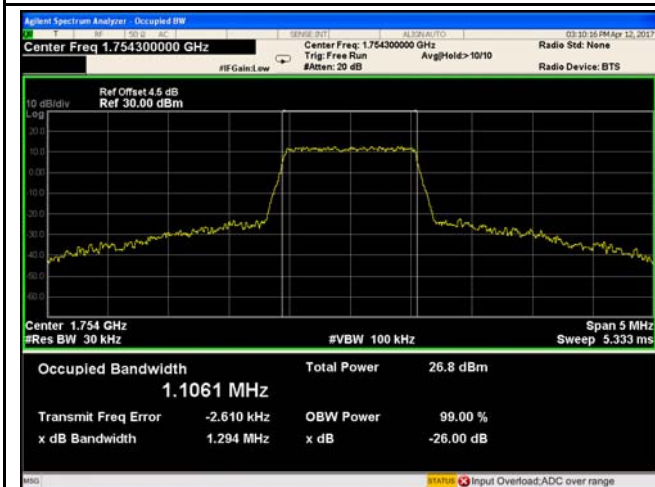

LTE band IV - High CH QPSK-1.4

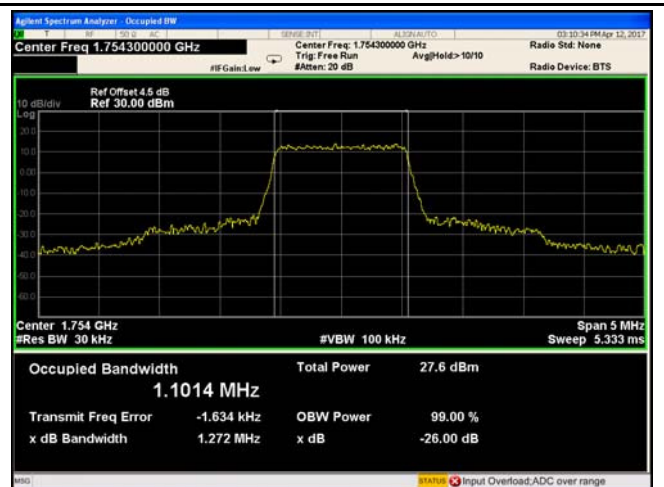

LTE band IV - High CH 16QAM-1.4



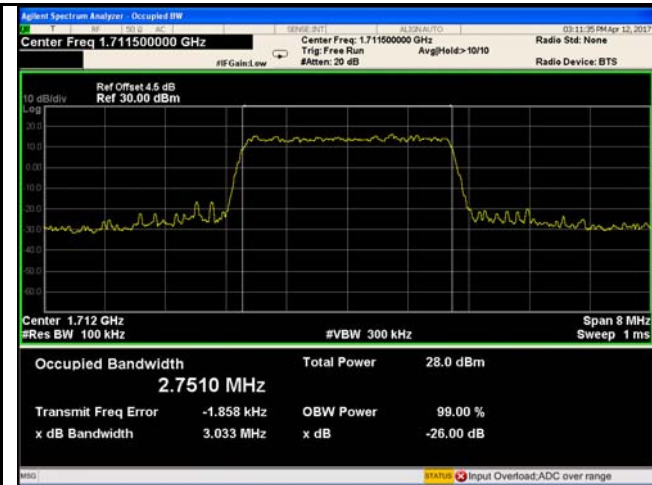

LTE band IV - Low CH QPSK-3

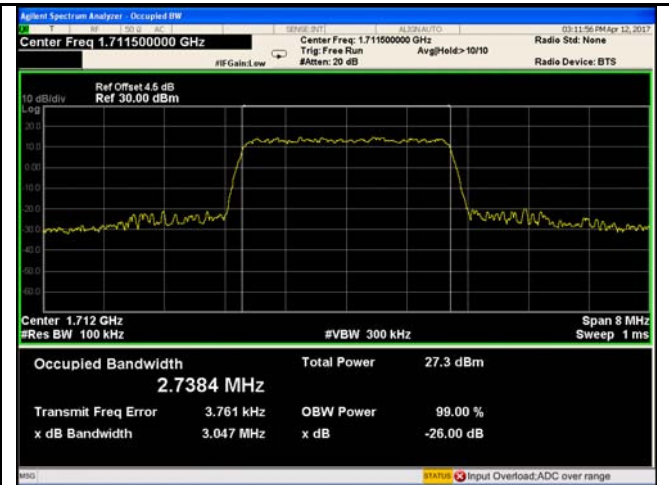

LTE band IV - Low CH 16QAM-3

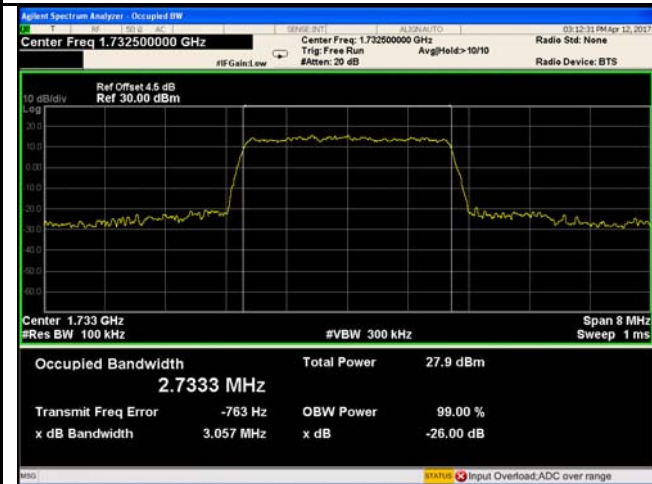

LTE band IV - Middle CH QPSK-3

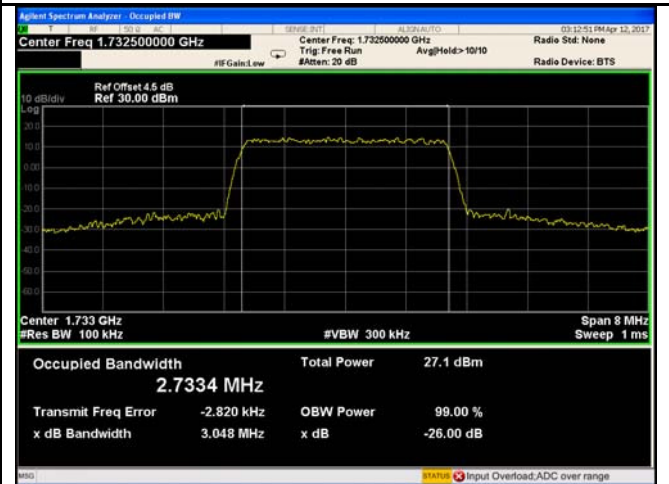

LTE band IV - Middle CH 16QAM-3

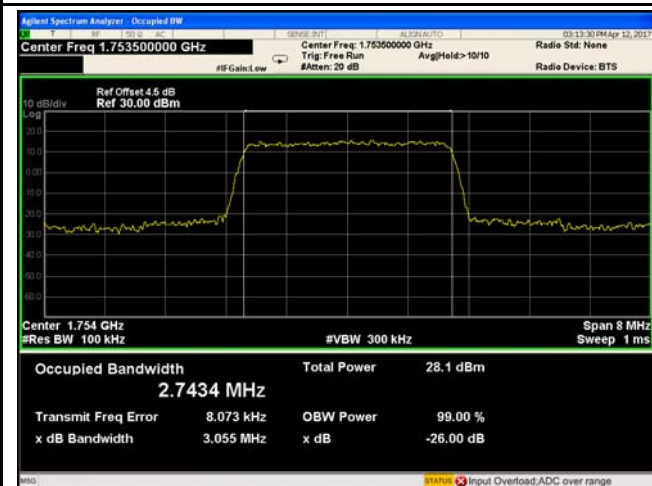

LTE band IV - High CH QPSK-3

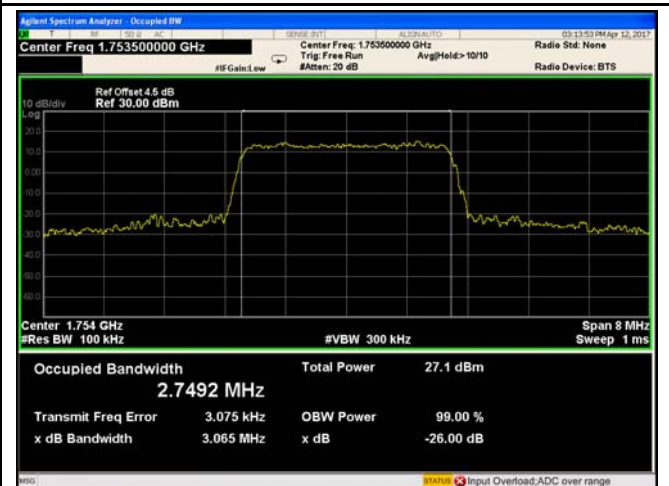

LTE band IV - High CH 16QAM-3

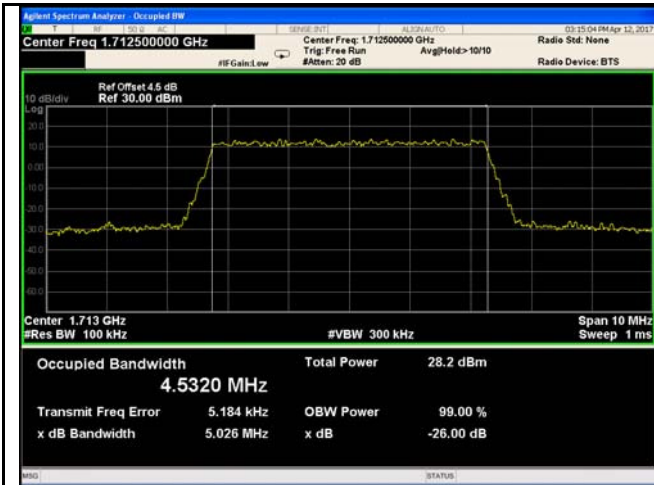

LTE band IV - Low CH QPSK-5

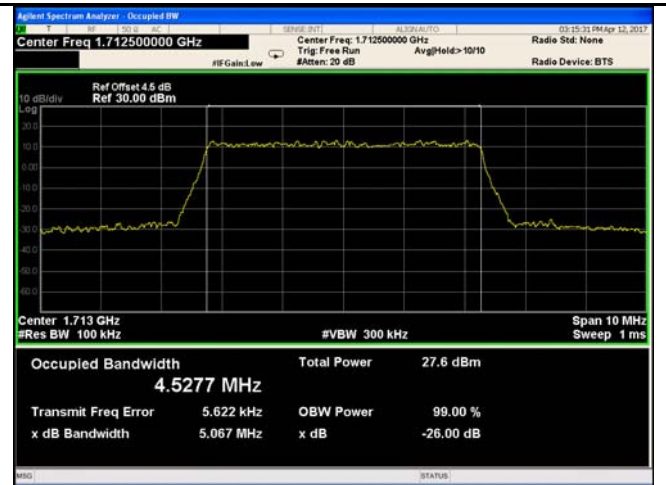

LTE band IV - Low CH 16QAM-5

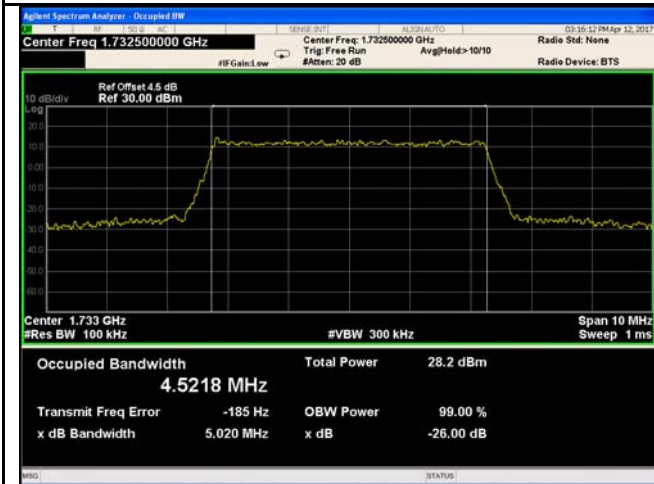

LTE band IV - Middle CH QPSK-5

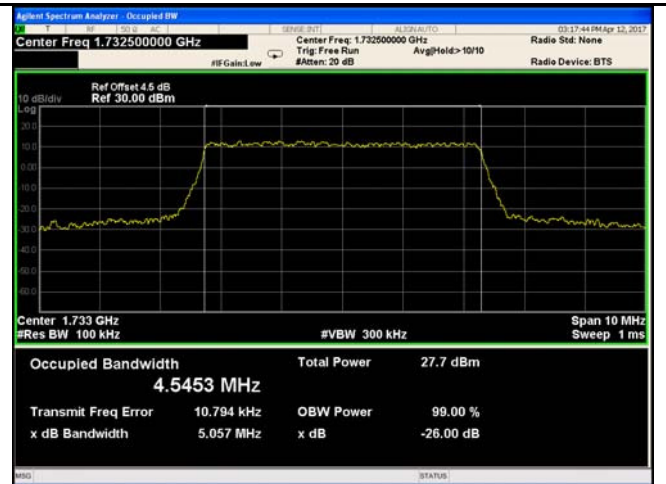

LTE band IV - Middle CH 16QAM-5

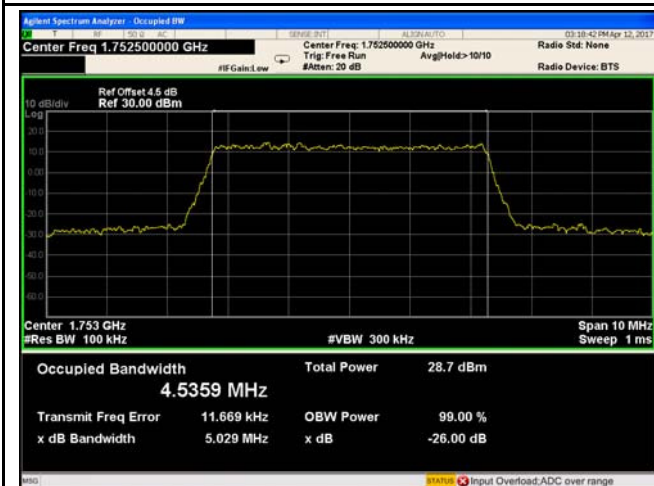

LTE band IV - High CH QPSK-5

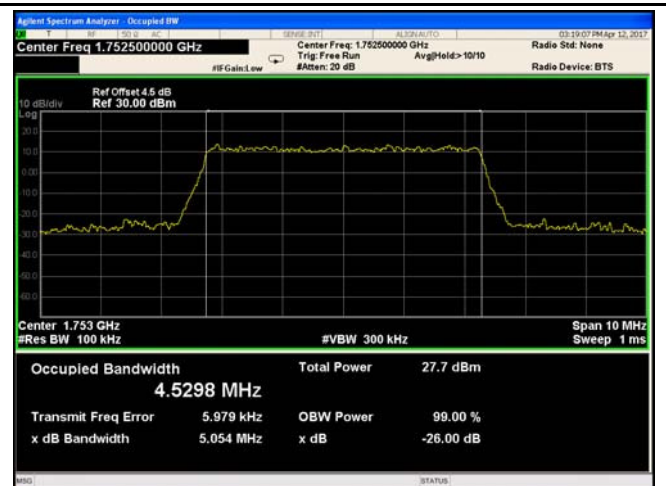

LTE band IV - High CH 16QAM-5

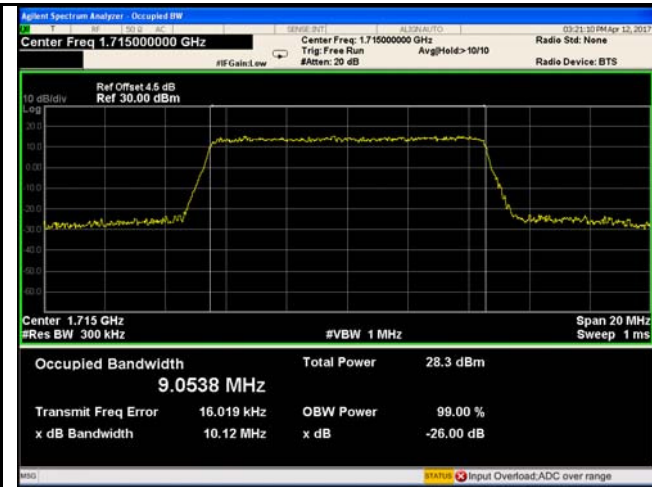

LTE band IV - Low CH QPSK-10



LTE band IV - Low CH 16QAM-10

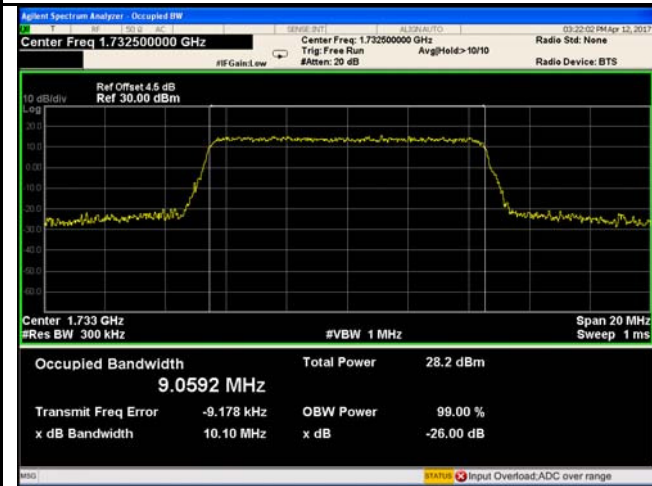

LTE band IV - Middle CH QPSK-10



LTE band IV - Middle CH 16QAM-10

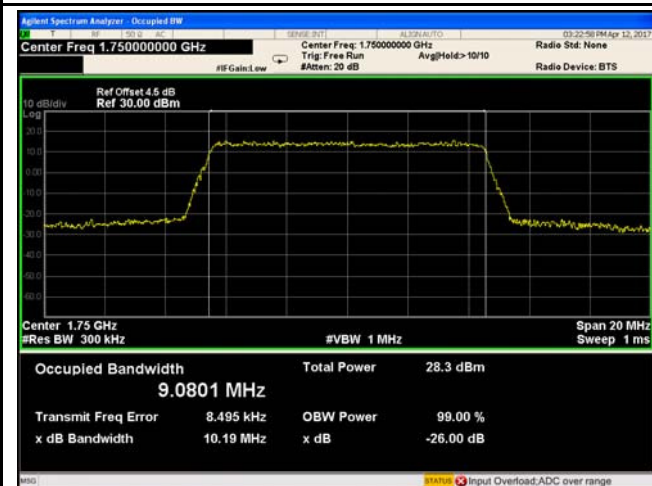

LTE band IV - High CH QPSK-10

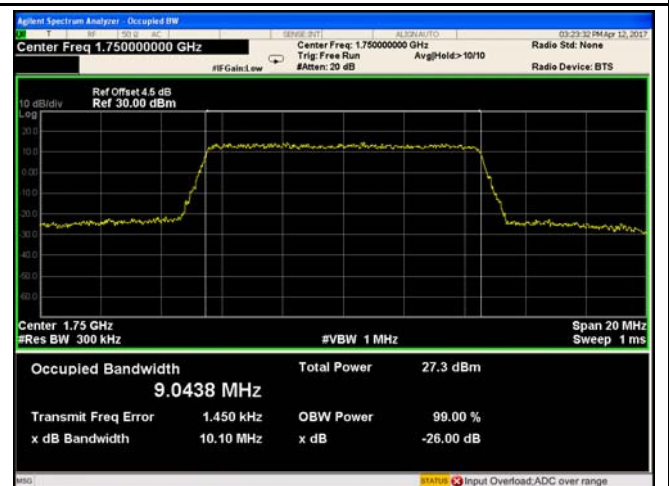

LTE band IV - High CH 16QAM-10

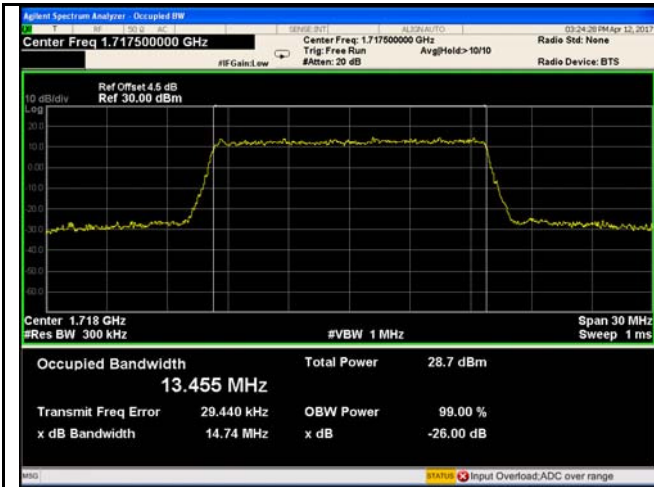

LTE band IV - Low CH QPSK-15



LTE band IV - Low CH 16QAM-15

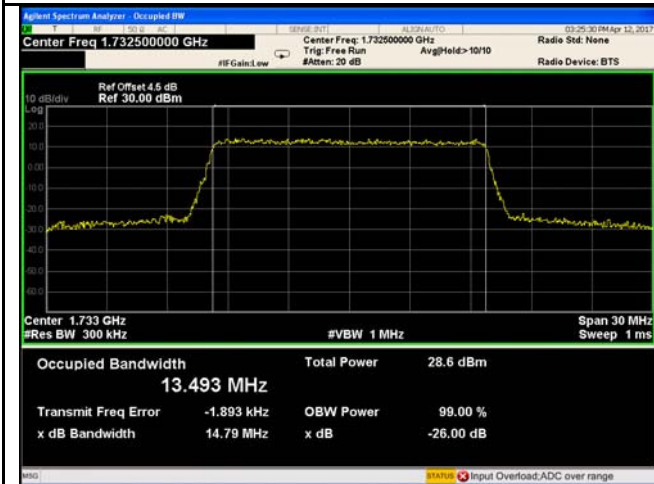

LTE band IV - Middle CH QPSK-15



LTE band IV - Middle CH 16QAM-15

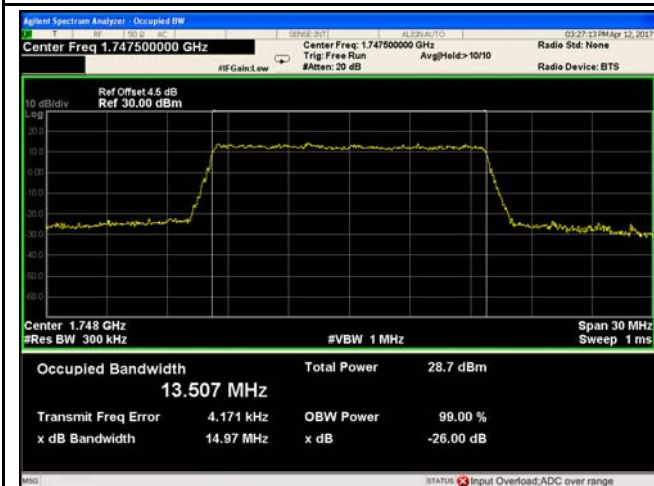

LTE band IV - High CH QPSK-15

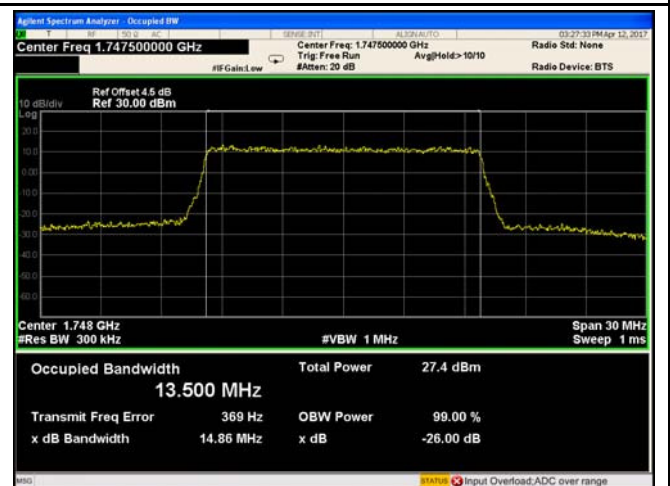

LTE band IV - High CH 16QAM-15

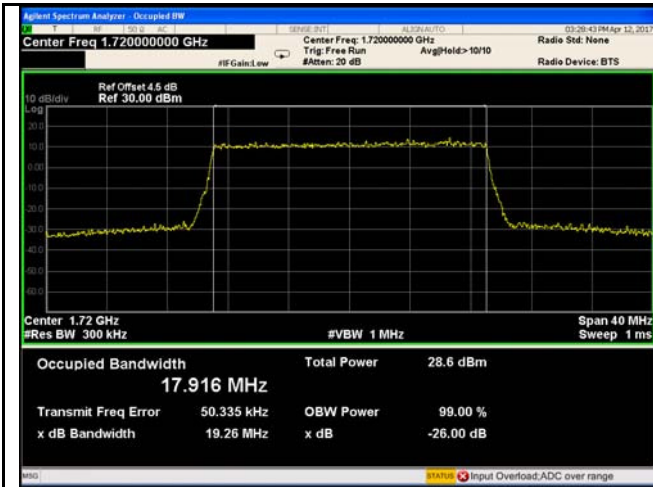

LTE band IV - Low CH QPSK-20

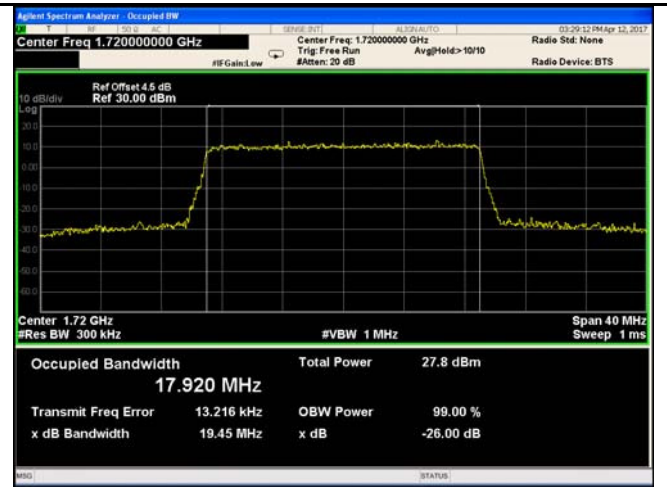

LTE band IV - Low CH 16QAM-20

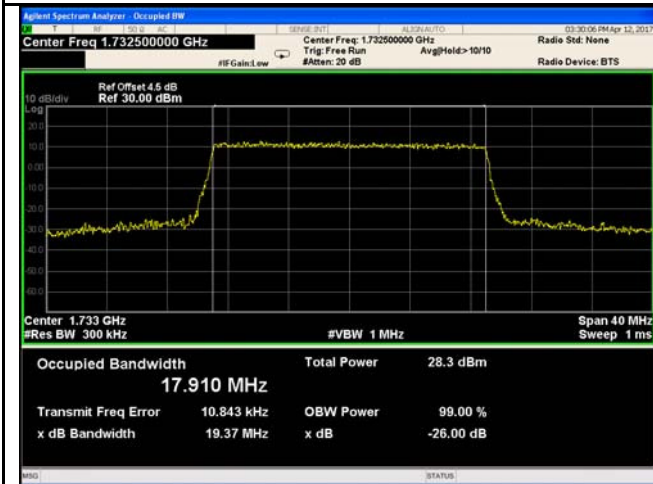

LTE band IV - Middle CH QPSK-20

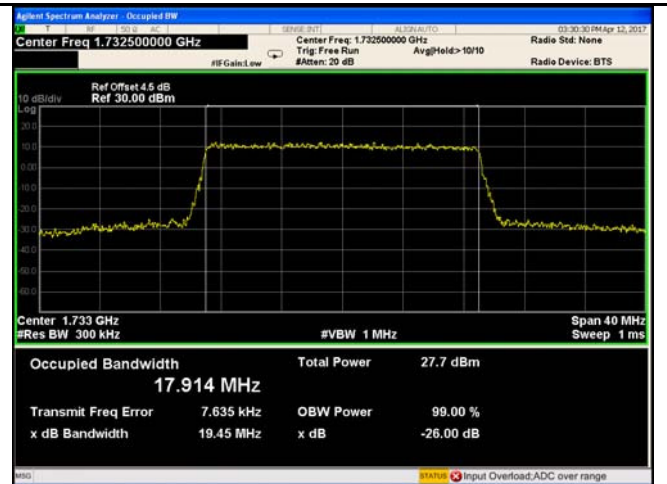

LTE band IV - Middle CH 16QAM-20

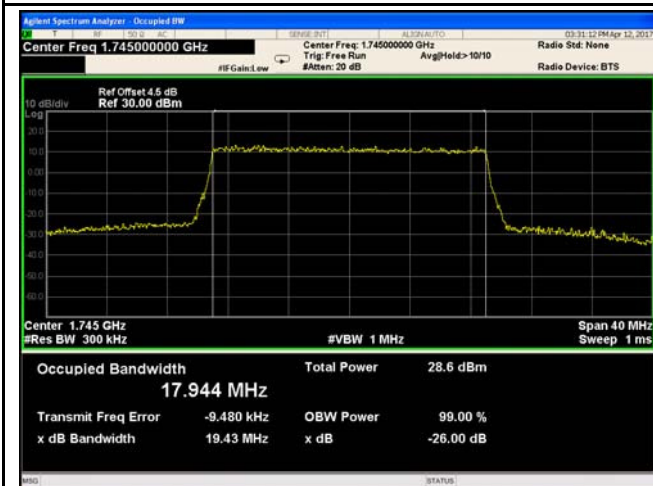

LTE band IV - High CH QPSK-20

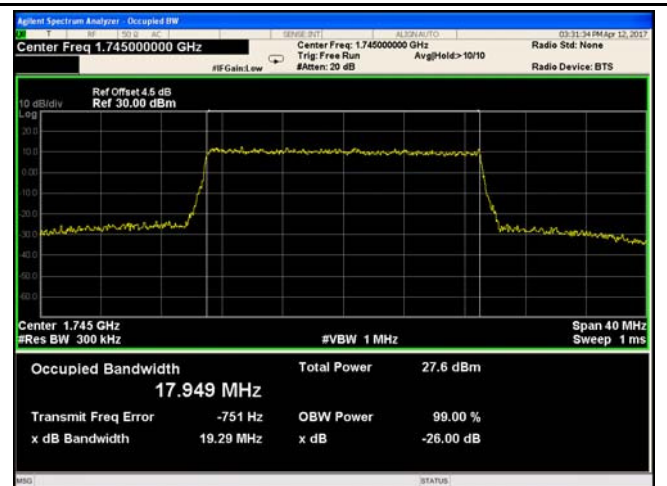

LTE band IV - High CH 16QAM-20



### LTE band VII (Part 27)

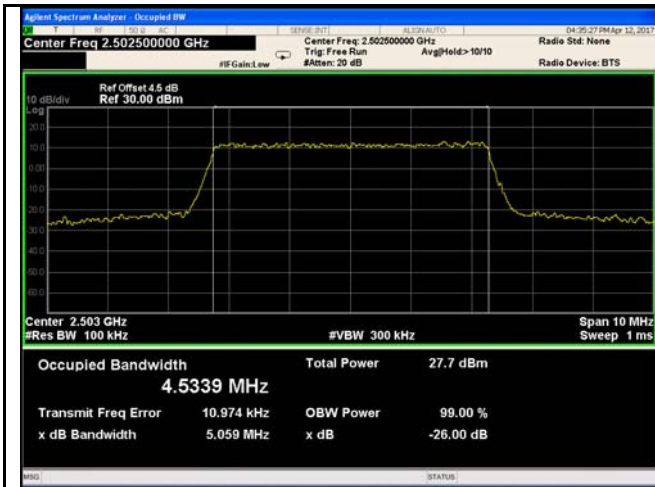

LTE band VII - Low CH QPSK-5

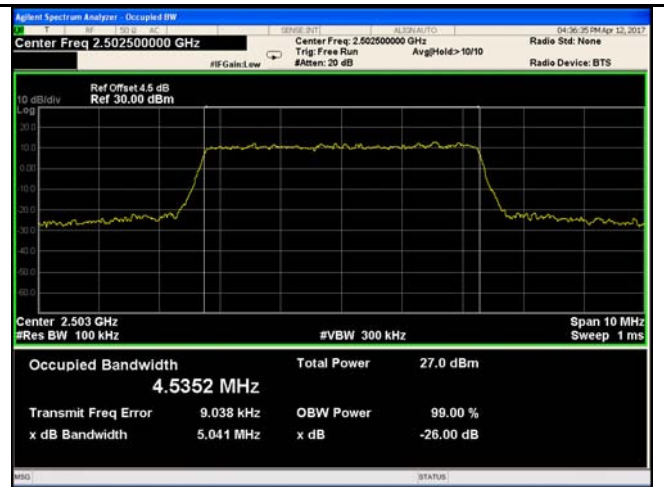

LTE band VII - Low CH 16QAM-5

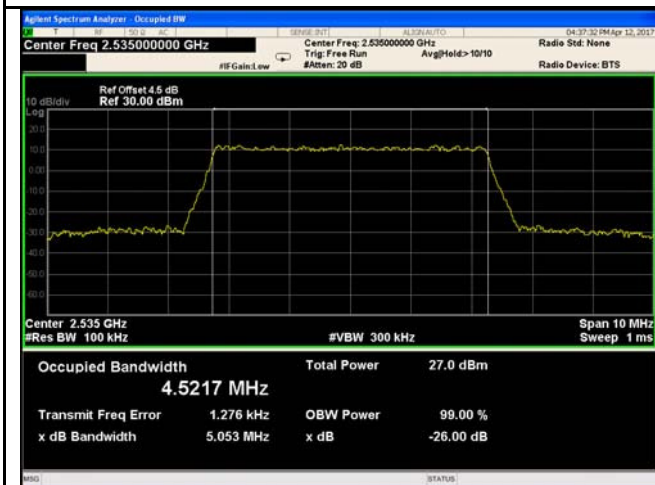

LTE band VII - Middle CH QPSK-5

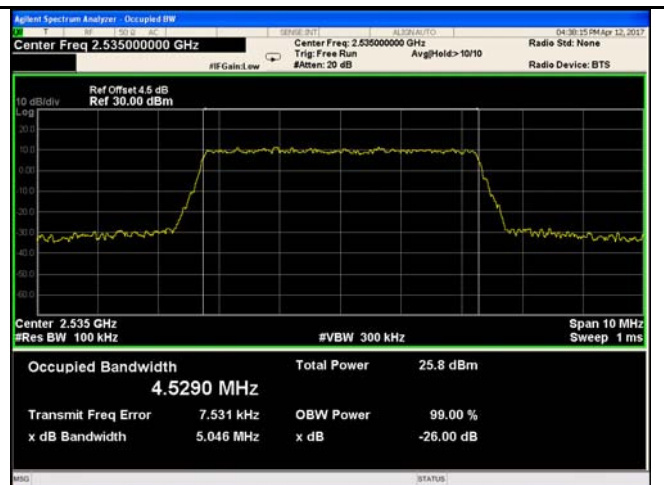

LTE band VII - Middle CH 16QAM-5

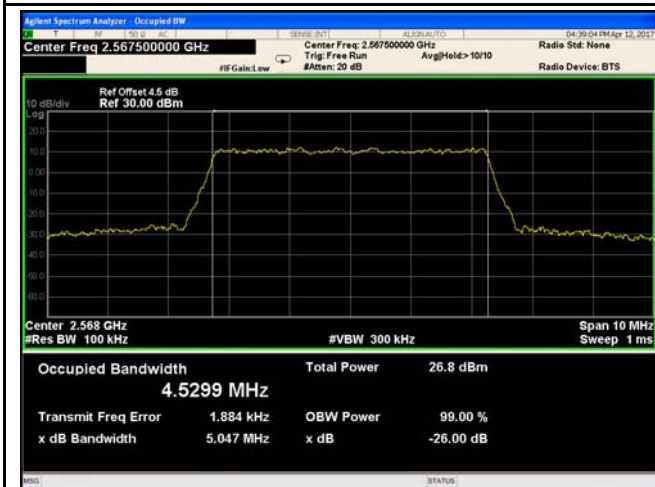

LTE band VII - High CH QPSK-5

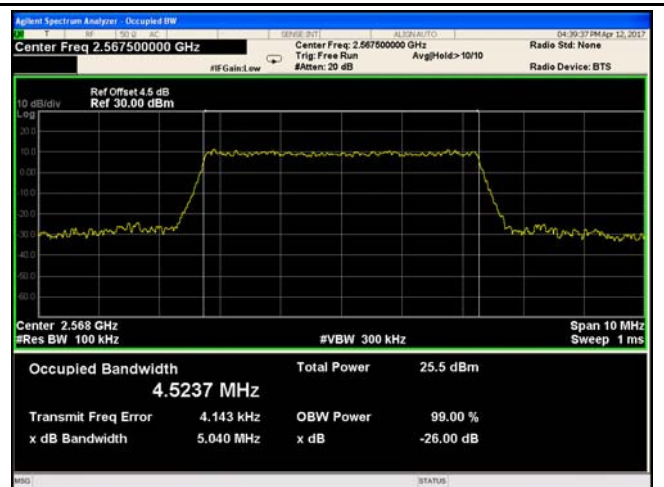

LTE band VII - High CH 16QAM-5

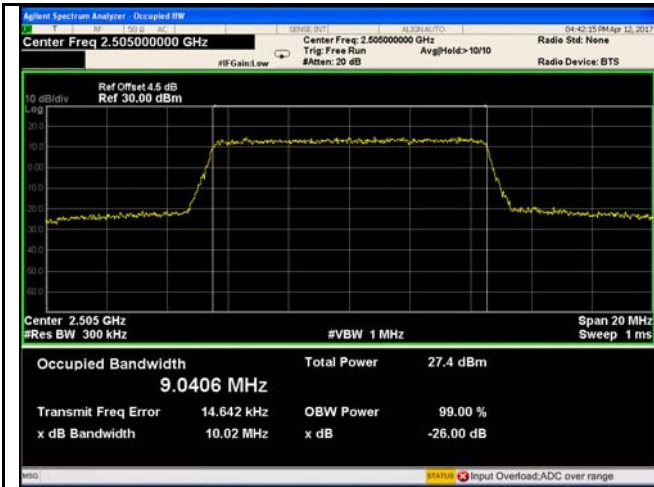

LTE band VII - Low CH QPSK-10

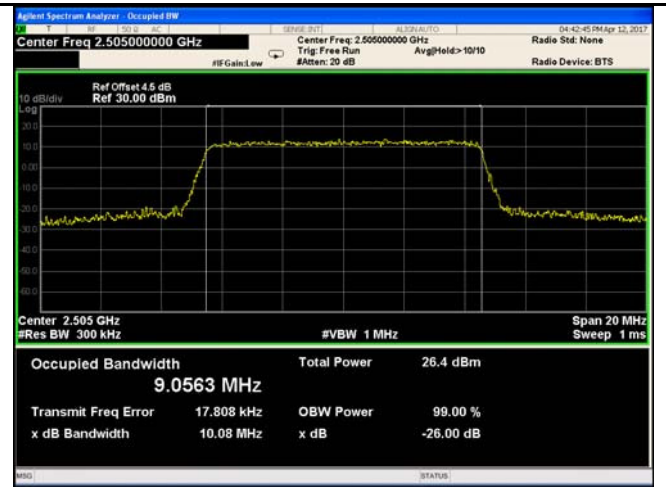

LTE band VII - Low CH 16QAM-10

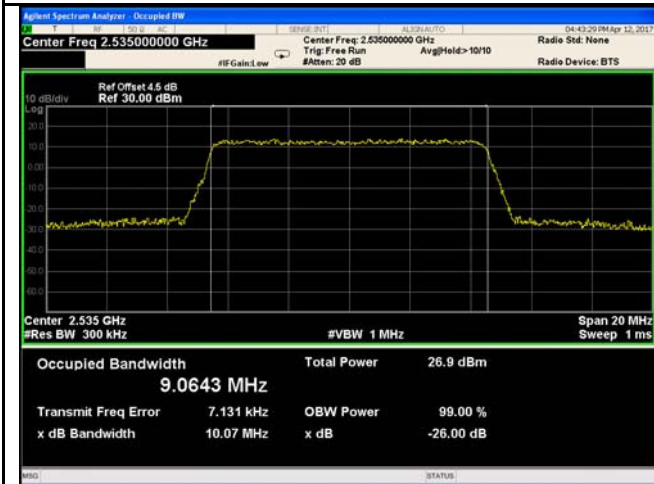

LTE band VII - Middle CH QPSK-10

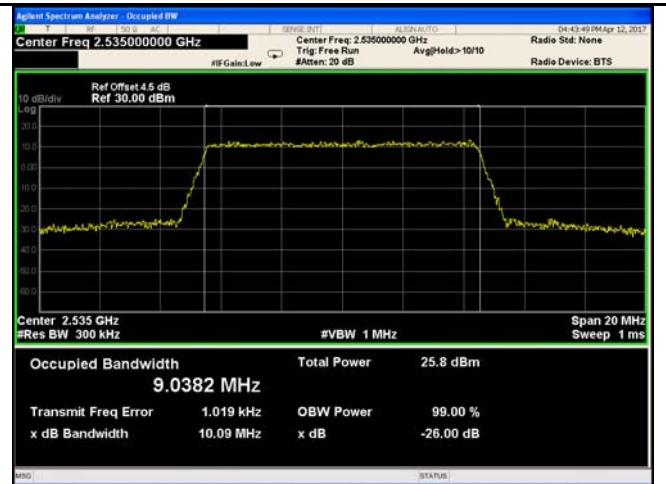

LTE band VII - Middle CH 16QAM-10

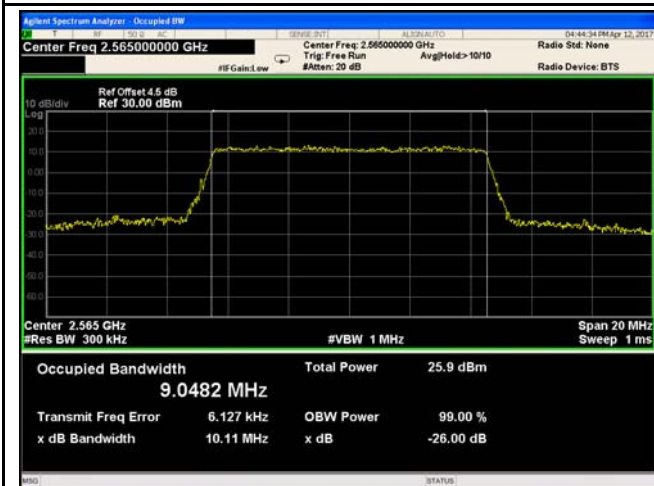

LTE band VII - High CH QPSK-10

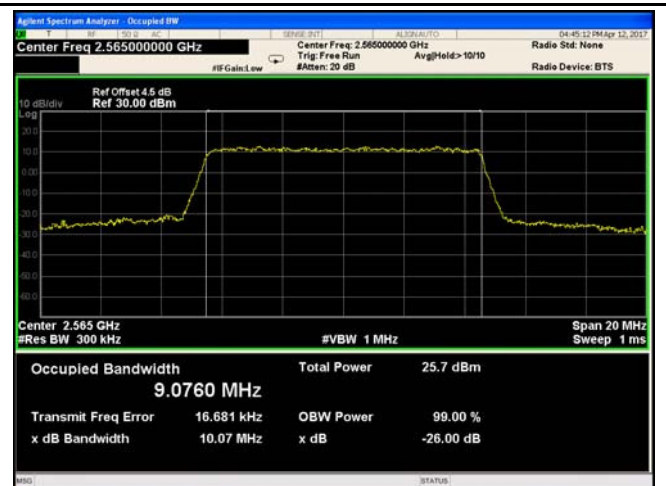

LTE band VII - High CH 16QAM-10

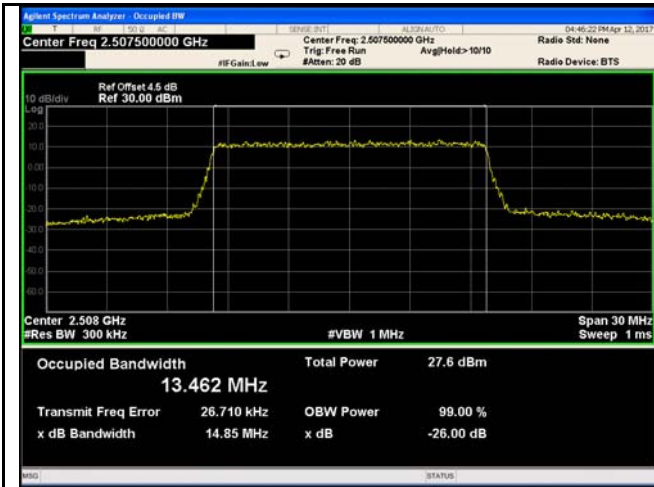

LTE band VII - Low CH QPSK-15

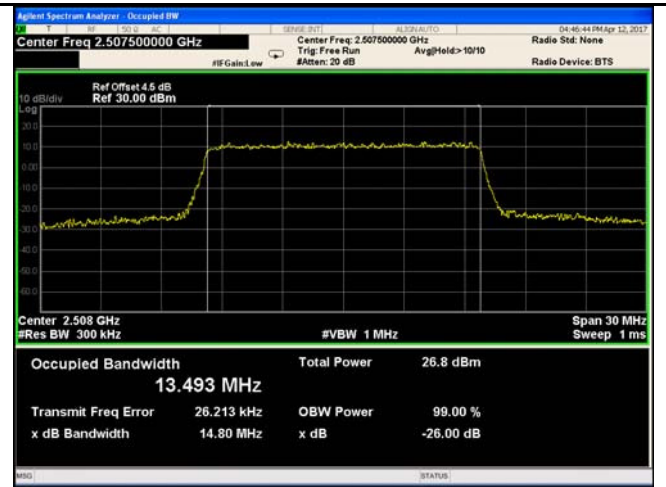

LTE band VII - Low CH 16QAM-15

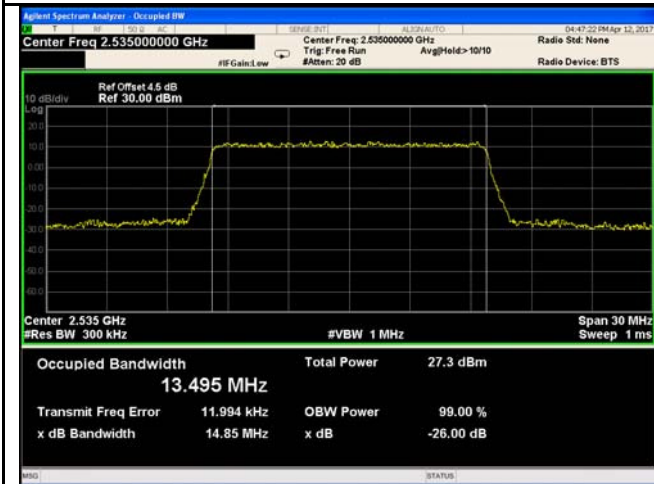

LTE band VII - Middle CH QPSK-15

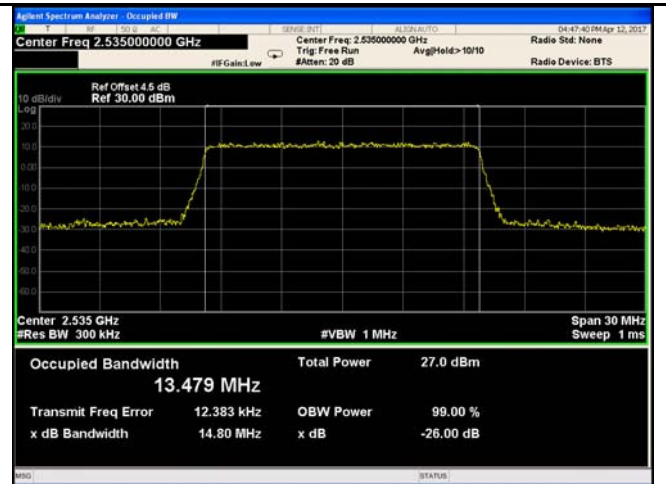

LTE band VII - Middle CH 16QAM-15

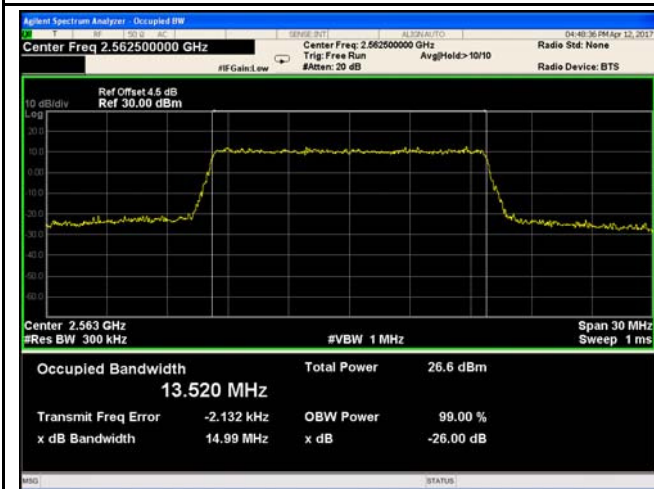

LTE band VII - High CH QPSK-15



LTE band VII - High CH 16QAM-15



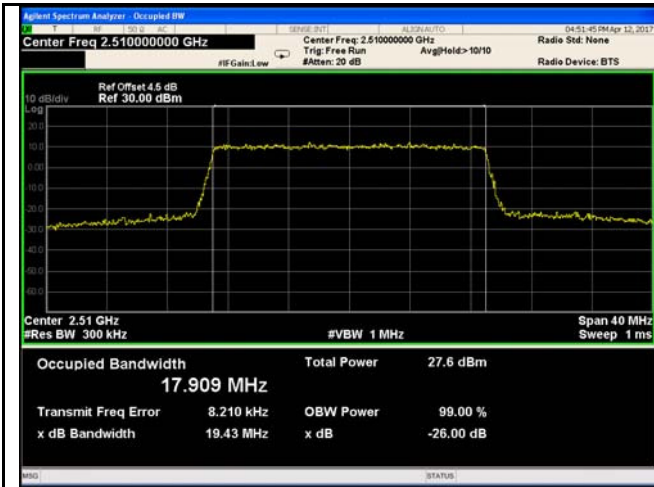

LTE band VII - Low CH QPSK-20



LTE band VII - Low CH 16QAM-20

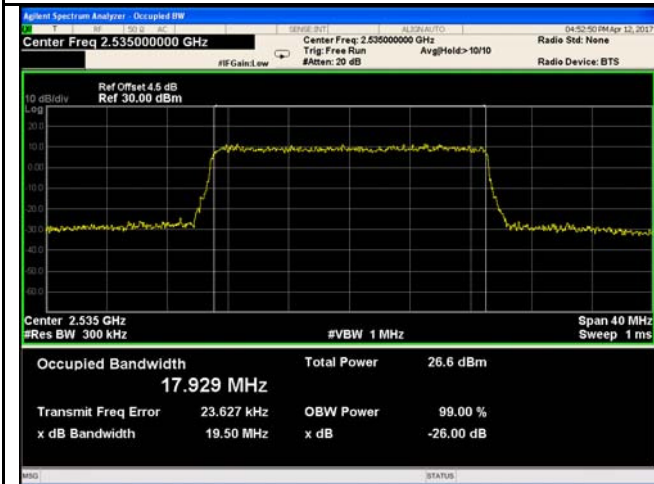

LTE band VII - Middle CH QPSK-20

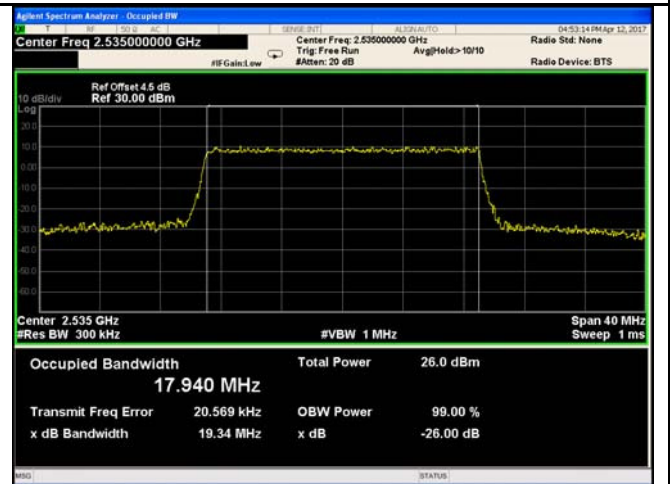

LTE band VII - Middle CH 16QAM-20

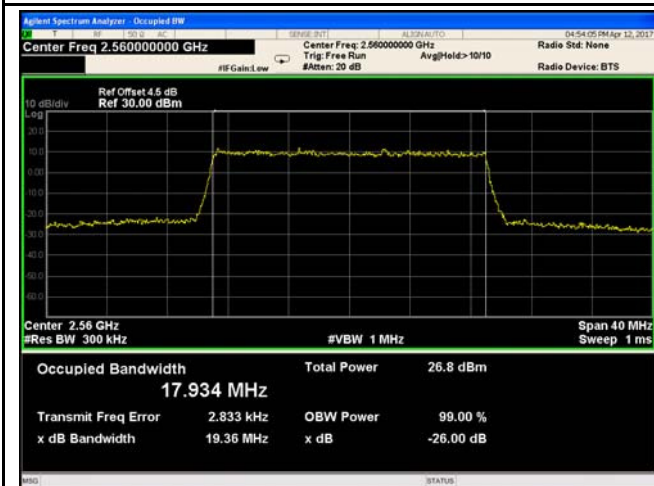

LTE band VII - High CH QPSK-20

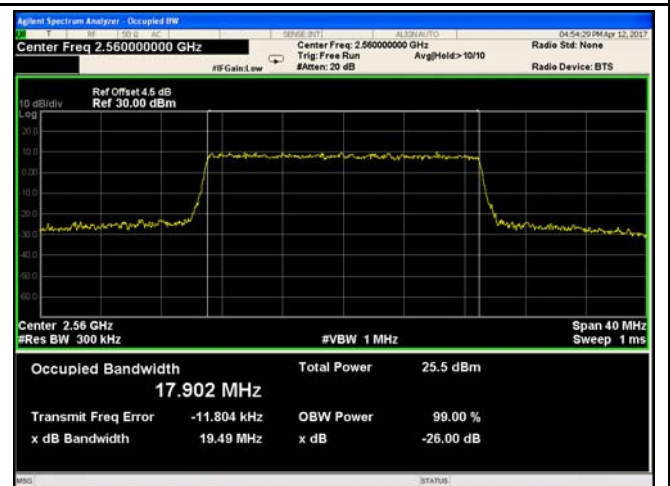

LTE band VII - High CH 16QAM-20

## 6.5 Spurious Emissions at Antenna Terminals

Temperature	24°C
Relative Humidity	55%
Atmospheric Pressure	1013mbar
Test date :	April 12, 2017
Tested By :	Loren Luo

### Requirement(s):

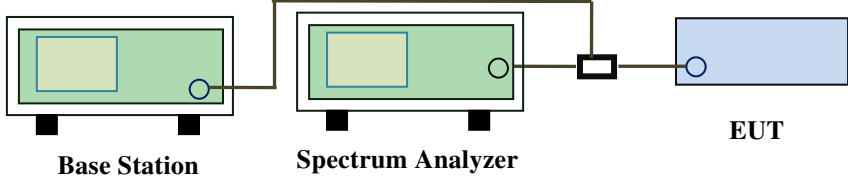
Spec	Item	Requirement	Applicable
§2.1051, §22.917(a)& §24.238(a) § 27.53(h)	a)	The power of any emission outside of the authorized operating frequency ranges must be lower than the transmitter power (P) by a factor of at least $43 + 10 \log(P)$ dB	<input checked="" type="checkbox"/>
Test Setup	 <p>The diagram shows a Base Station (green box) connected to a Spectrum Analyzer (green box) and an EUT (blue box) via a power divider (black box). The Base Station and Spectrum Analyzer are connected to the power divider, which then splits the signal to the EUT.</p>		
Test Procedure	<ul style="list-style-type: none"> <li>- The EUT was connected to Spectrum Analyzer and Base Station via power divider.</li> <li>- The Band Edges of low and high channels for the highest RF powers were measured.</li> <li>- Setting RBW as roughly BW/100.</li> </ul>		
Remark			
Result	<input checked="" type="checkbox"/> Pass <input type="checkbox"/> Fail		

Test Data     Yes       N/A  
 Test Plot     Yes (See below)       N/A

Test Plots 30MHz-5GHz  
LTE band II (Part 24E)

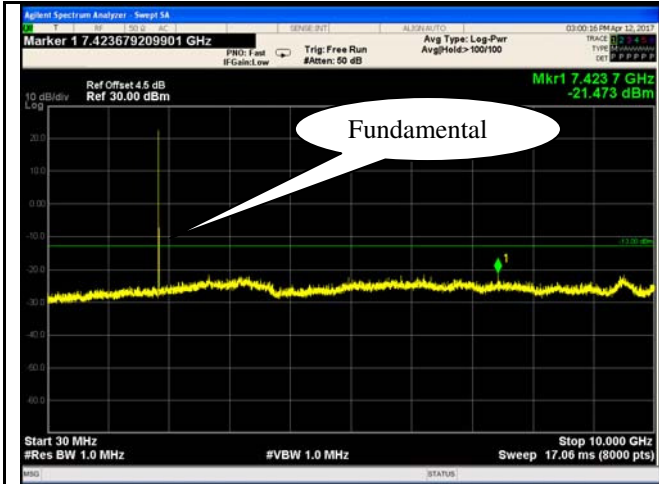

LTE band II - Low Channel-1



LTE band II - Low Channel-2

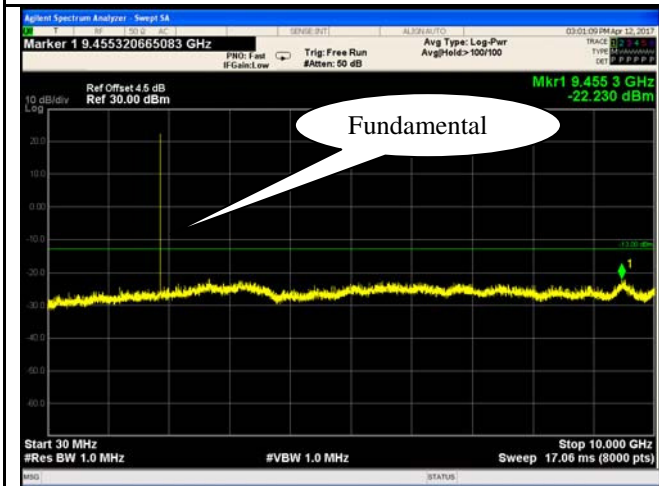

LTE band II Middle Channel-1

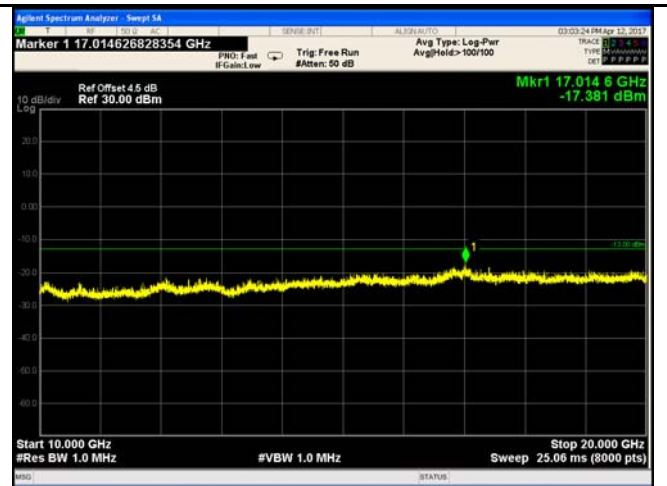

LTE band II Middle Channel-2

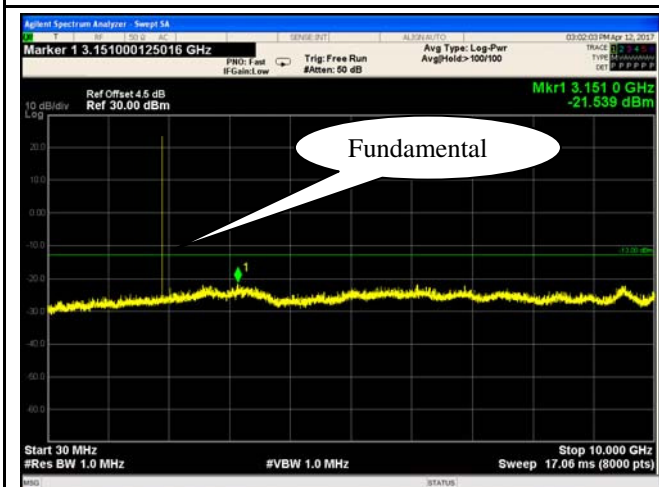

LTE band II - High Channel-1

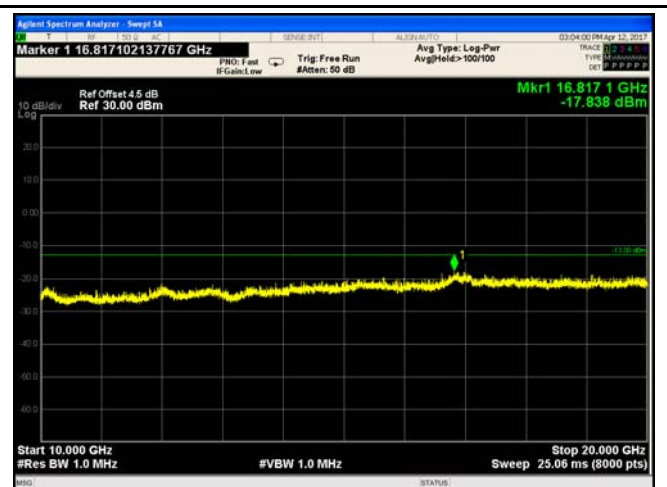

LTE band II - High Channel-2

### LTE band IV (Part27) result

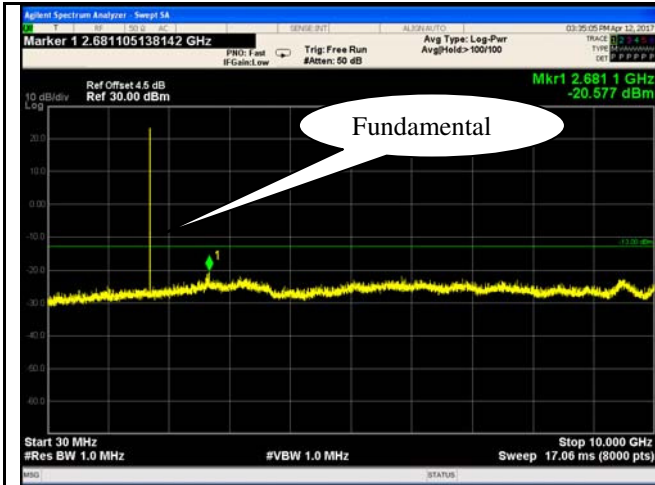

LTE band IV - Low Channel-1

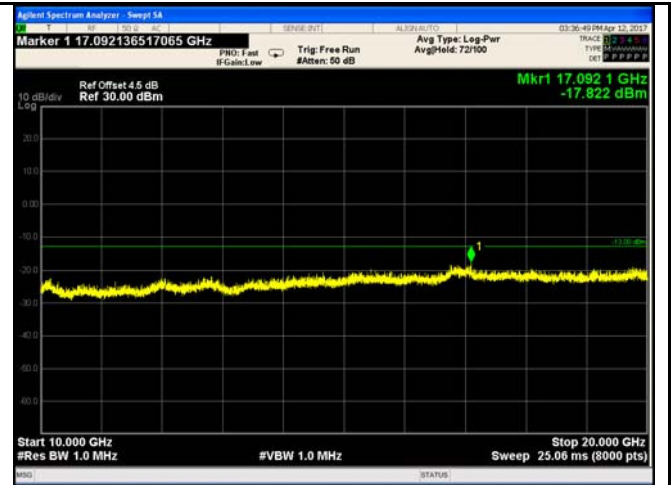

LTE band IV - Low Channel-2

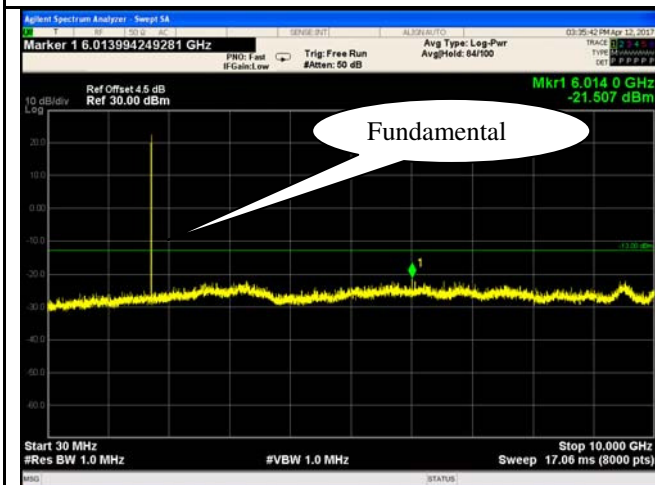

LTE band IV - Middle Channel-1

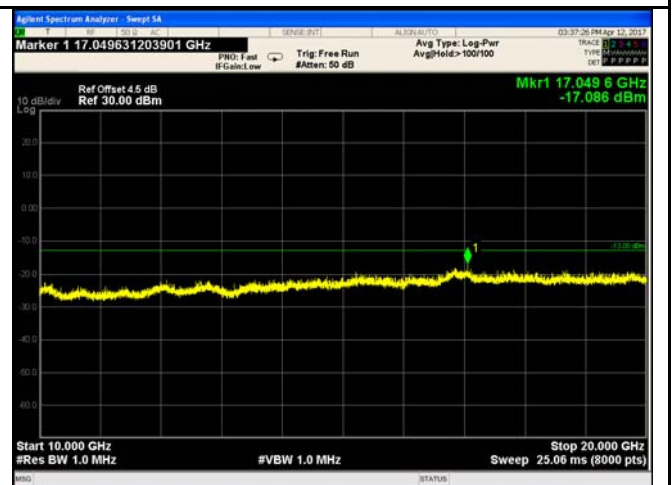

LTE band IV - Middle Channel-2

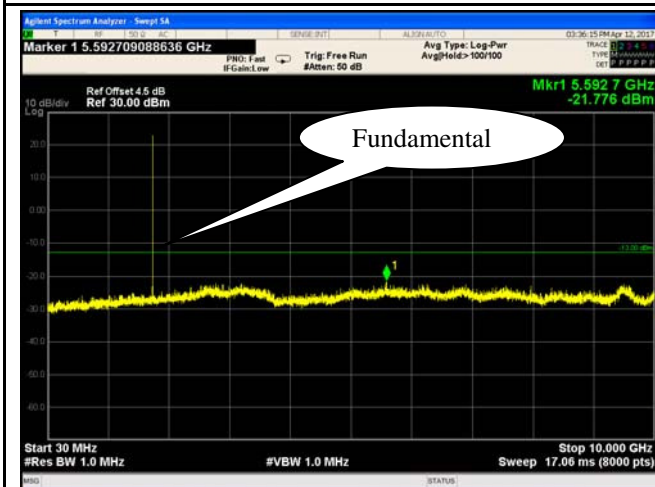

LTE band IV - High Channel-1

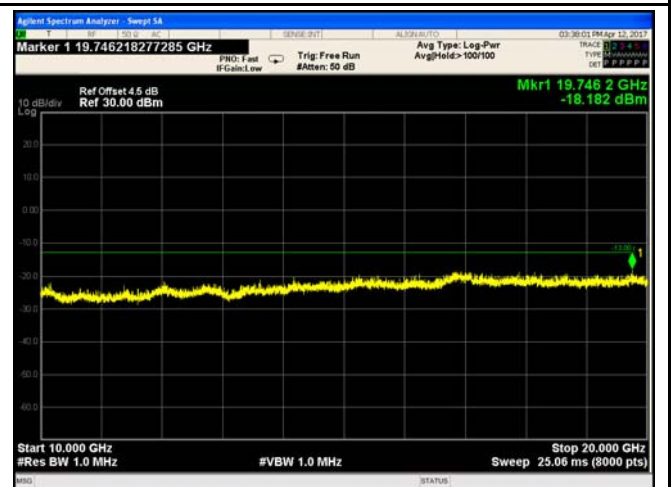

LTE band IV - High Channel-2

### LTE band VII (Part 27)

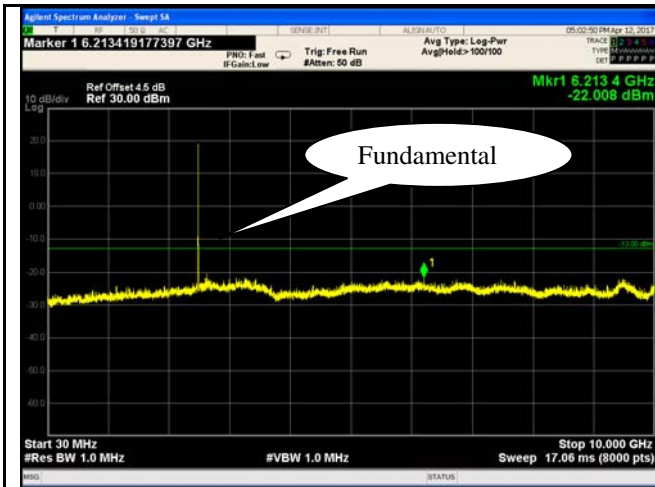

LTE band VII - Low Channel-1

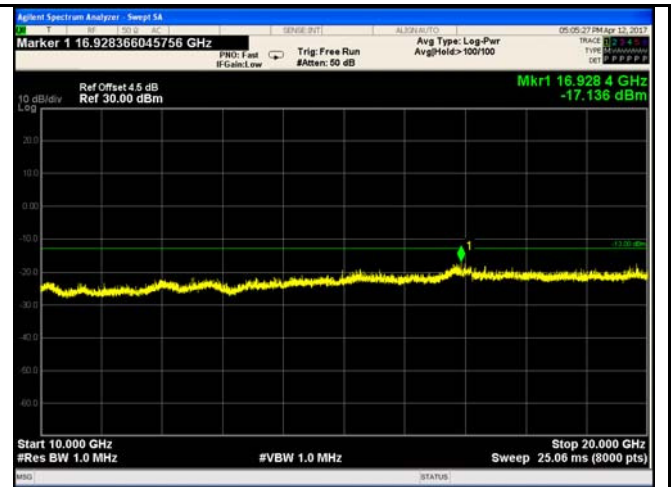

LTE band VII - Low Channel-2

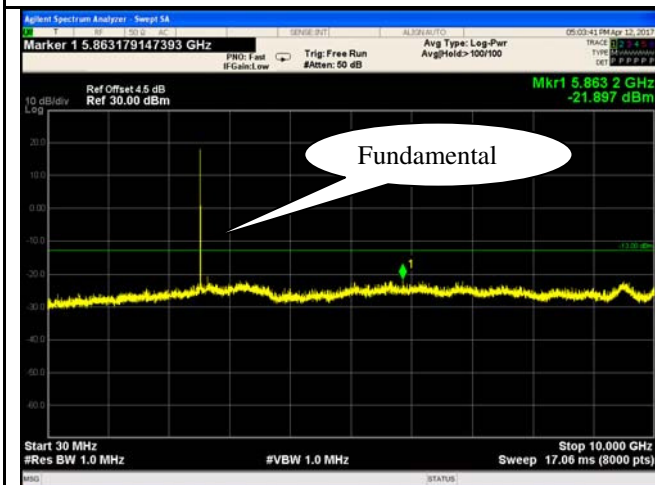

LTE band VII - Middle Channel-1

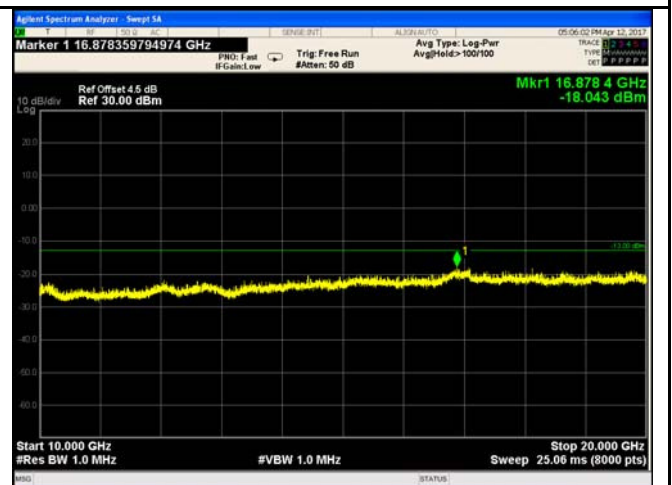

LTE band VII - Middle Channel-2

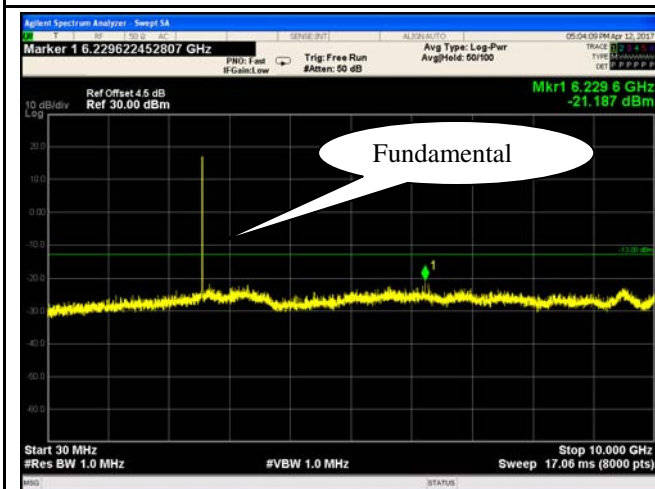

LTE band VII - High Channel-1

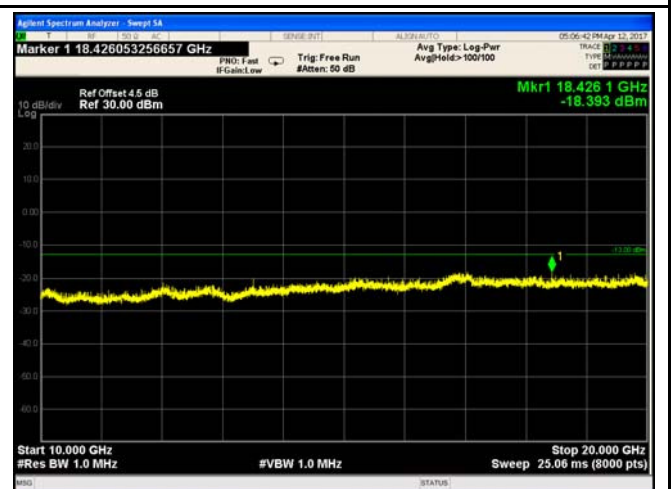

LTE band VII - High Channel-2

## 6.6 Spurious Radiated Emissions

Temperature	22°C
Relative Humidity	53%
Atmospheric Pressure	1010mbar
Test date :	April 13, 2017
Tested By :	Loren Luo

### Requirement(s):

Spec	Item	Requirement	Applicable
§2.1053, §22.917 & §24.238 § 27.53(h)	a)	The power of any emission outside of the authorized operating frequency ranges must be attenuated below the transmitter power (P) by a factor of at least $43 + 10 \log (P)$ dB. The spectrum is scanned from 30 MHz up to a frequency including its 10th harmonic.	<input checked="" type="checkbox"/>

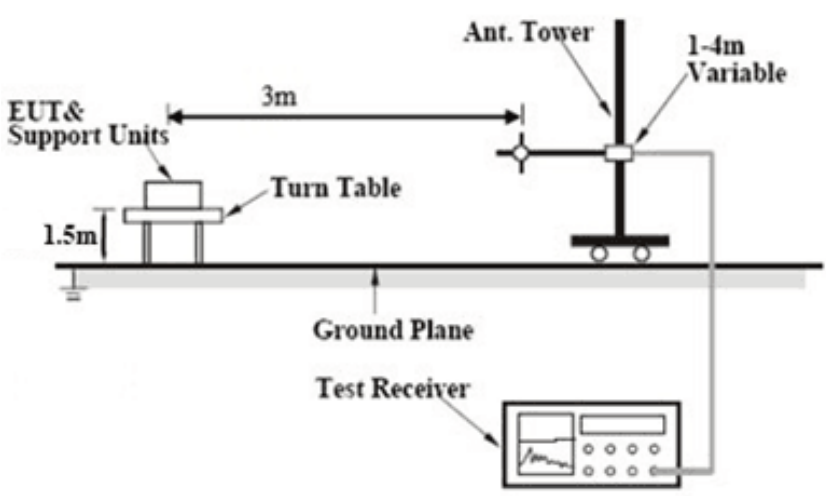
Test setup	
------------	--

Test Procedure	<ol style="list-style-type: none"> <li>The transmitter was placed on a wooden turntable, and it was transmitting into a non-radiating load which was also placed on the turntable.</li> <li>The measurement antenna was placed at a distance of 3 meters from the EUT. During the tests, the antenna height and polarization as well as EUT azimuth were varied in order to identify the maximum level of emissions from the EUT. The test was performed by placing the EUT on 3-orthogonal axis.</li> <li>Remove the EUT and replace it with substitution antenna. A signal generator was connected to the substitution antenna by a non-radiating cable. The absolute levels of the spurious emissions were measured by the substitution. Sample Calculation: EUT Field Strength = Raw Amplitude (dBµV/m) – Amplifier Gain (dB) + Antenna</li> </ol>
----------------	--



Test Report	17070226-FCC-R5
Page	67 of 112

	Factor (dB) + Cable Loss (dB) + Filter Attenuation (dB, if used)
Remark	
Result	<input checked="" type="checkbox"/> Pass <input type="checkbox"/> Fail

Test Data  Yes  N/A

Test Plot  Yes (See below)  N/A

## LTE band II (Part 24E) result

### Low channel

Frequency (MHz)	Substituted level (dBm)	Polarity (H/V)	Antenna Gain Correction (dB)	Cable Loss (dB)	Corrected Reading (dBm)	Limit (dBm)	Margin (dB)
3720	-46.31	V	10.25	2.73	-38.79	-13	-25.79
3720	-46.89	H	10.25	2.73	-39.37	-13	-26.37
50.8	-45.26	V	-4.2	0.11	-49.57	-13	-36.57
204.5	-48.73	H	4.6	0.18	-44.31	-13	-31.31

### Middle channel

Frequency (MHz)	Substituted level (dBm)	Polarity (H/V)	Antenna Gain Correction (dB)	Cable Loss (dB)	Corrected Reading (dBm)	Limit (dBm)	Margin (dB)
3760	-46.35	V	10.25	2.73	-38.83	-13	-25.83
3760	-46.98	H	10.25	2.73	-39.46	-13	-26.46
50.8	-45.03	V	-4.2	0.11	-49.34	-13	-36.34
204.5	-48.16	H	4.6	0.18	-43.74	-13	-30.74

### High channel

Frequency (MHz)	Substituted level (dBm)	Polarity (H/V)	Antenna Gain Correction (dB)	Cable Loss (dB)	Corrected Reading (dBm)	Limit (dBm)	Margin (dB)
3800	-46.02	V	10.36	2.73	-38.39	-13	-25.39
3800	-46.83	H	10.36	2.73	-39.2	-13	-26.2
50.8	-45.07	V	-4.2	0.11	-49.38	-13	-36.38
204.5	-46.89	H	4.6	0.18	-42.47	-13	-29.47

#### Note:

1, The testing has been conformed to  $10 \times 1907.5 \text{ MHz} = 19,075 \text{ MHz}$

2, All other emissions more than 30 dB below the limit

3, X-Axis, Y-Axis and -Axis were investigated. The results above show only the worst case.



## LTE band IV(Part27) result

### Low channel

Frequency (MHz)	Substituted level (dBm)	Polarity (H/V)	Antenna Gain Correction (dB)	Cable Loss (dB)	Corrected Reading (dBm)	Limit (dBm)	Margin (dB)
3440	-46.18	V	10.06	2.52	-38.64	-13	-25.64
3440	-47.32	H	10.06	2.52	-39.78	-13	-26.78
50.8	-45.53	V	-4.2	0.11	-49.84	-13	-36.84
204.5	-48.61	H	4.6	0.18	-44.19	-13	-31.19

### Middle channel

Frequency (MHz)	Substituted level (dBm)	Polarity (H/V)	Antenna Gain Correction (dB)	Cable Loss (dB)	Corrected Reading (dBm)	Limit (dBm)	Margin (dB)
3465	-46.37	V	10.09	2.52	-38.8	-13	-25.8
3465	-46.95	H	10.09	2.52	-39.38	-13	-26.38
50.8	-46.55	V	-4.2	0.11	-50.86	-13	-37.86
204.5	-49.34	H	4.6	0.18	-44.92	-13	-31.92

### High channel

Frequency (MHz)	Substituted level (dBm)	Polarity (H/V)	Antenna Gain Correction (dB)	Cable Loss (dB)	Corrected Reading (dBm)	Limit (dBm)	Margin (dB)
3490	-45.99	V	10.09	2.52	-38.42	-13	-25.42
3490	-47.15	H	10.09	2.52	-39.58	-13	-26.58
50.8	-46.33	V	-4.2	0.11	-50.64	-13	-37.64
204.5	-48.86	H	4.6	0.18	-44.44	-13	-31.44

**Note:**

- 1, The testing has been conformed to  $10 \times 1752.5\text{MHz} = 17,525\text{MHz}$
- 2, All other emissions more than 30 dB below the limit
- 3, X-Axis, Y-Axis and -Axis were investigated. The results above show only the worst case.

## LTE band VII(Part27) result

### Low channel

Frequency (MHz)	Substituted level (dBm)	Polarity (H/V)	Antenna Gain Correction (dB)	Cable Loss (dB)	Corrected Reading (dBm)	Limit (dBm)	Margin (dB)
5020	-48.22	V	10.29	0.98	-38.91	-13	-25.91
5020	-47.96	H	10.29	0.98	-38.65	-13	-25.65
50.8	-46.38	V	-4.2	0.11	-50.69	-13	-37.69
204.5	-48.24	H	4.6	0.18	-43.82	-13	-30.82

### Middle channel

Frequency (MHz)	Substituted level (dBm)	Polarity (H/V)	Antenna Gain Correction (dB)	Cable Loss (dB)	Corrected Reading (dBm)	Limit (dBm)	Margin (dB)
5070	-47.94	V	10.3	0.99	-38.63	-13	-25.63
5070	-48.11	H	10.3	0.99	-38.8	-13	-25.8
50.8	-45.83	V	-4.2	0.11	-50.14	-13	-37.14
204.5	-48.25	H	4.6	0.18	-43.83	-13	-30.83

### High channel

Frequency (MHz)	Substituted level (dBm)	Polarity (H/V)	Antenna Gain Correction (dB)	Cable Loss (dB)	Corrected Reading (dBm)	Limit (dBm)	Margin (dB)
5120	-48.21	V	10.32	1	-38.89	-13	-25.89
5120	-48.35	H	10.32	1	-39.03	-13	-26.03
50.8	-46.27	V	-4.2	0.11	-50.58	-13	-37.58
204.5	-47.3	H	4.6	0.18	-42.88	-13	-29.88

#### Note:

- 1, The testing has been conformed to  $10 \times 2567.5 \text{ MHz} = 25,675 \text{ MHz}$
- 2, All other emissions more than 30 dB below the limit
- 3, X-Axis, Y-Axis and -Axis were investigated. The results above show only the worst case.

## 6.7 Band Edge

Temperature	24°C
Relative Humidity	55%
Atmospheric Pressure	1013mbar
Test date :	April 12, 2017
Tested By :	Loren Luo

### Requirement(s):

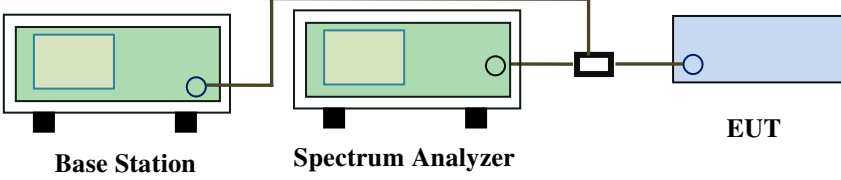
Spec	Item	Requirement	Applicable
§22.917(a) §24.238(a) § 27.53(h)	a)	The power of any emission outside of the authorized operating frequency ranges must be lower than the transmitter power (P) by a factor of at least $43 + 10 \log (P)$ dB.	<input checked="" type="checkbox"/>
Test setup	 <p>The diagram shows a Base Station (green box) connected to a Spectrum Analyzer (green box) and an EUT (blue box) via a power divider (black box). The Base Station and Spectrum Analyzer are connected to each other, and the Spectrum Analyzer is connected to the power divider, which then splits the signal to the EUT.</p>		
Procedure	<ul style="list-style-type: none"> <li>- The EUT was connected to Spectrum Analyzer and Base Station via power divider.</li> <li>- The Band Edges of low and high channels for the highest RF powers were measured. Setting RBW as roughly BW/100.</li> </ul>		
Remark			
Result	<input checked="" type="checkbox"/> Pass <input type="checkbox"/> Fail		

Test Data     Yes       N/A

Test Plot     Yes (See below)       N/A

**LTE band II (Part 24E) result**

BW(MHz)	Channel	Frequency (MHz)	Mode	Emission (dBm)	Limit (dBm)
1.4	18607	1850	QPSK	-28.434	-13
			16QAM	-28.014	-13
1.4	18900	1910	QPSK	-28.560	-13
			16QAM	-27.805	-13
3	18615	1850	QPSK	-21.546	-13
			16QAM	-21.225	-13
3	19185	1910	QPSK	-23.845	-13
			16QAM	-23.811	-13
5	18625	1850	QPSK	-18.563	-13
			16QAM	-19.671	-13
5	19175	1910	QPSK	-20.352	-13
			16QAM	-21.499	-13
10	18650	1850	QPSK	-20.643	-13
			16QAM	-18.451	-13
10	19150	1910	QPSK	-19.649	-13
			16QAM	-20.480	-13
15	18675	1850	QPSK	-23.606	-13
			16QAM	-24.573	-13
15	19125	1910	QPSK	-24.593	-13
			16QAM	-23.060	-13
20	18700	1848	QPSK	-23.909	-13
			16QAM	-24.030	-13
20	19100	1911	QPSK	-27.482	-13
			16QAM	-27.820	-13

### LTE band IV (Part 27) result

BW(MHz)	Channel	Frequency (MHz)	Mode	Emission (dBm)	Limit (dBm)
1.4	19957	1710	QPSK	-28.884	-13
			16QAM	-28.831	-13
1.4	20393	1755	QPSK	-27.282	-13
			16QAM	-26.584	-13
3	19965	1710	QPSK	-20.983	-13
			16QAM	-21.628	-13
3	20385	1755	QPSK	-21.170	-13
			16QAM	-20.853	-13
5	19975	1710	QPSK	-17.819	-13
			16QAM	-18.028	-13
5	20375	1755	QPSK	-19.264	-13
			16QAM	-19.016	-13
10	20000	1710	QPSK	-20.144	-13
			16QAM	-18.247	-13
10	20350	1755	QPSK	-20.282	-13
			16QAM	-20.213	-13
15	20025	1710	QPSK	-21.866	-13
			16QAM	-23.311	-13
15	20325	1755	QPSK	-22.332	-13
			16QAM	-21.839	-13
20	20050	1710	QPSK	-28.174	-13
			16QAM	-23.642	-13
20	20300	1755	QPSK	-26.138	-13
			16QAM	-24.570	-13

### Test Plots

#### LTE band II (Part 24E)

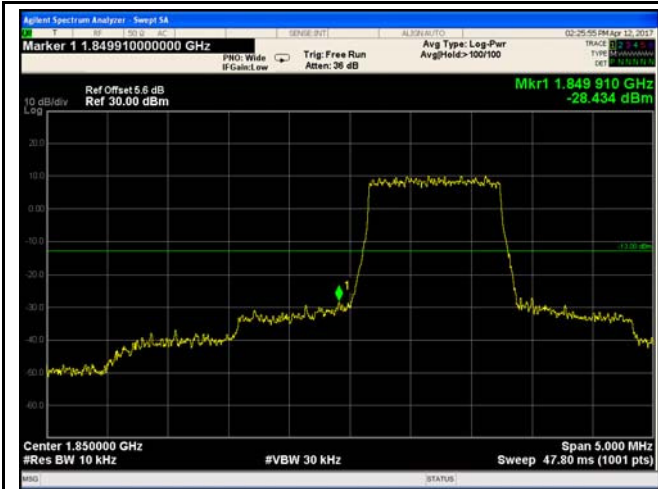

LTE band II - Low Channel QPSK-1.4

Note: Offset=Cable loss (4.5) + 10log  
 $(12.83/10)=4.5+1.1=5.6\text{dB}$



LTE band II - High Channel QPSK-1.4

Note: Offset=Cable loss (4.5) + 10log  
 $(12.69/10)=4.5+1.0=5.5\text{dB}$

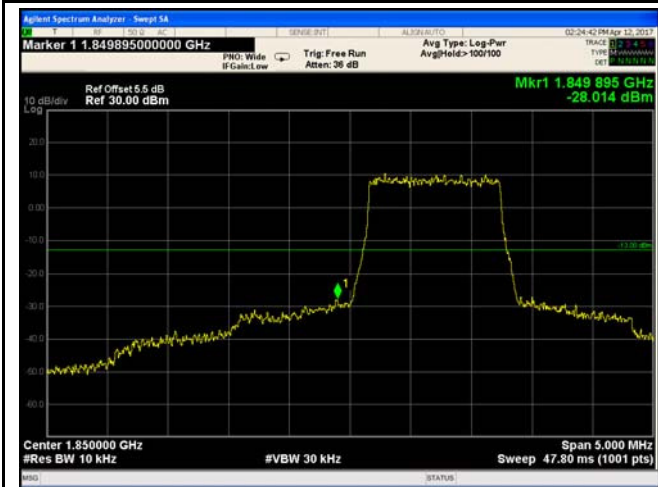

LTE band II - Low Channel 16QAM-1.4

Note: Offset=Cable loss (4.5) + 10log  
 $(12.53/10)=4.5+1.0=5.5\text{ dB}$

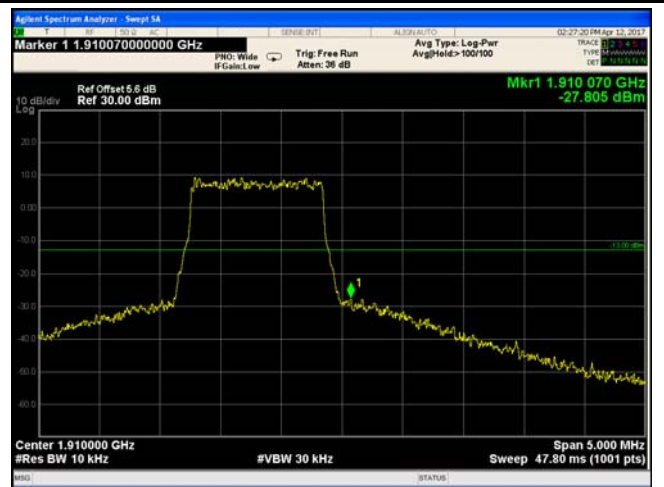

LTE band II - High Channel 16QAM-1.4

Note: Offset=Cable loss (4.5) + 10log  
 $(12.79/10)=4.5+1.1=5.6\text{ dB}$

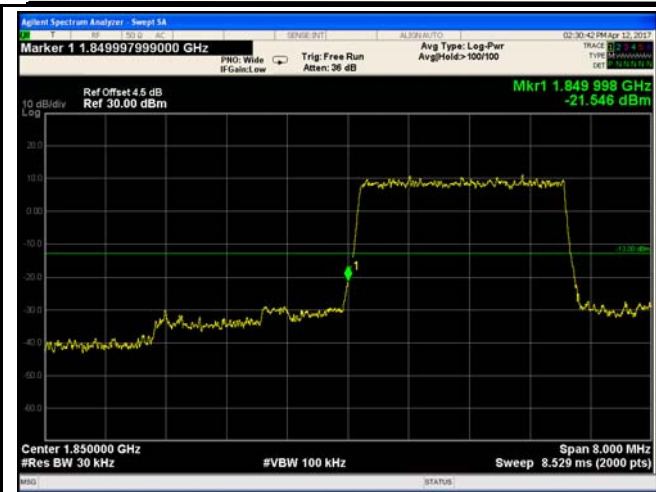

LTE band II - Low Channel QPSK-3

Note: Offset=Cable loss (4.5) + 10log  
 (30.33/30)=4.5+0.0=4.5 dB

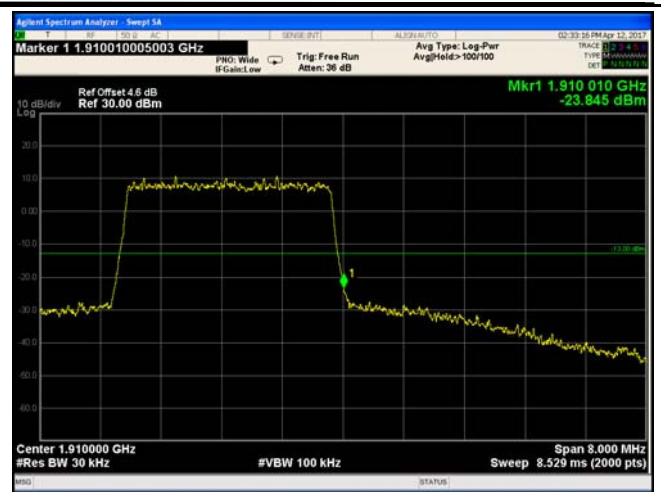

LTE band II - High Channel QPSK-3

Note: Offset=Cable loss (4.5) + 10log  
 (30.50/30)=4.5+0.1=4.6 dB

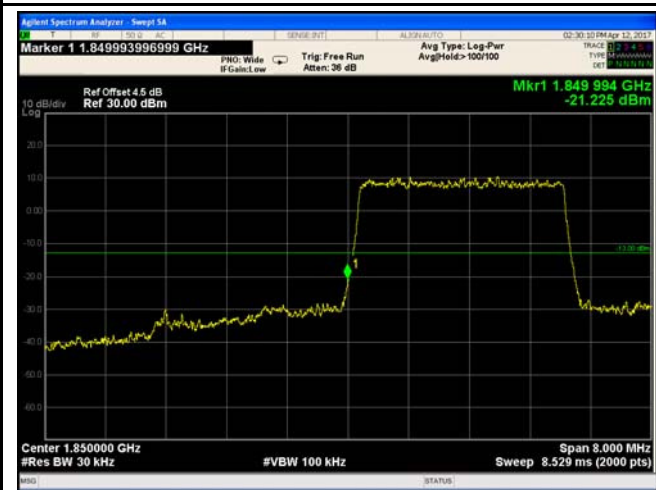

LTE band II - Low Channel 16QAM-3

Note: Offset=Cable loss (4.5) + 10log  
 (30.12/30)=4.5+0.0=4.5 dB

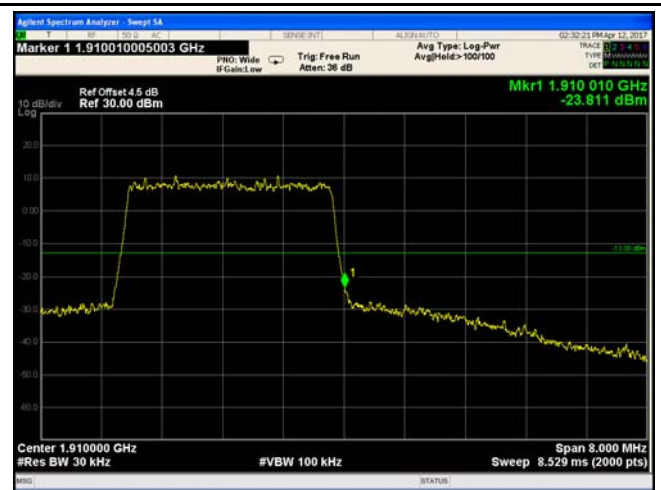

LTE band II - High Channel 16QAM-3

Note: Offset=Cable loss (4.5) + 10log  
 (30.22/30)=4.5+0.0=4.5 dB

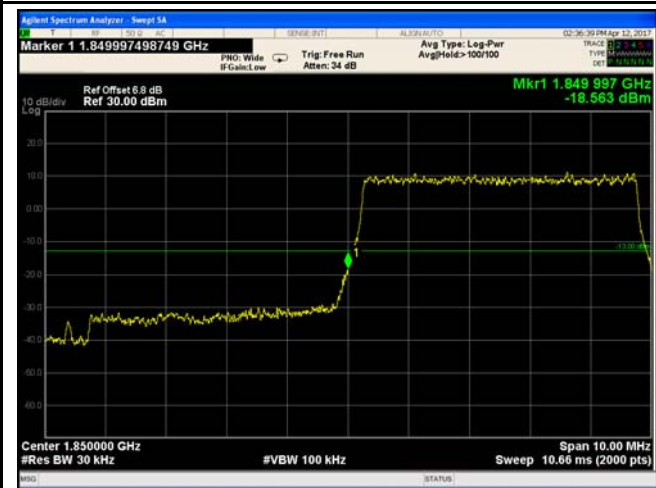

LTE band II - Low Channel QPSK-5



LTE band II - High Channel QPSK-5

Note: Offset=Cable loss (4.5) + 10log  
 $(50.87/30)=4.5+2.3=6.8$  dB

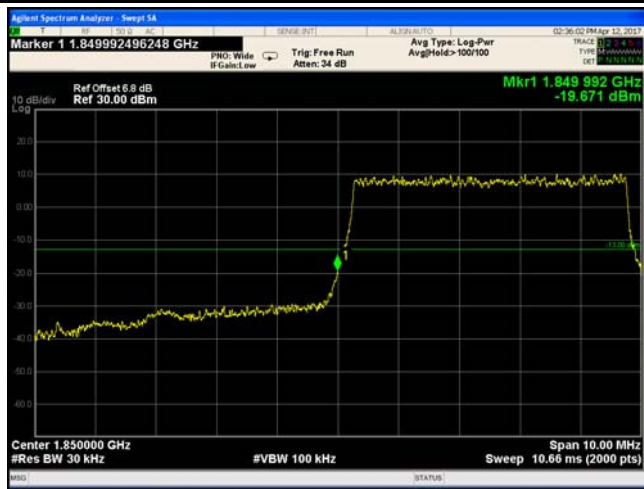

LTE band II - Low Channel 16QAM-5

Note: Offset=Cable loss (4.5) + 10log  
 $(50.37/30)=4.5+2.3=6.8$  dB



LTE band II - High Channel 16QAM-5

Note: Offset=Cable loss (4.5) + 10log  
 $(50.38/30)=4.5+2.3=6.8$  dB

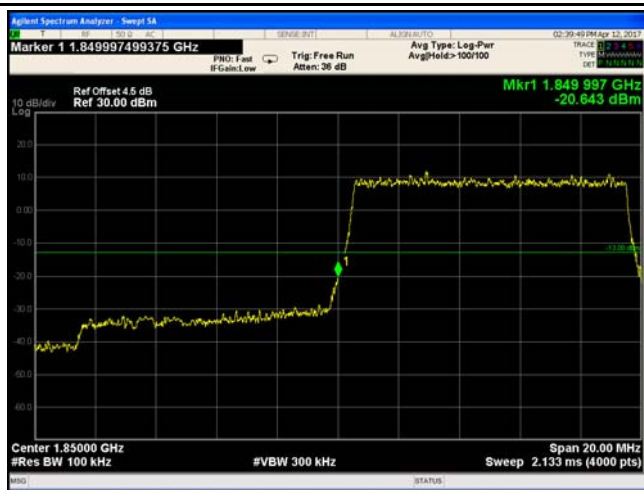

LTE band II - Low Channel QPSK-10

Note: Offset=Cable loss (4.5) + 10log  
 $(50.71/30)=4.5+2.3=6.8$  dB



LTE band II - High Channel QPSK-10

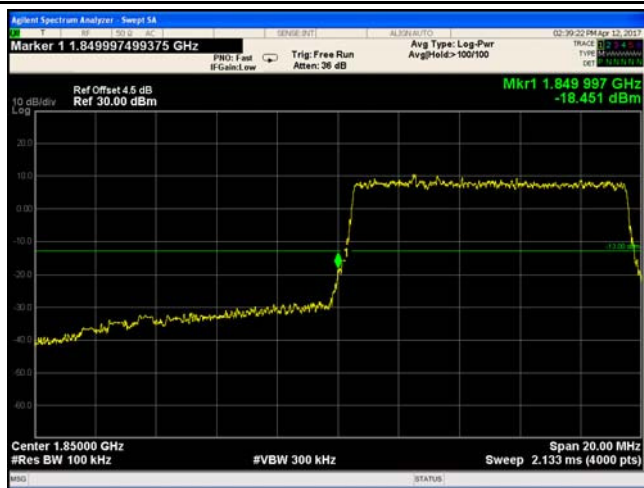

LTE band II - Low Channel 16QAM-10



LTE band II - High Channel 16QAM-10





LTE band II - Low Channel QPSK-15

Note: Offset=Cable loss (4.5) + 10log  
 (146.7/100)=4.5+1.7=6.2 dB



LTE band II - High Channel QPSK-15

Note: Offset=Cable loss (4.5) + 10log  
 (147.7/100)=4.5+1.7=6.2 dB



LTE band II - Low Channel 16QAM-15

Note: Offset=Cable loss (4.5) + 10log  
 (147.7/100)=4.5+1.7=6.2 dB



LTE band II - High Channel 16QAM-15

Note: Offset=Cable loss (4.5) + 10log  
 (147.1/100)=4.5+1.7=6.2 dB

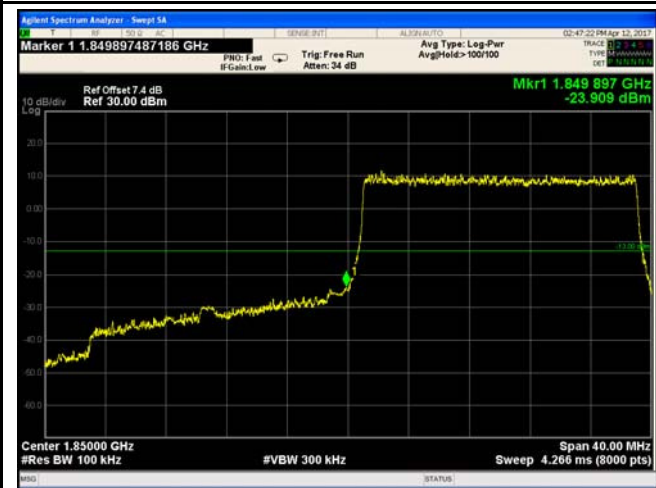

LTE band II - Low Channel QPSK-20

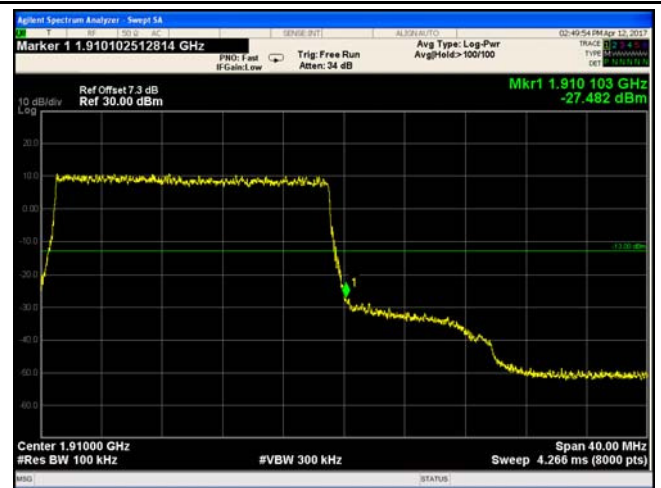

LTE band II - High Channel QPSK-20

Note: Offset=Cable loss (4.5) + 10log  
 (193.7/100)=4.5+2.9=7.4 dB



LTE band II - Low Channel 16QAM-20

Note: Offset=Cable loss (4.5) + 10log  
 (195.1/100)=4.5+2.9=7.4 dB

Note: Offset=Cable loss (4.5) + 10log  
 (192.5/100)=4.5+2.8=7.3 dB

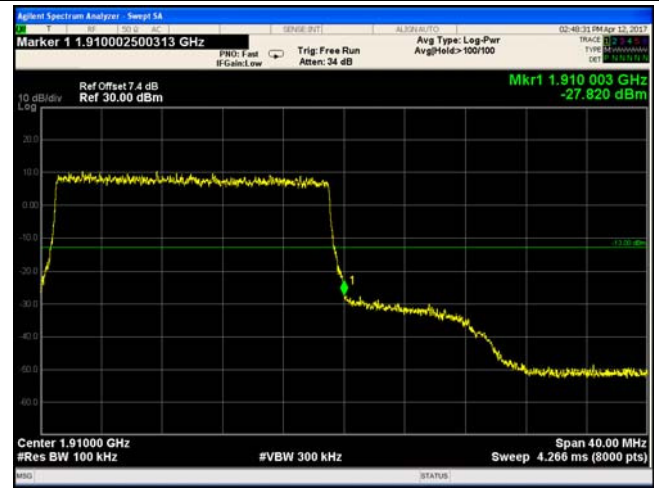

LTE band II - High Channel 16QAM-20

Note: Offset=Cable loss (4.5) + 10log  
 (193.3/100)=4.5+2.9=7.4 dB

### LTE band IV (Part 27)

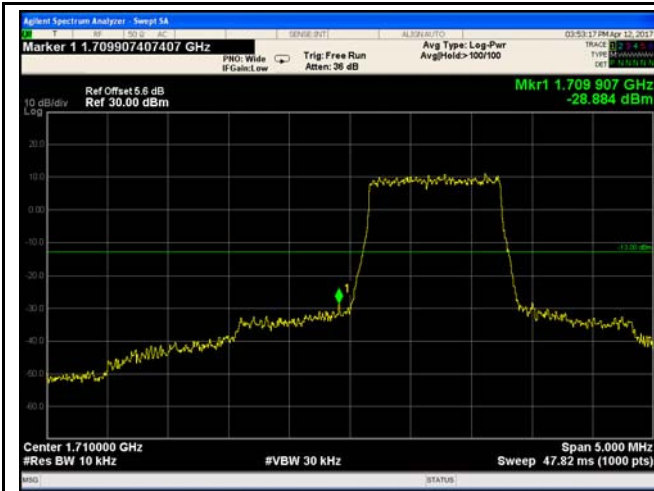

LTE band IV - Low Channel QPSK-1.4

Note: Offset=Cable loss (4.5) + 10log  
 (12.87/10)=4.5+1.1=5.6 dB

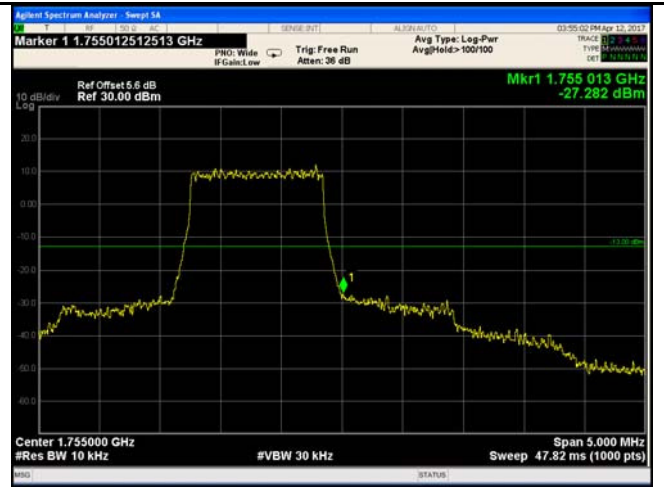

LTE band IV - High Channel QPSK-1.4

Note: Offset=Cable loss (4.5) + 10log  
 (12.94/10)=4.5+1.1=5.6 dB

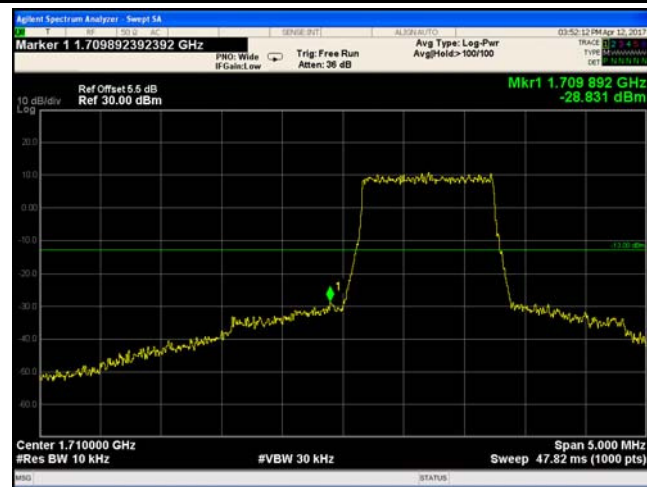

LTE band IV - Low Channel 16QAM-1.4

Note: Offset=Cable loss (4.5) + 10log  
 (12.73/10)=4.5+1.0=5.5 dB

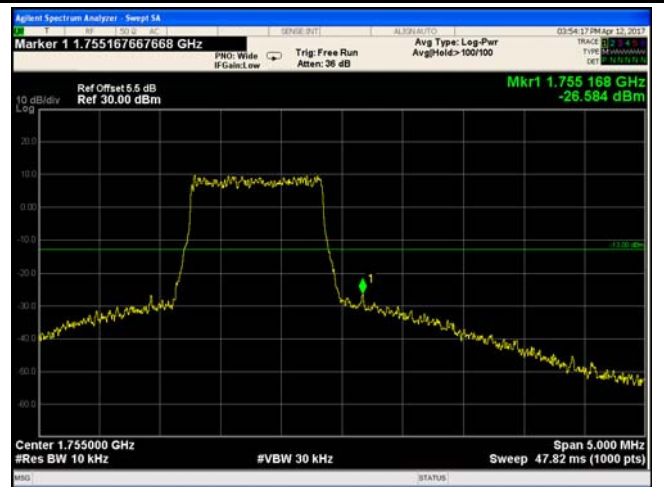

LTE band IV - High Channel 16QAM-1.4

Note: Offset=Cable loss (4.5) + 10log  
 (12.72/10)=4.5+1.0=5.5 dB



LTE band IV - Low Channel QPSK-3

Note: Offset=Cable loss (4.5) + 10log  
 $(30.33/30)=4.5+0.0=4.5$  dB



LTE band IV - High Channel QPSK-3

Note: Offset=Cable loss (4.5) + 10log  
 $(30.55/30)=4.5+0.1=4.6$  dB

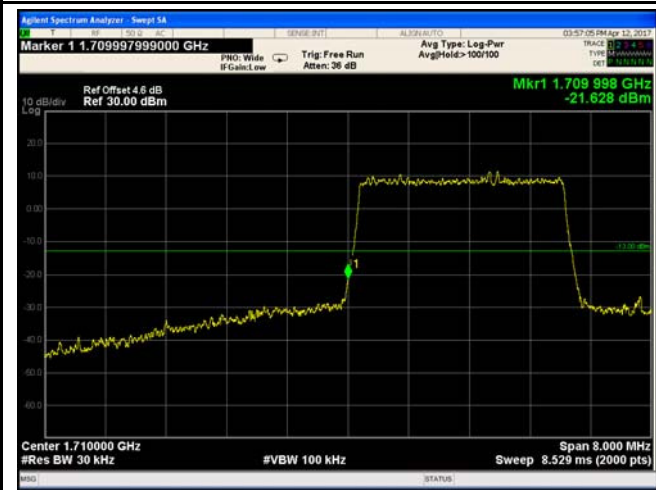

LTE band IV - Low Channel 16QAM-3

Note: Offset=Cable loss (4.5) + 10log  
 $(30.47/30)=4.5+0.1=4.6$  dB



LTE band IV - High Channel 16QAM-3

Note: Offset=Cable loss (4.5) + 10log  
 $(30.65/30)=4.5+0.1=4.6$  dB

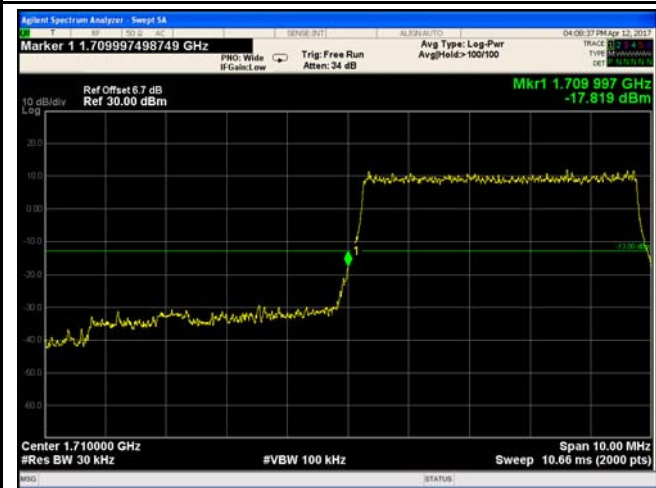

LTE band IV - Low Channel QPSK-5



LTE band IV - High Channel QPSK-5