

# RF TEST REPORT



Report No.: 17070226-FCC-R3

Supersede Report No.: N/A

Applicant	TECNO MOBILE LIMITED	
Product Name	Mobile phone	
Model No.	WX4 Pro	
Serial No.	N/A	
Test Standard	FCC Part 15.247: 2016, ANSI C63.10: 2013	
Test Date	March 28 to April 17, 2017	
Issue Date	April 17, 2017	
Test Result	<input checked="" type="checkbox"/> Pass <input type="checkbox"/> Fail	
Equipment complied with the specification	<input checked="" type="checkbox"/>	
Equipment did not comply with the specification	<input type="checkbox"/>	
		
Loren Luo Test Engineer	David Huang Checked By	
This test report may be reproduced in full only Test result presented in this test report is applicable to the tested sample only		

Issued by:

**SIEMIC (SHENZHEN-CHINA) LABORATORIES**

Zone A, Floor 1, Building 2 Wan Ye Long Technology Park

South Side of Zhoushi Road, Bao' an District, Shenzhen, Guangdong China 518108

Phone: +86 0755 2601 4629801 Email: [China@siemic.com.cn](mailto:China@siemic.com.cn)

## Laboratories Introduction

SIEMIC, headquartered in the heart of Silicon Valley, with superior facilities in US and Asia, is one of the leading independent testing and certification facilities providing customers with one-stop shop services for Compliance Testing and Global Certifications.



In addition to testing and certification, SIEMIC provides initial design reviews and compliance management throughout a project. Our extensive experience with China, Asia Pacific, North America, European, and International compliance requirements, assures the fastest, most cost effective way to attain regulatory compliance for the global markets.

### Accreditations for Conformity Assessment

Country/Region	Scope
USA	EMC, RF/Wireless, SAR, Telecom
Canada	EMC, RF/Wireless, SAR, Telecom
Taiwan	EMC, RF, Telecom, SAR, Safety
Hong Kong	RF/Wireless, SAR, Telecom
Australia	EMC, RF, Telecom, SAR, Safety
Korea	EMI, EMS, RF, SAR, Telecom, Safety
Japan	EMI, RF/Wireless, SAR, Telecom
Singapore	EMC, RF, SAR, Telecom
Europe	EMC, RF, SAR, Telecom, Safety

Test Report	17070226-FCC-R3
Page	3 of 66

This page has been left blank intentionally.

# CONTENTS

<b>1. REPORT REVISION HISTORY .....</b>	<b>5</b>
<b>2. CUSTOMER INFORMATION .....</b>	<b>5</b>
<b>3. TEST SITE INFORMATION.....</b>	<b>5</b>
<b>4. EQUIPMENT UNDER TEST (EUT) INFORMATION.....</b>	<b>6</b>
<b>5. TEST SUMMARY .....</b>	<b>8</b>
<b>6. MEASUREMENTS, EXAMINATION AND DERIVED RESULTS .....</b>	<b>9</b>
6.1 ANTENNA REQUIREMENT.....	9
6.2 CHANNEL SEPARATION .....	10
6.3 20DB BANDWIDTH .....	14
6.4 PEAK OUTPUT POWER.....	18
6.5 NUMBER OF HOPPING CHANNEL.....	22
6.6 TIME OF OCCUPANCY (DWEEL TIME) .....	24
6.7 BAND EDGE & RESTRICTED BAND .....	28
6.8 AC POWER LINE CONDUCTED EMISSIONS.....	36
6.9 RADIATED EMISSIONS & RESTRICTED BAND .....	42
<b>ANNEX A. TEST INSTRUMENT.....</b>	<b>48</b>
<b>ANNEX B. EUT AND TEST SETUP PHOTOGRAPHS.....</b>	<b>49</b>
<b>ANNEX C. TEST SETUP AND SUPPORTING EQUIPMENT.....</b>	<b>61</b>
<b>ANNEX D. USER MANUAL / BLOCK DIAGRAM / SCHEMATICS / PARTLIST.....</b>	<b>65</b>
<b>ANNEX E. DECLARATION OF SIMILARITY.....</b>	<b>66</b>

## 1. Report Revision History

Report No.	Report Version	Description	Issue Date
17070226-FCC-R3	NONE	Original	April 17, 2017

## 2. Customer information

Applicant Name	TECNO MOBILE LIMITED
Applicant Add	ROOMS 05-15, 13A/F., SOUTH TOWER, WORLD FINANCE CENTRE, HARBOUR CITY, 17 CANTON ROAD, TSIM SHA TSUI, KOWLOON, HONG KONG
Manufacturer	SHENZHEN TECNO TECHNOLOGY CO.,LTD.
Manufacturer Add	1-4th Floor,3rd Building,Pacific Industrial Park,No.2088,Shenyan Road,Yantian District,Shenzhen,Guangdong,China

## 3. Test site information

Lab performing tests	SIEMIC (Shenzhen-China) LABORATORIES
Lab Address	Zone A, Floor 1, Building 2 Wan Ye Long Technology Park South Side of Zhoushi Road, Bao' an District, Shenzhen, Guangdong China 518108
FCC Test Site No.	718246
IC Test Site No.	4842E-1
Test Software of Radiated Emission	Radiated Emission Program-To Shenzhen v2.0
Test Software of Conducted Emission	EZ-EMC(ver.lcp-03A1)

## 4. Equipment under Test (EUT) Information

Description of EUT:	Mobile phone
Main Model:	WX4 Pro
Serial Model:	N/A
Date EUT received:	March 27, 2017
Test Date(s):	March 28 to April 17, 2017
Equipment Category :	DSS
Antenna Gain:	GSM850: -0.2dBi PCS1900:1.7dBi UMTS-FDD Band V: -0.2dBi UMTS-FDD Band II:1.7dBi LTE Band II:1.7dBi LTE Band IV:1.7dBi LTE Band VII:2.5dBi WIFI:2.0dBi Bluetooth/BLE:2.0dBi GPS: 1.7dBi
Antenna Type:	PIFA antenna
Type of Modulation:	GSM / GPRS: GMSK EGPRS: GMSK,8PSK UMTS-FDD: QPSK LTE Band: QPSK, 16QAM 802.11b/g/n: DSSS, OFDM Bluetooth: GFSK, $\pi$ /4DQPSK, 8DPSK BLE: GFSK GPS:BPSK

GSM850 TX: 824.2 ~ 848.8 MHz; RX: 869.2 ~ 893.8 MHz  
 PCS1900 TX: 1850.2 ~ 1909.8 MHz; RX: 1930.2 ~ 1989.8 MHz  
 UMTS-FDD Band V TX: 826.4 ~ 846.6 MHz; RX: 871.4 ~ 891.6 MHz  
 UMTS-FDD Band II TX:1852.4 ~ 1907.6 MHz;  
 RX: 1932.4 ~ 1987.6 MHz

RF Operating Frequency (ies):

LTE Band II TX: 1850.7~ 1909.3 MHz; RX : 1930.7 ~ 1989.3 MHz  
 LTE Band IV TX: 1710.7 ~ 1754.3 MHz; RX : 2110.7 ~ 2154.3 MHz  
 LTE Band VII TX: 2502.5 ~ 2567.5 MHz; RX : 2622.5 ~ 2687.5 MHz  
 WIFI: 802.11b/g/n(20M): 2412-2462 MHz  
 WIFI: 802.11n(40M): 2422-2452 MHz  
 Bluetooth& BLE: 2402-2480 MHz  
 GPS: 1575.42 MHz

Max. Output Power:

2.465dBm

Number of Channels:

GSM 850: 124CH  
 PCS1900: 299CH  
 UMTS-FDD Band V : 102CH  
 UMTS-FDD Band II : 277CH  
 WIFI :802.11b/g/n(20M): 11CH  
 WIFI :802.11n(40M): 7CH  
 Bluetooth: 79CH  
 BLE: 40CH  
 GPS:1CH

Port:

USB Port, Earphone Port

Input Power:

Adapter:  
 Model:A8-501000  
 Input: AC100-240V~50/60Hz,200mA  
 Output: DC 5.0V,1.0A  
 Battery:  
 Model:BL-28BT  
 Spec:3.85V,10.78Wh,2800mAh  
 Limited charge voltage:4.4V

Trade Name :

TECNO

FCC ID:

2ADYY-WX4PRO

## 5. Test Summary

The product was tested in accordance with the following specifications.

All testing has been performed according to below product classification:

FCC Rules	Description of Test	Result
§15.203	Antenna Requirement	Compliance
§15.247(a)(1)	Channel Separation	Compliance
§15.247(a)(1)	20 dB Bandwidth	Compliance
§15.247(b)(1)	Peak Output Power	Compliance
§15.247(a)(1)(iii)	Number of Hopping Channel	Compliance
§15.247(a)(1)(iii)	Time of Occupancy (Dwell Time)	Compliance
§15.247(d)	Band Edge& Restricted Band	Compliance
§15.207(a)	AC Line Conducted Emissions	Compliance
§15.205, §15.209, §15.247(d)	Radiated Emissions& Restricted Band	Compliance

### Measurement Uncertainty

Emissions		
Test Item	Description	Uncertainty
Band Edge& Restricted Band and Radiated Emissions& Restricted Band	Confidence level of approximately 95% (in the case where distributions are normal), with a coverage factor of 2 (for EUTs < 0.5m X 0.5m X 0.5m)	+5.6dB/-4.5dB
-	-	-



## 6. Measurements, Examination And Derived Results

### 6.1 Antenna Requirement

#### **Applicable Standard**

According to § 15.203, an intentional radiator shall be designed to ensure that no antenna other than that furnished by the responsible party shall be used with the device. The use of a permanently attached antenna or of an antenna that uses a unique coupling to the intentional radiator shall be considered sufficient to comply with the provisions of this section. The manufacturer may design the unit so that a broken antenna can be replaced by the user, but the user of a standard antenna jack or electrical connector is prohibited. The structure and application of the EUT were analyzed to determine compliance with section §15.203 of the rules. §15.203 state that the subject device must meet the following criteria:

- a. Antenna must be permanently attached to the unit.
- b. Antenna must use a unique type of connector to attach to the EUT.

Unit must be professionally installed, and installer shall be responsible for verifying that the correct antenna is employed with the unit.

And according to FCC 47 CFR section 15.247 (b), if the transmitting antennas of directional gain greater than 6dBi are used, the power shall be reduced by the amount in dB that the directional gain of the antenna exceeds 6 dBi.

#### **Antenna Connector Construction**

The EUT has 3 antennas:

A permanently attached PIFA antenna for Bluetooth/BLE/WIFI/GPS, the gain is 2.0dBi for Bluetooth/BLE and WIFI, 1.7dBi for GPS.

A permanently attached PIFA antenna for GSM/PCS/UMTS, the gain is -0.2dBi for GSM850, 1.7dBi for PCS1900, -0.2dBi for UMTS-FDD Band V, 1.7dBi for UMTS-FDD Band II.

A permanently attached PIFA antenna for LTE Band II/IV/VII, the gain is 1.7dBi for LTE Band II, the gain is 1.7dBi for LTE Band IV, the gain is 2.5dBi for LTE Band VII.

**The antenna meets up with the ANTENNA REQUIREMENT.**

**Result:** Compliance.

## 6.2 Channel Separation

Temperature	24°C
Relative Humidity	52%
Atmospheric Pressure	1007mbar
Test date :	April 10, 2017
Tested By :	Loren Luo

### Requirement(s):

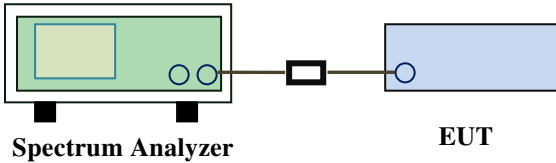
Spec	Item	Requirement	Applicable
§ 15.247(a)(1)	a)	Channel Separation < 20dB BW and 20dB BW < 25KHz ; Channel Separation Limit=25KHz Chanel Separation < 20dB BW and 20dB BW > 25kHz ; Channel Separation Limit=2/3 20dB BW	<input checked="" type="checkbox"/>
Test Setup	 <p style="text-align: center;">Spectrum Analyzer                      EUT</p>		
Test Procedure	<p>The test follows FCC Public Notice DA 00-705 Measurement Guidelines. Use the following spectrum analyzer settings:</p> <ul style="list-style-type: none"> <li>- The EUT must have its hopping function enabled</li> <li>- Span = wide enough to capture the peaks of two adjacent channels</li> <li>- Resolution (or IF) Bandwidth (RBW) ≥ 1% of the span</li> <li>- Video (or Average) Bandwidth (VBW) ≥ RBW</li> <li>- Sweep = auto</li> <li>- Detector function = peak</li> <li>- Trace = max hold</li> <li>- Allow the trace to stabilize. Use the marker-delta function to determine the separation between the peaks of the adjacent channels. The limit is specified in one of the subparagraphs of this Section. Submit this plot.</li> </ul>		

Remark	
Result	<input checked="" type="checkbox"/> Pass <input type="checkbox"/> Fail

Test Data  Yes  N/A

Test Plot  Yes (See below)  N/A

### Channel Separation measurement result

Type/ Modulation	CH	CH Frequency (MHz)	CH Separation (MHz)	Limit (MHz)	Result
CH Separation GFSK	Low Channel	2402	1.005	0.683	Pass
	Adjacency Channel	2403			
	Mid Channel	2440	1.005	0.684	Pass
	Adjacency Channel	2441			
	High Channel	2480	1.005	0.694	Pass
	Adjacency Channel	2479			
CH Separation $\pi/4$ DQPSK	Low Channel	2402	1.005	0.868	Pass
	Adjacency Channel	2403			
	Mid Channel	2440	1.005	0.873	Pass
	Adjacency Channel	2441			
	High Channel	2480	1.005	0.866	Pass
	Adjacency Channel	2479			
CH Separation 8DPSK	Low Channel	2402	1.005	0.876	Pass
	Adjacency Channel	2403			
	Mid Channel	2440	1.005	0.871	Pass
	Adjacency Channel	2441			
	High Channel	2480	1.005	0.866	Pass
	Adjacency Channel	2479			

### Test Plots

### Channel Separation measurement result

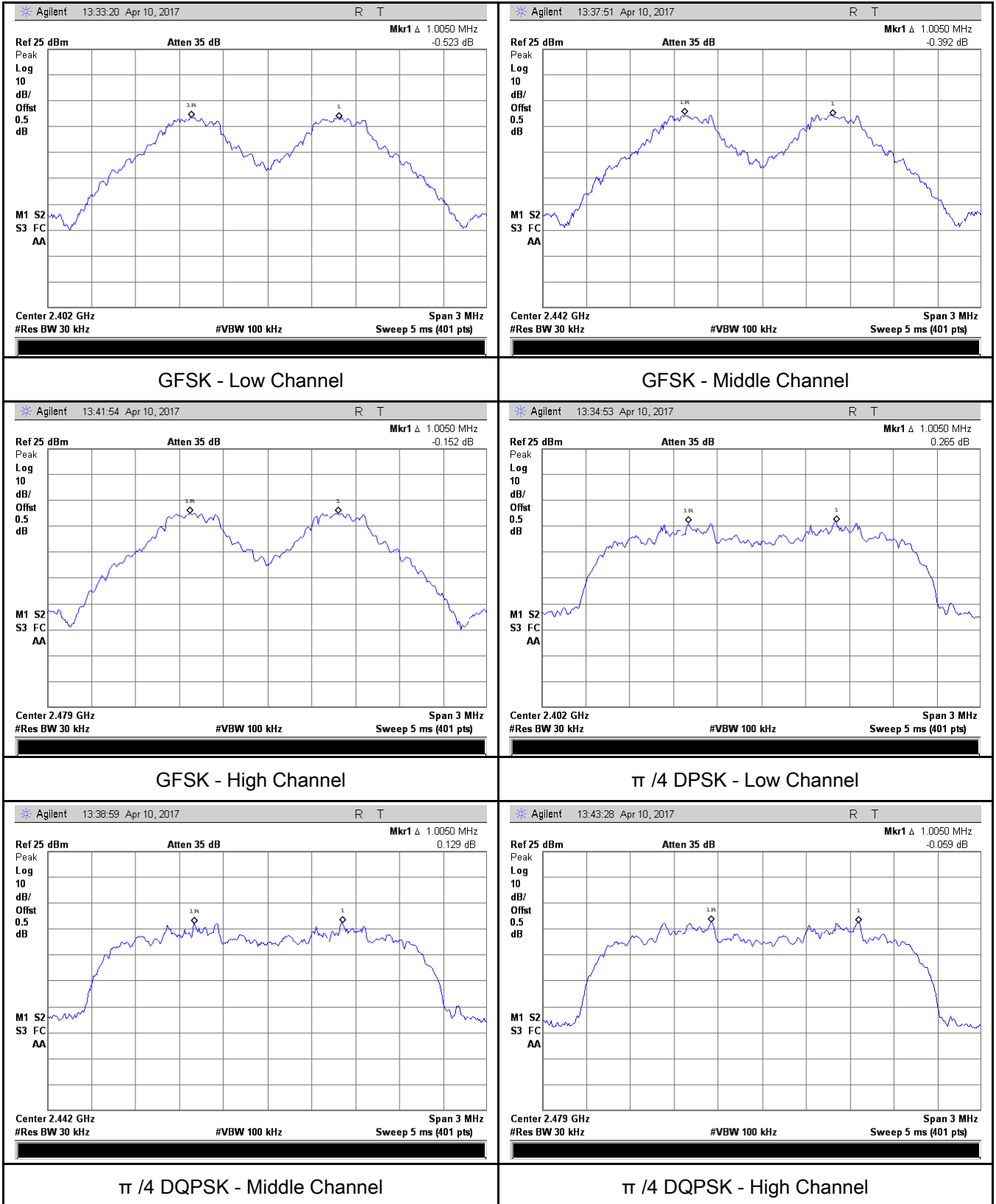

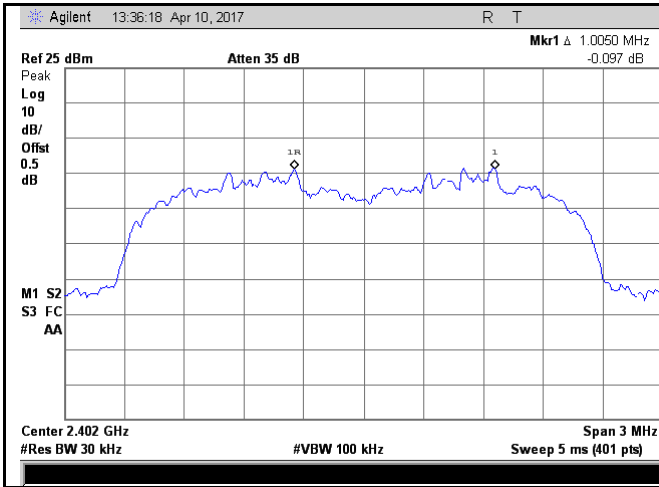

8DPSK - Low Channel

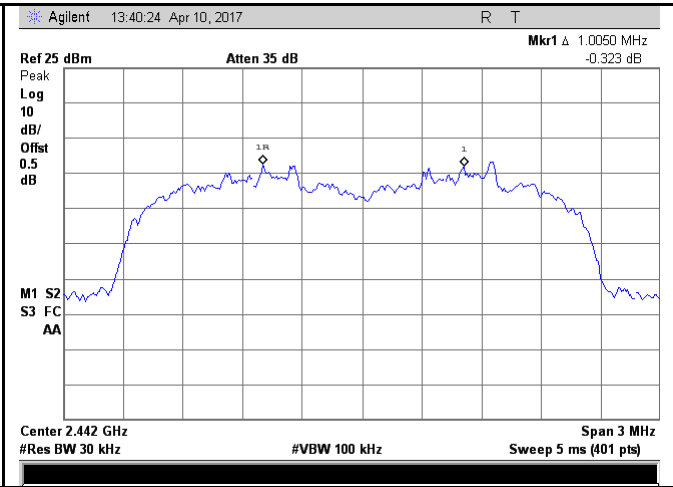

8DPSK - Middle Channel

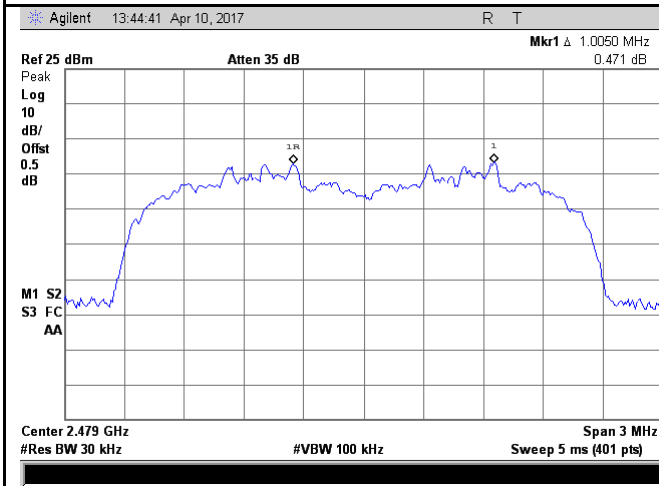

8DPSK - High Channel

### 6.3 20dB Bandwidth

Temperature	24°C
Relative Humidity	52%
Atmospheric Pressure	1007mbar
Test date :	April 10, 2017
Tested By :	Loren Luo

#### Requirement(s):

Spec	Item	Requirement	Applicable
§15.247(a) (1)	a)	Frequency hopping systems shall have hopping channel carrier frequencies separated by a minimum of 25 kHz or the 20 dB bandwidth of the hopping channel, whichever is greater.	<input checked="" type="checkbox"/>

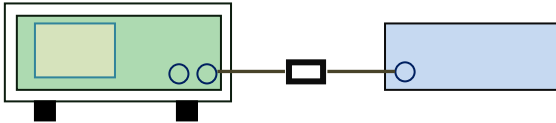
Test Setup	 <p style="text-align: center;">Spectrum Analyzer                      EUT</p>
------------	--

Test Procedure	<p>The test follows FCC Public Notice DA 00-705 Measurement Guidelines. Use the following spectrum analyzer settings:</p> <ul style="list-style-type: none"> <li>- Span = approximately 2 to 3 times the 20 dB bandwidth, centered on a hopping channel</li> <li>- RBW <math>\geq</math> 1% of the 20 dB bandwidth</li> <li>- VBW <math>\geq</math> RBW</li> <li>- Sweep = auto</li> <li>- Detector function = peak</li> <li>- Trace = max hold.</li> <li>- The EUT should be transmitting at its maximum data rate. Allow the trace to stabilize. Use the marker-to-peak function to set the marker to the peak of the emission. Use the marker-delta function to measure 20 dB down one side of the emission. Reset the marker-delta function, and move the marker to the other side of the emission, until it is (as close as possible to) even with the reference</li> </ul>
----------------	--

	marker level. The marker-delta reading at this point is the 20 dB bandwidth of the emission. If this value varies with different modes of operation (e.g., data rate, modulation format, etc.), repeat this test for each variation. The limit is specified in one of the subparagraphs of this Section. Submit this plot(s).
Remark	
Result	<input checked="" type="checkbox"/> Pass <input type="checkbox"/> Fail

Test Data  Yes  N/A

Test Plot  Yes (See below)  N/A

#### Measurement result

Modulation	CH	CH Frequency (MHz)	20dB Bandwidth (MHz)	99% Occupied Bandwidth (MHz)
GFSK	Low	2402	1.025	0.8874
	Mid	2441	1.026	0.8972
	High	2480	1.041	0.8978
$\pi/4$ DQPSK	Low	2402	1.302	1.1766
	Mid	2441	1.310	1.1781
	High	2480	1.299	1.1724
8-DPSK	Low	2402	1.314	1.1927
	Mid	2441	1.307	1.1881
	High	2480	1.299	1.1822

## Test Plots

### 20dB Bandwidth measurement result

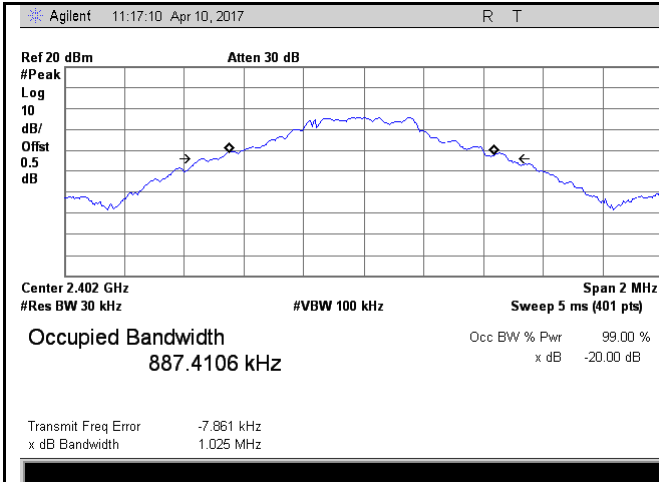

GFSK - Low Channel

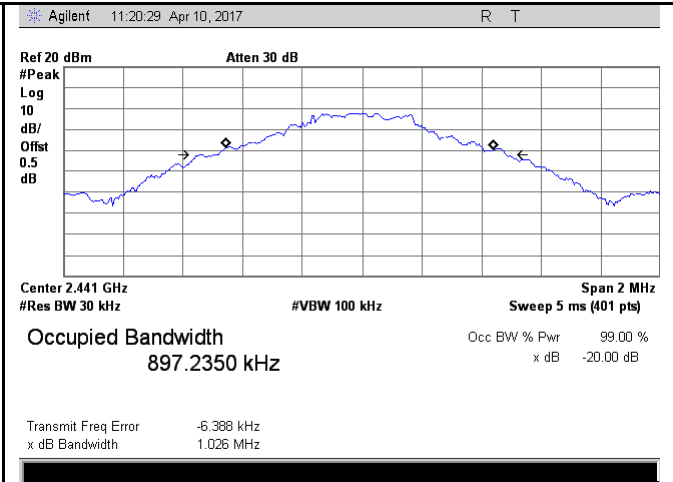

GFSK - Middle Channel

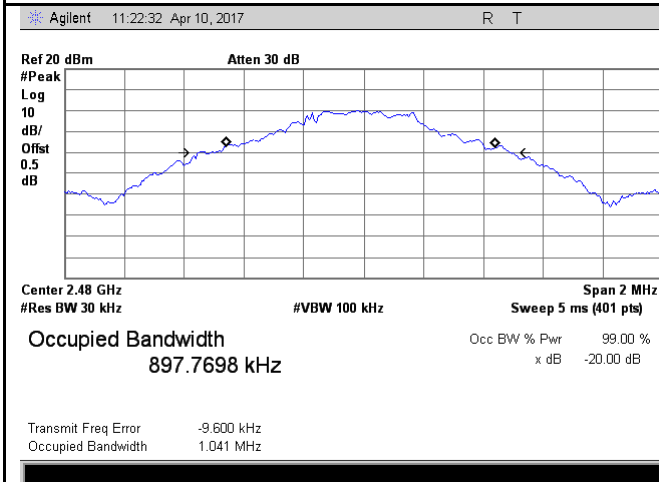

GFSK - High Channel

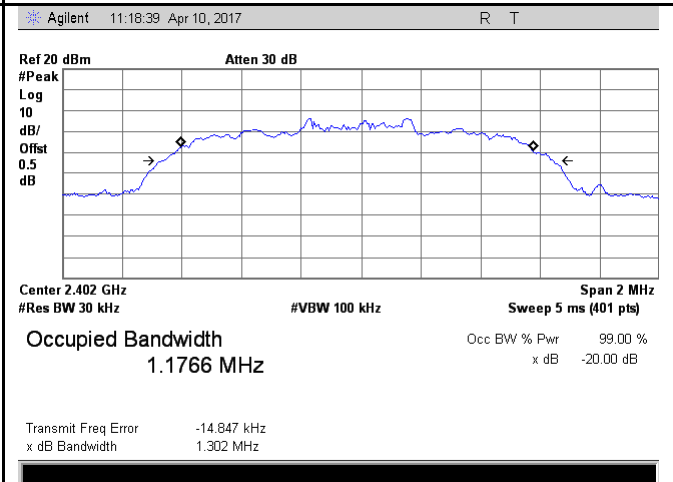

$\pi/4$  DPSK - Low Channel

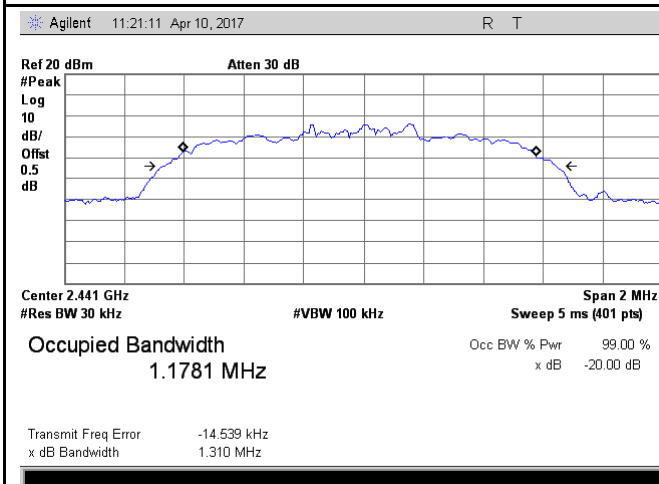

$\pi/4$  DQPSK - Middle Channel

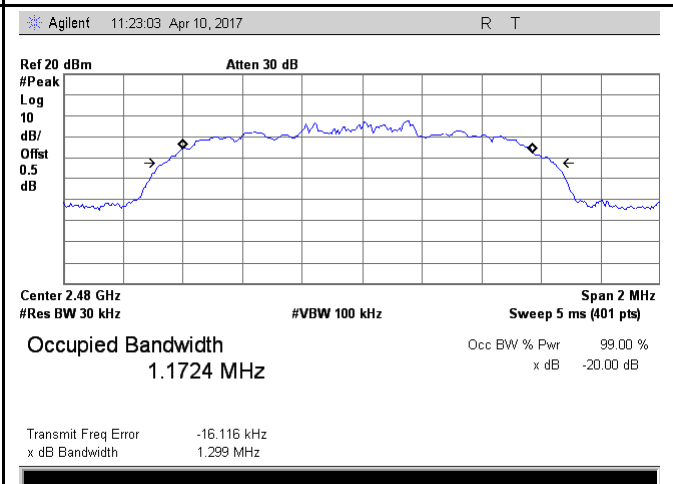

$\pi/4$  DQPSK - High Channel



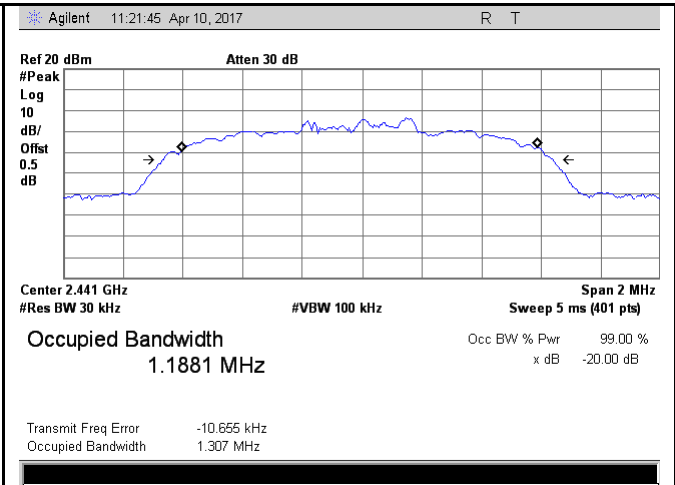
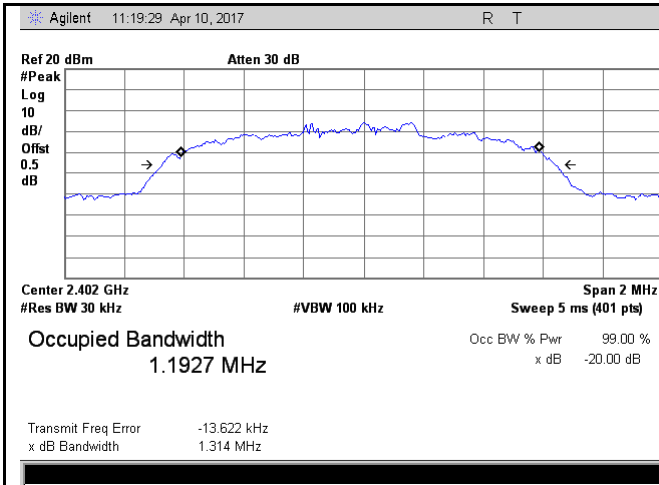

8DPSK - Low Channel

8DPSK - Middle Channel

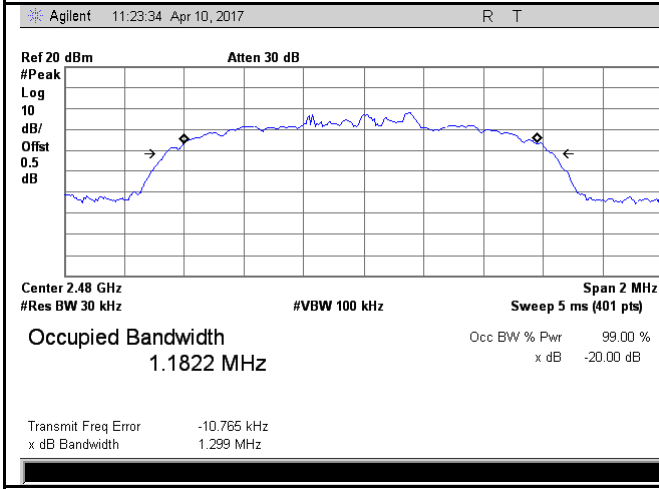

8DPSK - High Channel

## 6.4 Peak Output Power

Temperature	24°C
Relative Humidity	52%
Atmospheric Pressure	1007mbar
Test date :	April 10, 2017
Tested By :	Loren Luo

### Requirement(s):

Spec	Item	Requirement	Applicable
§15.247(b) (3)	a)	FHSS in 2400-2483.5MHz with $\geq 75$ channels: $\leq 1$ Watt	<input checked="" type="checkbox"/>
	b)	FHSS in 5725-5850MHz: $\leq 1$ Watt	<input type="checkbox"/>
	c)	For all other FHSS in the 2400-2483.5MHz band: $\leq 0.125$ Watt.	<input checked="" type="checkbox"/>
	d)	FHSS in 902-928MHz with $\geq 50$ channels: $\leq 1$ Watt	<input type="checkbox"/>
	e)	FHSS in 902-928MHz with $\geq 25$ & $< 50$ channels: $\leq 0.25$ Watt	<input type="checkbox"/>
	f)	DTS in 902-928MHz, 2400-2483.5MHz: $\leq 1$ Watt	<input type="checkbox"/>

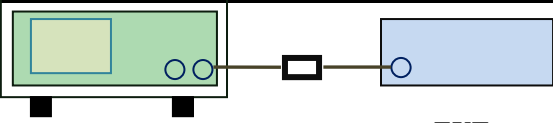
Test Setup	 <p style="text-align: center;">Spectrum Analyzer                      EUT</p>
------------	--

Test Procedure	<p>The test follows FCC Public Notice DA 00-705 Measurement Guidelines.</p> <p><u>Use the following spectrum analyzer settings:</u></p> <ul style="list-style-type: none"> <li>- Span = approximately 5 times the 20 dB bandwidth, centered on a hopping channel</li> <li>- RBW &gt; the 20 dB bandwidth of the emission being measured</li> <li>- VBW <math>\geq</math> RBW</li> <li>- Sweep = auto</li> <li>- Detector function = peak</li> <li>- Trace = max hold</li> <li>- Allow the trace to stabilize.</li> </ul>
----------------	--

	<ul style="list-style-type: none"> <li>- Use the marker-to-peak function to set the marker to the peak of the emission. The indicated level is the peak output power (see the note above regarding external attenuation and cable loss). The limit is specified in one of the subparagraphs of this Section. Submit this plot. A peak responding power meter may be used instead of a spectrum analyzer.</li> </ul>
Remark	
Result	<input checked="" type="checkbox"/> Pass <input type="checkbox"/> Fail

Test Data     Yes                       N/A  
 Test Plot      Yes (See below)             N/A

**Peak Output Power measurement result**

Type	Modulation	CH	Frequency (MHz)	Conducted Power (dBm)	Limit (mW)	Result
Output power	GFSK	Low	2402	0.691	125	Pass
		Mid	2441	2.134	125	Pass
		High	2480	<b>2.465</b>	125	Pass
	$\pi/4$ DQPSK	Low	2402	-0.032	125	Pass
		Mid	2441	1.246	125	Pass
		High	2480	1.496	125	Pass
	8-DPSK	Low	2402	-0.096	125	Pass
		Mid	2441	1.331	125	Pass
		High	2480	1.903	125	Pass

### Test Plots

#### Output Power measurement result

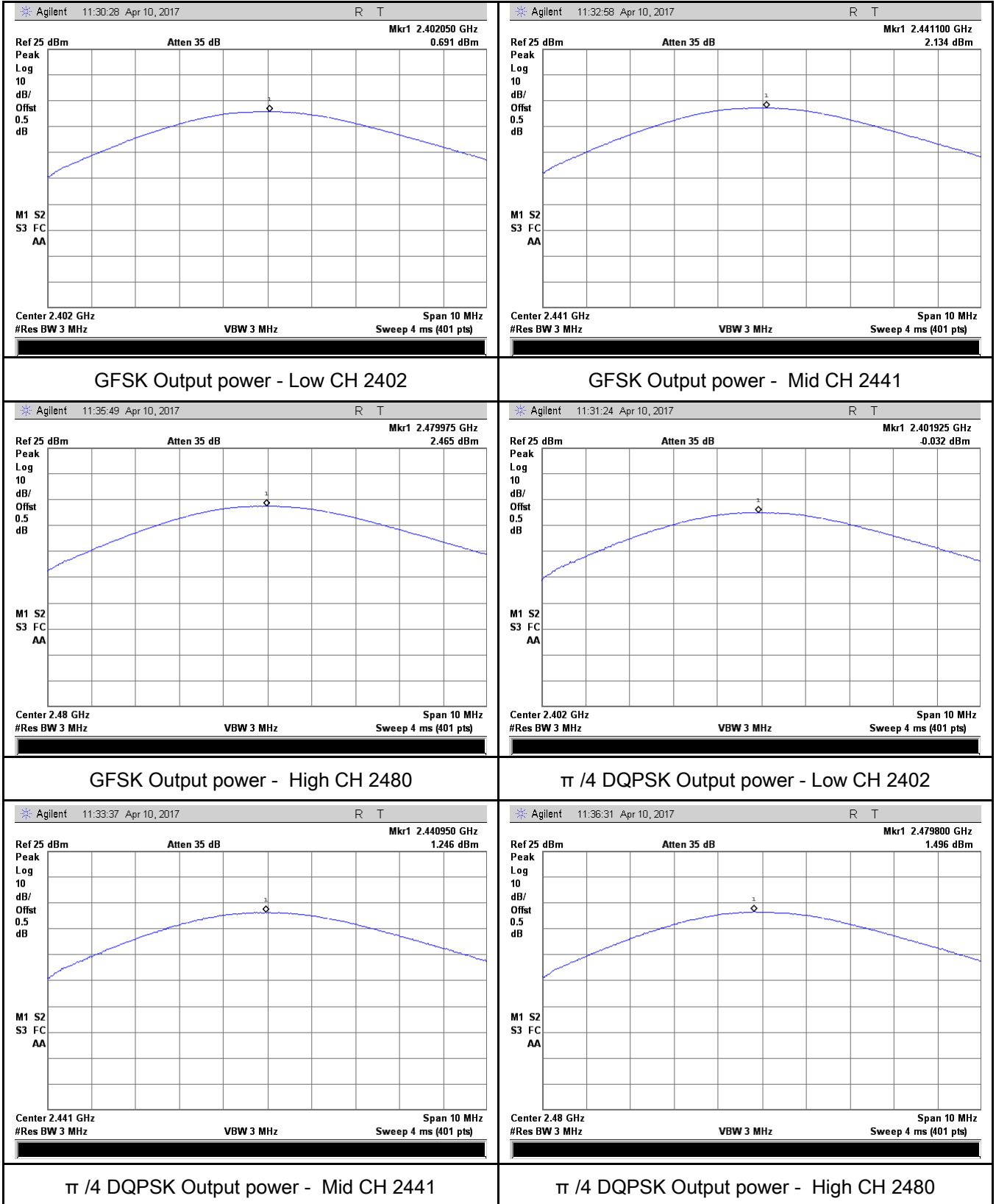

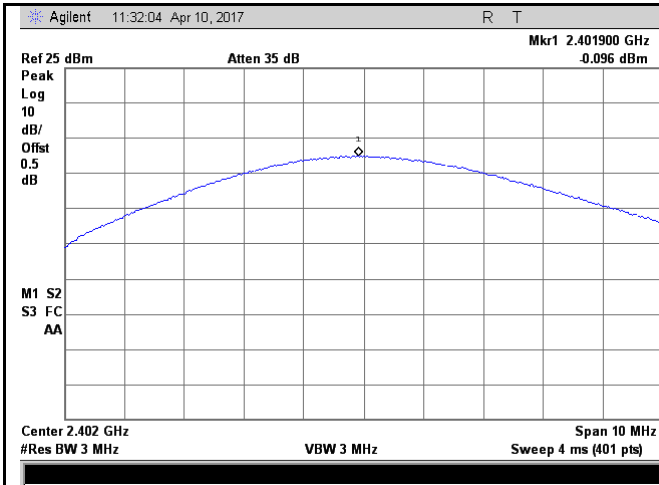

8DPSK Output power - Low CH 2402

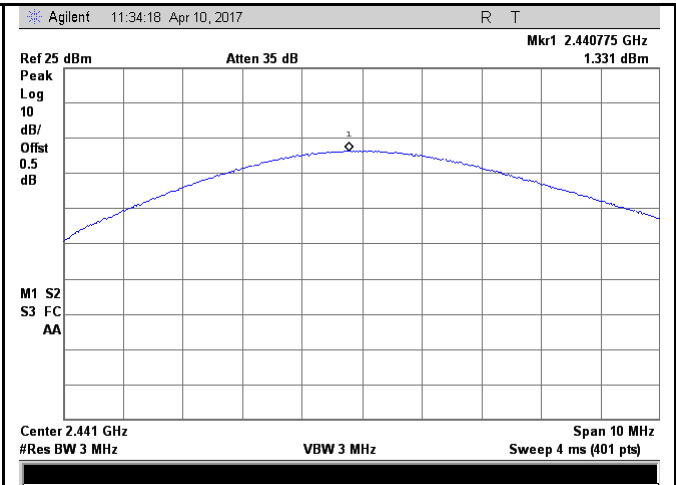

8DPSK Output power - Mid CH 2441

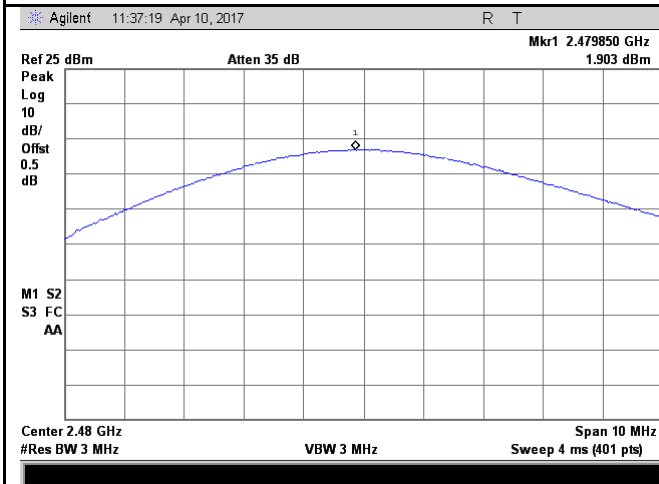

8DPSK Output power - High CH 2480

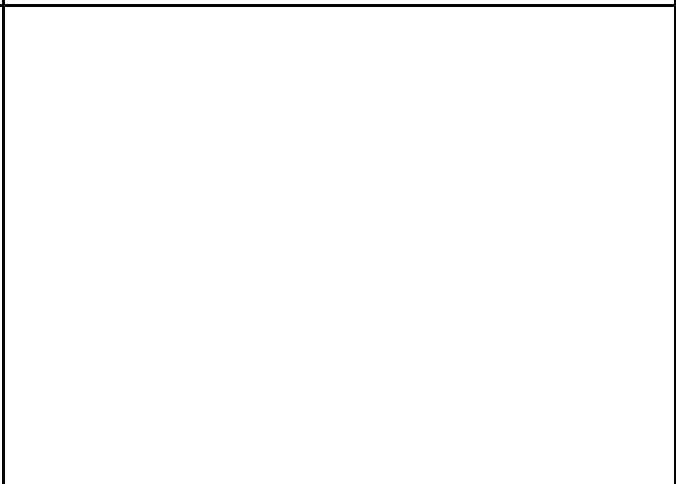

## 6.5 Number of Hopping Channel

Temperature	24°C
Relative Humidity	52%
Atmospheric Pressure	1007mbar
Test date :	April 10, 2017
Tested By :	Loren Luo

### Requirement(s):

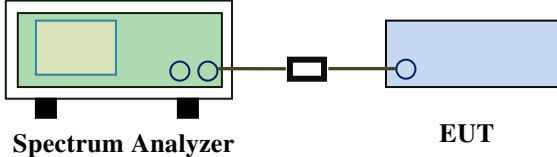
Spec	Item	Requirement	Applicable
§15.247(a) (1)(iii)	a)	FHSS in 2400-2483.5MHz ≥ 15 channels	<input checked="" type="checkbox"/>
Test Setup	 <p style="text-align: center;">Spectrum Analyzer                      EUT</p>		
Test Procedure	<p>The test follows FCC Public Notice DA 00-705 Measurement Guidelines.  <u>Use the following spectrum analyzer settings:</u>            The EUT must have its hopping function enabled.</p> <ul style="list-style-type: none"> <li>- Span = the frequency band of operation</li> <li>- RBW ≥ 1% of the span</li> <li>- VBW ≥ RBW</li> <li>- Sweep = auto</li> <li>- Detector function = peak</li> <li>- Trace = max hold</li> <li>- Allow trace to fully stabilize.</li> <li>- It may prove necessary to break the span up to sections, in order to clearly show all of the hopping frequencies. The limit is specified in one of the subparagraphs of this Section. Submit this plot(s).</li> </ul>		
Remark			
Result	<input checked="" type="checkbox"/> Pass <input type="checkbox"/> Fail		

Test Data     Yes                       N/A  
 Test Plot     Yes (See below)                       N/A

### Number of Hopping Channel measurement result

Type	Modulation	Frequency Range	Number of Hopping Channel	Limit
Number of Hopping Channel	GFSK	2400-2483.5	79	15
	$\pi/4$ DQPSK	2400-2483.5	79	15
	8-DPSK	2400-2483.5	79	15

### Test Plots

#### Number of Hopping Channels measurement result

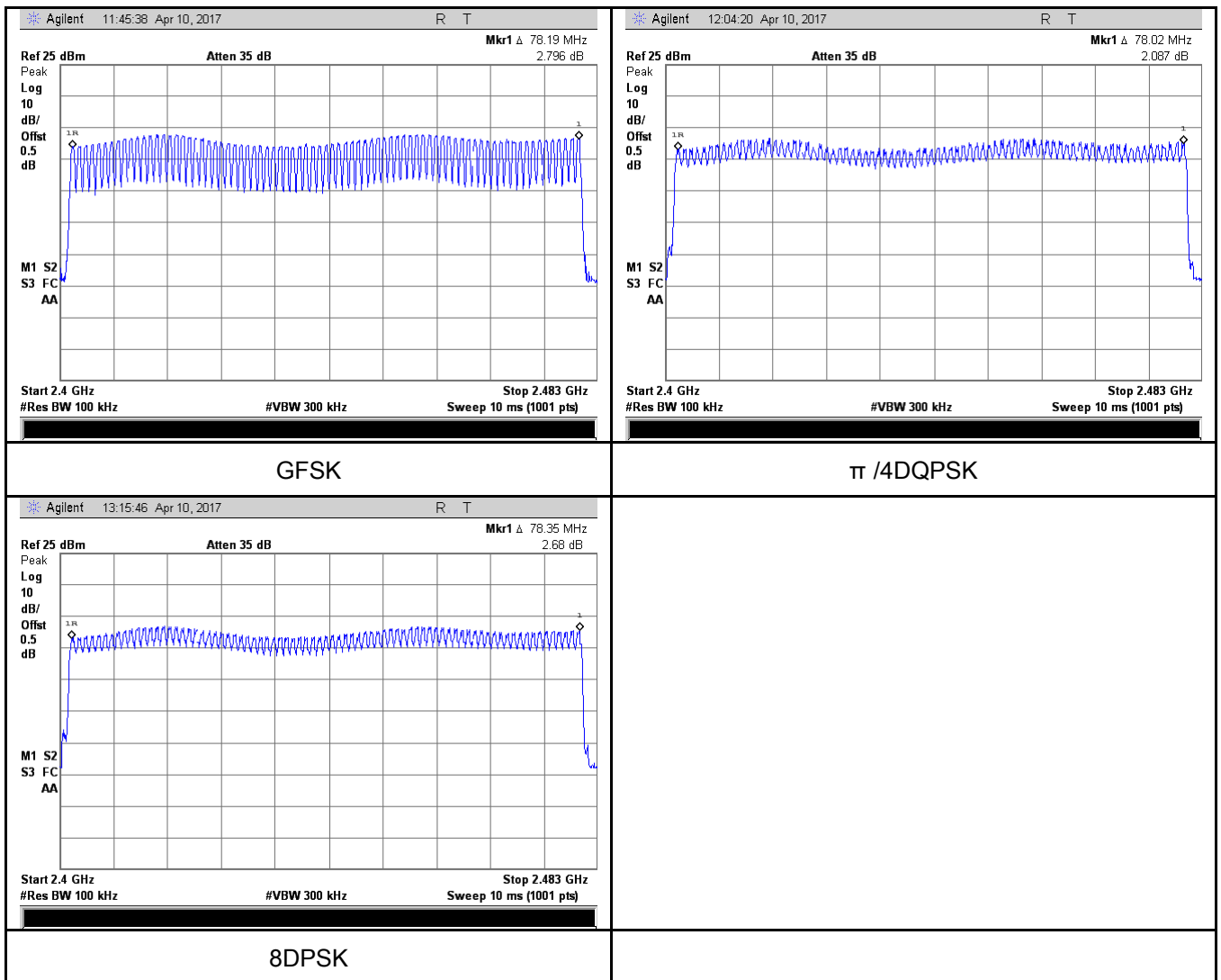

## 6.6 Time of Occupancy (Dwell Time)

Temperature	24°C
Relative Humidity	52%
Atmospheric Pressure	1007mbar
Test date :	April 10, 2017
Tested By :	Loren Luo

### Requirement(s):

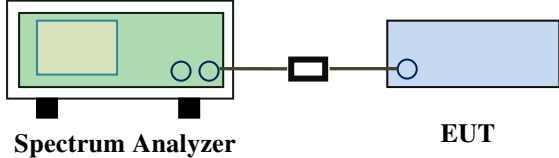
Spec	Item	Requirement	Applicable
§15.247(a) (1)(iii)	a)	Dwell Time < 0.4s	<input checked="" type="checkbox"/>
Test Setup	 <p style="text-align: center;">Spectrum Analyzer                      EUT</p>		
Test Procedure	<p>The test follows FCC Public Notice DA 00-705 Measurement Guidelines.  <u>Use the following spectrum analyzer</u></p> <ul style="list-style-type: none"> <li>- Span = zero span, centered on a hopping channel</li> <li>- RBW = 1 MHz</li> <li>- VBW ≥ RBW</li> <li>- Sweep = as necessary to capture the entire dwell time per hopping channel</li> <li>- Detector function = peak</li> <li>- use the marker-delta function to determine the dwell time</li> </ul>		
Remark			
Result	<input checked="" type="checkbox"/> Pass <input type="checkbox"/> Fail		

Test Data     Yes                       N/A

Test Plot     Yes (See below)                       N/A



**Dwell Time measurement result**

Type	Modulation	CH	Pulse Width (ms)	Dwell Time (ms)	Limit (ms)	Result
Dwell Time	GFSK	Low	2.91	310.400	400	Pass
		Mid	2.91	310.400	400	Pass
		High	2.91	310.400	400	Pass
	π /4 DQPSK	Low	2.94	313.600	400	Pass
		Mid	2.91	310.400	400	Pass
		High	2.91	310.400	400	Pass
	8-DPSK	Low	2.93	312.533	400	Pass
		Mid	2.91	310.400	400	Pass
		High	2.92	311.467	400	Pass
Note: Dwell time=Pulse Time (ms) × (1600 ÷ 6 ÷ 79) ×31.6						

### Test Plots

#### Dwell Time measurement result

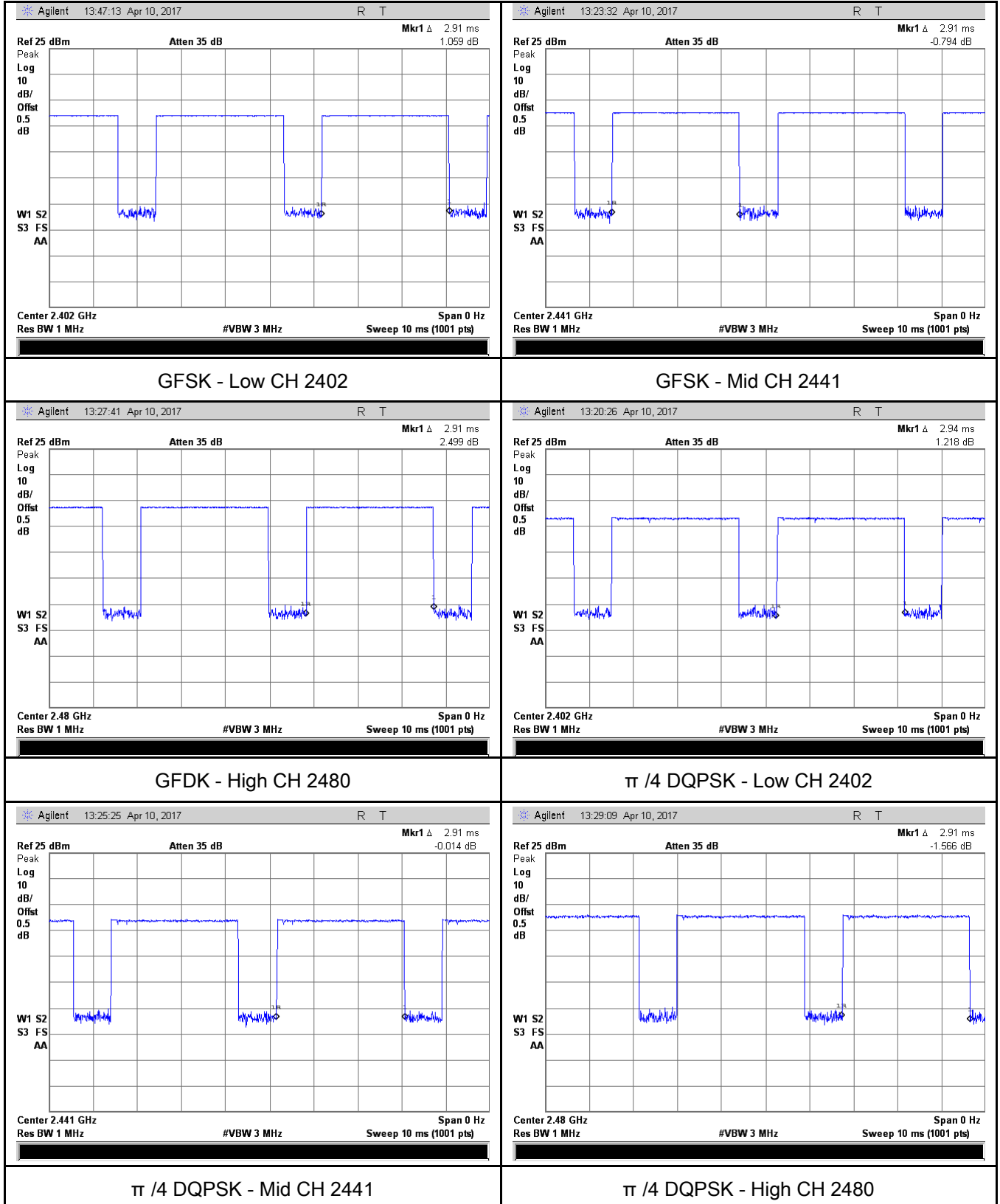

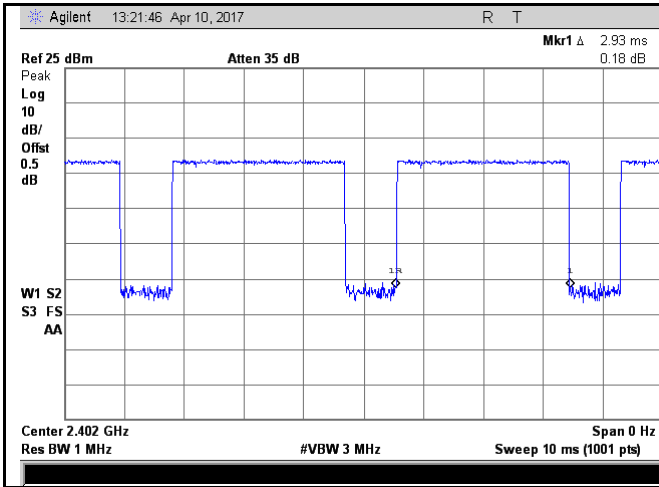

8DPSK - Low CH 2402

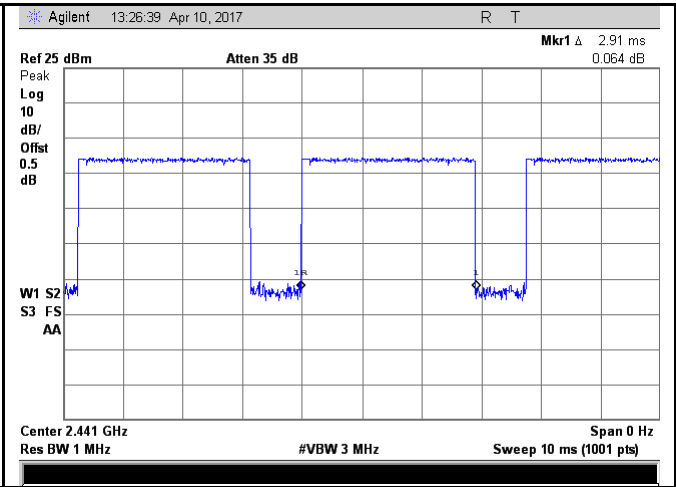

8DPSK - Mid CH 2441

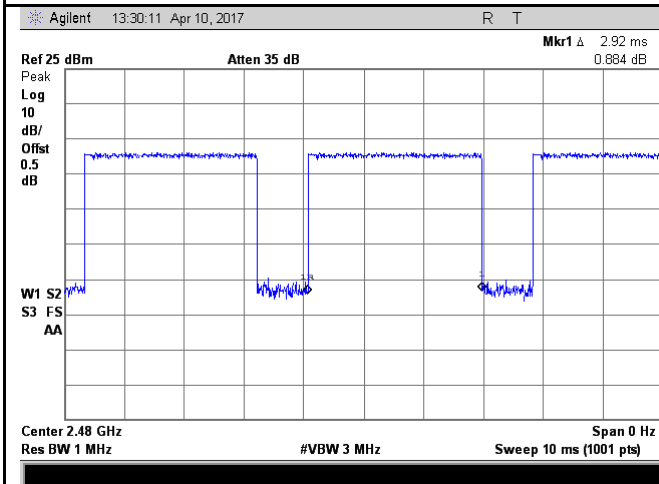

8DPSK - High CH 2480

## 6.7 Band Edge & Restricted Band

Temperature	25°C
Relative Humidity	55%
Atmospheric Pressure	1023mbar
Test date :	March 29, 2017
Tested By :	Loren Luo

### Requirement(s):

Spec	Item	Requirement	Applicable
§15.247(a) (1)(iii)	a)	In any 100 kHz bandwidth outside the frequency band in which the spread spectrum or digitally modulated intentional radiator is operating, the radio frequency power that is produced by the intentional radiator shall be at least 20 dB below that in the 100 kHz bandwidth within the band that contains the highest level of the desired power, based on either an RF conducted or a radiated measurement, provided the transmitter demonstrates compliance with the peak conducted power limits.	<input checked="" type="checkbox"/>

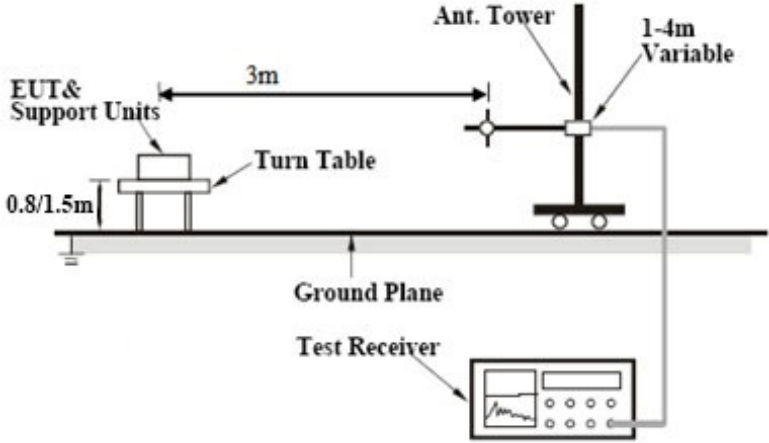
Test Setup	
------------	--

Test Procedure	<p>The test follows FCC Public Notice DA 00-705 Measurement Guidelines. Radiated Method Only</p> <ul style="list-style-type: none"> <li>- 1. Check the calibration of the measuring instrument using either an internal calibrator or a known signal from an external generator.</li> <li>- 2. Position the EUT without connection to measurement instrument. Put it on the Rotated table and turn on the EUT and make it operate in transmitting mode. Then set it to Low Channel and High Channel within its operating range,</li> </ul>
----------------	--

	<p>and make sure the instrument is operated in its linear range.</p> <ul style="list-style-type: none"> <li>- 3. First, set both RBW and VBW of spectrum analyzer to 100 kHz with a convenient frequency span including 100kHz bandwidth from band edge, check the emission of EUT, if pass then set Spectrum Analyzer as below: <ul style="list-style-type: none"> <li>a. The resolution bandwidth and video bandwidth of test receiver/spectrum analyzer is 120 kHz for Quasiy Peak detection at frequency below 1GHz.</li> <li>b. The resolution bandwidth of test receiver/spectrum analyzer is 1MHz and video bandwidth is 3MHz with Peak detection for Peak measurement at frequency above 1GHz.</li> <li>c. The resolution bandwidth of test receiver/spectrum analyzer is 1MHz and the video bandwidth is 10Hz with Peak detection for Average Measurement as below at frequency above 1GHz.</li> </ul> </li> <li>- 4. Measure the highest amplitude appearing on spectral display and set it as a reference level. Plot the graph with marking the highest point and edge frequency.</li> <li>- 5. Repeat above procedures until all measured frequencies were complete.</li> </ul>
Remark	
Result	<input checked="" type="checkbox"/> Pass <input type="checkbox"/> Fail

**Test Data**     Yes                       N/A  
**Test Plot**     Yes (See below)       N/A

### Test Plots

#### GFSK Mode:

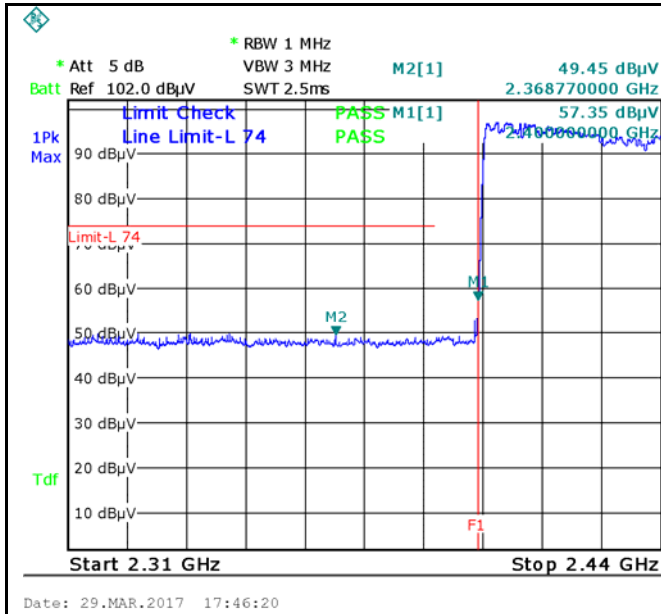

GFSK-Hopping Left Side-PK  
 Note: F1 is frequency 2400MHz

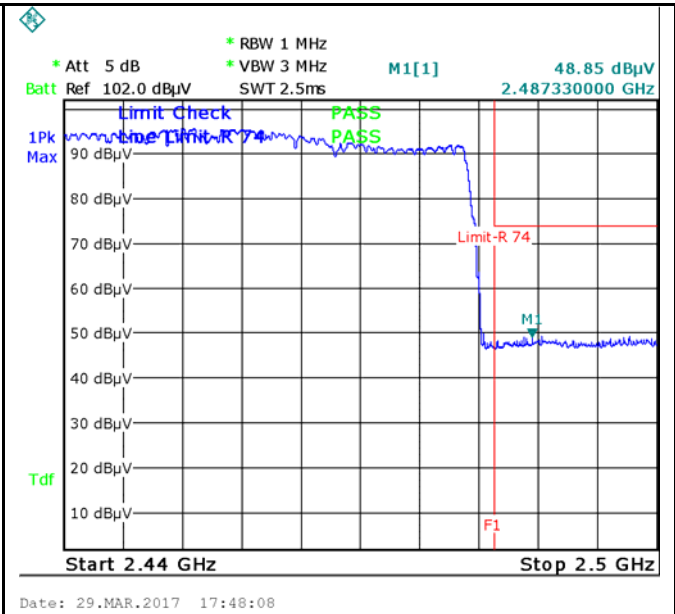

GFSK-Hopping Right Side-PK  
 Note: F1 is frequency 2483.5MHz

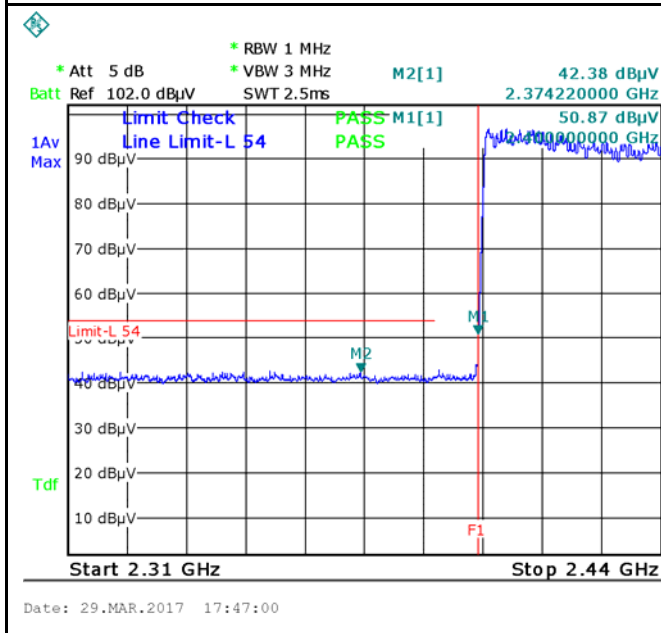

GFSK-Hopping Left Side-AV

Note: (no need if PK value less than the AV limit)

GFSK-Hopping Right Side-AV

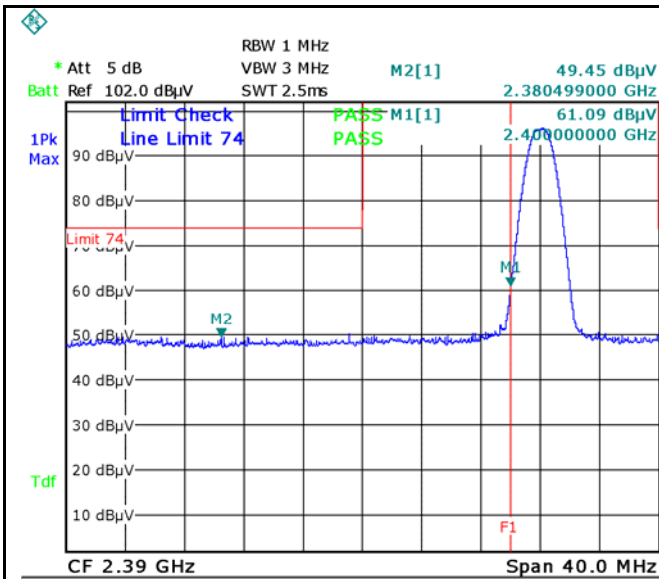

Date: 29.MAR.2017 17:25:34

GFSK-Left Side-PK

Note: F1 is frequency 2400MHz

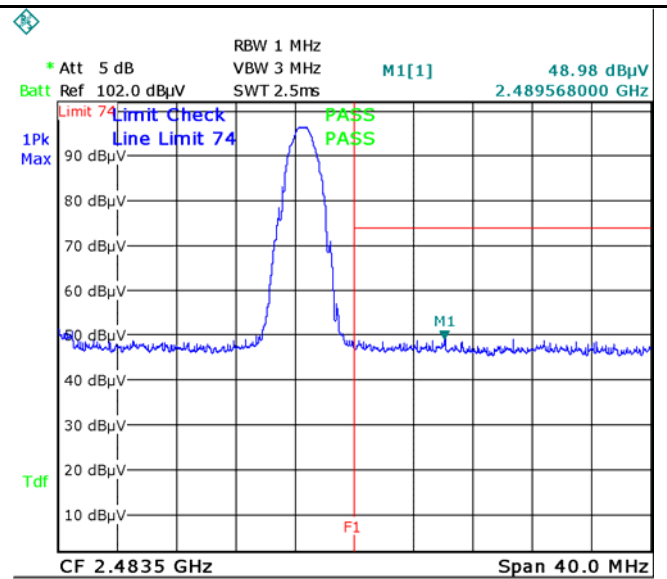

Date: 29.MAR.2017 17:36:52

GFSK-Right Side-PK

Note: F1 is frequency 2483.5MHz

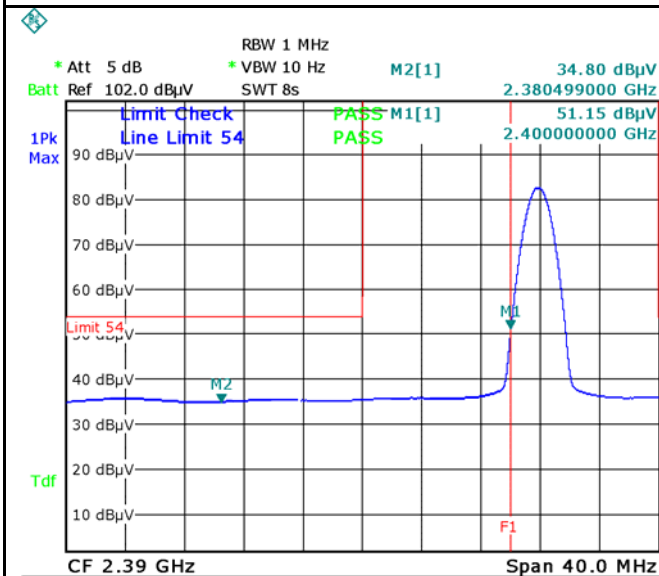

Date: 29.MAR.2017 17:26:26

GFSK-Left Side-AV

Note: (no need if PK value less than the AV limit)

GFSK-Right Side-AV

$\pi$  / 4 DQPSK Mode:

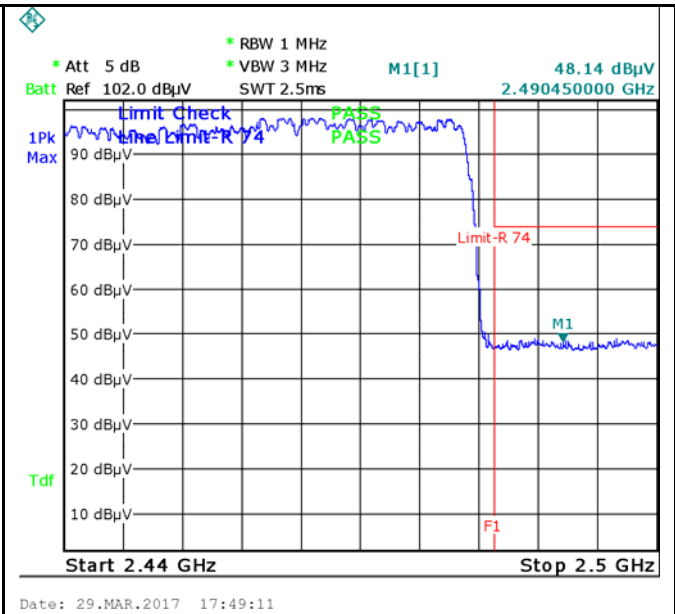
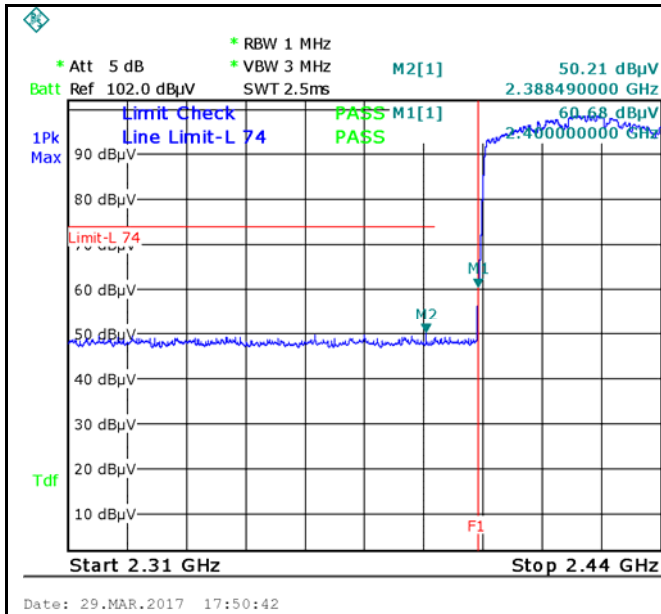

$\pi$  / 4 DQPSK-Hopping Left Side-PK

Note: F1 is frequency 2400MHz

$\pi$  / 4 DQPSK-Hopping Right Side-PK

Note: F1 is frequency 2483.5MHz

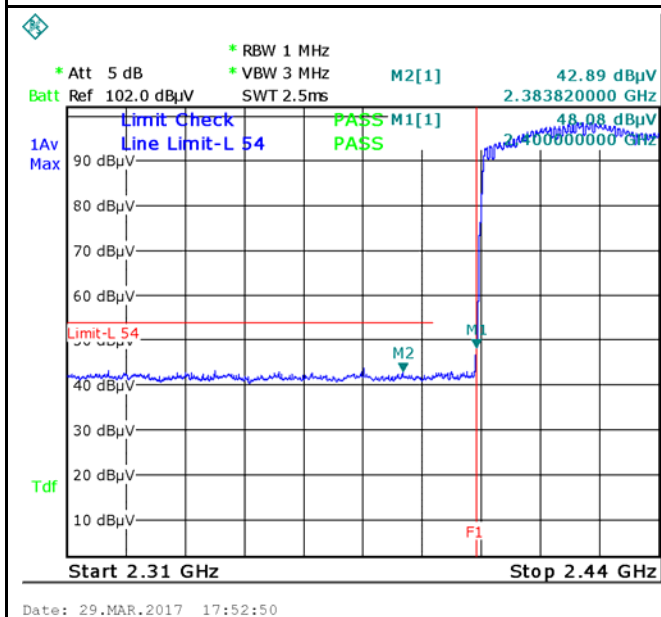

Note: (no need if PK value less than the AV limit)

$\pi$  / 4 DQPSK-Hopping Left-AV

$\pi$  / 4 DQPSK-Hopping Right-AV



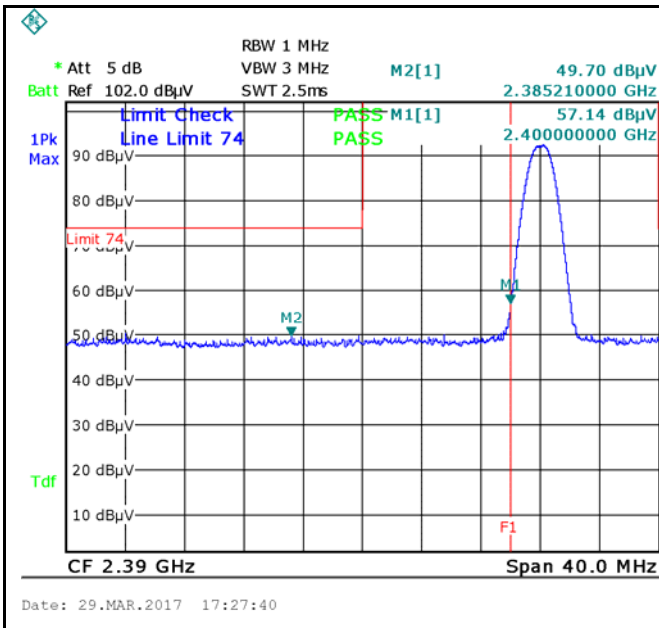

$\pi$  / 4 DQPSK-Left Side-PK

Note: F1 is frequency 2400MHz

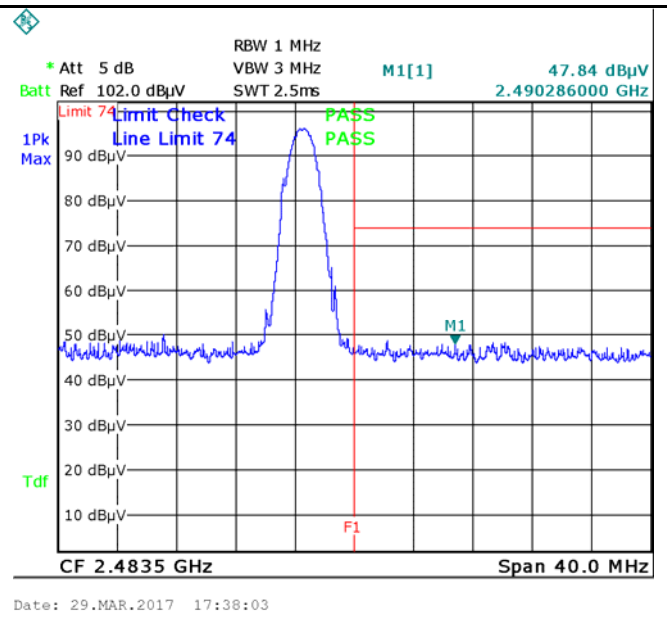

$\pi$  / 4 DQPSK-Right Side-PK

Note: F1 is frequency 2483.5MHz

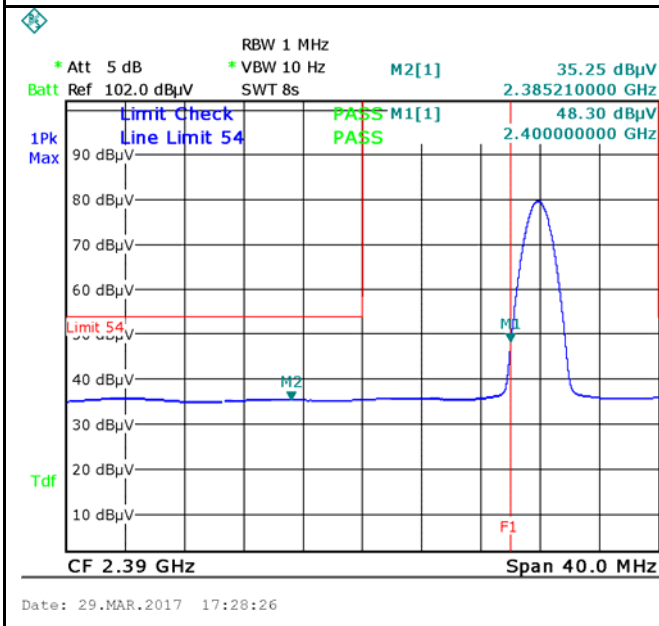

$\pi$  / 4 DQPSK-Left Side-AV

Note: (no need if PK value less than the AV limit)

$\pi$  / 4 DQPSK-Right Side-AV

**8-DPSK Mode:**

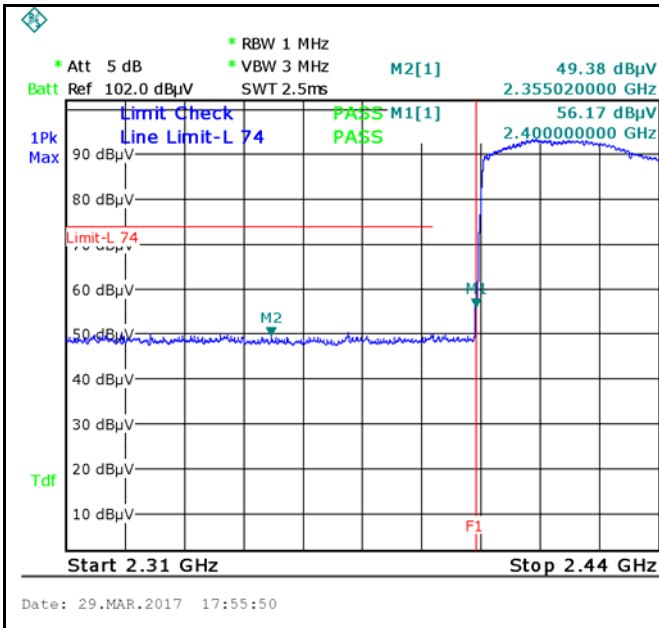

8DPSK-Hopping Left Side-PK

Note: F1 is frequency 2400MHz

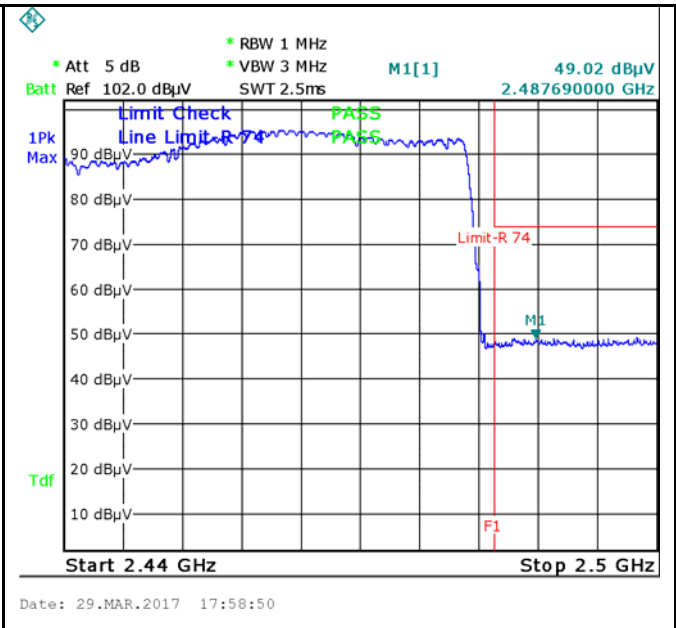

8DPSK-Hopping Right Side-PK

Note: F1 is frequency 2483.5MHz

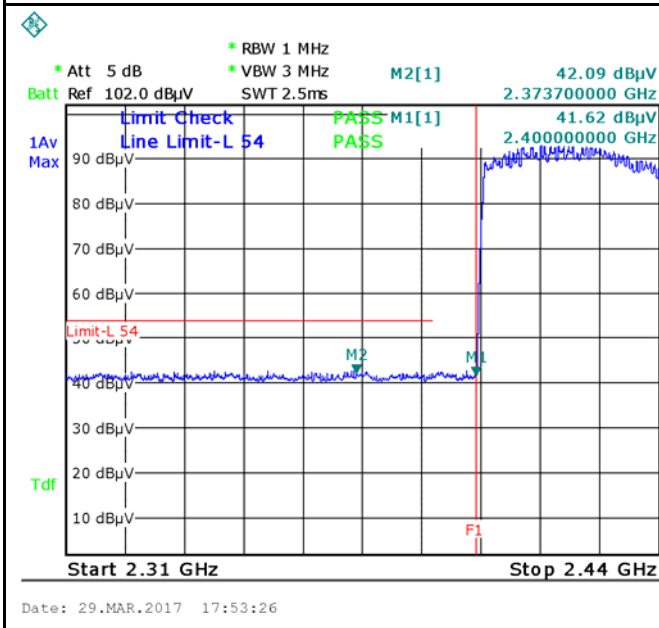

8DPSK-Hopping Left-AV

Note: (no need if PK value less than the AV limit)

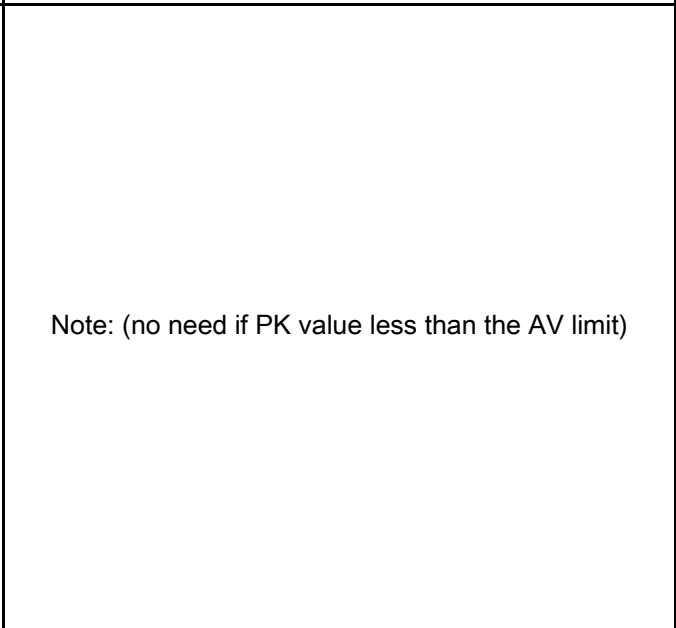

8DPSK-Hopping Right-AV

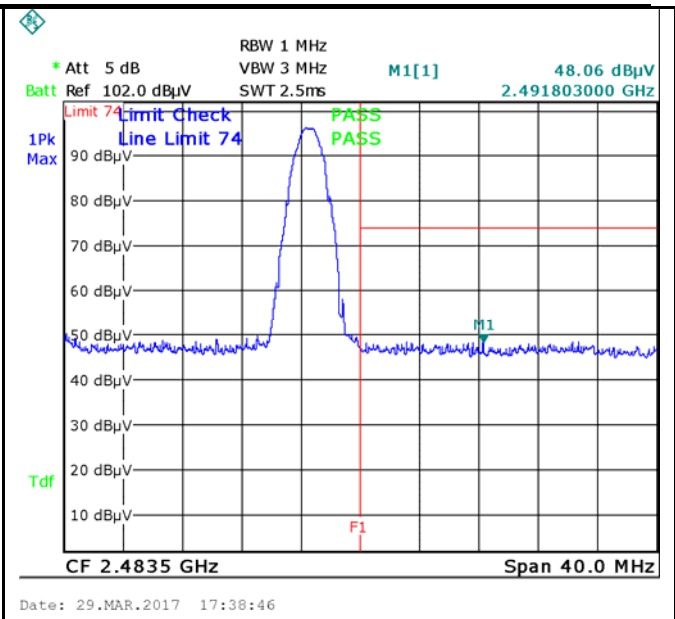
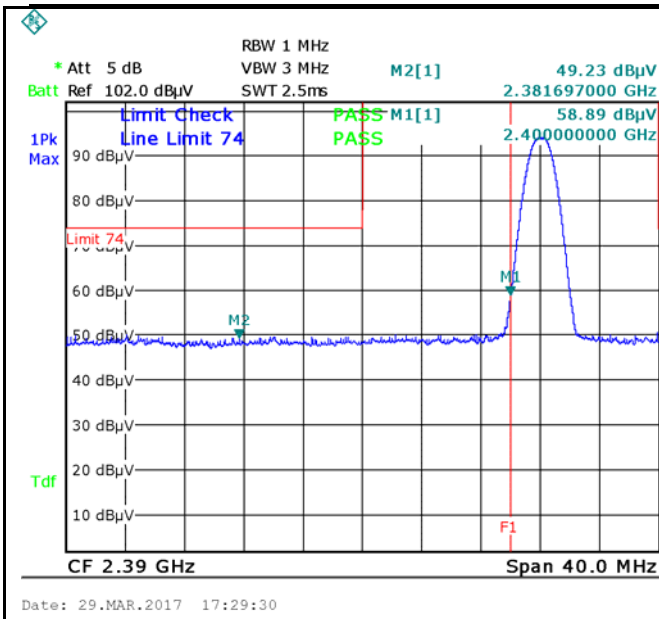

8DPSK-Left Side-PK

Note: F1 is frequency 2400MHz

8DPSK-Right Side-PK

Note: F1 is frequency 2483.5MHz

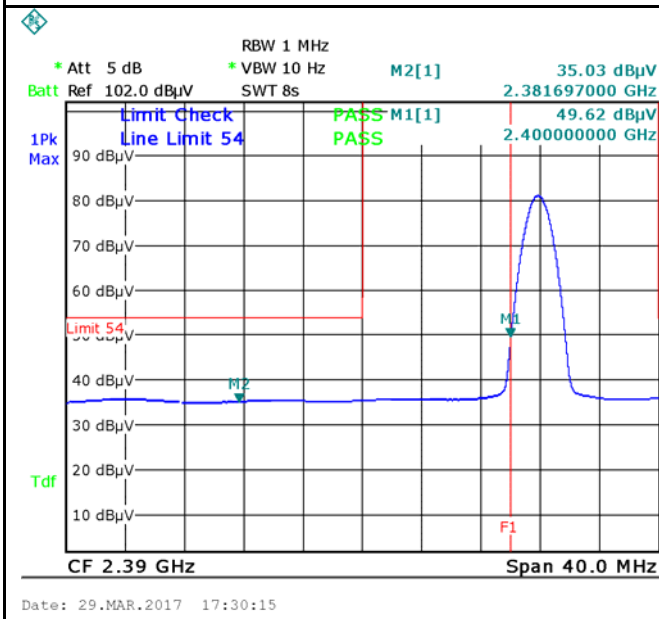

Note: (no need if PK value less than the AV limit)

8DPSK-Left Side-AV

8DPSK-Right Side-AV

## 6.8 AC Power Line Conducted Emissions

Temperature	25°C
Relative Humidity	55%
Atmospheric Pressure	1023mbar
Test date :	Marfh 29, 2017
Tested By :	Loren Luo

### Requirement(s):

Spec	Item	Requirement	Applicable														
47CFR§15.207, RSS210 (A8.1)	a)	For Low-power radio-frequency devices that is designed to be connected to the public utility (AC) power line, the radio frequency voltage that is conducted back onto the AC power line on any frequency or frequencies, within the band 150 kHz to 30 MHz, shall not exceed the limits in the following table, as measured using a 50 [mu]H/50 ohms line impedance stabilization network (LISN). The lower limit applies at the boundary between the frequencies ranges.	<input checked="" type="checkbox"/>														
		<table border="1"> <thead> <tr> <th rowspan="2">Frequency ranges (MHz)</th> <th colspan="2">Limit (dBµV)</th> </tr> <tr> <th>QP</th> <th>Average</th> </tr> </thead> <tbody> <tr> <td>0.15 ~ 0.5</td> <td>66 – 56</td> <td>56 – 46</td> </tr> <tr> <td>0.5 ~ 5</td> <td>56</td> <td>46</td> </tr> <tr> <td>5 ~ 30</td> <td>60</td> <td>50</td> </tr> </tbody> </table>		Frequency ranges (MHz)	Limit (dBµV)		QP	Average	0.15 ~ 0.5	66 – 56	56 – 46	0.5 ~ 5	56	46	5 ~ 30	60	50
		Frequency ranges (MHz)			Limit (dBµV)												
				QP	Average												
0.15 ~ 0.5	66 – 56	56 – 46															
0.5 ~ 5	56	46															
5 ~ 30	60	50															

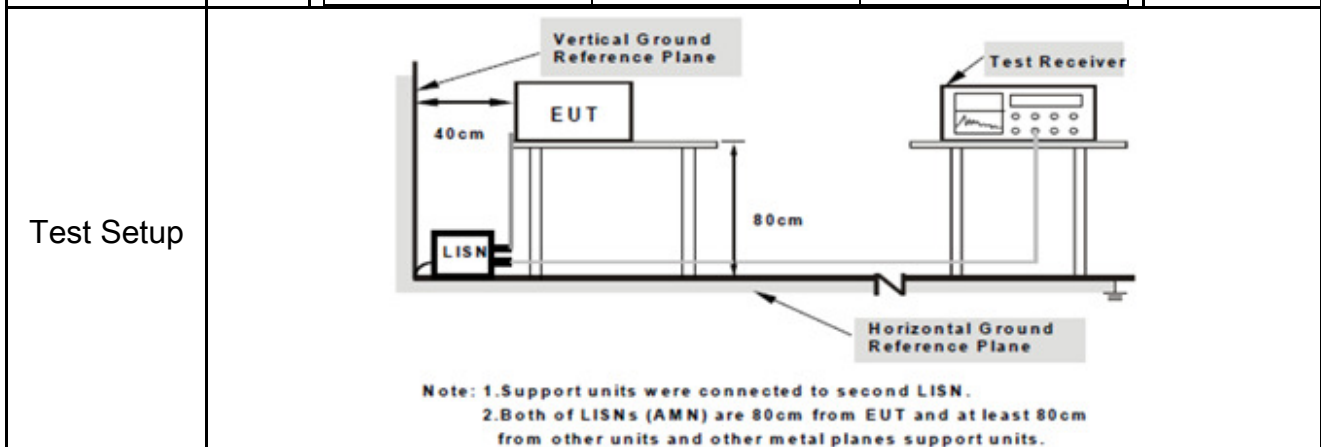

Procedure	<ol style="list-style-type: none"> <li>The EUT and supporting equipment were set up in accordance with the requirements of the standard on top of a 1.5m x 1m x 0.8m high, non-metallic table.</li> <li>The power supply for the EUT was fed through a 50W/50mH EUT LISN, connected to filtered mains.</li> <li>The RF OUT of the EUT LISN was connected to the EMI test receiver via a low-loss</li> </ol>
-----------	---

	<p>coaxial cable.</p> <ol style="list-style-type: none"> <li>4. All other supporting equipment were powered separately from another main supply.</li> <li>5. The EUT was switched on and allowed to warm up to its normal operating condition.</li> <li>6. A scan was made on the NEUTRAL line (for AC mains) or Earth line (for DC power) over the required frequency range using an EMI test receiver.</li> <li>7. High peaks, relative to the limit line, The EMI test receiver was then tuned to the selected frequencies and the necessary measurements made with a receiver bandwidth setting of 10 kHz.</li> <li>8. Step 7 was then repeated for the LIVE line (for AC mains) or DC line (for DC power).</li> </ol>
Remark	
Result	<input checked="" type="checkbox"/> Pass <input type="checkbox"/> Fail

Test Data     Yes                       N/A

Test Plot     Yes (See below)             N/A

<b>Test Mode:</b>	<b>Bluetooth Mode</b>
-------------------	-----------------------

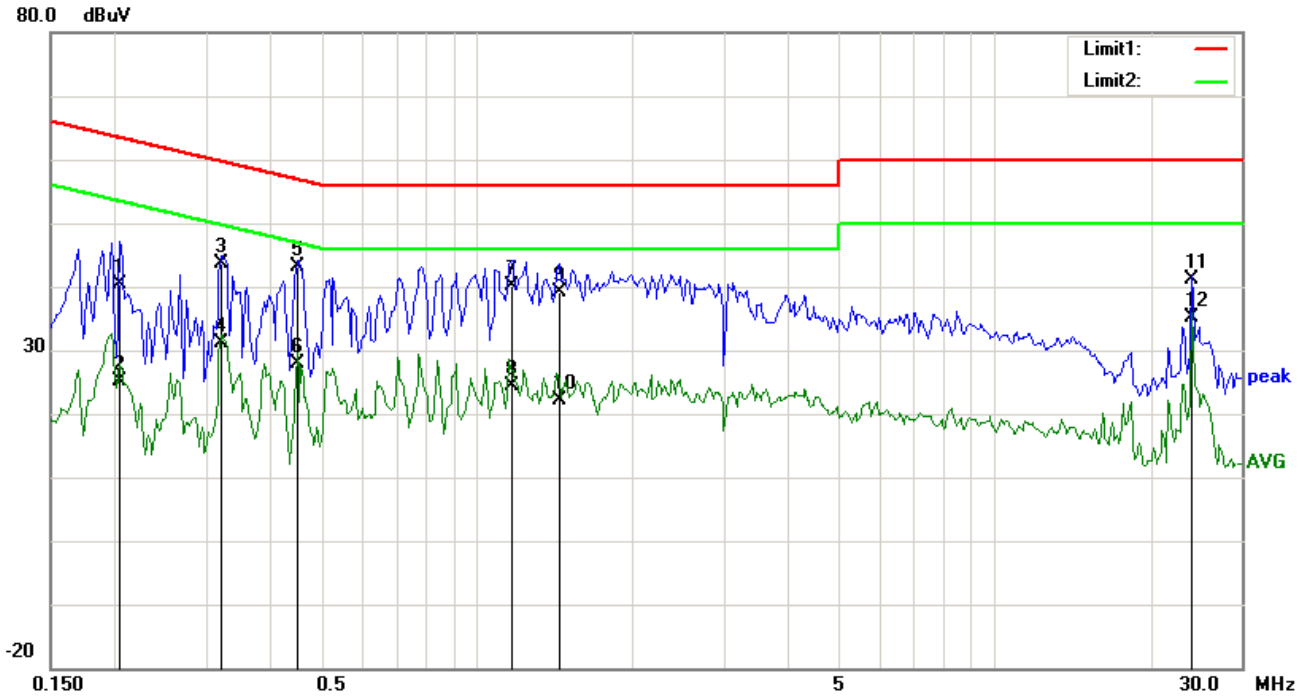

**Test Data**

**Phase Line Plot at 120Vac, 60Hz**

No.	P/L	Frequency	Reading	Detector	Corrected	Result	Limit	Margin
		(MHz)	(dBuV)		(dB)	(dBuV)	(dBuV)	(dB)
1	L1	0.2046	30.29	QP	10.03	40.32	63.42	-23.10
2	L1	0.2046	15.10	AVG	10.03	25.13	53.42	-28.29
3	L1	0.3216	33.62	QP	10.03	43.65	59.67	-16.02
4	L1	0.3216	21.21	AVG	10.03	31.24	49.67	-18.43
5	L1	0.4503	33.12	QP	10.03	43.15	56.87	-13.72
6	L1	0.4503	17.76	AVG	10.03	27.79	46.87	-19.08
7	L1	1.1718	30.21	QP	10.03	40.24	56.00	-15.76
8	L1	1.1718	14.37	AVG	10.03	24.40	46.00	-21.60
9	L1	1.4409	29.09	QP	10.04	39.13	56.00	-16.87
10	L1	1.4409	12.11	AVG	10.04	22.15	46.00	-23.85
11	L1	24.0249	30.72	QP	10.38	41.10	60.00	-18.90
12	L1	24.0249	24.68	AVG	10.38	35.06	50.00	-14.94

<b>Test Mode:</b>	<b>Bluetooth Mode</b>
-------------------	-----------------------

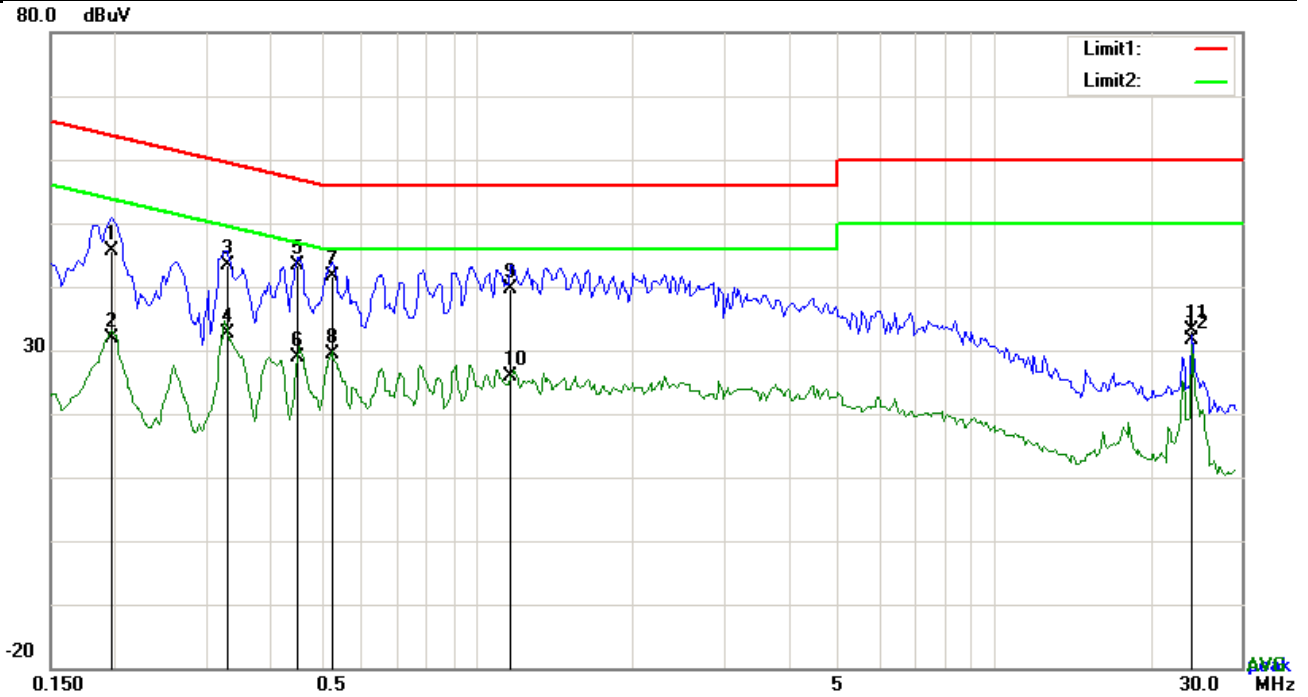

**Test Data**

**Phase Neutral Plot at 120Vac, 60Hz**

No.	P/L	Frequency	Reading	Detector	Corrected	Result	Limit	Margin
		(MHz)	(dBuV)		(dB)	(dBuV)	(dBuV)	(dB)
1	N	0.1968	35.71	QP	10.02	45.73	63.74	-18.01
2	N	0.1968	21.79	AVG	10.02	31.81	53.74	-21.93
3	N	0.3294	33.44	QP	10.02	43.46	59.47	-16.01
4	N	0.3294	22.64	AVG	10.02	32.66	49.47	-16.81
5	N	0.4503	33.43	QP	10.02	43.45	56.87	-13.42
6	N	0.4503	18.93	AVG	10.02	28.95	46.87	-17.92
7	N	0.5244	31.66	QP	10.02	41.68	56.00	-14.32
8	N	0.5244	19.47	AVG	10.02	29.49	46.00	-16.51
9	N	1.1640	29.58	QP	10.03	39.61	56.00	-16.39
10	N	1.1640	15.90	AVG	10.03	25.93	46.00	-20.07
11	N	24.0249	22.76	QP	10.32	33.08	60.00	-26.92
12	N	24.0249	21.37	AVG	10.32	31.69	50.00	-18.31

<b>Test Mode:</b>	<b>Bluetooth Mode</b>
-------------------	-----------------------

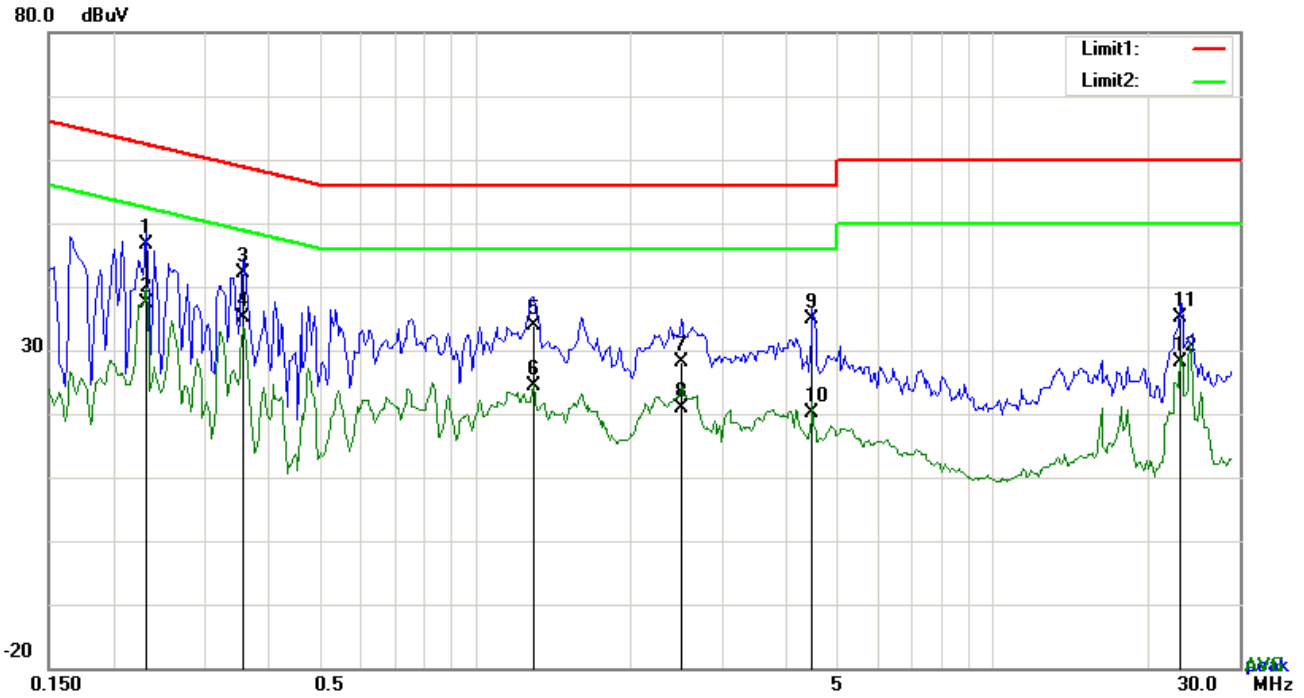

**Test Data**

**Phase Line Plot at 240Vac, 60Hz**

No.	P/L	Frequency	Reading	Detector	Corrected	Result	Limit	Margin
		(MHz)	(dBuV)		(dB)	(dBuV)	(dBuV)	(dB)
1	L1	0.2319	36.50	QP	10.03	46.53	62.38	-15.85
2	L1	0.2319	27.47	AVG	10.03	37.50	52.38	-14.88
3	L1	0.3567	32.03	QP	10.03	42.06	58.80	-16.74
4	L1	0.3567	25.12	AVG	10.03	35.15	48.80	-13.65
5	L1	1.2966	23.77	QP	10.03	33.80	56.00	-22.20
6	L1	1.2966	14.25	AVG	10.03	24.28	46.00	-21.72
7	L1	2.5095	17.99	QP	10.05	28.04	56.00	-27.96
8	L1	2.5095	10.71	AVG	10.05	20.76	46.00	-25.24
9	L1	4.4937	24.74	QP	10.07	34.81	56.00	-21.19
10	L1	4.4937	10.11	AVG	10.07	20.18	46.00	-25.82
11	L1	23.1318	24.88	QP	10.36	35.24	60.00	-24.76
12	L1	23.1318	17.77	AVG	10.36	28.13	50.00	-21.87



<b>Test Mode:</b>	<b>Bluetooth Mode</b>
-------------------	-----------------------

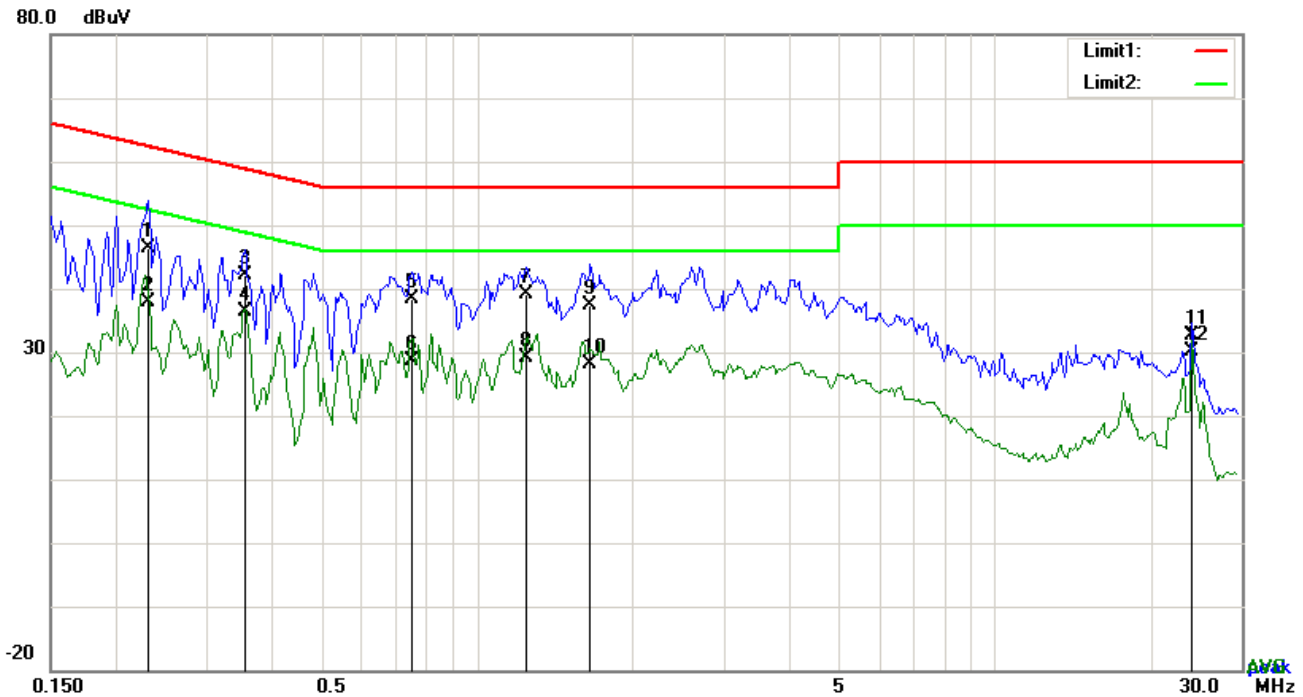

**Test Data**

**Phase Neutral Plot at 240Vac, 60Hz**

No.	P/L	Frequency	Reading	Detector	Corrected	Result	Limit	Margin
		(MHz)	(dBuV)		(dB)	(dBuV)	(dBuV)	(dB)
1	N	0.2319	36.35	QP	10.02	46.37	62.38	-16.01
2	N	0.2319	27.90	AVG	10.02	37.92	52.38	-14.46
3	N	0.3567	32.06	QP	10.02	42.08	58.80	-16.72
4	N	0.3567	26.39	AVG	10.02	36.41	48.80	-12.39
5	N	0.7506	28.27	QP	10.03	38.30	56.00	-17.70
6	N	0.7506	18.51	AVG	10.03	28.54	46.00	-17.46
7	N	1.2459	29.00	QP	10.03	39.03	56.00	-16.97
8	N	1.2459	18.99	AVG	10.03	29.02	46.00	-16.98
9	N	1.6593	27.40	QP	10.04	37.44	56.00	-18.56
10	N	1.6593	17.99	AVG	10.04	28.03	46.00	-17.97
11	N	24.0249	22.19	QP	10.32	32.51	60.00	-27.49
12	N	24.0249	19.72	AVG	10.32	30.04	50.00	-19.96

## 6.9 Radiated Emissions & Restricted Band

Temperature	25°C
Relative Humidity	55%
Atmospheric Pressure	1023mbar
Test date :	March 29, 2017
Tested By :	Loren Luo

### Requirement(s):

Spec	Item	Requirement	Applicable										
47CFR§15.205, §15.209, §15.247(d)	a)	<p>Except higher limit as specified elsewhere in other section, the emissions from the low-power radio-frequency devices shall not exceed the field strength levels specified in the following table and the level of any unwanted emissions shall not exceed the level of the fundamental emission. The tighter limit applies at the band edges</p> <table border="1"> <thead> <tr> <th>Frequency range (MHz)</th> <th>Field Strength (µV/m)</th> </tr> </thead> <tbody> <tr> <td>30 – 88</td> <td>100</td> </tr> <tr> <td>88 – 216</td> <td>150</td> </tr> <tr> <td>216 - 960</td> <td>200</td> </tr> <tr> <td>Above 960</td> <td>500</td> </tr> </tbody> </table>	Frequency range (MHz)	Field Strength (µV/m)	30 – 88	100	88 – 216	150	216 - 960	200	Above 960	500	<input checked="" type="checkbox"/>
Frequency range (MHz)	Field Strength (µV/m)												
30 – 88	100												
88 – 216	150												
216 - 960	200												
Above 960	500												

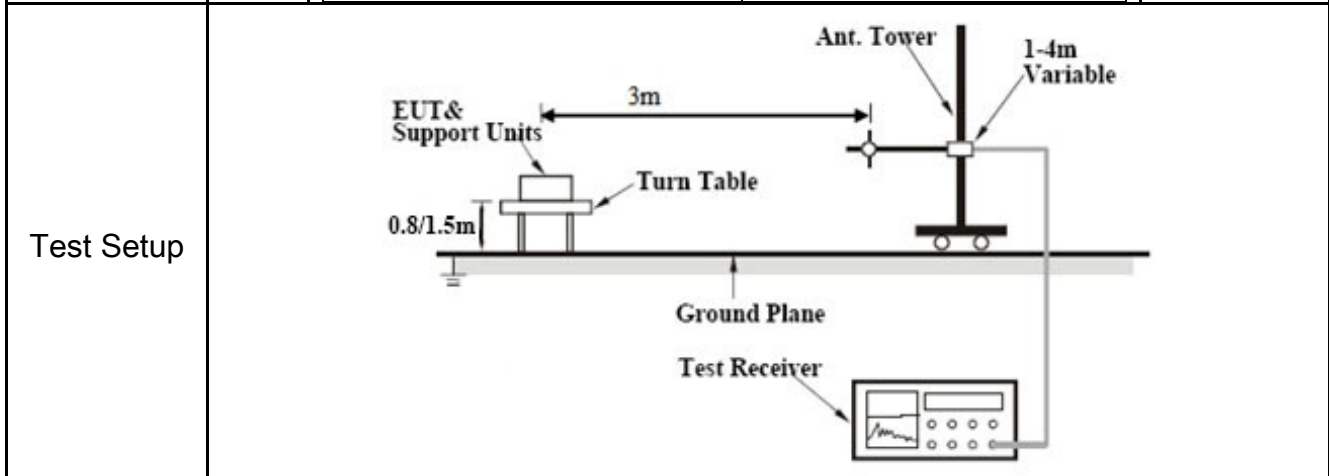

Procedure	<ol style="list-style-type: none"> <li>The EUT was switched on and allowed to warm up to its normal operating condition.</li> <li>The test was carried out at the selected frequency points obtained from the EUT characterization. Maximization of the emissions, was carried out by rotating the EUT, changing the antenna polarization, and adjusting the antenna height in the following manner:</li> </ol>
-----------	---

	<ol style="list-style-type: none"> <li>a. Vertical or horizontal polarization (whichever gave the higher emission level over a full rotation of the EUT) was chosen.</li> <li>b. The EUT was then rotated to the direction that gave the maximum emission.</li> <li>c. Finally, the antenna height was adjusted to the height that gave the maximum emission.</li> </ol> <ol style="list-style-type: none"> <li>3. The resolution bandwidth and video bandwidth of test receiver/spectrum analyzer is 120 kHz for Quasiy Peak detection at frequency below 1GHz.</li> <li>4. The resolution bandwidth of test receiver/spectrum analyzer is 1MHz and video bandwidth is 3MHz with Peak detection for Peak measurement at frequency above 1GHz. The resolution bandwidth of test receiver/spectrum analyzer is 1MHz and the video bandwidth is 10Hz with Peak detection for Average Measurement as below at frequency above 1GHz.</li> <li>5. Steps 2 and 3 were repeated for the next frequency point, until all selected frequency points were measured.</li> </ol>
Remark	
Result	<input checked="" type="checkbox"/> Pass <input type="checkbox"/> Fail

Test Data     Yes                       N/A  
 Test Plot     Yes (See below)             N/A

**Test Mode:** Bluetooth Mode

**Below 1GHz**

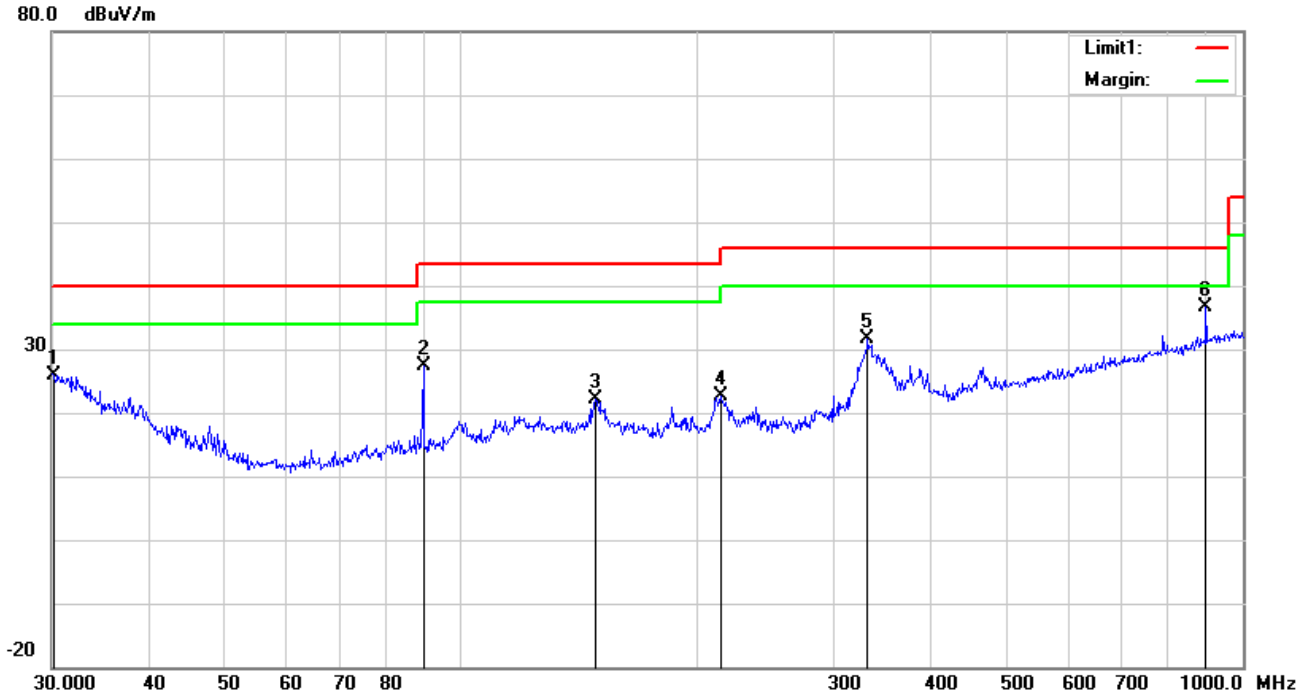

**Test Data**

**Horizontal Polarity Plot @3m**

No.	P/L	Frequency (MHz)	Reading (dBuV/m)	Detect or	Ant_F (dB/m)	PA_G (dB)	Cab_L (dB)	Result (dBuV/m)	Limit (dBuV/m)	Margin (dB)	Height (cm)	Degr ee (°)
1	H	30.2111	26.41	peak	21.24	22.28	0.63	26.00	40.00	-14.00	100	203
2	H	89.5900	40.79	peak	7.98	22.32	0.96	27.41	43.50	-16.09	100	38
3	H	148.4410	30.56	peak	12.60	22.35	1.33	22.14	43.50	-21.36	100	47
4	H	215.2678	31.39	peak	11.89	22.35	1.59	22.52	43.50	-20.98	100	351
5	H	331.3547	37.52	peak	14.26	22.20	1.95	31.53	46.00	-14.47	100	303
6	H	896.9965	32.08	peak	22.47	20.89	3.06	36.72	46.00	-9.28	100	134

**Below 1GHz**

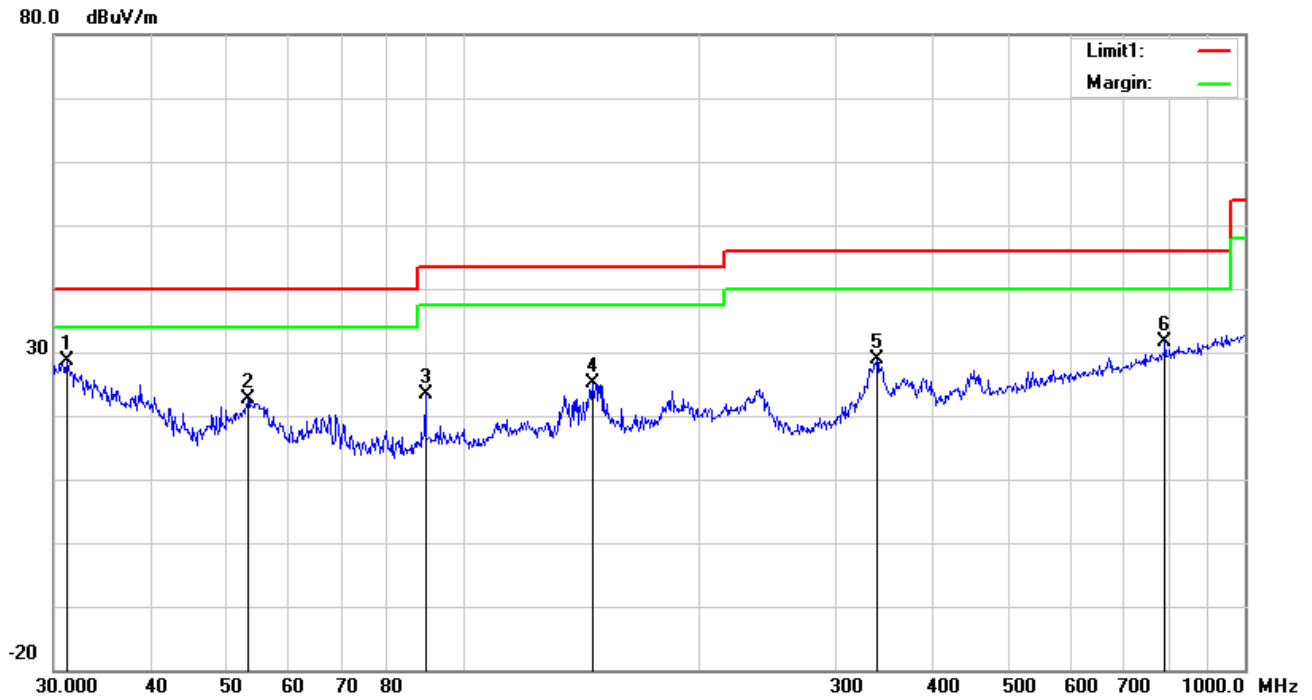

**Test Data**

**Vertical Polarity Plot @3m**

No.	P/L	Frequency (MHz)	Reading (dBuV/m)	Detect or	Ant_F (dB/m)	PA_G (dB)	Cab_L (dB)	Result (dBuV/m)	Limit (dBuV/m)	Margin (dB)	Height (cm)	Degr ee (°)
1	V	31.1798	29.68	peak	20.49	22.27	0.65	28.55	40.00	-11.45	100	14
2	V	53.1313	36.18	peak	8.06	22.39	0.79	22.64	40.00	-17.36	100	294
3	V	89.5900	36.81	peak	7.98	22.32	0.96	23.43	43.50	-20.07	100	330
4	V	146.3735	33.55	peak	12.60	22.37	1.31	25.09	43.50	-18.41	100	276
5	V	338.4001	34.74	peak	14.41	22.18	1.98	28.95	46.00	-17.05	100	116
6	V	790.6188	28.57	peak	21.29	21.17	2.94	31.63	46.00	-14.37	100	214

**Above 1GHz**

<b>Test Mode:</b>	<b>Transmitting Mode</b>
-------------------	--------------------------

**Low Channel: GFSK Mode (Worst Case) (2402 MHz)**

Frequency (MHz)	S.A. Reading (dBμV)	Detector (PK/AV)	Polarity (H/V)	Ant. Factor (dB/m)	Cable Loss (dB)	Pre-Amp. Gain (dB)	Cord. Amp. (dBμV/m)	Limit (dBμV/m)	Margin (dB)
4804	39.52	AV	V	33.67	6.86	32.66	47.39	54	-6.61
4804	39.23	AV	H	33.67	6.86	32.66	47.1	54	-6.9
4804	48.75	PK	V	33.67	6.86	32.66	56.62	74	-17.38
4804	46.22	PK	H	33.67	6.86	32.66	54.09	74	-19.91
17801	24.7	AV	V	45.03	11.21	32.38	48.56	54	-5.44
17801	24.69	AV	H	45.03	11.21	32.38	48.55	54	-5.45
17801	39.92	PK	V	45.03	11.21	32.38	63.78	74	-10.22
17801	42.24	PK	H	45.03	11.21	32.38	66.1	74	-7.9

**Middle Channel: GFSK Mode (Worst Case) (2441 MHz)**

Frequency (MHz)	S.A. Reading (dBμV)	Detector (PK/AV)	Polarity (H/V)	Ant. Factor (dB/m)	Cable Loss (dB)	Pre-Amp. Gain (dB)	Cord. Amp. (dBμV/m)	Limit (dBμV/m)	Margin (dB)
4882	38.79	AV	V	33.71	6.95	32.74	46.71	54	-7.29
4882	38.89	AV	H	33.71	6.95	32.74	46.81	54	-7.19
4882	48.91	PK	V	33.71	6.95	32.74	56.83	74	-17.17
4882	47.16	PK	H	33.71	6.95	32.74	55.08	74	-18.92
17807	25.67	AV	V	45.15	11.18	32.41	49.59	54	-4.41
17807	23.82	AV	H	45.15	11.18	32.41	47.74	54	-6.26
17807	40.9	PK	V	45.15	11.18	32.41	64.82	74	-9.18
17807	41.28	PK	H	45.15	11.18	32.41	65.2	74	-8.80

**High Channel: GFSK Mode (Worst Case) (2480 MHz)**

Frequency (MHz)	S.A. Reading (dB $\mu$ V)	Detector (PK/AV)	Polarity (H/V)	Ant. Factor (dB/m)	Cable Loss (dB)	Pre-Amp. Gain (dB)	Cord. Amp. (dB $\mu$ V/m)	Limit (dB $\mu$ V/m)	Margin (dB)
4960	36.63	AV	V	33.9	6.76	32.74	44.55	54	-9.45
4960	37.86	AV	H	33.9	6.76	32.74	45.78	54	-8.22
4960	47.93	PK	V	33.9	6.76	32.74	55.85	74	-18.15
4960	46.77	PK	H	33.9	6.76	32.74	54.69	74	-19.31
17822	23.89	AV	V	45.22	11.35	32.38	48.08	54	-5.92
17822	23.85	AV	H	45.22	11.35	32.38	48.04	54	-5.96
17822	42.38	PK	V	45.22	11.35	32.38	66.57	74	-7.43
17822	40.99	PK	H	45.22	11.35	32.38	65.18	74	-8.82

**Note:**

- 1, The testing has been conformed to  $10 \times 2480 \text{ MHz} = 24,800 \text{ MHz}$
- 2, All other emissions more than 30 dB below the limit
- 3, X-Axis, Y-Axis and Z-Axis were investigated. The results above show only the worst case.

## Annex A. TEST INSTRUMENT

Instrument	Model	Serial #	Cal Date	Cal Due	In use
<b>AC Line Conducted</b>					
EMI test receiver	ESCS30	8471241027	09/16/2016	09/15/2017	<input checked="" type="checkbox"/>
Line Impedance	LI-125A	191106	09/24/2016	09/23/2017	<input checked="" type="checkbox"/>
Line Impedance	LI-125A	191107	09/24/2016	09/23/2017	<input checked="" type="checkbox"/>
LISN	ISN T800	34373	09/24/2016	09/23/2017	<input checked="" type="checkbox"/>
Double Ridge Horn Antenna (1 ~18GHz)	AH-118	71283	09/23/2016	09/22/2017	<input checked="" type="checkbox"/>
Transient Limiter	LIT-153	531118	08/31/2016	08/30/2017	<input checked="" type="checkbox"/>
<b>RF conducted test</b>					
Agilent ESA-E SERIES	E4407B	MY45108319	09/16/2016	09/15/2017	<input checked="" type="checkbox"/>
Power Splitter	1#	1#	08/31/2016	08/30/2017	<input checked="" type="checkbox"/>
DC Power Supply	E3640A	MY40004013	09/16/2016	09/15/2017	<input checked="" type="checkbox"/>
<b>Radiated Emissions</b>					
EMI test receiver	ESL6	100262	09/16/2016	09/15/2017	<input checked="" type="checkbox"/>
Positioning Controller	UC3000	MF780208282	11/18/2016	11/17/2017	<input checked="" type="checkbox"/>
OPT 010 AMPLIFIER (0.1-1300MHz)	8447E	2727A02430	08/31/2016	08/30/2017	<input checked="" type="checkbox"/>
Microwave Preamplifier (1 ~ 26.5GHz)	8449B	3008A02402	03/23/2017	03/22/2018	<input checked="" type="checkbox"/>
Bilog Antenna (30MHz~6GHz)	JB6	A110712	09/20/2016	09/19/2017	<input checked="" type="checkbox"/>
Double Ridge Horn Antenna (1 ~18GHz)	AH-118	71283	09/23/2016	09/22/2017	<input checked="" type="checkbox"/>
Universal Radio Communication Tester	CMU200	121393	09/24/2016	09/23/2017	<input checked="" type="checkbox"/>



**Annex B. EUT And Test Setup Photographs**

**Annex B.i. Photograph: EUT External Photo**

Whole Package View



Adapter - Label View



EUT - Front View



EUT - Rear View





EUT - Top View



EUT - Bottom View

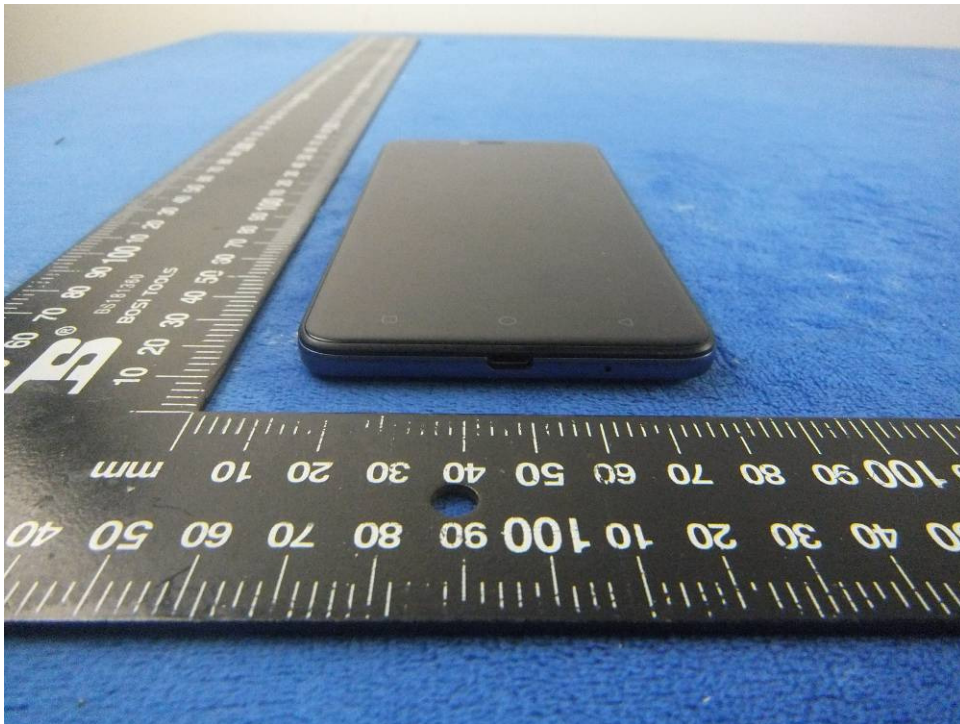

EUT - Left View



EUT - Right View





**Annex B.ii. Photograph: EUT Internal Photo**

Cover Off - Top View 1



Cover Off - Top View 2



Battery - Front View



Battery - Rear View





Mainboard with Shielding - Front View

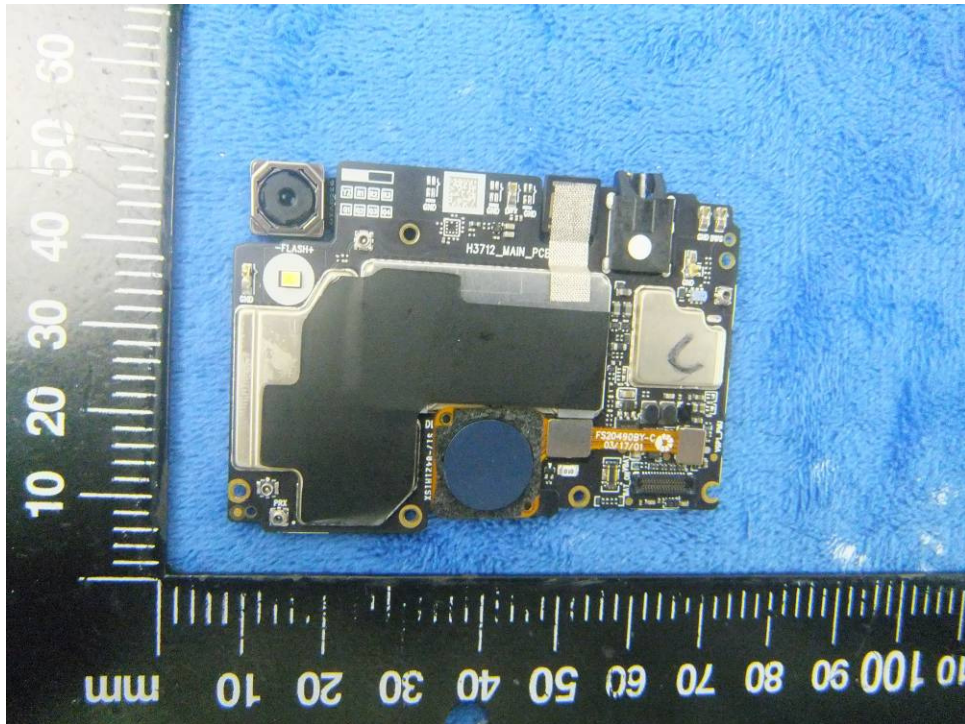

Mainboard without Shielding - Front View

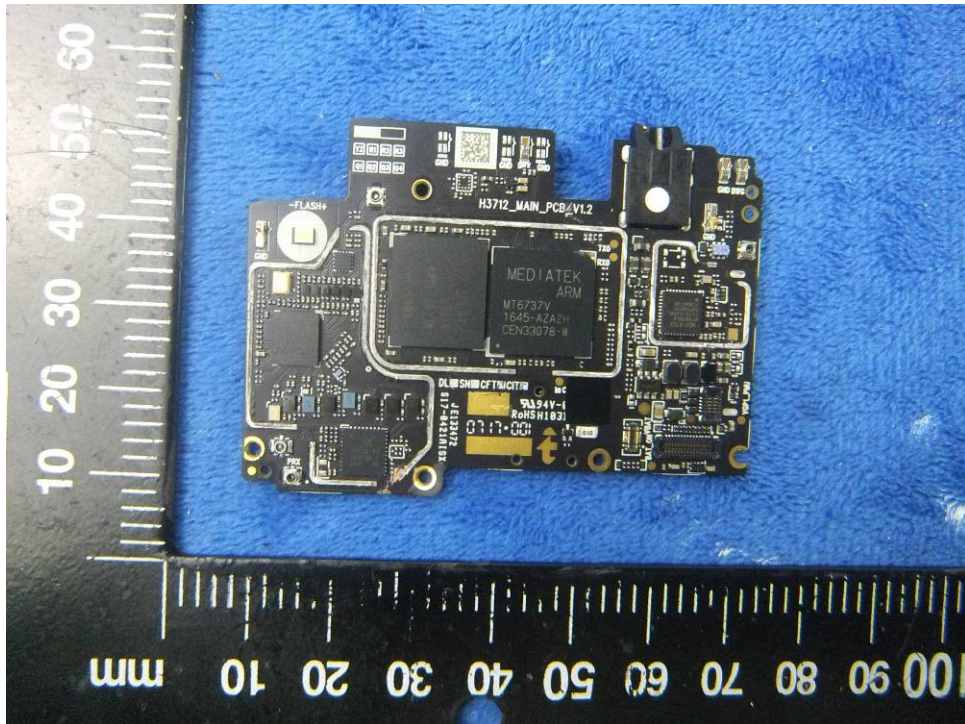



Mainboard with Shielding – Rear View

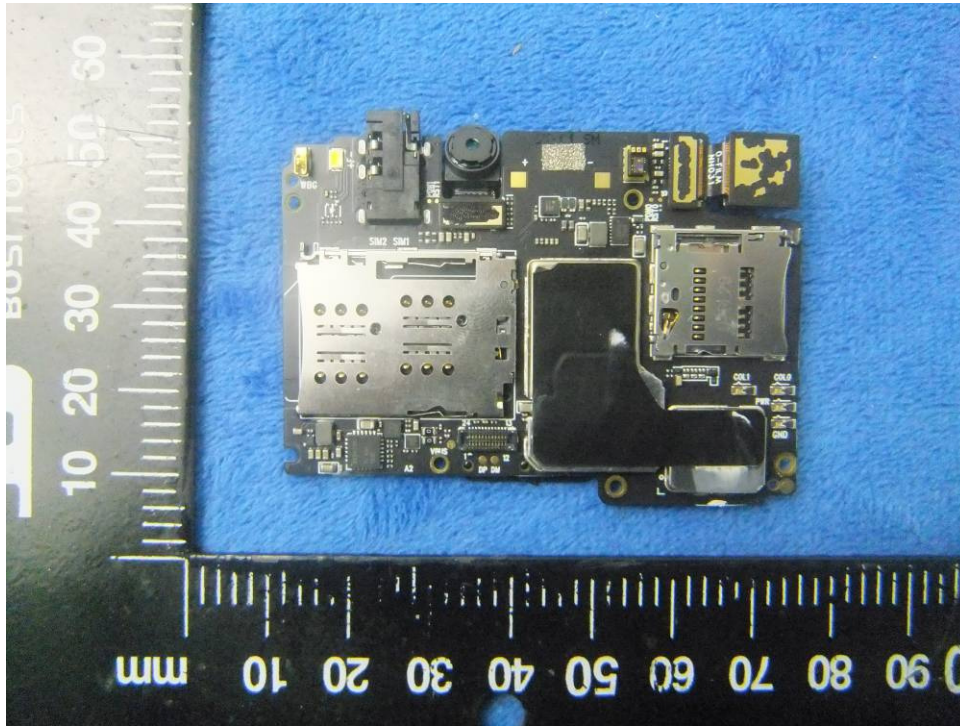

Mainboard without Shielding – Rear View

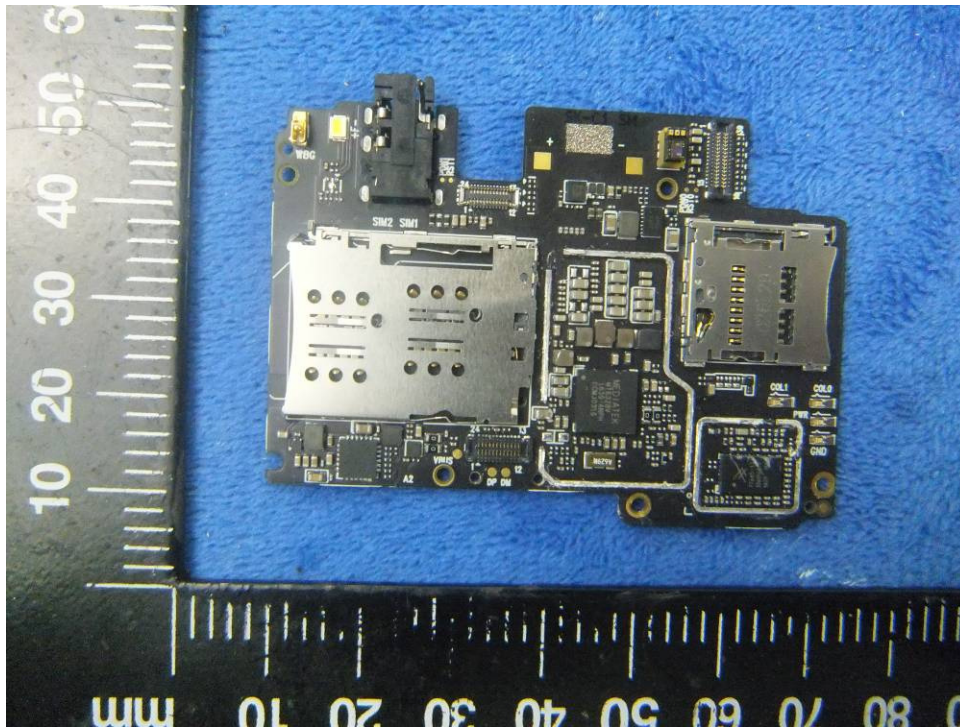



LCD – Front View



LCD – Rear View



GSM/PCS/UMTS-FDD Antenna View



WIFI/BT/BLE/GPS - Antenna View

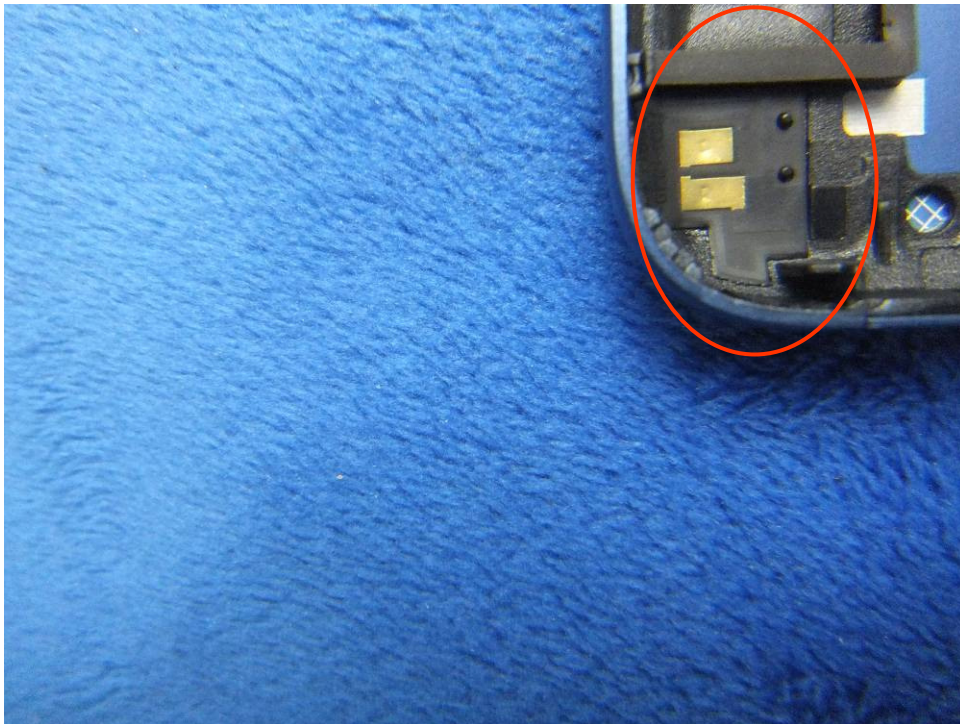



LTE - Antenna View



**Annex B.iii. Photograph: Test Setup Photo**



Conducted Emissions Test Setup Front View



Conducted Emissions Test Setup Side View

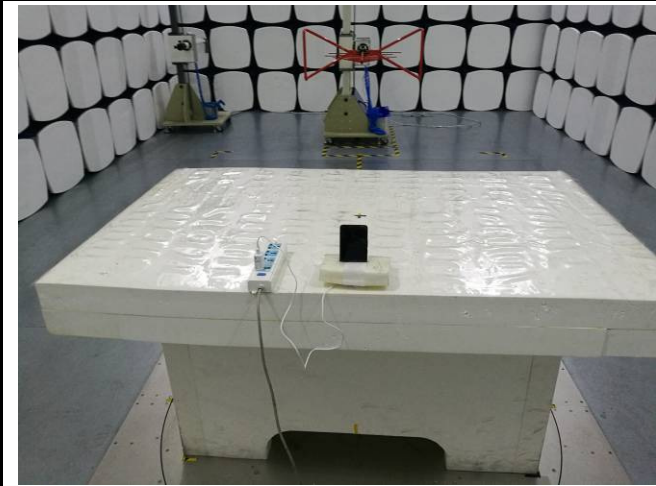

Radiated Spurious Emissions Test Setup Below 1GHz

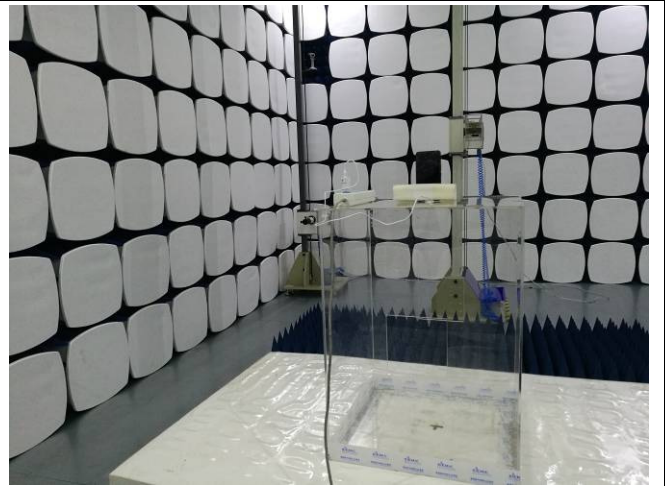

Radiated Spurious Emissions Test Setup Above  
1GHz

## Annex C. TEST SETUP AND SUPPORTING EQUIPMENT

### Annex C.ii. TEST SET UP BLOCK

#### Block Configuration Diagram for AC Line Conducted Emissions

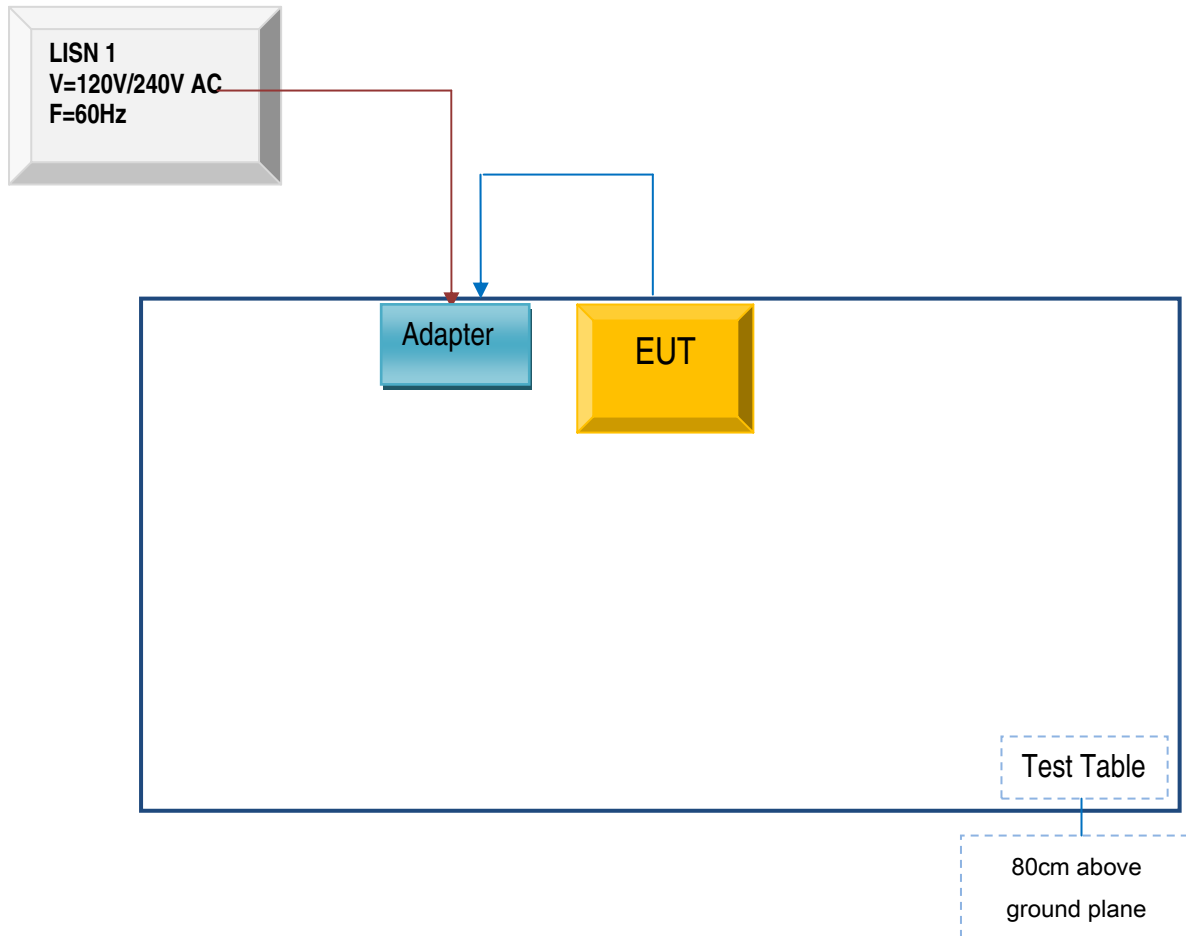

Block Configuration Diagram for Radiated Emissions ( Below 1GHz ) .

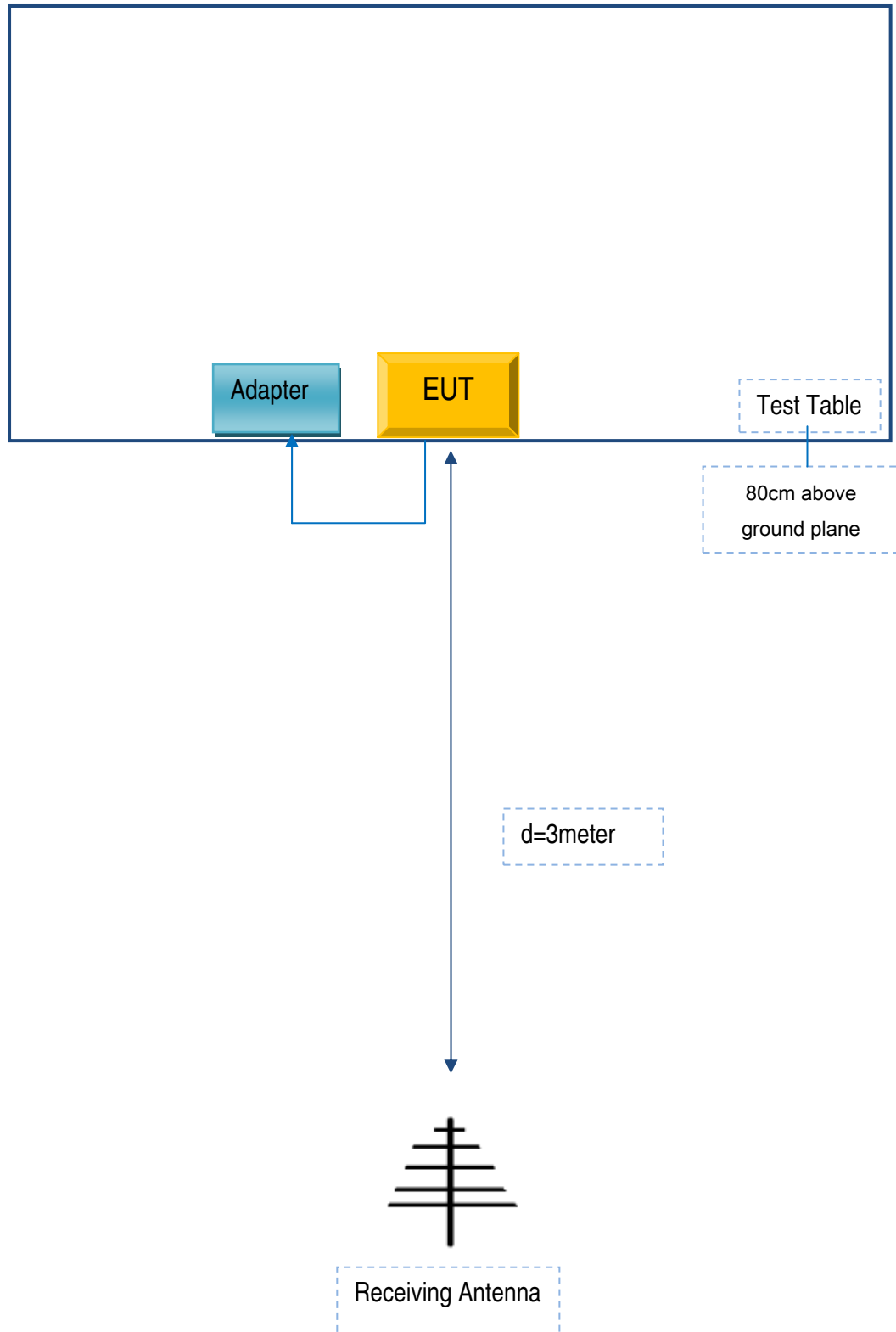

Block Configuration Diagram for Radiated Emissions ( Above 1GHz ) .

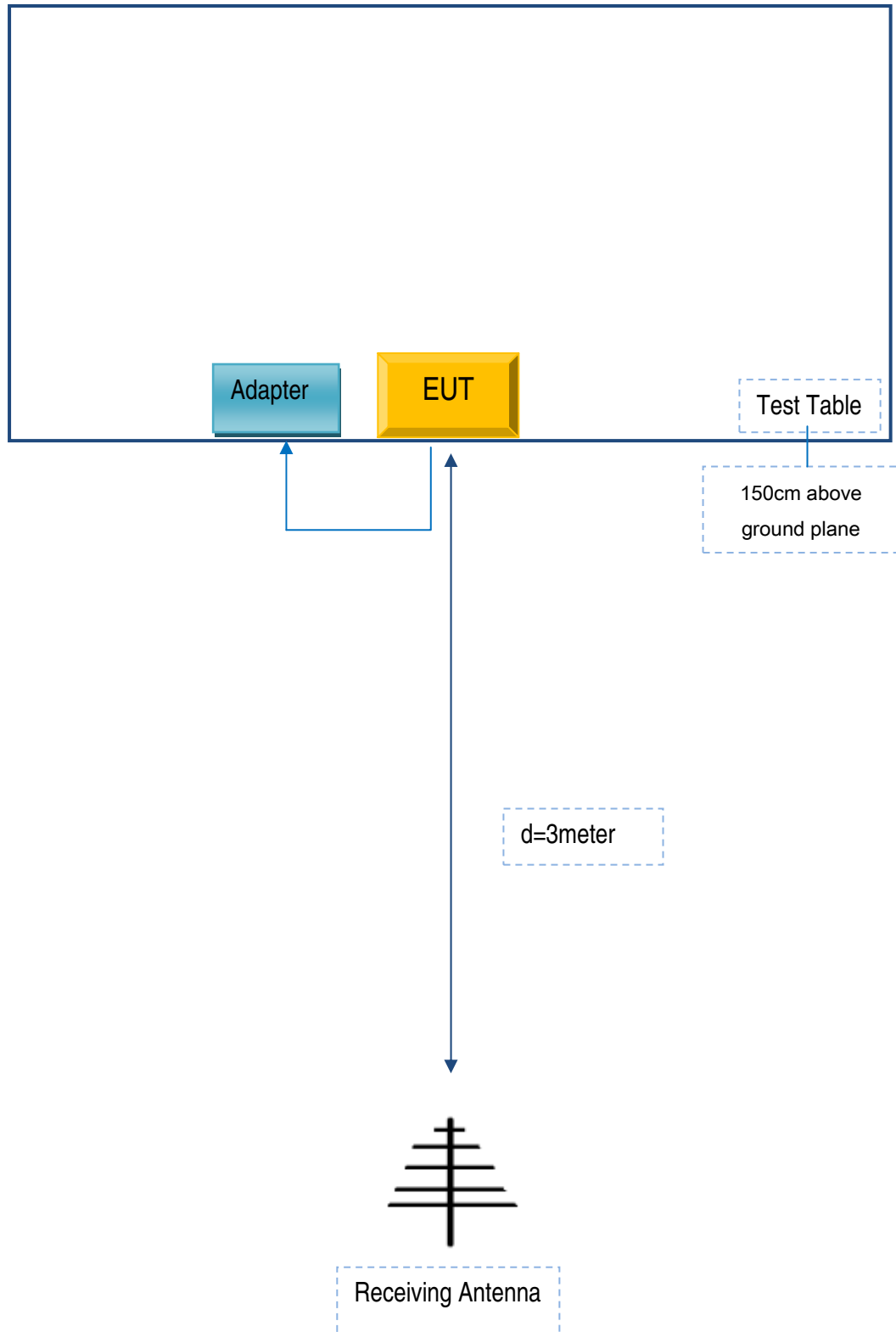

## Annex C. ii. SUPPORTING EQUIPMENT DESCRIPTION

The following is a description of supporting equipment and details of cables used with the EUT.

### Supporting Equipment:

Manufacturer	Equipment Description	Model	Serial No
TECNO MOBILE LIMITED	Adapter	A8-50100	F1012

### Supporting Cable:

Cable type	Shield Type	Ferrite Core	Length	Serial No
USB Cable	Un-shielding	No	0.8m	F1012



Test Report	17070226-FCC-R3
Page	65 of 66

**Annex D. User Manual / Block Diagram / Schematics / Partlist**

Please see the attachment

Test Report	17070226-FCC-R3
Page	66 of 66

## Annex E. DECLARATION OF SIMILARITY

N/A