



FCC SAR Compliance Test Report

For

TECNO MOBILE LIMITED

FLAT N 16/F BLOCK B UNIVERSAL INDUSTRIAL CENTRE 19-25 SHAN MEI STREET

FOTAN NT HONGKONG

Model: T16MA

Test Engineer: Zeng Longhao *Zeng Longhao*

Report Number: WSCT-A2LA-R&E240300013A-SAR

Report Date: 03 September 2024

FCC ID: 2ADYY-T16MA

Check By: Wei Liangmei *Wei Liangmei*

Approved By: Liu Fuxin *Liu Fuxin*

Prepared By: World Standardization Certification & Testing Group (Shenzhen) Co., Ltd.
Building A-B, Baoshi Science & Technology Park,
Baoshi Road, Bao'an District, Shenzhen, Guangdong,
China
Tel: +86-755-26996192
Fax: +86-755-86376605





Table of contents

1	General information	4
1.1	Notes	4
1.2	Application details	4
1.3	Statement of Compliance	5
1.4	EUT Information	6
2	Testing laboratory	7
3	ACCREDITATIONS	7
4	Test Environment	7
5	Applicant and Manufacturer	7
6	Test standard/s:	8
6.1	RF exposure limits	9
6.2	SAR Definition	9
7	SAR Measurement System	10
7.1	The Measurement System	10
7.2	Robot	11
7.3	Probe	11
7.4	Measurement procedure	13
7.5	Description of interpolation/extrapolation scheme	13
7.6	Phantom	14
7.7	Device Holder	15
7.8	Video Positioning System	16
7.9	Tissue simulating liquids: dielectric properties	17
7.10	Tissue simulating liquids: parameters	18
8	System Check	19
8.1	System check procedure	19
8.2	System check results	20





9	SAR Test Test Configuration	21
9.1	Wi-Fi Test Configuration.....	21
9.2	WiFi 5G SAR Test Procedures.....	22
10	Detailed Test Results.....	24
10.1	Conducted Power measurements.....	24
10.1.1	Conducted Power of Wi-Fi 2.4G.....	24
10.1.2	Conducted Power of Wi-Fi 5G.....	27
10.1.3	Conducted Power of BT.....	31
10.1.4	Tune-up powertolerance.....	32
10.2	SAR test results.....	33
10.2.1	Results overview of Wi-Fi 2.4G.....	34
10.2.2	Results overview of Wi-Fi 5G.....	35
10.2.3	Results overview of BT.....	36
11	Multiple Transmitter Information.....	37
11.1.1	Stand-alone SAR test exclusion.....	38
11.1.2	Simultaneous Transmission SAR Summation Scenario.....	39
11.2	Measurement uncertainty evaluation for SAR test.....	40
11.3	Measurement uncertainty evaluation for system check.....	42
12	Test equipment and ancillaries used for tests.....	44
Annex A:	System performance verification.....	45
Annex B:	Measurement results.....	45
Annex C:	Calibrationreports.....	45
Annex D:	Photographs.....	45





Modified History

REV.	Modification Description	Issued Date	Remark
REV.1.0	Initial Test Report Relesse	03 September 2024	Liu Fuxin

1 General information

1.1 Notes

The test results of this test report relate exclusively to the test item specified in this test report. QTC Certification & Testing Co., Ltd. does not assume responsibility for any conclusions and generalisations drawn from the test results with regard to other specimens or samples of the type of the equipment represented by the test item. The test report is not to be reproduced or published in full without the prior written permission.

1.2 Application details

Date of receipt of test item: 2024-04-03
 Start of test: 2024-04-08
 End of test: 2024-05-10





1.3 Statement of Compliance

The maximum results of Specific Absorption Rate (SAR) found during testing for T16MA is as below:

Band	Position	MAX Reported SAR _{1g} (W/kg)	Limit (W/kg)
2.4G WIFI	Body-Worn 0mm	0.240	1.6
5.2G WIFI	Body-Worn 0mm	0.172	
5.4G WIFI	Body-Worn 0mm	0.160	
5.6G WIFI	Body-Worn 0mm	0.149	
5.8G WIFI	Body-Worn 0mm	0.180	
BT	Body-Worn 0mm	0.102	
Max.Simultaneous Transmission SAR(W/kg)			
Items	Body SAR (Gap 0mm)		1.6
Sum SAR	0.342		

The device is in compliance with Specific Absorption Rate(SAR) for general population/uncontrolled exposure limits of 1.6W/Kg as averaged over any 1g tissue according to the FCC rule§2.1093,the ANSI/IEEEC95.1:2005,the NCRP Report Number 86 forun controlled environment,according to the Industry Canada Radio Standards Specification RSS-102 for General Population/ Uncontrolled exposure, and had been tested in accord ance with the measurement methods and proceduresspecified in IEEE Std1528-2013.





1.4 EUT Information

Device Information:			
Product Type:	Laptop Computer		
Model:	T16MA		
Brand Name:	TECNO		
Device Type:	Portable device		
Exposure Category:	uncontrolled environment / general population		
Production Unit or Identical Prototype:	Production Unit		
Antenna Type :	Integral Antenna		
Antenna Gain:	BT: 2.40dBi 2.4GWIFI: MAIN ANT: 2.40dBi /AUX ANT: 2.70 dBi 5GWIFI: MAIN ANT: 2.02dBi /AUX ANT: 2.91 dBi		
Device Operating Configurations:			
Supporting Mode(s) :	Wi-Fi , BT		
Modulation:	DSSS, OFDM/OFDMA GFSK/π/4-DQPSK/ 8-DPSK, GFSK		
Device Class :	Class B, No DTM Mode		
Operating Frequency Range(s):	Band	TX(MHz)	RX(MHz)
	Wi-Fi	2412~2462	
	Wi-Fi (5G)	Band 1: 5180-5240 MHz Band 2: 5260-5320 MHz Band 3: 5500-5700 MHz Band 4: 5745-5825 MHz	
	BT	2402~2480	2402~2480
Power Source:	Rechargeable Li-ion Battery: 528282-3S1P Rated Voltage: 11.61V Rated Capacity: 6460mAh/75Wh Typical Capacity: 6550mAh/76.04Wh Limited Charge Voltage: 13.35V		

Note:

- The test results of this test report relate exclusively to the test item specified in this test report. World Standardization Certification & Testing Group (Shenzhen) Co.,Ltd does not assume responsibility for any conclusions and generalisations drawn from the test results with regard to other specimens or samples of the type of the equipment represented by the test item. The test report is not to be reproduced or published in full without the prior written permission.
- Per KDB 616217 D04 SAR for laptop and tablets, The standalone and simultaneous transmission SAR tests required for tablets are more conservative than the hotspot mode use configurations;therefore, additional testing for hotspot SAR is not required.



2 Testing laboratory

Test Site	World Standardization Certification & Testing Group (Shenzhen) Co., Ltd.
Test Location	Building A-B, Baoshi Science & Technology Park, Baoshi Road, Bao'an District, Shenzhen, Guangdong, China
Telephone	+86-755-26996192
Fax	+86-755-86376605

3 ACCREDITATIONS

Our laboratories are accredited and approved by the following approval agencies according to ISO/IEC 17025.

China **CNAS** (Registration Number: L3732)

USA **A2LA** (Certificate Number: 5768.01)

Copies of granted accreditation certificates are available for downloading from our web site, <http://www.wsct-cert.com>

4 Test Environment

	Required	Actual
Ambient temperature:	18 – 25 °C	22 ± 2 °C
Tissue Simulating liquid:	22 ± 2 °C	22 ± 2 °C
Relative humidity content:	30 – 70 %	30 – 70 %

5 Applicant and Manufacturer

Applicant/Client Name:	TECNO MOBILE LIMITED
Applicant Address:	FLAT N 16/F BLOCK B UNIVERSAL INDUSTRIAL CENTRE 19-25 SHAN MEI STREET FOTAN NT HONGKONG
Manufacturer Name:	TECNO MOBILE LIMITED
Manufacturer Address:	FLAT N 16/F BLOCK B UNIVERSAL INDUSTRIAL CENTRE 19-25 SHAN MEI STREET FOTAN NT HONGKONG





6 Test standard/s:

IEC/IEEE 62209-1528	Recommended Practice for Determining the Peak Spatial-Average Specific Absorption Rate(SAR) in the Human Head from Wireless Communications Devices:Measurement Techniques
RSS-102	Radio Frequency Exposure Compliance of Radio communication Apparatus (All Frequency Bands(Issue 5 March 2015)
KDB447498 D01	General RF Exposure Guidance v06
KDB616217 D04	SAR for laptop and tabletsv01r03
KDB248227D01	SARmeas for 802.11a/b/g v02r02
KDB865664D01	SAR Measurement 100 MHz to 6 GHz v01r04
KDB865664D02	RF Exposure Reporting v01r02





6.1 RF exposure limits

Human Exposure	Uncontrolled Environment General Population	Controlled Environment Occupational
Spatial Peak SAR* (Brain/Body/Arms/Legs)	1.60mW/g	8.00mW/g
Spatial Average SAR** (Whole Body)	0.08mW/g	0.40mW/g
Spatial Peak SAR*** (Heads/Feet/Ankle/Wrist)	4.00mW/g	20.00mW/g

The limit applied in this test report is shown in bold letters

Notes:

* The Spatial Peak value of the SAR averaged over any 1 gram of tissue (defined as a tissue volume in the shape of a cube) and over the appropriate averaging time.

** The Spatial Average value of the SAR averaged over the whole body.

*** The Spatial Peak value of the SAR averaged over any 10 grams of tissue (defined as a tissue volume in the shape of a cube) and over the appropriate averaging time.

Uncontrolled Environments are defined as locations where there is the exposure of individuals who have no knowledge or control of their exposure.

Controlled Environments are defined as locations where there is exposure that may be incurred by persons who are aware of the potential for exposure, (i.e. as a result of employment or occupation).

6.2 SAR Definition

Specific Absorption Rate is defined as the time derivative (rate) of the incremental energy (dW) absorbed by (dissipated in) an incremental mass (dm) contained in a volume element (dV) of a given density (ρ).

$$SAR = \frac{d}{dt} \left(\frac{dW}{dm} \right) = \frac{d}{dt} \left(\frac{dW}{\rho dV} \right)$$

SAR is expressed in units of watts per kilogram (W/kg). SAR can be related to the electric field at a point by

$$SAR = \frac{\sigma |E|^2}{\rho}$$

where:

σ = conductivity of the tissue (S/m)

ρ = mass density of the tissue (kg/m³)

E = rms electric field strength (V/m)



7 SAR Measurement System

7.1 The Measurement System

ComosarisasystemthatisabletodeterminetheSARdistributioninsideaphantomofhumanbeing accordingtodifferentstandards.The Comosarsystem consistsofthefollowing items:

- Maincomputerto control allthesystem
- 6 axisrobot
- Dataacquisitionssystem
- Miniature E-fieldprobe
- Device holder
- Head simulatingtissue

The followingfigure shows thesystem.



TheEUT undertestoperatingatthemaximumpowerlevelisplacedinthephoneholder,underthe phantom,whichisfilledwithheadsimulatingliquid. TheE-Fieldprobemeasurestheelectricfield insidethephantom. TheOpenSARsoftwarecomputestheresultstogiveaSARvalueina1gor10g mass.



7.2 Robot

The COMOSAR system uses the high precision robots KR 6 R900 sixx type out of the newer series from Satimo SA (France).Forthe 6-axis controller COMOSAR system, the KUKA robot controller version from Satimo is used.The KR 6 R900 sixx robot series have many features that are important for our application:

- High precision (repeatability 0.02 mm)
- High reliability (industrial design)
- Jerk-free straight movements
- Low ELF interference (the closed metallic construction shields against motor control fields)
- 6-axis controller

7.3 Probe

For themeasurements the Specific Dosimetric E-Field Probe SSE 5 with following specifications is used



Figure 1 – MVG COMOSAR Dosimetric E field Dipole

- Dynamic range: 0.01-100W/kg

Probe Length	330 mm
Length of Individual Dipoles	4.5 mm
Maximum external diameter	8 mm
Probe Tip External Diameter	5 mm
Distance between dipoles/ probe extremity	2.7 mm

- Calibration range: 300MHz to 3GHz for head & body simulating liquid.



Anglebetween probeaxis(evaluation axis) andsurface normal line:less than30°



Figure 2 – MVG COMOSAR Dosimetric E field Dipole

Dynamicrange:0.01-100W/kg

Probe Length	330 mm
Lengthof Individual Dipoles	2 mm
Maximum externaldiameter	8 mm
ProbeTip ExternalDiameter	2.5 mm
Distance betweendipoles/ probeextremity	1 mm

-Calibration range: 5GHzto 6GHzfor head&body simulating liquid.

Anglebetween probeaxis(evaluation axis) andsurface normal line:less than30°





7.4 Measurement procedure

The following steps are used for each test position

- Establish a call with the maximum output power with a base station simulator. The connection between the mobile and the base station simulator is established via air interface.
- Measurement of the local E-field value at a fixed location. This value serves as a reference value for calculating a possible power drift.
- Measurement of the SAR distribution with a grid of 8 to 16 mm * 8 to 16 mm and a constant distance to the inner surface of the phantom. Since the sensors can not directly measure at the inner phantom surface, the values between the sensors and the inner phantom surface are extrapolated. With these values the area of the maximum SAR is calculated by an interpolation scheme.
- Around this point, a cube of 30 * 30 * 30 mm or 32 * 32 * 32 mm is assessed by measuring 5 or 8 * 5 or 8 * 4 or 5 mm. With these data, the peak spatial-average SAR value can be calculated.

7.5 Description of interpolation/extrapolation scheme

- The local SAR inside the phantom is measured using small dipole sensing elements inside a probe body. The probe tip must not be in contact with the phantom surface in order to minimize measurements errors, but the highest local SAR will occur at the surface of the phantom.
- An extrapolation is used to determine this highest local SAR values. The extrapolation is based on a fourth-order least-square polynomial fit of measured data. The local SAR value is then extrapolated from the liquid surface with a 1 mm step.
- The measurements have to be performed over a limited time (due to the duration of the battery) so the step of measurement is high. It could vary between 5 and 8 mm. To obtain an accurate assessment of the maximum SAR average over 10 grams and 1 gram requires a very fine resolution in the three dimensional scanned data array.



7.6 Phantom

For the measurements the Specific Anthropomorphic Mannequin (SAM) defined by the IEEE SCC-34/SC2 group is used. The phantom is a polyurethane shell integrated in a woodentable. The thickness of the phantom amounts to 2mm +/- 0.2mm. It enables the dosimetric evaluation of left and right phone usage and includes an additional flat phantom part for the simplified performance check. The phantom set-up includes a cover, which prevents the evaporation of the liquid.



SystemMaterial	Permittivity	LossTangent
Delrin	3.7	0.005



7.7 Device Holder

The positioning system allows obtaining cheek and tilting position with very good accuracy. In compliance with CENELEC, the tilt angle uncertainty is lower than 1°.

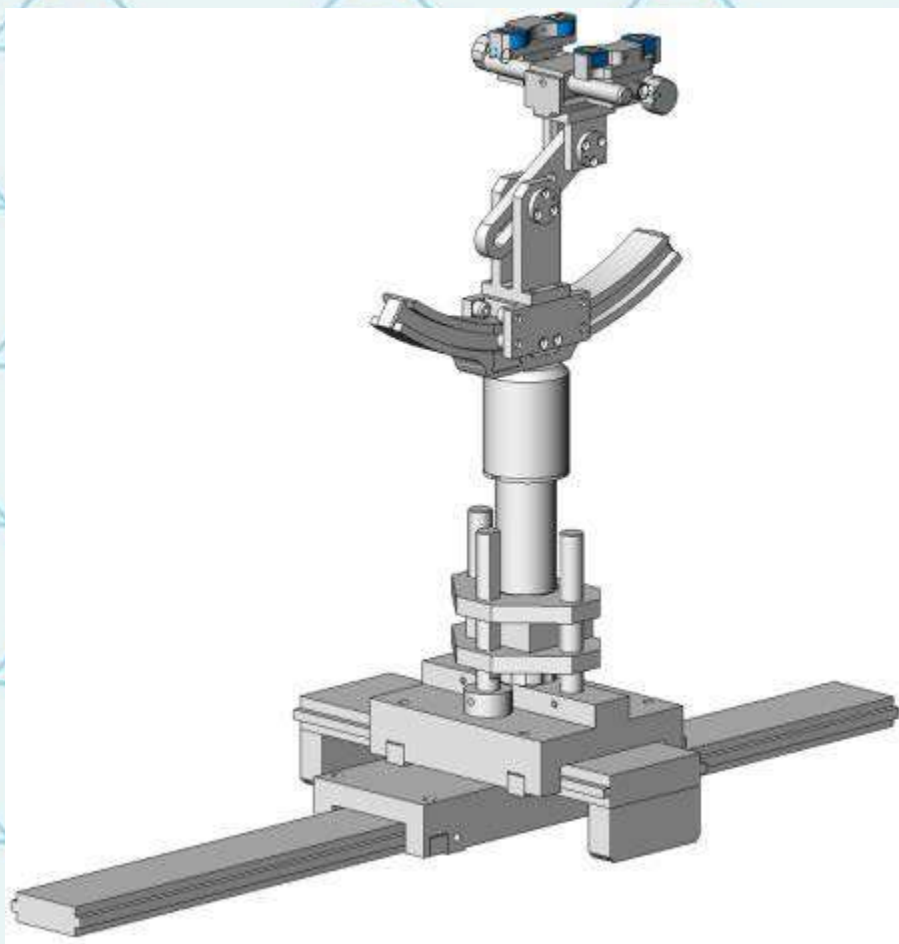

Deviceholder

SystemMaterial	Permittivity	LossTangent
Delrin	3.7	0.005



7.8 Video Positioning System

- The video positioning system is used in OpenSAR to check the probe. Which is composed of a camera, LED, mirror and mechanical parts. The camera is piloted by the main computer with firewire link.
- During the process, the actual position of the probe tip with respect to the robot arm is measured, as well as the probe length and the horizontal probe offset. The software then corrects all movements, such that the robot coordinates are valid for the probe tip.
- The repeatability of this process is better than 0.1 mm. If a position has been taught with an aligned probe, the same position will be reached with another aligned probe within 0.1 mm, even if the other probe has different dimensions. During probe rotations, the probe tip will keep its actual position.





7.9 Tissue simulating liquids: dielectric properties

The following materials are used for producing the tissue-equivalent materials.

(Liquids used for tests are marked with):

Ingredients(% of weight)	Frequency (MHz)				
frequency band	<input type="checkbox"/> 450	<input type="checkbox"/> 835	<input type="checkbox"/> 1800	<input type="checkbox"/> 1900	<input type="checkbox"/> 2450
Tissue Type	Head	Head	Head	Head	Head
Water	38.56	41.45	52.64	55.242	62.7
Salt (NaCl)	3.95	1.45	0.36	0.306	0.5
Sugar	56.32	56.0	0.0	0.0	0.0
HEC	0.98	1.0	0.0	0.0	0.0
Bactericide	0.19	0.1	0.0	0.0	0.0
Triton X-100	0.0	0.0	0.0	0.0	36.8
DGBE	0.0	0.0	47.0	44.542	0.0
Ingredients(% of weight)	Frequency (MHz)				
frequency band	<input type="checkbox"/> 450	<input checked="" type="checkbox"/> 835	<input type="checkbox"/> 1800	<input type="checkbox"/> 1900	<input checked="" type="checkbox"/> 2450
Tissue Type	Body	Body	Body	Body	Body
Water	51.16	52.4	69.91	69.91	73.2
Salt (NaCl)	1.49	1.40	0.13	0.13	0.04
Sugar	46.78	45.0	0.0	0.0	0.0
HEC	0.52	1.0	0.0	0.0	0.0
Bactericide	0.05	0.1	0.0	0.0	0.0
Triton X-100	0.0	0.0	0.0	0.0	0.0
DGBE	0.0	0.0	29.96	29.96	26.7

Salt: 99+% Pure Sodium Chloride

Sugar: 98+% Pure Sucrose

Water: De-ionized, 16MΩ+ resistivity

HEC: Hydroxyethyl Cellulose

DGBE: 99+% Di(ethylene glycol) butyl ether, [2-(2-butoxyethoxy)ethanol]

Triton X-100(ultra pure): Polyethylene glycol mono [4-(1,1,3,3-tetramethylbutyl)phenyl]ether

Simulating Head Liquid for 5G(HBBL3500-5800MHz), Manufactured by SPEAG:

Ingredients	(% by weight)
Water	50-65%
Mineral oil	10-30%
Emulsifiers	8-25%
Sodium salt	0-1.5%

Simulating Body Liquid for 5G(MBBL3500-5800MHz), Manufactured by SPEAG:

Ingredients	(% by weight)
Water	60-80%
Esters, Emulsifiers, Inhibitors	20-40%
Sodium salt	0-1.5%



7.10 Tissue simulating liquids: parameters

Tissue Type	Measured Frequency (MHz)	Target Tissue				Measured Tissue		Liquid Temp.	Test Date
		Target Permittivity ϵ_r	Range of $\pm 5\%$	Target Conductivity σ (S/m)	Range of $\pm 5\%$	ϵ_r	σ (S/m)		
2450MHz Body	2410	52.80	50.16~55.44	1.91	1.81~2.00	52.50	1.94	21.6°C	2024-04-20
	2435	52.70	50.07~55.34	1.94	1.84~2.04	52.52	1.95		
	2450	52.70	50.07~55.34	1.95	1.85~2.05	52.73	1.96		
	2460	52.70	50.07~55.34	1.96	1.86~2.06	52.76	1.99		
5G Body	5200	49.00	46.55~51.45	5.30	5.03~5.56	49.86	5.19	21.6°C	2024-04-20
	5300	48.90	46.05~51.35	5.42	5.15~5.69	48.32	5.27		
	5800	48.20	45.79~50.61	6.00	5.70~6.30	47.74	6.09		

ϵ_r = Relative permittivity, σ = Conductivity





8 System Check

8.1 System check procedure

The System check is performed by using a System check dipole which is positioned parallel to the planar part of the SAM phantom at the reference point. The distance of the dipole to the SAM phantom is determined by a spacer. The dipole is connected to the signal source consisting of signal generator and amplifier via a directional coupler, N-connector cable and adaption to SMA. It is fed with a power of 100 mW. To adjust this power a power meter is used. The power sensor is connected to the cable before the System check to measure the power at this point and do adjustments at the signal generator. At the outputs of the directional coupler both return loss as well as forward power are controlled during the validation to make sure that emitted power at the dipole is kept constant. This can also be checked by the power drift measurement after the test (result on plot).

System check results have to be equal or near the values determined during dipole calibration (target SAR in table above) with the relevant liquids and test system.

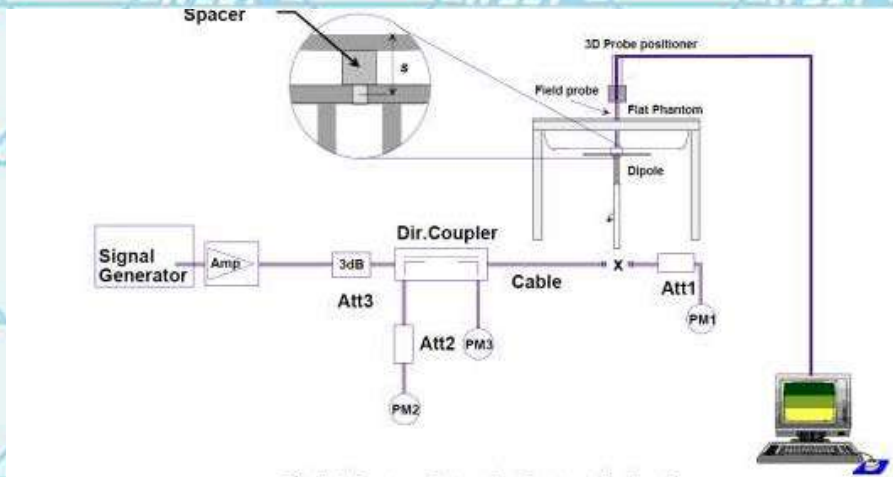



8.2 System check results

The system Check is performed for verifying the accuracy of the complete measurement system and performance of the software. The following table shows System check results for all frequency bands and tissue liquids used during the tests (plot(s) see annex A).

System Check	Target SAR (1W) (+/-10%)				Measured SAR (Normalized to 1W)		Liquid Temp.	Test Date
	1-g (W/g)	Range of $\pm 10\%$ 1-g (W/g)	10-g (W/g)	Range of $\pm 10\%$ 10-g (W/g)	1-g (W/g)	10-g (W/g)		
D2450V2 Head	51.39	46.25~56.53	23.63	21.27~25.99	53.630	22.650	21.6°C	2024-04-20
D5200V2 Head	163.36	147.03~179.69	57.09	51.39~62.79	167.180	59.640	21.6°C	2024-04-20
D5300V2 Head	166.22	149.60~182.84	57.22	51.50~62.94	165.370	58.820	21.6°C	2024-04-20
D5800V2 Head	177.10	159.39~194.81	59.95	53.96~65.94	179.660	60.800	21.6°C	2024-04-20

Note: All SAR values are normalized to 1W forward power.

Note: 5G band system check USES standard waveguide, so the test results are standard en62209-2 table B2





9 SAR Test Test Configuration

9.1 Wi-Fi Test Configuration

For the 802.11b/g SAR tests, a communication link is set up with the test mode software for Wi-Fi mode test. The Absolute Radio Frequency Channel Number(ARFCN) is allocated to 1 ,6 and 11 respectively in the case of 2450 MHz.During the test,at the each test frequency channel, the EUT is operated at the RF continuous emission mode. Each channel should be tested at the lowest data rate. 802.11b/g operating modes are tested independently according to the service requirements in each frquency band. 802.11b/g modes are tested on channel 1, 6, 11; however,if output power reduction is necessary for channels 1 and/or 11 to meet restricted band requirements the highest output channel closest to each of these channels must be tested instead.

SAR is not required for 802.11g/n channels when the maximum average output power is less than 0.25dB higher than that measured on the corresponding 802.11b channels.

Mode	Band	GHz	Channel	"Default Test Channels"	
				802.11b	802.11g
802.11b/g	2.4 GHz	2412	1#	√	△
		2437	6	√	△
		2462	11#	√	△

Notes:

√ = "default test channels"

△= possible 802.11g channels with maximum average output ¼ dB the "default test channels"

= when output power is reduced for channel 1 and /or 11 to meet restricted band requirements the highest output channels closest to each of these channels should be tested.

802.11 Test Channels per FCC Requirements



9.2 WiFi 5G SAR Test Procedures

A) U-NII-1 and U-NII-2A Bands

For devices that operate in only one of the U-NII-1 and U-NII-2A bands, the normally required SAR procedures for OFDM configurations are applied. For devices that operate in both U-NII bands using the same transmitter and antenna(s), SAR test reduction is determined according to the following:

1) When the same maximum output power is specified for both bands, begin SAR measurement in U-NII-2A band by applying the OFDM SAR requirements. If the highest reported SAR for a test configuration is ≤ 1.2 W/kg, SAR is not required for U-NII-1 band for that configuration (802.11 mode and exposure condition); otherwise, both bands are tested independently for SAR.

2) When different maximum output power is specified for the bands, begin SAR measurement in the band with higher specified maximum output power. The highest reported SAR for the tested configuration is adjusted by the ratio of lower to higher specified maximum output power for the two bands. When the adjusted SAR is ≤ 1.2 W/kg, SAR is not required for the band with lower maximum output power in that test configuration; otherwise, both bands are tested independently for SAR.

3) The two U-NII bands may be aggregated to support a 160 MHz channel on channel number 50.

Without additional testing, the maximum output power for this is limited to the lower of the maximum output power certified for the two bands. When SAR measurement is required for at least one of the bands and the highest reported SAR adjusted by the ratio of specified maximum output power of aggregated to standalone band is > 1.2 W/kg, SAR is required for the 160 MHz channel. This procedure does not apply to an aggregated band with maximum output higher than the standalone band(s); the aggregated band must be tested independently for SAR. SAR is not required when the 160 MHz channel is operating at a reduced maximum power and also qualifies for SAR test exclusion.

B) U-NII-2C and U-NII-3 Bands

The frequency range covered by these bands is 380 MHz (5.47 – 5.85 GHz), which requires a minimum of at least two SAR probe calibration frequency points to support SAR measurements. When Terminal Doppler Weather Radar (TDWR) restriction applies, all channels that operate at 5.60 – 5.65 GHz must be included to apply the SAR test reduction and measurement procedures.

When the same transmitter and antenna(s) are used for U-NII-2C band and U-NII-3 band or 5.8 GHz band of §15.247, the bands may be aggregated to enable additional channels with 20, 40 or 80 MHz bandwidth to span across the band gap, as illustrated in Appendix B. The maximum output power for the additional band gap channels is limited to the lower of those certified for the bands. Unless band gap channels are permanently disabled, they must be considered for SAR testing. The frequency range covered by these bands is 380 MHz (5.47 – 5.85 GHz), which requires a minimum of at least two SAR probe calibration frequency points to support SAR measurements. To maintain SAR measurement accuracy and to facilitate test reduction, the channels in U-NII-2C band above 5.65 GHz may be grouped with the 5.8 GHz channels in U-NII-3 or §15.247 band to enable two SAR probe calibration frequency points to cover the bands, including the band gap channels. When band gap channels are supported and the bands are not aggregated for SAR testing, band gap channels must be considered independently in each band according to the normally required OFDM SAR measurement and probe calibration frequency points requirements.



C) OFDM Transmission Mode SAR Test Configuration and Channel Selection Requirements

The initial test configuration for 5 GHz OFDM transmission modes is determined by the 802.11 configuration with the highest maximum output power specified for production units, including tune-up tolerance, in each standalone and aggregated frequency band. SAR for the initial test configuration is measured using the highest maximum output power channel determined by the default power measurement procedures. When multiple configurations in a frequency band have the same specified maximum output power, the initial test configuration is determined according to the following steps applied sequentially.

- 1) The largest channel bandwidth configuration is selected among the multiple configurations with the same specified maximum output power.
- 2) If multiple configurations have the same specified maximum output power and largest channel bandwidth, the lowest order modulation among the largest channel bandwidth configurations is selected.
- 3) If multiple configurations have the same specified maximum output power, largest channel bandwidth and lowest order modulation, the lowest data rate configuration among these configurations is selected.
- 4) When multiple transmission modes (802.11a/g/n/ac) have the same specified maximum output power, largest channel bandwidth, lowest order modulation and lowest data rate, the lowest order 802.11 mode is selected; i.e., 802.11a is chosen over 802.11n then 802.11ac or 802.11g is chosen over 802.11n. After an initial test configuration is determined, if multiple test channels have the same measured maximum output power, the channel chosen for SAR measurement is determined according to the following. These channel selection procedures apply to both the initial test configuration and subsequent test configuration(s), with respect to the default power measurement procedures or additional power measurements required for further SAR test reduction. The same procedures also apply to subsequent highest output power channel(s) selection.

- 1) The channel closest to mid-band frequency is selected for SAR measurement.
- 2) For channels with equal separation from mid-band frequency; for example, high and low channels or two mid-band channels, the higher frequency (number) channel is selected for SAR measurement.

D) SAR Test Requirements for OFDM configurations

When SAR measurement is required for 802.11 a/n/ac OFDM configurations, each standalone and frequency aggregated band is considered separately for SAR test reduction. When the same transmitter and antenna(s) are used for U-NII-1 and U-NII-2A bands, additional SAR test reduction applies. When band gap channels between U-NII-2C band and 5.8 GHz U-NII-3 or §15.247 band are supported, the highest maximum output power transmission mode configuration and maximum output power channel over the bands must be used to determine SAR test reduction, according to the initial test configuration and subsequent test configuration requirements. In applying the initial test configuration and subsequent test configuration procedures, the 802.11 transmission configuration with the highest specified maximum output power and the channel within a test configuration with the highest measured maximum output power should be clearly distinguished to apply the procedures.



10 Detailed Test Results

10.1 Conducted Power measurements

The measuring conducted average power (Unit: dBm) is shown as below.

10.1.1 Conducted Power of Wi-Fi 2.4G

MAIN ANT1

Mode	802.11b		
Channel/Frequency(MHz)	1(2412)	6(2437)	11(2462)
Average Power(dBm)	16.95	16.78	16.79
Mode	802.11g		
Channel/Frequency(MHz)	1(2412)	6(2437)	11(2462)
Average Power(dBm)	20.07	20.17	19.87
Mode	802.11n(HT20)		
Channel/Frequency(MHz)	1(2412)	6(2437)	11(2462)
Average Power(dBm)	20.03	20.06	19.75
Mode	802.11n(HT40)		
Channel/Frequency(MHz)	3(2422)	6(2437)	9(2452)
Average Power(dBm)	17.18	20.43	19.01
Mode	802.11ax 20		
Channel/Frequency(MHz)	1(2412)	6(2437)	11(2462)
Average Power(dBm)	20.21	20.28	20.01
Mode	802.11ax40		
Channel/Frequency(MHz)	3(2422)	6(2437)	9(2452)
Average Power(dBm)	17.18	20.58	19.24

AUX ANT2

Mode	802.11b		
Channel/Frequency(MHz)	1(2412)	6(2437)	11(2462)
Average Power(dBm)	16.85	16.76	16.65
Mode	802.11g		
Channel/Frequency(MHz)	1(2412)	6(2437)	11(2462)
Average Power(dBm)	20.04	20.15	19.29
Mode	802.11n(HT20)		
Channel/Frequency(MHz)	1(2412)	6(2437)	11(2462)
Average Power(dBm)	19.82	19.93	19.22
Mode	802.11n(HT40)		
Channel/Frequency(MHz)	1(2412)	6(2437)	11(2462)
Average Power(dBm)	17.15	20.34	19.93
Mode	802.11ax 20		
Channel/Frequency(MHz)	1(2412)	6(2437)	11(2462)
Average Power(dBm)	20.15	20.24	19.57
Mode	802.11ax 40		
Channel/Frequency(MHz)	3(2422)	6(2437)	9(2452)
Average Power(dBm)	17.32	20.43	20.11

MIMO Mode

Mode	802.11n(HT20)		
Channel/Frequency(MHz)	1(2412)	6(2437)	11(2462)
Average Power(dBm)	22.94	23.01	22.50
Mode	802.11n(HT40)		
Channel/Frequency(MHz)	1(2412)	6(2437)	11(2462)
Average Power(dBm)	20.18	23.40	22.50
Mode	802.11ax 20		
Channel/Frequency(MHz)	1(2412)	6(2437)	11(2462)
Average Power(dBm)	23.19	23.27	22.81
Mode	802.11ax 40		
Channel/Frequency(MHz)	3(2422)	6(2437)	9(2452)
Average Power(dBm)	20.26	23.52	22.71



<KDB 248227 D01, SAR Guidance for Wi-Fi Transmitters>

(1) For handsets operating next to ear, hotspot mode or mini-tablet configurations, the initial test position procedures were applied. The test position with the highest extrapolated peak SAR will be used as the initial test position. When the reported SAR of initial test position is ≤ 0.4 W/kg, SAR testing for remaining test positions is not required. Otherwise, SAR is evaluated at the subsequent highest peak SAR positions until the reported SAR result is ≤ 0.8 W/kg or all test positions are measured.

(2) For Wi-Fi 2.4 GHz, the highest measured maximum output power channel for DSSS was selected for SAR measurement. When the reported SAR is ≤ 0.8 W/kg, no further SAR testing is required. Otherwise, SAR is evaluated at the next highest measured output power channel. When any reported SAR is > 1.2 W/kg, SAR is required for the third channel. For OFDM modes (802.11g/n), SAR is not required when the highest reported SAR for DSSS is adjusted by the ratio of OFDM to DSSS specified maximum output power and it is ≤ 1.2 W/kg.



10.1.2 Conducted Power of Wi-Fi 5G

Ant 1						
Band	Mode	Channel	Frequency(MHz)	Tune-up	Average Power (dBm)	SAR Test (Yes/No)
U-NII-1 (5150-5250)	802.11a	36	5180	10.50±1.0	10.26	No
		48	5240	10.50 ±1.0	10.08	No
	802.11n-HT20	36	5180	10.50±1.0	10.21	No
		48	5240	10.50±1.0	10.08	No
	802.11n-HT40	38	5190	11.50±1.0	11.35	No
		46	5230	12.00±1.0	11.75	Yes
	802.11ac-VHT20	36	5180	10.50±1.0	10.12	No
		48	5240	10.00±1.0	9.98	No
	802.11ac-VHT40	38	5190	11.50±1.0	11.19	No
		46	5230	12.00±1.0	11.59	No
	802.11ac-VHT80	42	5210	11.50±1.0	11.45	No
	802.11ax- HT160	50	5250	6.00±1.0	5.93	No
	802.11ax-HT20	36	5180	10.00±1.0	9.95	No
		48	5240	10.00±1.0	9.88	No
802.11ax-HT40	38	5190	11.00±1.0	10.95	No	
	46	5230	11.50±1.0	11.46	No	
802.11ax-HT80	42	5210	11.50±1.0	11.20	No	
Ant 2						
Band	Mode	Channel	Frequency(MHz)	Tune-up	Average Power (dBm)	SAR Test (Yes/No)
U-NII-1 (5150-5250)	802.11a	36	5180	9.50±1.0	9.05	No
		48	5240	9.00±1.0	8.94	No
	802.11n-HT20	36	5180	12.50±1.0	12.36	No
		48	5240	12.50±1.0	12.10	No
	802.11n-HT40	38	5190	13.50±1.0	13.43	No
		46	5230	14.00±1.0	13.85	Yes
	802.11ac-VHT20	36	5180	12.50±1.0	12.28	No
		48	5240	12.50±1.0	12.06	No
	802.11ac-VHT40	38	5190	13.50±1.0	13.18	No
		46	5230	14.00±1.0	13.57	No
	802.11ac-VHT80	42	5210	14.00±1.0	13.65	No
	802.11ax- HT160	50	5250	8.50±1.0	8.25	No
	802.11ax-HT20	36	5180	12.50±1.0	12.04	No
		48	5240	12.00±1.0	11.83	No
802.11ax-HT40	38	5190	13.00±1.0	12.91	No	
	46	5230	13.50±1.0	13.40	No	
802.11ax-HT80	42	5210	13.50±1.0	13.39	No	
MIMO						
Band	Mode	Channel	Frequency(MHz)	Tune-up	Average Power (dBm)	SAR Test (Yes/No)
U-NII-1 (5150-5250)	802.11n-HT20	36	5180	14.50±1.0	14.43	No
		48	5240	14.50±1.0	14.22	No
	802.11n-HT40	38	5190	16.00±1.0	15.52	No
		46	5230	16.00±1.0	15.94	Yes
	802.11ac-VHT20	36	5180	14.50±1.0	14.34	No
		48	5240	14.50±1.0	14.15	No
	802.11ac-VHT40	38	5190	16.00±1.0	15.70	No
		46	5230	15.50±1.0	15.44	No
	802.11ac-VHT80	42	5210	16.00±1.0	15.70	No
	802.11ax- HT160	50	5250	10.50±1.0	10.25	No
	802.11ax-HT20	36	5180	14.50±1.0	14.13	No
		48	5240	14.00±1.0	13.97	No
	802.11ax-HT40	38	5190	15.50±1.0	15.05	No
		46	5230	16.00±1.0	15.55	No
802.11ax-HT80	42	5210	15.50±1.0	15.44	No	





Ant 1						
Band	Mode	Channel	Frequency (MHz)	Tune-up	Average Power (dBm)	SAR Test (Yes/No)
U-NII-2a (5250-5350)	802.11a	52	5260	10.00±1.0	9.97	No
		64	5320	10.50±1.0	10.36	No
	802.11n-HT20	52	5260	10.00±1.0	9.99	No
		64	5320	10.50±1.0	10.34	No
	802.11n-HT40	54	5270	12.00±1.0	11.58	Yes
		62	5310	11.00±1.0	10.99	No
	802.11ac-VHT20	52	5260	10.00±1.0	9.92	No
		64	5320	10.50±1.0	10.30	No
	802.11ac-VHT40	54	5270	11.50±1.0	11.43	No
		62	5310	11.00±1.0	10.86	No
	802.11ac-VHT80	58	5290	10.50±1.0	10.07	No
		52	5260	10.00±1.0	9.78	No
	802.11ax-HT20	64	5320	10.50±1.0	10.11	No
		54	5270	11.50±1.0	11.26	No
802.11ax-HT40	62	5310	11.00±1.0	10.58	No	
	58	5290	10.00±1.0	9.77	No	
Ant 2						
Band	Mode	Channel	Frequency (MHz)	Tune-up	Average Power (dBm)	SAR Test (Yes/No)
U-NII-2a (5250-5350)	802.11a	52	5260	9.00±1.0	8.76	No
		64	5320	9.50±1.0	9.3	No
	802.11n-HT20	52	5260	12.00±1.0	11.89	No
		64	5320	12.50 ±1.0	12.49	No
	802.11n-HT40	54	5270	13.50±1.0	13.42	Yes
		62	5310	13.00±1.0	12.88	No
	802.11ac-VHT20	52	5260	12.00±1.0	11.81	No
		64	5320	12.50±1.0	12.4	No
	802.11ac-VHT40	54	5270	13.50±1.0	13.24	No
		62	5310	13.00±1.0	12.76	No
	802.11ac-VHT80	58	5290	12.00 ±1.0	11.93	No
		52	5260	12.00±1.0	11.62	No
	802.11ax-HT20	64	5320	12.50±1.0	12.15	No
		54	5270	13.50±1.0	13.01	No
802.11ax-HT40	62	5310	12.50±1.0	12.49	No	
	58	5290	12.00±1.0	11.62	No	
MIMO						
Band	Mode	Channel	Frequency (MHz)	Tune-up	Average Power (dBm)	SAR Test (Yes/No)
U-NII-2a (5250-5350)	802.11n-HT20	52	5260	14.50±1.0	14.05	No
		64	5320	15.00±1.0	14.56	No
	802.11n-HT40	54	5270	16.00±1.0	15.61	Yes
		62	5310	15.50±1.0	15.05	No
	802.11ac-VHT20	52	5260	14.00±1.0	13.98	No
		64	5320	14.50±1.0	14.49	No
	802.11ac-VHT40	54	5270	15.50±1.0	15.44	No
		62	5310	15.00±1.0	14.92	No
	802.11ac-VHT80	58	5290	14.50±1.0	14.11	No
		52	5260	14.00±1.0	13.81	No
	802.11ax-HT20	64	5320	14.50±1.0	14.26	No
		54	5270	15.50±1.0	15.23	No
	802.11ax-HT40	62	5310	15.00±1.0	14.65	No
		58	5290	14.00±1.0	13.80	No



Ant 1						
Band	Mode	Channel	Frequency (MHz)	Tune-up	Average Power (dBm)	SAR Test (Yes/No)
U-NII-2c (5470-5725)	802.11a	100	5500	10.50±1.0	10.27	No
		140	5700	11.00±1.0	10.52	No
	802.11n-HT20	100	5500	11.00±1.0	10.62	No
		140	5700	11.00±1.0	10.52	No
	802.11n-HT40	102	5510	11.00±1.0	10.87	No
		134	5670	12.50±1.0	12.20	No
	802.11ac-VHT20	100	5500	10.50±1.0	10.44	No
		140	5700	11.00±1.0	10.52	No
	802.11ac-VHT40	102	5510	11.00±1.0	10.59	No
		134	5670	12.50±1.0	12.05	No
	802.11ac-VHT80	106	5530	11.50±1.0	11.22	No
		122	5610	13.00±1.0	12.91	Yes
	802.11ax- HT160	114	5570	9.00±1.0	8.87	No
		802.11ax-HT20	100	5500	10.50±1.0	10.22
	802.11ax-HT40		140	5700	10.50±1.0	10.33
		802.11ax-HT40	102	5510	10.50±1.0	10.41
802.11ax-HT40	134		5670	12.00±1.0	11.73	No
	802.11ax-HT80	106	5530	11.00±1.0	10.92	No
802.11ax-HT80		122	5610	13.00±1.0	12.68	No

Ant 2						
Band	Mode	Channel	Frequency (MHz)	Tune-up	Average Power (dBm)	SAR Test (Yes/No)
U-NII-2c (5470-5725)	802.11a	100	5500	9.00±1.0	8.83	No
		140	5700	10.50±1.0	10.11	No
	802.11n-HT20	100	5500	12.00±1.0	11.93	No
		140	5700	13.00±1.0	12.72	No
	802.11n-HT40	102	5510	12.50±1.0	12.31	No
		134	5670	14.50±1.0	14.15	No
	802.11ac-VHT20	100	5500	12.00±1.0	11.85	No
		140	5700	13.00±1.0	12.61	No
	802.11ac-VHT40	102	5510	12.50±1.0	12.02	No
		134	5670	14.00±1.0	13.96	No
	802.11ac-VHT80	106	5530	13.00±1.0	12.85	No
		122	5610	15.50±1.0	15.08	Yes
	802.11ax- HT160	114	5570	11.00±1.0	10.97	No
		802.11ax-HT20	100	5500	12.00±1.0	11.69
	802.11ax-HT20		140	5700	12.50±1.0	12.40
		802.11ax-HT40	102	5510	12.00±1.0	11.97
802.11ax-HT40	134		5670	14.00±1.0	13.79	No
	802.11ax-HT80	106	5530	13.00±1.0	12.58	No
802.11ax-HT80		122	5610	15.00±1.0	14.74	No

MIMO						
Band	Mode	Channel	Frequency (MHz)	Tune-up	Average Power (dBm)	SAR Test (Yes/No)
U-NII-2c (5470-5725)	802.11n-HT20	100	5500	14.50±1.0	14.33	No
		140	5700	15.00±1.0	14.77	No
	802.11n-HT40	102	5510	15.00±1.0	14.66	No
		134	5670	16.50±1.0	16.29	No
	802.11ac-VHT20	100	5500	14.50±1.0	14.21	No
		140	5700	15.00±1.0	14.70	No
	802.11ac-VHT40	102	5510	14.50±1.0	14.37	No
		134	5670	16.50±1.0	16.12	No
	802.11ac-VHT80	106	5530	15.50 ±1.0	15.12	No
		122	5610	17.50±1.0	17.14	Yes
	802.11ax- HT160	114	5570	13.50±1.0	13.06	No
		802.11ax-HT20	100	5500	14.50±1.0	14.03
	802.11ax-HT20		140	5700	14.50±1.0	14.50
		802.11ax-HT40	102	5510	14. ±1.0 50	14.27
	802.11ax-HT40		134	5670	16.00±1.0	15.89
		802.11ax-HT80	106	5530	15.00±1.0	14.84
802.11ax-HT80	122		5610	17.00±1.0	16.84	No





Ant 1						
Band	Mode	Channel	Frequency (MHz)	Tune-up	Average Powe(dBm)	SAR Test (Yes/No)
U-NII-3 (5725-5825)	802.11a	149	5745	11.50	11.08	No
		165	5825	11.00	10.87	No
	802.11n-HT20	149	5745	11.50	11.17	No
		165	5825	11.50	11.11	No
	802.11n-HT40	151	5755	13.00	12.73	Yes
		159	5795	13.00	12.63	No
	802.11ac-VHT20	149	5745	11.50	11.06	No
		165	5825	11.50	11.03	No
	802.11ac-VHT40	151	5755	12.50	12.47	No
		159	5795	12.50	12.43	No
	802.11ac-VHT80	155	5775	12.50	12.03	No
		149	5745	11.50	11.04	No
802.11ax-HT20	165	5825	11.50	11.01	No	
	151	5755	12.50	12.33	No	
802.11ax-HT40	159	5795	12.50	12.31	No	
	155	5775	12.00	11.86	No	
Ant 2						
Band	Mode	Channel	Frequency (MHz)	Tune-up	Average Powe(dBm)	SAR Test (Yes/No)
U-NII-3 (5725-5825)	802.11a	149	5745	13.00	12.69	No
		165	5825	13.00	12.72	No
	802.11n-HT20	149	5745	13.00	12.89	No
		165	5825	13.00	12.89	No
	802.11n-HT40	151	5755	14.50	14.23	Yes
		159	5795	14.50	14.16	No
	802.11ac-VHT20	149	5745	13.00	12.80	No
		165	5825	13.00	12.77	No
	802.11ac-VHT40	151	5755	14.50	14.05	No
		159	5795	14.00	13.99	No
	802.11ac-VHT80	155	5775	14.00	13.76	No
		149	5745	13.00	12.62	No
802.11ax-HT20	165	5825	13.00	12.59	No	
	151	5755	14.00	13.84	No	
802.11ax-HT40	159	5795	14.00	13.76	No	
	155	5775	13.50	13.48	No	
MIMO						
Band	Mode	Channel	Frequency (MHz)	Tune-up	Average Powe(dBm)	SAR Test (Yes/No)
U-NII-3 (5725-5825)	802.11n-HT20	149	5745	15.50	15.12	No
		165	5825	15.50	15.10	No
	802.11n-HT40	151	5755	17.00	16.55	Yes
		159	5795	16.50	16.47	No
	802.11ac-VHT20	149	5745	15.50	15.03	No
		165	5825	15.00	15.00	No
	802.11ac-VHT40	151	5755	16.50	16.34	No
		159	5795	16.50	16.29	No
	802.11ac-VHT80	155	5775	16.00	15.99	No
		149	5745	15.00	14.91	No
	802.11ax-HT20	165	5825	15.00	14.88	No
		151	5755	16.50	16.16	No
802.11ax-HT40	159	5795	16.50	16.11	No	
	155	5775	16.00	15.76	No	

<KDB 248227 D01, SAR Guidance for Wi-Fi Transmitters>

For WLAN 5 GHz, the initial test configuration was selected according to the transmission mode with the highest maximum output power. When the reported SAR of initial test configuration is > 0.8 W/kg, SAR is required for the subsequent highest measured output power channel until the reported SAR result is ≤ 1.2 W/kg or all required channels are measured. For other transmission modes, SAR is not required when the highest reported SAR for initial test configuration is adjusted by the ratio of subsequent test configuration to initial test configuration specified maximum output power and it is ≤ 1.2 W/kg.





10.1.3 Conducted Power of BT

The maximum output power of BT is:

Mode	GFSK mode		
Channel/Frequency(MHz)	0(2402)	39(2441)	78(2480)
Peak Power(dBm)	10.30	9.28	8.37
Mode	Pi/4DQPSK mode		
Channel/Frequency(MHz)	0(2402)	39(2441)	78(2480)
Peak Power(dBm)	8.78	7.22	7.02
Mode	8DPSK mode		
Channel/Frequency(MHz)	0(2402)	39(2441)	78(2480)
Peak Power(dBm)	8.64	7.36	7.07

The maximum output power of BLE is:

Mode	1Mbps		
Channel/Frequency(MHz)	0(2402)	19(2440)	39(2480)
Peak Power(dBm)	7.07	5.70	5.71
Mode	2Mbps		
Channel/Frequency(MHz)	0(2402)	19(2440)	39(2480)
Peak Power(dBm)	7.13	5.74	5.75





10.1.4 Tune-up powertolerance

Band	Tune-up power tolerance(dBm)			
WIFI	2.4G (MAIN ANT1)		802.11b	Max output power =17.0±1.0dbm
			802.11g	Max output power =20.5±1.0dbm
			802.11n (HT20)	Max output power =20.5±1.0dbm
			802.11n (HT40)	Max output power =20.5±1.0dbm
			802.11ax20	Max output power =20.5±1.0dbm
			802.11ax40)	Max output power =21.0±1.0dbm
	2.4G (AUX ANT2)		802.11b	Max output power =17.0±1.0dbm
			802.11g	Max output power =20.5±1.0dbm
			802.11n (HT20)	Max output power =20.0±1.0dbm
			802.11n (HT40)	Max output power =20.5±1.0dbm
			802.11ax20	Max output power =20.5±1.0dbm
			802.11ax40)	Max output power =20.5±1.0dbm
	2.4G (MIMOMode)		802.11n (HT20)	Max output power =23.5±1.0dbm
			802.11n (HT40)	Max output power =23.5±1.0dbm
			802.11ax20	Max output power =23.5±1.0dbm
		802.11ax40)	Max output power =24.0±1.0dbm	
U-NII-1 (5150-5250)	Ant 1	802.11n (HT40)	Max output power =12.0±1.0dbm	
	Ant 2	802.11n (HT40)	Max output power =14.0±1.0dbm	
	MIMO	802.11n (HT40)	Max output power =16.0±1.0dbm	
U-NII-2a (5250-5350)	Ant 1	802.11n(HT40)	Max output power =12.0±1.0dbm	
	Ant 2	802.11n(HT40)	Max output power =13.5±1.0dbm	
	MIMO	802.11n(HT40)	Max output power =16.0±1.0dbm	
U-NII-2c (5470-5725)	Ant 1	802.11n(VHT80)	Max output power =13.0±1.0dbm	
	Ant 2	802.11n(VHT80)	Max output power =15.5±1.0dbm	
	MIMO	802.11n(VHT80)	Max output power =17.5±1.0dbm	
U-NII-3 (5725-5825)	Ant 1	802.11n(HT40)	Max output power =13.0±1.0dbm	
	Ant 2	802.11n(HT40)	Max output power =14.5±1.0dbm	
	MIMO	802.11n(HT40)	Max output power =17.0±1.0dbm	
BT	GFSK mode		Max output power =10.5±1.0dbm	
	Pi/4DQPSK mode		Max output power =9.0±1.0dbm	
	8DPSK mode		Max output power =9.0±1.0dbm	
BLE	1Mbps Power		Max output power =7.5±1.0dbm	
	2Mbps Power		Max output power =7.5±1.0dbm	





10.2 SAR test results

Notes:

1) Per KDB447498 D01v05 r02, the SAR test shall be performed at the high, middle and low frequency channels of each operating mode. If the scaled SAR measured at mid-band channel for each test configuration is at least 3.0 dB lower than the SAR limit ($< 0.8 \text{ W/kg}$), testing at the high and low channels is optional.

2) Per KDB447498 D01v05r02, testing of other required channels within the operating mode of a frequency band is not required when the reported 1-g or 10-g SAR for the mid-band or highest output power channel is: $\leq 0.8 \text{ W/kg}$ or 2.0 W/kg , for 1-g or 10-g respectively, when the transmission band is $\leq 100 \text{ MHz}$. When the maximum output power variation across the required test channels is $> \frac{1}{2} \text{ dB}$, instead of the middle channel, the highest output power channel must be used.

3) Per KDB447498 D01v06, All measurement SAR result is scaled-up to account for tune-up tolerance is compliant.

4) Per KDB648474 D04v01r03, body-worn accessory testing is typically associated with voice operations. Therefore, GSM voice was evaluated for body-worn with headset SAR.

5) Per KDB248227 D01v02r02, the procedures required to establish specific device operating configurations for testing the SAR of 802.11 a/b/g transmitters.

6) Per KDB865664 D01v01r04, for each frequency band, repeated SAR measurement is required only when the measured SAR is $\geq 0.8 \text{ W/Kg}$; if the deviation among the repeated measurement is $\leq 20\%$, and the measured SAR $< 1.45 \text{ W/Kg}$, only one repeated measurement is required.

7) Per KDB865664 D02v01r02, SAR plot is only required for the highest measured SAR in each exposure configuration, wireless mode and frequency band combination; Plots are also required when the measured SAR is $> 1.5 \text{ W/kg}$, or $> 7.0 \text{ W/kg}$ for occupational exposure. The published RF exposure KDB procedures may require additional plots; for example, to support SAR to peak location separation ratio test exclusion and/or volume scan post-processing (Refer to appendix B for details).

8) Per KDB6162147 D04v01r02, the SAR requirements for laptop and tablet computers, and its to determine the minimum test separation distance .



10.2.1 Results overview of Wi-Fi 2.4G

Mode	Test Position of Body with 0mm	Test channel /Freq.(MHz)	SAR Value (W/kg)		Power Drift (%)	Conducted Power (dBm)	Tune-up Limit (dBm)	Scaled SAR1-g (W/kg)	Scaling Factor
			1-g	10-g					
WLAN2.4g(gap 0mm)									
802.11n (HT40) MAIN ANT1	Front	6/2437	0.181	0.076	-0.330	20.43	20.50	0.184	1.016
	Back	6/2437	0.197	0.082	-1.010	20.43	20.50	0.200	1.016
802.11ax 40 AUX ANT2	Front	6/2437	0.164	0.062	1.670	20.43	20.50	0.167	1.016
	Back	6/2437	0.190	0.084	-0.010	20.43	20.50	0.193	1.016
802.11ax 40 MIMO	Front	6/2437	0.180	0.076	3.510	23.52	24.00	0.201	1.117
	Back	6/2437	0.215	0.108	0.820	23.52	24.00	0.240	1.117





10.2.2 Results overview of Wi-Fi 5G

Mode	Test Position of Body with 0mm	Test channel /Freq.(MHz)	SAR Value (W/kg)		Power Drift (%)	Conducted Power (dBm)	Tune-up Limit (dBm)	Scaled SAR1-g (W/kg)	Scaling Factor
			1-g	10-g					
WLAN5.2g(gap 0mm)									
802.11n-HT40 ANT1	Front	46/5230	0.133	0.041	-3.910	11.75	12.00	0.141	1.059
	Back	46/5230	0.143	0.075	3.120	11.75	12.00	0.151	1.059
802.11n-HT40 ANT2	Front	46/5230	0.129	0.035	0.040	13.86	14.00	0.133	1.033
	Back	46/5230	0.142	0.061	-1.970	13.86	14.00	0.147	1.033
802.11n-HT40 MIMO-ANT	Front	46/5230	0.157	0.065	2.520	15.94	16.00	0.159	1.014
	Back	46/5230	0.170	0.088	-1.590	15.94	16.00	0.172	1.014
WLAN5.4g(gap 0mm)									
802.11n-HT40 ANT1	Front	54/5270	0.099	0.028	-0.180	11.58	12.00	0.109	1.102
	Back	54/5270	0.129	0.049	0.310	11.58	12.00	0.142	1.102
802.11n-HT40 ANT2	Front	54/5270	0.099	0.048	1.790	13.42	13.50	0.101	1.019
	Back	54/5270	0.117	0.042	-4.910	13.42	13.50	0.119	1.019
802.11n-HT40 MIMO-ANT	Front	54/5270	0.122	0.044	1.500	15.61	16.00	0.133	1.094
	Back	54/5270	0.146	0.070	3.690	15.61	16.00	0.160	1.094
WLAN5.6g(gap 0mm)									
802.11ac-VHT80 ANT1	Front	122/5610	0.090	0.034	-4.510	12.91	13.00	0.092	1.021
	Back	122/5610	0.126	0.036	3.810	12.91	13.00	0.129	1.021
802.11ac(VHT80) ANT2	Front	122/5610	0.078	0.014	-1.230	15.08	15.50	0.086	1.102
	Back	122/5610	0.118	0.050	4.610	15.08	15.50	0.130	1.102
802.11ac(VHT80) MIMO-ANT	Front	122/5610	0.116	0.026	0.690	17.14	17.50	0.126	1.086
	Back	122/5610	0.137	0.066	1.250	17.14	17.50	0.149	1.086
WLAN5.8g(gap 0mm)									
802.11n-HT40 ANT1	Front	151/5755	0.129	0.035	2.100	12.730	13.000	0.137	1.064
	Back	151/5755	0.149	0.052	2.480	12.730	13.000	0.159	1.064
802.11n-HT40 ANT2	Front	151/5755	0.121	0.026	-0.180	14.230	14.500	0.129	1.064
	Back	151/5755	0.142	0.053	-2.790	14.230	14.500	0.151	1.064
802.11n-HT40 MIMO-ANT1	Front	151/5755	0.138	0.040	2.480	16.550	17.000	0.153	1.109
	Back	151/5755	0.162	0.074	0.020	16.550	17.000	0.180	1.109



10.2.3 Results overview of BT

Test Position of Body with Omm	Test channel /Freq.(MHz)	Test Mode	SAR Value (W/kg)		Power Drift (%)	Conducted Power (dBm)	Tune-up Limit(dBm)	Scaled SAR _{1-g} (W/kg)	Scalig factor
			1-g	10-g					
BT antenna to side									
Front side	78/2480	GFSK	0.068	0.015	-1.500	10.30	10.50	0.071	1.047
Rear side	78/2480	GFSK	0.097	0.042	-1.550	10.30	10.50	0.102	1.047
Left side	78/2480	GFSK	0.085	0.021	-3.830	10.30	10.50	0.089	1.047
Top side	78/2480	GFSK	0.077	0.024	4.690	10.30	10.50	0.081	1.047





11 Multiple Transmitter Information

The SAR measurement positions of each side are as below:

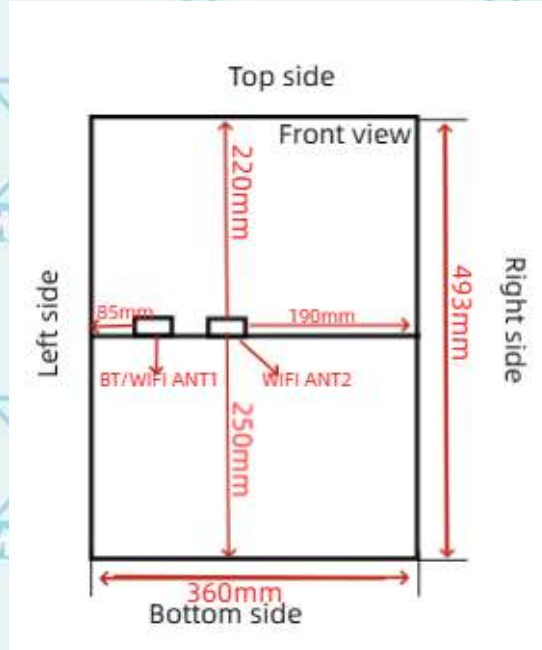

<Rear Side>

Side	Wi-Fi/BT antenna (0 degree) to Side
	SAR Consideration
Front Side	Yes
Rear Side	Yes
Left Side	Yes
Right Side	Yes
Top Side	Yes
Bottom Side	No

Note: According to section 6.1.4.5 device with swivel antennas, if the antennas can be rotated to two planes, an evaluation should be performed and documented on the report to decide the highest exposure conditions, and only that position need consideration.

In addition, in case of this antenna, the two representative positions 0degree and 90degree shall be evaluated independently for each required EUT edge. When evaluating the test surfaces, the nearest distance between the antenna and the edges is applicable.



11.1.1 Stand-alone SAR test exclusion

The 1-g and 10-g SAR test exclusion thresholds for 100 MHz to 6 GHz at test separation distances \leq 50 mm are determined by:

$[(\text{max. power of channel, including tune-up tolerance, mW}) / (\text{min. test separation distance, mm})] \cdot [\sqrt{f(\text{GHz})}] \leq 3.0$ for 1-g SAR and ≤ 7.5 for 10-g extremity SAR, where

- $f(\text{GHz})$ is the RF channel transmit frequency in GHz
- Power and distance are rounded to the nearest mW and mm before calculation
- The result is rounded to one decimal place for comparison

When the minimum test separation distance is < 5 mm, a distance of 5 mm is applied to determine SAR test exclusion.

Body-Worn position

Mode	Pmax(dBm)	Pmax(mW)	Distance(mm)	f(GHz)	Calculation Result	exclusion Threshold	SAR test exclusion
BT	10.30	10.72	5.00	2.45	3.35	7.50	Yes





11.1.2 Simultaneous Transmission SAR Summation Scenario

Mode	Position	Ant 1WIFI 1g(W/kg)	Ant 1 BT 1g(W/kg)	Ant 1 WIFI+ BT 1g(W/kg)
2.4Gwifi (MIMO)	Front	0.161	0.071	0.232
	Back	0.184	0.086	0.270
5.2Gwifi (MIMO)	Front	0.106	0.071	0.177
	Back	0.117	0.086	0.203
5.4Gwifi (MIMO)	Front	0.071	0.071	0.142
	Back	0.114	0.086	0.200
5.6Gwifi (MIMO)	Front	0.126	0.071	0.197
	Back	0.149	0.086	0.235
5.8Gwifi (MIMO)	Front	0.111	0.071	0.182
	Back	0.141	0.086	0.227





11.2 Measurement uncertainty evaluation for SAR test

The following table includes the uncertainty table of the IEEE 1528. The values are determined by Satimo. The breakdown of the individual uncertainties is as follows:

Measurement Uncertainty evaluation for SAR test								
Uncertainty Component	Tol. (±%)	Prob. Dist.	Div.	C _i (1g)	C _i (10g)	1g U _i (±%)	10g U _i (±%)	V _i
measurement system								
Probe Calibration	5.8	N	1	1	1	5.8	5.8	∞
Axial Isotropy	3.5	R	$\sqrt{3}$	$(1-C_p)^{1/2}$	$(1-C_p)^{1/2}$	1.43	1.43	∞
Hemispherical Isotropy	5.9	R	$\sqrt{3}$	$\sqrt{C_p}$	$\sqrt{C_p}$	2.41	2.41	∞
Boundary Effect	1	R	$\sqrt{3}$	1	1	0.58	0.58	∞
Linearity	4.7	R	$\sqrt{3}$	1	1	2.71	2.71	∞
system Detection Limits	1	R	$\sqrt{3}$	1	1	0.58	0.58	∞
Modulation response	3	N	1	1	1	3.00	3.00	∞
Readout Electronics	0.5	N	1	1	1	0.50	0.50	∞
Response Time	0	R	$\sqrt{3}$	1	1	0.00	0.00	∞
Integration Time	1.4	R	$\sqrt{3}$	1	1	0.81	0.81	∞
RF Ambient Conditions-Noise	3	R	$\sqrt{3}$	1	1	1.73	1.73	∞
RF Ambient Conditions-Reflections	3	R	$\sqrt{3}$	1	1	1.73	1.73	∞
Probe Positioner Mechanical Tolerance	1.4	R	$\sqrt{3}$	1	1	0.81	0.81	∞
Probe positioning with respect to Phantom Shell	1.4	R	$\sqrt{3}$	1	1	0.81	0.81	∞
Extrapolation, interpolation and Integration Algorithms for Max.SAR Evaluation	2.3	R	$\sqrt{3}$	1	1	1.33	1.33	∞
Test sample Related								
Test Sample Positioning	2.6	N	1	1	1	2.60	2.60	11
Device Holder Uncertainty	3	N	1	1	1	3.00	3.00	7
Output Power Variation-SAR drift measurement	5	R	$\sqrt{3}$	1	1	2.89	2.89	∞
SAR scaling	2	R	$\sqrt{3}$	1	1	1.15	1.15	∞



Phantom and Tissue Parameters								
Phantom Uncertainty (shape and thickness tolerances)	4	R	$\sqrt{3}$	1	1	2.31	2.31	∞
Uncertainty in SAR correction for deviation (in permittivity and conductivity)	2	N	1	1	0.84	2.00	1.68	∞
Liquid conductivity (meas.)	2.5	N	1	0.64	0.43	1.60	1.08	5
Liquid conductivity (target.)	5	R	$\sqrt{3}$	0.64	0.43	1.85	1.24	5
Liquid Permittivity (meas.)	2.5	N	1	0.60	0.49	1.50	1.23	∞
Liquid Permittivity (target.)	5	R	$\sqrt{3}$	0.60	0.49	1.73	1.42	∞
Combined Standard Uncertainty		Rss				10.63	10.54	
Expanded Uncertainty{95% CONFIDENCE INTERVAL}		k				21.26	21.08	





11.3 Measurement uncertainty evaluation for system check

The following table includes the uncertainty table of the IEEE 1528. The values are determined by Satimo. The breakdown of the individual uncertainties is as follows:

Uncertainty For System Performance Check								
Uncertainty Component	Tol. (±%)	Prob. Dist.	Div.	C _i 1g	C _i 10g	1g U _i (±%)	10g U _i (±%)	V _i
measurement system								
Probe Calibration	5.8	N	1	1	1	5.80	5.80	∞
Axial Isotropy	3.5	R	$\sqrt{3}$	$(1-C_p)^{1/2}$	$(1-C_p)^{1/2}$	1.43	1.43	∞
Hemispherical Isotropy	5.9	R	$\sqrt{3}$	$\sqrt{C_p}$	$\sqrt{C_p}$	2.41	2.41	∞
Boundary Effect	1	R	$\sqrt{3}$	1	1	0.58	0.58	∞
Linearity	4.7	R	$\sqrt{3}$	1	1	2.71	2.71	∞
system detection Limits	1	R	$\sqrt{3}$	1	1	0.58	0.58	∞
Modulation response	0	N	1	1	1	0.00	0.00	∞
Readout Electronics	0.5	N	1	1	1	0.50	0.50	∞
Response Time	0	R	$\sqrt{3}$	1	1	0.00	0.00	∞
Integration Time	1.4	R	$\sqrt{3}$	1	1	0.81	0.81	∞
RF ambient Conditions - Noise	3	R	$\sqrt{3}$	1	1	1.73	1.73	∞
RF ambient Conditions – Reflections	3	R	$\sqrt{3}$	1	1	1.73	1.73	∞
Probe positioned Mechanical Tolerance	1.4	R	$\sqrt{3}$	1	1	0.81	0.81	∞
Probe positioning with respect to Phantom Shell	1.4	R	$\sqrt{3}$	1	1	0.81	0.81	∞
Extrapolation, interpolation and integration Algorithms for Max. SAR Evaluation	2.3	R	$\sqrt{3}$	1	1	1.33	1.33	∞
Dipole								
Deviation of experimental source from numerical source	4	N	1	1	1	4.00	4.00	∞
Input power and SAR drift measurement	5	R	$\sqrt{3}$	1	1	2.89	2.89	∞
Dipole axis to liquid Distance	2	R	$\sqrt{3}$	1	1	1.16	1.16	∞



Phantom and Tissue Parameters								
Phantom Uncertainty (shape and thickness tolerances)	4	R	$\sqrt{3}$	1	1	2.31	2.31	∞
Uncertainty in SAR correction for deviation (in permittivity and conductivity)	2	N	1	1	0.84	2.00	1.68	∞
Liquid conductivity (meas.)	2.5	N	1	0.64	0.43	1.60	1.08	5
Liquid conductivity (target.)	5	R	$\sqrt{3}$	0.64	0.43	1.85	1.24	5
Liquid Permittivity (meas.)	2.5	N	1	0.60	0.49	1.50	1.23	∞
Liquid Permittivity (target.)	5	R	$\sqrt{3}$	0.60	0.49	1.73	1.41	∞
Combined Standard Uncertainty		Rss				10.28	9.98	
Expanded Uncertainty (95% Confidence interval)		k				20.57	19.95	





12 Test equipment and ancillaries used for tests

To simplify the identification of the test equipment and/or ancillaries which were used, the reporting of the relevant test cases only refer to the test item number as specified in the table below.

	Manufacturer	Device Type	Type(Model)	Serial number	calibration	
					Last Cal.	Due Date
<input checked="" type="checkbox"/>	SATIMO	COMOSAR DOSIMETRIC E FIELD PROBE	SSE2	3323-EPGO-424	2023-07-09	2024-07-08
<input checked="" type="checkbox"/>	SATIMO	COMOSAR 750 MHz REFERENCE DIPOLE	SID750	SN 48/16 DIP0G750-444	2023-06-25	2026-06-24
<input checked="" type="checkbox"/>	SATIMO	COMOSAR 835 MHz REFERENCE DIPOLE	SID835	SN 14/13 DIP0G835-235	2023-06-25	2026-06-24
<input checked="" type="checkbox"/>	SATIMO	COMOSAR 900 MHz REFERENCE DIPOLE	SID900	SN 14/13 DIP0G900-231	2023-06-25	2026-06-24
<input checked="" type="checkbox"/>	SATIMO	COMOSAR 1800 MHz REFERENCE DIPOLE	SID1800	SN 14/13 DIP1G800-232	2023-06-25	2026-06-24
<input type="checkbox"/>	SATIMO	COMOSAR 1900 MHz REFERENCE DIPOLE	SID1900	SN 14/13 DIP1G900-236	2023-06-25	2026-06-24
<input checked="" type="checkbox"/>	SATIMO	COMOSAR 2000 MHz REFERENCE DIPOLE	SID2000	SN 14/13 DIP2G000-237	2023-06-25	2026-06-24
<input checked="" type="checkbox"/>	SATIMO	COMOSAR 2450 MHz REFERENCE DIPOLE	SID2450	SN 14/13 DIP2G450-238	2023-06-25	2026-06-24
<input checked="" type="checkbox"/>	SATIMO	COMOSAR 2600 MHz REFERENCE DIPOLE	SID2600	SN 28/14 DIP2G600-327	2023-06-25	2026-06-24
<input checked="" type="checkbox"/>	SATIMO	Software	OPENSAR	N/A	N/A	N/A
<input checked="" type="checkbox"/>	SATIMO	Phantom	COMOSAR IEEE SAM PHANTOM	SN 14/13 SAM99	N/A	N/A
<input checked="" type="checkbox"/>	R & S	Universal Radio Communication Tester	CMU 200	119733	2023-11-02	2024-11-01
<input checked="" type="checkbox"/>	R & S	Universal Radio Communication Tester	CMW500	144459	2023-11-02	2024-11-01
<input checked="" type="checkbox"/>	R & S	Universal Radio Communication Tester	E7515B	MY60192341	2023-11-02	2024-11-01
<input checked="" type="checkbox"/>	HP	Network Analyser	8753D	3410A08889	2023-11-02	2024-11-01
<input checked="" type="checkbox"/>	HP	Signal Generator	E4421B	GB39340770	2023-11-02	2024-11-01
<input checked="" type="checkbox"/>	Keithley	Multimeter	Keithley 2000	4014539	2023-11-02	2024-11-01
<input checked="" type="checkbox"/>	SATIMO	Amplifier	Power Amplifier	MODU-023-A-0004	2023-11-02	2024-11-01
<input checked="" type="checkbox"/>	Agilent	Power Meter	E4418B	GB43312909	2023-11-02	2024-11-01
<input checked="" type="checkbox"/>	Agilent	Power Meter Sensor	E4412A	MY41500046	2023-11-02	2024-11-01



Annex A: System performance verification

(Please See the SAR Measurement Plots of annex A.)

Annex B: Measurement results

(Please See the SAR Measurement Plots of annex B.)

Annex C: Calibration reports

(Please See the Calibration reports of annex C.)

Annex D: Photographs



SATIMO 225, rue Pierre Rivoalon 29200 Brest - France
Tel:+33 (0)2 98 05 13 34; Fax: +33 (0)2 98 05 53 87; www.satimo.com



Annex A: System Check

Tested Model : T16MA

Report Number:

WSCT-A2LA-R&E240300013A-SAR

MEASUREMENT 1

BODY

Type: Validation measurement (Complete)

Date of measurement: 20/4/2024

Measurement duration: 10 minutes 43 seconds

A. Experimental conditions.

<u>Area Scan</u>	<u>dx=8mm dy=8mm</u>
<u>ZoomScan</u>	<u>5x5x7, dx=8mm dy=8mm dz=5mm, Complete</u>
<u>Phantom</u>	<u>Validation plane</u>
<u>Device Position</u>	<u>Dipole</u>
<u>Band</u>	<u>CW2450</u>
<u>Channels</u>	<u>Middle</u>
<u>Signal</u>	<u>CW (Crest factor: 1.0)</u>

B. SAR Measurement Results

Middle Band SAR (Channel -1):

Frequency (MHz)	2450.000000
Relative permittivity (real part)	52.735699
Relative permittivity (imaginary part)	14.017300
Conductivity (S/m)	1.907910
Variation (%)	0.390000

SURFACE SAR

VOLUME SAR

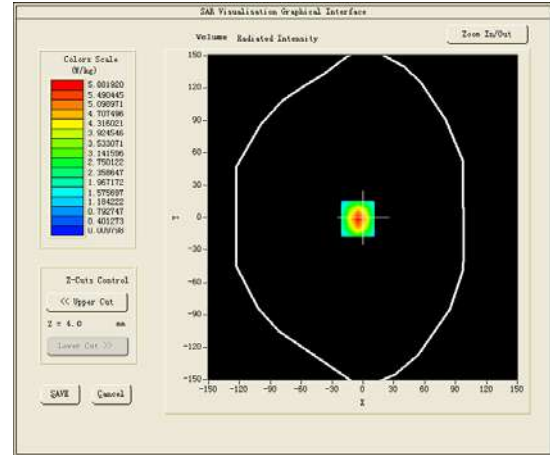
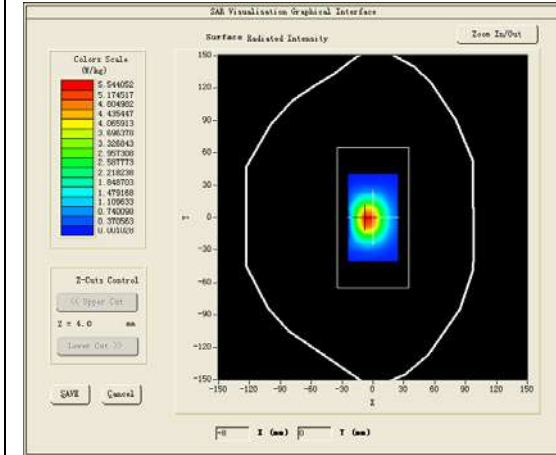

Maximum location: X=-5.00, Y=-1.00

SAR Peak: 10.96 W/kg

SAR 10g (W/Kg)	2.265453
SAR 1g (W/Kg)	5.363343

Z (mm)	0.00	4.00	9.00	14.00	19.00	24.00	29.00
SAR (W/Kg)	10.2188	5.8819	2.7478	1.3151	0.6266	0.2969	0.1341

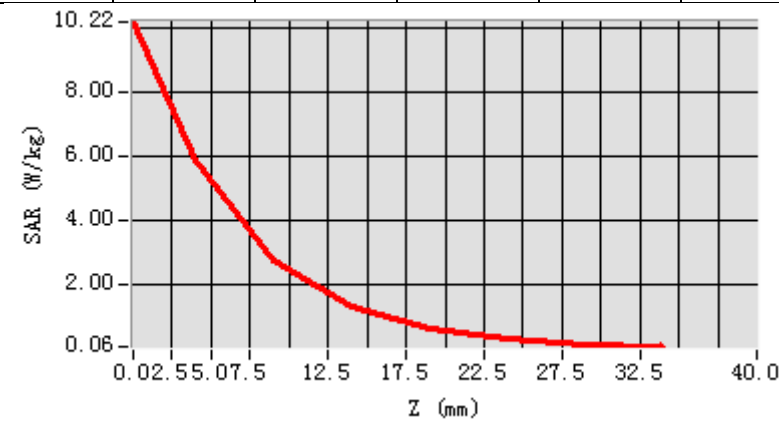

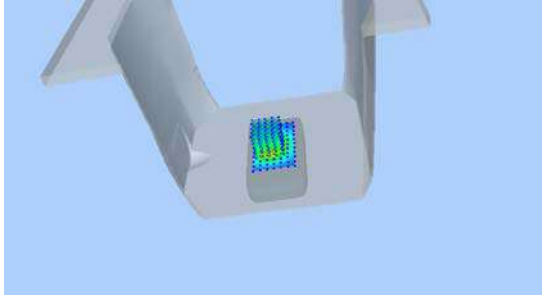
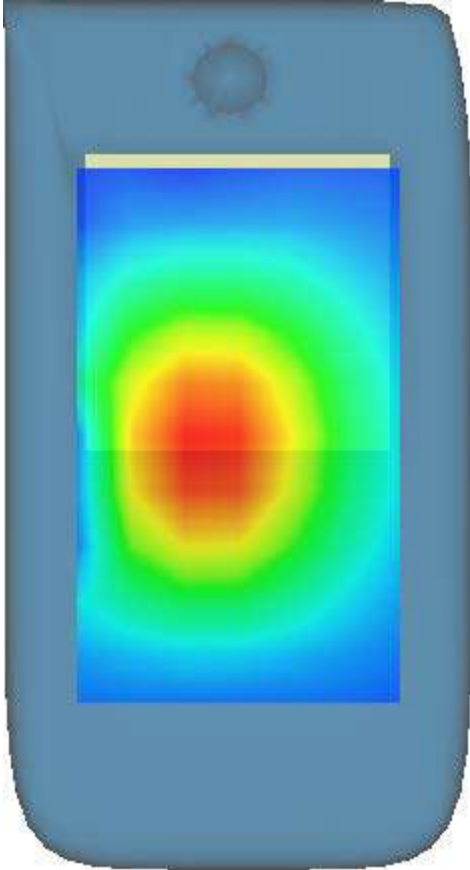
3D screen shot	Hot spot position
	

MEASUREMENT 2

BODY

Type: Validation measurement (Complete)

Date of measurement: 20/4/2024

Measurement duration: 27 minutes 45 seconds

A. Experimental conditions.

<u>Area Scan</u>	<u>dx=10mm dy=10mm</u>
<u>ZoomScan</u>	<u>8x8x7,dx=4mm dy=4mm</u> <u>dz=2mm,Complete</u>
<u>Phantom</u>	<u>Validation plane</u>
<u>Device Position</u>	<u>Waveguide</u>
<u>Band</u>	<u>CW5200</u>
<u>Channels</u>	<u>Middle</u>
<u>Signal</u>	<u>CW (Duty cycle:1:1)</u>

B. SAR Measurement Results

Middle Band SAR (Channel -1):

Frequency (MHz)	5200.000000
Relative permittivity (real part)	50.422599
Relative permittivity (imaginary part)	18.202492
Conductivity (S/m)	5.26371
Variation (%)	0.270000

SURFACE SAR

VOLUME SAR

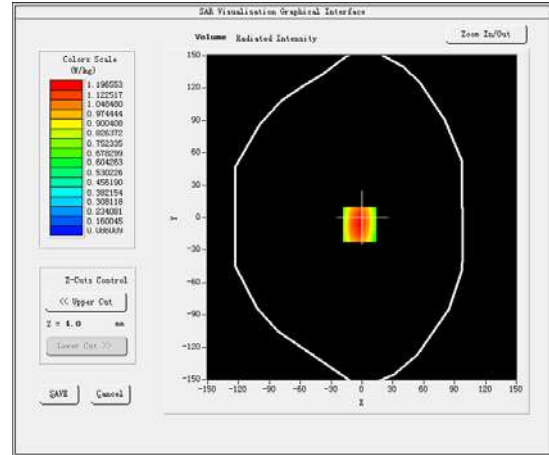
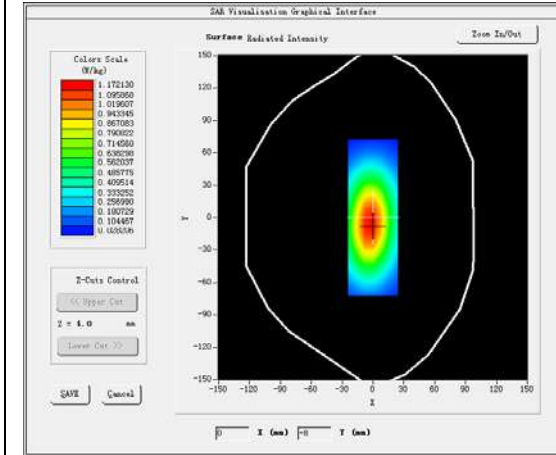

Maximum location: X=-2.00, Y=-6.00

SAR Peak: 20.27 W/kg

SAR 10g (W/Kg)	5.964061
SAR 1g (W/Kg)	16.7183141

Z (mm)	0.00	4.00	9.00	14.00	19.00	24.00	29.00
SAR (W/Kg)	20.2711	16.1966	12.7784	10.5196	8.1218	4.2403	1.1660

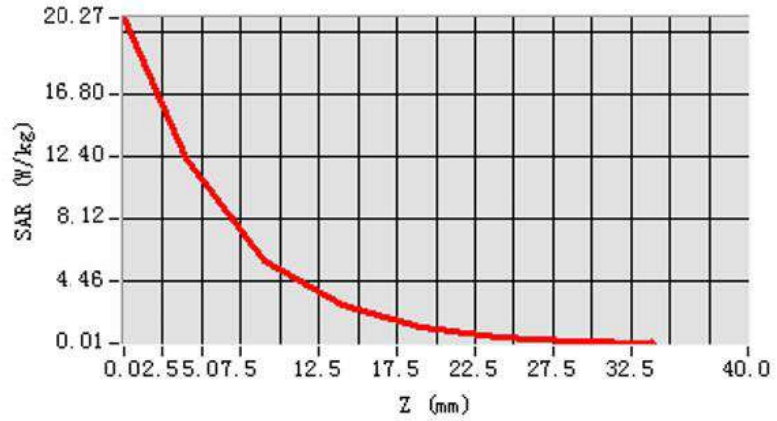

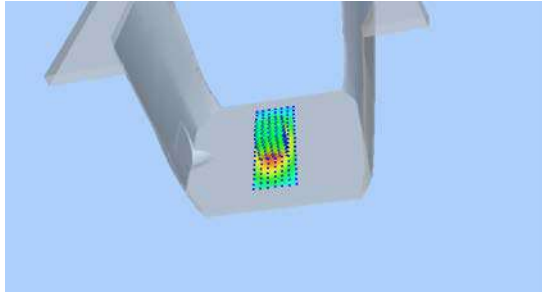
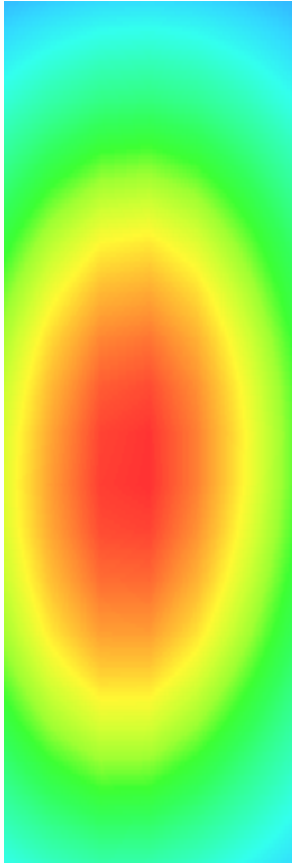
3D screen shot	Hot spot position
	

MEASUREMENT 3

BODY

Type: Validation measurement (Complete)

Date of measurement: 20/4/2024

Measurement duration: 29 minutes 31 seconds

A. Experimental conditions.

<u>Area Scan</u>	<u>dx=10mm dy=10mm</u>
<u>ZoomScan</u>	<u>8x8x7,dx=4mm dy=4mm dz=2mm,Complete</u>
<u>Phantom</u>	<u>Validation plane</u>
<u>Device Position</u>	<u>Waveguide</u>
<u>Band</u>	<u>CW5300</u>
<u>Channels</u>	<u>Middle</u>
<u>Signal</u>	<u>CW (Duty cycle:1:1)</u>

B. SAR Measurement Results

Middle Band SAR (Channel -1):

Frequency (MHz)	5300.000000
Relative permittivity (real part)	47.944300
Relative permittivity (imaginary part)	18.167566
Conductivity (S/m)	5.353919
Variation (%)	-0.350000

SURFACE SAR

VOLUME SAR

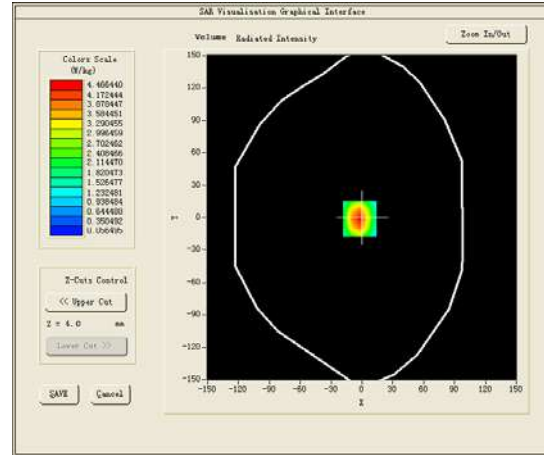
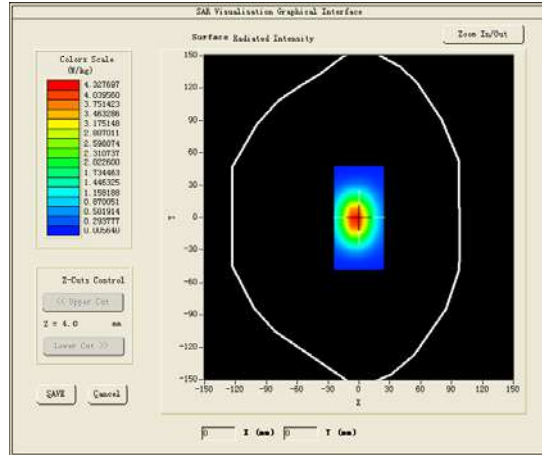

Maximum location: X=-2.00, Y=-1.00

SAR Peak: 20.27 W/kg

SAR 10g (W/Kg)	5.882155
SAR 1g (W/Kg)	16.537029

Z (mm)	0.00	4.00	9.00	14.00	19.00	24.00	29.00
SAR (W/Kg)	20.2697	16.4664	12.4603	10.3992	6.7963	4.4560	1.2601

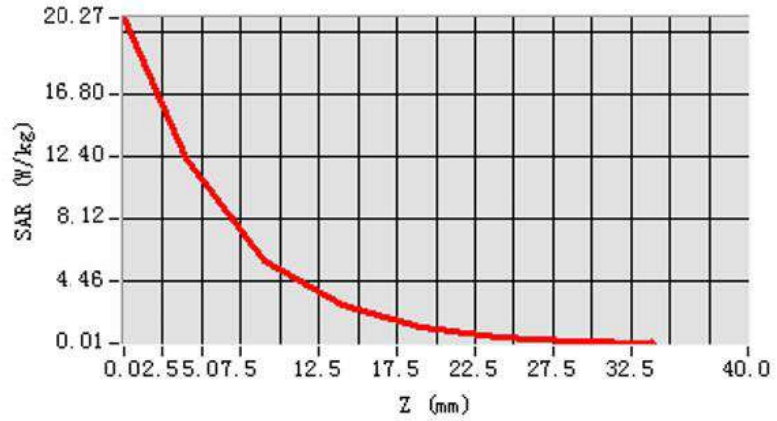

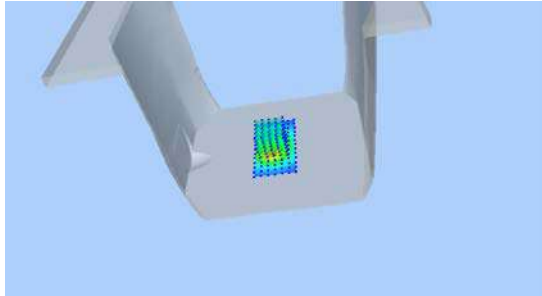
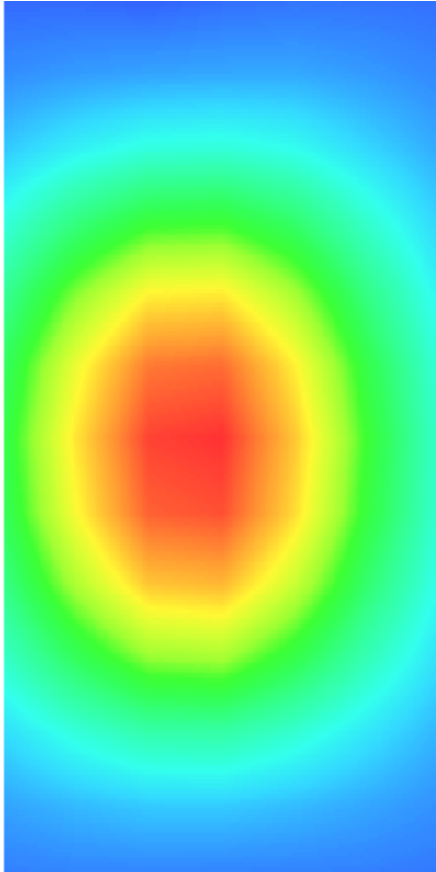
3D screen shot	Hot spot position
	

MEASUREMENT 4

BODY

Type: Validation measurement (Complete)

Date of measurement: 20/4/2024

Measurement duration: 31 minutes 30 seconds

A. Experimental conditions.

<u>Area Scan</u>	<u>dx=10mm dy=10mm</u>
<u>ZoomScan</u>	<u>8x8x7,dx=4mm dy=4mm</u> <u>dz=2mm,Complete</u>
<u>Phantom</u>	<u>Validation plane</u>
<u>Device Position</u>	<u>Waveguide</u>
<u>Band</u>	<u>CW5800</u>
<u>Channels</u>	<u>Middle</u>
<u>Signal</u>	<u>CW (Duty cycle:1:1)</u>

B. SAR Measurement Results

Middle Band SAR (Channel -1):

Frequency (MHz)	5800.000000
Relative permittivity (real part)	48.090699
Relative permittivity (imaginary part)	19.043921
Conductivity (S/m)	6.14163
Variation (%)	0.010000

SURFACE SAR

VOLUME SAR

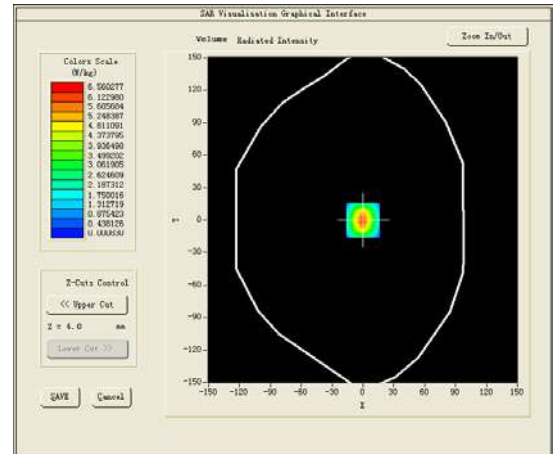
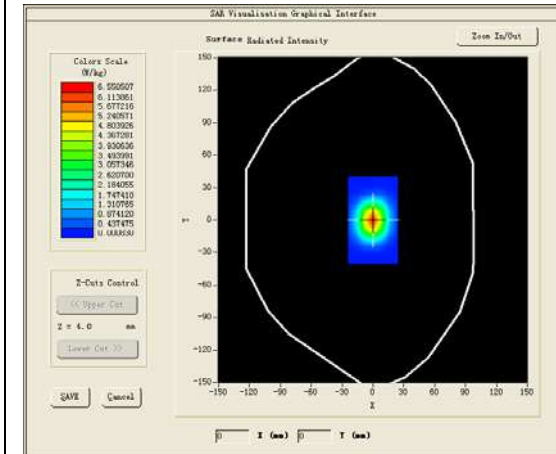

Maximum location: X=0.00, Y=0.00

SAR Peak: 20.41 W/kg

SAR 10g (W/Kg)	6.080196
SAR 1g (W/Kg)	17.965831

Z (mm)	0.00	4.00	9.00	14.00	19.00	24.00	29.00
SAR (W/Kg)	20.4140	16.5603	12.8797	8.2004	4.4226	2.1066	1.0008

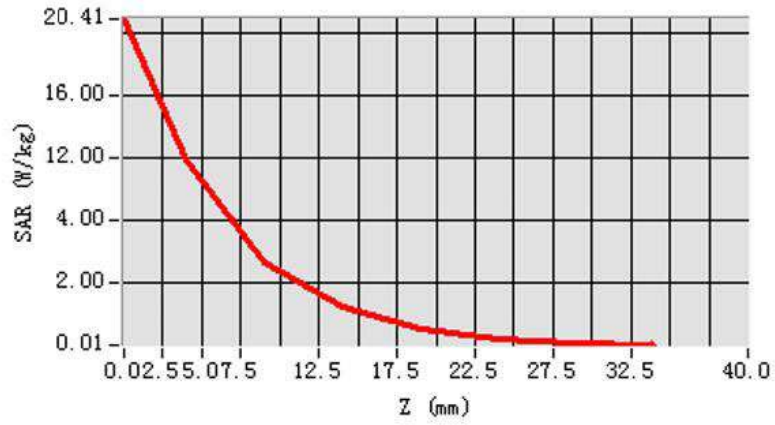

3D screen shot

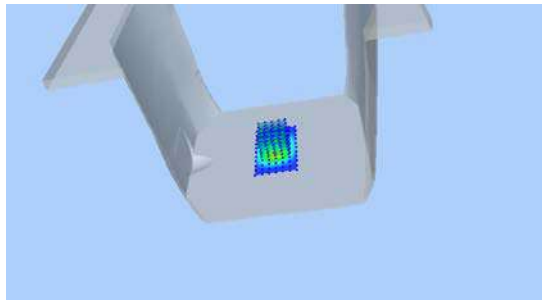

Hot spot position

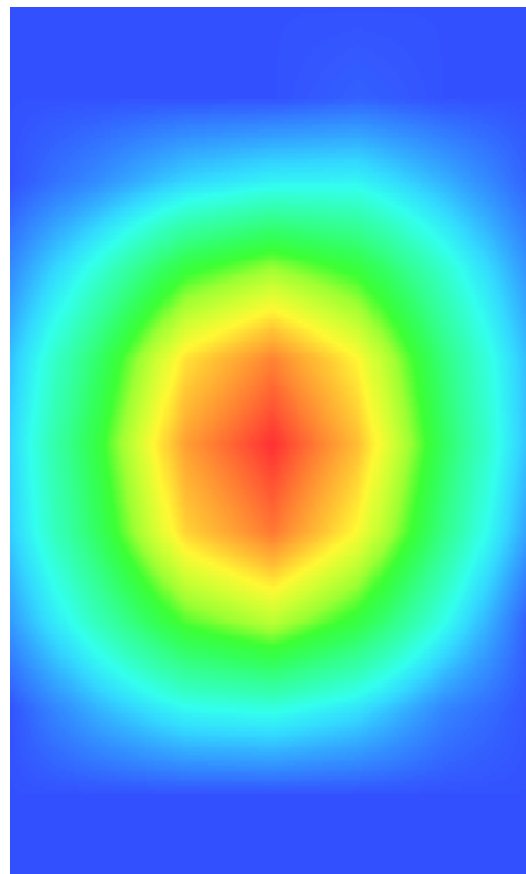



SATIMO 225, rue Pierre Rivoalon 29200 Brest - France
Tel:+33 (0)2 98 05 13 34; Fax: +33 (0)2 98 05 53 87; www.satimo.com



Annex B: Measurement Results

Tested Model :T16MA

Report Number:

WSCT-A2LA-R&E240300013A-SAR

MEASUREMENT 1

Rear-side-middle

Type: Phone measurement (Complete)

Date of measurement: 20/4/2024

Measurement duration: 11 minutes 11 seconds

A. Experimental conditions.

<u>Area Scan</u>	<u>dx=15mm dy=15mm</u>
<u>ZoomScan</u>	<u>7x7x7,dx=5mm dy=5mm</u> <u>dz=5mm,Complete</u>
<u>Phantom</u>	<u>Validation plane</u>
<u>Device Position</u>	<u>Body</u>
<u>Band</u>	<u>IEEE 802.11b ISM</u>
<u>Channels</u>	<u>Middle</u>
<u>Signal</u>	<u>IEEE802.b (Crest factor: 1.0)</u>

B. SAR Measurement Results

Middle Band SAR (Channel 6):

Frequency (MHz)	2437.000000
Relative permittivity (real part)	52.756401
Relative permittivity (imaginary part)	14.076200
Conductivity (S/m)	1.909671
Variation (%)	0.820000

SURFACE SAR

VOLUME SAR

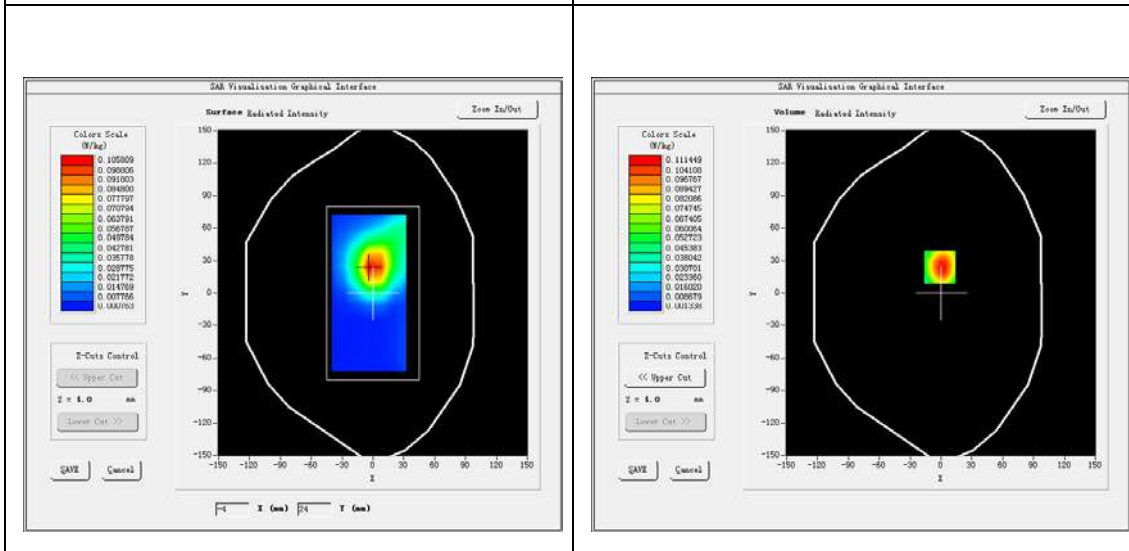

Maximum location: X=-1.00, Y=24.00

SAR Peak: 0.16 W/kg

SAR 10g (W/Kg)	0.108365
SAR 1g (W/Kg)	0.215324

Z (mm)	0.00	4.00	9.00	14.00	19.00	24.00	29.00
SAR (W/Kg)	0.1801	0.1114	0.0587	0.0309	0.0161	0.0083	0.0040

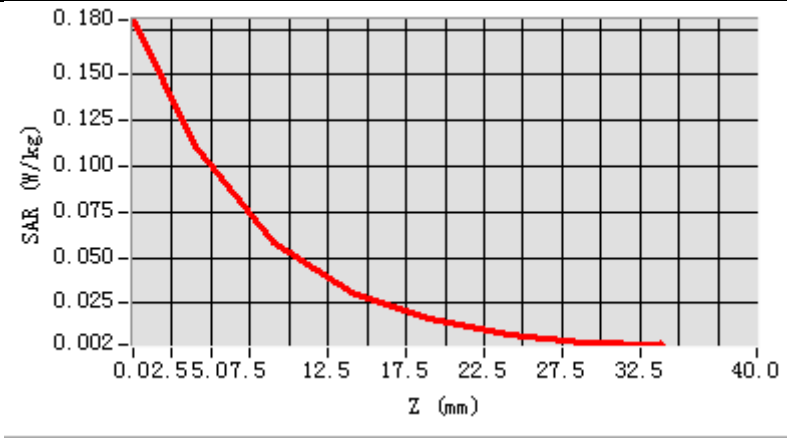

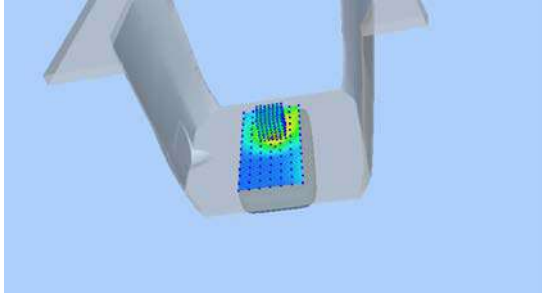
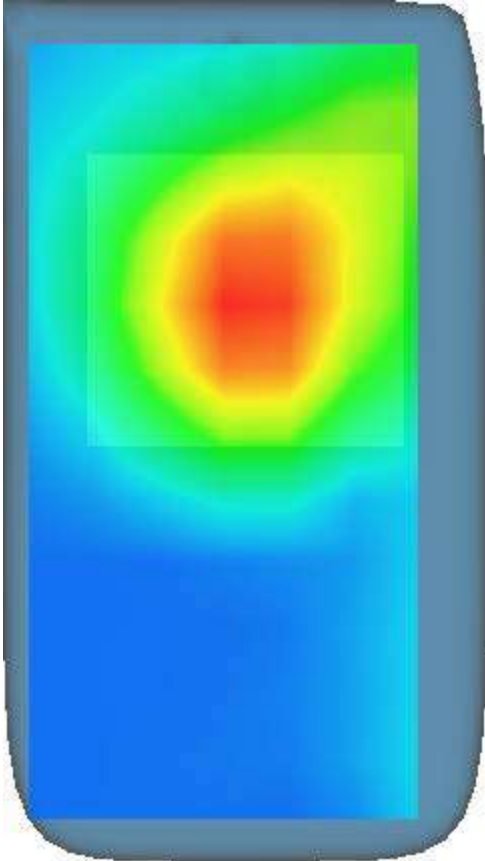
3D screen shot	Hot spot position
	

MEASUREMENT 2

Rear-side-middle

Type: Phone measurement (Complete)

Date of measurement: 20/4/2024

Measurement duration: 10 minutes 44 seconds

A. Experimental conditions.

<u>Area Scan</u>	<u>dx=10mm dy=10mm</u>
<u>ZoomScan</u>	<u>7x7x12,dx=4mm dy=4mm</u> <u>dz=2mm,Complete</u>
<u>Phantom</u>	<u>Validation plane</u>
<u>Device Position</u>	<u>Body</u>
<u>Band</u>	<u>IEEE 802.11a U-NII-1</u>
<u>Channels</u>	<u>Middle</u>
<u>Signal</u>	<u>Duty cycle:1:1</u>

B. SAR Measurement Results

Lower Band SAR (Channel 46):

Frequency (MHz)	5230.000000
Relative permittivity (real part)	49.858526
Relative permittivity (imaginary part)	17.828438
Conductivity (S/m)	5.194532
Variation (%)	-1.590000

SURFACE SAR

VOLUME SAR

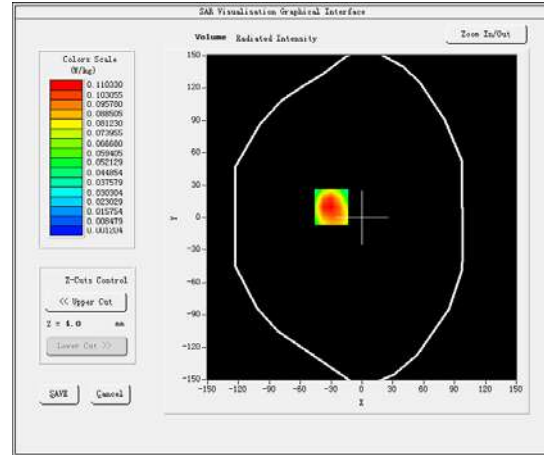
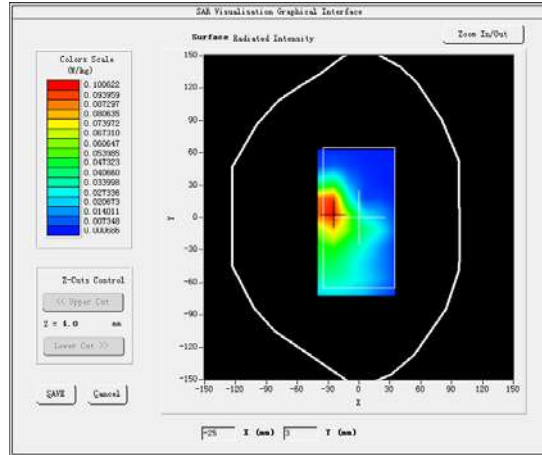

Maximum location: X=-30.00, Y=10.00

SAR Peak: 0.19 W/kg

SAR 10g (W/Kg)	0.088034
SAR 1g (W/Kg)	0.170037

Z (mm)	0.00	4.00	9.00	14.00	19.00	24.00	29.00
SAR (W/Kg)	0.1788	0.1103	0.0576	0.0303	0.0156	0.0075	0.0040

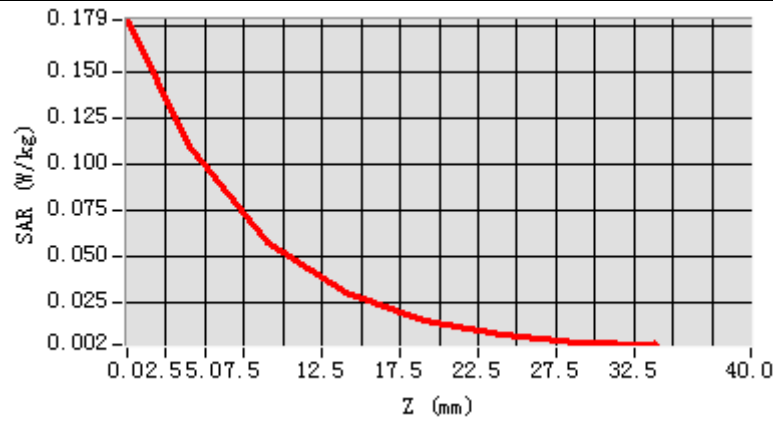

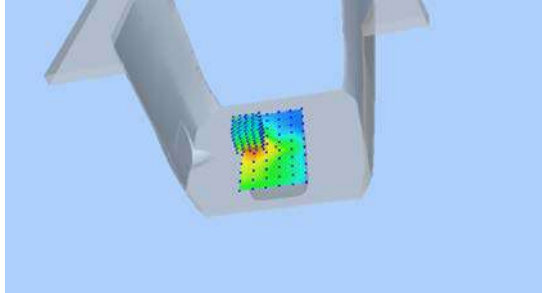
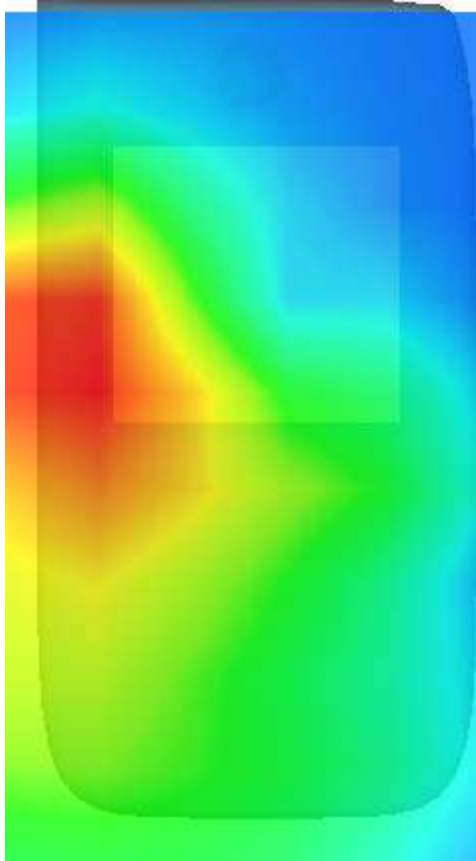
3D screen shot	Hot spot position
	

MEASUREMENT 3

Rear-side-middle

Type: Phone measurement (Complete)

Date of measurement: 20/4/2024

Measurement duration: 16 minutes 21 seconds

A. Experimental conditions.

<u>Area Scan</u>	<u>dx=10mm dy=10mm</u>
<u>ZoomScan</u>	<u>7x7x12,dx=4mm dy=4mm dz=2mm,Complete</u>
<u>Phantom</u>	<u>Validation plane</u>
<u>Device Position</u>	<u>Body</u>
<u>Band</u>	<u>IEEE 802.11a U-NII-2a</u>
<u>Channels</u>	<u>Middle</u>
<u>Signal</u>	<u>Duty cycle:1:1</u>

B. SAR Measurement Results

Middleer Band SAR (Channel 54):

Frequency (MHz)	5270.000000
Relative permittivity (real part)	48.139400
Relative permittivity (imaginary part)	19.154900
Conductivity (S/m)	6.205808
Variation (%)	3.690000

SURFACE SAR

VOLUME SAR

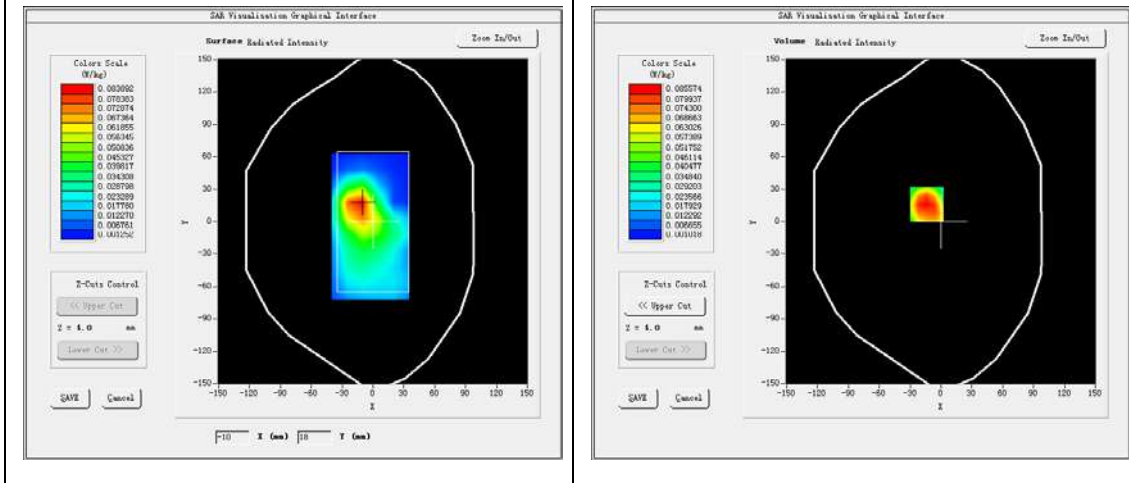

Maximum location: X=-14.00, Y=16.00

SAR Peak: 0.15 W/kg

SAR 10g (W/Kg)	0.070350
SAR 1g (W/Kg)	0.146034

Z (mm)	0.00	4.00	9.00	14.00	19.00	24.00	29.00
SAR (W/Kg)	0.1388	0.0856	0.0441	0.0224	0.0109	0.0049	0.0027

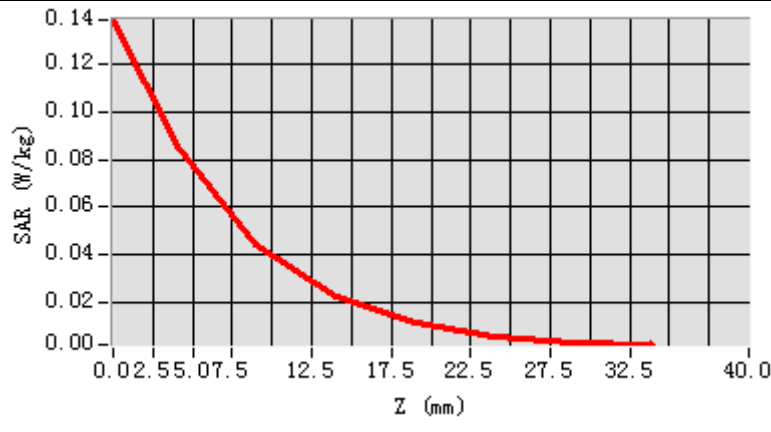

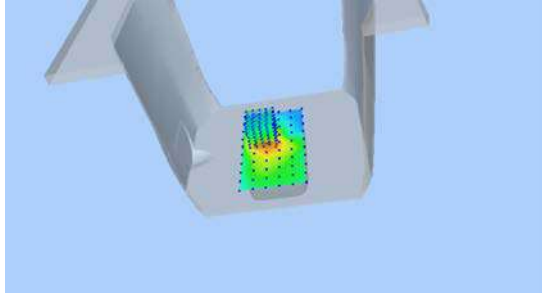
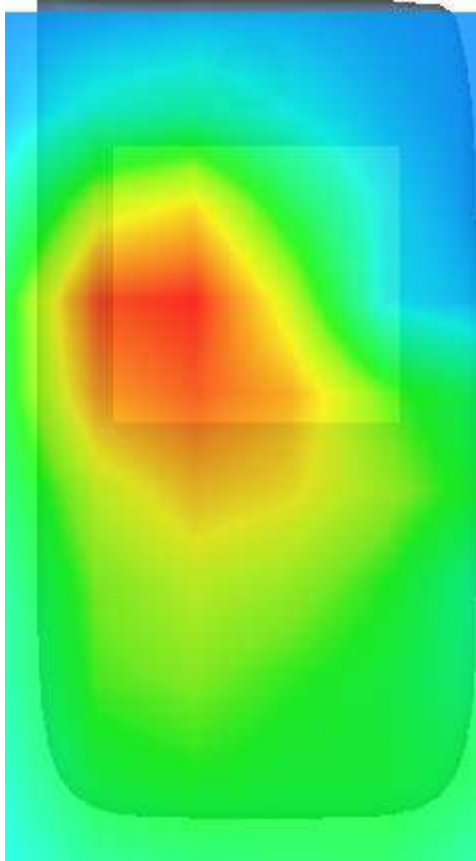
3D screen shot	Hot spot position
	

MEASUREMENT 4

Rear-side-middle

Type: Phone measurement (Complete)

Date of measurement: 20/4/2024

Measurement duration: 8 minutes 31 seconds

A. Experimental conditions.

<u>Area Scan</u>	<u>dx=10mm dy=10mm</u>
<u>ZoomScan</u>	<u>7x7x12,dx=4mm dy=4mm dz=2mm,Complete</u>
<u>Phantom</u>	<u>Validation plane</u>
<u>Device Position</u>	<u>Body</u>
<u>Band</u>	<u>IEEE 802.11a U-NII-2c</u>
<u>Channels</u>	<u>Middle</u>
<u>Signal</u>	<u>Duty cycle:1:1</u>

B. SAR Measurement Results

Middleer Band SAR (Channel 122):

Frequency (MHz)	5610.000000
Relative permittivity (real part)	48.235748
Relative permittivity (imaginary part)	19.060800
Conductivity (S/m)	6.173560
Variation (%)	1.250000

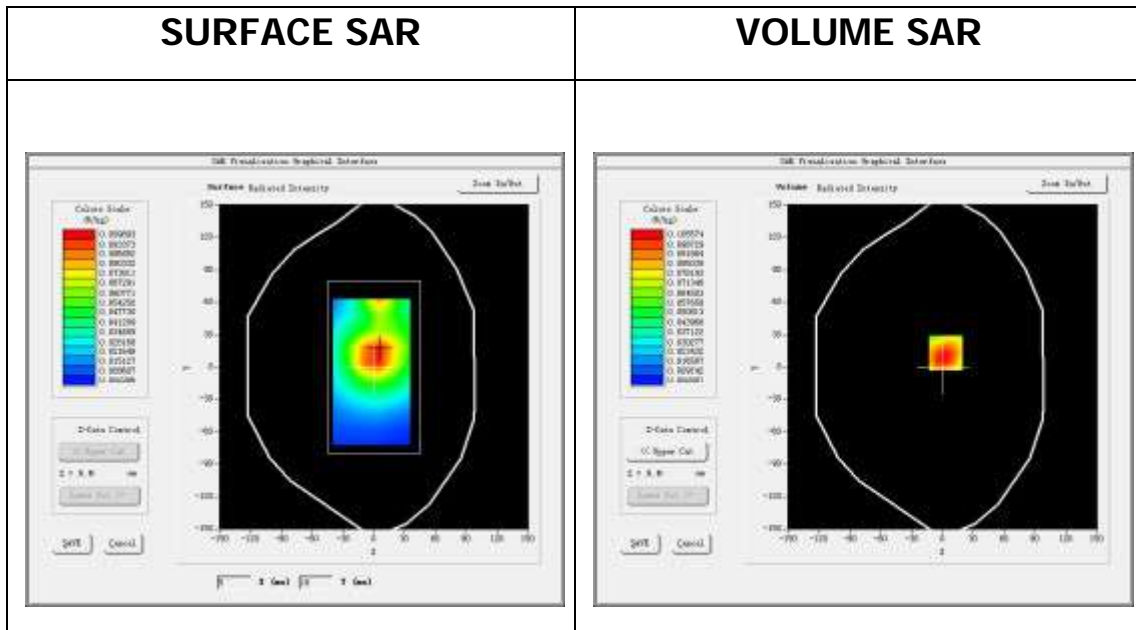

Maximum location: X=3.00, Y=13.00

SAR Peak: 0.17 W/kg

SAR 10g (W/Kg)	0.066370
SAR 1g (W/Kg)	0.137204

Z (mm)	0.00	4.00	9.00	14.00	19.00	24.00	29.00
SAR (W/Kg)	0.5035	0.2644	0.1036	0.0539	0.0226	0.0107	0.0050

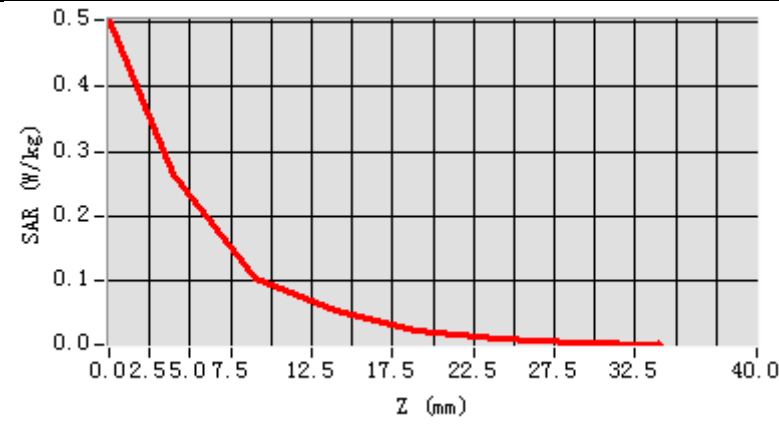

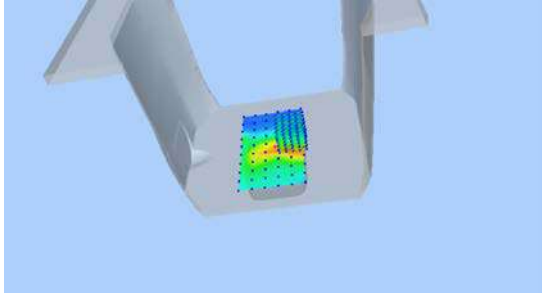
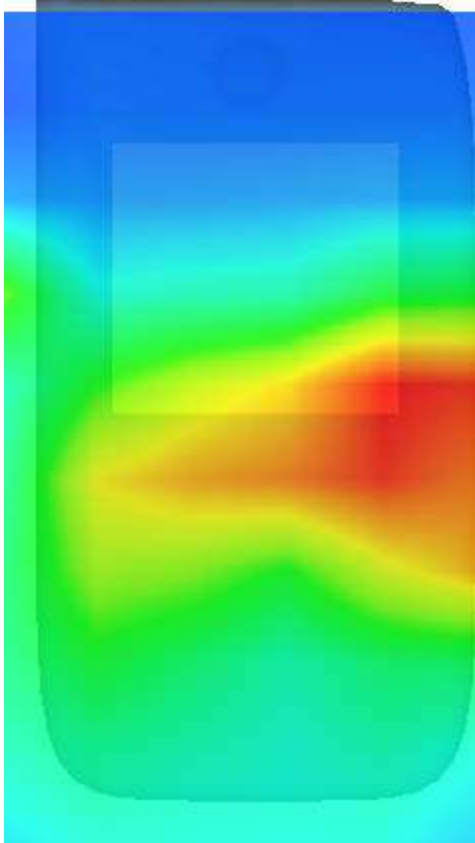
3D screen shot	Hot spot position
	

MEASUREMENT 5

Rear-side-middle

Type: Phone measurement (Complete)

Date of measurement: 20/4/2024

Measurement duration: 8 minutes 31 seconds

A. Experimental conditions.

<u>Area Scan</u>	<u>dx=10mm dy=10mm</u>
<u>ZoomScan</u>	<u>7x7x12,dx=4mm dy=4mm dz=2mm,Complete</u>
<u>Phantom</u>	<u>Validation plane</u>
<u>Device Position</u>	<u>Body</u>
<u>Band</u>	<u>IEEE 802.11a U-NII-3</u>
<u>Channels</u>	<u>Middle</u>
<u>Signal</u>	<u>Duty cycle:1:1</u>

B. SAR Measurement Results

Middleer Band SAR (Channel 149):

Frequency (MHz)	5745.000000
Relative permittivity (real part)	48.235748
Relative permittivity (imaginary part)	19.060800
Conductivity (S/m)	6.173560
Variation (%)	0.020000

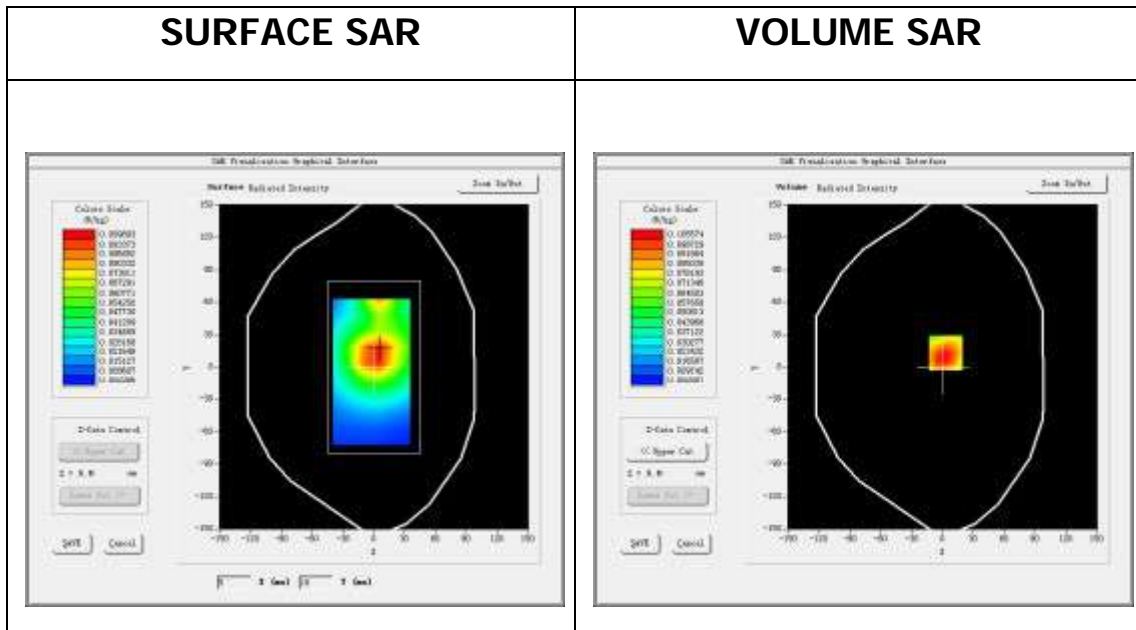

Maximum location: X=3.00, Y=13.00

SAR Peak: 0.17 W/kg

SAR 10g (W/Kg)	0.074305
SAR 1g (W/Kg)	0.162054

Z (mm)	0.00	4.00	9.00	14.00	19.00	24.00	29.00
SAR (W/Kg)	0.5035	0.2644	0.1036	0.0539	0.0226	0.0107	0.0050

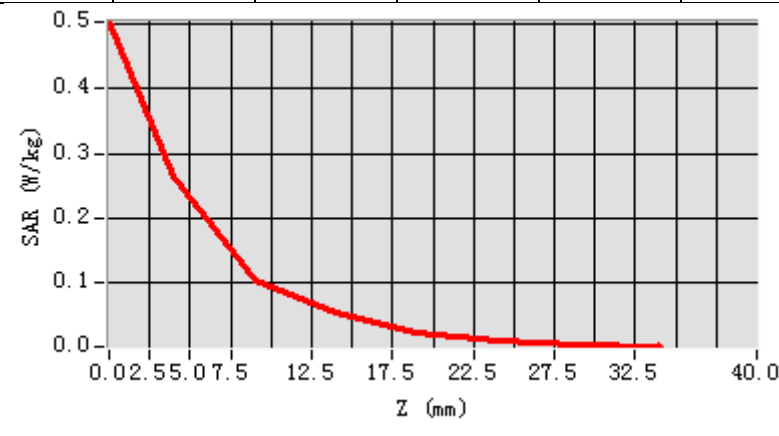

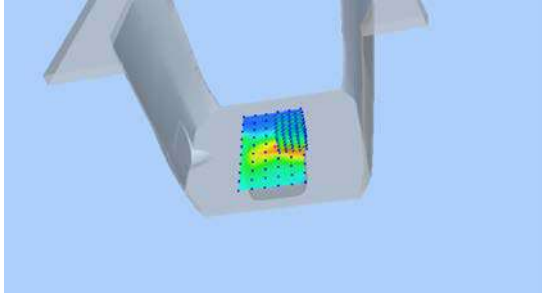
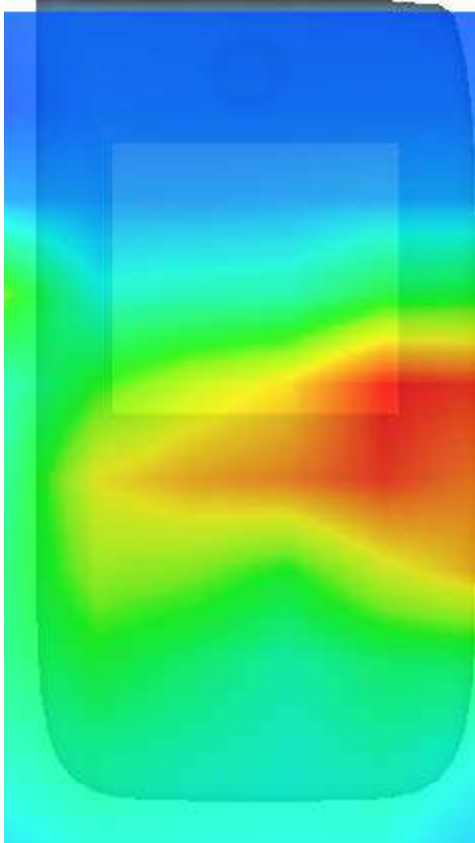
3D screen shot	Hot spot position
	

MEASUREMENT 6

Type: Phone measurement (Complete)

Date of measurement: 20/4/2024

Measurement duration: 11 minutes 11 seconds

A. Experimental conditions.

<u>Area Scan</u>	<u>dx=15mm dy=15mm</u>
<u>ZoomScan</u>	<u>7x7x7, dx=5mm dy=5mm dz=5mm, Complete</u>
<u>Phantom</u>	<u>Validation plane</u>
<u>Device Position</u>	<u>Body</u>
<u>Band</u>	<u>Bluetooth</u>
<u>Channels</u>	<u>High</u>
<u>Signal</u>	<u>Bluetooth (Crest factor: 1.0)</u>

B. SAR Measurement Results

Middle Band SAR (Channel 78):

Frequency (MHz)	2480.000000
Relative permittivity (real part)	39.160000
Relative permittivity (imaginary part)	13.290000
Conductivity (S/m)	1.831067
Variation (%)	-1.550000

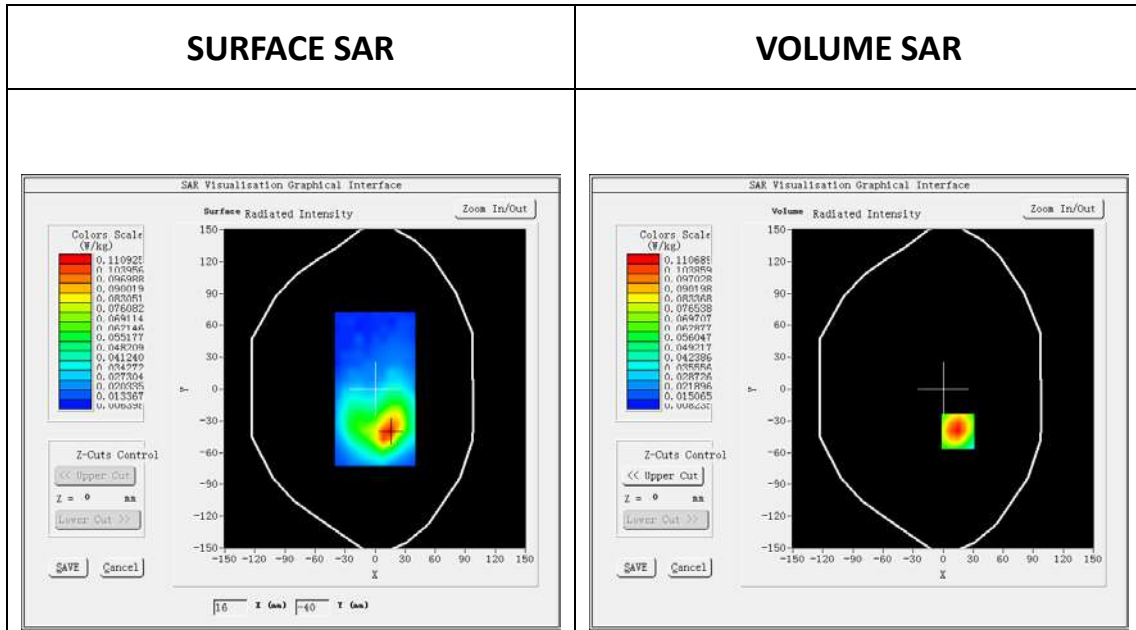

Maximum location: X=15.00, Y=-40.00

SAR Peak: 0.18 W/kg

SAR 10g (W/Kg)	0.042021
SAR 1g (W/Kg)	0.097230

Z (mm)	0.00	4.00	9.00	14.00	19.00	24.00	29.00
SAR (W/Kg)	0.1801	0.1114	0.0587	0.0309	0.0161	0.0083	0.0040

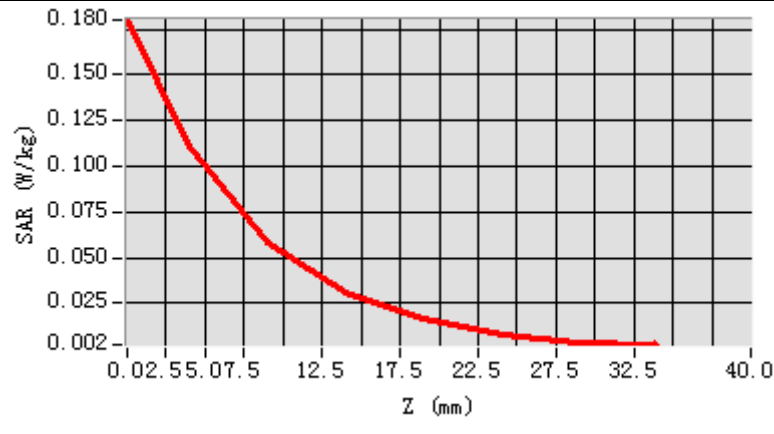

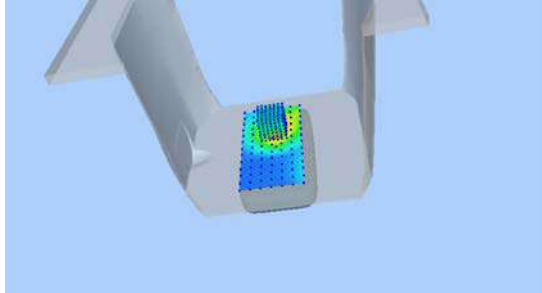
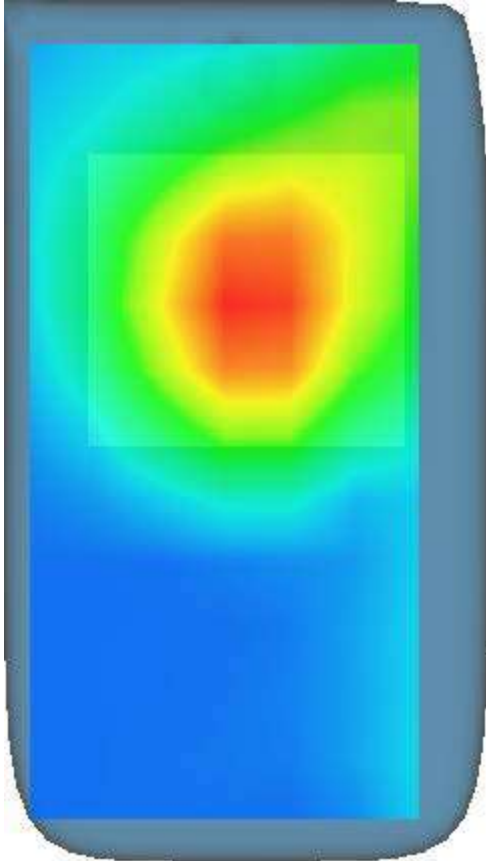
3D screen shot	Hot spot position
	



Annex C: Calibration Reports

Tested Model : T16MA

Report Number:

WSCT-A2LA-R&E240300013A-SAR



SAR Reference Dipole Calibration Report

Ref : ACR.313.16.23.BES.A

WORLD STANDARDIZATION CERTIFICATION & TESTING GROUP CO.,LTD

BLOCK A, BAO SHI SCIENCE PARK, BAO SHI ROAD,
BAO'AN DISTRICT

SHENZHEN 518108, P.R. CHINA

MVG COMOSAR REFERENCE DIPOLE

FREQUENCY: 2450 MHZ

SERIAL NO.: 3723-DIP2G450-738

Calibrated at MVG

Z.I. de la pointe du diable

Technopôle Brest Iroise – 295 avenue Alexis de Rochon

29280 PLOUZANE - FRANCE

Calibration date: 09/11/2023



Accreditations #2-6789 and #2-6814
Scope available on www.cofrac.fr

The use of the Cofrac brand and the accreditation references is prohibited from any reproduction.

Summary:

This document presents the method and results from an accredited SAR reference dipole calibration performed in MVG using the COMOSAR test bench. All calibration results are traceable to national metrology institutions.



	<i>Name</i>	<i>Function</i>	<i>Date</i>	<i>Signature</i>
<i>Prepared by :</i>	Cyrille ONNEE	Measurement Responsible	11/9/2023	
<i>Checked & approved by:</i>	Jérôme Luc	Technical Manager	11/9/2023	
<i>Authorized by:</i>	Yann Toutain	Laboratory Director	11/9/2023	

Yann
Toutain ID

Signature
numérique de Yann
Toutain ID
Date: 2023.11.09
16:44:40 +01'00'

	<i>Customer Name</i>
<i>Distribution :</i>	World Standardization Certification & Testing Group Co ,Ltd

<i>Issue</i>	<i>Name</i>	<i>Date</i>	<i>Modifications</i>
A	Cyrille ONNEE	11/9/2023	Initial release



TABLE OF CONTENTS

1 Introduction..... 4

2 Device Under Test 4

3 Product Description 4

 3.1 General Information 4

4 Measurement Method 5

 4.1 Mechanical Requirements 5

 4.2 S11 parameter Requirements 5

 4.3 SAR Requirements 5

5 Measurement Uncertainty..... 5

 5.1 Mechanical dimensions 5

 5.2 S11 Parameter 5

 5.3 SAR 5

6 Calibration Results..... 6

 6.1 Mechanical Dimensions 6

 6.2 S11 parameter 6

 6.3 SAR 6

7 List of Equipment 8

1 INTRODUCTION

This document contains a summary of the requirements set forth by the IEC/IEEE 62209-1528 and FCC KDB865664 D01 standards for reference dipoles used for SAR measurement system validations and the measurements that were performed to verify that the product complies with the fore mentioned standards.

2 DEVICE UNDER TEST

Device Under Test	
Device Type	COMOSAR 2450 MHz REFERENCE DIPOLE
Manufacturer	MVG
Model	SID2450
Serial Number	3723-DIP2G450-738
Product Condition (new / used)	New

3 PRODUCT DESCRIPTION

3.1 GENERAL INFORMATION

MVG's COMOSAR Validation Dipoles are built in accordance to the IEC/IEEE 62209-1528 and FCC KDB865664 D01 standards. The product is designed for use with the COMOSAR test bench only.



Figure 1 – MVG COMOSAR Validation Dipole

4 MEASUREMENT METHOD

4.1 MECHANICAL REQUIREMENTS

The IEC/IEEE 62209-1528 and FCC KDB865664 D01 standards specify the mechanical components and dimensions of the validation dipoles, with the dimension's frequency and phantom shell thickness dependent. The COMOSAR test bench employs a 2 mm phantom shell thickness therefore the dipoles sold for use with the COMOSAR test bench comply with the requirements set forth for a 2 mm phantom shell thickness. A direct method is used with a ISO17025 calibrated caliper.

4.2 S11 PARAMETER REQUIREMENTS

The dipole used for SAR system validation measurements and checks must have a S11 of -20 dB or better. The S11 measurement shall be performed against a liquid filled flat phantom, with the phantom constructed as outlined in the fore mentioned standards. A direct method is used with a network analyser and its calibration kit, both with a valid ISO17025 calibration.

4.3 SAR REQUIREMENTS

The IEC/IEEE 62209-1528 and FCC KDB865664 D01 standards provide requirements for reference dipoles used for system validation measurements. The following measurements were performed to verify that the product complies with the fore-mentioned standards.

5 MEASUREMENT UNCERTAINTY

5.1 MECHANICAL DIMENSIONS

For the measurement in the range 0-300mm, the estimated expanded uncertainty (k=2) in calibration for the dimension measurement in mm is +/-0.20 mm with respect to measurement conditions.

For the measurement in the range 300-450mm, the estimated expanded uncertainty (k=2) in calibration for the dimension measurement in mm is +/-0.44 mm with respect to measurement conditions.

5.2 S11 PARAMETER

The estimated expanded uncertainty (k=2) in calibration for the S11 parameter in linear is +/-0.08 with respect to measurement conditions.

5.3 SAR

The guidelines outlined in the IEC/IEEE 62209-1528 and FCC KDB865664 D01 standards were followed to generate the measurement uncertainty for validation measurements.

The estimated expanded uncertainty (k=2) in calibration for the 1g and 10g SAR measurement in W/kg is +/-19% with respect to measurement conditions.

6 CALIBRATION RESULTS

6.1 MECHANICAL DIMENSIONS

L mm		h mm		d mm	
Measured	Required	Measured	Required	Measured	Required
51.74	51.50 +/- 2%	30.50	30.40 +/- 2%	3.60	3.60 +/- 2%

6.2 S11 PARAMETER

6.2.1 S11 parameter in Head Liquid

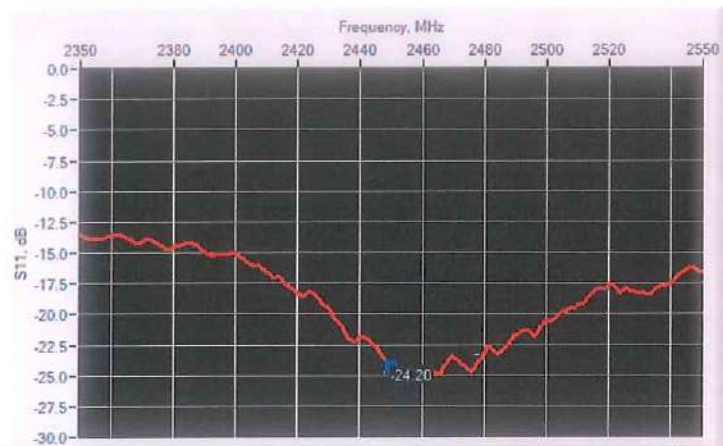

Frequency (MHz)	S11 parameter (dB)	Requirement (dB)	Impedance
2450	-24.20	-20	46.4Ω + 4.7jΩ

6.3 SAR

The IEC/IEEE 62209-1528 and FCC KDB865664 D01 standards state that the system validation measurements must be performed using a reference dipole meeting the fore mentioned return loss and mechanical dimension requirements. The validation measurement must be performed against a liquid filled flat phantom, with the phantom constructed as outlined in the fore mentioned standards. Per the standards, the dipole shall be positioned below the bottom of the phantom, with the dipole length centered and parallel to the longest dimension of the flat phantom, with the top surface of the dipole at the described distance from the bottom surface of the phantom.

6.3.1 SAR with Head Liquid

The IEC/IEEE 62209-1528 and FCC KDB865664 D01 standards state that the system validation measurements should produce the SAR values shown below (for phantom thickness of 2 mm), within the uncertainty for the system validation. All SAR values are normalized to 1 W forward power. In bracket, the measured SAR is given with the used input power.

Software	OPENSAR V5
Phantom	SN 13/09 SAM68
Probe	SN 41/18 EPGO333
Liquid	Head Liquid Values: eps' : 42.8 sigma : 1.87
Distance between dipole center and liquid	10.0 mm
Area scan resolution	dx=8mm/dy=8mm
Zoon Scan Resolution	dx=5mm/dy=5mm/dz=5mm
Frequency	2450 MHz
Input power	20 dBm
Liquid Temperature	20 +/- 1 °C
Lab Temperature	20 +/- 1 °C
Lab Humidity	30-70 %

Frequency	1g SAR (W/kg)			10g SAR (W/kg)		
	Measured	Measured normalized to 1W	Target normalized to 1W	Measured	Measured normalized to 1W	Target normalized to 1W
2450 MHz	5.33	53.30	52.40	2.51	25.11	24.00

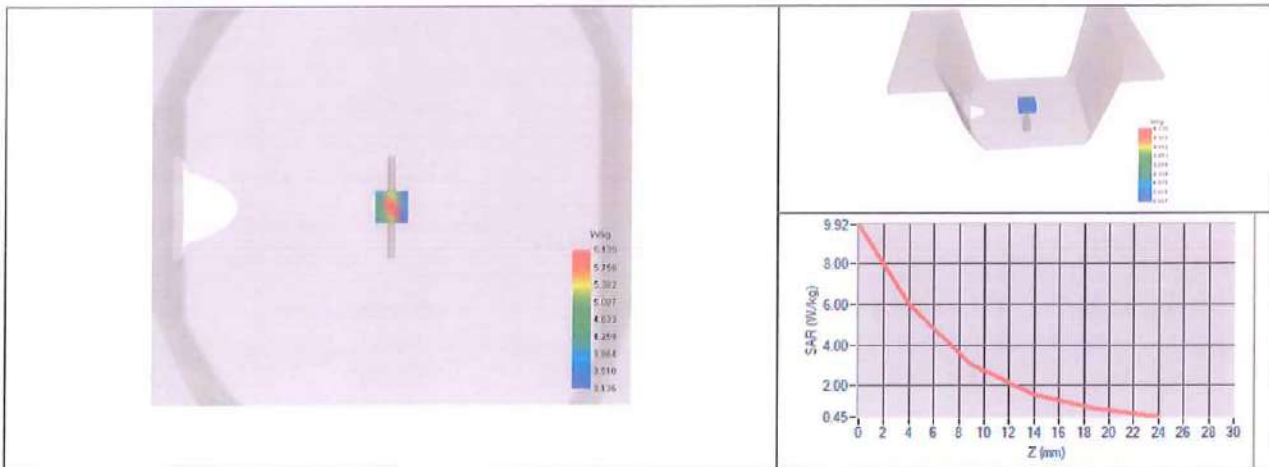



7 LIST OF EQUIPMENT

Equipment Summary Sheet				
Equipment Description	Manufacturer / Model	Identification No.	Current Calibration Date	Next Calibration Date
SAM Phantom	MVG	SN 13/09 SAM68	Validated. No cal required.	Validated. No cal required.
COMOSAR Test Bench	Version 3	NA	Validated. No cal required.	Validated. No cal required.
Network Analyzer	Rohde & Schwarz ZVM	100203	08/2021	08/2024
Network Analyzer – Calibration kit	Rohde & Schwarz ZV-Z235	101223	07/2022	07/2025
Calipers	Mitutoyo	SN 0009732	11/2022	11/2025
Reference Probe	MVG	3523-EPGO-429	11/2023	11/2024
Multimeter	Keithley 2000	4013982	02/2023	02/2026
Signal Generator	Rohde & Schwarz SMB	106589	03/2022	03/2025
Amplifier	MVG	MODU-023-C-0002	Characterized prior to test. No cal required.	Characterized prior to test. No cal required.
Power Meter	NI-USB 5680	170100013	06/2021	06/2024
Power Meter	Keysight U2000A	SN: MY62340002	10/2022	10/2025
Directional Coupler	Krytar 158020	131467	Characterized prior to test. No cal required.	Characterized prior to test. No cal required.
Temperature / Humidity Sensor	Testo 184 H1	44225320	06/2021	06/2024



COMOSAR E-Field Probe Calibration Report

Ref : ACR.250.20.23.BES.A

**WORLD STANDARDIZATION CERTIFICATION
& TESTING GROUP CO.,LTD**
**BLOCK A, BAO SHI SCIENCE PARK,BAO SHI ROAD,
BAO'AN DISTRICT**
SHENZHEN 518108,P.R. CHINA
MVG COMOSAR DOSIMETRIC E-FIELD PROBE
SERIAL NO.: 3323-EPGO-424

Calibrated at MVG
Z.I. de la pointe du diable
Technopôle Brest Iroise – 295 avenue Alexis de Rochon
29280 PLOUZANE - FRANCE

Calibration date: 09/07/2023





Accreditations #2-6789
Scope available on www.cofrac.fr

The use of the Cofrac brand and the accreditation references is prohibited from any reproduction.

Summary:

This document presents the method and results from an accredited COMOSAR Dosimetric E-Field Probe calibration performed at MVG, using the CALIPROBE test bench, for use with a MVG COMOSAR system only. The test results covered by accreditation are traceable to the International System of Units (SI).

	<i>Name</i>	<i>Function</i>	<i>Date</i>	<i>Signature</i>
<i>Prepared by :</i>	Pedro Ruiz	Measurement Responsible	9/7/2023	
<i>Checked & approved by:</i>	Jérôme Luc	Technical Manager	9/7/2023	
<i>Authorized by:</i>	Yann Toutain	Laboratory Director	9/11/2023	

	<i>Customer Name</i>
<i>Distribution :</i>	World Standardization Certification & Testing Group Co.,Ltd

<i>Issue</i>	<i>Name</i>	<i>Date</i>	<i>Modifications</i>
A	Pedro Ruiz	9/7/2023	Initial release



TABLE OF CONTENTS

1 Device Under Test4

2 Product Description4

 2.1 General Information4

3 Measurement Method4

 3.1 Sensitivity4

 3.2 Linearity5

 3.3 Isotropy5

 3.4 Boundary Effect5

4 Measurement Uncertainty6

5 Calibration Results.....6

 5.1 Calibration in air6

 5.2 Calibration in liquid7

6 Verification Results9

7 List of Equipment10

1 DEVICE UNDER TEST

Device Under Test	
Device Type	COMOSAR DOSIMETRIC E FIELD PROBE
Manufacturer	MVG
Model	SSE2
Serial Number	3323-EPGO-424
Product Condition (new / used)	New
Frequency Range of Probe	0.15 GHz-7.5GHz
Resistance of Three Dipoles at Connector	Dipole 1: R1=0.233 MΩ Dipole 2: R2=0.221 MΩ Dipole 3: R3=0.224 MΩ

2 PRODUCT DESCRIPTION

2.1 GENERAL INFORMATION

MVG's COMOSAR E field Probes are built in accordance to the IEC/IEEE 62209-1528 and FCC KDB865664 D01 standards.



Figure 1 – MVG COMOSAR Dosimetric E field Probe

Probe Length	330 mm
Length of Individual Dipoles	2 mm
Maximum external diameter	8 mm
Probe Tip External Diameter	2.5 mm
Distance between dipoles / probe extremity	1 mm

3 MEASUREMENT METHOD

The IEC/IEEE 62209-1528 and FCC KDB865664 D01 standards provide recommended practices for the probe calibrations, including the performance characteristics of interest and methods by which to assess their effect. All calibrations / measurements performed meet the fore-mentioned standards.

3.1 SENSITIVITY

The sensitivity factors of the three dipoles were determined using a two step calibration method (air and tissue simulating liquid) using waveguides as outlined in the standards for frequency range 600-7500MHz and using the calorimeter cell method (transfer method) as outlined in the standards for frequency 150-450 MHz.

3.2 LINEARITY

The evaluation of the linearity was done in free space using the waveguide, performing a power sweep to cover the SAR range 0.01W/kg to 100W/kg.

3.3 ISOTROPY

The axial isotropy was evaluated by exposing the probe to a reference wave from a standard dipole with the dipole mounted under the flat phantom in the test configuration suggested for system validations and checks. The probe was rotated along its main axis from 0 to 360 degrees in 15-degree steps. The hemispherical isotropy is determined by inserting the probe in a thin plastic box filled with tissue-equivalent liquid, with the plastic box illuminated with the fields from a half wave dipole. The dipole is rotated about its axis (0°–180°) in 15° increments. At each step the probe is rotated about its axis (0°–360°).

3.4 BOUNDARY EFFECT

The boundary effect is defined as the deviation between the SAR measured data and the expected exponential decay in the liquid when the probe is oriented normal to the interface. To evaluate this effect, the liquid filled flat phantom is exposed to fields from either a reference dipole or waveguide. With the probe normal to the phantom surface, the peak spatial average SAR is measured and compared to the analytical value at the surface.

The boundary effect uncertainty can be estimated according to the following uncertainty approximation formula based on linear and exponential extrapolations between the surface and $d_{be} + d_{step}$ along lines that are approximately normal to the surface:

$$SAR_{uncertainty} [\%] = \Delta SAR_{be} \frac{(d_{be} + d_{step})^2}{2d_{step}} \frac{(e^{-d_{be}/\delta})}{\delta/2} \quad \text{for } (d_{be} + d_{step}) < 10 \text{ mm}$$

where

- $SAR_{uncertainty}$ is the uncertainty in percent of the probe boundary effect
- d_{be} is the distance between the surface and the closest *zoom-scan* measurement point, in millimetre
- Δ_{step} is the separation distance between the first and second measurement points that are closest to the phantom surface, in millimetre, assuming the boundary effect at the second location is negligible
- δ is the minimum penetration depth in millimetres of the head tissue-equivalent liquids defined in this standard, i.e., $\delta \approx 14$ mm at 3 GHz;
- ΔSAR_{be} in percent of SAR is the deviation between the measured SAR value, at the distance d_{be} from the boundary, and the analytical SAR value.

The measured worst case boundary effect $SAR_{uncertainty}[\%]$ for scanning distances larger than 4mm is 1.0% Limit ,2%).

4 MEASUREMENT UNCERTAINTY

The guidelines outlined in the IEC/IEEE 62209-1528 and FCC KDB865664 D01 standards were followed to generate the measurement uncertainty associated with a SAR probe calibration using the waveguide or calorimetric cell technique depending on the frequency.

The estimated expanded uncertainty (k=2) in calibration for SAR (W/kg) is +/-11% for the frequency range 150-450MHz.

The estimated expanded uncertainty (k=2) in calibration for SAR (W/kg) is +/-14% for the frequency range 600-7500MHz.

5 CALIBRATION RESULTS

Ambient condition	
Liquid Temperature	20 +/- 1 °C
Lab Temperature	20 +/- 1 °C
Lab Humidity	30-70 %

5.1 CALIBRATION IN AIR

The following curve represents the measurement in waveguide of the voltage picked up by the probe toward the E-field generated inside the waveguide.

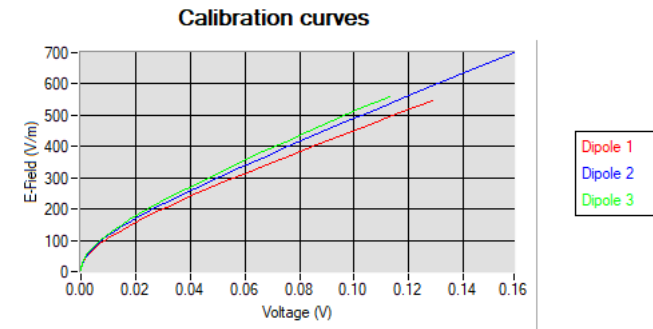

From this curve, the sensitivity in air is calculated using the below formula.

$$E^2 = \sum_{i=1}^3 \frac{V_i (1 + V_i / DCP_i)}{Norm_i}$$

where

Vi=voltage readings on the 3 channels of the probe

DCPi=diode compression point given below for the 3 channels of the probe

Normi=dipole sensitivity given below for the 3 channels of the probe

Normx dipole 1 ($\mu\text{V}/(\text{V}/\text{m})^2$)	Normy dipole 2 ($\mu\text{V}/(\text{V}/\text{m})^2$)	Normz dipole 3 ($\mu\text{V}/(\text{V}/\text{m})^2$)
0.94	0.82	0.75

DCP dipole 1 (mV)	DCP dipole 2 (mV)	DCP dipole 3 (mV)
109	103	104

5.2 CALIBRATION IN LIQUID

The calorimeter cell or the waveguide is used to determine the calibration in liquid using the formula below.

$$ConvF = \frac{E_{liquid}^2}{E_{air}^2}$$

The E-field in the liquid is determined from the SAR measurement according to the below formula.

$$E_{liquid}^2 = \frac{\rho SAR}{\sigma}$$

where

σ =the conductivity of the liquid

ρ =the volumetric density of the liquid

SAR=the SAR measured from the formula that depends on the setup used. The SAR formulas are given below

For the calorimeter cell (150-450 MHz), the formula is:

$$SAR = c \frac{dT}{dt}$$

where

c =the specific heat for the liquid

dT/dt =the temperature rises over the time

For the waveguide setup (600-75000 MHz), the formula is:

$$SAR = \frac{4P_w}{ab\delta} e^{-\frac{2z}{\delta}}$$

where

a =the larger cross-sectional of the waveguide

b =the smaller cross-sectional of the waveguide

δ =the skin depth for the liquid in the waveguide

P_w =the power delivered to the liquid

The below table summarize the ConvF for the calibrated liquid. The curves give examples for the measured SAR depending on the voltage in some liquid.

Liquid	Frequency (MHz*)	ConvF
HL750	750	1.62
BL750	750	1.48
HL850	835	1.56
BL850	835	1.47
HL900	900	1.53
BL900	900	1.50
HL1800	1800	1.79
BL1800	1800	1.73
HL1900	1900	2.02
BL1900	1900	1.86
HL2000	2000	2.06
BL2000	2000	1.89
HL2450	2450	2.11
BL2450	2450	2.17
HL2600	2600	2.02
BL2600	2600	2.17
HL3300	3300	1.76
BL3300	3300	1.91
HL3900	3900	2.35
BL3900	3900	1.98
HL4200	4200	2.15
BL4200	4200	2.12
HL4600	4600	2.12
BL4600	4600	2.25
HL4900	4900	2.00
BL4900	4900	2.01
HL5200	5200	2.19
BL5200	5200	2.17
HL5400	5400	2.31
BL5400	5400	2.09
HL5600	5600	2.27
BL5600	5600	2.01
HL5800	5800	2.26
BL5800	5800	2.16

(*) Frequency validity is +/-50MHz below 600MHz, +/-100MHz from 600MHz to 6GHz and +/-700MHz above 6GHz

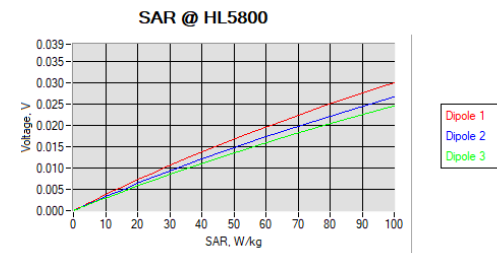
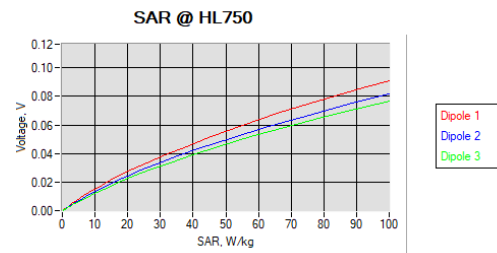

6 VERIFICATION RESULTS

The figures below represent the measured linearity and axial isotropy for this probe. The probe specification is +/-0.2 dB for linearity and +/-0.15 dB for axial isotropy.

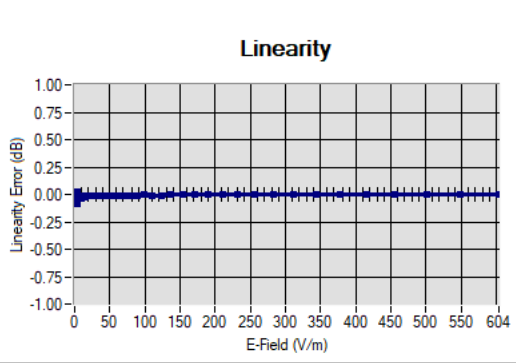

Linearity: +/-1.94% (+/-0.09dB)

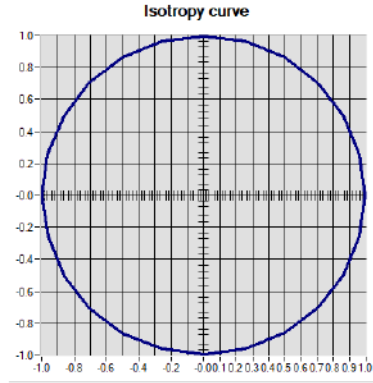

Isotropy +/-0.37% (+/-0.02dB)

7 LIST OF EQUIPMENT

Equipment Summary Sheet				
Equipment Description	Manufacturer / Model	Identification No.	Current Calibration Date	Next Calibration Date
CALIPROBE Test Bench	Version 2	NA	Validated. No cal required.	Validated. No cal required.
Network Analyzer	Rohde & Schwarz ZVM	100203	08/2021	08/2024
Network Analyzer	Agilent 8753ES	MY40003210	10/2019	10/2023
Network Analyzer – Calibration kit	HP 85033D	3423A08186	06/2021	06/2027
Network Analyzer – Calibration kit	Rohde & Schwarz ZV-Z235	101223	07/2022	07/2025
Multimeter	Keithley 2000	4013982	02/2023	02/2026
Signal Generator	Rohde & Schwarz SMB	106589	03/2022	03/2025
Amplifier	MVG	MODU-023-C-0002	Characterized prior to test. No cal required.	Characterized prior to test. No cal required.
Power Meter	NI-USB 5680	170100013	06/2021	06/2024
Power Meter	Keysight U2000A	SN: MY62340002	10/2022	10/2025
Directional Coupler	Krytar 158020	131467	Characterized prior to test. No cal required.	Characterized prior to test. No cal required.
Fluoroptic Thermometer	LumaSense Luxtron 812	94264	09/2022	09/2025
Coaxial cell	MVG	SN 32/16 COAXCELL_1	Validated. No cal required.	Validated. No cal required.
Waveguide	MVG	SN 32/16 WG2_1	Validated. No cal required.	Validated. No cal required.
Liquid transition	MVG	SN 32/16 WGLIQ_0G600_1	Validated. No cal required.	Validated. No cal required.
Waveguide	MVG	SN 32/16 WG4_1	Validated. No cal required.	Validated. No cal required.
Liquid transition	MVG	SN 32/16 WGLIQ_0G900_1	Validated. No cal required.	Validated. No cal required.
Waveguide	MVG	SN 32/16 WG6_1	Validated. No cal required.	Validated. No cal required.
Liquid transition	MVG	SN 32/16 WGLIQ_1G500_1	Validated. No cal required.	Validated. No cal required.
Waveguide	MVG	SN 32/16 WG8_1	Validated. No cal required.	Validated. No cal required.



Liquid transition	MVG	SN 32/16 WGLIQ_1G800B_1	Validated. No cal required.	Validated. No cal required.
Liquid transition	MVG	SN 32/16 WGLIQ_1G800H_1	Validated. No cal required.	Validated. No cal required.
Waveguide	MVG	SN 32/16 WG10_1	Validated. No cal required.	Validated. No cal required.
Liquid transition	MVG	SN 32/16 WGLIQ_3G500_1	Validated. No cal required.	Validated. No cal required.
Waveguide	MVG	SN 32/16 WG12_1	Validated. No cal required.	Validated. No cal required.
Liquid transition	MVG	SN 32/16 WGLIQ_5G000_1	Validated. No cal required.	Validated. No cal required.
Waveguide	MVG	SN 32/16 WG14_1	Validated. No cal required.	Validated. No cal required.
Liquid transition	MVG	SN 32/16 WGLIQ_7G000_1	Validated. No cal required.	Validated. No cal required.
Temperature / Humidity Sensor	Testo 184 H1	44225320	06/2021	06/2024



Dielectric Probe Calibration Report

Ref : ACR317.11.23.BES.A

WORLD STANDARDIZATION CERTIFICATION & TESTING GROUP CO.,LTD

BLOCK A, BAO SHI SCIENCE PARK, BAO SHI ROAD,
BAO'AN DISTRICT

SHENZHEN 518108, P.R. CHINA

MVG LIMESAR DIELECTRIC PROBE

FREQUENCY: 0.15-7.5 GHZ

SERIAL NO.: 0923-OCPG-091

Calibrated at MVG

Z.I. de la pointe du diable

Technopôle Brest Iroise – 295 avenue Alexis de Rochon

29280 PLOUZANE - FRANCE

Calibration date: 10/31/2023



Accreditations #2-6789
Scope available on www.cofrac.fr

The use of the Cofrac brand and the accreditation references is prohibited from any reproduction.

Summary:

This document presents the method and results from an accredited Dielectric Probe calibration performed at MVG, using the LIMESAR test bench. The test results covered by accreditation are traceable to the International System of Units (SI).



	<i>Name</i>	<i>Function</i>	<i>Date</i>	<i>Signature</i>
<i>Prepared by :</i>	Cyrille ONNEE	Measurement Responsible	11/13/2023	
<i>Checked & approved by:</i>	Jérôme Luc	Technical Manager	11/13/2023	
<i>Authorized by:</i>	Yann Toutain	Laboratory Director	11/13/2023	

Yann
Toutain ID

Signature
numérique de Yann
Toutain ID
Date: 2023.11.13
15:50:42 +01'00'

	<i>Customer Name</i>
<i>Distribution :</i>	World Standardization Certification & Testing Group Co ,Ltd

<i>Issue</i>	<i>Name</i>	<i>Date</i>	<i>Modifications</i>
A	Cyrille ONNEE	11/13/2023	Initial release



TABLE OF CONTENTS

1 Introduction..... 4

2 Device Under Test 4

3 Product Description 4

 3.1 General Information 4

4 Measurement Method 5

 4.1 Liquid complex Permittivity Measurements 5

5 Measurement Uncertainty..... 5

6 Calibration Results..... 5

 6.1 Liquid complex Permittivity Measurement 5

7 List of Equipment 7

1 INTRODUCTION

This document contains a summary of the suggested methods and requirements set forth by the IEC/IEEE 62209-1528 and FCC KDB865664 D01 standards for liquid permittivity measurements and the measurements that were performed to verify that the product complies with the fore mentioned standards.

2 DEVICE UNDER TEST

Device Under Test	
Device Type	LIMESAR DIELECTRIC PROBE
Manufacturer	MVG
Model	SCLMP
Serial Number	0923-OCPG-091
Product Condition (new / used)	New

3 PRODUCT DESCRIPTION

3.1 GENERAL INFORMATION

MVG's Dielectric Probes are built in accordance to the IEC/IEEE 62209-1528 and FCC KDB865664 D01 standards. The product is designed for use with the LIMESAR test bench only.

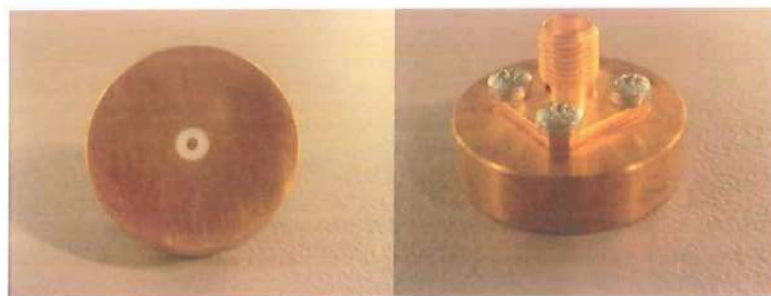

Figure 1 – MVG LIMESAR Dielectric Probe



4 MEASUREMENT METHOD

The IEC/IEEE 62209-1528 and FCC KDB865664 D01 standards outline techniques for dielectric property measurements. The LIMESAR test bench employs one of the methods outlined in the standards, using a contact probe or open-ended coaxial transmission-line probe and vector network analyzer. The standards recommend the measurement of two reference materials that have well established and stable dielectric properties to validate the system, one for the calibration and one for checking the calibration. The LIMESAR test bench uses De-ionized water as the reference for the calibration and either Ethenediol or Methanol as the reference for checking the calibration. The following measurements were performed to verify that the product complies with the fore-mentioned standards.

4.1 LIQUID COMPLEX PERMITTIVITY MEASUREMENTS

The complex permittivity of a liquid with known dielectric properties was measured and the measurement results compared to the values provided in the fore mentioned standards.

5 MEASUREMENT UNCERTAINTY

The guidelines outlined in the IEC/IEEE 62209-1528 and FCC KDB865664 D01 standards were followed to generate the measurement uncertainty associated with a SAR probe calibration using the waveguide or calorimetric cell technique depending on the frequency.

The estimated expanded uncertainty (k=2) in calibration for relative permittivity is +/-10% with respect to measurement conditions.

The estimated expanded uncertainty (k=2) in calibration for conductivity (S/m) is +/-8.2% with respect to measurement conditions.

6 CALIBRATION RESULTS

Measurement Condition

Software	LIMESAR
Liquid Temperature	20 +/- 1 °C
Lab Temperature	20 +/- 1 °C
Lab Humidity	30-70 %

6.1 LIQUID COMPLEX PERMITTIVITY MEASUREMENT

A liquid of known characteristics (methanol or ethenediol) is measured with the probe and the results (complex permittivity $\epsilon' + j\epsilon''$) are compared with the reference values for this liquid.

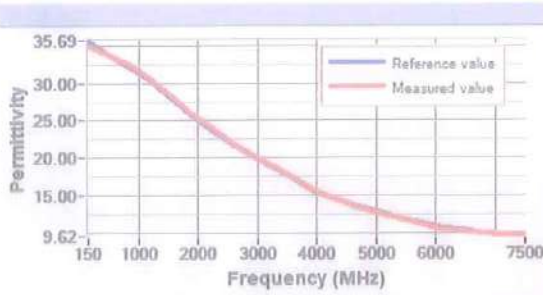

Frequency (MHz)	Methanol Permittivity (Reference)	Methanol Permittivity (Measure)	Difference (%)	Limit (+/- %)
150	35.69	35.02	1.9	10.0
500	33.64	33.69	-0.1	10.0
850	32.06	32.42	-1.1	10.0
1200	30.29	30.53	-0.8	10.0
1550	27.91	28.32	-1.5	10.0
1900	25.60	25.82	-0.8	10.0
2250	23.69	23.93	-1.0	10.0
2600	21.74	21.86	-0.6	10.0
2950	20.09	20.25	-0.8	10.0
3300	18.67	18.71	-0.2	10.0
3650	16.99	17.11	-0.7	10.0
4000	15.46	15.46	-0.0	10.0
4350	14.50	14.41	0.6	10.0
4700	13.61	13.47	1.1	10.0
5050	12.83	12.63	1.6	10.0
5400	12.04	11.88	1.3	10.0
5750	11.33	11.15	1.6	10.0
6100	10.77	10.60	1.5	10.0
6450	10.43	10.26	1.6	10.0
6800	10.04	9.94	1.0	10.0
7150	9.73	9.79	-0.7	10.0
7500	9.62	9.81	-2.0	10.0

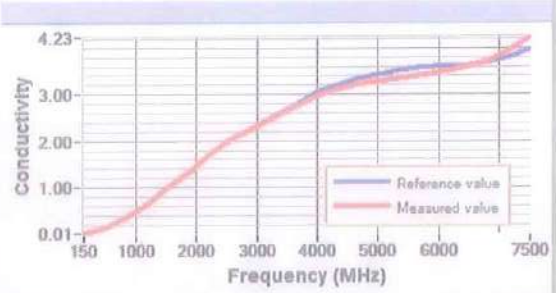

Frequency (MHz)	Methanol Conductivity (Reference)	Methanol Conductivity (Measure)	Difference (%)	Limit (+/- %)
150	0.01	0.01	-1.5	8.2
500	0.14	0.13	5.2	8.2
850	0.37	0.37	0.3	8.2
1200	0.65	0.66	-1.0	8.2
1550	1.03	1.04	-0.9	8.2
1900	1.36	1.36	0.2	8.2
2250	1.73	1.72	0.3	8.2
2600	2.04	2.04	0.3	8.2
2950	2.28	2.28	-0.3	8.2
3300	2.53	2.51	0.9	8.2
3650	2.77	2.74	0.9	8.2
4000	3.06	2.98	2.6	8.2
4350	3.22	3.12	3.2	8.2
4700	3.34	3.25	2.9	8.2
5050	3.44	3.30	4.0	8.2
5400	3.52	3.37	4.5	8.2
5750	3.58	3.40	4.9	8.2
6100	3.61	3.49	3.4	8.2
6450	3.63	3.59	1.1	8.2
6800	3.70	3.70	-0.1	8.2
7150	3.80	3.93	-3.3	8.2
7500	3.97	4.23	-6.4	8.2



7 LIST OF EQUIPMENT

Equipment Summary Sheet				
Equipment Description	Manufacturer / Model	Identification No.	Current Calibration Date	Next Calibration Date
LIMESAR Test Bench	Version 3	NA	Validated. No cal required.	Validated. No cal required.
Liquid measurement probe	MVG	SN 35/10 OCPG37	11/2022	11/2023
Network Analyzer	Rohde & Schwarz ZVM	100203	08/2021	08/2024
Network Analyzer – Calibration kit	Rohde & Schwarz ZV-Z235	101223	07/2022	07/2025
Temperature / Humidity Sensor	Testo 184 H1	44225320	06/2021	06/2024

