

| REVISION RECORD |         |           |       |
|-----------------|---------|-----------|-------|
| LTR             | ECO NO: | APPROVED: | DATE: |
|                 |         |           |       |
|                 |         |           |       |
|                 |         |           |       |

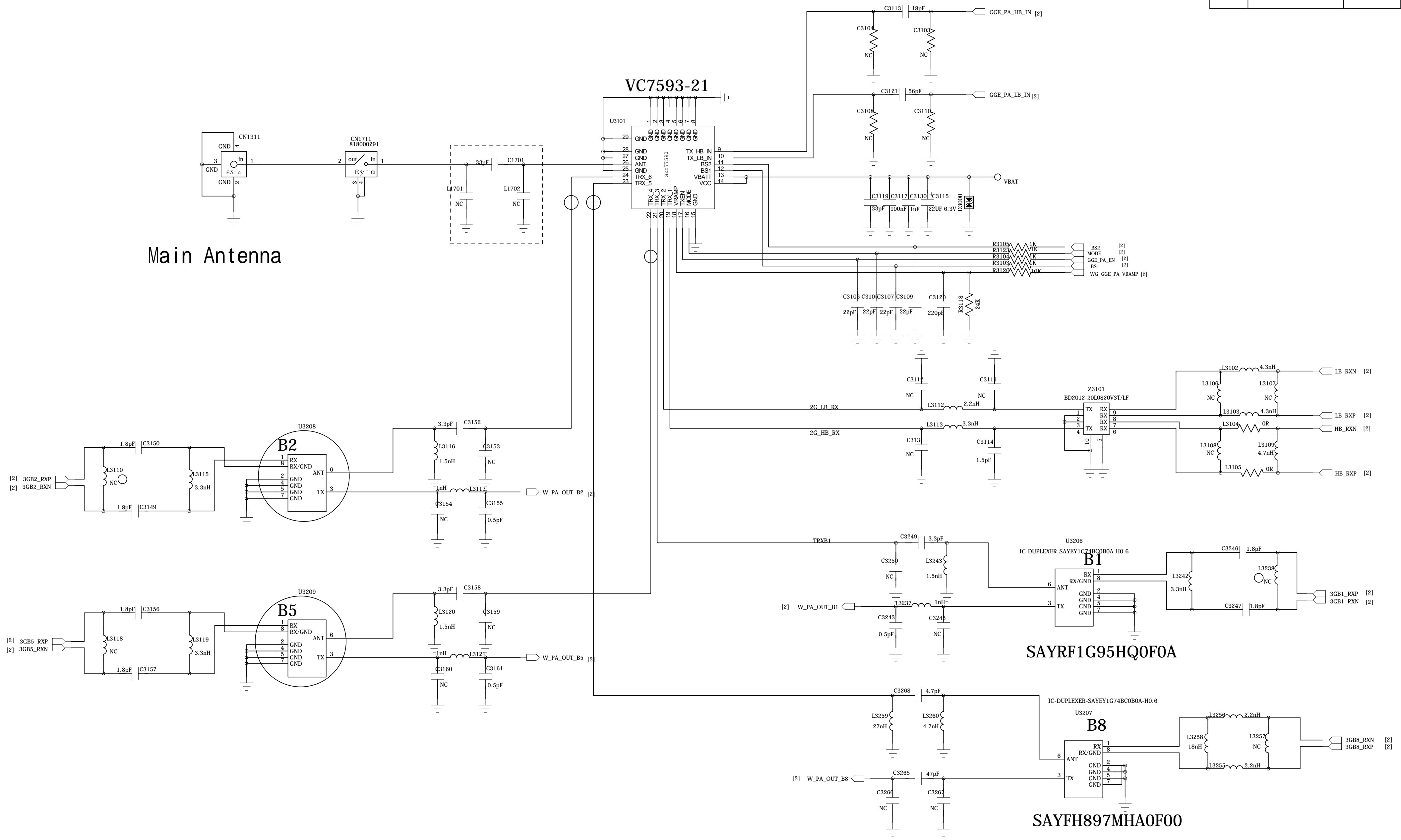

Main Antenna

|          |     |       |     |                      |  |               |  |                          |  |
|----------|-----|-------|-----|----------------------|--|---------------|--|--------------------------|--|
| COMPANY: |     |       |     | TRANSSION TOP SECRET |  | MODEL: H8022  |  | Modified Date: 2018/1/12 |  |
| DRAWN    | YQY | DATED | < > | TITLE: 1_RF_TXM_2G   |  | VERSION: V1.0 |  | SHEET: 1 OF 15           |  |
| CHECKED  | < > | DATED | < > |                      |  |               |  |                          |  |

| REVISION RECORD |         |           |       |
|-----------------|---------|-----------|-------|
| LTR             | ECO NO: | APPROVED: | DATE: |
|                 |         |           |       |
|                 |         |           |       |
|                 |         |           |       |

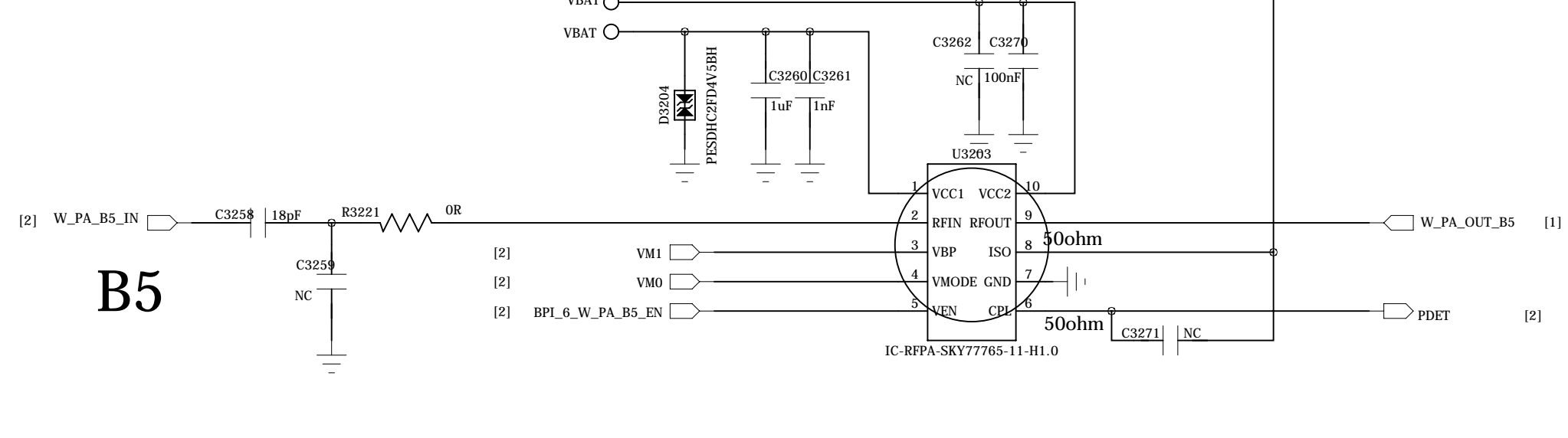
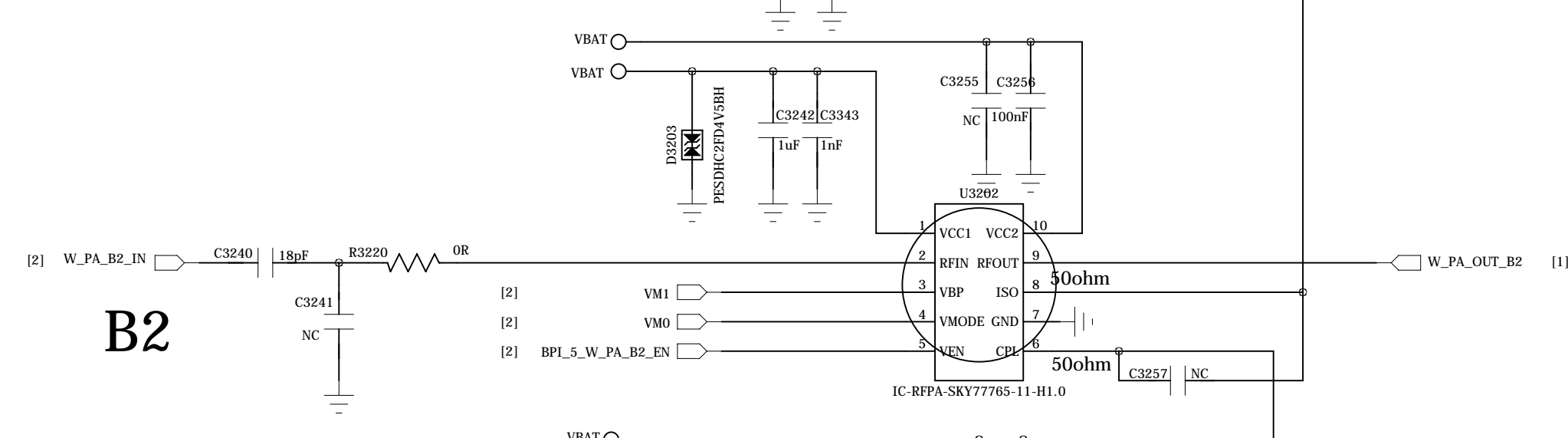
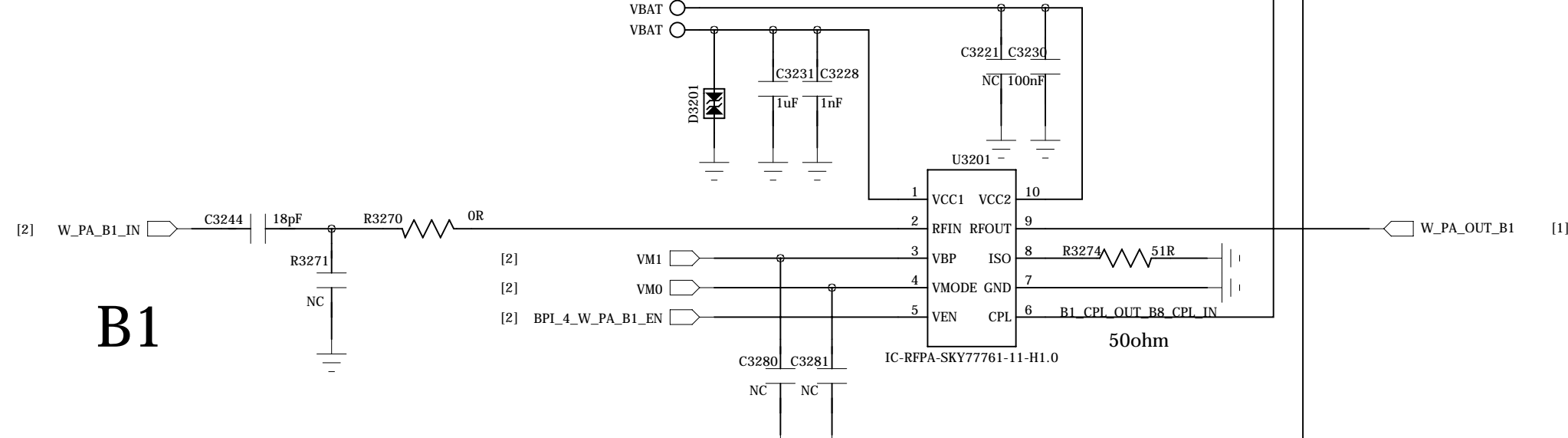
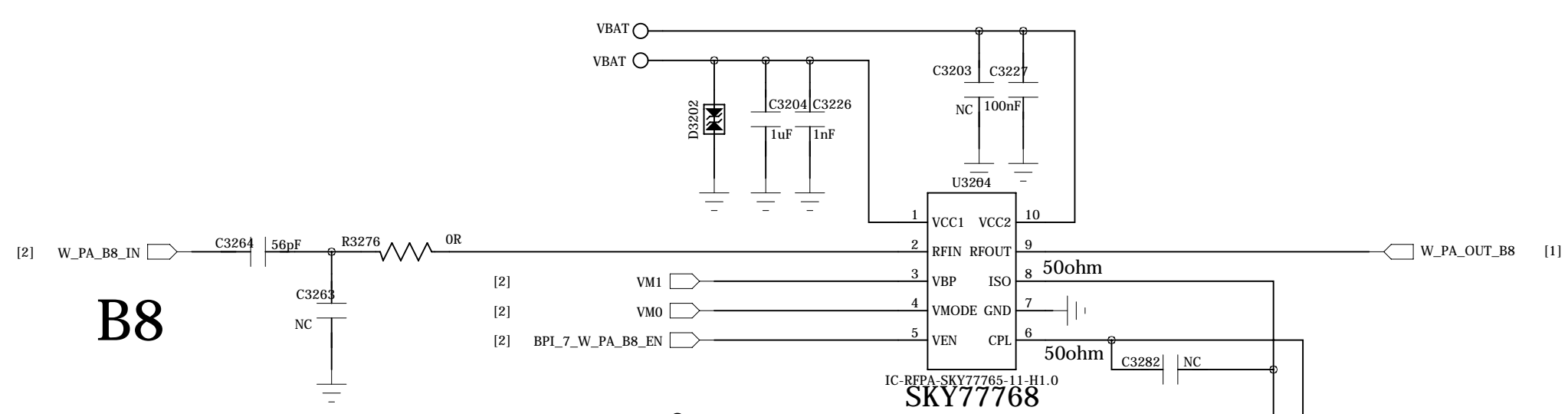

| MODE                    | Logic | DCXO_32K_EN | XMODE      | VXODIG     |
|-------------------------|-------|-------------|------------|------------|
| VCTCXO                  |       | 0(GND)      | 0(GND)     | 1(VIO18)   |
| DCXO + 32K XO           |       | 0(GND)      | 1(VIO18)   | 1(VIO18)   |
| default DCXO + 32K-Less |       | 1(VTXCO28)  | 1(VTXCO28) | 1(VTXCO28) |

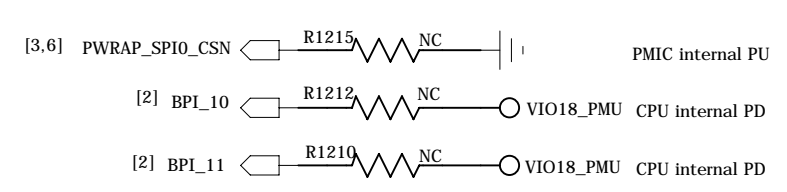
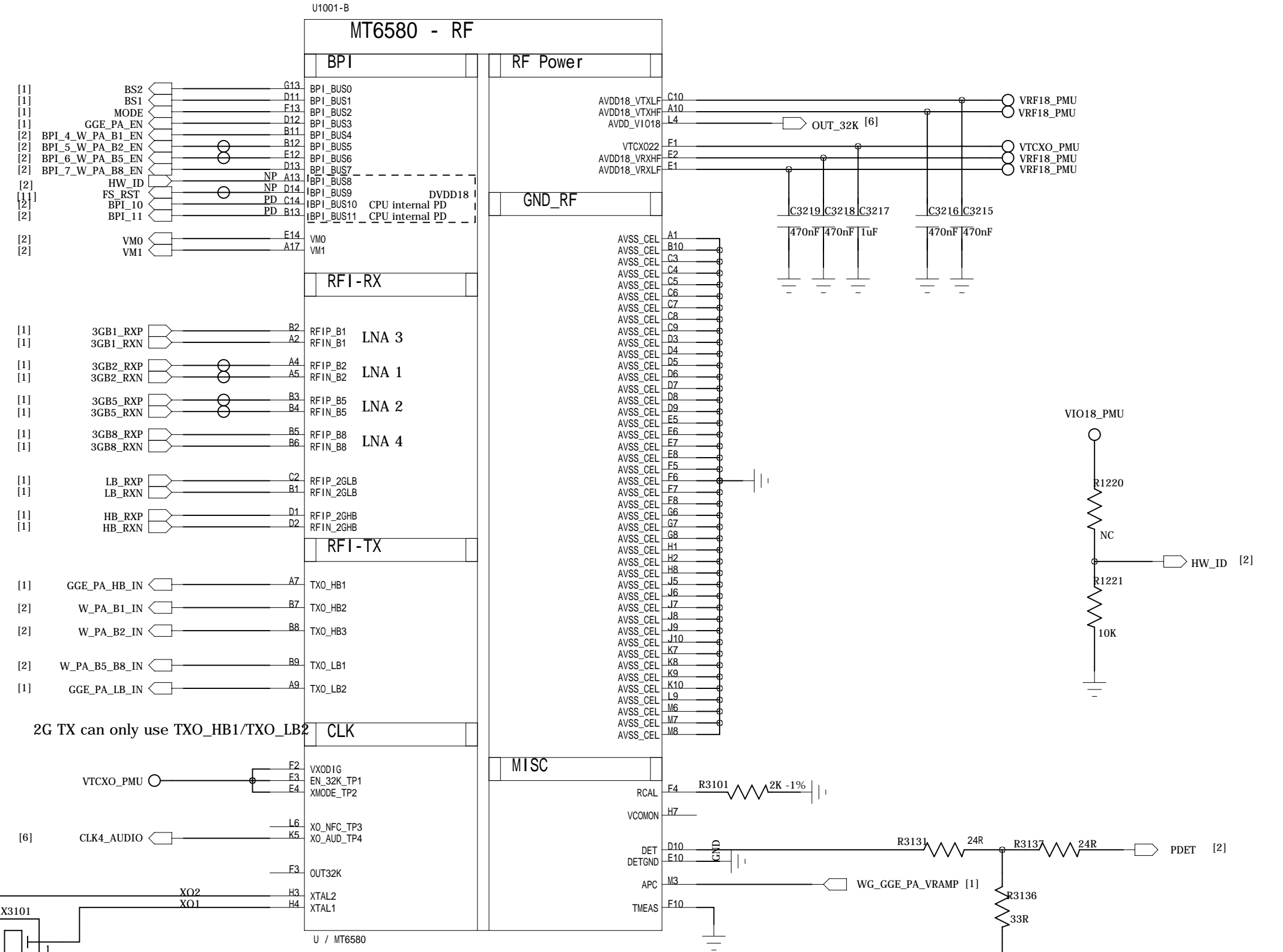
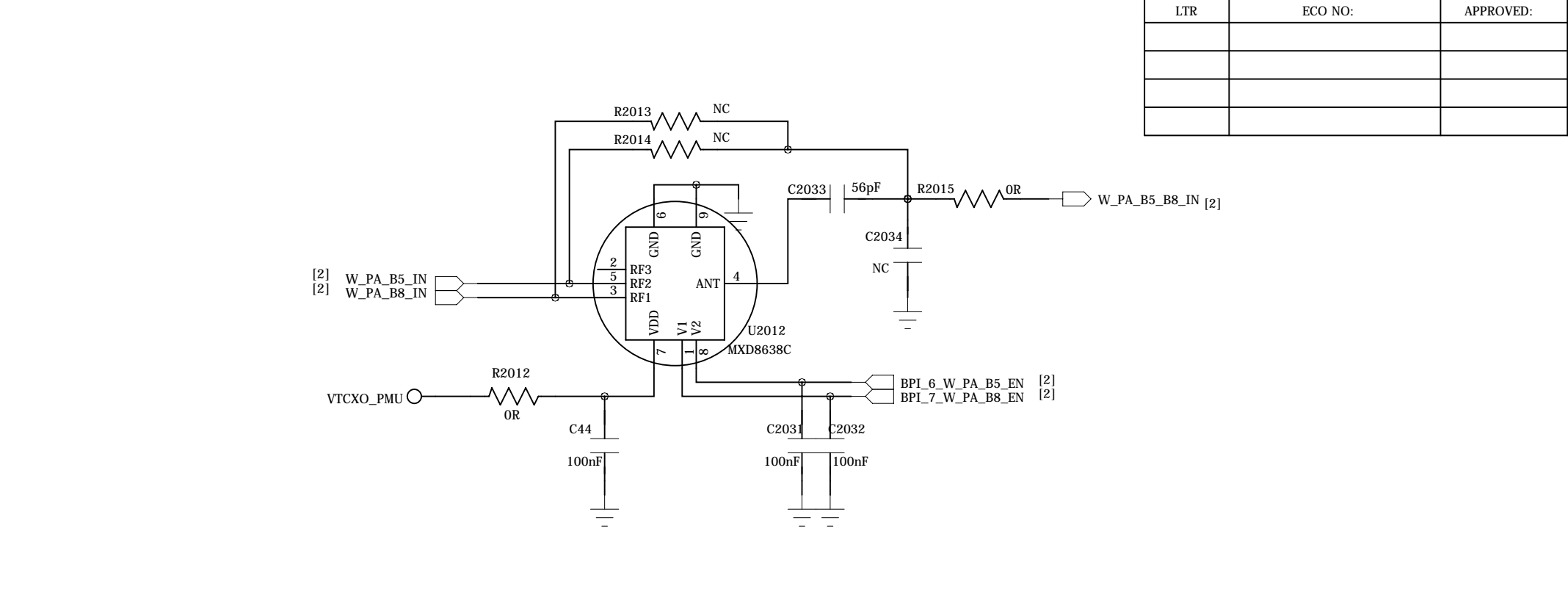
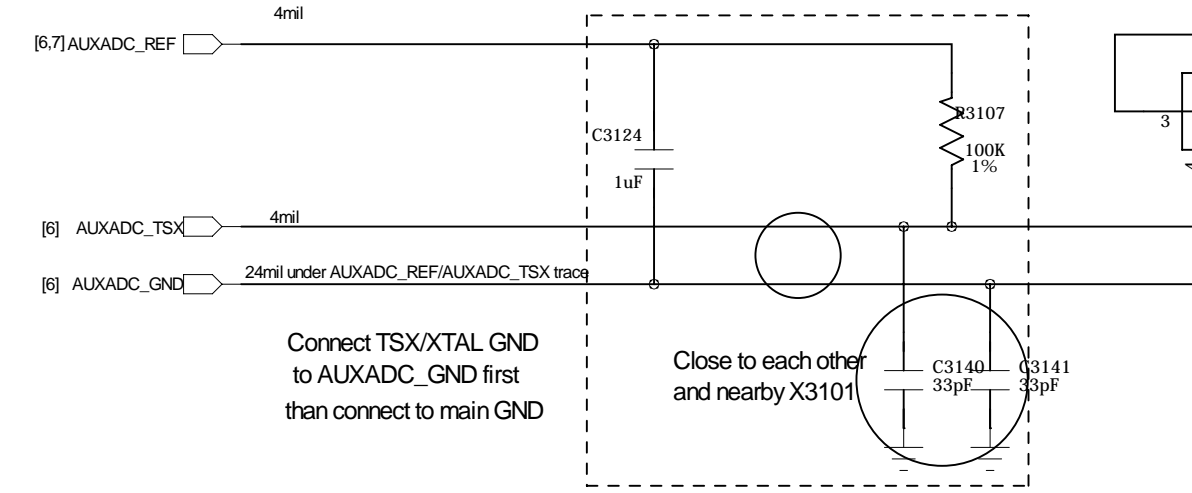

COMPANY: TRANSSION TOP SECRET

MODEL: H8022

Modified Date: 2018/1/12

VERSION: V1.0 SHEET: 2 OF 15

DCXO (0, x, x) : eMMC  
 (1, 0, 1) : LPDDR2 SLC Nand  
 (1, 0, 0) : LPDDR2 MLC Nand  
 (1, 1, 0) : Legacy Nand  
 (1, 1, 1) : Toggle/ONFI/TLC Nand

|         |     |       |     |
|---------|-----|-------|-----|
| DRAWN   | YQY | DATED | < > |
| CHECKED | < > | DATED | < > |

b= 4250

| REVISION RECORD |         |           |       |
|-----------------|---------|-----------|-------|
| LTR             | ECO NO: | APPROVED: | DATE: |
|                 |         |           |       |
|                 |         |           |       |
|                 |         |           |       |

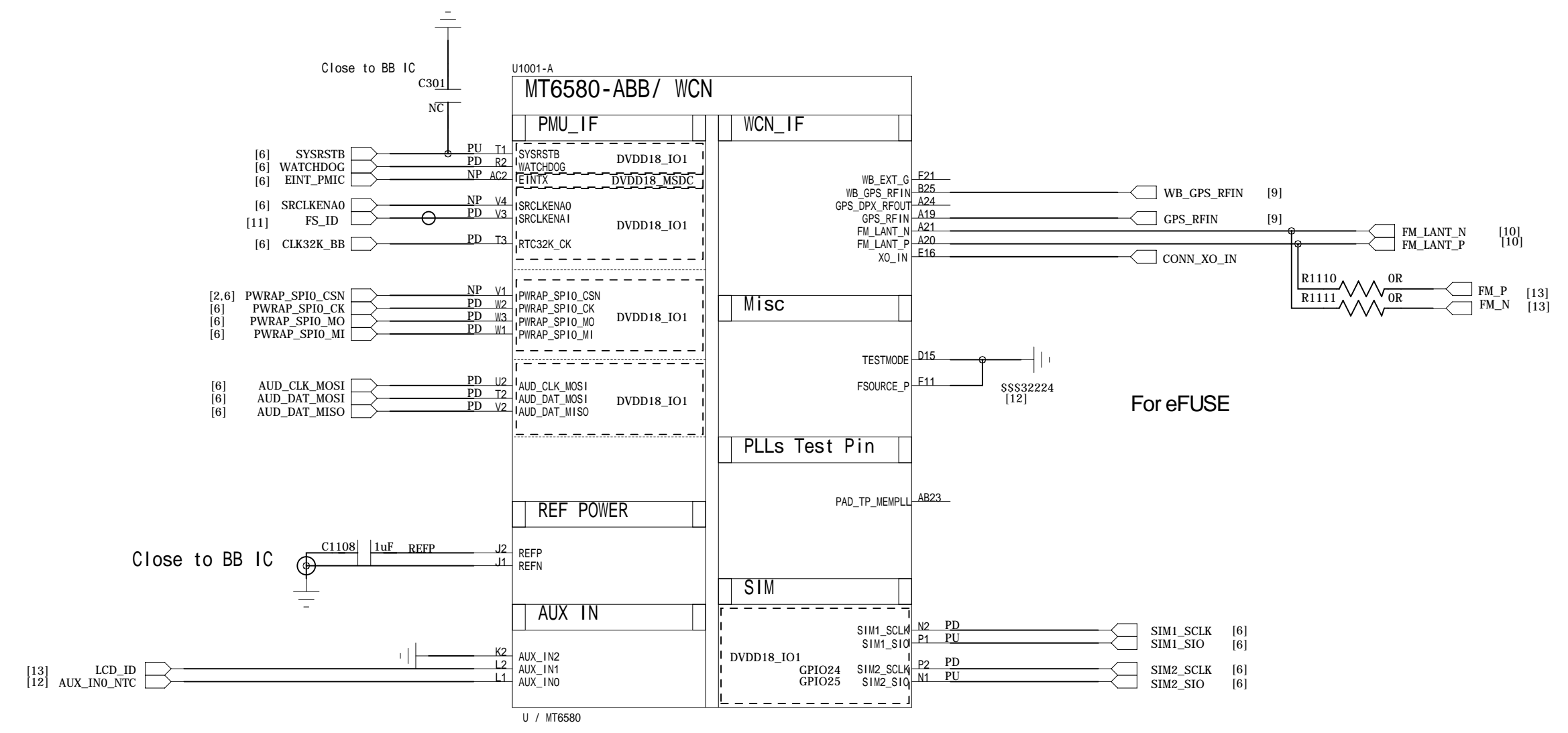

CONNSYS TCXO

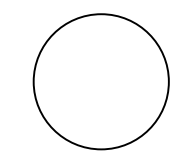

For eFUSE

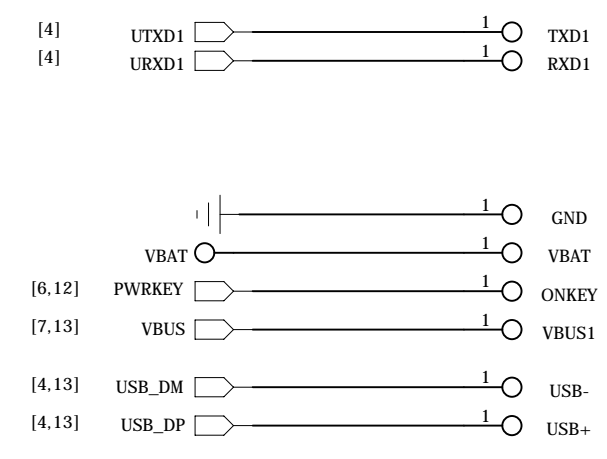

≈ úĭ ßĭ ÂÔØ° Í ≈ âÊÔ

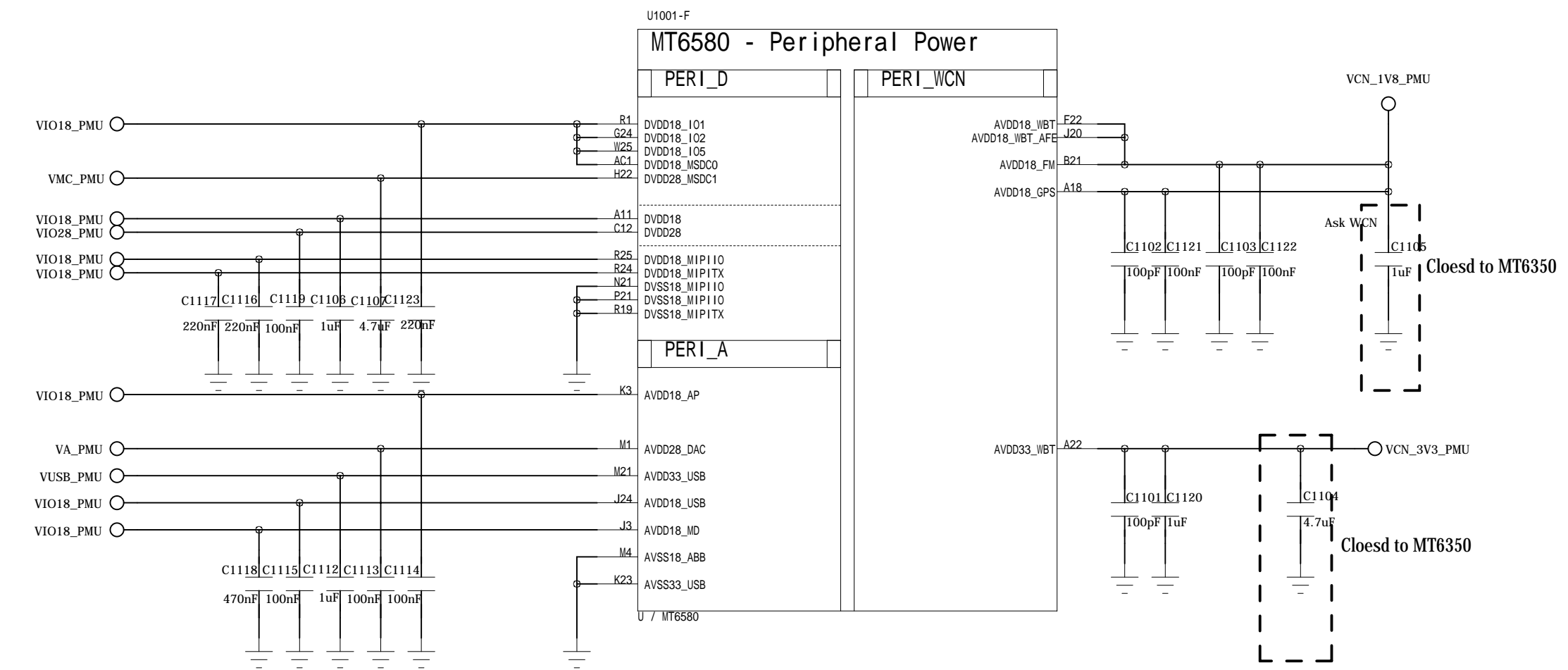

|             |  |           |  |                      |  |               |  |                          |  |
|-------------|--|-----------|--|----------------------|--|---------------|--|--------------------------|--|
| COMPANY:    |  |           |  | TRANSSION TOP SECRET |  | MODEL: H8022  |  | Modified Date: 2018/1/12 |  |
| DRAWN YQY   |  | DATED < > |  | TITLE: 3_BB_1_TP     |  | VERSION: V1.0 |  | SHEET: 3 OF 15           |  |
| CHECKED < > |  | DATED < > |  |                      |  |               |  |                          |  |

| REVISION RECORD |         |           |       |
|-----------------|---------|-----------|-------|
| LTR             | ECO NO: | APPROVED: | DATE: |
|                 |         |           |       |
|                 |         |           |       |
|                 |         |           |       |

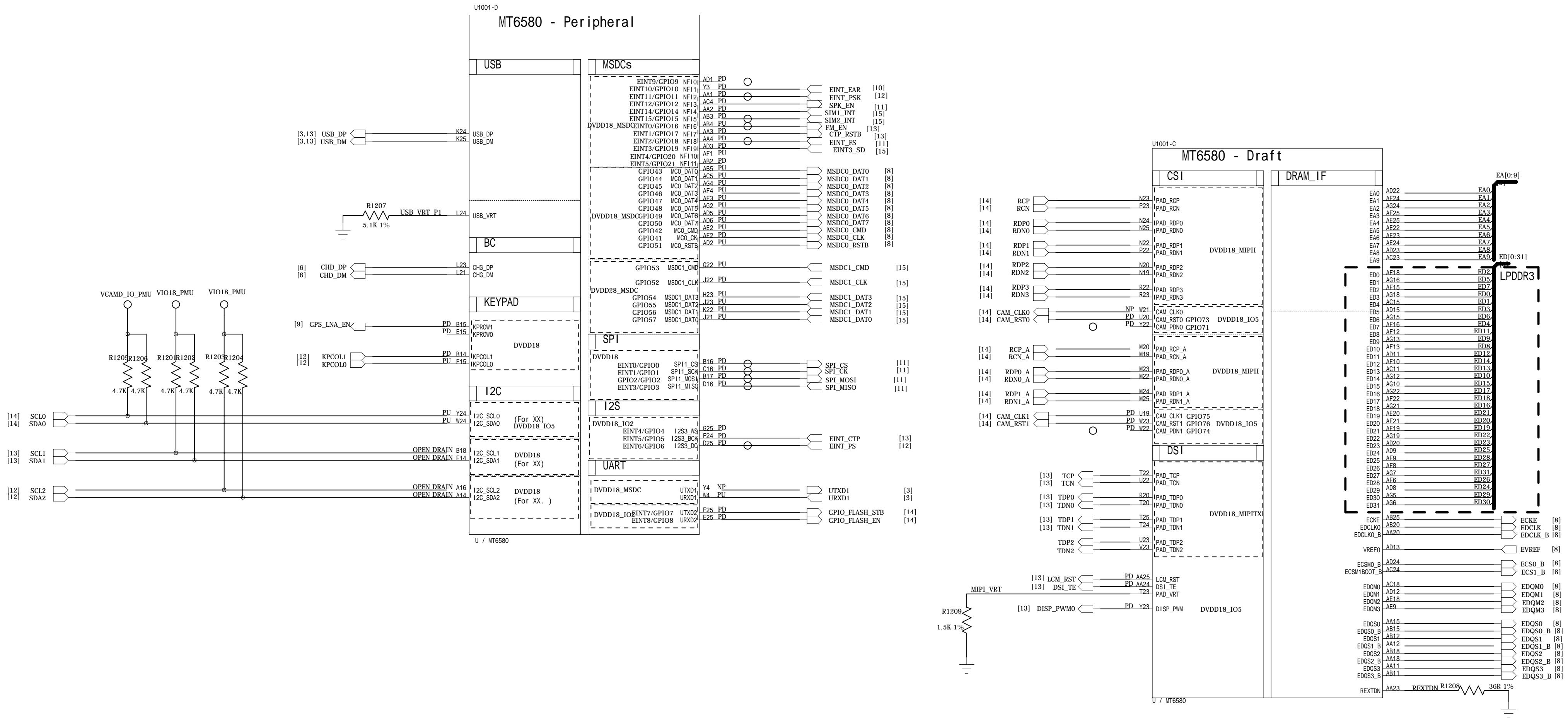

|          |     |       |     |                      |  |               |  |                          |  |
|----------|-----|-------|-----|----------------------|--|---------------|--|--------------------------|--|
| COMPANY: |     |       |     | TRANSSION TOP SECRET |  | MODEL: H8022  |  | Modified Date: 2018/1/12 |  |
| DRAWN    | YQY | DATED | < > | TITLE: 4_BB_2        |  | VERSION: V1.0 |  | SHEET: 4 OF 15           |  |
| CHECKED  | < > | DATED | < > |                      |  |               |  |                          |  |

| REVISION RECORD |         |           |       |
|-----------------|---------|-----------|-------|
| LTR             | ECO NO: | APPROVED: | DATE: |
|                 |         |           |       |
|                 |         |           |       |
|                 |         |           |       |

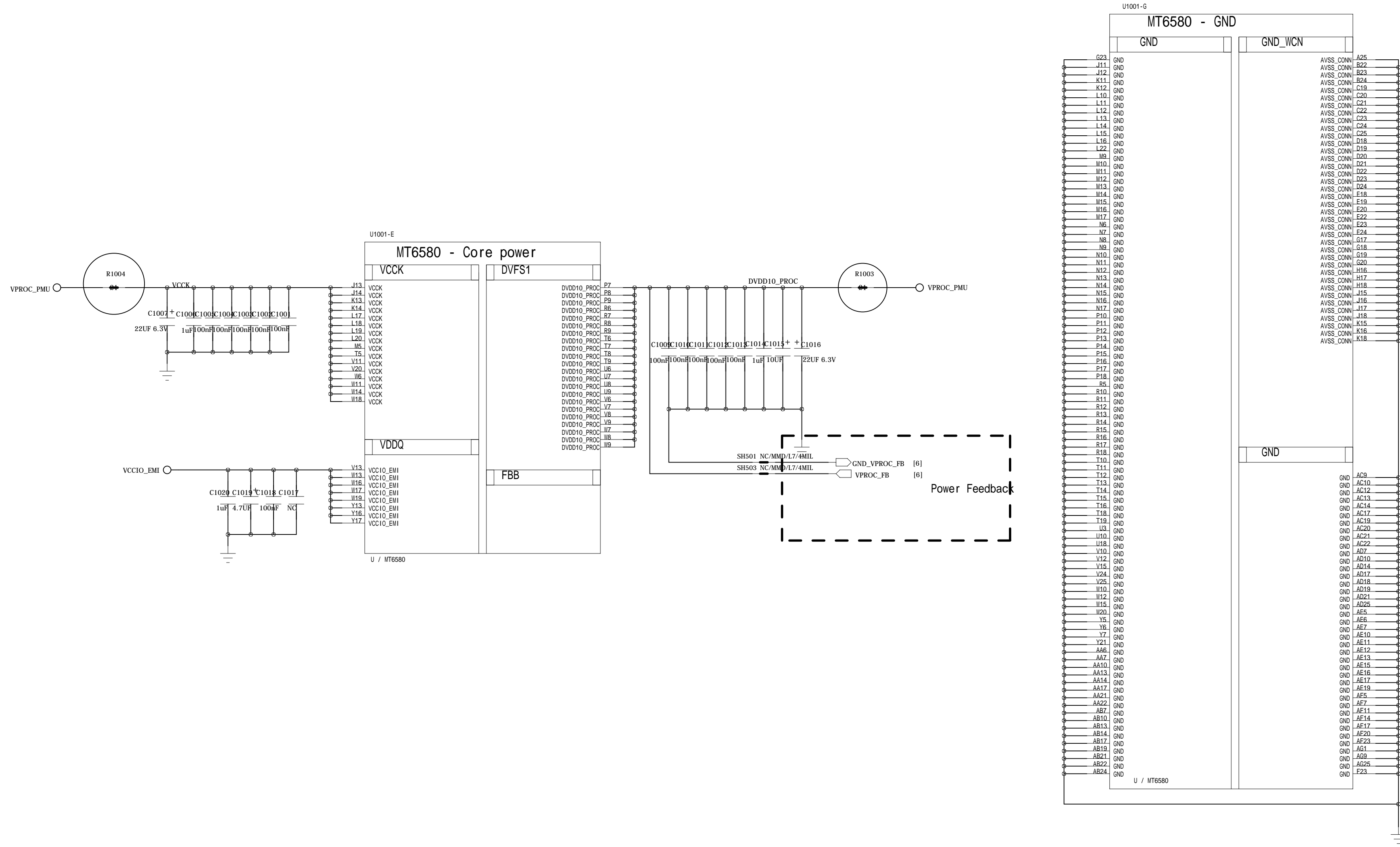

|             |  |           |  |                      |  |               |  |                          |  |
|-------------|--|-----------|--|----------------------|--|---------------|--|--------------------------|--|
| COMPANY:    |  |           |  | TRANSSION TOP SECRET |  | MODEL: H8022  |  | Modified Date: 2018/1/12 |  |
| DRAWN YQY   |  | DATED < > |  | TITLE: 5_BB_3        |  | VERSION: V1.0 |  | SHEET: 5 OF 15           |  |
| CHECKED < > |  | DATED < > |  |                      |  |               |  |                          |  |

| REVISION RECORD |         |           |       |
|-----------------|---------|-----------|-------|
| LTR             | ECO NO: | APPROVED: | DATE: |
|                 |         |           |       |
|                 |         |           |       |
|                 |         |           |       |

| PowerType              | Power    | Available Vout                             | Max current             |
|------------------------|----------|--|-------------------------|
| High Current Regulator | VCORE    | 0.7V-1.4V                                  | 2800ma                  |
|                        | VPROC    |  |                         |
|                        | VSRAM    |  |                         |
|                        | VSYS     |  |                         |
| Analog LDO             | VPA      | 0.5V-3.4V                                  | 600ma                   |
|                        | VA       | 2.8V                                       | 150ma                   |
|                        | VTCXO    | 2.2V                                       | 20ma                    |
|                        | VCAMA    | 2.8V                                       | 150ma                   |
| Digital LDO            | VCN28    | 2.8V                                       | 30ma                    |
|                        | VIO28    | 2.8V                                       | 200ma                   |
|                        | VUSB     | 3.3V                                       | 20ma                    |
|                        | VMC      | 1.8V/3.3V                                  | 100ma                   |
|                        | VMCH     | 3.0V/3.3V                                  | 400ma                   |
|                        | VEMC_3V3 | 3.0V/3.3V                                  | 400ma                   |
|                        | VIBR     | 1.2V/1.3V/1.5V/1.8V<br>2.0V/2.8V/3.0V/3.3V | 100ma                   |
|                        | VM       | 1.24V/1.39V/1.54V/1.84V                    | 700ma/600ma/600ma/300ma |
|                        | VRF18    | 1.825V                                     | 200ma                   |
|                        | VIO18    | 1.8V                                       | 300ma                   |
|                        | VCAMD    | 1.2V/1.3V/1.5V/1.8V                        | 150ma                   |
|                        | VCAM_IO  | 1.8V                                       | 100ma                   |
|                        | VCAM_AF  | 1.2V/1.3V/1.5V/1.8V<br>2.0V/2.8V/3.0V/3.3V | 100ma                   |
|                        | VGP1     | 1.2V/1.3V/1.5V/1.8V<br>2.0V/2.8V/3.0V/3.3V | 100ma                   |
|                        | VGP2     | 1.2V/1.3V/1.5V/1.8V<br>2.0V/2.5V/2.8V/3.0V | 100ma                   |
|                        | VGP3     | 1.2V/1.3V/1.5V/1.8V                        | 200ma                   |
|                        | VCN18    | 1.8V                                       | 120ma                   |
|                        | VCN33    | 3.3V/3.4V/3.5V/3.6V                        | 350ma                   |
|                        | VSIM1    | 1.8V/3.0V                                  | 50ma                    |
|                        | VSIM2    | 1.8V/3.0V                                  | 50ma                    |

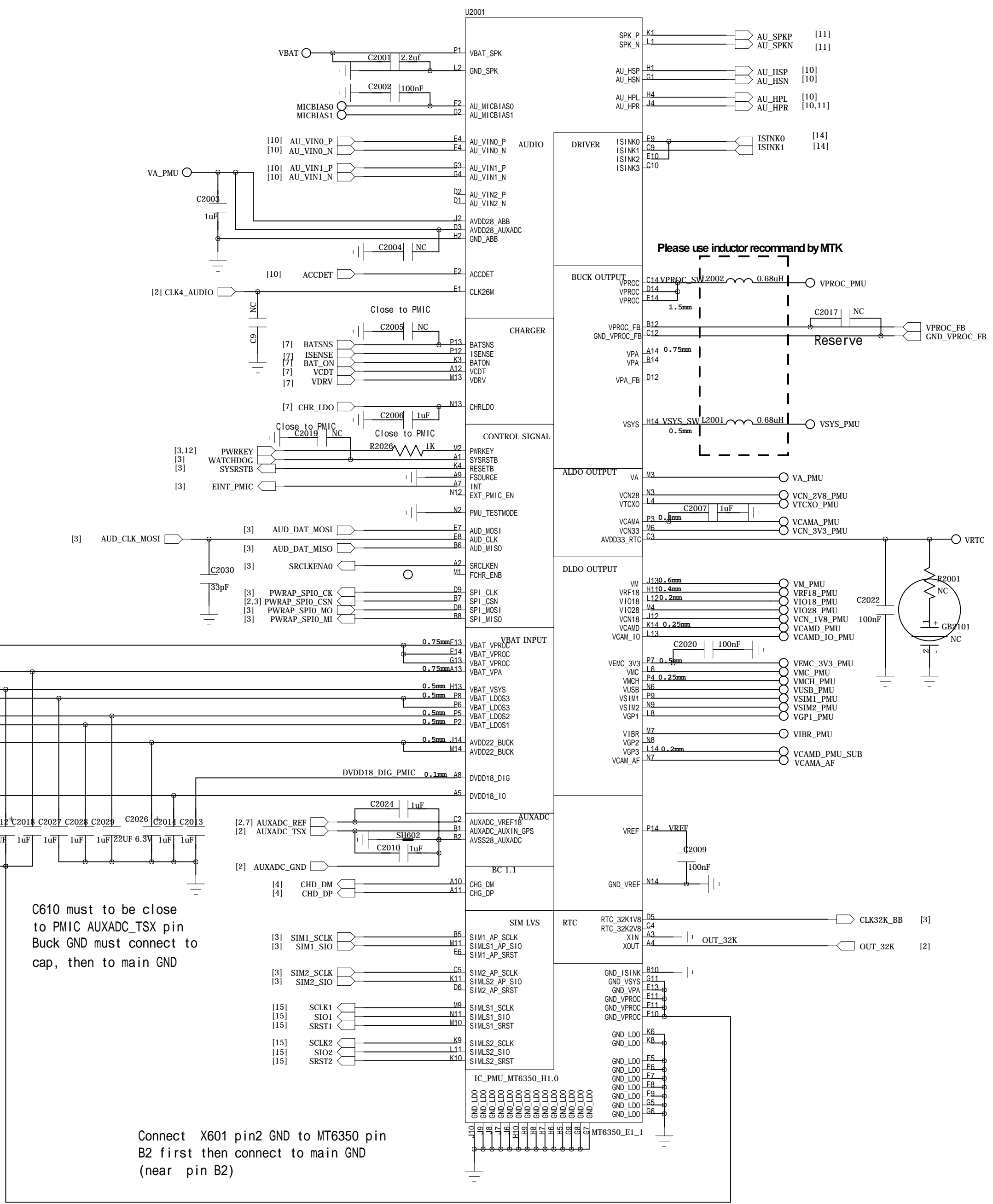
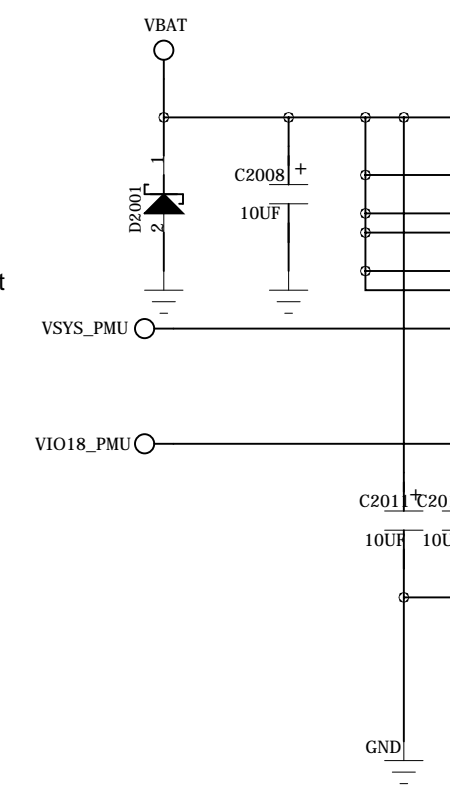

Add Zener Diode  
Place on the path  
from VBAT to IC  
(Battery connector  
or test point or I/O  
connector) Between IC and I/O port

C610 must to be close  
to PMIC AUXADC\_TSX pin  
Buck GND must connect to  
cap, then to main GND

Connect X601 pin2 GND to MT6350 pin  
B2 first then connect to main GND  
(near pin B2)

|                               |     |       |     |                 |  |                              |  |
|-------------------------------|-----|-------|-----|-----------------|--|------------------------------|--|
| COMPANY: TRANSSION TOP SECRET |     |       |     | MODEL: H8022    |  | Modified Date: 2018/1/12     |  |
| DRAWN                         | YQY | DATED | < > | TITLE: 6_MT6350 |  | VERSION: V1.0 SHEET: 6 OF 15 |  |
| CHECKED                       | < > | DATED | < > |                 |  |                              |  |

| REVISION RECORD |         |           |       |
|-----------------|---------|-----------|-------|
| LTR             | ECO NO: | APPROVED: | DATE: |
|                 |         |           |       |
|                 |         |           |       |
|                 |         |           |       |

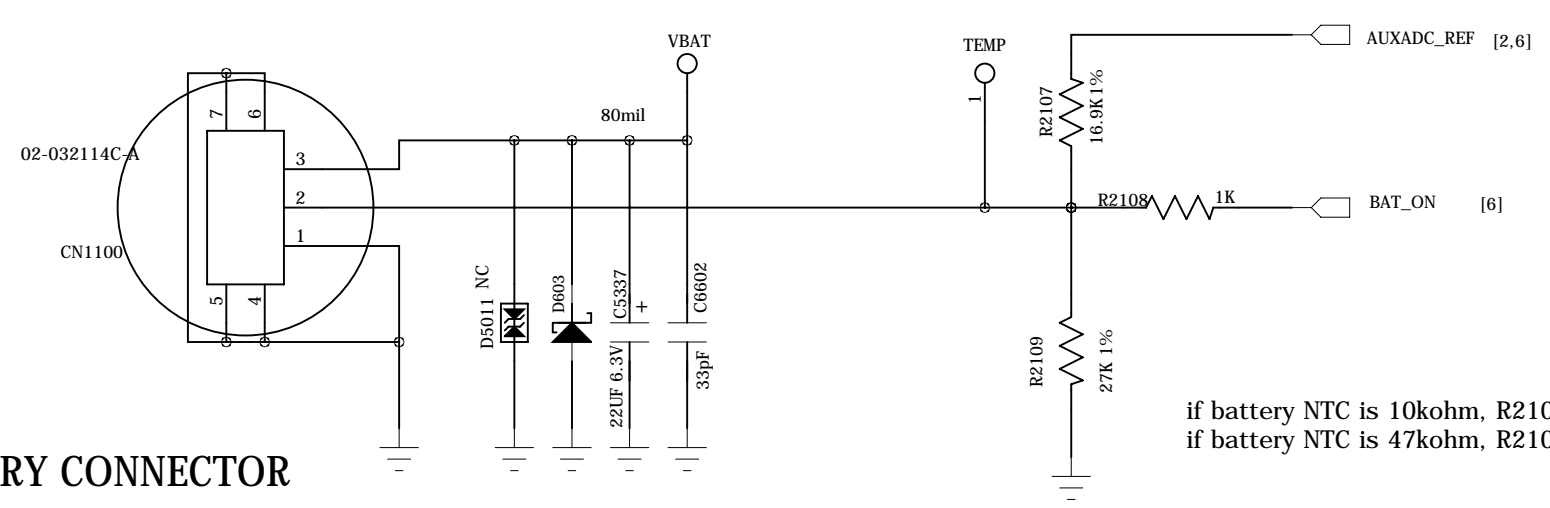
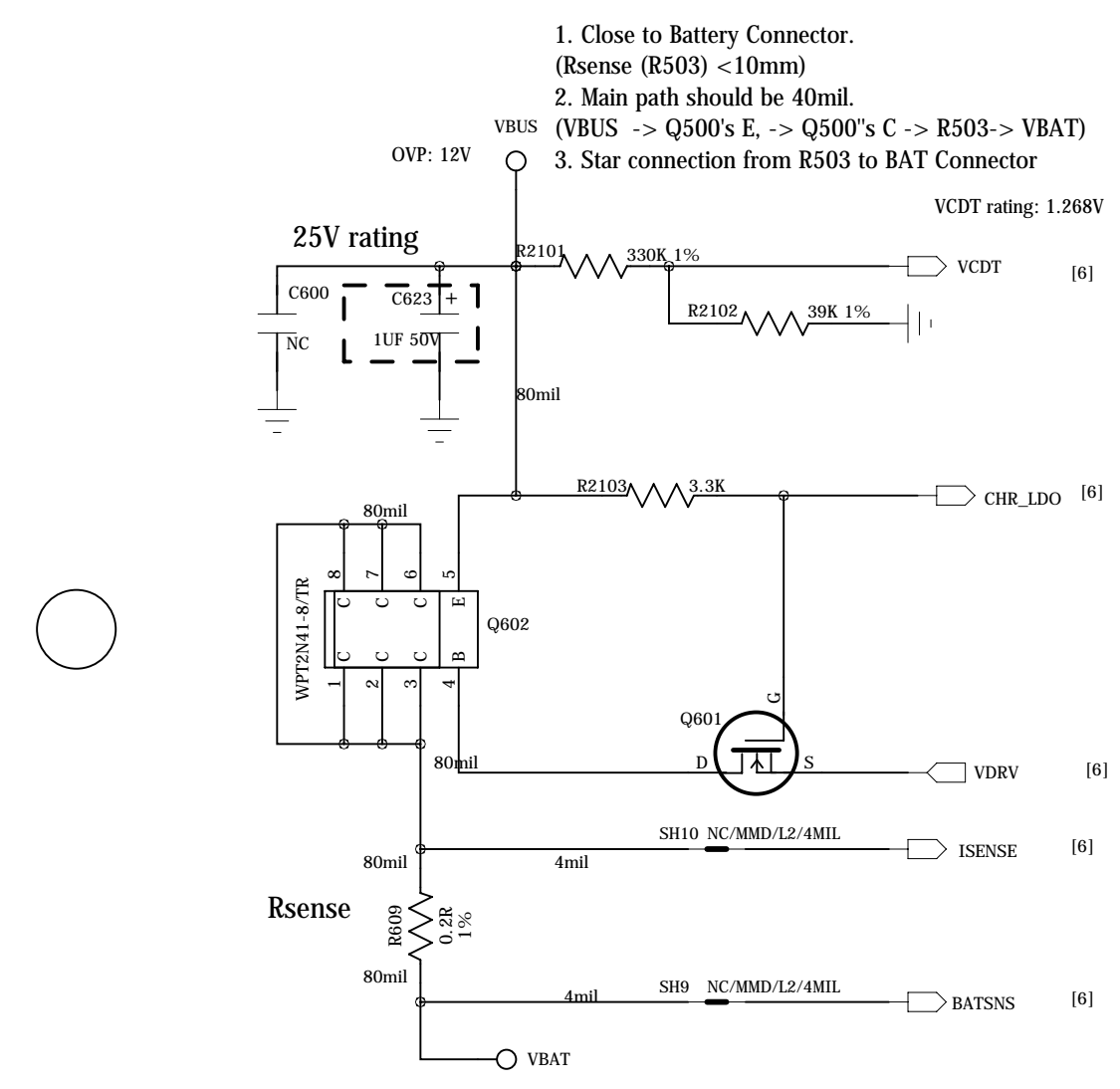

BATTERY CONNECTOR

|          |  |     |  |                      |  |                    |  |                              |  |
|----------|--|-----|--|----------------------|--|--------------------|--|------------------------------|--|
| COMPANY: |  |     |  | TRANSSION TOP SECRET |  | MODEL: H8022       |  | Modified Date: 2018/1/12     |  |
| DRAWN    |  | YQY |  | DATED < >            |  | TITLE: 7_BAT_SWCHR |  | VERSION: V1.0 SHEET: 7 OF 15 |  |
| CHECKED  |  | < > |  | DATED < >            |  |                    |  |                              |  |

| LTR | ECO NO: | APPROVED: | DATE: |
|-----|---------|-----------|-------|
|     |         |           |       |
|     |         |           |       |
|     |         |           |       |

# eMMC+LPDDR3

KMQ72000SM-B316

8GB+ 1GB

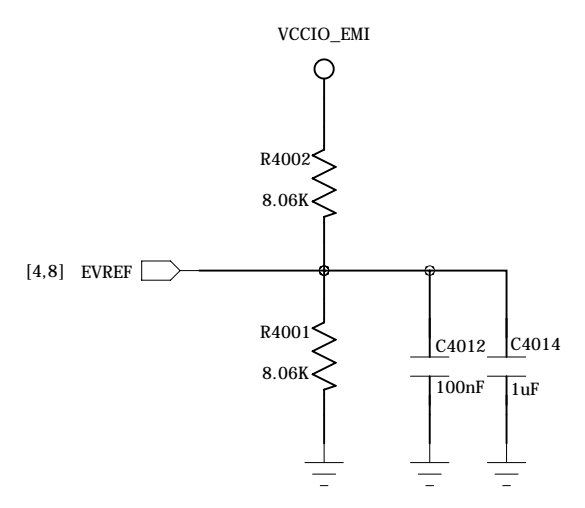
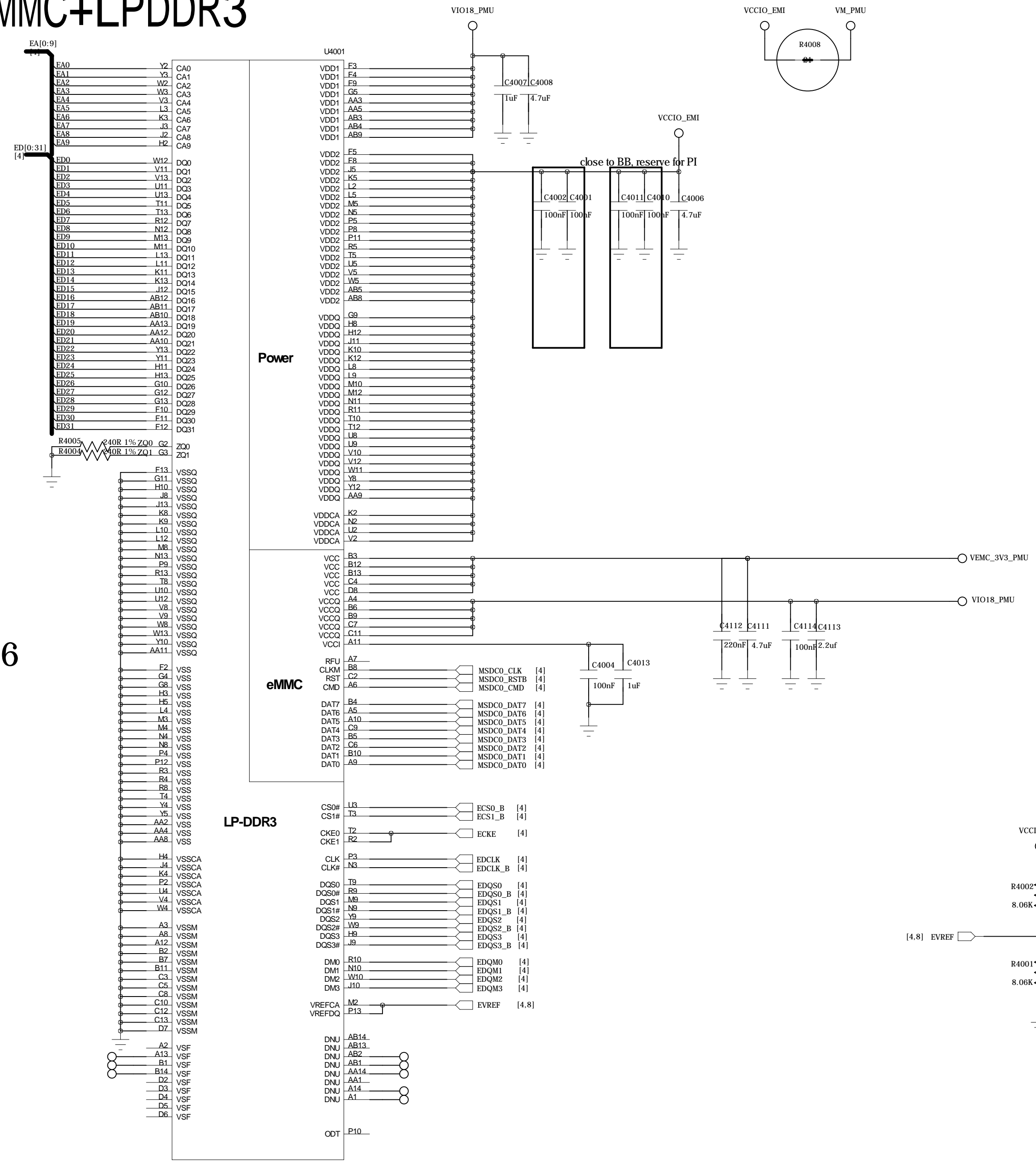

|                               |     |       |     |                 |  |                              |  |
|-------------------------------|-----|-------|-----|-----------------|--|------------------------------|--|
| COMPANY: TRANSSION TOP SECRET |     |       |     | MODEL: H8022    |  | Modified Date: 2018/1/12     |  |
| DRAWN                         | YQY | DATED | < > | TITLE: 8_MEMORY |  | VERSION: V1.0 SHEET: 8 OF 15 |  |
| CHECKED                       | < > | DATED | < > |                 |  |                              |  |



# WIFI/BT/GPS ANT

| REVISION RECORD |         |           |       |
|-----------------|---------|-----------|-------|
| LTR             | ECO NO: | APPROVED: | DATE: |
|                 |         |           |       |
|                 |         |           |       |
|                 |         |           |       |

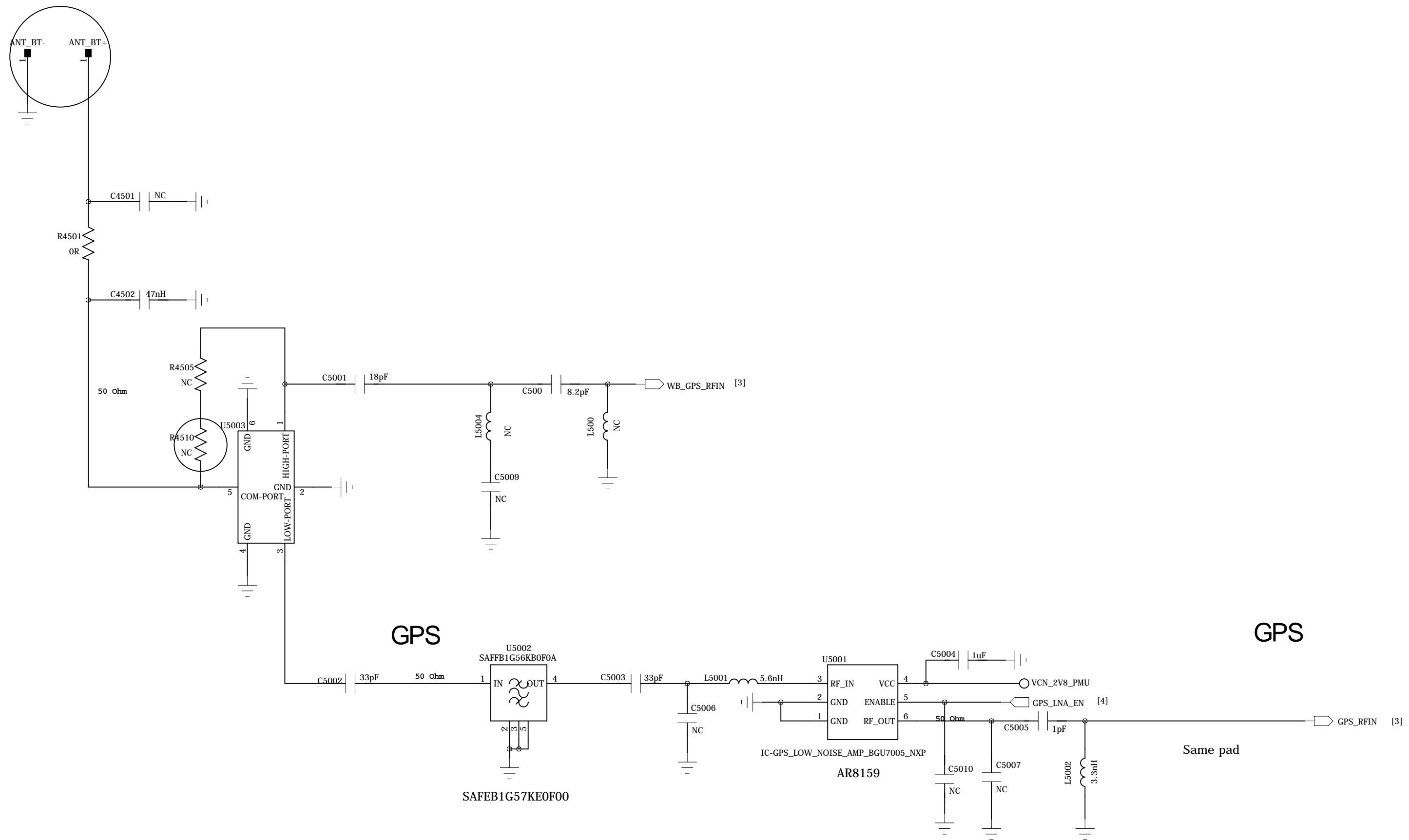

|          |     |       |     |                      |  |              |  |                          |                |
|----------|-----|-------|-----|----------------------|--|--------------|--|--------------------------|----------------|
| COMPANY: |     |       |     | TRANSSION TOP SECRET |  | MODEL: H8022 |  | Modified Date: 2018/1/12 |                |
| DRAWN    | YQY | DATED | < > | TITLE: 9_BT_GPS_WIFI |  |              |  | VERSION: V1.0            | SHEET: 9 OF 15 |
| CHECKED  | < > | DATED | < > |                      |  |              |  |                          |                |

| REVISION RECORD |         |           |       |
|-----------------|---------|-----------|-------|
| LTR             | ECO NO: | APPROVED: | DATE: |
|                 |         |           |       |
|                 |         |           |       |
|                 |         |           |       |

## MICOPHONE

Close to PMU

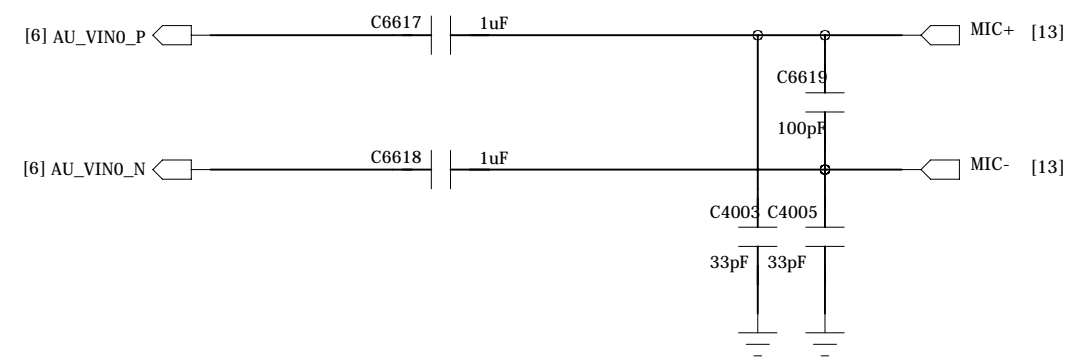

## RECEIVER

Close to Receiver

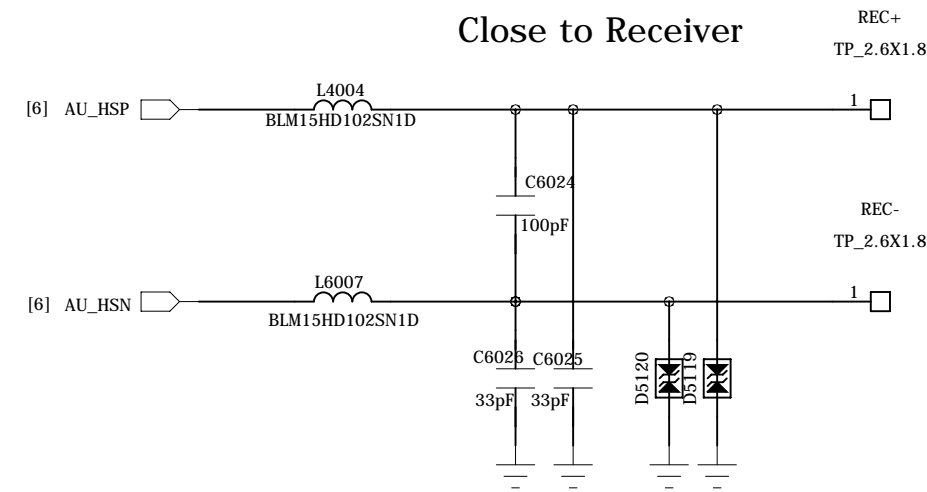

## HEADSET RECEIVER

close to IC

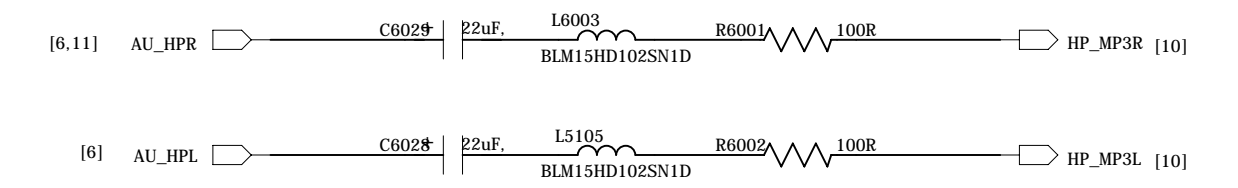

## 3.5mm Audio Jack

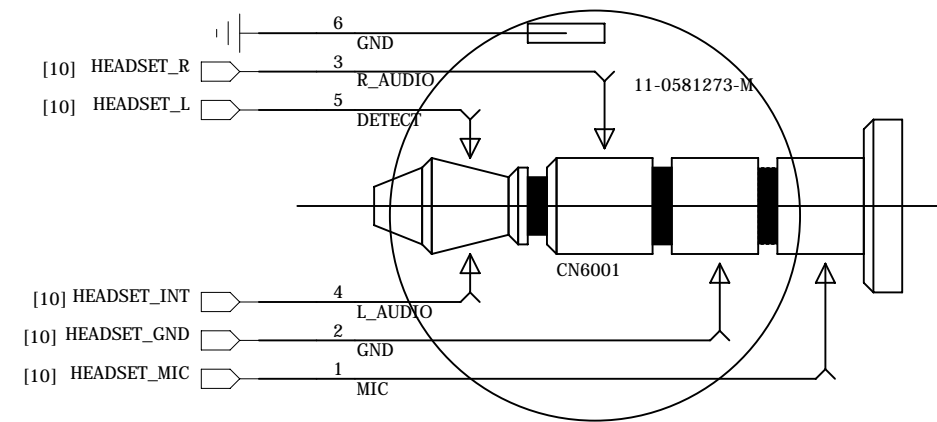
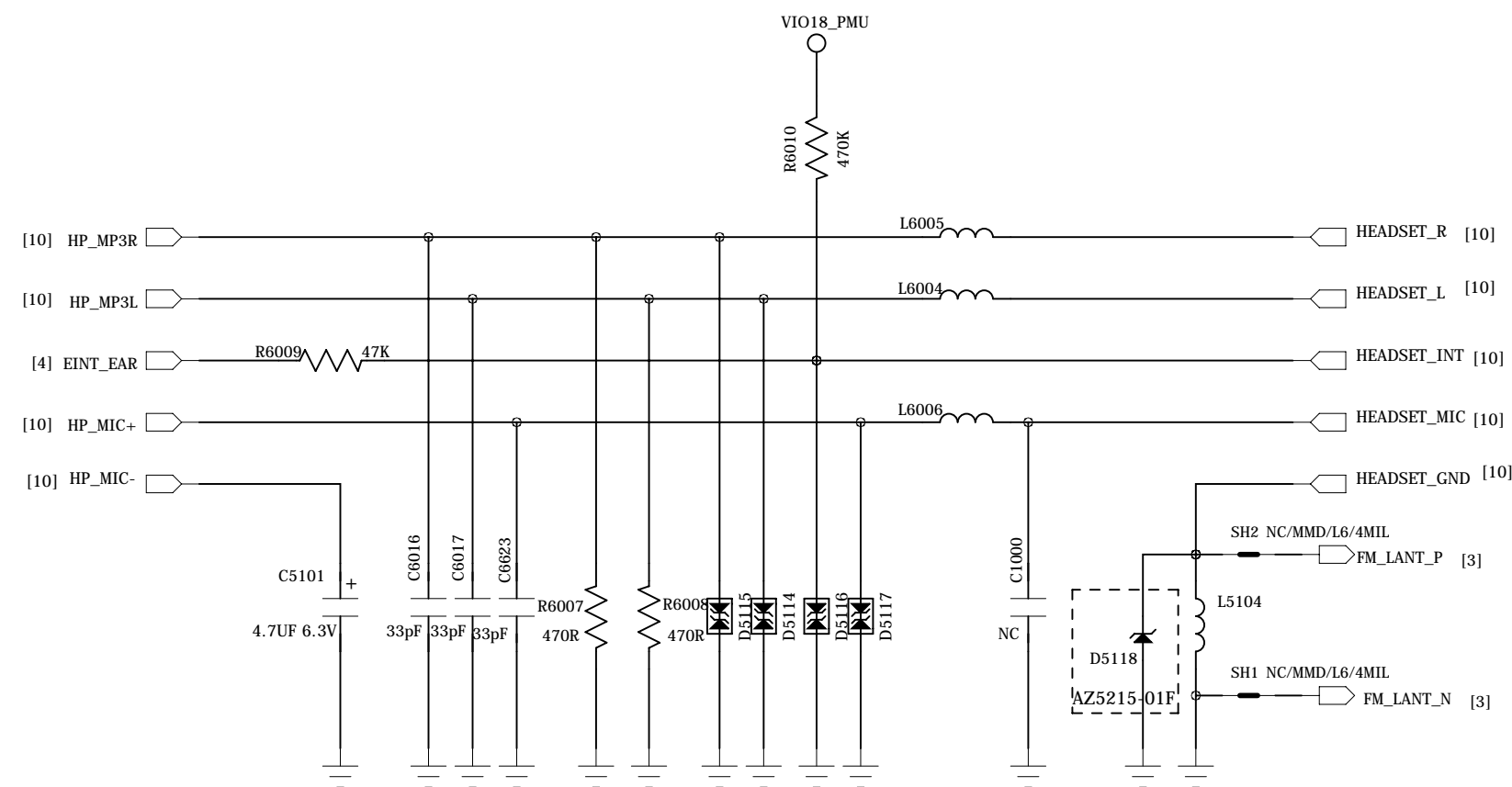

## HEADSET MIC

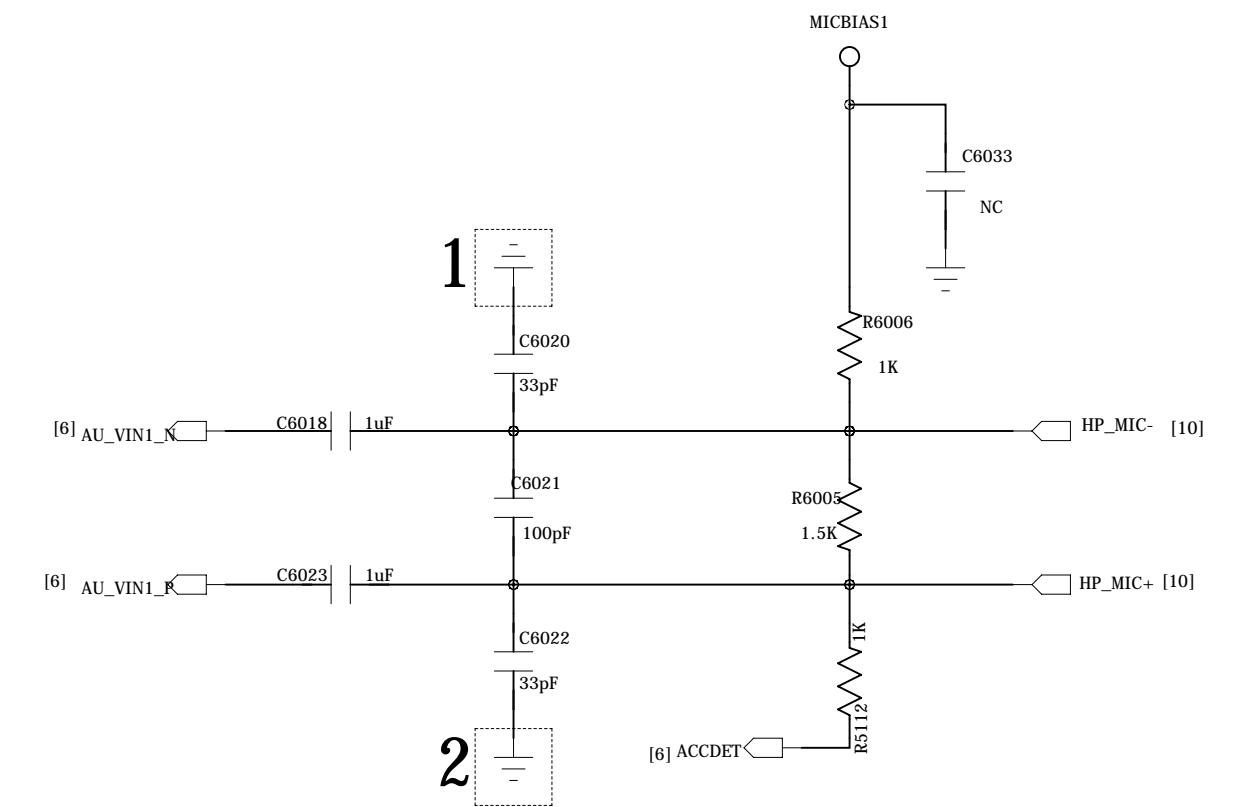

Close to PMU

|                      |     |       |     |
|----------------------|-----|-------|-----|
| COMPANY:             |     |       |     |
| TRANSSION TOP SECRET |     |       |     |
| DRAWN                | YQY | DATED | < > |
| CHECKED              | < > | DATED | < > |

|        |          |
|--------|----------|
| MODEL: | H8022    |
| TITLE: | 10_AUDIO |

|                |           |
|----------------|-----------|
| Modified Date: | 2018/1/12 |
| VERSION:       | V1.0      |
| SHEET:         | 10 OF 15  |

|     |         |           |      |
|-----|---------|-----------|------|
| LTR | ECO NO: | APPROVED: | DATE |
|     |         |           |      |
|     |         |           |      |
|     |         |           |      |

# Speaker

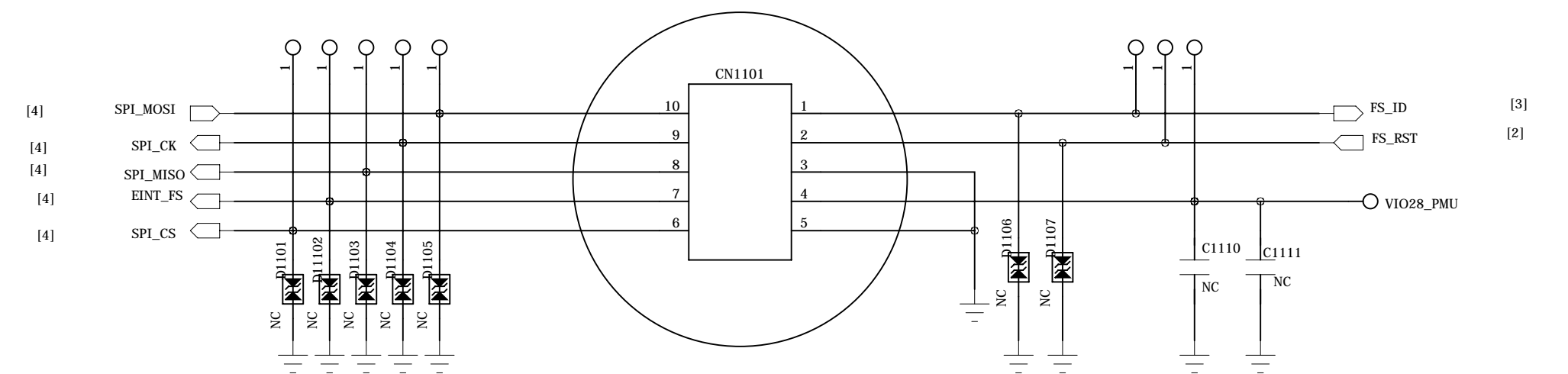
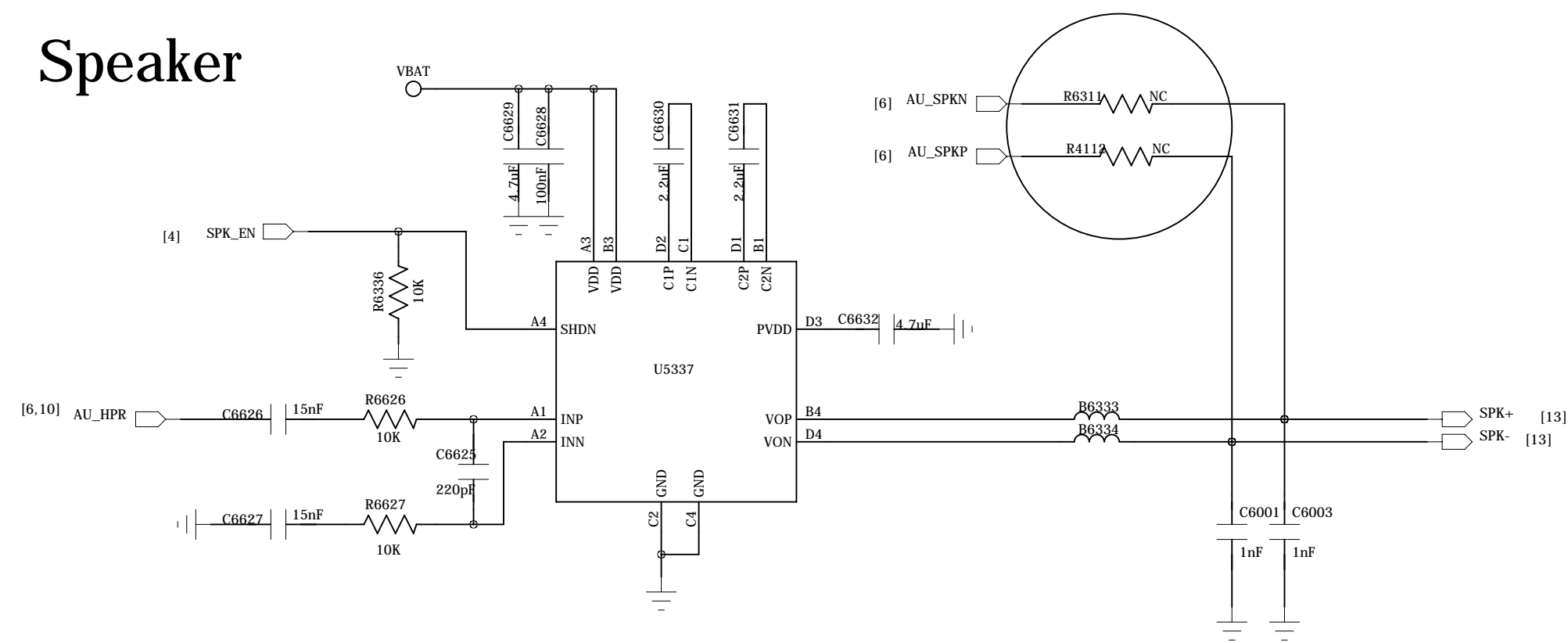

# Fingersensor

|                               |     |       |     |                  |  |                          |                 |
|-------------------------------|-----|-------|-----|------------------|--|--------------------------|-----------------|
| COMPANY: TRANSSION TOP SECRET |     |       |     | MODEL: H8022     |  | Modified Date: 2018/1/12 |                 |
| DRAWN                         | YQY | DATED | < > | TITLE: 11_SPK_FS |  | VERSION: V1.0            | SHEET: 11 OF 15 |
| CHECKED                       | < > | DATED | < > |                  |  |                          |                 |

| REVISION RECORD |         |           |       |
|-----------------|---------|-----------|-------|
| LTR             | ECO NO: | APPROVED: | DATE: |
|                 |         |           |       |
|                 |         |           |       |
|                 |         |           |       |

# KEYPAD

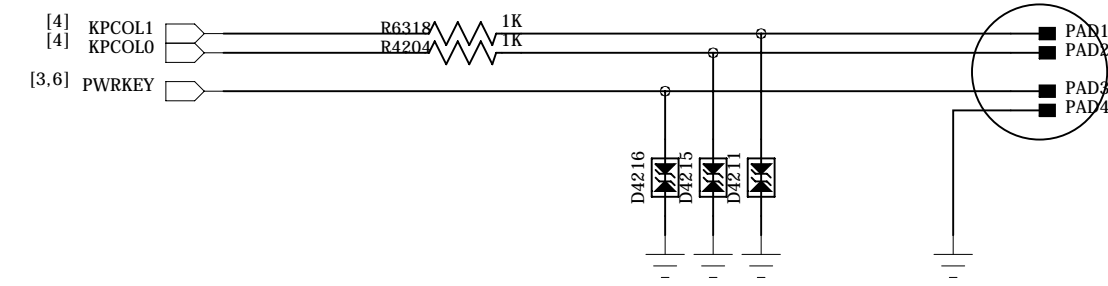

SIDE\_UP      GND/KPCOLO  
 SIDE\_DOWN    GND/KPCOL1

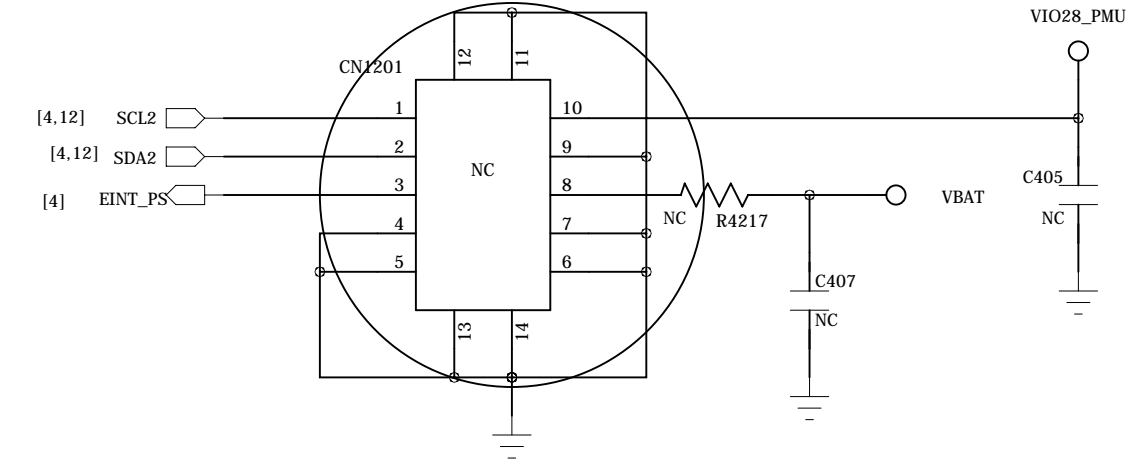
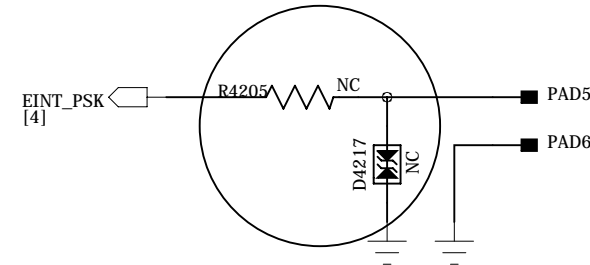

# G-Sensor      MXC4005 I2C ADDRESS:0x2AH(write) 0x2BH(read)

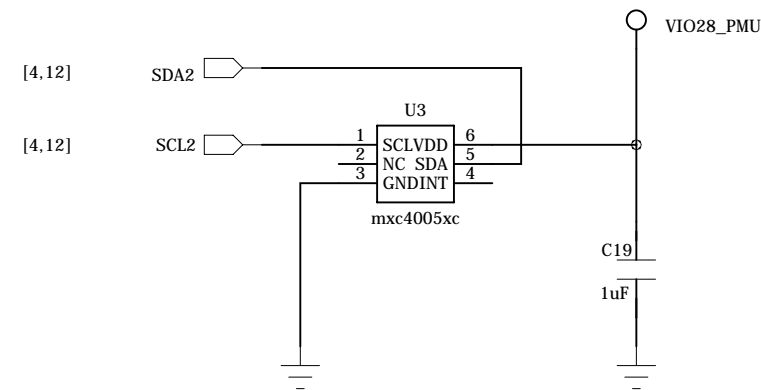

# NTC

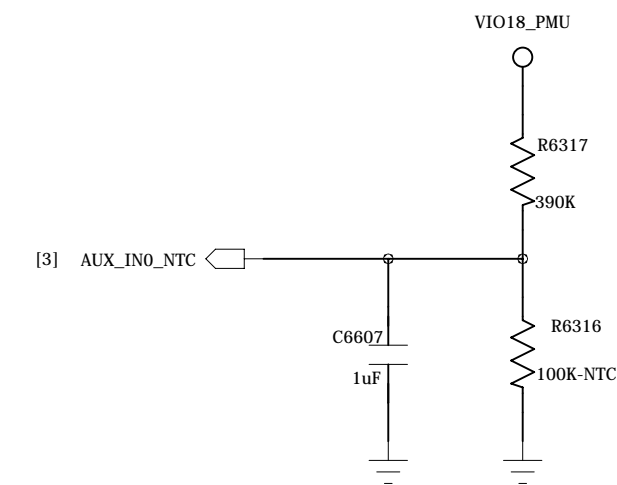

R6316 close to BB ,and located in the same layer

|              |  |              |  |                       |  |                     |  |                                 |  |
|--------------|--|--------------|--|-----------------------|--|---------------------|--|---------------------------------|--|
| COMPANY:     |  |              |  | TRANSSION TOP SECRET  |  | MODEL: <b>H8022</b> |  | Modified Date:        2018/1/12 |  |
| DRAWN    YQY |  | DATED    < > |  | TITLE: 12_KEY_SENSORS |  |                     |  | VERSION: V1.0                   |  |
| CHECKED < >  |  | DATED    < > |  |                       |  |                     |  | SHEET: 12 OF 15                 |  |

| REVISION RECORD |         |           |       |
|-----------------|---------|-----------|-------|
| LTR             | ECO NO: | APPROVED: | DATE: |
|                 |         |           |       |
|                 |         |           |       |
|                 |         |           |       |

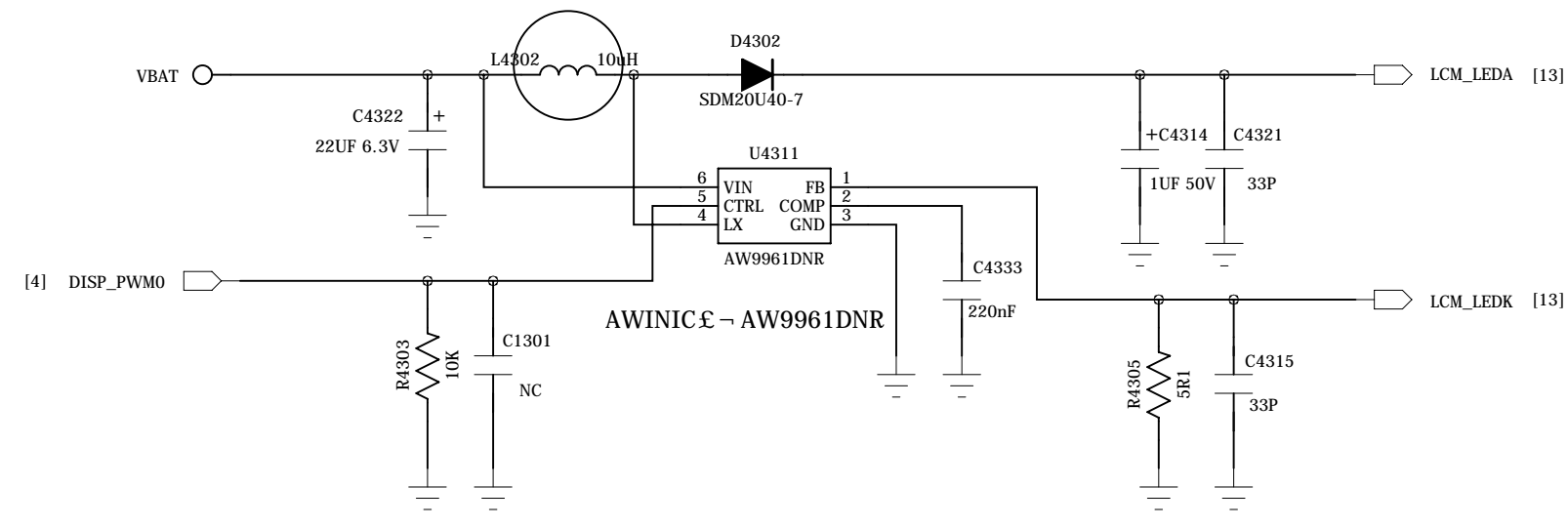

# LCD\_BACKLIGHT

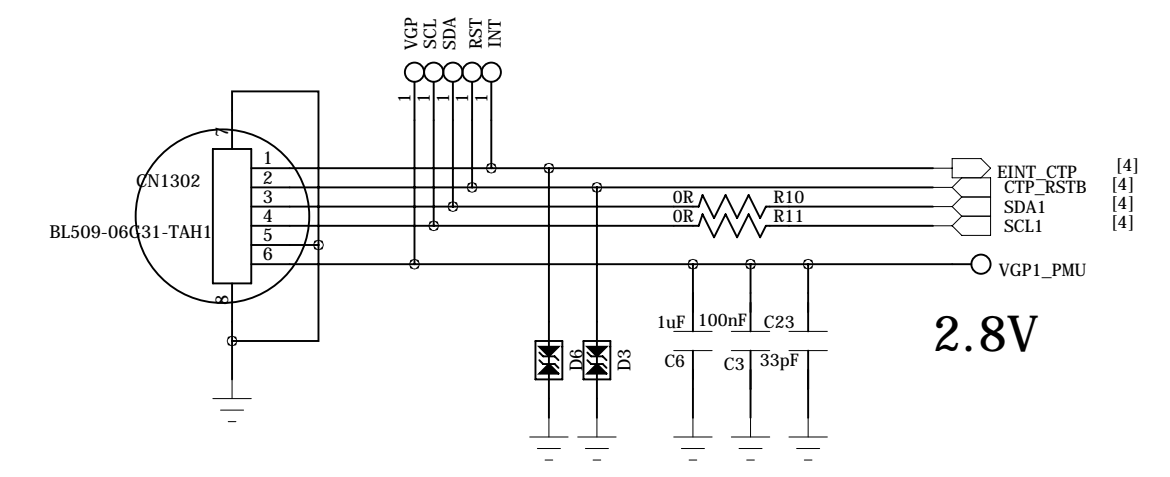

# CTP

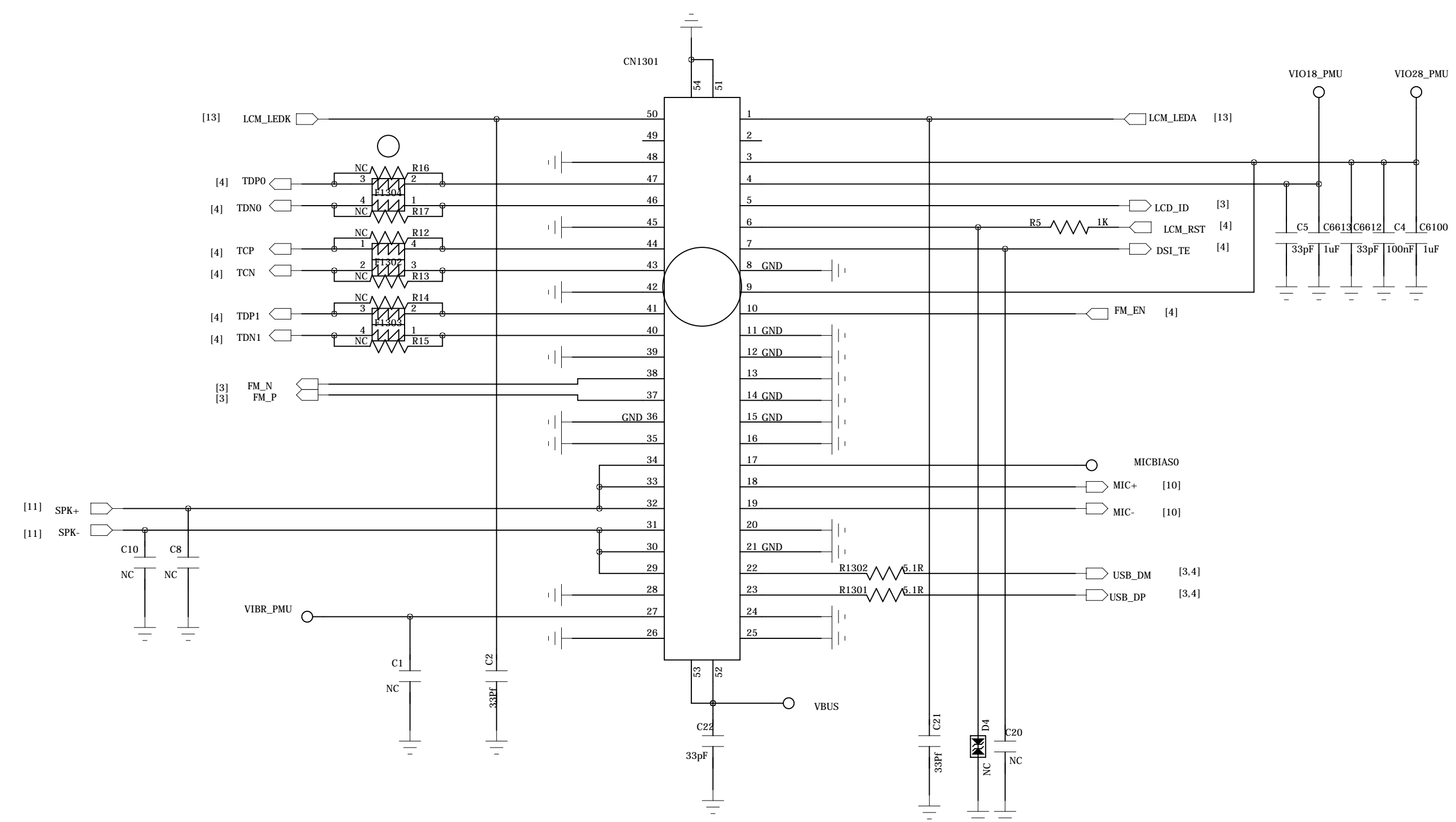

# LCD\_INTERFACE

|                              |     |       |     |                   |  |                               |  |
|------------------------------|-----|-------|-----|-------------------|--|-------------------------------|--|
| COMPANY: TRANSION TOP SECRET |     |       |     | MODEL: H8022      |  | Modified Date: 2018/1/12      |  |
| DRAWN                        | YQY | DATED | < > | TITLE: 13_LCD_CTP |  | VERSION: V1.0 SHEET: 13 OF 15 |  |
| CHECKED                      | < > | DATED | < > |                   |  |                               |  |

| REVISION RECORD |         |           |       |
|-----------------|---------|-----------|-------|
| LTR             | ECO NO: | APPROVED: | DATE: |
|                 |         |           |       |
|                 |         |           |       |
|                 |         |           |       |

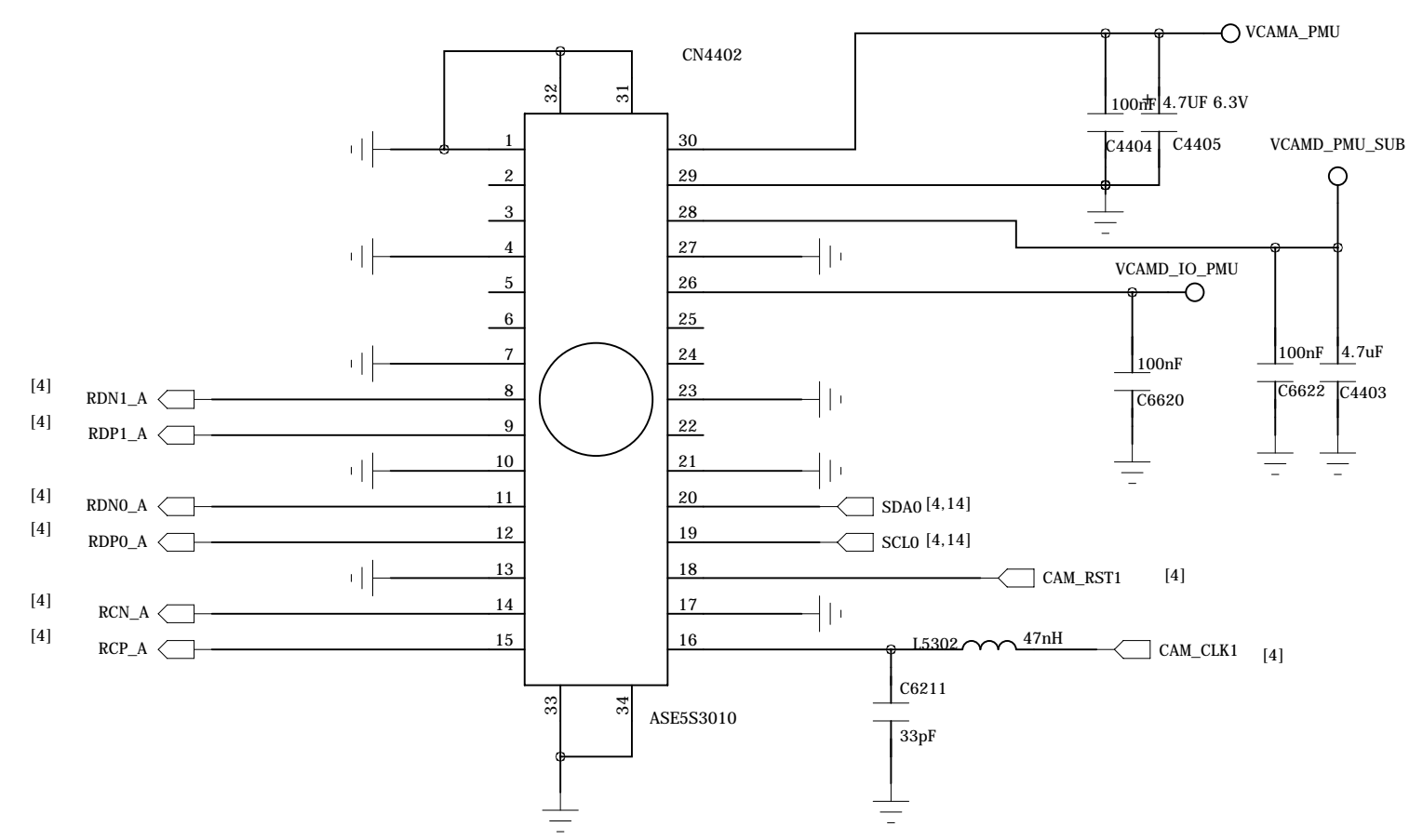

SUB CAMERA 5M

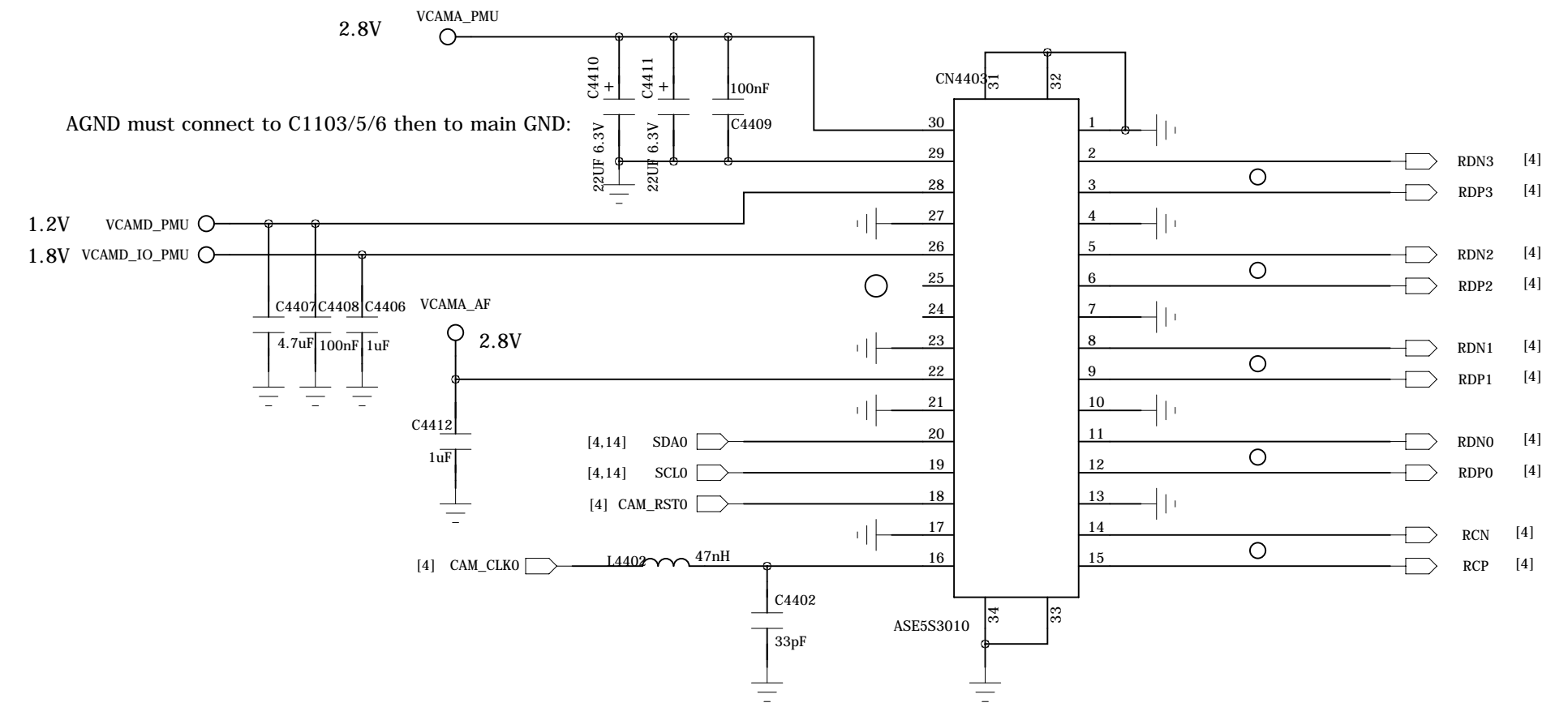

MAIN CAMERA (5M+AF)

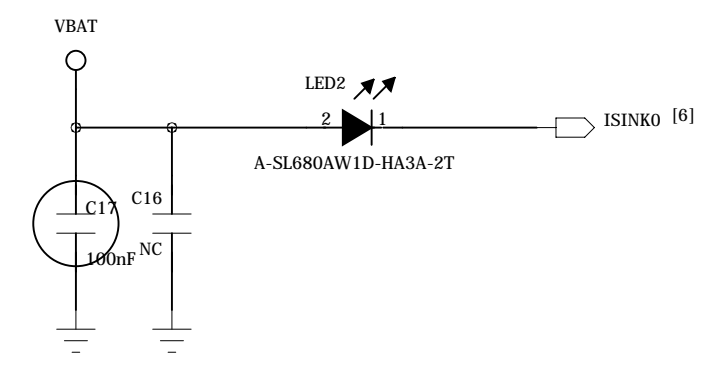

SUB CAMERA FLASH LED

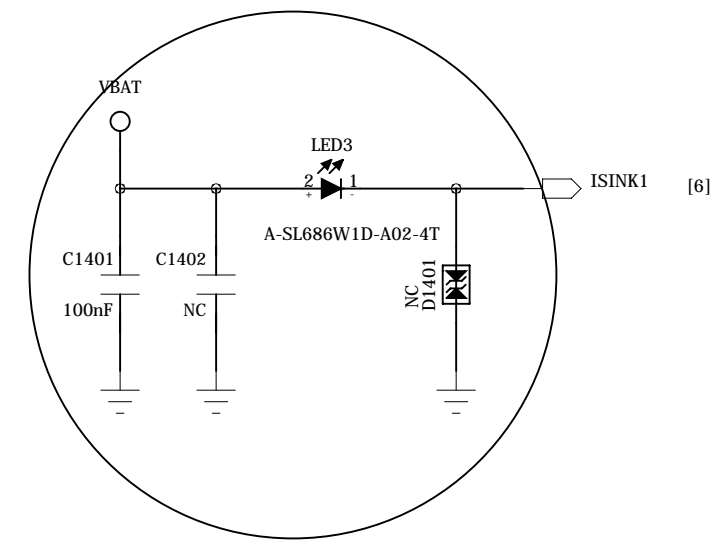

MAIN CAMERA FLASH LED

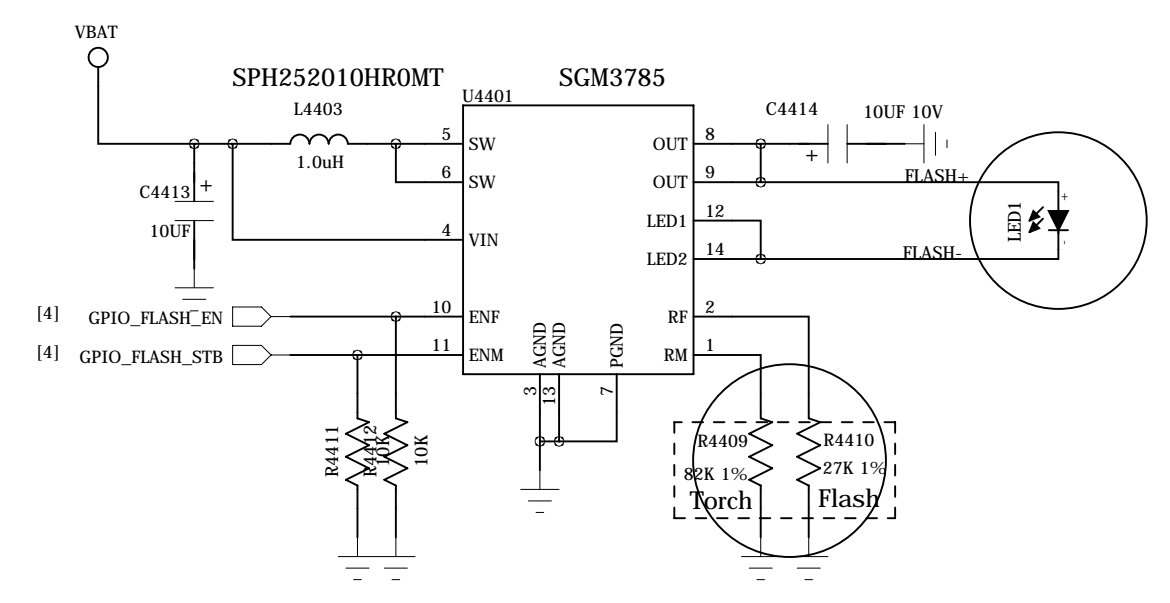

|                              |     |       |     |                  |  |                               |  |
|------------------------------|-----|-------|-----|------------------|--|-------------------------------|--|
| COMPANY: TRANSION TOP SECRET |     |       |     | MODEL: H8022     |  | Modified Date: 2018/1/12      |  |
| DRAWN                        |     | DATED | < > | TITLE: 14_CAMERA |  | VERSION: V1.0 SHEET: 14 OF 15 |  |
| CHECKED                      | < > | DATED | < > |                  |  |                               |  |

| REVISION RECORD |         |           |       |
|-----------------|---------|-----------|-------|
| LTR             | ECO NO: | APPROVED: | DATE: |
|                 |         |           |       |
|                 |         |           |       |
|                 |         |           |       |

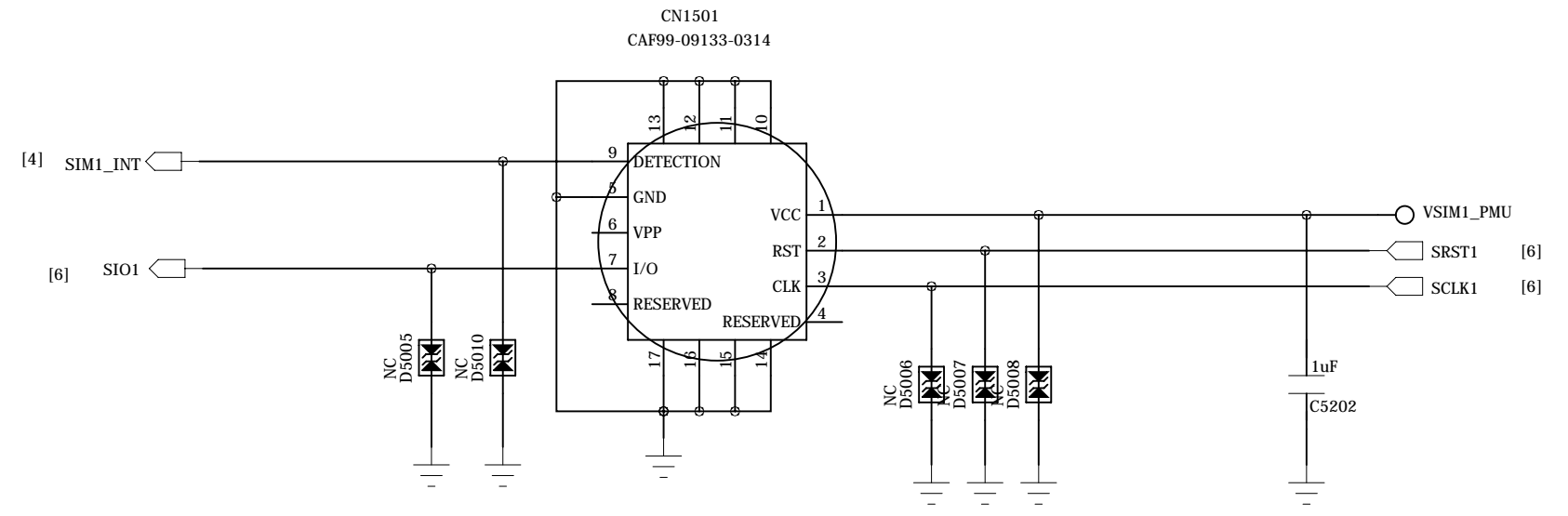

### SIM1 SOCKET

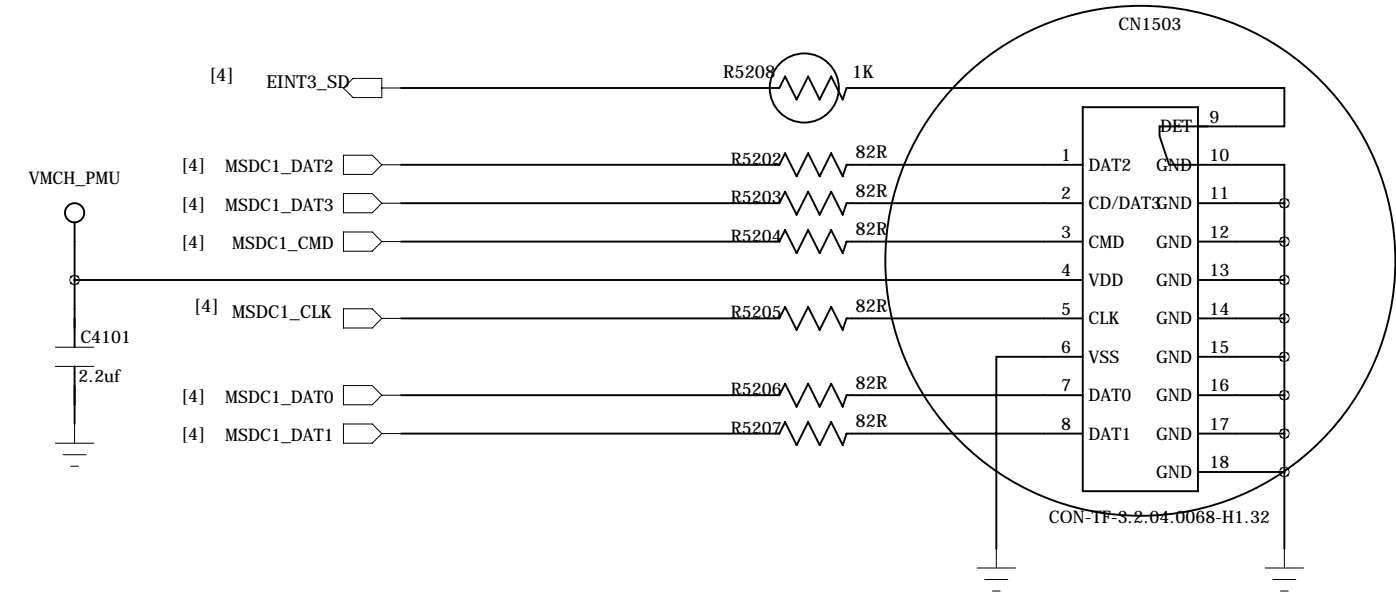

### T\_FLASH

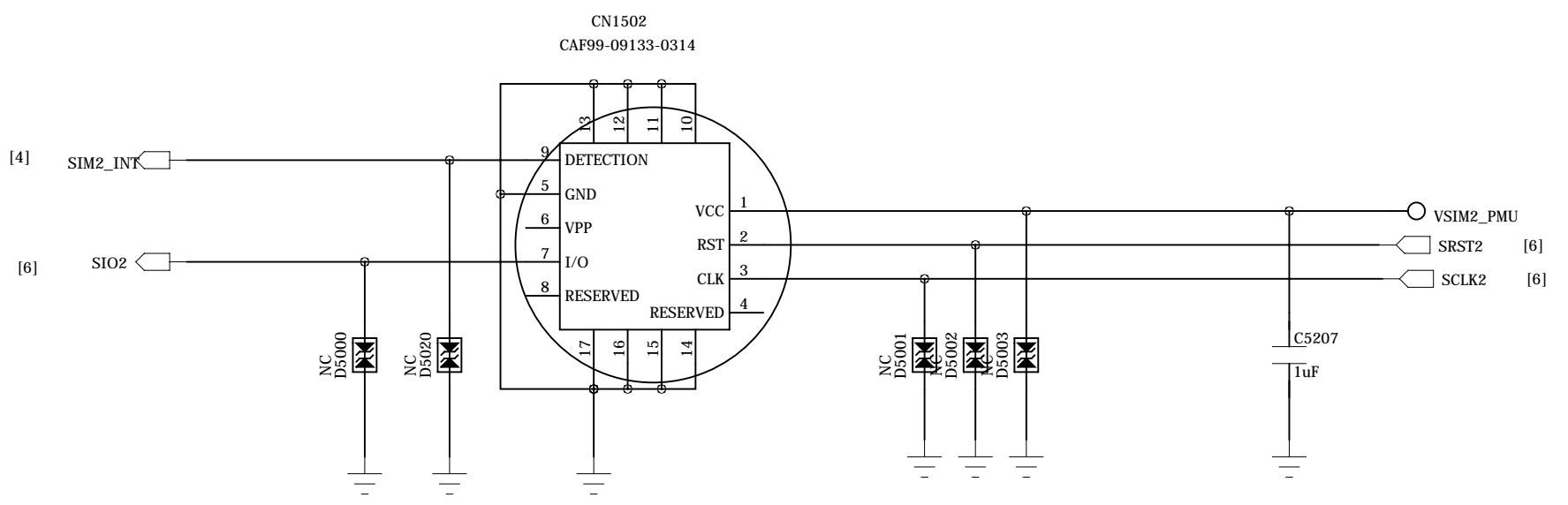

### SIM2 SOCKET

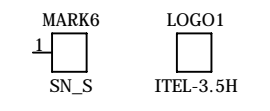
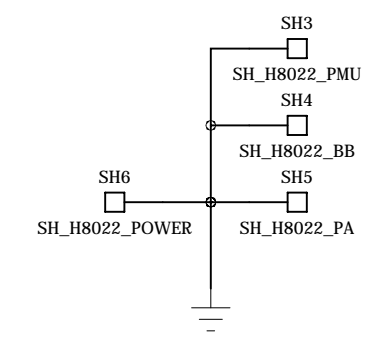
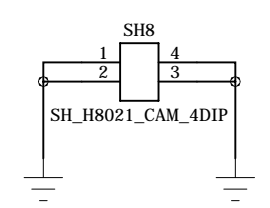
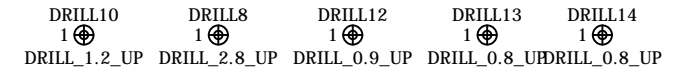
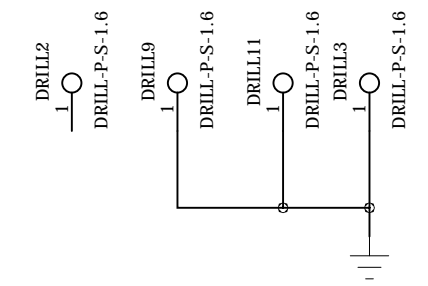

|                              |     |       |     |                       |  |                               |  |
|------------------------------|-----|-------|-----|-----------------------|--|-------------------------------|--|
| COMPANY: TRANSION TOP SECRET |     |       |     | MODEL: H8022          |  | Modified Date: 2018/1/12      |  |
| DRAWN                        | YQY | DATED | < > | TITLE: 15_SIM_T_FLASH |  | VERSION: V1.0 SHEET: 15 OF 15 |  |
| CHECKED                      | < > | DATED | < > |                       |  |                               |  |