



中认信通
CHINA CERTIFICATION ICT CO., LTD (DONGGUAN)



TEST REPORT

Applicant: TECNO MOBILE LIMITED

Address: FLAT N 16/F BLOCK B UNIVERSAL INDUSTRIAL CENTRE 19-25
SHAN MEI STREET FOTAN NT HONGKONG

FCC ID: 2ADYY-CL9

Product Name: Mobile Phone

Standard(s): 47 CFR Part 2, 47 CFR Part 22, Subpart H
47 CFR Part 24, Subpart E
47 CFR Part 27
ANSI C63.26-2015

The above device has been tested and found compliant with the requirement of the relative standards by China Certification ICT Co., Ltd (Dongguan)

Report Number: CR230745209-00G

Date Of Issue: 2024/1/18

Reviewed By: Julie Tan

Julie Tan

Title: RF Engineer

Approved By: Sun Zhong

Sun Zhong

Title: Manager

Test Laboratory: China Certification ICT Co., Ltd (Dongguan)

No. 113, Pingkang Road, Dalang Town, Dongguan,
Guangdong, China
Tel: +86-769-82016888

Test Facility

The Test site used by China Certification ICT Co., Ltd (Dongguan) to collect test data is located on the No. 113, Pingkang Road, Dalang Town, Dongguan, Guangdong, China.

The lab has been recognized as the FCC accredited lab under the KDB 974614 D01 and is listed in the FCC Public Access Link (PAL) database, FCC Registration No. : 442868, the FCC Designation No. : CN1314.

The lab has been recognized by Innovation, Science and Economic Development Canada to test to Canadian radio equipment requirements, the CAB identifier: CN0123.

Declarations

China Certification ICT Co., Ltd (Dongguan) is not responsible for the authenticity of any test data provided by the applicant. Data included from the applicant that may affect test results are marked with a triangle symbol “▲”. Customer model name, addresses, names, trademarks etc. are not considered data.

Unless otherwise stated the results shown in this test report refer only to the sample(s) tested.

This report cannot be reproduced except in full, without prior written approval of the Company.

This report is valid only with a valid digital signature. The digital signature may be available only under the Adobe software above version 7.0.

This report may contain data that are not covered by the accreditation scope and shall be marked with an asterisk “★”.

CONTENTS

DOCUMENT REVISION HISTORY	4
1. GENERAL INFORMATION	5
1.1 PRODUCT DESCRIPTION FOR EQUIPMENT UNDER TEST (EUT)	5
1.2 DESCRIPTION OF TEST CONFIGURATION.....	10
1.3 MEASUREMENT UNCERTAINTY	11
2. SUMMARY OF TEST RESULTS	12
3. REQUIREMENTS AND TEST PROCEDURES	13
3.1 Applicable Standard For Part 22 Subpart H:.....	13
3.2 Applicable Standard For Part 24 Subpart E:	15
3.3 Applicable Standard For Part 27:.....	16
3.4 Test Method:	20
4. Test DATA AND RESULTS	27
4.1 ANTENNA PORT TEST DATA AND RESULTS:	27
4.2 RADIATED SPURIOUS EMISSIONS.....	28
5. EUT PHOTOGRAPHS	43
6. TEST SETUP PHOTOGRAPHS	44

DOCUMENT REVISION HISTORY

Revision Number	Report Number	Description of Revision	Date of Revision
1.0	CR231165634-00G	Original Report	2024/1/18

1. GENERAL INFORMATION

1.1 Product Description for Equipment under Test (EUT)

EUT Name:	Mobile Phone
Trade Name:	Tecno
EUT Model:	CL9
Operation Bands:	5G NR SA Band: n5/n7/n12/n38/40/41//66/77/78 5G NR NSA Band: DC_4A_n38A, DC_5A_n38A, DC_66A_n38A, DC_5A_n40A DC_7A_n40A, DC_40A-n40A, DC_4A-n41A, DC_5A-n41A DC_40A-n41A, DC_41A-n41A DC_66A-n41A, DC_2A-n66A, DC_5A-n66A, DC_7A-n66A, DC_66A-n66A DC_5A-n77A, DC_7A-n77A, DC_40A-n77A, DC_41A-n77A DC_66A-n77A, DC_2A-n78A, DC_4A-n78A, DC_5A-n78A DC_7A-n78A, DC_38A-n78A, DC_40A-n78A/ DC_41A-n78A DC_66A-n78A, DC_2A_n7A, DC_5A_n7A, DC_7A_n7A DC_66A_n7A
Modulation Type:	DFT-s-OFDM: PI/2 BPSK, QPSK, 16QAM, 64QAM, 256QAM CP-OFDM: QPSK, 16QAM, 64QAM, 256QAM
Rated Input Voltage:	DC 3.87V from battery or DC 5/9/12/15/20/11V from adapter
Serial Number:	RF Conducted:2BCU-1 Radiated Spurious Emissions: 2BCU-2
EUT Received Date:	2023/11/8
EUT Received Status:	Good
Note: For NSA mode, we only show the combination of the maximum power among all NSA combinations in the report as below: DC_5A_n7A, DC_5A_n38A, DC_40A_n40A, DC_5A_n41A, DC_2A_n66A, DC_41A_n77A, DC_5A_n78A	

Operation Voltage (V_{DC}) ▲:

Lowest:	3.45	Normal:	3.91	Highest:	4.5
---------	------	---------	------	----------	-----

Operation Frequency and Test Frequency Detail:

Bands	Frequency Range (MHz)	Bandwidth (MHz)	Test Frequency (MHz)		
			Low Channel	Middle Channel	High Channel
N5	824-849	5	826.5	836.5	846.5
		10	829.0	836.5	844.0
		15	831.5	836.5	841.5
		20	834.0	836.5	839.0
N7	2500-2570	5	2502.5	2535	2567.5
		10	2505.0	2535	2565.0
		15	2507.5	2535	2562.5

		20	2510.0	2535	2560.0
N12	699-716	5	701.5	707.5	713.5
		10	704.0	707.5	711.0
		15	706.5	707.5	708.5

Bands	Frequency Range (MHz)	Bandwidth (MHz)	Test Frequency (MHz)		
			Low Channel	Middle Channel	High Channel
N38	2570-2620	5	2572.5	2595	2617.5
		10	2575	2595	2615
		15	2577.5	2595	2612.5
		20	2580	2595	2610
		40	2590.0	2595.0	2600
N40 Lower	2305-2315	5	2307.5	/	2312.5
		10	/	2310	/
N40 Upper	2350-2360	5	2352.5	/	2357.5
		10	/	2355	/
N41	2496-2690	10	2501.01	2592.99	2685
		15	2503.5	2592.99	2682.48
		20	2506.02	2592.99	2679.99
		30	2511.00	2592.99	2674.99
		40	2516.01	2592.99	2670.00
		50	2521.02	2592.99	2664.99
		60	2526.00	2592.99	2659.99
		80	2536.02	2592.99	2649.99
		90	2541.0	2592.99	2644.98
		100	2546.01	2592.99	2640.00
N66	1710-1780	5	1712.5	1745	1777.5
		10	1715	1745	1775
		15	1717.5	1745	1772.5
		20	1720	1745	1770
		25	1722.5	1745	1767.5
		30	1725	1745	1765
		40	1730	1745	1760

Bands	Frequency Range (MHz)	Bandwidth (MHz)	Test Frequency (MHz)		
			Low Channel	Middle Channel	High Channel
N77/N78 Lower	3450-3550	10	3455.0	3500.0	3545.0
		15	3457.5	3500.0	3542.5
		20	3460.0	3500.0	3540.0
		30	3465.0	3500.0	3535.0
		40	3470.0	3500.0	3530.0
		50	3475.0	3500.0	3525.0
		60	3480.0	3500.0	3520.0
		70	3485.0	3500.0	3515.0
		80	3490.0	3500.0	3510.0
		90	3495.0	3500.0	3405.0
		100	/	3500.0	/
N77/N78 Upper	3700-3980	10	3705.00	3840.00	3975.00
		15	3707.50	3840.00	3972.50
		20	3710.00	3840.00	3970.00
		30	3715.00	3840.00	3965.00
		40	3720.00	3840.00	3960.00
		50	3725.00	3840.00	3955.00
		60	3730.00	3500.0	3950.00
		70	3735.00	3500.0	3945.00
		80	3740.00	3500.0	3940.00
		90	3745.00	3500.0	3935.00
		100	3750.00	3500.0	3930.00

Note:

n78(3450-3500MHz and 3700-3800MHz) was covered by n77, they have the same output power and supported bandwidth, so only tests n77.

SCS 15kHz, 30kHz, 60kHz was supports by the device, they have same output power. so only SCS 15kHz was tested for FDD band, and CSC 30kHz tested for TDD band.

For modulation of CP-OFDM and DFT-s-OFDM, the maximum power of CP-OFDM is lower than DFT-s-OFDM modulation, therefore, we chose higher power (DFT-s-OFDM modulation) to perform all tests and show in the report

Transmission Antenna Information ▲ :

Antenna	Antenna Manufacturer	Antenna Type	Operation Bands	Antenna Frequency Range (MHz)	Antenna Gain (G _T) (dBi)	L _c (dB)
ANT 1	Shangyuan Technology (China) Co.,Ltd.	LDS	LTE B5/N5	824-849	-8.3	0.2
			LTE B12/N12	699-716	-9.8	0.2
			LTE B17	704-716	-9.8	0.2
ANT 2	Shangyuan Technology (China) Co.,Ltd.	LDS	LTE B2	1850-1910	-6.5	0.2
			LTE B4	1710-1755	-6.2	0.2
			LTE B7/N7	2500-2570	-5.2	0.2
			LTE B38/N38	2570-2620	-5.2	0.2
			LTE B40 Lower /N40 Lower	2305-2315	-5.1	0.2
			LTE B40 Upper /N40 Upper	2350-2360	-5.1	0.2
			LTE B41/ N41	2535-2655	-5.2	0.2
LTE B66/N66	1710-1785	-6.2	0.2			
ANT7	Shangyuan Technology (China) Co.,Ltd.	LDS	N77	3300-4200	-5.8	N/A
			N78	3300-3800	-5.8	N/A

Note: L_c= Signal Attenuation in the connecting cable between the transmitter and antenna, in dB.

Accessory Information:

Accessory Description	Manufacturer	Model	Parameters
Adapter	Unknown	U700TSA	Input: 100-240Vac 50/60Hz 2.0A Output: 5.0Vdc 3.0A 15.0W or 5.0-10.0Vdc 7.0A MAX or 11.0Vdc 6.4A MAX or 4.0-20.0Vdc 3.5A 70.0W MAX

1.2 Description of Test Configuration

1.2.1 EUT Operation Condition:

EUT Operation Mode:	The system was configured for testing in each operation mode.
Equipment Modifications:	No
EUT Exercise Software:	No
The maximum power was configured per 3GPP Standard for each operation modes.	

1.2.2 Support Equipment List and Details

Manufacturer	Description	Model	Serial Number
Keysight	UXM 5G Wireless Test Platform	E7515B	MY58120285
Unknown	ANTENNA	Unknown	Unknown

1.2.3 Support Cable List and Details

Cable Description	Shielding Type	Ferrite Core	Length (m)	From Port	To
/	/	/	/	/	/

1.2.4 Block Diagram of Test Setup

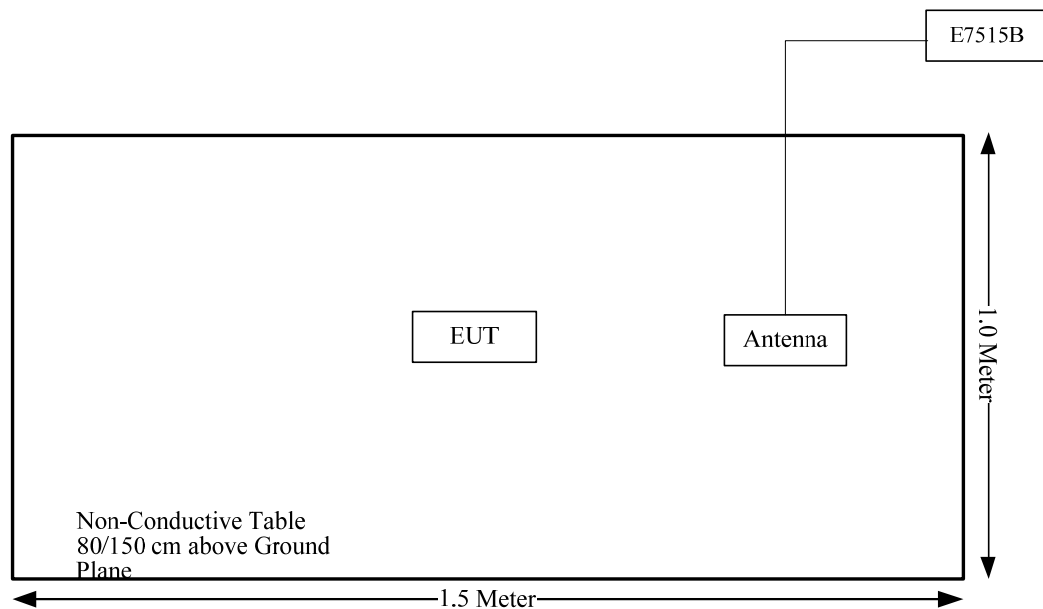

1.3 Measurement Uncertainty

Otherwise required by the applicant or Product Regulations, Decision Rule in this report did not consider the uncertainty. The extended uncertainty given in this report is obtained by combining the standard uncertainty times the coverage factor K with the 95% confidence interval.

Parameter	Measurement Uncertainty
Occupied Channel Bandwidth	±5 %
RF output power, conducted	±0.61dB
Power Spectral Density, conducted	±0.61 dB
Unwanted Emissions, radiated	30M~200MHz: 4.15 dB,200M~1GHz: 5.61 dB,1G~6GHz: 5.14 dB, 6G~18GHz: 5.93 dB,18G~26.5G:5.47 dB,26.5G~40G:5.63 dB
Unwanted Emissions, conducted	±1.26 dB
Temperature	±1 °C
Humidity	±5%
DC and low frequency voltages	±0.4%
Duty Cycle	1%
RF Frequency	±0.082×10 ⁻⁶

2. SUMMARY OF TEST RESULTS

Rules	Description of Test	Result
FCC§2.1046; § 22.913; § 24.232; §27.50	RF Output Power	Compliant
FCC§ 2.1047	Modulation Characteristics	Not Applicable
FCC§ 2.1049; § 22.905; § 22.917; § 24.238; §27.53	Occupied Bandwidth	Compliant
FCC§ 2.1051; § 22.917; § 24.238; §27.53	Spurious Emissions at Antenna Terminal	Compliant
FCC§ 22.917; § 24.238; §27.53	Out of band emission, Band Edge	Compliant
FCC§ 2.1055; § 22.355; § 24.235; §27.54	Frequency stability vs. temperature Frequency stability vs. voltage	Compliant
FCC§ 2.1053; § 22.917; § 24.238; §27.53	Field Strength of Spurious Radiation	Compliant

3. REQUIREMENTS AND TEST PROCEDURES

3.1 Applicable Standard For Part 22 Subpart H:

3.1.1 RF Output Power

FCC §22.913

(a)(5) The ERP of mobile transmitters and auxiliary test transmitters must not exceed 7watts.

(d) *Power measurement.* Measurement of the ERP of Cellular base transmitters and repeaters must be made using an average power measurement technique. The peak-toaverage ratio (PAR) of the transmission must not exceed 13 dB. Power measurements for base transmitters and repeaters must be made in accordance with either of the following:

- (1) A Commission-approved average power technique (*see* FCC Laboratory's Knowledge Database); or
- (2) For purposes of this section, peak transmit power must be measured over an interval of continuous transmission using instrumentation calibrated in terms of an rmsequivalent voltage. The measurement results shall be properly adjusted for any instrument limitations, such as detector response times, limited resolution bandwidth capability when compared to the emission bandwidth, sensitivity, *etc.*, so as to obtain a true peak measurement for the emission in question over the full bandwidth of the channel.

3.1.2 Spurious Emissions

FCC §22.917

(a) Out of band emissions. The power of any emission outside of the authorized operating frequency ranges must be attenuated below the transmitting power (P) by a factor of at least $43 + 10 \log(P)$ dB.

(b) Measurement procedure. Compliance with these rules is based on the use of measurement instrumentation employing a reference bandwidth as follows:

- (1) In the spectrum below 1 GHz, instrumentation should employ a reference bandwidth of 100 kHz or greater. In the 1 MHz bands immediately outside and adjacent to the frequency block, a resolution bandwidth of at least one percent of the emission bandwidth of the fundamental emission of the transmitter may be employed. A narrower resolution bandwidth is permitted in all cases to improve measurement accuracy, provided that the measured power is integrated over the full required reference bandwidth (i.e., 100 kHz or 1 percent of emission bandwidth, as specified). The emission bandwidth is defined as the width of the signal between two points, one below the carrier center frequency and one above the carrier center frequency, outside of which all emissions are attenuated at least 26 dB below the transmitter power.
- (2) In the spectrum above 1 GHz, instrumentation should employ a reference bandwidth of 1 MHz

3.1.3 Frequency stability

FCC §22.355

Except as otherwise provided in this part, the carrier frequency of each transmitter in the Public Mobile Services must be maintained within the tolerances given in Table C-1 of this section.

Table C-1 - Frequency Tolerance for Transmitters in the Public Mobile Services

Frequency range (MHz)	Base, fixed (ppm)	Mobile >3 watts (ppm)	Mobile \leq3 watts (ppm)
25 to 50	20	20	50
50 to 450	5	5	50
450 to 512	2.5	5	5
821 to 896	1.5	2.5	2.5
928 to 929	5	n/a	n/a
929 to 960	1.5	n/a	n/a
2110 to 2220	10	n/a	n/a

3.2 Applicable Standard For Part 24 Subpart E:

3.2.1 RF Output Power

FCC §24.232

(c) Mobile and portable stations are limited to 2 watts EIRP and the equipment must employ a means for limiting power to the minimum necessary for successful communications.

(d) Power measurements for transmissions by stations authorized under this section may be made either in accordance with a Commission-approved average power technique or in compliance with paragraph (e) of this section. In both instances, equipment employed must be authorized in accordance with the provisions of § 24.51. In measuring transmissions in this band using an average power technique, the peak-to-average ratio (PAR) of the transmission may not exceed 13 dB.

3.2.2 Spurious Emissions

FCC §24.238

The rules in this section govern the spectral characteristics of emissions in the Broadband Personal Communications Service.

(a) Out of band emissions. The power of any emission outside of the authorized operating frequency ranges must be attenuated below the transmitting power (P) by a factor of at least $43 + 10 \log(P)$ dB.

(b) Measurement procedure. Compliance with these rules is based on the use of measurement instrumentation employing a resolution bandwidth of 1 MHz or greater. However, in the 1 MHz bands immediately outside and adjacent to the frequency block a resolution bandwidth of at least one percent of the emission bandwidth of the fundamental emission of the transmitter may be employed. A narrower resolution bandwidth is permitted in all cases to improve measurement accuracy provided the measured power is integrated over the full required measurement bandwidth (i.e. 1 MHz or 1 percent of emission bandwidth, as specified). The emission bandwidth is defined as the width of the signal between two points, one below the carrier center frequency and one above the carrier center frequency, outside of which all emissions are attenuated at least 26 dB below the transmitter power.

(c) Alternative out of band emission limit. Licensees in this service may establish an alternative out of band emission limit to be used at specified band edge(s) in specified geographical areas, in lieu of that set forth in this section, pursuant to a private contractual arrangement of all affected licensees and applicants. In this event, each party to such contract shall maintain a copy of the contract in their station files and disclose it to prospective assignees or transferees and, upon request, to the FCC.

(d) Interference caused by out of band emissions. If any emission from a transmitter operating in this service results in interference to users of another radio service, the FCC may require a greater attenuation of that emission than specified in this section.

3.2.3 Frequency stability

FCC §24.235

The frequency stability shall be sufficient to ensure that the fundamental emission stays within the authorized frequency block.

3.3 Applicable Standard For Part 27:

3.3.1 RF Output Power

FCC §27.50

(a)(3) *Mobile and portable stations.*

(i) For mobile and portable stations transmitting in the 2305-2315 MHz band or the 2350-2360 MHz band, the average EIRP must not exceed 50 milliwatts within any 1 megahertz of authorized bandwidth, *except that* for mobile and portable stations compliant with 3GPP LTE standards or another advanced mobile broadband protocol that avoids concentrating energy at the edge of the operating band the average EIRP must not exceed 250 milliwatts within any 5 megahertz of authorized bandwidth but may exceed 50 milliwatts within any 1 megahertz of authorized bandwidth. For mobile and portable stations using time division duplexing (TDD) technology, the duty cycle must not exceed 38 percent in the 2305-2315 MHz and 2350-2360 MHz bands. Mobile and portable stations using FDD technology are restricted to transmitting in the 2305-2315 MHz band. Power averaging shall not include intervals in which the transmitter is off.

(ii) Mobile and portable stations are not permitted to transmit in the 2315-2320 MHz and 2345-2350 MHz bands.

(iii) *Automatic transmit power control.* Mobile and portable stations transmitting in the 2305-2315 MHz band or in the 2350-2360 MHz band must employ automatic transmit power control when operating so the stations operate with the minimum power necessary for successful communications.

(iv) *Prohibition on external vehicle-mounted antennas.* The use of external vehicle-mounted antennas for mobile and portable stations transmitting in the 2305-2315 MHz band or the 2350-2360 MHz band is prohibited.

(b)(10) Portable stations (hand-held devices) transmitting in the 746-757 MHz, 776-788 MHz, and 805-806 MHz bands are limited to 3 watts ERP.

(c)(10) Portable stations (hand-held devices) in the 600 MHz uplink band and the 698-746 MHz band, and fixed and mobile stations in the 600 MHz uplink band are limited to 3 watts ERP.

(d)(4) Fixed, mobile, and portable (hand-held) stations operating in the 1710-1755 MHz band and mobile and portable stations operating in the 1695-1710 MHz and 1755-1780 MHz bands are limited to 1 watt EIRP. Fixed stations operating in the 1710-1755 MHz band are limited to a maximum antenna height of 10 meters above ground. Mobile and portable stations operating in these bands must employ a means for limiting power to the minimum necessary for successful communications.

(h) The following power limits shall apply in the BRS and EBS:

(2) Mobile and other user stations. Mobile stations are limited to 2.0 watts EIRP. All user stations are limited to 2.0 watts transmitter output power.

(j) The following power requirements apply to stations transmitting in the 3700 – 3980 MHz band:

(3) Mobile and portable stations are limited to 1 Watt EIRP. Mobile and portable stations operating in these bands must employ a means for limiting power to the minimum necessary for successful communications.

(k) The following power requirements apply to stations transmitting in the 3450 – 3550 MHz band:

(3) Mobile devices are limited to 1 Watt (30 dBm) EIRP. Mobile devices operating in these bands must employ a means for limiting power to the minimum necessary for successful communications.

3.3.2 Spurious Emissions

FCC §27.53

(a) For operations in the 2305-2320 MHz band and the 2345-2360 MHz band, the power of any emission outside a licensee's frequency band(s) of operation shall be attenuated below the transmitter power P (with averaging performed only during periods of transmission) within the licensed band(s) of operation, in watts, by the following amounts:

(4) For mobile and portable stations operating in the 2305-2315 MHz and 2350-2360 MHz bands:

(i) By a factor of not less than: $43 + 10 \log (P)$ dB on all frequencies between 2305 and 2320 MHz and on all frequencies between 2345 and 2360 MHz that are outside the licensed band(s) of operation, not less than $55 + 10 \log (P)$ dB on all frequencies between 2320 and 2324 MHz and on all frequencies between 2341 and 2345 MHz, not less than $61 + 10 \log (P)$ dB on all frequencies between 2324 and 2328 MHz and on all frequencies between 2337 and 2341 MHz, and not less than $67 + 10 \log (P)$ dB on all frequencies between 2328 and 2337 MHz;

(ii) By a factor of not less than $43 + 10 \log (P)$ dB on all frequencies between 2300 and 2305 MHz, $55 + 10 \log (P)$ dB on all frequencies between 2296 and 2300 MHz, $61 + 10 \log (P)$ dB on all frequencies between 2292 and 2296 MHz, $67 + 10 \log (P)$ dB on all frequencies between 2288 and 2292 MHz, and $70 + 10 \log (P)$ dB below 2288 MHz;

(iii) By a factor of not less than $43 + 10 \log (P)$ dB on all frequencies between 2360 and 2365 MHz, and not less than $70 + 10 \log (P)$ dB above 2365 MHz.

(c) For operations in the 746-758 MHz band and the 776-788 MHz band, the power of any emission outside the licensee's frequency band(s) of operation shall be attenuated below the transmitter power (P) within the licensed band(s) of operation, measured in watts, in accordance with the following:

(1) On any frequency outside the 746-758 MHz band, the power of any emission shall be attenuated outside the band below the transmitter power (P) by at least $43 + 10 \log (P)$ dB;

(2) On any frequency outside the 776-788 MHz band, the power of any emission shall be attenuated outside the band below the transmitter power (P) by at least $43 + 10 \log (P)$ dB;

(3) On all frequencies between 763-775 MHz and 793-805 MHz, by a factor not less than $76 + 10 \log (P)$ dB in a 6.25 kHz band segment, for base and fixed stations;

(4) On all frequencies between 763-775 MHz and 793-805 MHz, by a factor not less than $65 + 10 \log (P)$ dB in a 6.25 kHz band segment, for mobile and portable stations;

(5) Compliance with the provisions of paragraphs (c)(1) and (c)(2) of this section is based on the use of measurement instrumentation employing a resolution bandwidth of 100 kHz or greater. However, in the 100 kHz bands immediately outside and adjacent to the frequency block, a resolution bandwidth of at least 30 kHz may be employed;

(6) Compliance with the provisions of paragraphs (c)(3) and (c)(4) of this section is based on the use of measurement instrumentation such that the reading taken with any resolution bandwidth setting should be adjusted to indicate spectral energy in a 6.25 kHz segment.

(f) For operations in the 746-758 MHz, 775-788 MHz, and 805-806 MHz bands, emissions in the band 1559-1610 MHz shall be limited to - 70 dBW/MHz equivalent isotropically radiated power (EIRP) for wideband signals, and - 80 dBW EIRP for discrete emissions of less than 700 Hz bandwidth. For the purpose of equipment authorization, a transmitter shall be tested with an antenna that is representative of the type that will be used with the equipment in normal operation.

(g) For operations in the 600 MHz band and the 698-746 MHz band, the power of any emission outside a licensee's frequency band(s) of operation shall be attenuated below the transmitter power (P) within the licensed band(s) of operation, measured in watts, by at least $43 + 10 \log (P)$ dB. Compliance with this provision is based on the use of measurement instrumentation employing a resolution bandwidth of 100 kilohertz or greater. However, in the 100 kilohertz bands immediately outside and adjacent to a licensee's frequency block, a resolution bandwidth of at least 30 kHz may be employed.

(l) 3.7 GHz Service. The following emission limits apply to stations transmitting in the 3700 – 3980 MHz band:

(2) For mobile operations in the 3700 – 3980 MHz band, the conducted power of any emission outside the licensee's authorized bandwidth shall not exceed - 13 dBm/MHz. Compliance with this paragraph (l)(2) is based on the use of measurement instrumentation employing a resolution bandwidth of 1 megahertz or greater. However, in the 1 megahertz bands immediately outside and adjacent to the licensee's frequency block, the minimum resolution bandwidth for the measurement shall be either one percent of the emission bandwidth of the fundamental emission of the transmitter or 350 kHz. In the bands between 1 and 5 MHz removed from the licensee's frequency block, the minimum resolution bandwidth for the measurement shall be 500 kHz. The emission bandwidth is defined as the width of the signal between two points, one below the carrier center frequency and one above the carrier center frequency, outside of which all emissions are attenuated at least 26 dB below the transmitter power.

(h) AWS emission limits

(1) **General protection levels.** Except as otherwise specified below, for operations in the 1695-1710 MHz, 1710-1755 MHz, 1755-1780 MHz, 1915-1920 MHz, 1995-2000 MHz, 2000-2020 MHz, 2110-2155 MHz, 2155-2180 MHz, and 2180-2200 bands, the power of any emission outside a licensee's frequency block shall be attenuated below the transmitter power (P) in watts by at least $43 + 10 \log_{10} (P)$ dB.

(m) For BRS and EBS stations, the power of any emissions outside the licensee's frequency bands of operation shall be attenuated below the transmitter power (P) measured in watts in accordance with the standards below. If a licensee has multiple contiguous channels, out-of-band emissions shall be measured from the upper and lower edges of the contiguous channels.

(4) For mobile digital stations, the attenuation factor shall be not less than $40 + 10 \log (P)$ dB on all frequencies between the channel edge and 5 megahertz from the channel edge, $43 + 10 \log (P)$ dB on all frequencies between 5 megahertz and X megahertz from the channel edge, and $55 + 10 \log (P)$ dB on all frequencies more than X megahertz from the channel edge, where X is the greater of 6 megahertz or the actual emission bandwidth as defined in paragraph (m)(6) of this section. In addition, the attenuation factor shall not be less than $43 + 10 \log (P)$ dB on all frequencies between 2490.5 MHz and 2496 MHz and $55 + 10 \log (P)$ dB at or below 2490.5 MHz. Mobile Satellite Service licensees operating on frequencies below 2495 MHz may also submit a documented interference complaint against BRS licensees operating on channel BRS Channel 1 on the same terms and conditions as adjacent channel BRS or EBS licensees.

(n) 3.45 GHz Service. The following emission limits apply to stations transmitting in the 3450 – 3550 MHz band:

(2) For mobile operations in the 3450 – 3550 MHz band, the conducted power of any emission outside the licensee's authorized bandwidth shall not exceed - 13 dBm/MHz. Compliance with this paragraph (n)(2) is based on the use of measurement instrumentation employing a resolution bandwidth of 1 megahertz or greater. However, in the 1 megahertz bands immediately outside and adjacent to the licensee's frequency block, a resolution bandwidth of at least one percent of the emission bandwidth of the fundamental emission of the transmitter may be employed, but limited to a maximum of 200 kHz. In the bands between 1 and 5 MHz removed from the licensee's frequency block, the minimum resolution bandwidth for the measurement shall be 500 kHz. The emission bandwidth is defined as the width of the signal between two points, one below the carrier center frequency and one above the carrier center frequency, outside of which all emissions are attenuated at least 26 dB below the transmitter power.

3.3.3 Frequency stability

FCC §27.54

The frequency stability shall be sufficient to ensure that the fundamental emissions stay within the authorized bands of operation.

3.4 Test Method:

3.4.1 Transmitter output power, e.r.p. and e.i.r.p

According to CFR Part 2.1046, ANSI C63.26-2015 Section 5.2.5.5 and KDB 971168 D01 Power Meas License Digital Systems v03r01:

The relevant equation for determining the ERP or EIRP from the conducted RF output power measured using the guidance provided above is:

$$\text{ERP or EIRP} = P_{\text{Meas}} + G_T - L_C$$

where:

ERP or EIRP = effective radiated power or equivalent isotropically radiated power, respectively (expressed in the same units as P_{Meas} , typically dBW or dBm);

P_{Meas} = measured transmitter output power or PSD, in dBm or dBW;

G_T = gain of the transmitting antenna, in dBd (ERP) or dBi (EIRP);

L_C = signal attenuation in the connecting cable between the transmitter and antenna, in dB.

Test Setup Block:

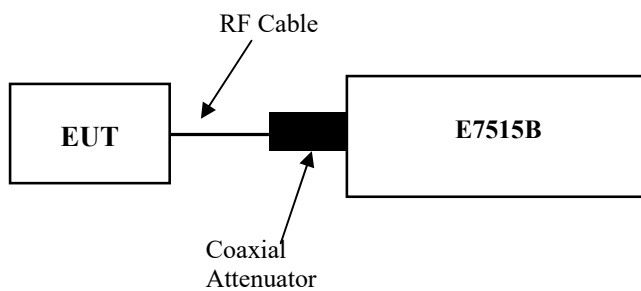

Note: The Insertion loss of the RF cable and coaxial Attenuator was offset into the Reading of E7515B.

3.4.2 Occupied Bandwidth

According to ANSI C63.26-2015 Section 5.4.4

The OBW is the frequency bandwidth such that, below its lower and above its upper frequency limits, the mean powers are each equal to 0.5% of the total mean power of the given emission.

The following procedure shall be used for measuring (99%) power bandwidth:

a) The spectrum analyzer center frequency is set to the nominal EUT channel center frequency. The frequency span for the spectrum analyzer shall be set wide enough to capture all modulation products including the emission skirts (typically a span of $1.5 \times \text{OBW}$ is sufficient).

b) The nominal IF filter 3 dB bandwidth (RBW) shall be in the range of 1% to 5% of the anticipated OBW, and the VBW shall be set $\geq 3 \times \text{RBW}$.

c) Set the reference level of the instrument as required to prevent the signal amplitude from exceeding the maximum spectrum analyzer input mixer level for linear operation. See guidance provided in 4.2.3.
NOTE—Step a), step b), and step c) may require iteration to adjust within the specified tolerances.

d) Set the detection mode to peak, and the trace mode to max-hold.

e) If the instrument does not have a 99% OBW function, recover the trace data points and sum directly in linear power terms. Place the recovered amplitude data points, beginning at the lowest frequency, in a running sum until 0.5% of the total is reached. Record that frequency as the lower OBW frequency. Repeat the process until 99.5% of the total is reached and record that frequency as the upper OBW frequency. The 99% power OBW can be determined by computing the difference these two frequencies.

f) The OBW shall be reported and plot(s) of the measuring instrument display shall be provided with the test report. The frequency and amplitude axis and scale shall be clearly labeled. Tabular data can be reported in addition to the plot(s).

Test Setup Block:

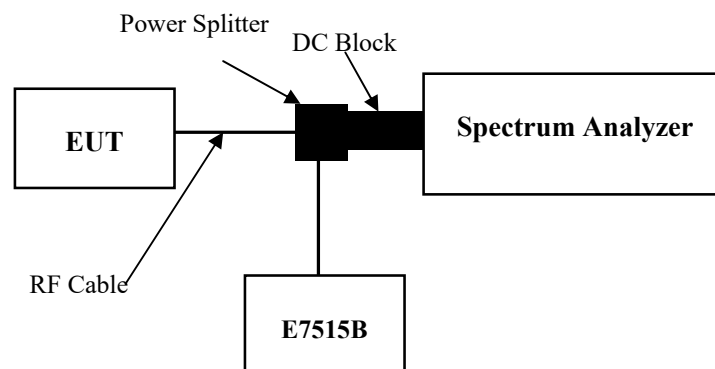

3.4.3 Transmitter unwanted emissions-at antenna terminals

According to ANSI C63.26-2015 Section 5.7.4, KDB 971168 D01 Power Meas License Digital Systems v03r01:

the applicable rule part specifies the reference bandwidth for measuring unwanted emission levels (typically, 100 kHz if the authorized frequency band/block is at or below 1 GHz and 1 MHz if the authorized frequency band/block is above 1 GHz),8 effectively depicting the unwanted emission limit in terms of a power spectral density. In those cases where no reference bandwidth is explicitly specified, the values in the preceding sentence should be used.

Test Setup Block:

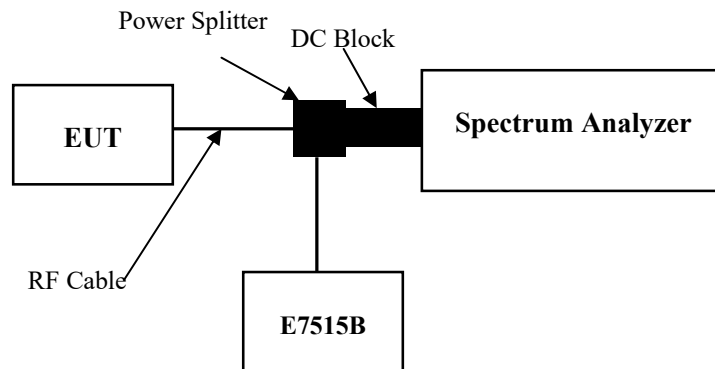

Note: The Insertion loss of the RF cable and coaxial Attenuator was offset into the Spectrum Analyzer.

3.4.4 Transmitter unwanted emissions-Out of band emission

According to ANSI C63.26-2015 Section 5.7.3, KDB 971168 D01 Power Meas License Digital Systems v03r01:

Typically, a measurement (resolution) bandwidth smaller than the reference bandwidth is allowed for measurements within a specified frequency range at the edge of the authorized frequency block/band (e.g., within the first Y MHz outside of the authorized frequency band/block, where the value of Y is specified in the relevant rule part). Some FCC out-of-band emission rules permit the use of a narrower RBW (typically limited to a minimum RBW of 1 % of the OBW) for measuring the out-of-band emissions without a requirement to integrate the result over the full reference bandwidth. Beyond the specified frequency range in which this relaxation of the uniform reference bandwidth is permitted, it typically is also acceptable to use a narrower RBW (again limited to a minimum of 1 % of OBW) to increase accuracy, but the measurement result must subsequently be integrated over the full reference bandwidth.

Test Setup Block:

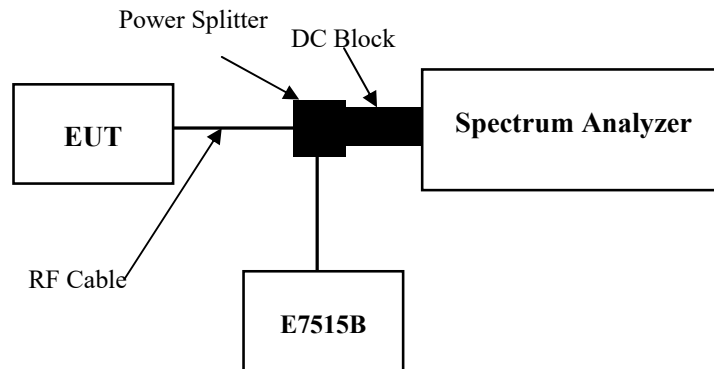

Note: The Insertion loss of the RF cable and coaxial Attenuator was offset into the Spectrum Analyzer.

3.4.5 Frequency stability

According to ANSI C63.26-2015 Section 5.6, KDB 971168 D01 Power Meas License Digital Systems v03r01:

Frequency stability is a measure of the frequency drift due to temperature and supply voltage variations, with reference to the frequency measured at +20 °C and rated supply voltage.

The operating carrier frequency shall be set up in accordance with the manufacturer's published operation and instruction manual prior to the commencement of these tests. No adjustment of any frequency determining circuit element shall be made subsequent to this initial set-up. Frequency stability is tested:

- a) At 10 °C intervals of temperatures between –30 °C and +50 °C at the manufacturer's rated supply voltage, and
- b) At +20 °C temperature and ±15% supply voltage variations. If a product is specified to operate over a range of input voltage then the –15% variation is applied to the lowermost voltage and the +15% is applied to the uppermost voltage.

During the test all necessary settings, adjustments and control of the EUT have to be performed without disturbing the test environment, i.e., without opening the environmental chamber. The frequency stabilities can be maintained to a lesser temperature range provided that the transmitter is automatically inhibited from operating outside the lesser temperature range. For handheld equipment that is only capable of operating from internal batteries and the supply voltage cannot be varied, the frequency stability tests shall be performed at the nominal battery voltage and the battery end point voltage specified by the manufacturer. An external supply voltage can be used and set at the internal battery nominal voltage, and again at the battery operating end point voltage which shall be specified by the equipment manufacturer.

If an unmodulated carrier is not available, the mean frequency of a modulated carrier can be obtained by using a frequency counter with gating time set to an appropriately large multiple of bit periods (gating time depending on the required accuracy). Full details on the choice of values shall be included in the test report.

Test Setup Block:

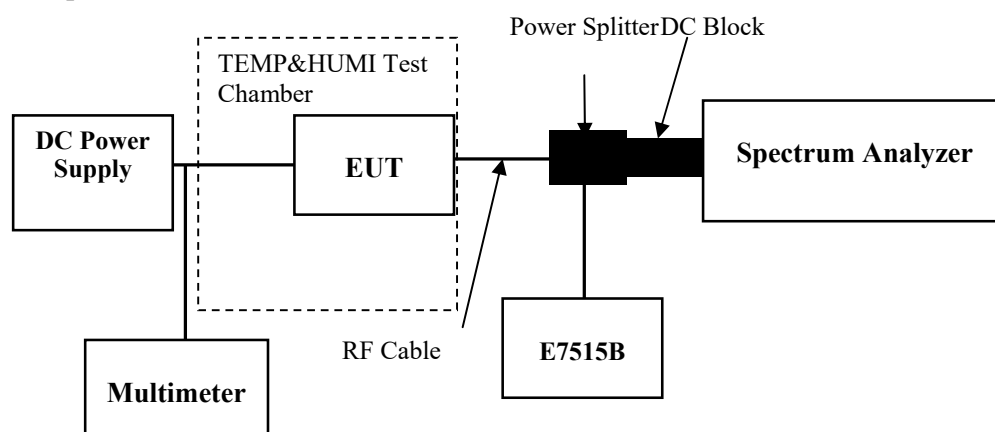

3.4.6 Transmitter unwanted emissions- Radiated Spurious emissions

According to ANSI C63.26-2015 Section 5.5.3:

Test setup:

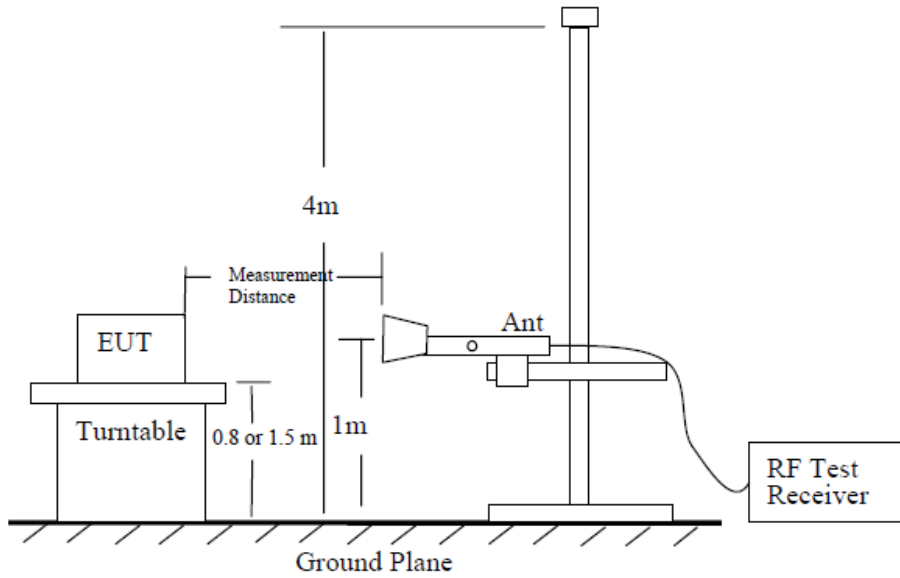

Figure 6—Test site-up for radiated ERP and/or EIRP measurements

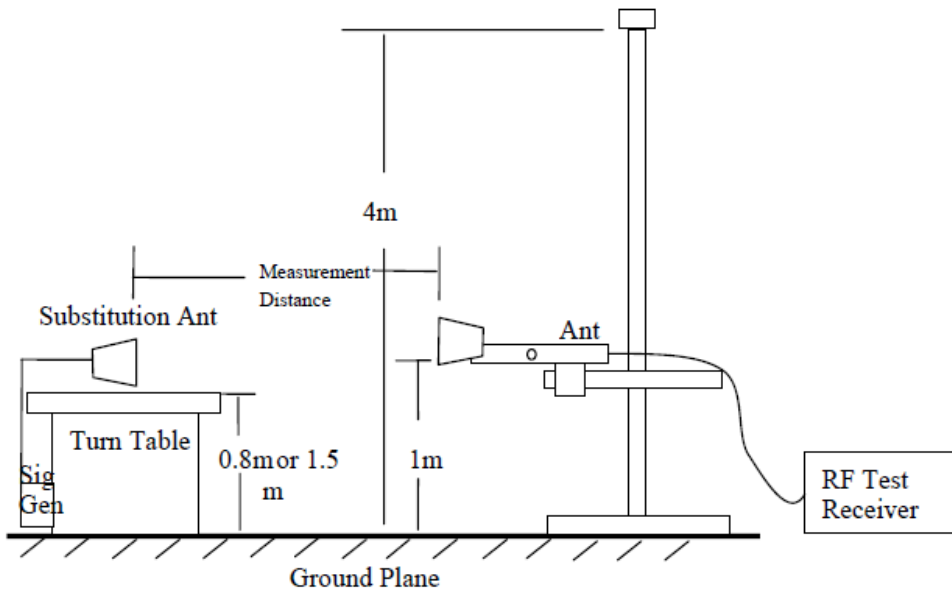

Figure 7—Substitution method set-up for radiated emission

Test Procedure:

- a) Place the EUT in the center of the turntable. The EUT shall be configured to transmit into the standard non-radiating load (for measuring radiated spurious emissions), connected with cables of minimal length unless specified otherwise. If the EUT uses an adjustable antenna, the antenna shall be positioned to the length that produces the worst case emission at the fundamental operating frequency.
- b) Each emission under consideration shall be evaluated:
 - 1) Raise and lower the measurement antenna in accordance 5.5.2, as necessary to enable detection of the maximum emission amplitude relative to measurement antenna height.
 - 2) Rotate the EUT through 360° to determine the maximum emission level relative to the axial position.
 - 3) Return the turntable to the azimuth where the highest emission amplitude level was observed.
 - 4) Vary the measurement antenna height again through 1 m to 4 m again to find the height associated with the maximum emission amplitude.
 - 5) Record the measured emission amplitude level and frequency using the appropriate RBW.
- c) Repeat step b) for each emission frequency with the measurement antenna oriented in both the horizontal and vertical polarizations to determine the orientation that gives the maximum emissions amplitude.
- d) Set-up the substitution measurement with the reference point of the substitution antenna located as near as possible to where the center of the EUT radiating element was located during the initial EUT measurement.
- e) Maintain the previous measurement instrument settings and test set-up, with the exception that the EUT is removed and replaced by the substitution antenna.
- f) Connect a signal generator to the substitution antenna; locate the signal generator so as to minimize any potential influences on the measurement results. Set the signal generator to the frequency where emissions are detected, and set an output power level such that the radiated signal can be detected by the measurement instrument, with sufficient dynamic range relative to the noise floor.
- g) For each emission that was detected and measured in the initial test [i.e., in step b) and step c)]:
 - 1) Vary the measurement antenna height between 1 m to 4 m to maximize the received (measured) signal amplitude.
 - 2) Adjust the signal generator output power level until the amplitude detected by the measurement instrument equals the amplitude level of the emission previously measured directly in step b) and step c).
 - 3) Record the output power level of the signal generator when equivalence is achieved in step 2).
- h) Repeat step e) through step g) with the measurement antenna oriented in the opposite polarization.
- i) Calculate the emission power in dBm referenced to a half-wave dipole using the following equation:

$$P_e = P_s(\text{dBm}) - \text{cable loss (dB)} + \text{antenna gain (dBd)}$$
 where
 - P_e = equivalent emission power in dBm
 - P_s = source (signal generator) power in dBm
 NOTE—dBd refers to the measured antenna gain in decibels relative to a half-wave dipole.
- j) Correct the antenna gain of the substitution antenna if necessary to reference the emission power to a half-wave dipole. When using measurement antennas with the gain specified in dBi, the equivalent dipole-referenced gain can be determined from: $\text{gain (dBd)} = \text{gain (dBi)} - 2.15 \text{ dB}$. If necessary, the antenna gain can be calculated from calibrated antenna factor information
- k) Provide the complete measurement results as a part of the test report.

4. Test DATA AND RESULTS

4.1 Antenna Port Test Data and Results:

Serial Number:	2DU1-1	Test Date:	2023/11/18-2024/01/17
Test Site:	RF	Test Mode:	TX
Tester:	One Luo	Test Result:	Pass

Environmental Conditions:

Temperature: (°C)	20.2~26.4	Relative Humidity: (%)	32~61	ATM Pressure: (kPa)	100.8~102.6
----------------------	-----------	------------------------------	-------	------------------------	-------------

Test Equipment List and Details:

Manufacturer	Description	Model	Serial Number	Calibration Date	Calibration Due Date
R&S	Spectrum Analyzer	FSV40	101474	2023/3/31	2024/3/30
BACL	TEMP&HUMI Test Chamber	BTH-150-40	30174	2023/3/31	2024/3/30
UNI-T	Multimeter	UT39A+	C210582554	2023/9/28	2024/9/27
ZHAOXIN	DC Power Supply	RXN-6010D	21R6010D0912386	N/A	N/A
Agilent	Power divider	11636B	56199	Each time	N/A
JD	RF Regulatory Test System	5G NR Test Software	V1.2.04	N/A	N/A
Decentest	Multiplex Switch Test Control Set	DT7200SCU	DQ76345D	2023/11/1	2024/10/31
Decentest	Filter Switch Unit	DT7200FSU	DQ76345C	N/A	N/A
Keysight	UXM 5G Wireless Test Platform	E7515B	MY58120285	2023/11/16	2024/11/15

* Statement of Traceability: China Certification ICT Co., Ltd (Dongguan) attests that all calibrations have been performed, traceable to National Primary Standards and International System of Units (SI).

Test Data

Test Result: Compliant. The test data please refer to the plots in the Appendix A~L.

4.2 Radiated Spurious Emissions

Serial Number:	2BD2-5	Test Date:	2024/1/18
Test Site:	966-2,966-1	Test Mode:	Transmitting
Tester:	Carl Xue, Mack Huang	Test Result:	Pass

Environmental Conditions:

Temperature: (°C)	25.4~25.8	Relative Humidity: (%)	40~54	ATM Pressure: (kPa)	101.8
----------------------	-----------	---------------------------	-------	---------------------------	-------

Test Equipment List and Details:

Manufacturer	Description	Model	Serial Number	Calibration Date	Calibration Due Date
Sunol Sciences	Antenna	JB6	A082520-5	2023/12/1	2026/11/30
R&S	EMI Test Receiver	ESR3	102724	2023/3/31	2024/3/30
TIMES MICROWAVE	Coaxial Cable	LMR-600-UltraFlex	C-0470-02	2023/7/16	2024/7/15
TIMES MICROWAVE	Coaxial Cable	LMR-600-UltraFlex	C-0780-01	2023/7/16	2024/7/15
Sonoma	Amplifier	310N	186165	2023/7/16	2024/7/15
EMCO	Adjustable Dipole Antenna	3121C	9109-756	N/A	N/A
MICRO-COAX	Coaxial Cable	UFA210B-0-0720-300300	99G1448	2023/7/16	2024/7/15
Agilent	Signal Generator	E8247C	MY43321352	2023/11/17	2024/11/16
AH	Double Ridge Guide Horn Antenna	SAS-571	1394	2023/2/22	2026/2/21
R&S	Spectrum Analyzer	FSV40	101591	2023/3/31	2024/3/30
MICRO-COAX	Coaxial Cable	UFA210A-1-1200-70U300	217423-008	2023/8/6	2024/8/5
MICRO-COAX	Coaxial Cable	UFA210A-1-2362-300300	235780-001	2023/8/6	2024/8/5
Mini	Pre-amplifier	ZVA-183-S+	5969001149	2023/11/8	2024/11/7
AH	Double Ridge Guide Horn Antenna	SAS-571	1396	2021/10/18	2024/10/17
MICRO-COAX	Coaxial Cable	UFA210B-0-0720-300300	99G1448	2023/7/16	2024/7/15
PASTERNAK	Horn Antenna	PE9852/2F-20	112002	2021/2/5	2024/2/4
PASTERNAK	Horn Antenna	PE9852/2F-20	112001	2021/2/5	2024/2/4
Quinstar	Preamplifier	QLW-18405536-JO	15964001005	2023/9/15	2024/9/14
PASTERNAK	Horn Antenna	PE9850/2F-20	072001	2021/2/5	2024/2/4
PASTERNAK	Horn Antenna	PE9850/2F-20	072002	2021/2/5	2024/2/4
MICRO-COAX	Coaxial Cable	UFB142A-1-2362-200200	235772-001	2023/8/6	2024/8/5

* **Statement of Traceability:** China Certification ICT Co., Ltd (Dongguan) attests that all calibrations have been performed, traceable to National Primary Standards and International System of Units (SI).

Test Data:

Please refer to the below tables.

Note: The device can be mounted in multiple orientations, pretest was performed with X,Y, Z Axis according to C63.26 figure 5, the worst orientation was photographed and it's data was recorded.

5G NR n5:

Frequency (MHz)	Polar (H/V)	Receiver Reading (dBμV)	Substituted Method			Absolute Level (dBm)	Limit (dBm)	Margin (dB)
			Substituted Level (dBm)	Antenna Gain (dBd/dBi)	Cable Loss (dB)			
5MHz QPSK, Frequency:			826.5	MHz				
489.02	H	28.74	-78.38	0.00	0.44	-78.82	-13.00	65.82
187.75	V	29.16	-80.43	0.00	0.26	-80.69	-13.00	67.69
1653.000	H	40.53	-63.80	8.68	0.81	-55.93	-13.00	42.93
1653.000	V	39.18	-65.23	8.68	0.81	-57.36	-13.00	44.36
2479.500	H	40.46	-60.30	9.39	1.01	-51.92	-13.00	38.92
2479.500	V	43.18	-57.55	9.39	1.01	-49.17	-13.00	36.17
5MHz QPSK, Frequency:			836.5	MHz				
184.67	H	28.61	-83.97	0.00	0.25	-84.22	-13.00	71.22
40.19	V	28.73	-61.34	-26.15	0.11	-87.60	-13.00	74.60
1673.000	H	36.78	-67.53	8.71	0.85	-59.67	-13.00	46.67
1673.000	V	36.89	-67.52	8.71	0.85	-59.66	-13.00	46.66
2509.500	H	42.52	-58.09	9.42	1.01	-49.68	-13.00	36.68
2509.500	V	43.64	-56.98	9.42	1.01	-48.57	-13.00	35.57
5MHz QPSK, Frequency:			846.5	MHz				
238.48	H	28.70	-83.43	0.00	0.29	-83.72	-13.00	70.72
59.50	V	28.69	-77.08	-10.53	0.14	-87.75	-13.00	74.75
1693.000	H	37.59	-66.71	8.73	0.89	-58.87	-13.00	45.87
1693.000	V	38.87	-65.55	8.73	0.89	-57.71	-13.00	44.71
2539.500	H	44.46	-55.92	9.46	1.01	-47.47	-13.00	34.47
2539.500	V	44.30	-56.05	9.46	1.01	-47.60	-13.00	34.60

5G NR n7:

Frequency (MHz)	Polar (H/V)	Receiver Reading (dBμV)	Substituted Method			Absolute Level (dBm)	Limit (dBm)	Margin (dB)
			Substituted Level (dBm)	Antenna Gain (dBd/dBi)	Cable Loss (dB)			
5MHz QPSK, Frequency: 2502.5 MHz								
129.01	H	29.25	-82.93	0.00	0.21	-83.14	-25.00	58.14
295.14	V	28.88	-80.14	0.00	0.33	-80.47	-25.00	55.47
5005.000	H	37.92	-55.04	11.20	1.47	-45.31	-25.00	20.31
5005.000	V	37.15	-55.67	11.20	1.47	-45.94	-25.00	20.94
7507.500	H	40.81	-48.98	10.90	1.95	-40.03	-25.00	15.03
7507.500	V	41.50	-48.79	10.90	1.95	-39.84	-25.00	14.84
5MHz QPSK, Frequency: 2535 MHz								
87.75	H	28.76	-83.54	0.00	0.17	-83.71	-25.00	58.71
130.94	V	29.15	-77.82	0.00	0.21	-78.03	-25.00	53.03
5070.000	H	37.42	-55.77	11.24	1.47	-46.00	-25.00	21.00
5070.000	V	37.54	-55.55	11.24	1.47	-45.78	-25.00	20.78
7605.000	H	40.90	-48.57	10.88	2.01	-39.70	-25.00	14.70
7605.000	V	40.87	-49.32	10.88	2.01	-40.45	-25.00	15.45
5MHz QPSK, Frequency: 2567.5 MHz								
244.93	H	28.99	-83.01	0.00	0.30	-83.31	-25.00	58.31
85.40	V	28.79	-80.20	0.00	0.17	-80.37	-25.00	55.37
5135.000	H	43.24	-50.36	11.28	1.47	-40.55	-25.00	15.55
5135.000	V	41.81	-51.68	11.28	1.47	-41.87	-25.00	16.87
7702.500	H	40.17	-49.35	10.86	1.97	-40.46	-25.00	15.46
7702.500	V	40.32	-49.86	10.86	1.97	-40.97	-25.00	15.97

5G NR n12:

Frequency (MHz)	Polar (H/V)	Receiver Reading (dBμV)	Substituted Method			Absolute Level (dBm)	Limit (dBm)	Margin (dB)
			Substituted Level (dBm)	Antenna Gain (dBd/dBi)	Cable Loss (dB)			
5MHz QPSK, Frequency: 701.5 MHz								
47.16	H	28.91	-67.08	-17.68	0.12	-84.88	-13.00	71.88
136.41	V	28.64	-78.94	0.00	0.22	-79.16	-13.00	66.16
1403.000	H	37.66	-66.04	8.23	0.71	-58.52	-13.00	45.52
1403.000	V	36.90	-66.84	8.23	0.71	-59.32	-13.00	46.32
2104.500	H	40.55	-61.35	9.16	0.91	-53.10	-13.00	40.10
2104.500	V	38.88	-62.98	9.16	0.91	-54.73	-13.00	41.73
2806.000	H	36.31	-63.59	9.89	1.04	-54.74	-13.00	41.74
2806.000	V	35.50	-64.29	9.89	1.04	-55.44	-13.00	42.44
5MHz QPSK, Frequency: 707.5 MHz								
72.81	H	28.52	-76.95	-3.60	0.16	-80.71	-13.00	67.71
97.79	V	28.92	-78.62	0.00	0.19	-78.81	-13.00	65.81
1415.000	H	37.89	-65.78	8.26	0.72	-58.24	-13.00	45.24
1415.000	V	36.47	-67.25	8.26	0.72	-59.71	-13.00	46.71
2122.500	H	39.95	-62.04	9.17	0.92	-53.79	-13.00	40.79
2122.500	V	42.03	-59.94	9.17	0.92	-51.69	-13.00	38.69
2830.000	H	37.96	-61.84	9.93	1.06	-52.97	-13.00	39.97
2830.000	V	37.12	-62.61	9.93	1.06	-53.74	-13.00	40.74
5MHz QPSK, Frequency: 713.5 MHz								
96.03	H	28.83	-83.80	0.00	0.19	-83.99	-13.00	70.99
176.26	V	28.78	-80.73	0.00	0.25	-80.98	-13.00	67.98
1427.000	H	39.49	-64.15	8.30	0.73	-56.58	-13.00	43.58
1427.000	V	36.36	-67.33	8.30	0.73	-59.76	-13.00	46.76
2140.500	H	42.94	-59.13	9.18	0.93	-50.88	-13.00	37.88
2140.500	V	42.47	-59.61	9.18	0.93	-51.36	-13.00	38.36
2854.000	H	37.52	-62.17	9.97	1.07	-53.27	-13.00	40.27
2854.000	V	38.14	-61.54	9.97	1.07	-52.64	-13.00	39.64

5G NR n38:

Frequency (MHz)	Polar (H/V)	Receiver Reading (dBμV)	Substituted Method			Absolute Level (dBm)	Limit (dBm)	Margin (dB)
			Substituted Level (dBm)	Antenna Gain (dBd/dBi)	Cable Loss (dB)			
10MHz QPSK, Frequency: 2575 MHz								
111.07	H	28.65	-83.57	0.00	0.20	-83.77	-25.00	58.77
39.99	V	28.59	-61.22	-26.40	0.11	-87.73	-25.00	62.73
5150.000	H	40.38	-53.35	11.29	1.43	-43.49	-25.00	18.49
5150.000	V	38.44	-55.17	11.29	1.43	-45.31	-25.00	20.31
7725.000	H	40.71	-48.80	10.86	2.00	-39.94	-25.00	14.94
7725.000	V	40.10	-50.01	10.86	2.00	-41.15	-25.00	16.15
10MHz QPSK, Frequency: 2595 MHz								
326.74	H	29.19	-81.13	0.00	0.34	-81.47	-25.00	56.47
169.95	V	28.62	-80.44	0.00	0.24	-80.68	-25.00	55.68
5190.000	H	42.64	-51.43	11.31	1.44	-41.56	-25.00	16.56
5190.000	V	41.18	-52.74	11.31	1.44	-42.87	-25.00	17.87
7785.000	H	39.69	-49.80	10.84	1.99	-40.95	-25.00	15.95
7785.000	V	38.90	-51.02	10.84	1.99	-42.17	-25.00	17.17
10MHz QPSK, Frequency: 2615 MHz								
94.54	H	28.68	-84.05	0.00	0.19	-84.24	-25.00	59.24
237.39	V	28.55	-82.00	0.00	0.29	-82.29	-25.00	57.29
5230.000	H	45.02	-48.91	11.34	1.46	-39.03	-25.00	14.03
5230.000	V	44.50	-49.25	11.34	1.46	-39.37	-25.00	14.37
7845.000	H	40.19	-49.04	10.83	2.02	-40.23	-25.00	15.23
7845.000	V	39.45	-50.17	10.83	2.02	-41.36	-25.00	16.36

5G NR n40_1:

Frequency (MHz)	Polar (H/V)	Receiver Reading (dBμV)	Substituted Method			Absolute Level (dBm)	Limit (dBm)	Margin (dB)
			Substituted Level (dBm)	Antenna Gain (dBd/dBi)	Cable Loss (dB)			
10MHz QPSK, Frequency:			2310	MHz				
429.40	H	29.03	-79.49	0.00	0.40	-79.89	-40.00	39.89
50.77	V	28.66	-72.94	-14.55	0.13	-87.62	-40.00	47.62
4620.000	H	36.83	-58.49	10.74	1.41	-49.16	-40.00	9.16
4620.000	V	36.06	-59.13	10.74	1.41	-49.80	-40.00	9.80
6930.000	H	38.09	-52.91	11.21	1.89	-43.59	-40.00	3.59
6930.000	V	38.14	-52.73	11.21	1.89	-43.41	-40.00	3.41

5G NR n40_2:

Frequency (MHz)	Polar (H/V)	Receiver Reading (dBμV)	Substituted Method			Absolute Level (dBm)	Limit (dBm)	Margin (dB)
			Substituted Level (dBm)	Antenna Gain (dBd/dBi)	Cable Loss (dB)			
10MHz QPSK, Frequency:			2355	MHz				
142.44	H	28.95	-83.26	0.00	0.21	-83.47	-40.00	43.47
77.85	V	28.74	-78.56	-1.08	0.16	-79.80	-40.00	39.80
4710.000	H	36.14	-58.61	10.85	1.41	-49.17	-40.00	9.17
4710.000	V	35.21	-59.55	10.85	1.41	-50.11	-40.00	10.11
7065.000	H	37.20	-52.70	11.16	1.92	-43.46	-40.00	3.46
7065.000	V	37.34	-52.47	11.16	1.92	-43.23	-40.00	3.23

5G NR n41:

Frequency (MHz)	Polar (H/V)	Receiver Reading (dBμV)	Substituted Method			Absolute Level (dBm)	Limit (dBm)	Margin (dB)
			Substituted Level (dBm)	Antenna Gain (dBd/dBi)	Cable Loss (dB)			
10MHz QPSK, Frequency: 2501.01 MHz								
49.70	H	28.93	-71.42	-15.19	0.12	-86.73	-25.00	61.73
163.06	V	28.56	-80.01	0.00	0.24	-80.25	-25.00	55.25
5002.020	H	34.97	-57.98	11.20	1.48	-48.26	-25.00	23.26
5002.020	V	34.98	-57.83	11.20	1.48	-48.11	-25.00	23.11
7503.030	H	38.54	-51.27	10.90	1.94	-42.31	-25.00	17.31
7503.030	V	38.78	-51.52	10.90	1.94	-42.56	-25.00	17.56
10MHz QPSK, Frequency: 2592.99 MHz								
37.42	H	28.82	-51.95	-25.16	0.12	-77.23	-25.00	52.23
92.43	V	28.72	-80.05	0.00	0.18	-80.23	-25.00	55.23
5185.980	H	45.01	-49.02	11.31	1.44	-39.15	-25.00	14.15
5185.980	V	44.43	-49.46	11.31	1.44	-39.59	-25.00	14.59
7778.970	H	40.09	-49.40	10.84	1.99	-40.55	-25.00	15.55
7778.970	V	39.39	-50.55	10.84	1.99	-41.70	-25.00	16.70
10MHz QPSK, Frequency: 2685 MHz								
229.74	H	28.75	-83.55	0.00	0.29	-83.84	-25.00	58.84
66.73	V	28.91	-74.81	-6.73	0.15	-81.69	-25.00	56.69
5370.000	H	47.88	-45.63	11.42	1.48	-35.69	-25.00	10.69
5370.000	V	46.56	-46.92	11.42	1.48	-36.98	-25.00	11.98
8055.000	H	37.46	-50.74	10.81	2.15	-42.08	-25.00	17.08
8055.000	V	38.73	-49.96	10.81	2.15	-41.30	-25.00	16.30

5G NR n66 (30MHz-20GHz):

Frequency (MHz)	Polar (H/V)	Receiver Reading (dBμV)	Substituted Method			Absolute Level (dBm)	Limit (dBm)	Margin (dB)
			Substituted Level (dBm)	Antenna Gain (dBd/dBi)	Cable Loss (dB)			
5MHz QPSK, Frequency:			1712.5	MHz				
90.30	H	28.66	-84.35	0.00	0.18	-84.53	-13.00	71.53
96.28	V	28.63	-79.26	0.00	0.19	-79.45	-13.00	66.45
3425.000	H	37.67	-60.10	10.37	1.17	-50.90	-13.00	37.90
3425.000	V	38.51	-59.23	10.37	1.17	-50.03	-13.00	37.03
5137.500	H	42.05	-51.57	11.28	1.46	-41.75	-13.00	28.75
5137.500	V	39.69	-53.82	11.28	1.46	-44.00	-13.00	31.00
6850.000	H	41.03	-50.37	11.23	1.88	-41.02	-13.00	28.02
6850.000	V	40.04	-51.21	11.23	1.88	-41.86	-13.00	28.86
5MHz QPSK, Frequency:			1745	MHz				
367.92	H	28.89	-80.80	0.00	0.37	-81.17	-13.00	68.17
210.04	V	28.82	-80.82	0.00	0.26	-81.08	-13.00	68.08
3490.000	H	38.34	-59.50	10.40	1.17	-50.27	-13.00	37.27
3490.000	V	38.92	-58.86	10.40	1.17	-49.63	-13.00	36.63
5235.000	H	39.92	-53.98	11.34	1.46	-44.10	-13.00	31.10
5235.000	V	38.25	-55.46	11.34	1.46	-45.58	-13.00	32.58
6980.000	H	39.69	-51.17	11.20	1.90	-41.87	-13.00	28.87
6980.000	V	39.07	-51.64	11.20	1.90	-42.34	-13.00	29.34
5MHz QPSK, Frequency:			1777.5	MHz				
220.61	H	28.92	-83.56	0.00	0.27	-83.83	-13.00	70.83
152.89	V	28.67	-79.55	0.00	0.23	-79.78	-13.00	66.78
3555.000	H	38.07	-59.62	10.46	1.22	-50.38	-13.00	37.38
3555.000	V	37.88	-59.70	10.46	1.22	-50.46	-13.00	37.46
5332.500	H	36.95	-56.52	11.40	1.47	-46.59	-13.00	33.59
5332.500	V	37.10	-56.21	11.40	1.47	-46.28	-13.00	33.28
7110.000	H	36.73	-52.71	11.13	1.92	-43.50	-13.00	30.50
7110.000	V	37.42	-51.97	11.13	1.92	-42.76	-13.00	29.76

5G NR n 77 1:

Frequency (MHz)	Polar (H/V)	Receiver Reading (dBμV)	Substituted Method			Absolute Level (dBm)	Limit (dBm)	Margin (dB)
			Substituted Level (dBm)	Antenna Gain (dBd/dBi)	Cable Loss (dB)			
10MHz QPSK, Frequency: 3455 MHz								
287.87	H	28.51	-82.50	0.00	0.33	-82.83	-13.00	69.83
51.02	V	28.59	-73.13	-14.43	0.13	-87.69	-13.00	74.69
6910.000	H	42.69	-48.37	11.22	1.87	-39.02	-13.00	26.02
6910.000	V	39.82	-51.11	11.22	1.87	-41.76	-13.00	28.76
10365.000	H	44.43	-41.89	11.48	2.49	-32.90	-13.00	19.90
10365.000	V	41.89	-44.52	11.48	2.49	-35.53	-13.00	22.53
10MHz QPSK, Frequency: 3500 MHz								
68.94	H	28.69	-75.10	-5.56	0.15	-80.81	-13.00	67.81
162.11	V	28.54	-79.96	0.00	0.24	-80.20	-13.00	67.20
7000.000	H	43.18	-47.62	11.20	1.89	-38.31	-13.00	25.31
7000.000	V	38.78	-51.87	11.20	1.89	-42.56	-13.00	29.56
10500.000	H	41.91	-44.13	11.40	2.52	-35.25	-13.00	22.25
10500.000	V	38.17	-47.96	11.40	2.52	-39.08	-13.00	26.08
10MHz QPSK, Frequency: 3545 MHz								
190.40	H	28.71	-83.99	0.00	0.26	-84.25	-13.00	71.25
257.42	V	28.94	-81.71	0.00	0.30	-82.01	-13.00	69.01
7090.000	H	51.96	-37.60	11.15	1.90	-28.35	-13.00	15.35
7090.000	V	42.77	-46.71	11.15	1.90	-37.46	-13.00	24.46
10635.000	H	41.09	-44.80	11.40	2.49	-35.89	-13.00	22.89
10635.000	V	39.63	-46.40	11.40	2.49	-37.49	-13.00	24.49

5G NR n 77 2:

Frequency (MHz)	Polar (H/V)	Receiver Reading (dBμV)	Substituted Method			Absolute Level (dBm)	Limit (dBm)	Margin (dB)
			Substituted Level (dBm)	Antenna Gain (dBd/dBi)	Cable Loss (dB)			
10MHz QPSK, Frequency: 3705 MHz								
151.59	H	28.67	-83.22	0.00	0.23	-83.45	-13.00	70.45
74.20	V	28.91	-76.21	-2.90	0.16	-79.27	-13.00	66.27
7410.000	H	40.19	-49.08	10.95	2.05	-40.18	-13.00	27.18
7410.000	V	37.59	-52.42	10.95	2.05	-43.52	-13.00	30.52
11115.000	H	36.15	-49.98	11.40	2.63	-41.21	-13.00	28.21
11115.000	V	36.33	-49.13	11.40	2.63	-40.36	-13.00	27.36
10MHz QPSK, Frequency: 3840 MHz								
64.03	H	28.98	-74.86	-8.16	0.14	-83.16	-13.00	70.16
120.03	V	28.60	-77.13	0.00	0.21	-77.34	-13.00	64.34
7680.000	H	46.79	-42.72	10.86	2.01	-33.87	-13.00	20.87
7680.000	V	39.70	-50.49	10.86	2.01	-41.64	-13.00	28.64
11520.000	H	35.57	-50.59	11.40	2.69	-41.88	-13.00	28.88
11520.000	V	36.19	-48.88	11.40	2.69	-40.17	-13.00	27.17
10MHz QPSK, Frequency: 3975 MHz								
49.93	H	28.63	-72.12	-14.97	0.12	-87.21	-13.00	74.21
408.94	V	28.54	-77.36	0.00	0.40	-77.76	-13.00	64.76
7950.000	H	41.22	-47.27	10.81	2.08	-38.54	-13.00	25.54
7950.000	V	37.05	-51.88	10.81	2.08	-43.15	-13.00	30.15
11925.000	H	36.45	-49.91	11.40	2.71	-41.22	-13.00	28.22
11925.000	V	36.75	-48.71	11.40	2.71	-40.02	-13.00	27.02

DC 5A N7:

Frequency (MHz)	Polar (H/V)	Receiver Reading (dB μ V)	Substituted Method			Absolute Level (dBm)	Limit (dBm)	Margin (dB)
			Substituted Level (dBm)	Antenna Gain (dBd/dBi)	Cable Loss (dB)			
5MHz QPSK, Frequency: 2502.5 MHz								
68.39	H	28.57	-75.23	-5.85	0.15	-81.23	-25.00	56.23
119.63	V	28.88	-76.87	0.00	0.21	-77.08	-25.00	52.08
5005.000	H	40.33	-52.63	11.20	1.47	-42.90	-25.00	17.90
5005.000	V	40.52	-52.30	11.20	1.47	-42.57	-25.00	17.57
7507.500	H	40.63	-49.16	10.90	1.95	-40.21	-25.00	15.21
7507.500	V	38.69	-51.60	10.90	1.95	-42.65	-25.00	17.65
5MHz QPSK, Frequency: 2535 MHz								
42.90	H	28.61	-60.36	-22.57	0.12	-83.05	-25.00	58.05
321.06	V	29.06	-79.20	0.00	0.34	-79.54	-25.00	54.54
5070.000	H	36.47	-56.72	11.24	1.47	-46.95	-25.00	21.95
5070.000	V	35.39	-57.70	11.24	1.47	-47.93	-25.00	22.93
7605.000	H	39.99	-49.48	10.88	2.01	-40.61	-25.00	15.61
7605.000	V	38.75	-51.44	10.88	2.01	-42.57	-25.00	17.57
5MHz QPSK, Frequency: 2567.5 MHz								
171.15	H	28.73	-83.37	0.00	0.24	-83.61	-25.00	58.61
95.62	V	28.55	-79.49	0.00	0.19	-79.68	-25.00	54.68
5135.000	H	41.41	-52.19	11.28	1.47	-42.38	-25.00	17.38
5135.000	V	38.80	-54.69	11.28	1.47	-44.88	-25.00	19.88
7702.500	H	41.95	-47.57	10.86	1.97	-38.68	-25.00	13.68
7702.500	V	37.88	-52.30	10.86	1.97	-43.41	-25.00	18.41

DC 5A N38:

Frequency (MHz)	Polar (H/V)	Receiver Reading (dBμV)	Substituted Method			Absolute Level (dBm)	Limit (dBm)	Margin (dB)
			Substituted Level (dBm)	Antenna Gain (dBd/dBi)	Cable Loss (dB)			
10MHz QPSK, Frequency:			2575 MHz					
528.24	H	28.80	-77.48	0.00	0.44	-77.92	-25.00	52.92
68.79	V	28.84	-74.18	-5.64	0.15	-79.97	-25.00	54.97
5150.000	H	39.23	-54.50	11.29	1.43	-44.64	-25.00	19.64
5150.000	V	35.43	-58.18	11.29	1.43	-48.32	-25.00	23.32
7725.000	H	37.10	-52.41	10.86	2.00	-43.55	-25.00	18.55
7725.000	V	36.58	-53.53	10.86	2.00	-44.67	-25.00	19.67
10MHz QPSK, Frequency:			2595 MHz					
60.20	H	28.53	-75.35	-10.19	0.14	-85.68	-25.00	60.68
42.12	V	28.63	-63.94	-23.60	0.12	-87.66	-25.00	62.66
5190.000	H	44.05	-50.02	11.31	1.44	-40.15	-25.00	15.15
5190.000	V	36.97	-56.95	11.31	1.44	-47.08	-25.00	22.08
7785.000	H	35.62	-53.87	10.84	1.99	-45.02	-25.00	20.02
7785.000	V	35.65	-54.27	10.84	1.99	-45.42	-25.00	20.42
10MHz QPSK, Frequency:			2615 MHz					
55.93	H	28.65	-74.00	-12.17	0.14	-86.31	-25.00	61.31
100.42	V	28.72	-78.28	0.00	0.19	-78.47	-25.00	53.47
5230.000	H	43.68	-50.25	11.34	1.46	-40.37	-25.00	15.37
5230.000	V	39.53	-54.22	11.34	1.46	-44.34	-25.00	19.34
7845.000	H	36.10	-53.13	10.83	2.02	-44.32	-25.00	19.32
7845.000	V	36.04	-53.58	10.83	2.02	-44.77	-25.00	19.77

DC 40A N40:

Frequency (MHz)	Polar (H/V)	Receiver Reading (dB μ V)	Substituted Method			Absolute Level (dBm)	Limit (dBm)	Margin (dB)
			Substituted Level (dBm)	Antenna Gain (dBd/dBi)	Cable Loss (dB)			
10MHz QPSK, Frequency:			2310	MHz				
117.12	H	28.76	-83.37	0.00	0.20	-83.57	-40.00	43.57
297.88	V	28.69	-80.21	0.00	0.34	-80.55	-40.00	40.55
4620.000	H	35.15	-60.17	10.74	1.41	-50.84	-40.00	10.84
4620.000	V	34.21	-60.98	10.74	1.41	-51.65	-40.00	11.65
6930.000	H	40.45	-50.55	11.21	1.89	-41.23	-40.00	1.23
6930.000	V	37.20	-53.67	11.21	1.89	-44.35	-40.00	4.35

DC 5A N41:

Frequency (MHz)	Polar (H/V)	Receiver Reading (dB μ V)	Substituted Method			Absolute Level (dBm)	Limit (dBm)	Margin (dB)
			Substituted Level (dBm)	Antenna Gain (dBd/dBi)	Cable Loss (dB)			
10MHz QPSK, Frequency:			2501	MHz				
94.09	H	29.08	-83.68	0.00	0.18	-83.86	-25.00	58.86
107.48	V	28.79	-77.75	0.00	0.19	-77.94	-25.00	52.94
5002.000	H	40.86	-52.09	11.20	1.48	-42.37	-25.00	17.37
5002.000	V	39.51	-53.30	11.20	1.48	-43.58	-25.00	18.58
7503.000	H	47.88	-41.93	10.90	1.94	-32.97	-25.00	7.97
7503.000	V	39.90	-50.40	10.90	1.94	-41.44	-25.00	16.44
10MHz QPSK, Frequency:			2593	MHz				
42.48	H	28.62	-59.69	-23.13	0.12	-82.94	-25.00	57.94
220.40	V	28.51	-81.47	0.00	0.27	-81.74	-25.00	56.74
5186.000	H	44.05	-49.98	11.31	1.44	-40.11	-25.00	15.11
5186.000	V	41.97	-51.92	11.31	1.44	-42.05	-25.00	17.05
7779.000	H	41.91	-47.58	10.84	1.99	-38.73	-25.00	13.73
7779.000	V	37.31	-52.63	10.84	1.99	-43.78	-25.00	18.78
10MHz QPSK, Frequency:			2685	MHz				
258.06	H	28.64	-83.07	0.00	0.31	-83.38	-25.00	58.38
82.35	V	28.60	-80.16	0.00	0.16	-80.32	-25.00	55.32
5370.000	H	37.68	-55.83	11.42	1.48	-45.89	-25.00	20.89
5370.000	V	36.18	-57.30	11.42	1.48	-47.36	-25.00	22.36
8055.000	H	36.57	-51.63	10.81	2.15	-42.97	-25.00	17.97
8055.000	V	37.43	-51.26	10.81	2.15	-42.60	-25.00	17.60

DC 2A N66:

Frequency (MHz)	Polar (H/V)	Receiver Reading (dB μ V)	Substituted Method			Absolute Level (dBm)	Limit (dBm)	Margin (dB)
			Substituted Level (dBm)	Antenna Gain (dBd/dBi)	Cable Loss (dB)			
5MHz QPSK, Frequency: 1712.5 MHz								
123.48	H	28.72	-83.41	0.00	0.20	-83.61	-13.00	70.61
188.17	V	28.81	-80.77	0.00	0.26	-81.03	-13.00	68.03
3425.000	H	36.49	-61.28	10.37	1.17	-52.08	-13.00	39.08
3425.000	V	35.41	-62.33	10.37	1.17	-53.13	-13.00	40.13
5137.500	H	50.86	-42.76	11.28	1.46	-32.94	-13.00	19.94
5137.500	V	48.74	-44.77	11.28	1.46	-34.95	-13.00	21.95
5MHz QPSK, Frequency: 1745 MHz								
74.56	H	28.60	-77.92	-2.72	0.16	-80.80	-13.00	67.80
89.54	V	28.84	-80.46	0.00	0.18	-80.64	-13.00	67.64
3490.000	H	36.57	-61.27	10.40	1.17	-52.04	-13.00	39.04
3490.000	V	36.97	-60.81	10.40	1.17	-51.58	-13.00	38.58
5235.000	H	46.54	-47.36	11.34	1.46	-37.48	-13.00	24.48
5235.000	V	42.18	-51.53	11.34	1.46	-41.65	-13.00	28.65
5MHz QPSK, Frequency: 1777.5 MHz								
139.10	H	28.87	-83.42	0.00	0.22	-83.64	-13.00	70.64
53.50	V	29.37	-73.53	-13.29	0.13	-86.95	-13.00	73.95
3555.000	H	36.18	-61.51	10.46	1.22	-52.27	-13.00	39.27
3555.000	V	36.26	-61.32	10.46	1.22	-52.08	-13.00	39.08
5332.500	H	44.40	-49.07	11.40	1.47	-39.14	-13.00	26.14
5332.500	V	42.83	-50.48	11.40	1.47	-40.55	-13.00	27.55

DC 41A N77:

Frequency (MHz)	Polar (H/V)	Receiver Reading (dBμV)	Substituted Method			Absolute Level (dBm)	Limit (dBm)	Margin (dB)
			Substituted Level (dBm)	Antenna Gain (dBd/dBi)	Cable Loss (dB)			
10MHz QPSK, Frequency:			3705	MHz				
416.17	H	28.55	-80.28	0.00	0.39	-80.67	-13.00	67.67
158.19	V	20.73	-87.59	0.00	0.23	-87.82	-13.00	74.82
7410.000	H	47.48	-41.79	10.95	2.05	-32.89	-13.00	19.89
7410.000	V	39.73	-50.28	10.95	2.05	-41.38	-13.00	28.38
11115.000	H	36.94	-49.19	11.40	2.63	-40.42	-13.00	27.42
11115.000	V	36.59	-48.87	11.40	2.63	-40.10	-13.00	27.10
10MHz QPSK, Frequency:			3840	MHz				
116.20	H	28.69	-83.45	0.00	0.20	-83.65	-13.00	70.65
266.60	V	29.02	-81.23	0.00	0.31	-81.54	-13.00	68.54
7680.000	H	42.06	-47.45	10.86	2.01	-38.60	-13.00	25.60
7680.000	V	40.46	-49.73	10.86	2.01	-40.88	-13.00	27.88
11520.000	H	35.58	-50.58	11.40	2.69	-41.87	-13.00	28.87
11520.000	V	36.73	-48.34	11.40	2.69	-39.63	-13.00	26.63
10MHz QPSK, Frequency:			3975	MHz				
49.81	H	28.75	-71.79	-15.09	0.12	-87.00	-13.00	74.00
470.52	V	28.65	-75.08	0.00	0.43	-75.51	-13.00	62.51
7950.000	H	48.60	-39.89	10.81	2.08	-31.16	-13.00	18.16
7950.000	V	35.93	-53.00	10.81	2.08	-44.27	-13.00	31.27
11925.000	H	36.72	-49.64	11.40	2.71	-40.95	-13.00	27.95
11925.000	V	36.96	-48.50	11.40	2.71	-39.81	-13.00	26.81

Note:

- 1) The unit of Antenna Gain is dBd for frequency below 1GHz, and the unit of Antenna Gain is dBi for frequency above 1GHz.
- 2) Absolute Level = Substituted Level - Cable loss + Antenna Gain
- 3) Margin = Limit-Absolute Level

5. EUT PHOTOGRAPHS

Please refer to the attachment CR231165634-EXP EUT EXTERNAL PHOTOGRAPHS and CR231165634-INP EUT INTERNAL PHOTOGRAPHS

6. TEST SETUP PHOTOGRAPHS

Please refer to the attachment CR231165634-00G-TSP TEST SETUP PHOTOGRAPHS.

==== END OF REPORT =====