

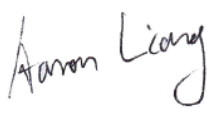

# RF TEST REPORT

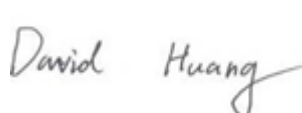

Report No.: 18070029-FCC-R3

Supersede Report No.: N/A

Applicant	TECNO MOBILE LIMITED	
Product Name	Mobile phone	
Model No.	CA7	
Serial No.	N/A	
Test Standard	FCC Part 15.247: 2016, ANSI C63.10: 2013	
Test Date	January 10 to February 06, 2018	
Issue Date	February 07, 2018	
Test Result	<input checked="" type="checkbox"/> Pass <input type="checkbox"/> Fail	
Equipment complied with the specification	<input checked="" type="checkbox"/>	
Equipment did not comply with the specification	<input type="checkbox"/>	
		
Aarron Liang Test Engineer	David Huang Checked By	
This test report may be reproduced in full only Test result presented in this test report is applicable to the tested sample only		

Issued by:

**SIEMIC (SHENZHEN-CHINA) LABORATORIES**

Zone A, Floor 1, Building 2 Wan Ye Long Technology Park

South Side of Zhoushi Road, Bao' an District, Shenzhen, Guangdong China 518108

Phone: +86 0755 2601 4629801 Email: [China@siemic.com.cn](mailto:China@siemic.com.cn)

## Laboratories Introduction

SIEMIC, headquartered in the heart of Silicon Valley, with superior facilities in US and Asia, is one of the leading independent testing and certification facilities providing customers with one-stop shop services for Compliance Testing and Global Certifications.



In addition to testing and certification, SIEMIC provides initial design reviews and compliance management throughout a project. Our extensive experience with China, Asia Pacific, North America, European, and International compliance requirements, assures the fastest, most cost effective way to attain regulatory compliance for the global markets.

### Accreditations for Conformity Assessment

Country/Region	Scope
USA	EMC, RF/Wireless, SAR, Telecom
Canada	EMC, RF/Wireless, SAR, Telecom
Taiwan	EMC, RF, Telecom, SAR, Safety
Hong Kong	RF/Wireless, SAR, Telecom
Australia	EMC, RF, Telecom, SAR, Safety
Korea	EMI, EMS, RF, SAR, Telecom, Safety
Japan	EMI, RF/Wireless, SAR, Telecom
Singapore	EMC, RF, SAR, Telecom
Europe	EMC, RF, SAR, Telecom, Safety

Test Report	18070029-FCC-R3
Page	3 of 55

This page has been left blank intentionally.

# CONTENTS

1. REPORT REVISION HISTORY .....	5
2. CUSTOMER INFORMATION.....	5
3. TEST SITE INFORMATION .....	5
4. EQUIPMENT UNDER TEST (EUT) INFORMATION .....	6
5. TEST SUMMARY .....	8
6. MEASUREMENTS, EXAMINATION AND DERIVED RESULTS.....	9
6.1 ANTENNA REQUIREMENT .....	9
6.2 CHANNEL SEPARATION.....	10
6.3 20DB BANDWIDTH .....	14
6.4 PEAK OUTPUT POWER .....	18
6.5 NUMBER OF HOPPING CHANNEL .....	22
6.6 TIME OF OCCUPANCY (DWELL TIME).....	24
6.7 BAND EDGE & RESTRICTED BAND .....	28
6.8 AC POWER LINE CONDUCTED EMISSIONS.....	36
6.9 RADIATED EMISSIONS & RESTRICTED BAND.....	42
ANNEX A. TEST INSTRUMENT.....	49
ANNEX C. TEST SETUP AND SUPPORTING EQUIPMENT.....	50
ANNEX D. USER MANUAL / BLOCK DIAGRAM / SCHEMATICS / PARTLIST .....	54
ANNEX E. DECLARATION OF SIMILARITY .....	55

## 1. Report Revision History

Report No.	Report Version	Description	Issue Date
18070029-FCC-R3	NONE	Original	February 07, 2018

## 2. Customer information

Applicant Name	TECNO MOBILE LIMITED
Applicant Add	ROOMS 05-15, 13A/F., SOUTH TOWER, WORLD FINANCE CENTRE, HARBOUR CITY, 17 CANTON ROAD, TSIM SHA TSUI, KOWLOON, HONG KONG
Manufacturer	SHENZHEN TECNO TECHNOLOGY CO.,LTD.
Manufacturer Add	1-4th Floor,3rd Building,Pacific Industrial Park,No.2088,Shenyan Road,Yantian District,Shenzhen,Guangdong,China

## 3. Test site information

### Test Lab A:

Lab performing tests	SIEMIC (Shenzhen-China) LABORATORIES
Lab Address	Zone A, Floor 1, Building 2 Wan Ye Long Technology Park South Side of Zhoushi Road, Bao' an District, Shenzhen, Guangdong China 518108
FCC Test Site No.	535293
IC Test Site No.	4842E-1
Test Software	Radiated Emission Program-To Shenzhen v2.0

### Test Lab B:

Lab performing tests	SIEMIC (Nanjing-China) Laboratories
Lab Address	2-1 Longcang Avenue Yuhua Economic and Technology Development Park, Nanjing, China
FCC Test Site No.	694825
IC Test Site No.	4842B-1
Test Software	EZ_EMV(ver.lcp-03A1)

Note: We just perform Radiated Spurious Emission above 18GHz in the test Lab. B.

## 4. Equipment under Test (EUT) Information

Description of EUT:	Mobile phone
Main Model:	CA7
Serial Model:	N/A
Date EUT received:	January 09, 2018
Test Date(s):	January 10 to February 06, 2018
Equipment Category :	DSS
Antenna Gain:	GSM850: -0.2dBi PCS1900: 1.7dBi UMTS-FDD Band V: -0.2dBi UMTS-FDD Band II: 1.7dBi LTE Band II: 1.7dBi LTE Band IV: 1.7dBi LTE Band V: -0.2dBi LTE Band VII: 2.5dBi WIFI: 2.0dBi Bluetooth/BLE: 2.0dBi GPS: 2dBi
Antenna Type:	PIFA antenna
Type of Modulation:	GSM / GPRS: GMSK EGPRS: GMSK,8PSK UMTS-FDD: QPSK LTE Band: QPSK, 16QAM 802.11b/g/n: DSSS, OFDM Bluetooth: GFSK, $\pi$ /4DQPSK, 8DPSK BLE: GFSK GPS: BPSK
RF Operating Frequency (ies):	GSM850 TX: 824.2 ~ 848.8 MHz; RX: 869.2 ~ 893.8 MHz PCS1900 TX: 1850.2 ~ 1909.8 MHz; RX: 1930.2 ~ 1989.8 MHz

UMTS-FDD Band V TX: 826.4 ~ 846.6 MHz; RX: 871.4 ~ 891.6 MHz  
 UMTS-FDD Band II TX:1852.4 ~ 1907.6 MHz;  
 RX: 1932.4 ~ 1987.6 MHz  
 LTE Band II TX: 1850.7 ~ 1909.3MHz; RX : 1930.7 ~ 1989.3 MHz  
 LTE Band IV TX: 1710.7 ~ 1754.3 MHz; RX : 2110.7~ 2154.3 MHz  
 LTE Band V TX: 824.7~ 848.3 MHz; RX : 869.7 ~ 893.3MHz  
 LTE Band VII TX: 2502.5 ~ 2567.5 MHz; RX : 2622.5 ~ 2687.5 MHz  
 WIFI: 802.11b/g/n(20M): 2412-2462 MHz  
 WIFI: 802.11n(40M): 2422-2452 MHz  
 Bluetooth& BLE: 2402-2480 MHz  
 GPS: 1575.42 MHz

Max. Output Power: 5.320dBm

Number of Channels: GSM 850: 124CH  
 PCS1900: 299CH  
 UMTS-FDD Band V: 102CH  
 UMTS-FDD Band II: 277CH  
 WIFI :802.11b/g/n(20M): 11CH  
 WIFI :802.11n(40M): 7CH  
 Bluetooth: 79CH  
 BLE: 40CH  
 GPS:1CH

Port: USB Port, Earphone Port

Input Power: Adapter:  
 Model: A88-502000  
 Input: AC100-240V~50/60Hz, 0.35A  
 Output: DC 5.0V, 2.0A  
 Battery  
 Model: BL-36BT  
 Rating: 3.85V, 3650mAh/3750mAh, 14.05Wh/14.43Wh  
 Limited charge voltage: 4.4V

Trade Name : TECNO

FCC ID: 2ADYY-CA7

## 5. Test Summary

The product was tested in accordance with the following specifications.

All testing has been performed according to below product classification:

FCC Rules	Description of Test	Result
§15.203	Antenna Requirement	Compliance
§15.247(a)(1)	Channel Separation	Compliance
§15.247(a)(1)	20 dB Bandwidth	Compliance
§15.247(b)(1)	Peak Output Power	Compliance
§15.247(a)(1)(iii)	Number of Hopping Channel	Compliance
§15.247(a)(1)(iii)	Time of Occupancy (Dwell Time)	Compliance
§15.247(d)	Band Edge& Restricted Band	Compliance
§15.207(a)	AC Line Conducted Emissions	Compliance
§15.205, §15.209, §15.247(d)	Radiated Emissions& Restricted Band	Compliance

### Measurement Uncertainty

Emissions		
Test Item	Description	Uncertainty
Band Edge& Restricted Band and Radiated Emissions& Restricted Band	Confidence level of approximately 95% (in the case where distributions are normal), with a coverage factor of 2 (for EUTs < 0.5m X 0.5m X 0.5m)	+5.6dB/-4.5dB
-	-	-



## 6. Measurements, Examination And Derived Results

### 6.1 Antenna Requirement

#### **Applicable Standard**

According to § 15.203, an intentional radiator shall be designed to ensure that no antenna other than that furnished by the responsible party shall be used with the device. The use of a permanently attached antenna or of an antenna that uses a unique coupling to the intentional radiator shall be considered sufficient to comply with the provisions of this section. The manufacturer may design the unit so that a broken antenna can be replaced by the user, but the user of a standard antenna jack or electrical connector is prohibited. The structure and application of the EUT were analyzed to determine compliance with section §15.203 of the rules. §15.203 state that the subject device must meet the following criteria:

- a. Antenna must be permanently attached to the unit.
- b. Antenna must use a unique type of connector to attach to the EUT.

Unit must be professionally installed, and installer shall be responsible for verifying that the correct antenna is employed with the unit.

And according to FCC 47 CFR section 15.247 (b), if the transmitting antennas of directional gain greater than 6dBi are used, the power shall be reduced by the amount in dB that the directional gain of the antenna exceeds 6 dBi.

#### **Antenna Connector Construction**

The EUT has 2 antennas:

A permanently attached PIFA antenna for Bluetooth/BLE/WIF/GPS, the gain is 2.0dBi for Bluetooth/BLE/WIF/GPS.

A permanently attached PIFA antenna for GSM/PCS/UMTS/ LTE Band II/IV/V/VII, the gain is -0.2dBi for GSM850/ UMTS-FDD Band V, 1.7dBi for PCS1900/UMTS-FDD Band II, the gain is 1.7dBi for LTE Band II, 1.7dBi for LTE Band IV, -0.2dBi for LTE Band V, 2.5dBi for LTE Band VII.

**The antenna meets up with the ANTENNA REQUIREMENT.**

**Result:** Compliance.

## 6.2 Channel Separation

Temperature	24 °C
Relative Humidity	51%
Atmospheric Pressure	1012mbar
Test date :	February 03, 2018
Tested By :	Aarron Liang

### Requirement(s):

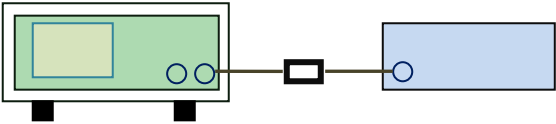
Spec	Item	Requirement	Applicable
§ 15.247(a)(1)	a)	Channel Separation < 20dB BW and 20dB BW < 25KHz ; Channel Separation Limit=25KHz Chanel Separation < 20dB BW and 20dB BW > 25kHz ; Channel Separation Limit=2/3 20dB BW	<input checked="" type="checkbox"/>
Test Setup	 <p style="text-align: center;">Spectrum Analyzer                      EUT</p>		
Test Procedure	<p>The test follows FCC Public Notice DA 00-705 Measurement Guidelines. Use the following spectrum analyzer settings:</p> <ul style="list-style-type: none"> <li>- The EUT must have its hopping function enabled</li> <li>- Span = wide enough to capture the peaks of two adjacent channels</li> <li>- Resolution (or IF) Bandwidth (RBW) ≥ 1% of the span</li> <li>- Video (or Average) Bandwidth (VBW) ≥ RBW</li> <li>- Sweep = auto</li> <li>- Detector function = peak</li> <li>- Trace = max hold</li> <li>- Allow the trace to stabilize. Use the marker-delta function to determine the separation between the peaks of the adjacent channels. The limit is specified in one of the subparagraphs of this Section. Submit this plot.</li> </ul>		

Remark	
Result	<input checked="" type="checkbox"/> Pass <input type="checkbox"/> Fail

Test Data  Yes  N/A

Test Plot  Yes (See below)  N/A

### Channel Separation measurement result

Type/ Modulation	CH	CH Frequency (MHz)	CH Separation (MHz)	Limit (MHz)	Result
CH Separation GFSK	Low Channel	2402	1.002	0.688	Pass
	Adjacency Channel	2403			
	Mid Channel	2440	1.002	0.687	Pass
	Adjacency Channel	2441			
	High Channel	2480	1.005	0.684	Pass
	Adjacency Channel	2479			
CH Separation $\pi$ / 4 DQPSK	Low Channel	2402	1.002	0.870	Pass
	Adjacency Channel	2403			
	Mid Channel	2440	1.002	0.879	Pass
	Adjacency Channel	2441			
	High Channel	2480	1.002	0.858	Pass
	Adjacency Channel	2479			
CH Separation 8DPSK	Low Channel	2402	1.002	0.863	Pass
	Adjacency Channel	2403			
	Mid Channel	2440	1.002	0.863	Pass
	Adjacency Channel	2441			
	High Channel	2480	1.005	0.855	Pass
	Adjacency Channel	2479			

## Test Plots

### Channel Separation measurement result

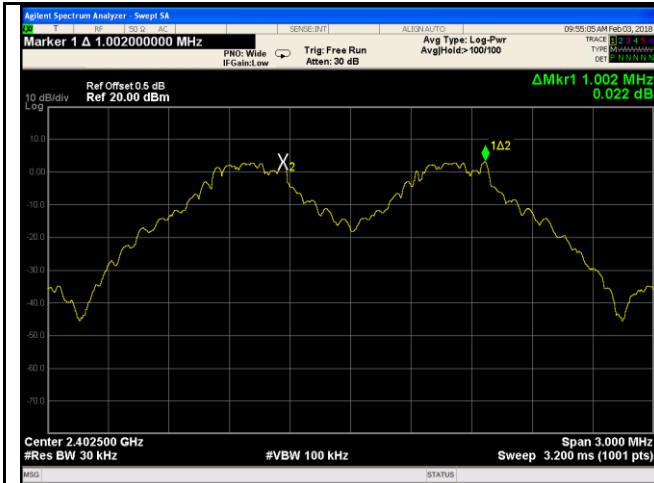

GFSK - Low Channel

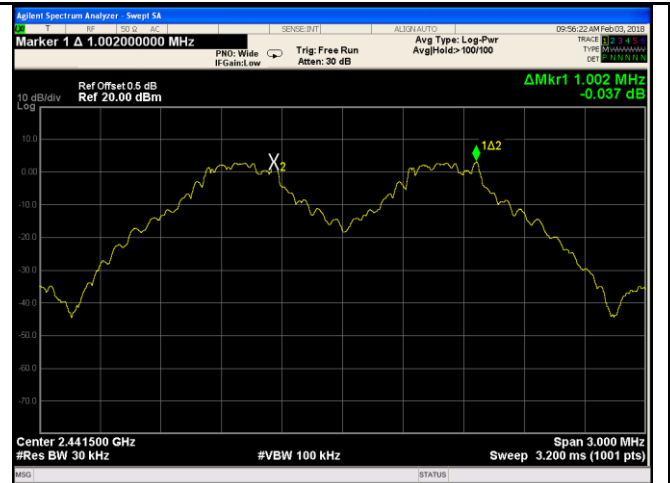

GFSK - Middle Channel

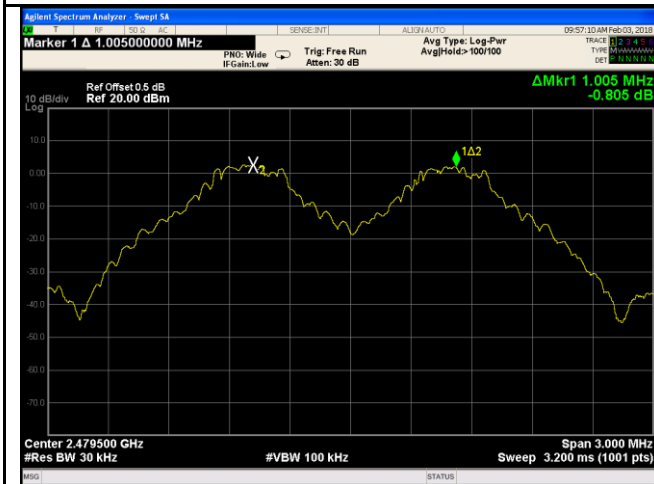

GFSK - High Channel

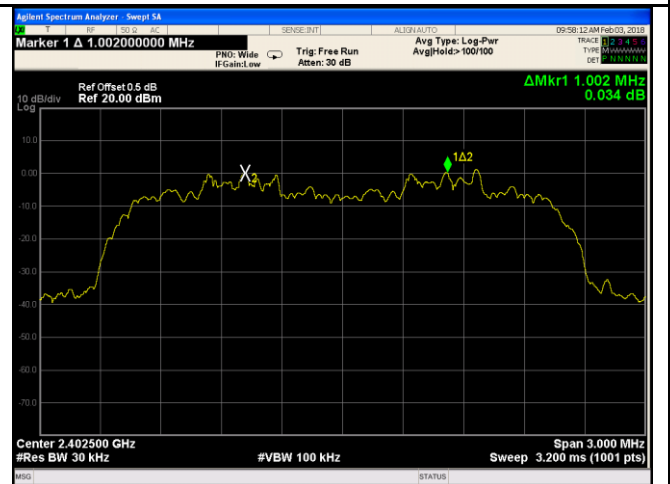

$\pi/4$  DPSK - Low Channel

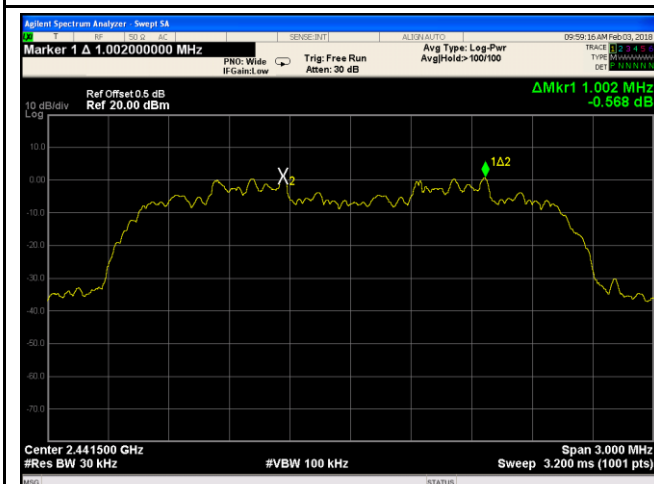

$\pi/4$  DQPSK - Middle Channel

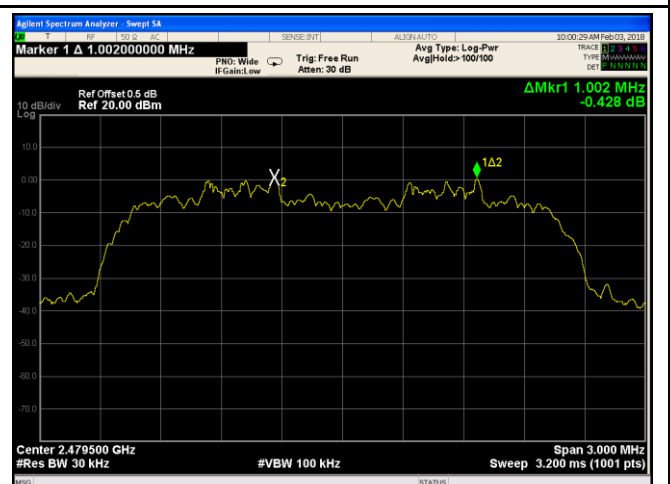

$\pi/4$  DQPSK - High Channel

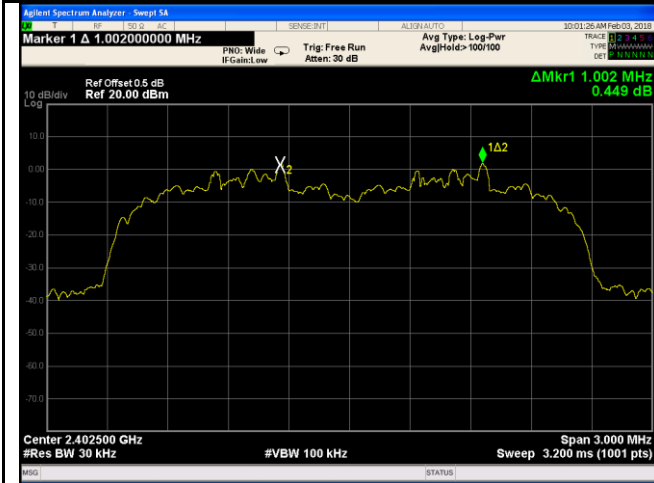

8DPSK - Low Channel

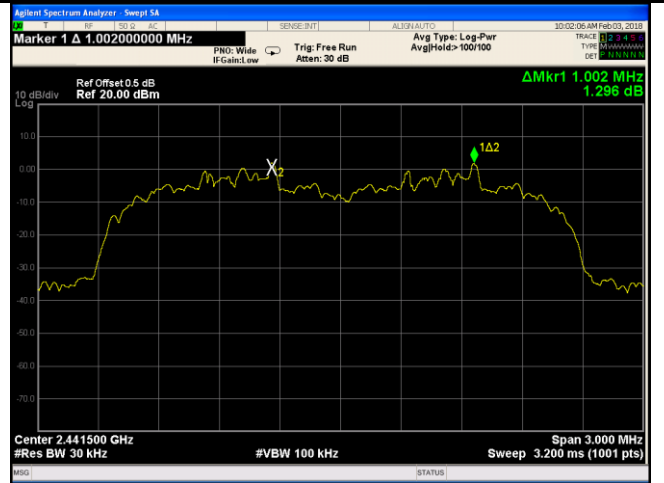

8DPSK - Middle Channel



8DPSK - High Channel

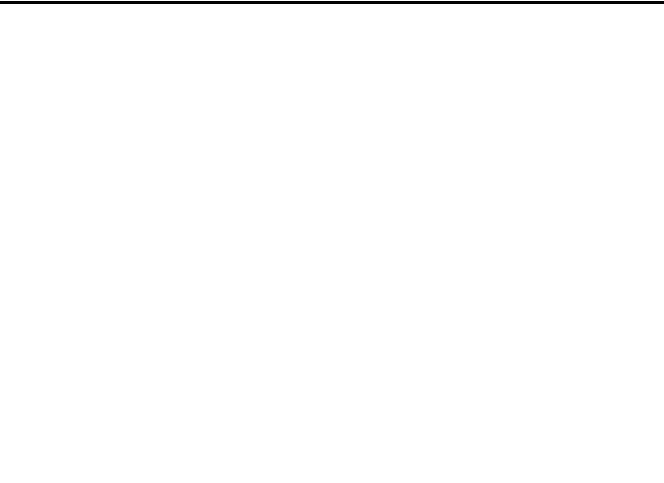

### 6.3 20dB Bandwidth

Temperature	24 °C
Relative Humidity	51%
Atmospheric Pressure	1012mbar
Test date :	February 03, 2018
Tested By :	Aarron Liang

**Requirement(s):**

Spec	Item	Requirement	Applicable
§15.247(a) (1)	a)	Frequency hopping systems shall have hopping channel carrier frequencies separated by a minimum of 25 kHz or the 20 dB bandwidth of the hopping channel, whichever is greater.	<input checked="" type="checkbox"/>

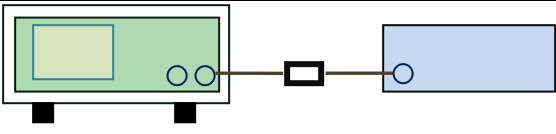
Test Setup	 <p style="text-align: center;">Spectrum Analyzer                      EUT</p>
------------	--

Test Procedure	<p>The test follows FCC Public Notice DA 00-705 Measurement Guidelines. Use the following spectrum analyzer settings:</p> <ul style="list-style-type: none"> <li>- Span = approximately 2 to 3 times the 20 dB bandwidth, centered on a hopping channel</li> <li>- RBW <math>\geq</math> 1% of the 20 dB bandwidth</li> <li>- VBW <math>\geq</math> RBW</li> <li>- Sweep = auto</li> <li>- Detector function = peak</li> <li>- Trace = max hold.</li> <li>- The EUT should be transmitting at its maximum data rate. Allow the trace to stabilize. Use the marker-to-peak function to set the marker to the peak of the emission. Use the marker-delta function to measure 20 dB down one side of the emission. Reset the marker-delta function, and move the marker to the other side of the emission, until it is (as close as possible to) even with the reference</li> </ul>
----------------	--

	marker level. The marker-delta reading at this point is the 20 dB bandwidth of the emission. If this value varies with different modes of operation (e.g., data rate, modulation format, etc.), repeat this test for each variation. The limit is specified in one of the subparagraphs of this Section. Submit this plot(s).
Remark	
Result	<input checked="" type="checkbox"/> Pass <input type="checkbox"/> Fail

Test Data  Yes  N/A

Test Plot  Yes (See below)  N/A

#### Measurement result

Modulation	CH	CH Frequency (MHz)	20dB Bandwidth (MHz)	99% Occupied Bandwidth (MHz)
GFSK	Low	2402	1.032	0.9079
	Mid	2441	1.031	0.9068
	High	2480	1.026	0.8918
$\pi$ /4 DQPSK	Low	2402	1.305	1.1824
	Mid	2441	1.319	1.1872
	High	2480	1.287	1.1778
8-DPSK	Low	2402	1.295	1.1957
	Mid	2441	1.294	1.1969
	High	2480	1.282	1.1954

## Test Plots

### 20dB Bandwidth measurement result

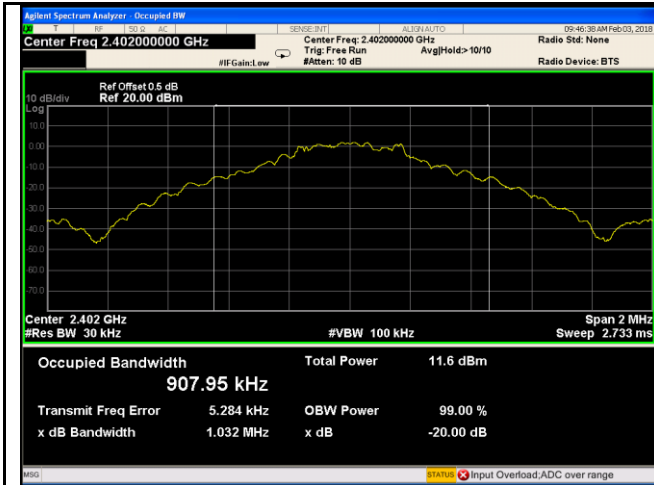

GFSK - Low Channel

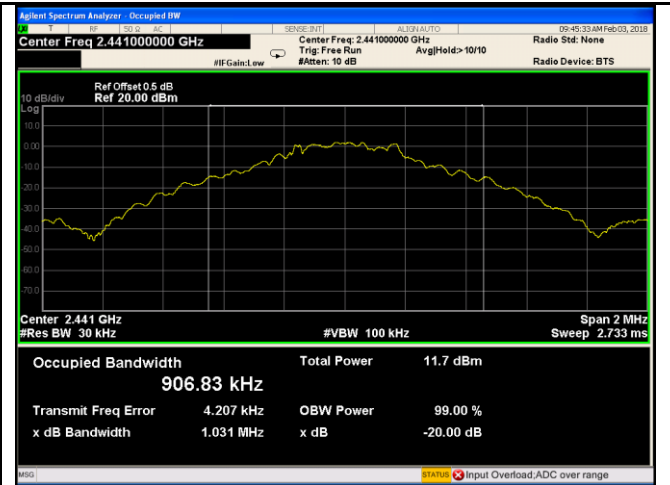

GFSK - Middle Channel

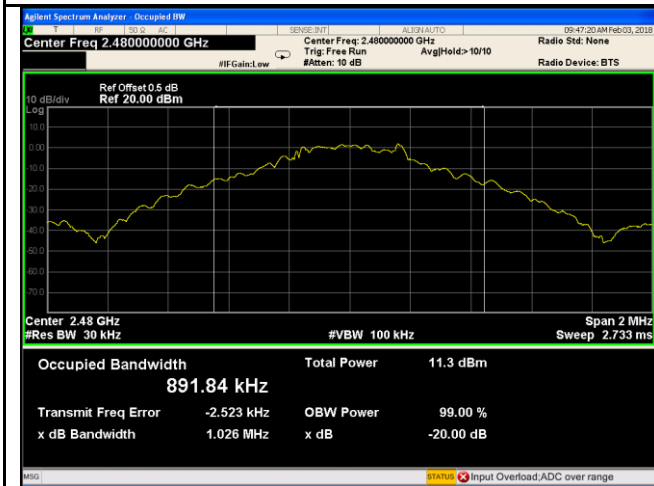

GFSK - High Channel

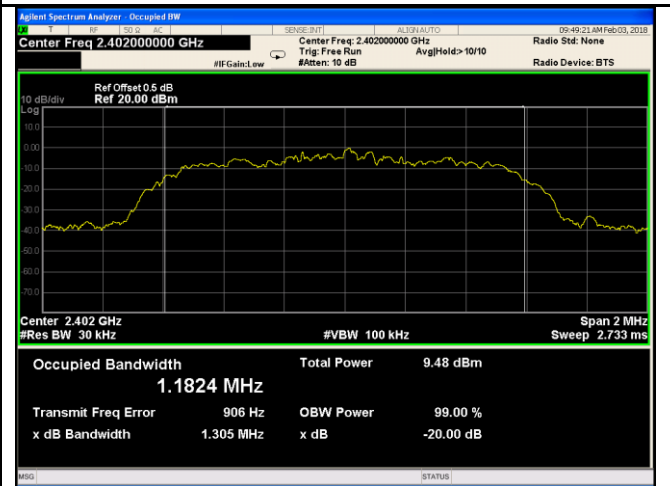

$\pi/4$  DPSK - Low Channel

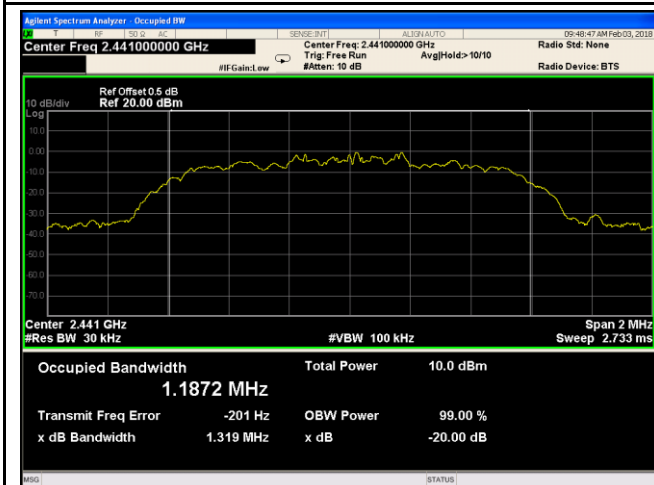

$\pi/4$  DQPSK - Middle Channel

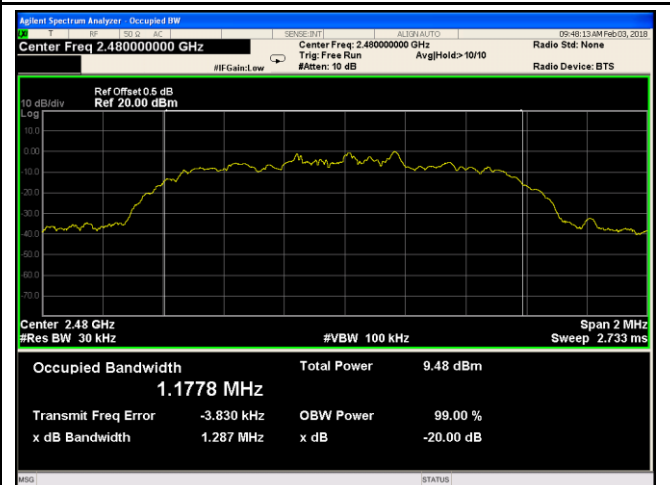

$\pi/4$  DQPSK - High Channel



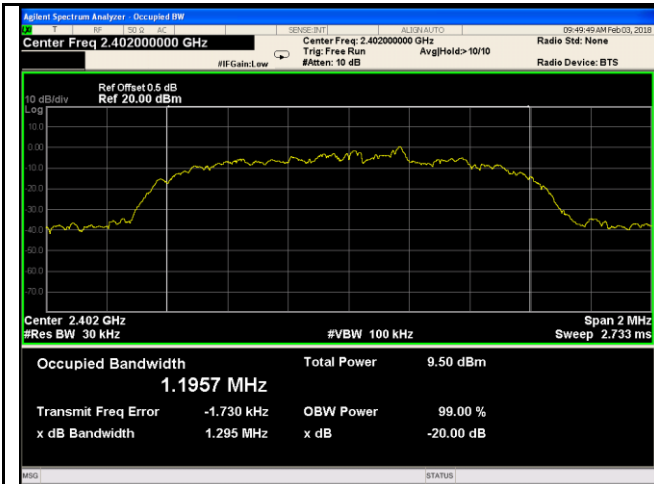

8DPSK - Low Channel

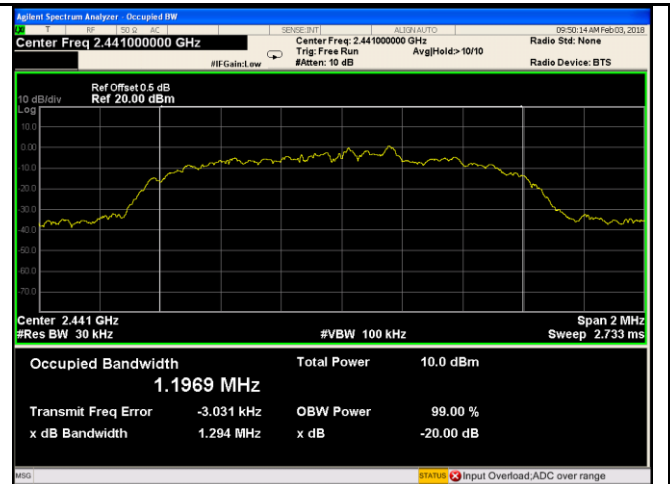

8DPSK - Middle Channel

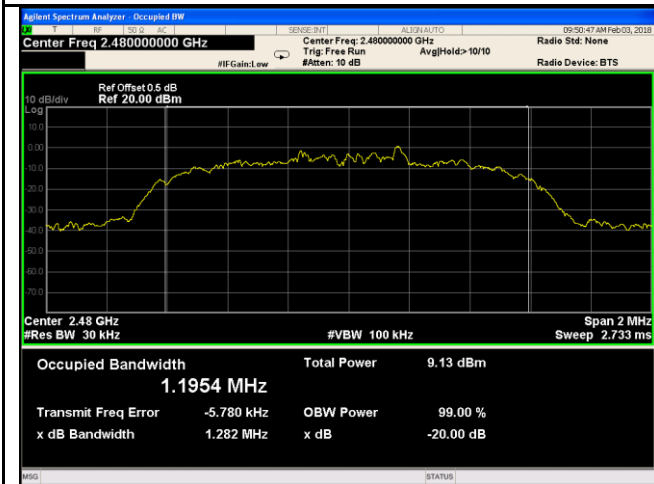

8DPSK - High Channel

## 6.4 Peak Output Power

Temperature	24 °C
Relative Humidity	51%
Atmospheric Pressure	1012mbar
Test date :	February 03, 2018
Tested By :	Aarron Liang

### Requirement(s):

Spec	Item	Requirement	Applicable
§15.247(b) (3)	a)	FHSS in 2400-2483.5MHz with $\geq 75$ channels: $\leq 1$ Watt	<input checked="" type="checkbox"/>
	b)	FHSS in 5725-5850MHz: $\leq 1$ Watt	<input type="checkbox"/>
	c)	For all other FHSS in the 2400-2483.5MHz band: $\leq 0.125$ Watt.	<input checked="" type="checkbox"/>
	d)	FHSS in 902-928MHz with $\geq 50$ channels: $\leq 1$ Watt	<input type="checkbox"/>
	e)	FHSS in 902-928MHz with $\geq 25$ & $< 50$ channels: $\leq 0.25$ Watt	<input type="checkbox"/>
	f)	DTS in 902-928MHz, 2400-2483.5MHz: $\leq 1$ Watt	<input type="checkbox"/>

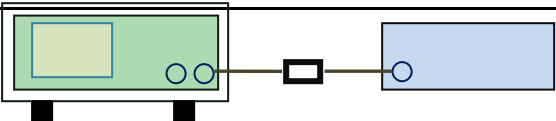
Test Setup	 <p style="text-align: center;">Spectrum Analyzer                      EUT</p>
------------	--

Test Procedure	<p>The test follows FCC Public Notice DA 00-705 Measurement Guidelines.</p> <p><u>Use the following spectrum analyzer settings:</u></p> <ul style="list-style-type: none"> <li>- Span = approximately 5 times the 20 dB bandwidth, centered on a hopping channel</li> <li>- RBW &gt; the 20 dB bandwidth of the emission being measured</li> <li>- VBW <math>\geq</math> RBW</li> <li>- Sweep = auto</li> <li>- Detector function = peak</li> <li>- Trace = max hold</li> <li>- Allow the trace to stabilize.</li> </ul>
----------------	--

	<ul style="list-style-type: none"> <li>- Use the marker-to-peak function to set the marker to the peak of the emission. The indicated level is the peak output power (see the note above regarding external attenuation and cable loss). The limit is specified in one of the subparagraphs of this Section. Submit this plot. A peak responding power meter may be used instead of a spectrum analyzer.</li> </ul>
Remark	
Result	<input checked="" type="checkbox"/> Pass <input type="checkbox"/> Fail

Test Data  Yes  N/A  
 Test Plot  Yes (See below)  N/A

**Peak Output Power measurement result**

Type	Modulation	CH	Frequency (MHz)	Conducted Power (dBm)	Limit (mW)	Result
Output power	GFSK	Low	2402	5.320	125	Pass
		Mid	2441	5.309	125	Pass
		High	2480	4.585	125	Pass
	$\pi/4$ DQPSK	Low	2402	4.560	125	Pass
		Mid	2441	4.646	125	Pass
		High	2480	3.905	125	Pass
	8-DPSK	Low	2402	4.780	125	Pass
		Mid	2441	4.883	125	Pass
		High	2480	4.059	125	Pass

## Test Plots

### Output Power measurement result

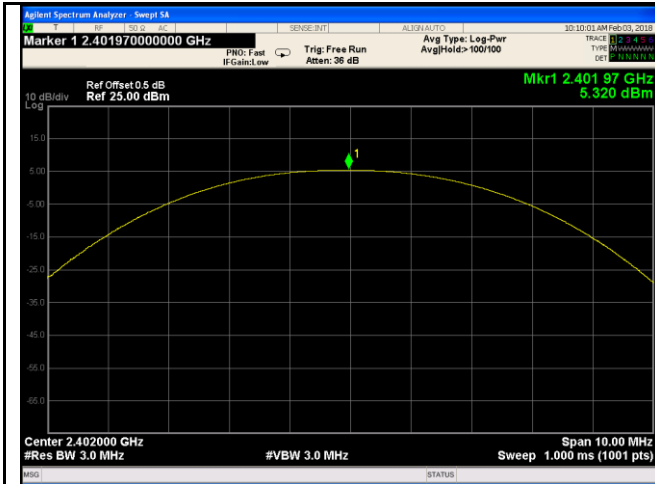

GFSK Output power - Low CH 2402

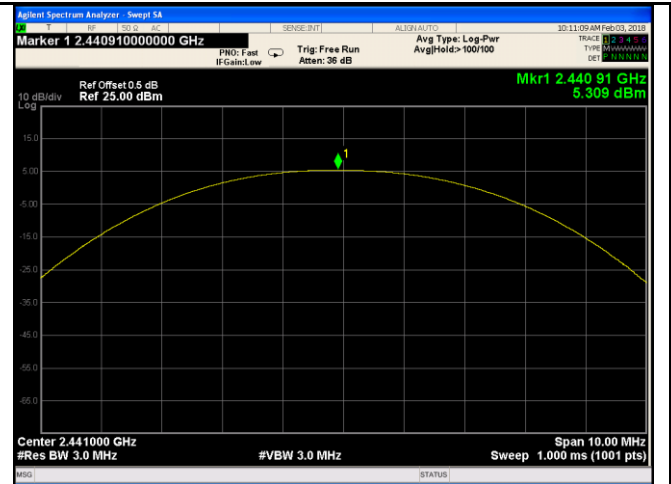

GFSK Output power - Mid CH 2441

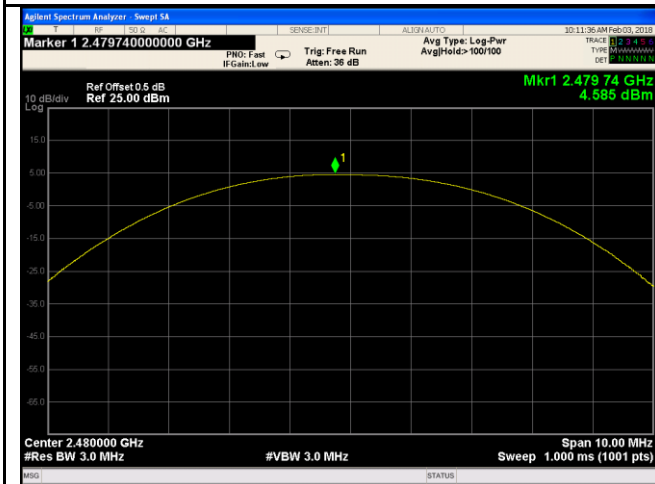

GFSK Output power - High CH 2480

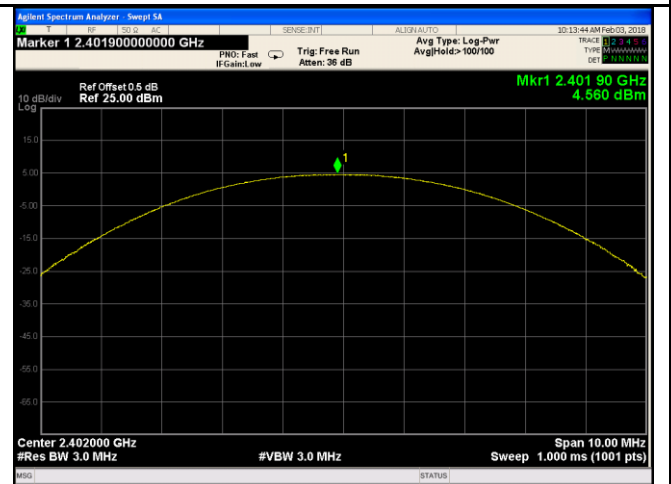

$\pi/4$  DQPSK Output power - Low CH 2402

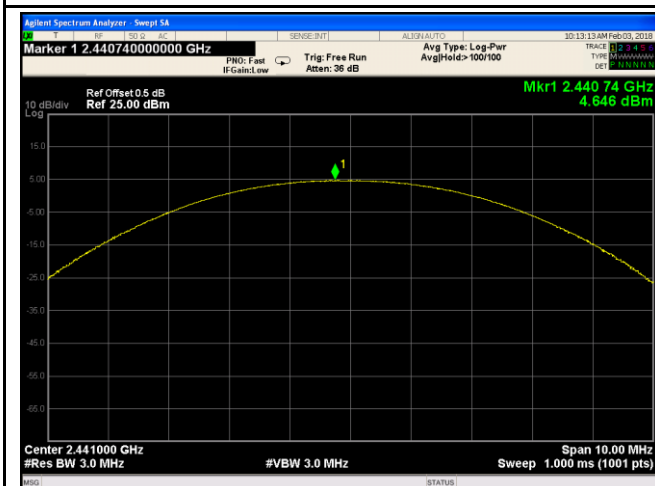

$\pi/4$  DQPSK Output power - Mid CH 2441

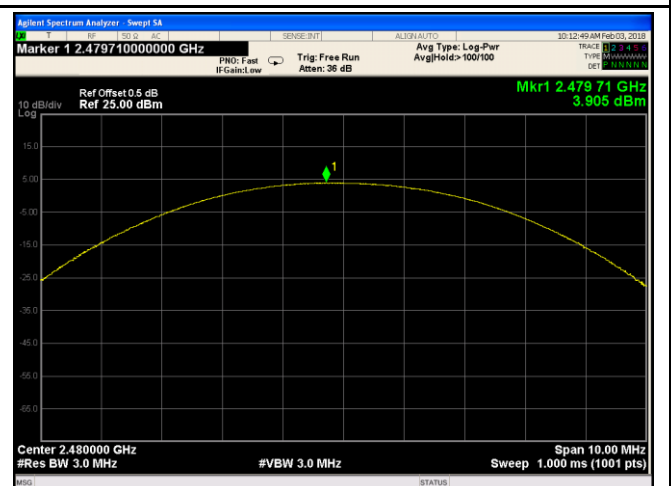

$\pi/4$  DQPSK Output power - High CH 2480

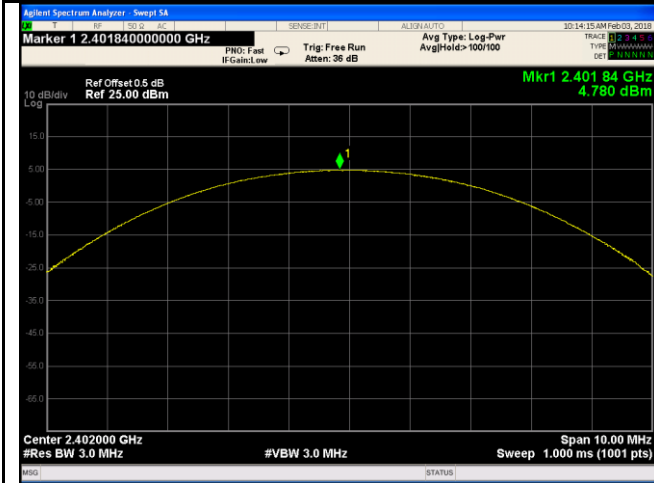

8DPSK Output power - Low CH 2402

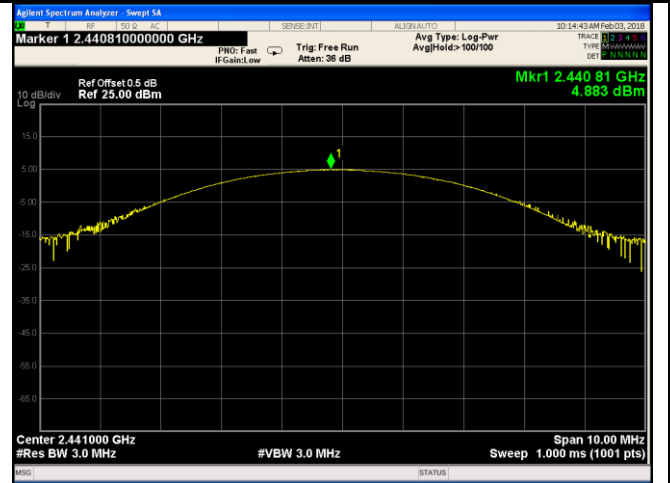

8DPSK Output power - Mid CH 2441

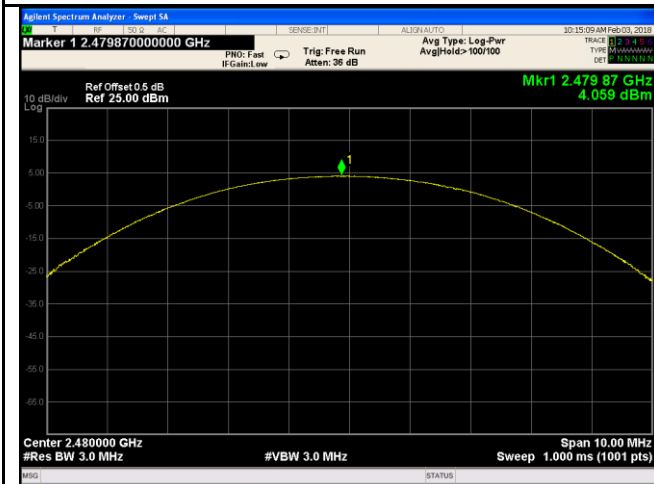

8DPSK Output power - High CH 2480

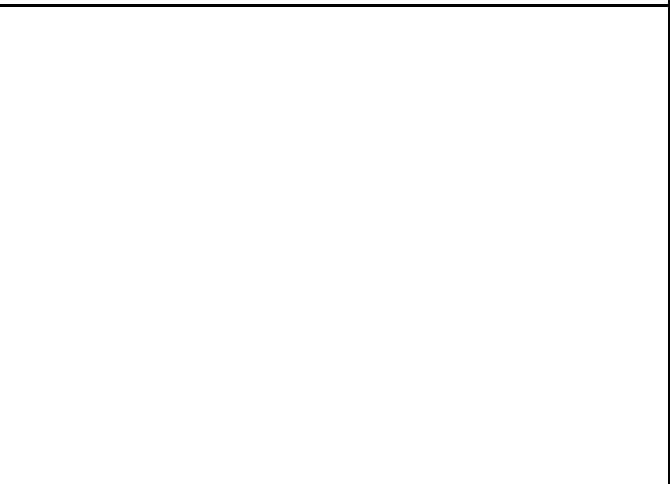

## 6.5 Number of Hopping Channel

Temperature	24 °C
Relative Humidity	51%
Atmospheric Pressure	1012mbar
Test date :	February 03, 2018
Tested By :	Aarron Liang

### Requirement(s):

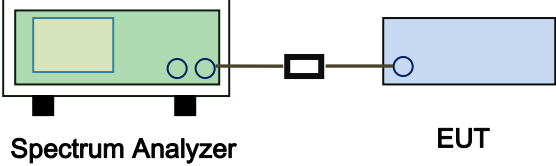
Spec	Item	Requirement	Applicable
§15.247(a) (1)(iii)	a)	FHSS in 2400-2483.5MHz ≥ 15 channels	<input checked="" type="checkbox"/>
Test Setup	 <p style="text-align: center;">Spectrum Analyzer                      EUT</p>		
Test Procedure	<p>The test follows FCC Public Notice DA 00-705 Measurement Guidelines.  <u>Use the following spectrum analyzer settings:</u>            The EUT must have its hopping function enabled.</p> <ul style="list-style-type: none"> <li>- Span = the frequency band of operation</li> <li>- RBW ≥ 1% of the span</li> <li>- VBW ≥ RBW</li> <li>- Sweep = auto</li> <li>- Detector function = peak</li> <li>- Trace = max hold</li> <li>- Allow trace to fully stabilize.</li> <li>- It may prove necessary to break the span up to sections, in order to clearly show all of the hopping frequencies. The limit is specified in one of the subparagraphs of this Section. Submit this plot(s).</li> </ul>		
Remark			
Result	<input checked="" type="checkbox"/> Pass <input type="checkbox"/> Fail		

Test Data     Yes                       N/A  
 Test Plot     Yes (See below)                       N/A

### Number of Hopping Channel measurement result

Type	Modulation	Frequency Range	Number of Hopping Channel	Limit
Number of Hopping Channel	GFSK	2400-2483.5	79	15
	$\pi/4$ DQPSK	2400-2483.5	79	15
	8-DPSK	2400-2483.5	79	15

### Test Plots

#### Number of Hopping Channels measurement result

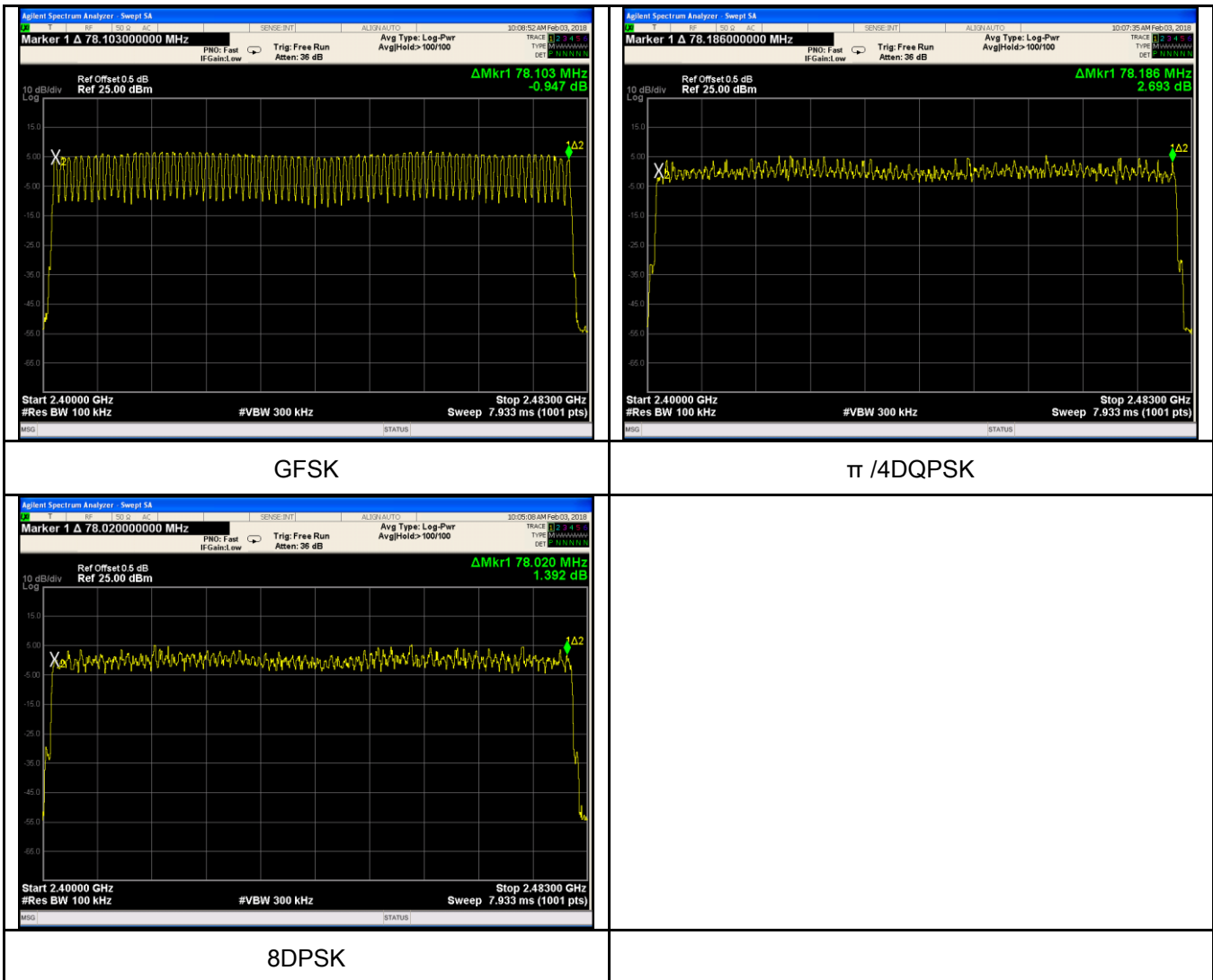

## 6.6 Time of Occupancy (Dwell Time)

Temperature	24 °C
Relative Humidity	51%
Atmospheric Pressure	1012mbar
Test date :	February 03, 2018
Tested By :	Aarron Liang

### Requirement(s):

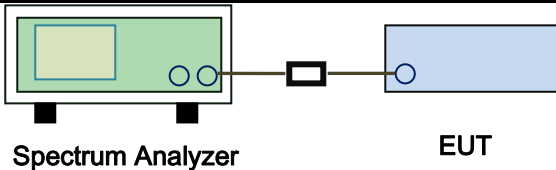
Spec	Item	Requirement	Applicable
§15.247(a) (1)(iii)	a)	Dwell Time < 0.4s	<input checked="" type="checkbox"/>
Test Setup	 <p style="text-align: center;">Spectrum Analyzer                      EUT</p>		
Test Procedure	<p>The test follows FCC Public Notice DA 00-705 Measurement Guidelines.  <u>Use the following spectrum analyzer</u></p> <ul style="list-style-type: none"> <li>- Span = zero span, centered on a hopping channel</li> <li>- RBW = 1 MHz</li> <li>- VBW ≥ RBW</li> <li>- Sweep = as necessary to capture the entire dwell time per hopping channel</li> <li>- Detector function = peak</li> <li>- Trace = max hold</li> <li>- use the marker-delta function to determine the dwell time</li> </ul>		
Remark			
Result	<input checked="" type="checkbox"/> Pass <input type="checkbox"/> Fail		

Test Data     Yes                       N/A  
 Test Plot     Yes (See below)                       N/A



**Dwell Time measurement result**

Type	Modulation	CH	Pulse Width (ms)	Dwell Time (ms)	Limit (ms)	Result
Dwell Time	GFSK	Low	2.95	314.667	400	Pass
		Mid	2.92	311.467	400	Pass
		High	2.99	318.933	400	Pass
	π /4 DQPSK	Low	2.93	312.533	400	Pass
		Mid	2.99	318.933	400	Pass
		High	2.93	312.533	400	Pass
	8-DPSK	Low	2.98	317.867	400	Pass
		Mid	2.96	315.733	400	Pass
		High	2.92	311.467	400	Pass
Note: Dwell time=Pulse Time (ms) × (1600 ÷ 6 ÷ 79) ×31.6						

## Test Plots

### Dwell Time measurement result

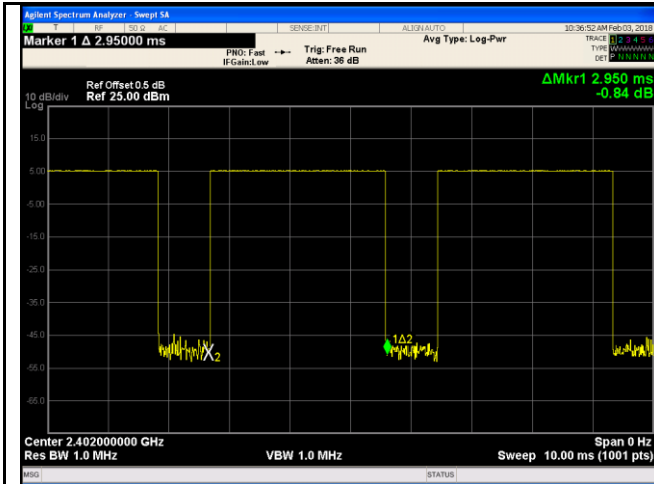

GFSK - Low CH 2402

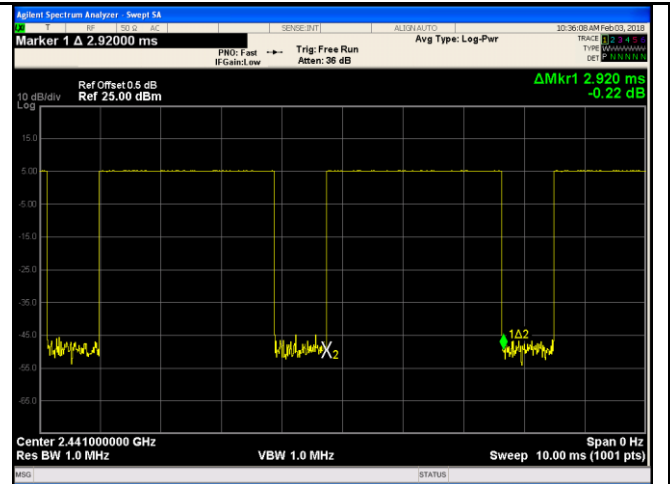

GFSK - Mid CH 2441

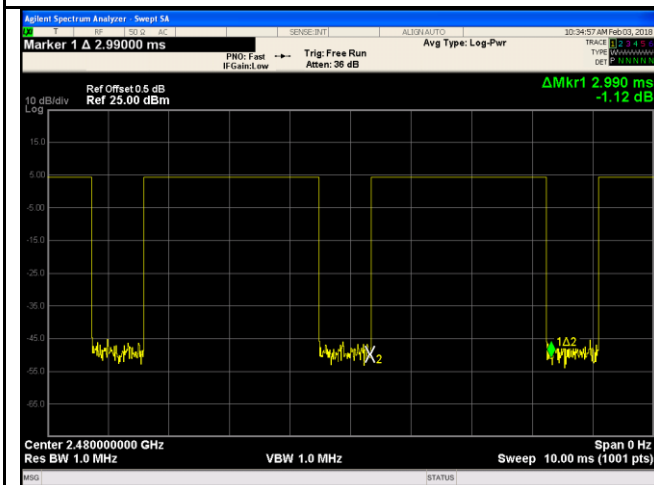

GFDK - High CH 2480

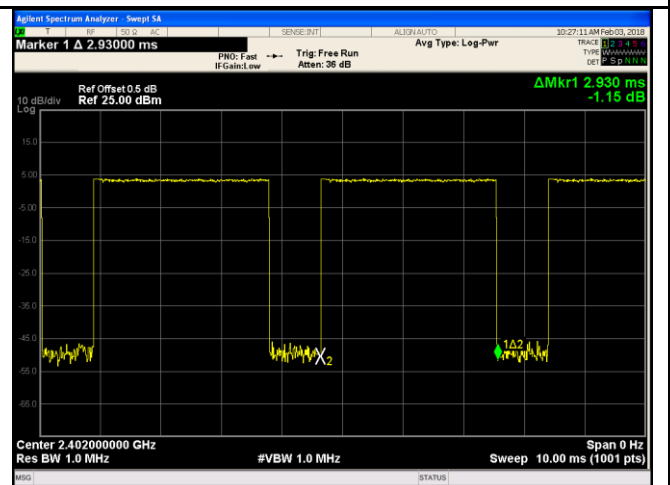

$\pi/4$  DQPSK - Low CH 2402

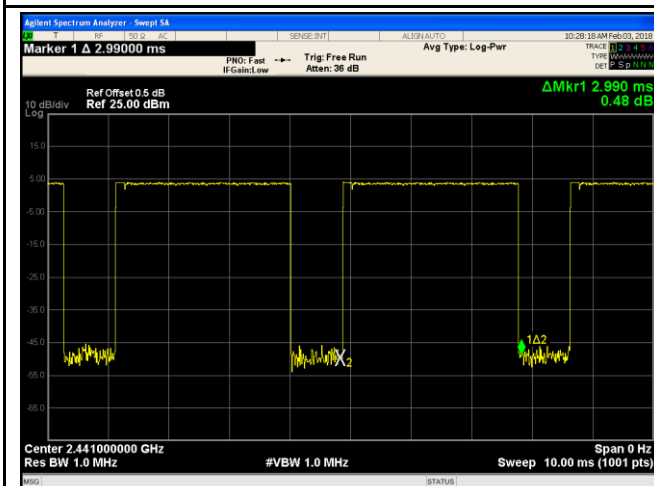

$\pi/4$  DQPSK - Mid CH 2441

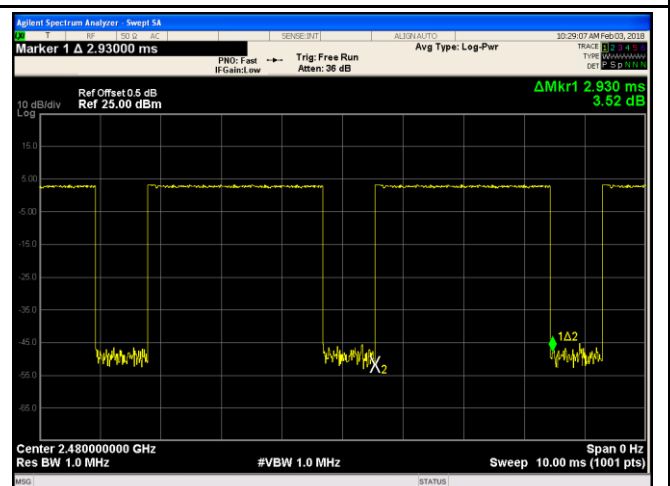

$\pi/4$  DQPSK - High CH 2480

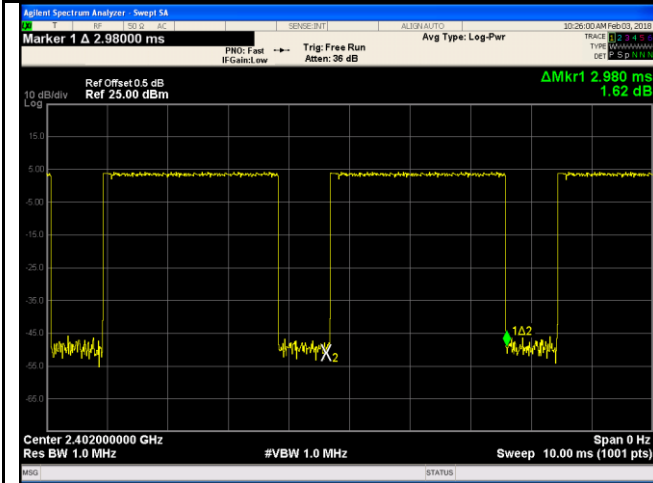

8DPSK - Low CH 2402

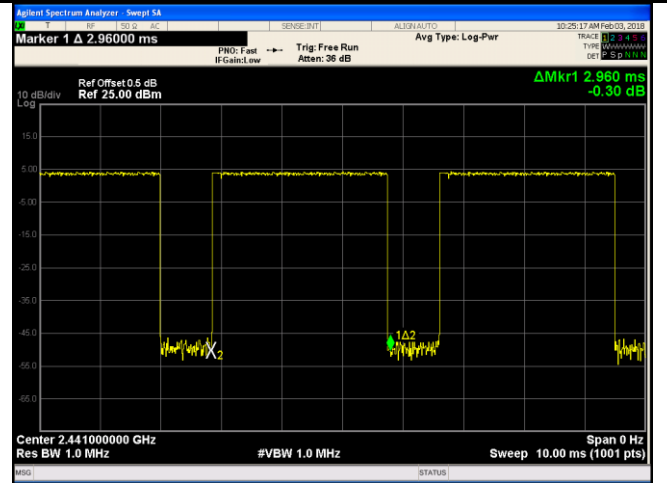

8DPSK - Mid CH 2441

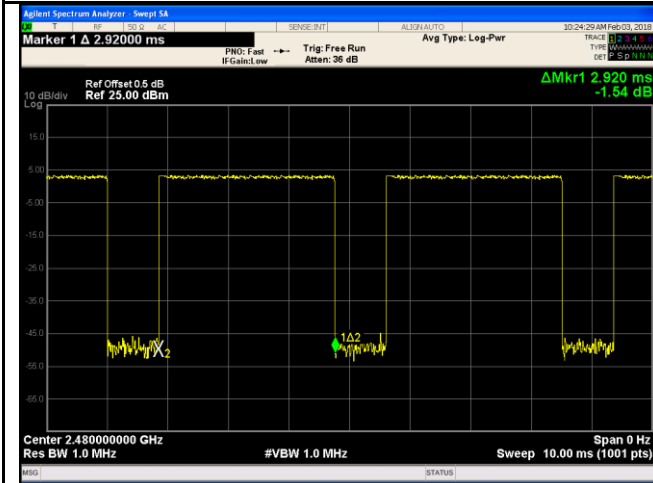

8DPSK - High CH 2480

## 6.7 Band Edge & Restricted Band

Temperature	25 °C
Relative Humidity	57%
Atmospheric Pressure	1024mbar
Test date :	January 24, 2018
Tested By :	Aarron Liang

### Requirement(s):

Spec	Item	Requirement	Applicable
§15.247(a) (1)(iii)	a)	In any 100 kHz bandwidth outside the frequency band in which the spread spectrum or digitally modulated intentional radiator is operating, the radio frequency power that is produced by the intentional radiator shall be at least 20 dB below that in the 100 kHz bandwidth within the band that contains the highest level of the desired power, based on either an RF conducted or a radiated measurement, provided the transmitter demonstrates compliance with the peak conducted power limits. □	<input checked="" type="checkbox"/>

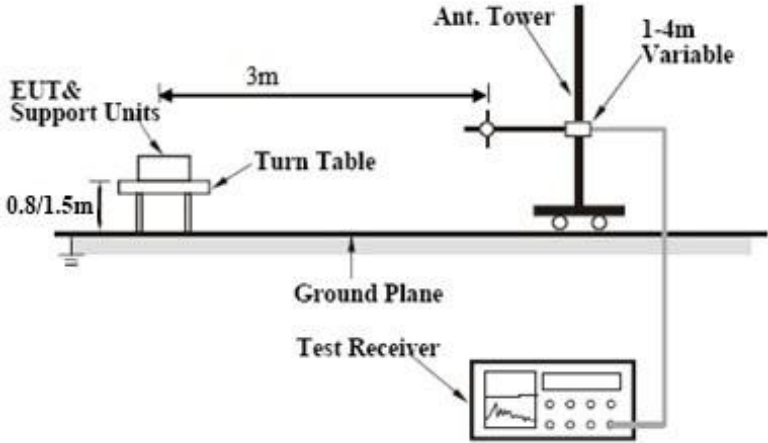
Test Setup	
------------	--

Test Procedure	<p>The test follows FCC Public Notice DA 00-705 Measurement Guidelines. Radiated Method Only</p> <ul style="list-style-type: none"> <li>- 1. Check the calibration of the measuring instrument using either an internal calibrator or a known signal from an external generator.</li> <li>- 2. Position the EUT without connection to measurement instrument. Put it on the Rotated table and turn on the EUT and make it operate in transmitting mode. Then set it to Low Channel and High Channel within its operating range,</li> </ul>
----------------	--

	<p>and make sure the instrument is operated in its linear range.</p> <ul style="list-style-type: none"> <li>- 3. First, set both RBW and VBW of spectrum analyzer to 100 kHz with a convenient frequency span including 100kHz bandwidth from band edge, check the emission of EUT, if pass then set Spectrum Analyzer as below: <ul style="list-style-type: none"> <li>a. The resolution bandwidth and video bandwidth of test receiver/spectrum analyzer is 120 kHz for Quasiy Peak detection at frequency below 1GHz.</li> <li>b. The resolution bandwidth of test receiver/spectrum analyzer is 1MHz and video bandwidth is 3MHz with Peak detection for Peak measurement at frequency above 1GHz.</li> <li>c. The resolution bandwidth of test receiver/spectrum analyzer is 1MHz and the video bandwidth is 10Hz with Peak detection for Average Measurement as below at frequency above 1GHz.</li> </ul> </li> <li>- 4. Measure the highest amplitude appearing on spectral display and set it as a reference level. Plot the graph with marking the highest point and edge frequency.</li> <li>- 5. Repeat above procedures until all measured frequencies were complete.</li> </ul>
Remark	
Result	<input checked="" type="checkbox"/> Pass <input type="checkbox"/> Fail

**Test Data**     Yes                       N/A  
**Test Plot**     Yes (See below)       N/A

### Test Plots

#### GFSK Mode:

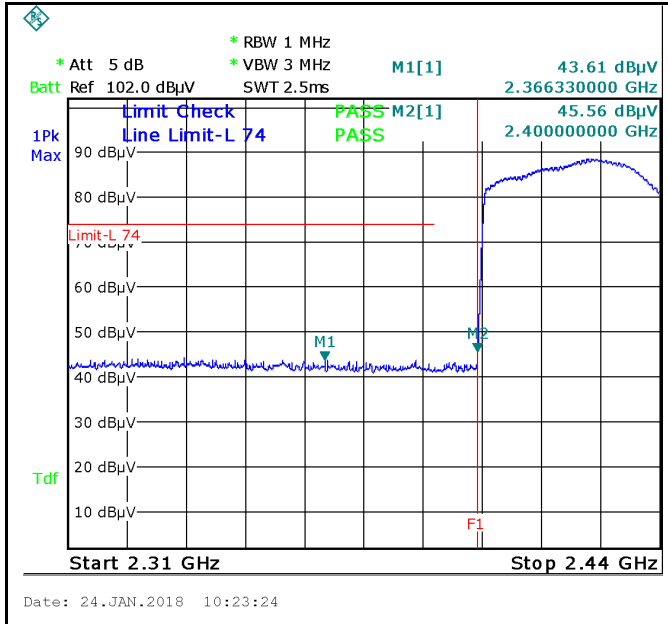
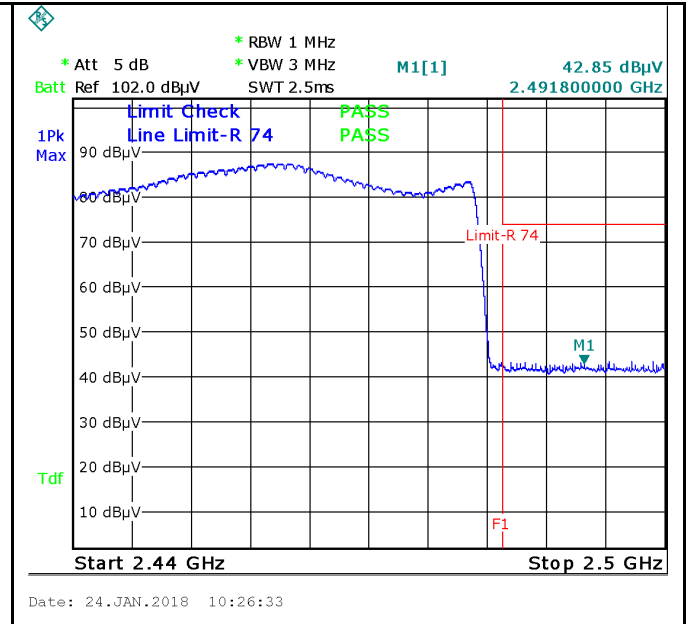
 <p>* RBW 1 MHz * Att 5 dB * VBW 3 MHz Batt Ref 102.0 dBµV SWT 2.5ms M1[1] 43.61 dBµV 2.366330000 GHz 45.56 dBµV 2.400000000 GHz Limit Check Line Limit-L 74 PASS M2[1] PASS 1Pk Max 90 dBµV Limit-L 74 M1 M2 Tdf 10 dBµV Start 2.31 GHz Stop 2.44 GHz Date: 24.JAN.2018 10:23:24</p>	 <p>* RBW 1 MHz * Att 5 dB * VBW 3 MHz Batt Ref 102.0 dBµV SWT 2.5ms M1[1] 42.85 dBµV 2.491800000 GHz Limit Check Line Limit-R 74 PASS PASS 1Pk Max 90 dBµV Limit-R 74 M1 Tdf 10 dBµV Start 2.44 GHz Stop 2.5 GHz Date: 24.JAN.2018 10:26:33</p>
<p>GFSK-Hopping Left Side-PK Note: F1 is frequency 2400MHz</p>	<p>GFSK-Hopping Right Side-PK Note: F1 is frequency 2483.5MHz</p>
<p>Note: (no need if PK value less than the AV limit)</p>	<p>Note: (no need if PK value less than the AV limit)</p>
<p>GFSK-Hopping Left Side-AV</p>	<p>GFSK-Hopping Right Side-AV</p>

Note: Both Horizontal and vertical polarities were investigated.

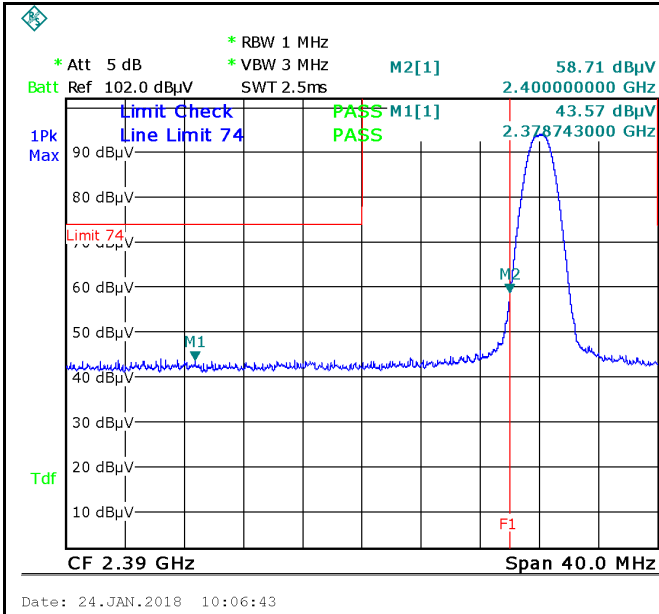

GFSK-Left Side-PK

Note: F1 is frequency 2400MHz

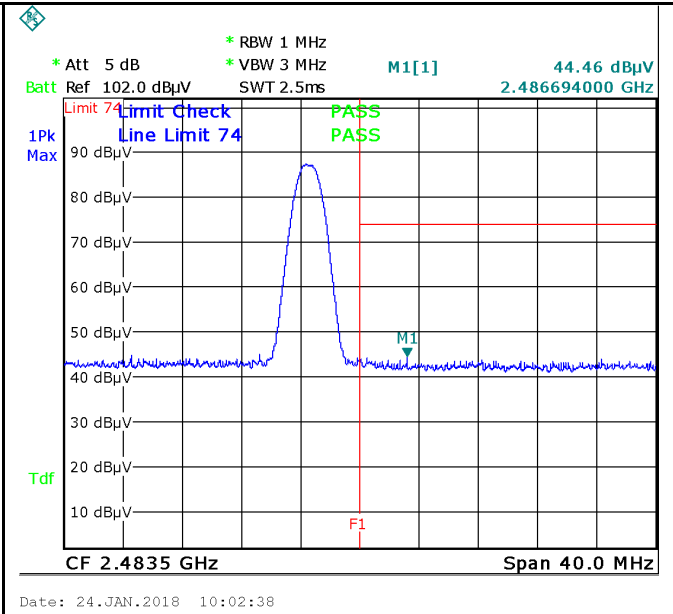

GFSK-Right Side-PK

Note: F1 is frequency 2483.5MHz

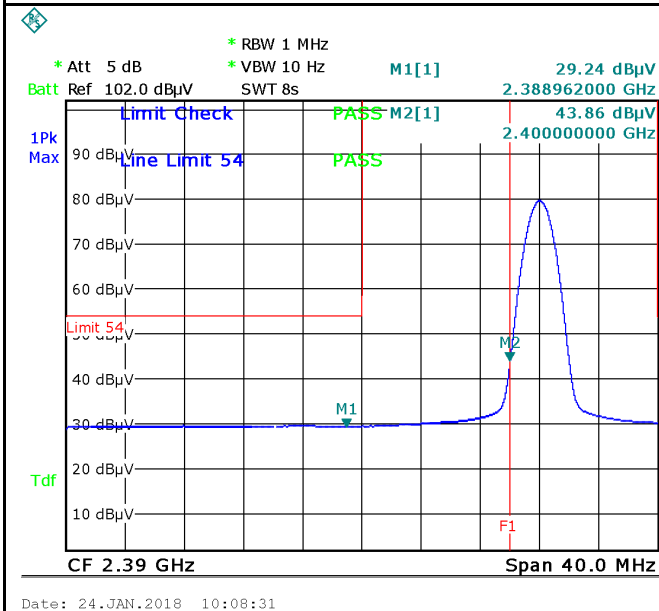

GFSK-Left Side-AV

Note: (no need if PK value less than the AV limit)

GFSK-Right Side-AV

Note: Both Horizontal and vertical polarities were investigated.

**$\pi$  / 4 DQPSK Mode:**

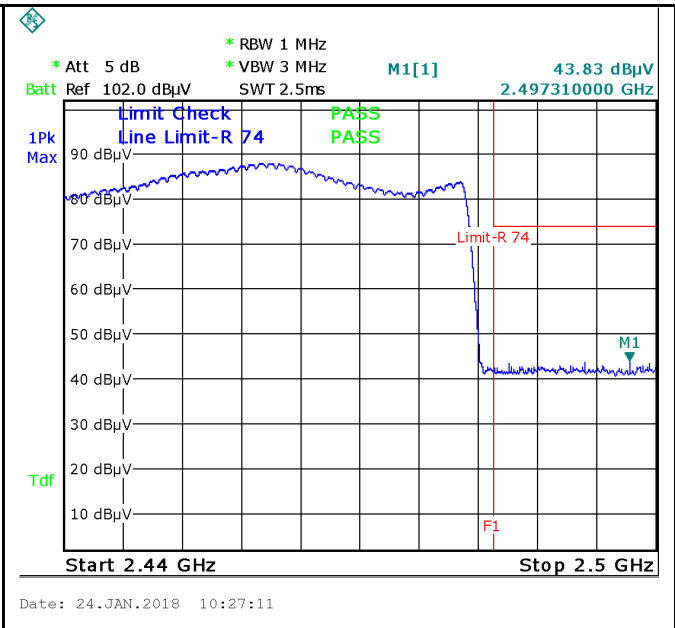
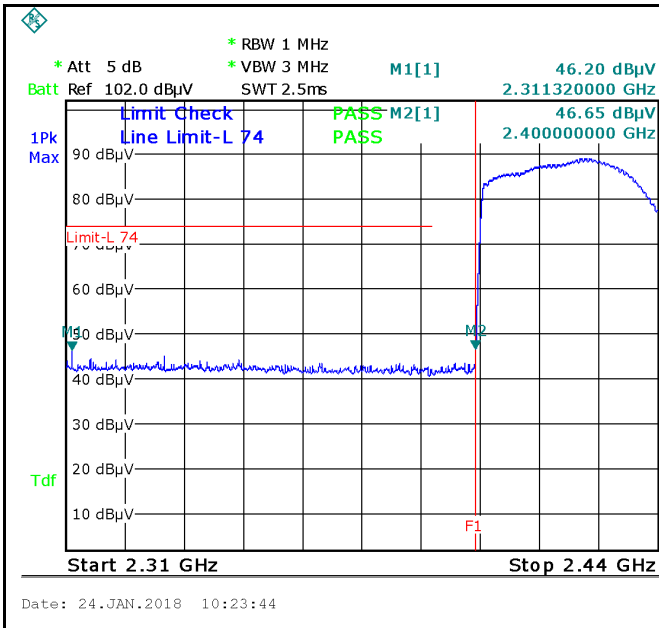

**$\pi$  / 4 DQPSK-Hopping Left Side-PK**  
**Note: F1 is frequency 2400MHz**

**$\pi$  / 4 DQPSK-Hopping Right Side-PK**  
**Note: F1 is frequency 2483.5MHz**

Note: (no need if PK value less than the AV limit)

Note: (no need if PK value less than the AV limit)

**$\pi$  / 4 DQPSK-Hopping Left-AV**

**$\pi$  / 4 DQPSK-Hopping Right-AV**

Note: Both Horizontal and vertical polarities were investigated.



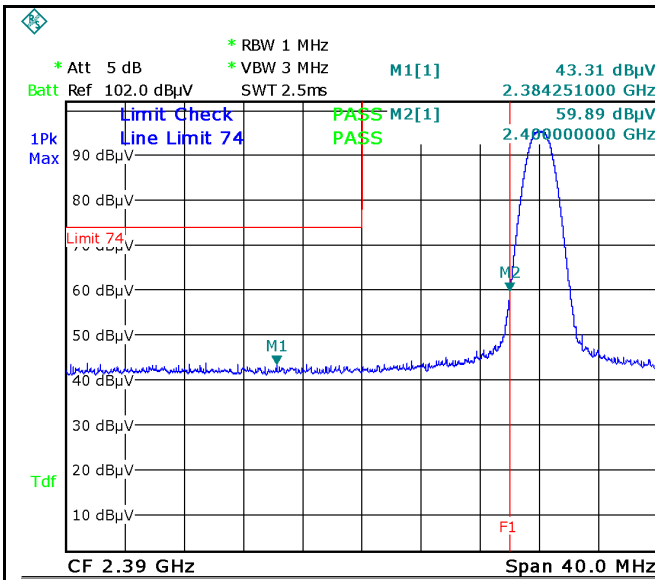

Date: 24.JAN.2018 10:07:02

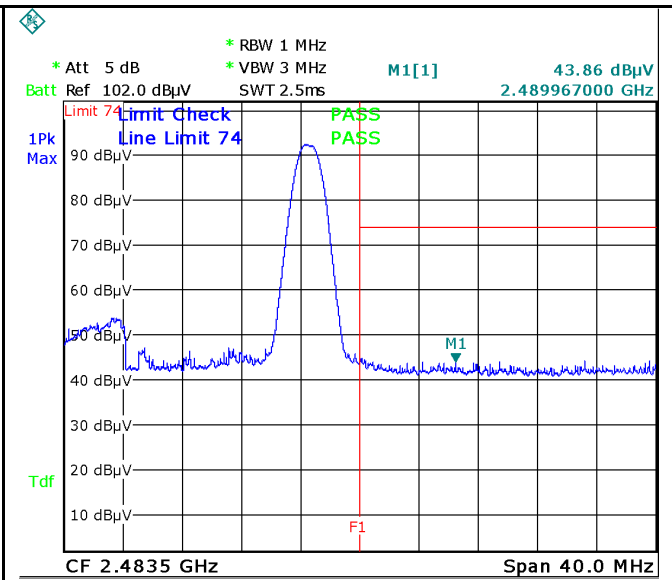

Date: 24.JAN.2018 10:02:59

$\pi$  / 4 DQPSK-Left Side-PK

Note: F1 is frequency 2400MHz

$\pi$  / 4 DQPSK-Right Side-PK

Note: F1 is frequency 2483.5MHz

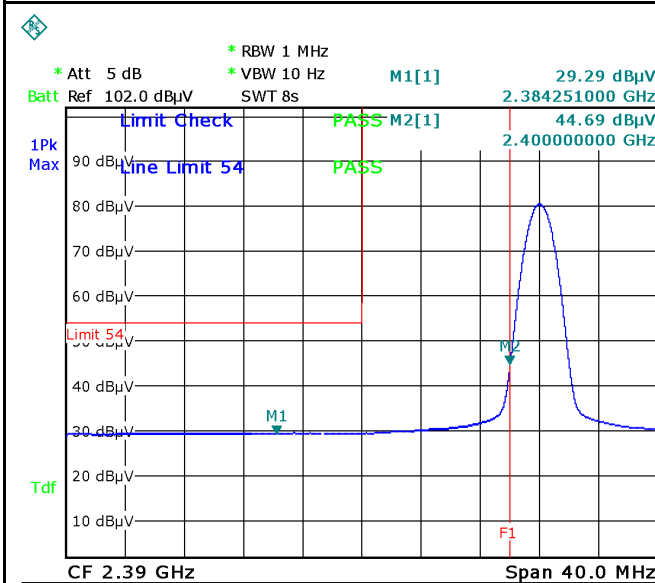

Date: 24.JAN.2018 10:09:00

Note: (no need if PK value less than the AV limit)

$\pi$  / 4 DQPSK-Left Side-AV

$\pi$  / 4 DQPSK-Right Side-AV

Note: Both Horizontal and vertical polarities were investigated.

**8-DPSK Mode:**

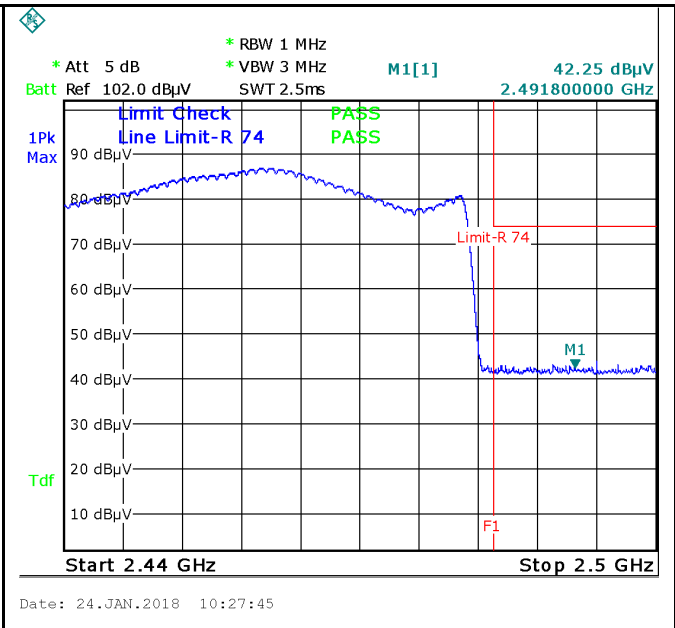
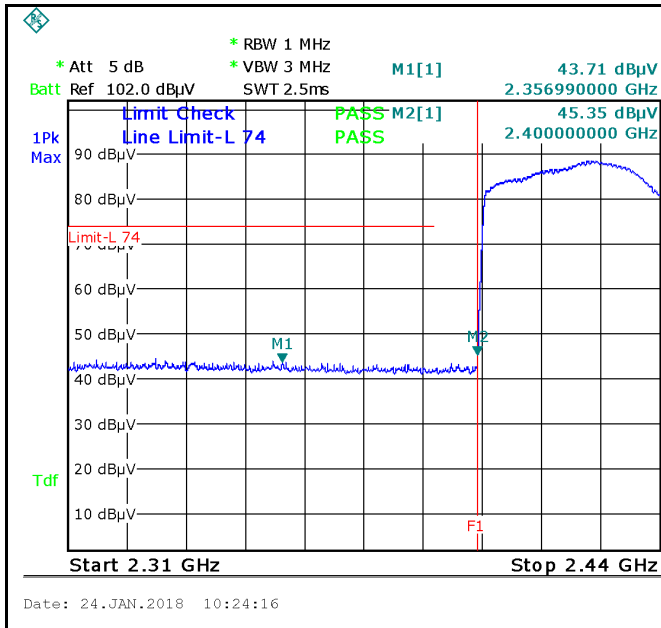

8DPSK-Hopping Left Side-PK

Note: F1 is frequency 2400MHz

8DPSK-Hopping Right Side-PK

Note: F1 is frequency 2483.5MHz

Note: (no need if PK value less than the AV limit)

Note: (no need if PK value less than the AV limit)

8DPSK-Hopping Left-AV

8DPSK-Hopping Right-AV

Note: Both Horizontal and vertical polarities were investigated.

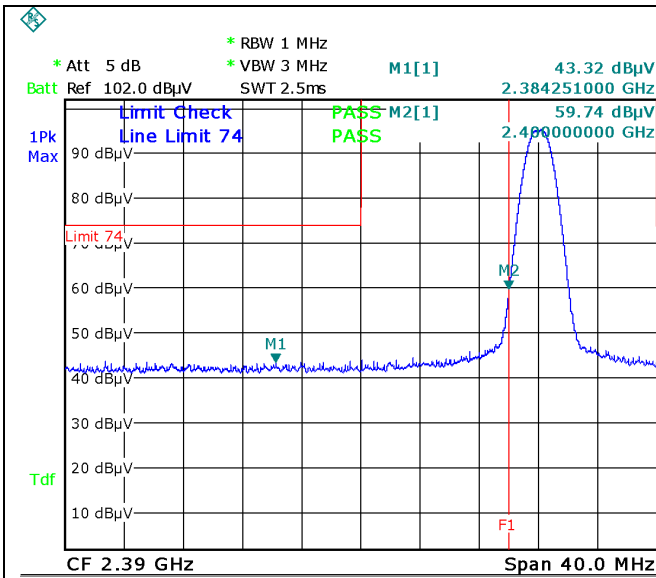

Date: 24.JAN.2018 10:07:41

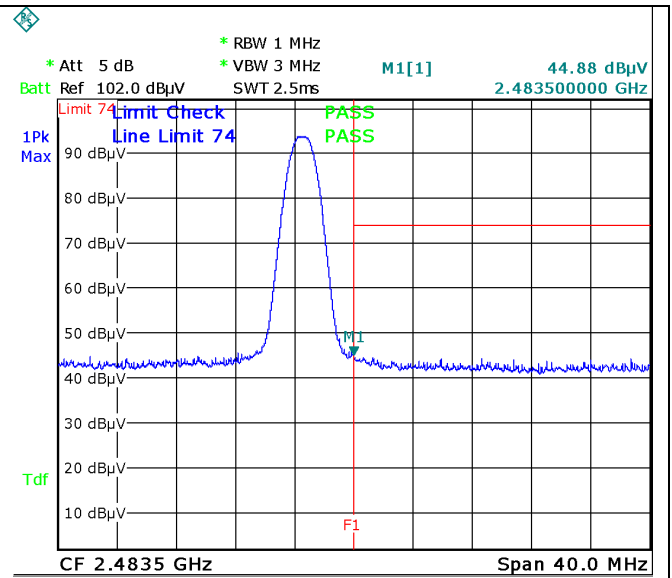

Date: 24.JAN.2018 10:04:15

8DPSK-Left Side-PK

Note: F1 is frequency 2400MHz

8DPSK-Right Side-PK

Note: F1 is frequency 2483.5MHz

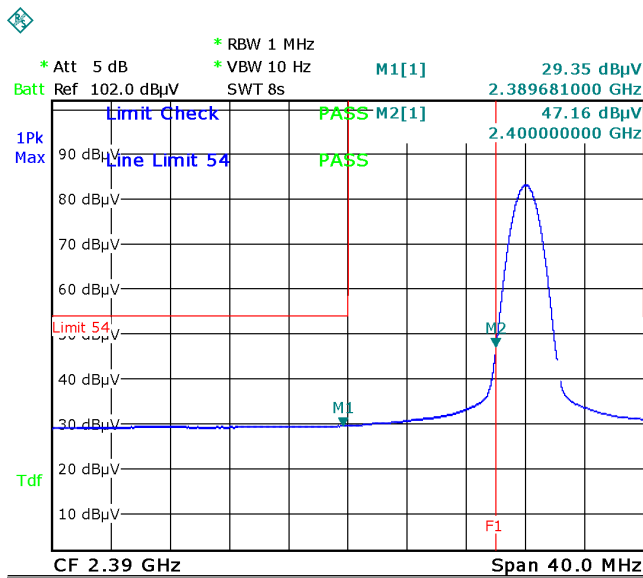

Date: 24.JAN.2018 10:09:31

Note: (no need if PK value less than the AV limit)

8DPSK-Left Side-AV

8DPSK-Right Side-AV

Note: Both Horizontal and vertical polarities were investigated.

## 6.8 AC Power Line Conducted Emissions

Temperature	25 °C
Relative Humidity	55%
Atmospheric Pressure	1017mbar
Test date :	January 23, 2018
Tested By :	Aarron Liang

### Requirement(s):

Spec	Item	Requirement	Applicable														
47CFR§15.207, RSS210 (A8.1)	a)	For Low-power radio-frequency devices that is designed to be connected to the public utility (AC) power line, the radio frequency voltage that is conducted back onto the AC power line on any frequency or frequencies, within the band 150 kHz to 30 MHz, shall not exceed the limits in the following table, as measured using a 50 [mu]H/50 ohms line impedance stabilization network (LISN). The lower limit applies at the boundary between the frequencies ranges.	<input checked="" type="checkbox"/>														
		<table border="1"> <thead> <tr> <th rowspan="2">Frequency ranges (MHz)</th> <th colspan="2">Limit (dBµV)</th> </tr> <tr> <th>QP</th> <th>Average</th> </tr> </thead> <tbody> <tr> <td>0.15 ~ 0.5</td> <td>66 – 56</td> <td>56 – 46</td> </tr> <tr> <td>0.5 ~ 5</td> <td>56</td> <td>46</td> </tr> <tr> <td>5 ~ 30</td> <td>60</td> <td>50</td> </tr> </tbody> </table>		Frequency ranges (MHz)	Limit (dBµV)		QP	Average	0.15 ~ 0.5	66 – 56	56 – 46	0.5 ~ 5	56	46	5 ~ 30	60	50
		Frequency ranges (MHz)			Limit (dBµV)												
				QP	Average												
0.15 ~ 0.5	66 – 56	56 – 46															
0.5 ~ 5	56	46															
5 ~ 30	60	50															

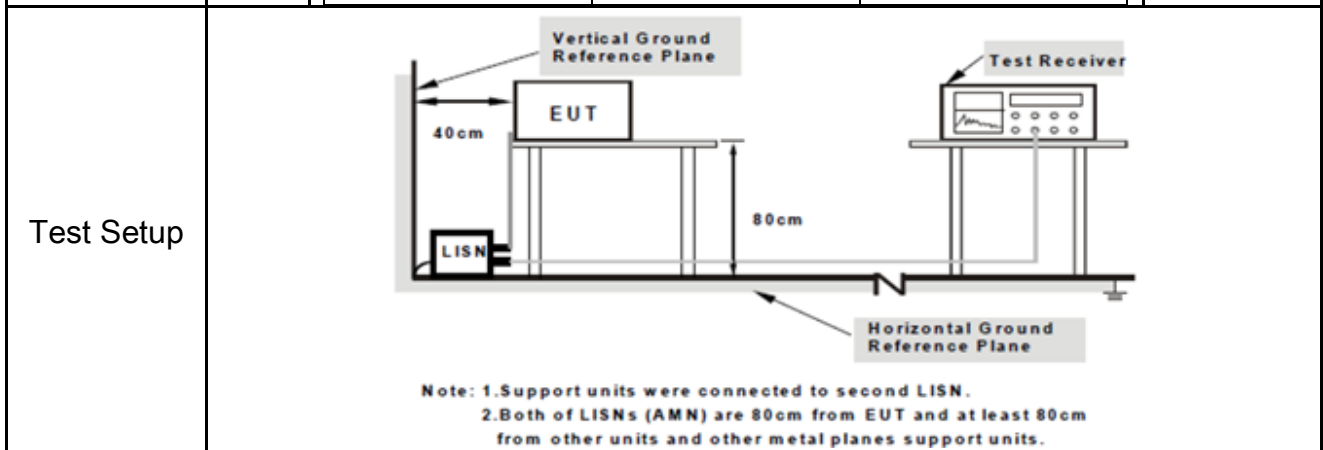

Procedure	<ol style="list-style-type: none"> <li>The EUT and supporting equipment were set up in accordance with the requirements of the standard on top of a 1.5m x 1m x 0.8m high, non-metallic table.</li> <li>The power supply for the EUT was fed through a 50W/50mH EUT LISN, connected to filtered mains.</li> <li>The RF OUT of the EUT LISN was connected to the EMI test receiver via a low-loss</li> </ol>
-----------	---

	<p>coaxial cable.</p> <ol style="list-style-type: none"> <li>4. All other supporting equipment were powered separately from another main supply.</li> <li>5. The EUT was switched on and allowed to warm up to its normal operating condition.</li> <li>6. A scan was made on the NEUTRAL line (for AC mains) or Earth line (for DC power) over the required frequency range using an EMI test receiver.</li> <li>7. High peaks, relative to the limit line, The EMI test receiver was then tuned to the selected frequencies and the necessary measurements made with a receiver bandwidth setting of 10 kHz.</li> <li>8. Step 7 was then repeated for the LIVE line (for AC mains) or DC line (for DC power).</li> </ol>
Remark	
Result	<input checked="" type="checkbox"/> Pass <input type="checkbox"/> Fail

Test Data  Yes  N/A

Test Plot  Yes (See below)  N/A

<b>Test Mode:</b>	<b>Bluetooth Mode</b>
-------------------	-----------------------

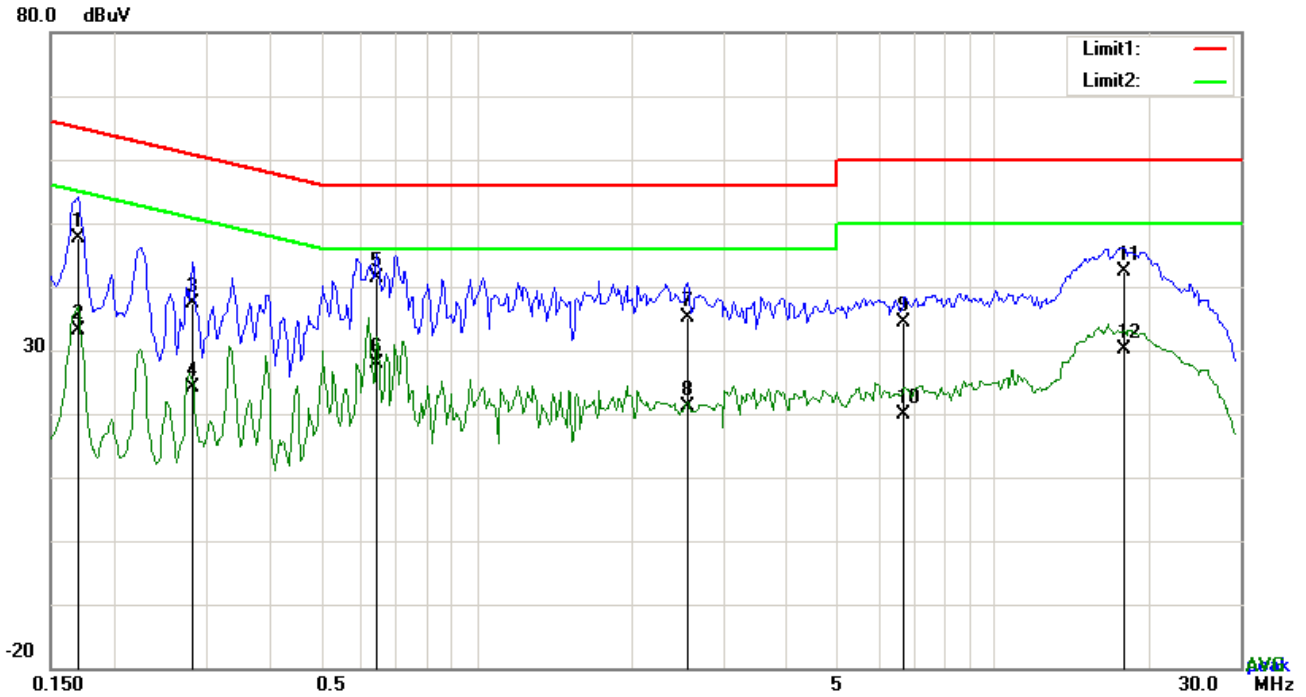

**Test Data**

**Phase Line Plot at 120Vac, 60Hz**

No.	P/L	Frequency	Reading	Detector	Corrected	Result	Limit	Margin
		(MHz)	(dBuV)		(dB)	(dBuV)	(dBuV)	(dB)
1	L1	0.1695	37.69	QP	10.03	47.72	64.98	-17.26
2	L1	0.1695	23.05	AVG	10.03	33.08	54.98	-21.90
3	L1	0.2826	27.31	QP	10.03	37.34	60.74	-23.40
4	L1	0.2826	14.05	AVG	10.03	24.08	50.74	-26.66
5	L1	0.6414	31.47	QP	10.03	41.50	56.00	-14.50
6	L1	0.6414	17.93	AVG	10.03	27.96	46.00	-18.04
7	L1	2.5563	25.01	QP	10.05	35.06	56.00	-20.94
8	L1	2.5563	11.19	AVG	10.05	21.24	46.00	-24.76
9	L1	6.7323	24.28	QP	10.10	34.38	60.00	-25.62
10	L1	6.7323	9.79	AVG	10.10	19.89	50.00	-30.11
11	L1	17.8707	32.20	QP	10.27	42.47	60.00	-17.53
12	L1	17.8707	19.88	AVG	10.27	30.15	50.00	-19.85

<b>Test Mode:</b>	<b>Bluetooth Mode</b>
-------------------	-----------------------

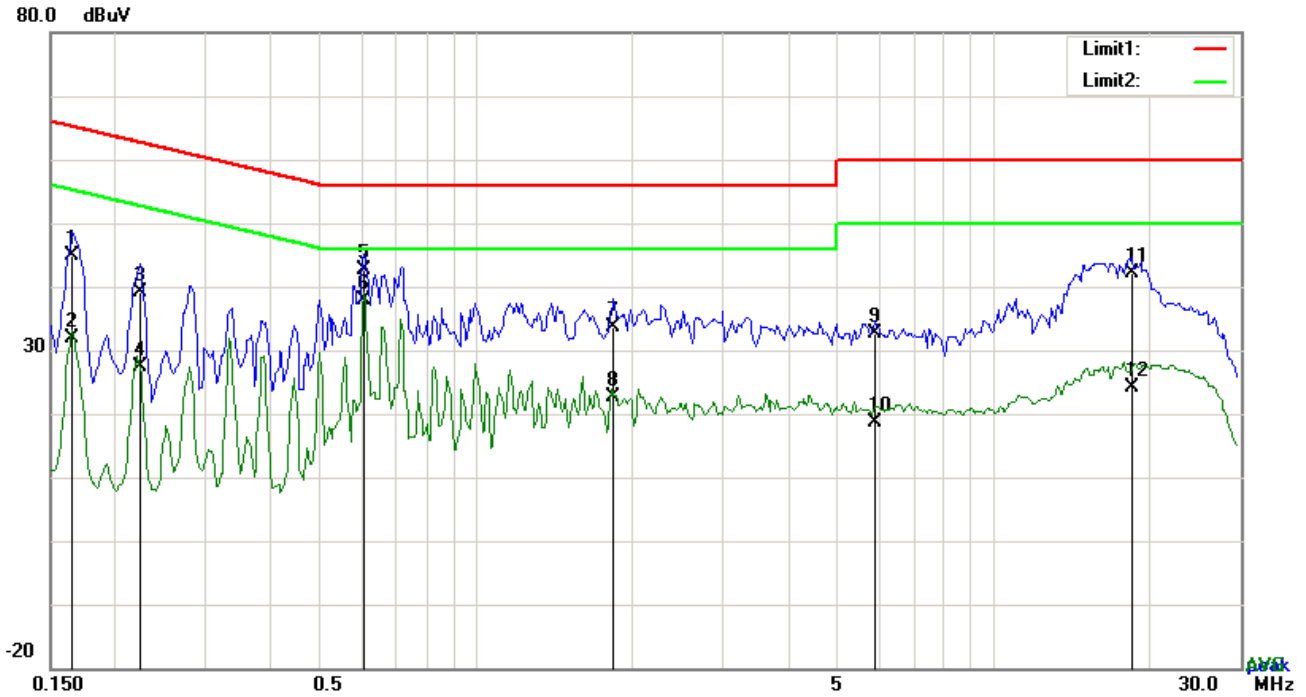

**Test Data**

**Phase Neutral Plot at 120Vac, 60Hz**

No.	P/L	Frequency	Reading	Detector	Corrected	Result	Limit	Margin
		(MHz)	(dBuV)		(dB)	(dBuV)	(dBuV)	(dB)
1	N	0.1656	34.88	QP	10.02	44.90	65.18	-20.28
2	N	0.1656	21.98	AVG	10.02	32.00	55.18	-23.18
3	N	0.2241	29.03	QP	10.02	39.05	62.67	-23.62
4	N	0.2241	17.43	AVG	10.02	27.45	52.67	-25.22
5	N	0.6063	32.56	QP	10.02	42.58	56.00	-13.42
6	N	0.6063	27.95	AVG	10.02	37.97	46.00	-8.03
7	N	1.8387	23.48	QP	10.04	33.52	56.00	-22.48
8	N	1.8387	12.69	AVG	10.04	22.73	46.00	-23.27
9	N	5.8899	22.54	QP	10.08	32.62	60.00	-27.38
10	N	5.8899	8.66	AVG	10.08	18.74	50.00	-31.26
11	N	18.5025	31.99	QP	10.24	42.23	60.00	-17.77
12	N	18.5025	13.95	AVG	10.24	24.19	50.00	-25.81

<b>Test Mode:</b>	<b>Bluetooth Mode</b>
-------------------	-----------------------

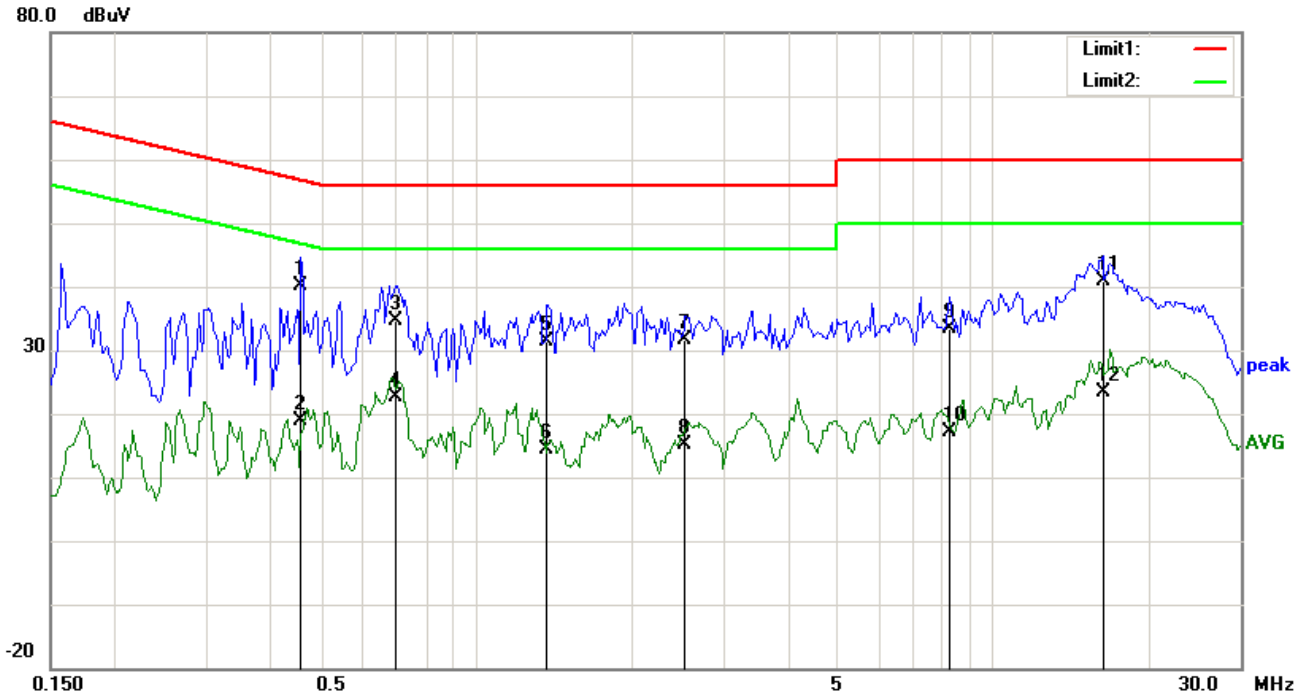

**Test Data**

**Phase Line Plot at 240Vac, 60Hz**

No.	P/L	Frequency	Reading	Detector	Corrected	Result	Limit	Margin
		(MHz)	(dBuV)		(dB)	(dBuV)	(dBuV)	(dB)
1	L1	0.4581	30.00	QP	10.02	40.02	56.73	-16.71
2	L1	0.4581	8.95	AVG	10.02	18.97	46.73	-27.76
3	L1	0.6999	24.73	QP	10.02	34.75	56.00	-21.25
4	L1	0.6999	12.73	AVG	10.02	22.75	46.00	-23.25
5	L1	1.3707	21.29	QP	10.03	31.32	56.00	-24.68
6	L1	1.3707	4.30	AVG	10.03	14.33	46.00	-31.67
7	L1	2.5329	21.57	QP	10.05	31.62	56.00	-24.38
8	L1	2.5329	5.03	AVG	10.05	15.08	46.00	-30.92
9	L1	8.1948	23.25	QP	10.11	33.36	60.00	-26.64
10	L1	8.1948	7.06	AVG	10.11	17.17	50.00	-32.83
11	L1	16.3107	30.62	QP	10.22	40.84	60.00	-19.16
12	L1	16.3107	13.07	AVG	10.22	23.29	50.00	-26.71



<b>Test Mode:</b>	<b>Bluetooth Mode</b>
-------------------	-----------------------

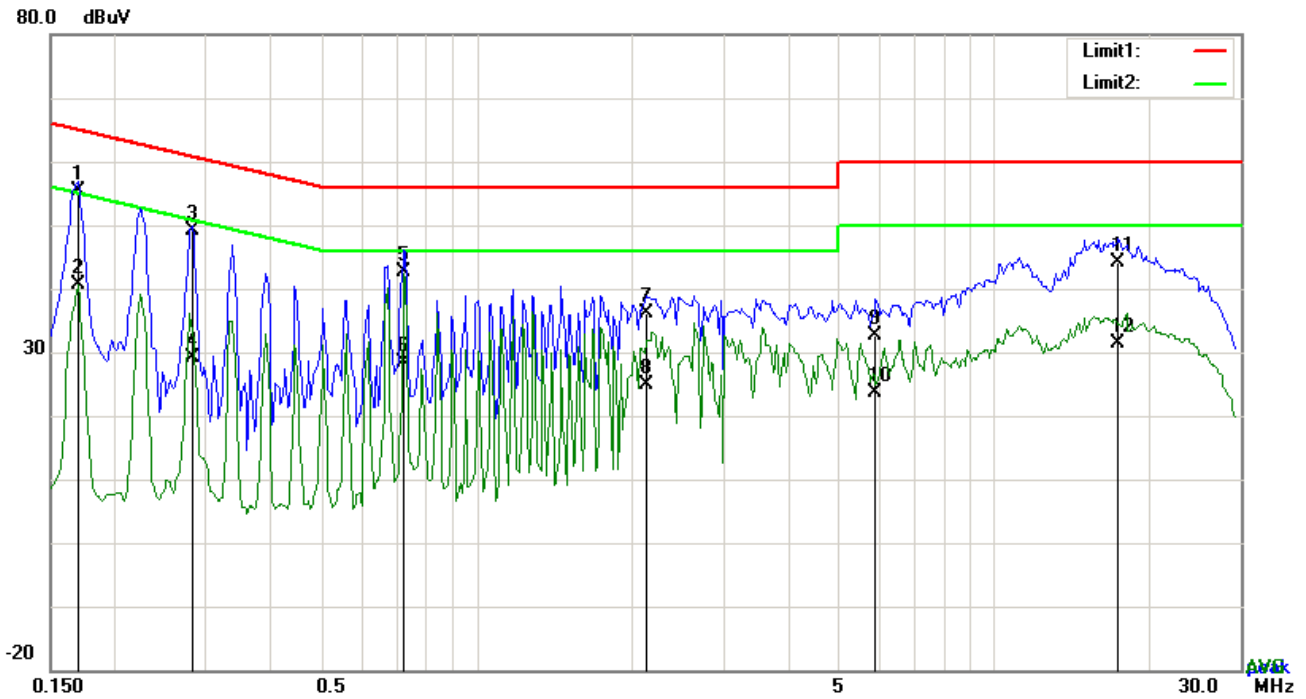

**Test Data**

**Phase Neutral Plot at 240Vac, 60Hz**

No.	P/L	Frequency	Reading	Detector	Corrected	Result	Limit	Margin
		(MHz)	(dBuV)		(dB)	(dBuV)	(dBuV)	(dB)
1	N	0.1695	45.27	QP	10.03	55.30	64.98	-9.68
2	N	0.1695	30.54	AVG	10.03	40.57	54.98	-14.41
3	N	0.2826	39.19	QP	10.03	49.22	60.74	-11.52
4	N	0.2826	19.18	AVG	10.03	29.21	50.74	-21.53
5	N	0.7272	32.67	QP	10.03	42.70	56.00	-13.30
6	N	0.7272	18.41	AVG	10.03	28.44	46.00	-17.56
7	N	2.1234	26.12	QP	10.04	36.16	56.00	-19.84
8	N	2.1234	14.85	AVG	10.04	24.89	46.00	-21.11
9	N	5.9172	22.47	QP	10.09	32.56	60.00	-27.44
10	N	5.9172	13.56	AVG	10.09	23.65	50.00	-26.35
11	N	17.4339	33.96	QP	10.26	44.22	60.00	-15.78
12	N	17.4339	21.23	AVG	10.26	31.49	50.00	-18.51

## 6.9 Radiated Emissions & Restricted Band

Temperature	24 °C
Relative Humidity	55%
Atmospheric Pressure	1013mbar
Test date :	February 05, 2018
Tested By :	Aarron Liang

### Requirement(s):

Spec	Item	Requirement	Applicable																
47CFR§15.205, §15.209, §15.247(d)	a)	Except higher limit as specified elsewhere in other section, the emissions from the low-power radio-frequency devices shall not exceed the field strength levels specified in the following table and the level of any unwanted emissions shall not exceed the level of the fundamental emission. The tighter limit applies at the band edges	<input checked="" type="checkbox"/>																
		<table border="1" style="width: 100%;"> <thead> <tr> <th>Frequency range (MHz)</th> <th>Field Strength (<math>\mu\text{V}/\text{m}</math>)</th> </tr> </thead> <tbody> <tr> <td>0.009~0.490</td> <td>2400/F(KHz)</td> </tr> <tr> <td>0.490~1.705</td> <td>24000/F(KHz)</td> </tr> <tr> <td>1.705~30.0</td> <td>30</td> </tr> <tr> <td>30 – 88</td> <td>100</td> </tr> <tr> <td>88 – 216</td> <td>150</td> </tr> <tr> <td>216 960</td> <td>200</td> </tr> <tr> <td>Above 960</td> <td>500</td> </tr> </tbody> </table>		Frequency range (MHz)	Field Strength ( $\mu\text{V}/\text{m}$ )	0.009~0.490	2400/F(KHz)	0.490~1.705	24000/F(KHz)	1.705~30.0	30	30 – 88	100	88 – 216	150	216 960	200	Above 960	500
		Frequency range (MHz)		Field Strength ( $\mu\text{V}/\text{m}$ )															
		0.009~0.490		2400/F(KHz)															
		0.490~1.705		24000/F(KHz)															
		1.705~30.0		30															
		30 – 88		100															
		88 – 216		150															
216 960	200																		
Above 960	500																		

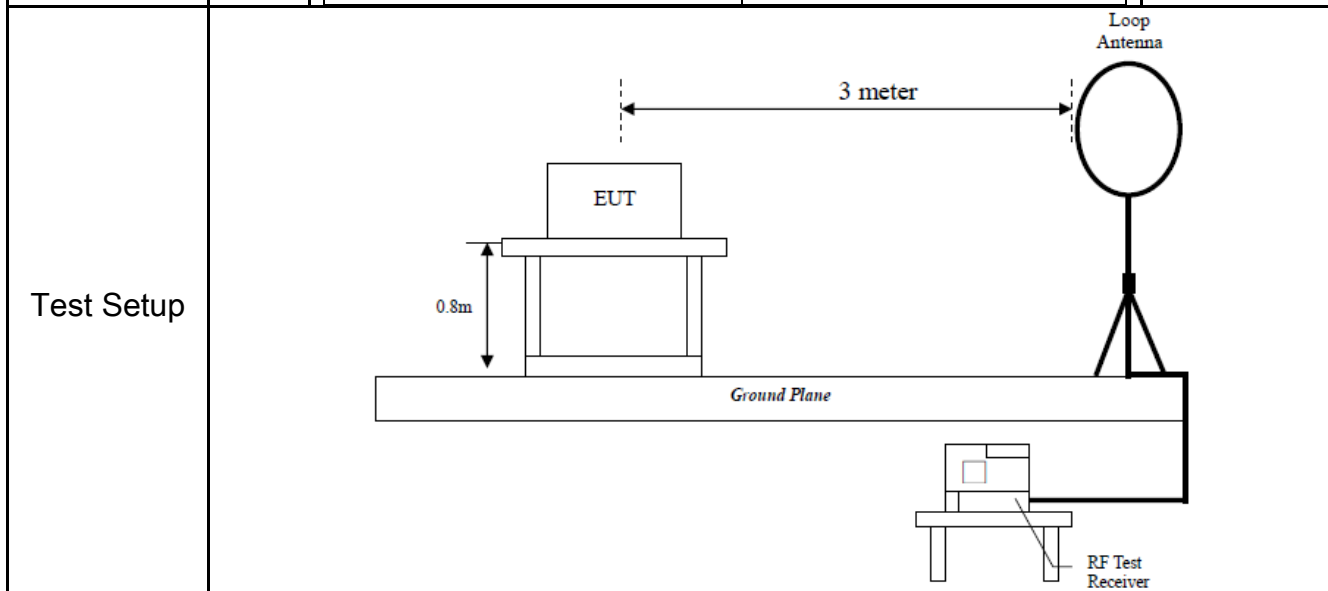

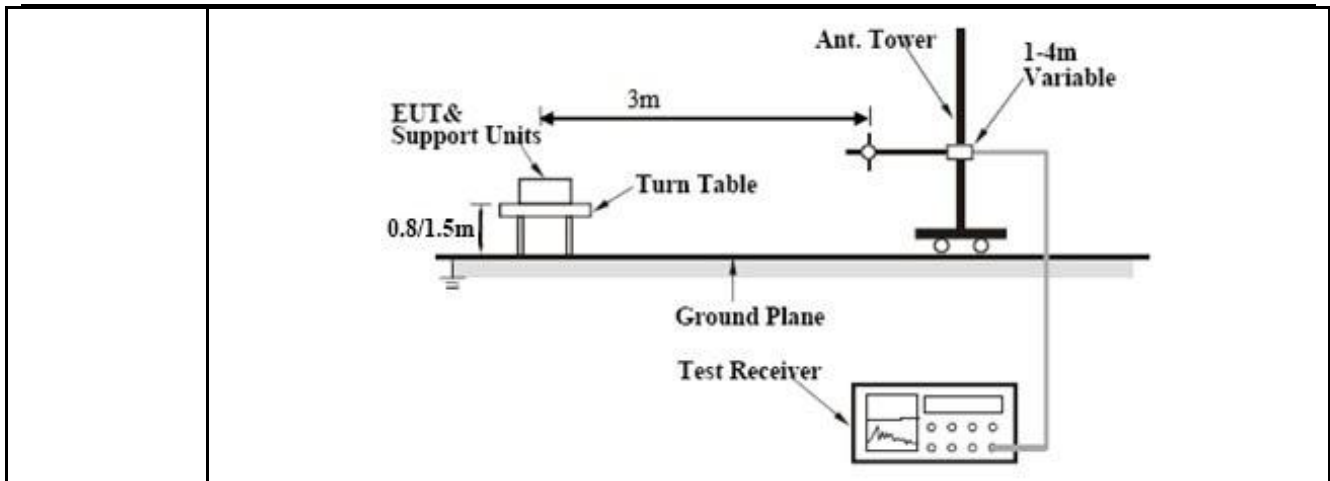

**Procedure**

- The EUT was switched on and allowed to warm up to its normal operating condition.
- The test was carried out at the selected frequency points obtained from the EUT characterization. Maximization of the emissions, was carried out by rotating the EUT, changing the antenna polarization, and adjusting the antenna height in the following manner:
  - Vertical or horizontal polarization (whichever gave the higher emission level over a full rotation of the EUT) was chosen.
  - The EUT was then rotated to the direction that gave the maximum emission.
  - Finally, the antenna height was adjusted to the height that gave the maximum emission.
- The resolution bandwidth and video bandwidth of test receiver/spectrum analyzer is 120 kHz for Quasi Peak detection at frequency below 1GHz.
- The resolution bandwidth of test receiver/spectrum analyzer is 1MHz and video bandwidth is 3MHz with Peak detection for Peak measurement at frequency above 1GHz.  
The resolution bandwidth of test receiver/spectrum analyzer is 1MHz and the video bandwidth is 10Hz with Peak detection for Average Measurement as below at frequency above 1GHz.
- Steps 2 and 3 were repeated for the next frequency point, until all selected frequency points were measured.

**Remark**

**Result**  Pass  Fail

**Test Data**  Yes  N/A

**Test Plot**  Yes (See below)  N/A

**Test Result:**

<b>Test Mode:</b>	Transmitting Mode
-------------------	-------------------

Frequency range: 9KHz - 30MHz

Freq. (MHz)	Detection value	Factor (dB/m)	Reading (dBuV/m)	Result (dBuV/m)	Limit@3m (dBuV/m)	Margin (dB)
--	--	--	--	--	--	>20
--	--	--	--	--	--	>20

**Note:**

The amplitude of spurious emissions which are attenuated by more than 20dB below the permissible value has no need to be reported.

Distance extrapolation factor =  $40 \log(\text{specific distance}/\text{test distance})$ (dB);

Limit line = specific limits(dBuv) + distance extrapolation factor.

**Test Mode:** Bluetooth Mode

**30MHz -1GHz**

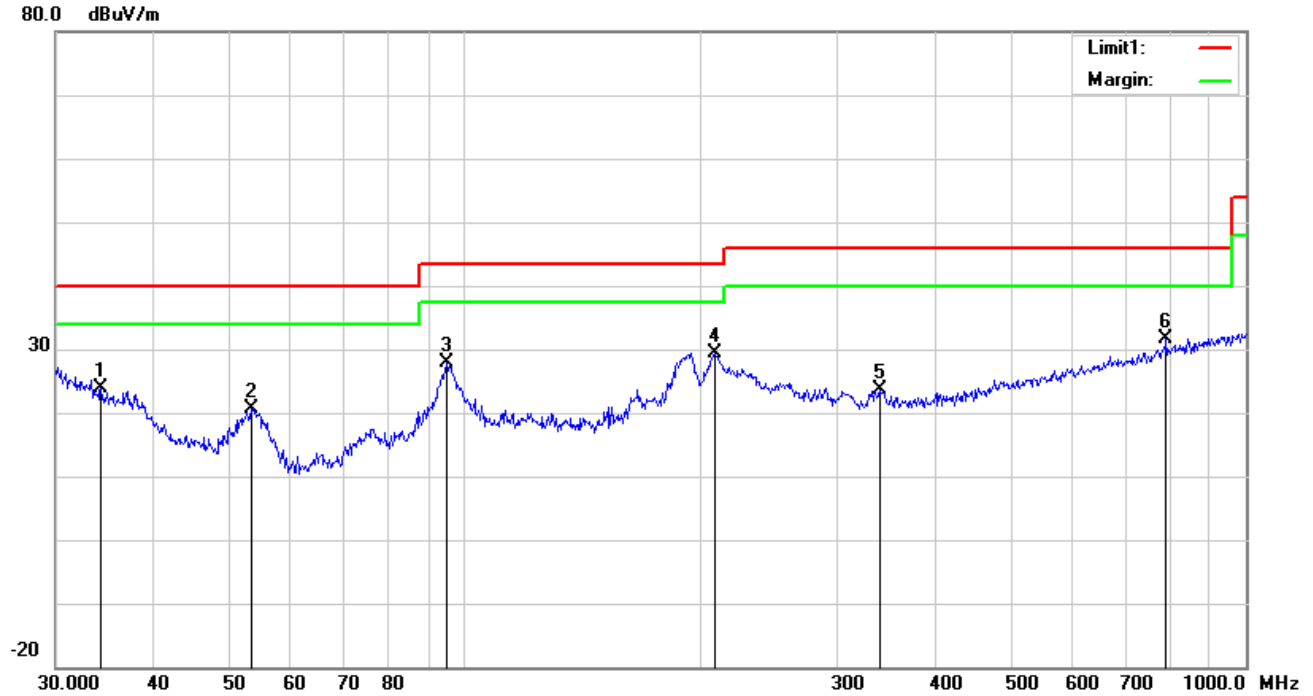

**Test Data**

**Horizontal Polarity Plot @3m**

No.	P/L	Frequency (MHz)	Reading (dBuV/m)	Detect or	Ant_F (dB/m)	PA_G (dB)	Cab_L (dB)	Result (dBuV/m)	Limit (dBuV/m)	Margin (dB)	Height (cm)	Degr ee ( )
1	H	34.2760	27.23	peak	18.11	22.25	0.74	23.83	40.00	-16.17	100	203
2	H	53.3179	34.16	peak	8.04	22.39	0.79	20.60	40.00	-19.40	100	249
3	H	95.0930	40.01	peak	9.22	22.32	0.99	27.90	43.50	-15.60	100	249
4	H	209.3129	38.12	peak	11.97	22.36	1.57	29.30	43.50	-14.20	100	291
5	H	339.5888	29.45	peak	14.43	22.18	1.99	23.69	46.00	-22.31	100	64
6	H	790.6188	28.68	peak	21.29	21.17	2.94	31.74	46.00	-14.26	100	207

### 30MHz -1GHz

80.0 dBuV/m

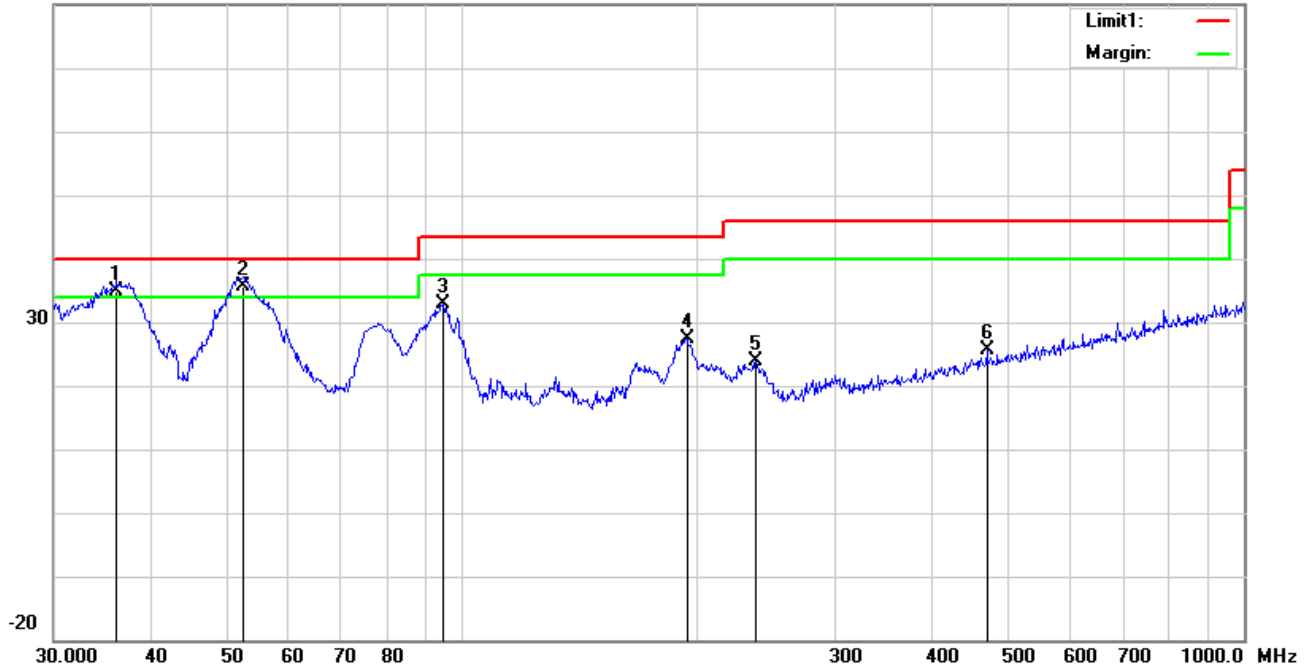

#### Test Data

#### Vertical Polarity Plot @3m

No.	P/L	Frequency (MHz)	Reading (dBuV/m)	Detect or	Ant_F (dB/m)	PA_G (dB)	Cab_L (dB)	Result (dBuV/m)	Limit (dBuV/m)	Margin (dB)	Height (cm)	Degr ee ( )
1	V	36.1272	39.66	QP	16.73	22.26	0.77	34.90	40.00	-5.10	100	320
2	V	52.3913	49.08	QP	8.14	22.39	0.79	35.62	40.00	-4.38	100	221
3	V	94.4284	45.21	peak	9.06	22.32	0.99	32.94	43.50	-10.56	100	348
4	V	193.7728	36.40	peak	11.76	22.34	1.54	27.36	43.50	-16.14	100	267
5	V	237.4760	33.02	peak	11.58	22.31	1.66	23.95	46.00	-22.05	100	148
6	V	468.8762	28.23	peak	17.08	21.87	2.24	25.68	46.00	-20.32	100	238

### Above 1GHz

<b>Test Mode:</b>	<b>Transmitting Mode</b>
-------------------	--------------------------

#### Low Channel: GFSK Mode (Worst Case) (2402 MHz)

Frequency (MHz)	S.A. Reading (dBμV)	Detector (PK/AV)	Polarity (H/V)	Ant. Factor (dB/m)	Cable Loss (dB)	Pre-Amp. Gain (dB)	Cord. Amp. (dBμV/m)	Limit (dBμV/m)	Margin (dB)
4804	49.56	AV	V	33.39	7.22	48.46	41.71	54	-12.29
4804	42.7	AV	H	33.39	7.22	48.46	34.85	54	-19.15
4804	69.47	PK	V	33.39	7.22	48.46	61.62	74	-12.38
4804	67.67	PK	H	33.39	7.22	48.46	59.82	74	-14.18
7151	39.08	AV	V	36.95	7.91	49.1	34.84	54	-19.16
7151	35.76	AV	H	36.95	7.91	49.1	31.52	54	-22.48
7151	59.2	PK	V	36.95	7.91	49.1	54.96	74	-19.04
7151	58.35	PK	H	36.95	7.91	49.1	54.11	74	-19.89

#### Middle Channel: GFSK Mode (Worst Case) (2441 MHz)

Frequency (MHz)	S.A. Reading (dBμV)	Detector (PK/AV)	Polarity (H/V)	Ant. Factor (dB/m)	Cable Loss (dB)	Pre-Amp. Gain (dB)	Cord. Amp. (dBμV/m)	Limit (dBμV/m)	Margin (dB)
4882	47.27	AV	V	33.62	7.53	48.36	40.06	54	-13.94
4882	42.65	AV	H	33.62	7.53	48.36	35.44	54	-18.56
4882	65.08	PK	V	33.62	7.53	48.36	57.87	74	-16.13
4882	62.39	PK	H	33.62	7.53	48.36	55.18	74	-18.82
10957	37.23	AV	V	39.61	11.02	47.47	40.39	54	-13.61
10957	34.01	AV	H	39.61	11.02	47.47	37.17	54	-16.83
10957	54.55	PK	V	39.61	11.02	47.47	57.71	74	-16.29
10957	55.29	PK	H	39.61	11.02	47.47	58.45	74	-15.55

**High Channel: GFSK Mode (Worst Case) (2480 MHz)**

Frequency (MHz)	S.A. Reading (dB $\mu$ V)	Detector (PK/AV)	Polarity (H/V)	Ant. Factor (dB/m)	Cable Loss (dB)	Pre-Amp. Gain (dB)	Cord. Amp. (dB $\mu$ V/m)	Limit (dB $\mu$ V/m)	Margin (dB)
4960	46.01	AV	V	33.89	7.86	48.31	39.45	54	-14.55
4960	47.35	AV	H	33.89	7.86	48.31	40.79	54	-13.21
4960	68.71	PK	V	33.89	7.86	48.31	62.15	74	-11.85
4960	62.56	PK	H	33.89	7.86	48.31	56	74	-18
17783	25.79	AV	V	41.71	16.95	46.07	38.38	54	-15.62
17783	23.31	AV	H	41.71	16.95	46.07	35.9	54	-18.1
17783	45.42	PK	V	41.71	16.95	46.07	58.01	74	-15.99
17783	47.23	PK	H	41.71	16.95	46.07	59.82	74	-14.18

**Note:**

1, The testing has been conformed to  $10 \times 2480 \text{ MHz} = 24,800 \text{ MHz}$

2, All other emissions more than 30 dB below the limit

3, X-Axis, Y-Axis and Z-Axis were investigated. The results above show only the worst case.

4, The radiated spurious test above 18GHz is subcontracted to SIEMIC (Nanjing-China) Laboratories. and found 30dB below the limit at least.



## Annex A. TEST INSTRUMENT

Instrument	Model	Serial #	Cal Date	Cal Due	In use
<b>AC Line Conducted</b>					
EMI test receiver	ESCS30	8471241027	09/15/2017	09/14/2018	<input checked="" type="checkbox"/>
Line Impedance	LI-125A	191106	09/23/2017	09/22/2018	<input checked="" type="checkbox"/>
Line Impedance	LI-125A	191107	09/23/2017	09/22/2018	<input checked="" type="checkbox"/>
ISN	ISN T800	34373	09/23/2017	09/22/2018	<input type="checkbox"/>
Transient Limiter	LIT-153	531118	08/30/2017	08/29/2018	<input type="checkbox"/>
<b>RF conducted test</b>					
Agilent ESA-E SERIES	E4407B	MY45108319	09/15/2017	09/14/2018	<input checked="" type="checkbox"/>
Power Splitter	1#	1#	08/30/2017	08/29/2018	<input checked="" type="checkbox"/>
DC Power Supply	E3640A	MY40004013	09/15/2017	09/14/2018	<input checked="" type="checkbox"/>
<b>Radiated Emissions</b>					
EMI test receiver	ESL6	100262	09/15/2017	09/14/2018	<input checked="" type="checkbox"/>
Positioning Controller	UC3000	MF780208282	11/17/2017	11/16/2018	<input checked="" type="checkbox"/>
OPT 010 AMPLIFIER (0.1-1300MHz)	8447E	2727A02430	08/30/2017	08/29/2018	<input checked="" type="checkbox"/>
Microwave Preamplifier (1 ~ 26.5GHz)	8449B	3008A02402	03/23/2017	03/22/2018	<input checked="" type="checkbox"/>
Horn Antenna	BBHA9170	3145226D1	09/27/2017	09/26/2018	<input checked="" type="checkbox"/>
Active Antenna (9kHz-30MHz)	AL-130	121031	10/12/2017	10/11/2018	<input checked="" type="checkbox"/>
Bilog Antenna (30MHz~6GHz)	JB6	A110712	09/19/2017	09/18/2018	<input checked="" type="checkbox"/>
Double Ridge Horn Antenna (1 ~18GHz)	AH-118	71283	09/22/2017	09/21/2018	<input checked="" type="checkbox"/>
Universal Radio Communication Tester	CMU200	121393	09/23/2017	09/22/2018	<input checked="" type="checkbox"/>

## Annex C. TEST SETUP AND SUPPORTING EQUIPMENT

### Annex C.ii. TEST SET UP BLOCK

#### Block Configuration Diagram for AC Line Conducted Emissions

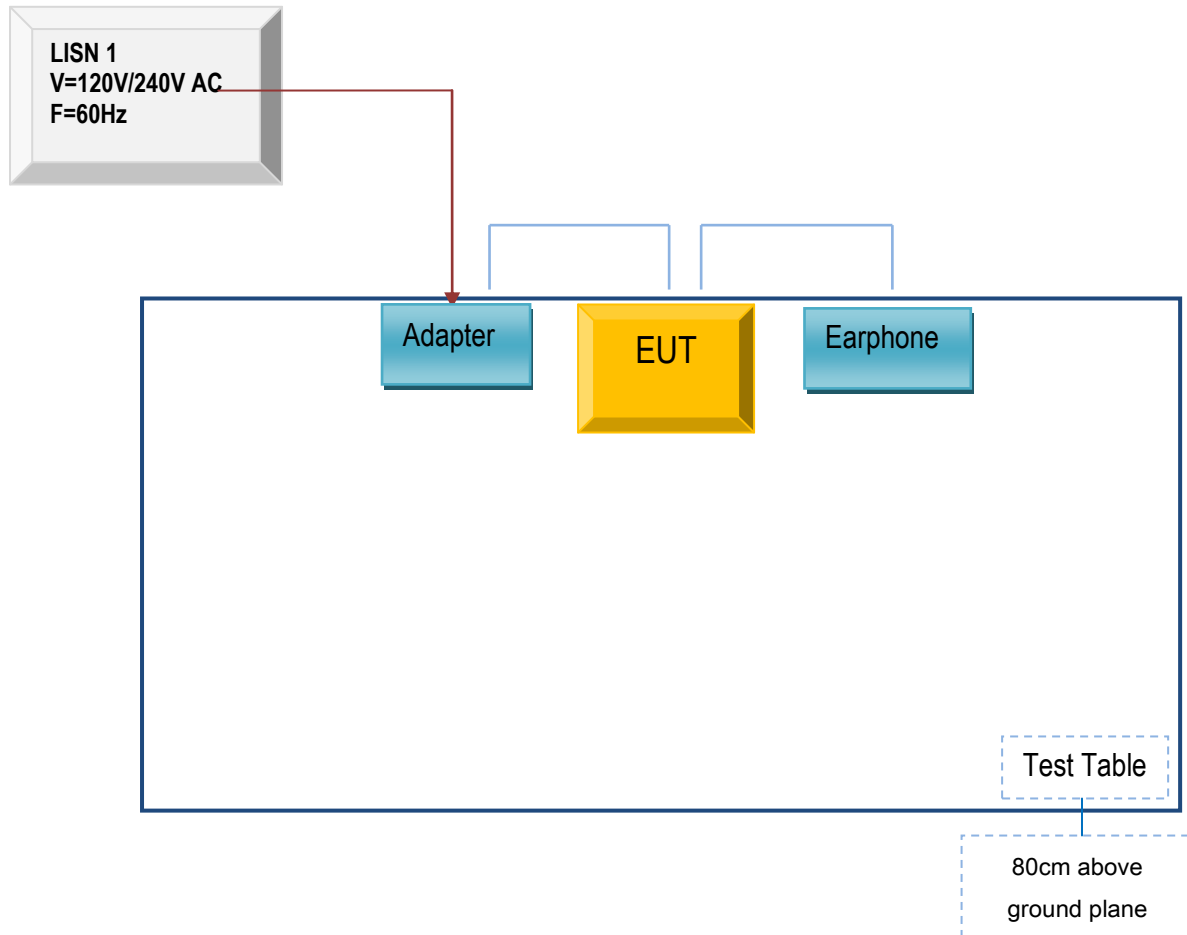

Block Configuration Diagram for Radiated Emissions ( Below 1GHz ) .

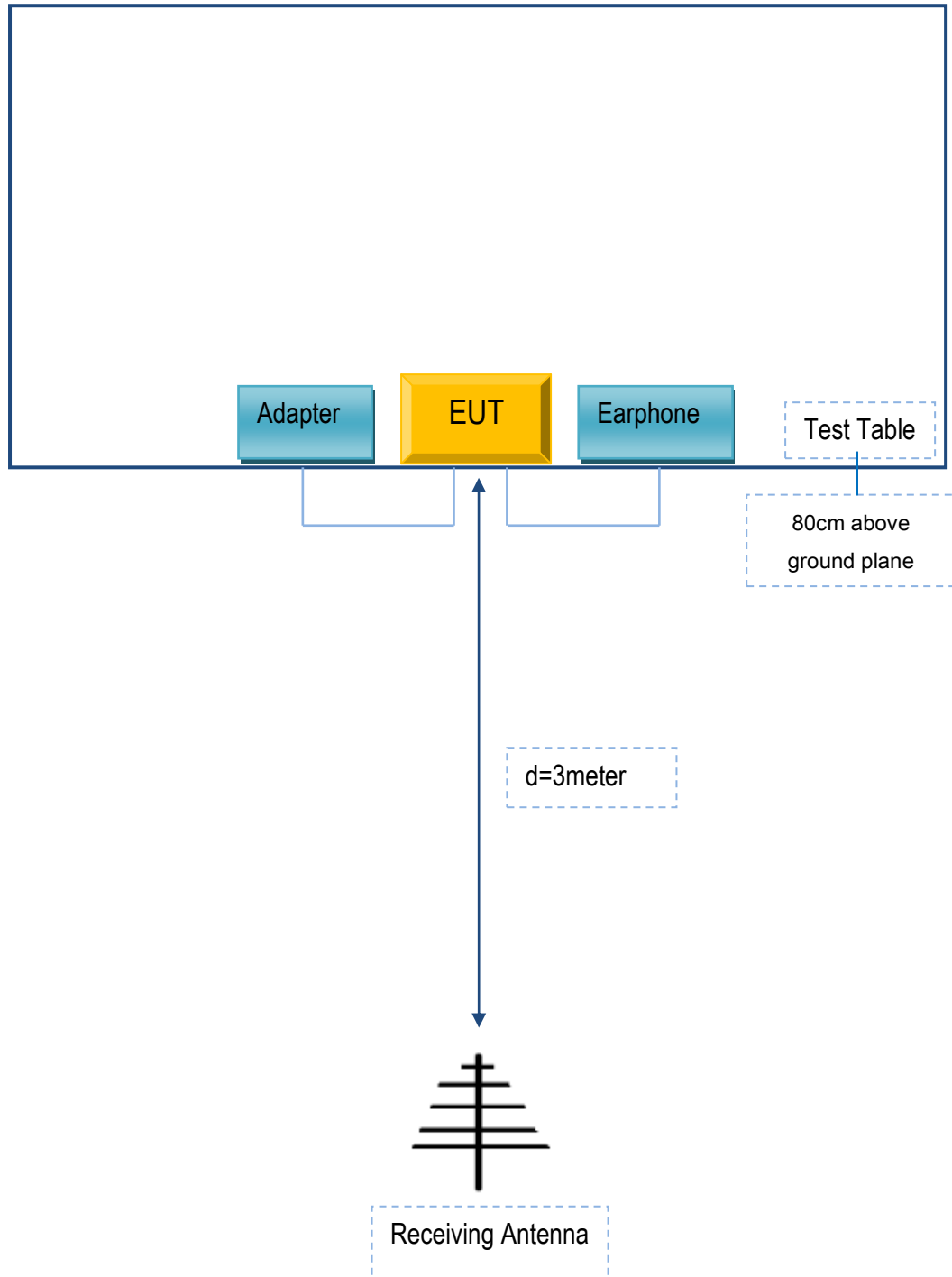

**Block Configuration Diagram for Radiated Emissions ( Above 1GHz ) .**

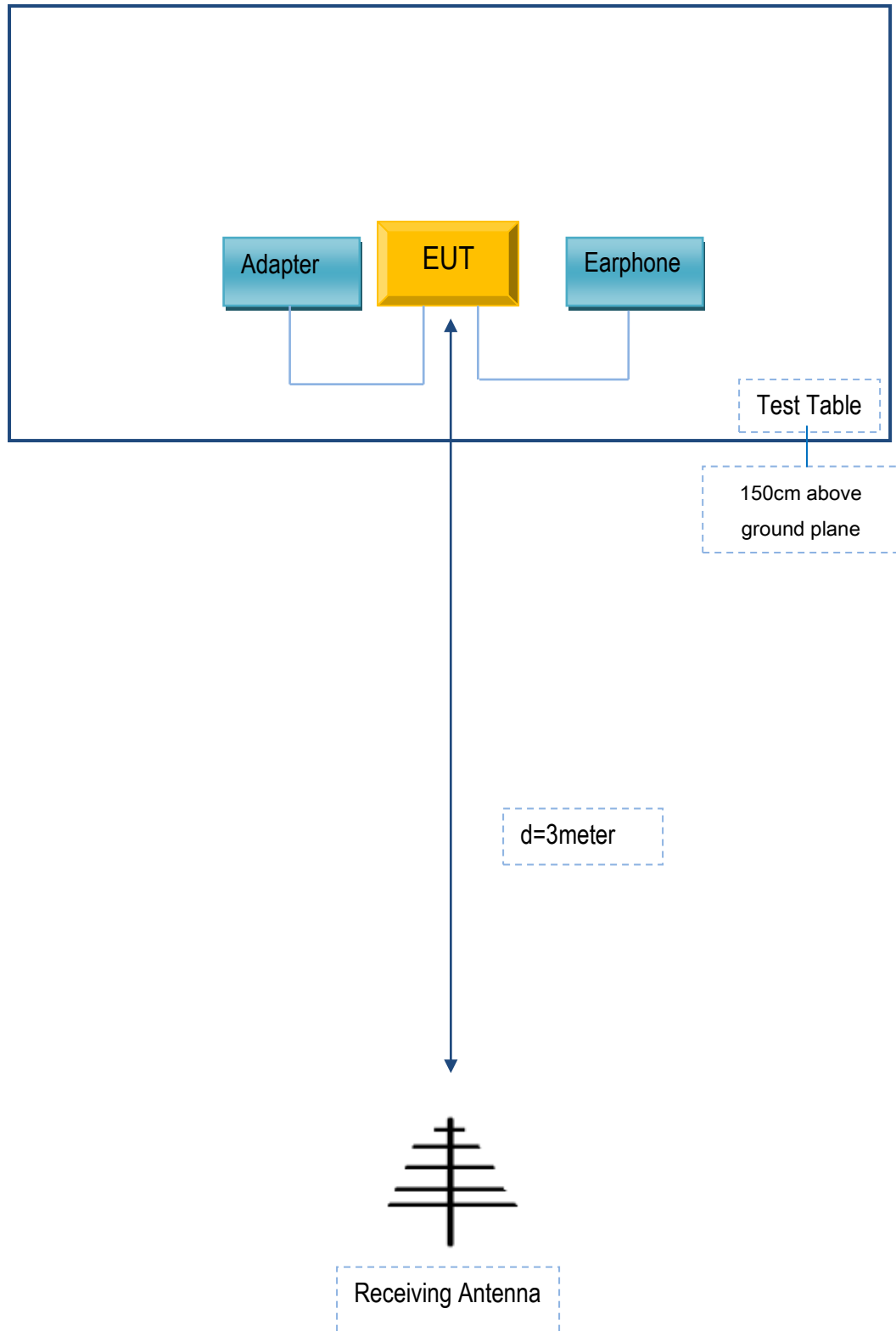

## Annex C. ii. SUPPORTING EQUIPMENT DESCRIPTION

The following is a description of supporting equipment and details of cables used with the EUT.

### Supporting Equipment:

Manufacturer	Equipment Description	Model	Serial No
TECNO MOBILE LIMITED	Adapter	A88-502000	N/A
TECNO MOBILE LIMITED	Earphone	CA7	N/A

### Supporting Cable:

Cable type	Shield Type	Ferrite Core	Length	Serial No
USB Cable	Un-shielding	No	0.8m	N/A

Test Report	18070029-FCC-R3
Page	54 of 55

## Annex D. User Manual / Block Diagram / Schematics / Partlist

Please see the attachment

Test Report	18070029-FCC-R3
Page	55 of 55

## Annex E. DECLARATION OF SIMILARITY

N/A