

LTE Band V (Part 22H)

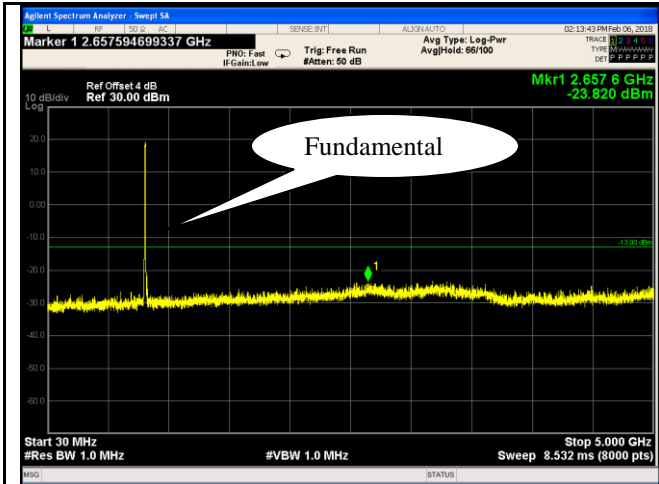

LTE Band V - Low Channel-1

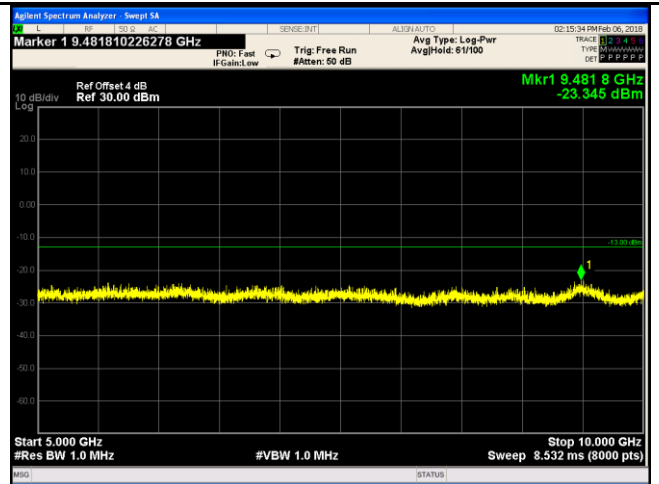

LTE Band V - Low Channel-2

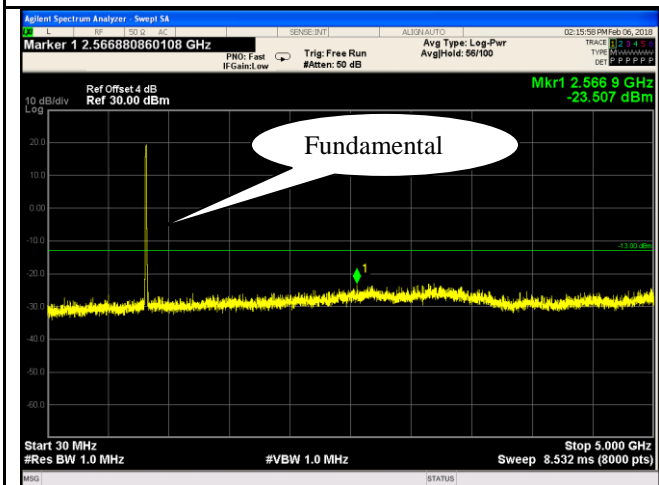

LTE Band V - Middle Channel-1

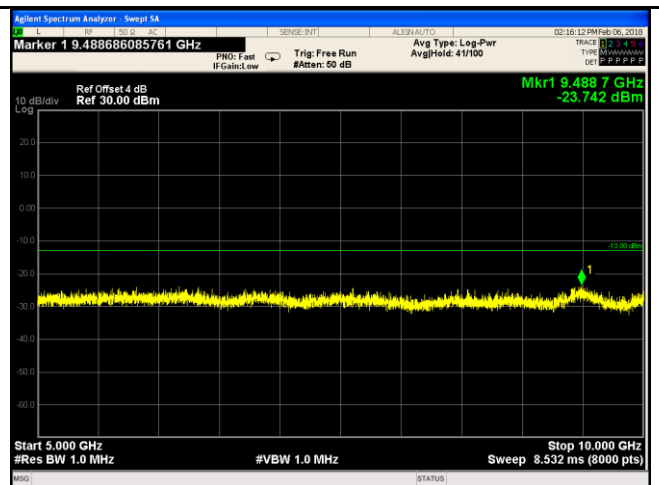

LTE Band V - Middle Channel-2

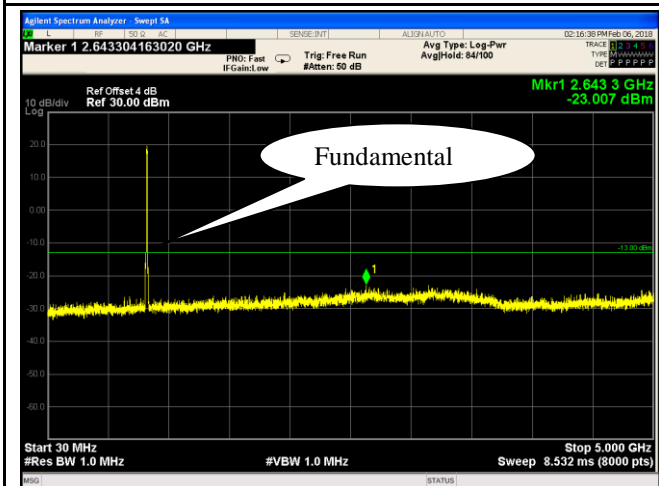

LTE Band V - High Channel-1

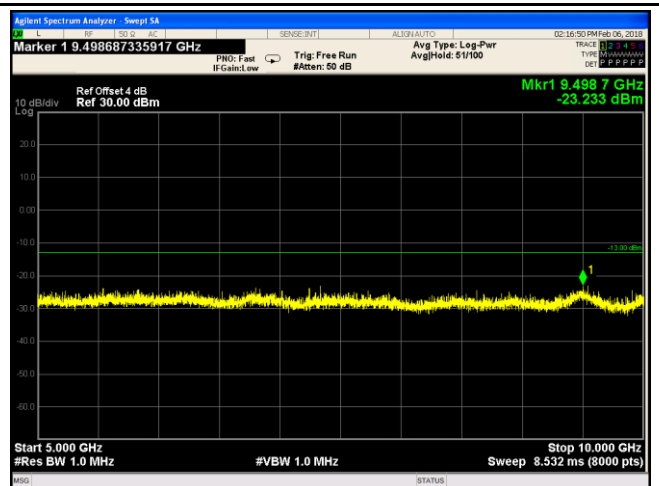

LTE Band V - High Channel-2

LTE Band VII (Part 27)

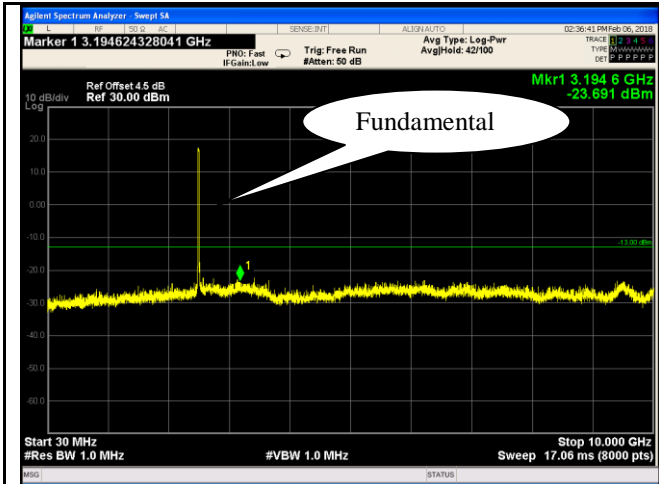

LTE Band VII - Low Channel-1

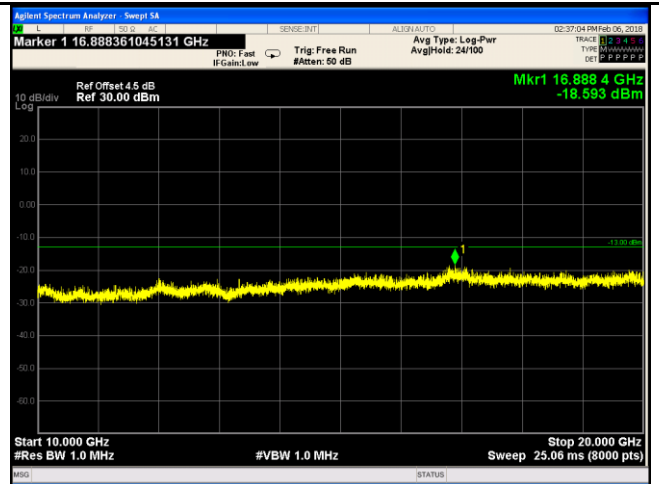

LTE Band VII - Low Channel-2

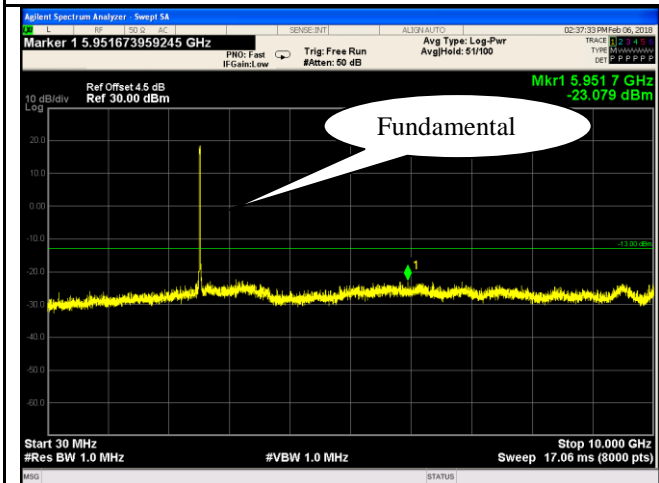

LTE Band VII - Middle Channel-1

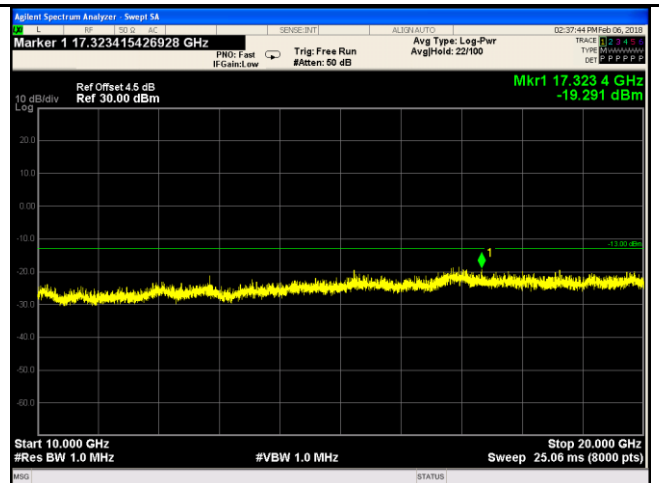

LTE Band VII - Middle Channel-2

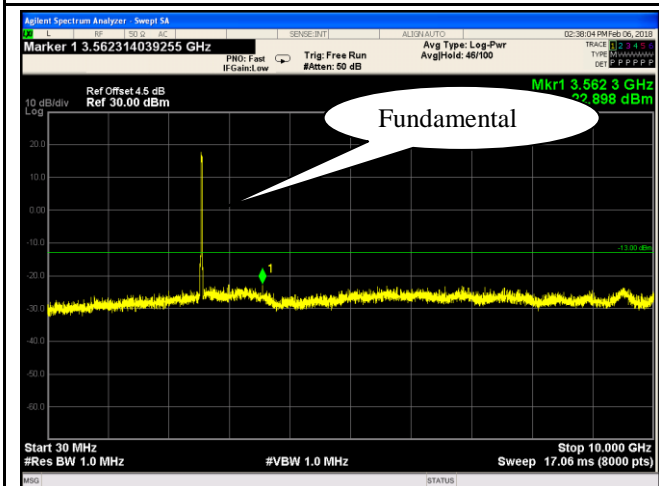

LTE Band VII - High Channel-1

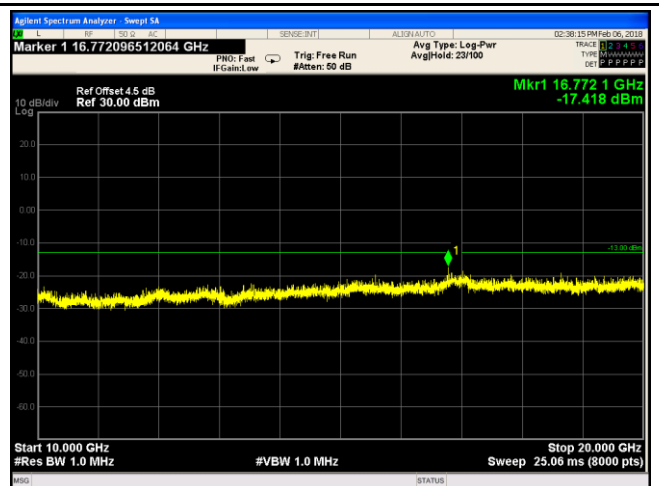

LTE Band VII - High Channel-2

6.6 Spurious Radiated Emissions

Temperature	24 °C
Relative Humidity	55%
Atmospheric Pressure	1013mbar
Test date :	February 05, 2018
Tested By :	Aarron Liang

Requirement(s):

Spec	Item	Requirement	Applicable
§2.1053, §22.917 & §24.238 § 27.53(h)	a)	The power of any emission outside of the authorized operating frequency ranges must be attenuated below the transmitter power (P) by a factor of at least $43 + 10 \log (P)$ dB. The spectrum is scanned from 30 MHz up to a frequency including its 10th harmonic.	<input checked="" type="checkbox"/>

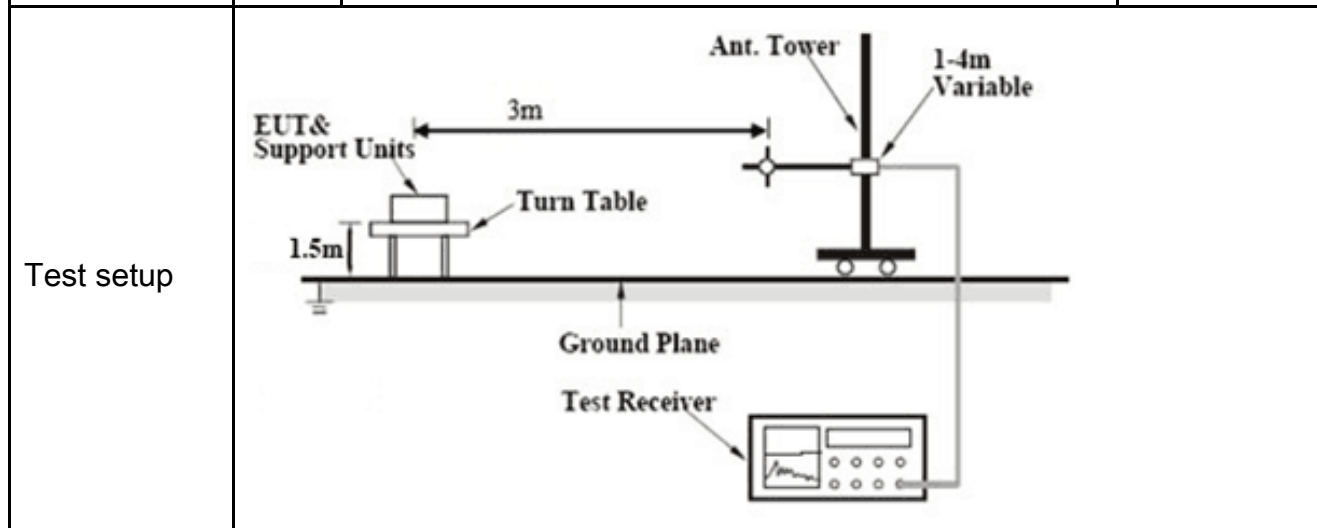

Test Procedure	<ol style="list-style-type: none"> The transmitter was placed on a wooden turntable, and it was transmitting into a non-radiating load which was also placed on the turntable. The measurement antenna was placed at a distance of 3 meters from the EUT. During the tests, the antenna height and polarization as well as EUT azimuth were varied in order to identify the maximum level of emissions from the EUT. The test was performed by placing the EUT on 3-orthogonal axis. Remove the EUT and replace it with substitution antenna. A signal generator was connected to the substitution antenna by a non-radiating cable. The absolute levels of the spurious emissions were measured by the substitution. <p>Sample Calculation:</p> $\text{EUT Field Strength} = \text{Raw Amplitude (dB}\mu\text{V/m)} - \text{Amplifier Gain (dB)} + \text{Antenna Factor (dB)} + \text{Cable Loss (dB)} + \text{Filter Attenuation (dB, if used)}$
----------------	---

Test Report	18070029-FCC-R5
Page	79 of 120

Remark	
Result	<input checked="" type="checkbox"/> Pass <input type="checkbox"/> Fail

Test Data Yes N/A
 Test Plot Yes (See below) N/A

LTE Band II (Part 24E) result

Low channel

Frequency (MHz)	Antenna Polarization (H/V)	Corrected Reading (dBm)	Limit (dBm)	Margin (dB)
3720	V	-28.92	-13	-15.92
3720	H	-33.85	-13	-20.85
312.67	V	-41.72	-13	-28.72
445.93	H	-40.3	-13	-27.3

Middle channel

Frequency (MHz)	Antenna Polarization (H/V)	Corrected Reading (dBm)	Limit (dBm)	Margin (dB)
3760	V	-33.52	-13	-20.52
3760	H	-28.9	-13	-15.9
614.33	V	-42.82	-13	-29.82
463.51	H	-41.01	-13	-28.01

High channel

Frequency (MHz)	Antenna Polarization (H/V)	Corrected Reading (dBm)	Limit (dBm)	Margin (dB)
3800	V	-31.86	-13	-18.86
3800	H	-29.48	-13	-16.48
425.19	V	-39.24	-13	-26.24
649.62	H	-39.67	-13	-26.67

Note:

1, The testing has been conformed to $10 \times 1907.5 \text{ MHz} = 19,075 \text{ MHz}$

2, All other emissions more than 30 dB below the limit

3, X-Axis, Y-Axis and Z-Axis were investigated. The results above show only the worst case.

LTE Band IV (Part27) result

Low channel

Frequency (MHz)	Antenna Polarization (H/V)	Corrected Reading (dBm)	Limit (dBm)	Margin (dB)
3440	V	-32.57	-13	-19.57
3440	H	-31.6	-13	-18.6
442.39	V	-45.71	-13	-32.71
581.73	H	-40.73	-13	-27.73

Middle channel

Frequency (MHz)	Antenna Polarization (H/V)	Corrected Reading (dBm)	Limit (dBm)	Margin (dB)
3465	V	-31.3	-13	-18.3
3465	H	-29.52	-13	-16.52
609.75	V	-40.19	-13	-27.19
429.17	H	-34.78	-13	-21.78

High channel

Frequency (MHz)	Antenna Polarization (H/V)	Corrected Reading (dBm)	Limit (dBm)	Margin (dB)
3490	V	-34.83	-13	-21.83
3490	H	-32.95	-13	-19.95
208.74	V	-38.8	-13	-25.8
769.29	H	-40.66	-13	-27.66

Note:

- 1, The testing has been conformed to $10 \times 1752.5 \text{MHz} = 17,525 \text{MHz}$
- 2, All other emissions more than 30 dB below the limit
- 3, X-Axis, Y-Axis and Z-Axis were investigated. The results above show only the worst case.

LTE Band V (Part22H) result

Low channel

Frequency (MHz)	Antenna Polarization (H/V)	Corrected Reading (dBm)	Limit (dBm)	Margin (dB)
1658	V	-32.87	-13	-19.87
1658	H	-30.97	-13	-17.97
684.51	V	-45.92	-13	-32.92
662.37	H	-37.48	-13	-24.48

Middle channel

Frequency (MHz)	Antenna Polarization (H/V)	Corrected Reading (dBm)	Limit (dBm)	Margin (dB)
1673	V	-33.84	-13	-20.84
1673	H	-29.06	-13	-16.06
438.02	V	-46.07	-13	-33.07
491.58	H	-40.38	-13	-27.38

High channel

Frequency (MHz)	Antenna Polarization (H/V)	Corrected Reading (dBm)	Limit (dBm)	Margin (dB)
1688	V	-36.13	-13	-23.13
1688	H	-35.47	-13	-22.47
364	V	-42.48	-13	-29.48
543.05	H	-36.43	-13	-23.43

Note:

- 1, The testing has been conformed to $10 \times 846.5 \text{MHz} = 8,465 \text{MHz}$
- 2, All other emissions more than 30 dB below the limit
- 3, X-Axis, Y-Axis and Z-Axis were investigated. The results above show only the worst case.

LTE Band VII (Part27) result

Low channel

Frequency (MHz)	Antenna Polarization (H/V)	Corrected Reading (dBm)	Limit (dBm)	Margin (dB)
5020	V	-30.96	-13	-17.96
5020	H	-35.23	-13	-22.23
715.04	V	-43.22	-13	-30.22
795.88	H	-39.33	-13	-26.33

Middle channel

Frequency (MHz)	Antenna Polarization (H/V)	Corrected Reading (dBm)	Limit (dBm)	Margin (dB)
5070	V	-34.44	-13	-21.44
5070	H	-31.26	-13	-18.26
477.84	V	-43.01	-13	-30.01
342.14	H	-34.33	-13	-21.33

High channel

Frequency (MHz)	Antenna Polarization (H/V)	Corrected Reading (dBm)	Limit (dBm)	Margin (dB)
5120	V	-31.92	-13	-18.92
5120	H	-29.33	-13	-16.33
428.34	V	-39.86	-13	-26.86
387.76	H	-35.06	-13	-22.06

Note:

1, The testing has been conformed to $10 \times 2567.5 \text{ MHz} = 25,675 \text{ MHz}$

2, All other emissions more than 30 dB below the limit

3, X-Axis, Y-Axis and Z -Axis were investigated. The results above show only the worst case.

6.7 Band Edge

Temperature	25 °C
Relative Humidity	54%
Atmospheric Pressure	1010mbar
Test date :	February 06, 2018
Tested By :	Aarron Liang

Requirement(s):

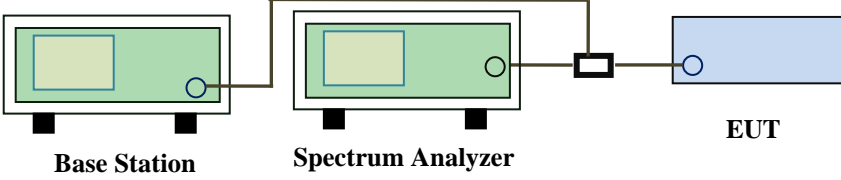
Spec	Item	Requirement	Applicable
§22.917(a) §24.238(a) § 27.53(h)	a)	The power of any emission outside of the authorized operating frequency ranges must be lower than the transmitter power (P) by a factor of at least $43 + 10 \log (P)$ dB.	<input checked="" type="checkbox"/>
Test setup	 <p>The diagram shows a Base Station (green box) connected to a Spectrum Analyzer (green box) and an EUT (blue box) via a power divider (black box). The Base Station and Spectrum Analyzer are connected to each other, and the Spectrum Analyzer is connected to the power divider, which then splits the signal to the EUT.</p>		
Procedure	<ul style="list-style-type: none"> - The EUT was connected to Spectrum Analyzer and Base Station via power divider. - The Band Edges of low and high channels for the highest RF powers were measured. Setting RBW as roughly BW/100. 		
Remark			
Result	<input checked="" type="checkbox"/> Pass <input type="checkbox"/> Fail		

Test Data Yes N/A

Test Plot Yes (See below) N/A

LTE Band II (Part 24E) result

BW(MHz)	Channel	Frequency (MHz)	Mode	Emission (dBm)	Limit (dBm)
1.4	18607	1850	16QAM	-26.981	-13
			QPSK	-27.059	-13
1.4	18900	1910	16QAM	-26.58	-13
			QPSK	-25.151	-13
3	18615	1850	16QAM	-23.966	-13
			QPSK	-22.174	-13
3	19185	1910	16QAM	-24.694	-13
			QPSK	-24.861	-13
5	18625	1850	16QAM	-16.801	-13
			QPSK	-17.217	-13
5	19175	1910	16QAM	-16.15	-13
			QPSK	-16.697	-13
10	18650	1850	16QAM	-16.798	-13
			QPSK	-17.015	-13
10	19150	1910	16QAM	-17.685	-13
			QPSK	-16.438	-13
15	18675	1850	16QAM	-19.27	-13
			QPSK	-18.96	-13
15	19125	1910	16QAM	-19.367	-13
			QPSK	-20.46	-13
20	18700	1850	16QAM	-27.13	-13
			QPSK	-25.406	-13
20	19100	1910	16QAM	-23.681	-13
			QPSK	-24.212	-13

LTE Band IV (Part 27) result

BW(MHz)	Channel	Frequency (MHz)	Mode	Emission (dBm)	Limit (dBm)
1.4	19957	1709.9	16QAM	-25.078	-13
			QPSK	-26.224	-13
1.4	20393	1755	16QAM	-27.597	-13
			QPSK	-23.495	-13
3	19965	1709.9	16QAM	-26.614	-13
			QPSK	-26.155	-13
3	20385	1755	16QAM	-.24.026	-13
			QPSK	-23.966	-13
5	19975	1709.9	16QAM	-16.536	-13
			QPSK	-17.978	-13
5	20375	1755	16QAM	-16.667	-13
			QPSK	-17.686	-13
10	20000	1709.9	16QAM	-15.976	-13
			QPSK	-16.14	-13
10	20350	1755	16QAM	-19.275	-13
			QPSK	-17.623	-13
15	20025	1709.9	16QAM	-19.606	-13
			QPSK	-19.66	-13
15	20325	1755	16QAM	-21.923	-13
			QPSK	-20.226	-13
20	20050	1709.9	16QAM	-24.825	-13
			QPSK	-23.325	-13
20	20300	1755	16QAM	-19.423	-13
			QPSK	-20.234	-13

LTE Band V (Part 22H) result

BW(MHz)	Channel	Frequency (MHz)	Mode	Emission (dBm)	Limit (dBm)
1.4	20407	823.9	16QAM	-22.676	-13
			QPSK	-23.007	-13
1.4	20643	849	16QAM	-27.719	-13
			QPSK	-28.503	-13
3	20415	824	16QAM	-21.749	-13
			QPSK	-22.177	-13
3	20635	849	16QAM	-20.542	-13
			QPSK	-20.542	-13
5	20425	824	16QAM	-16.33	-13
			QPSK	-16.918	-13
5	20625	849	16QAM	-17.251	-13
			QPSK	-17.278	-13
10	20450	824	16QAM	-14.964	-13
			QPSK	-15.292	-13
10	20800	849	16QAM	-17.792	-13
			QPSK	-16.469	-13

Test Plots

LTE Band II (Part 24E)

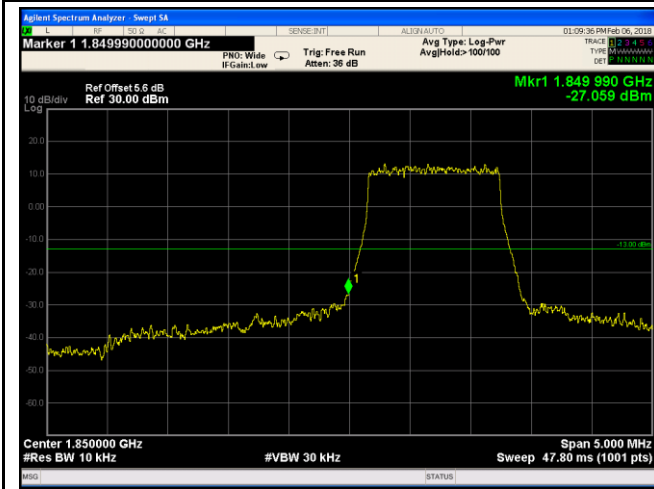

LTE Band II - Low Channel QPSK-1.4

Note: Offset=Cable loss (4.5) + 10log
(13.01/10)=4.5+1.1=5.6dB

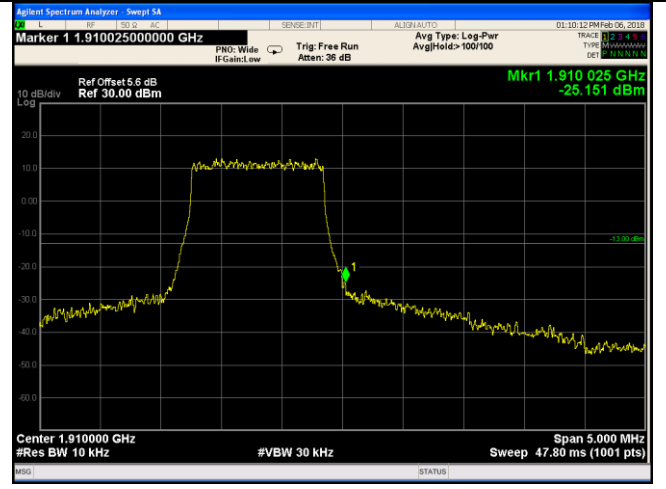

LTE Band II - High Channel QPSK-1.4

Note: Offset=Cable loss (4.5) + 10log
(13.01/10)=4.5+1.1=5.6dB

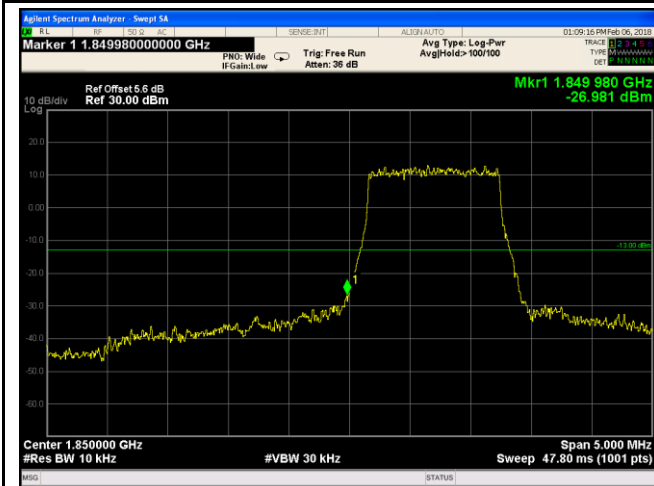

LTE Band II - Low Channel 16QAM-1.4

Note: Offset=Cable loss (4.5) + 10log
(13.13/10)=4.5+1.1=5.6 dB

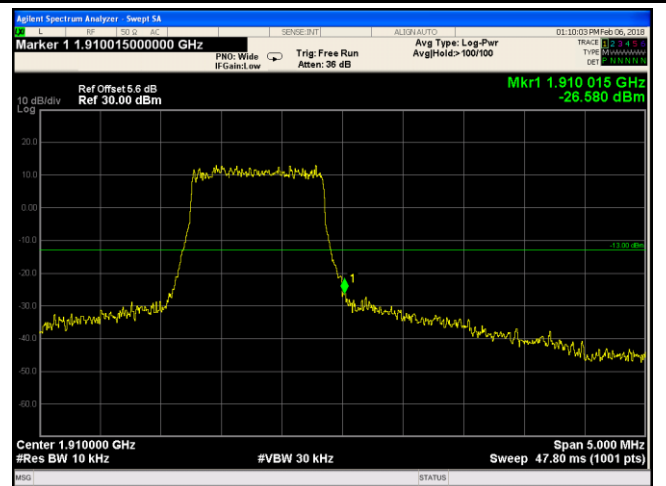

LTE Band II - High Channel 16QAM-1.4

Note: Offset=Cable loss (4.5) + 10log
(13.07/10)=4.5+1.1=5.6 dB

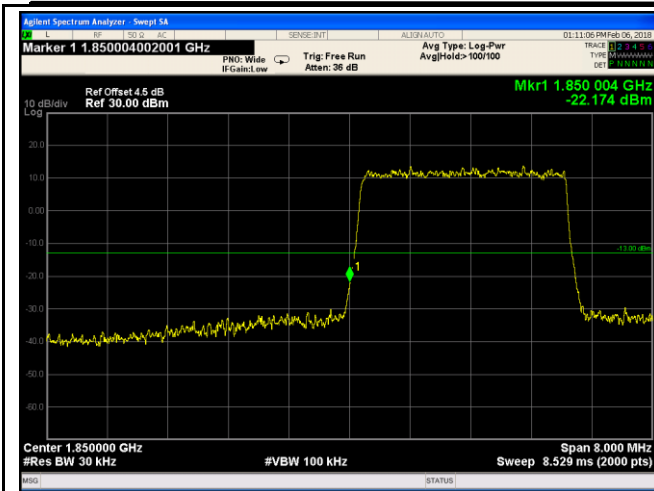

LTE Band II - Low Channel QPSK-3

Note: Offset=Cable loss (4.5) + 10log
(30.12/30)=4.5+0.0=4.5 dB

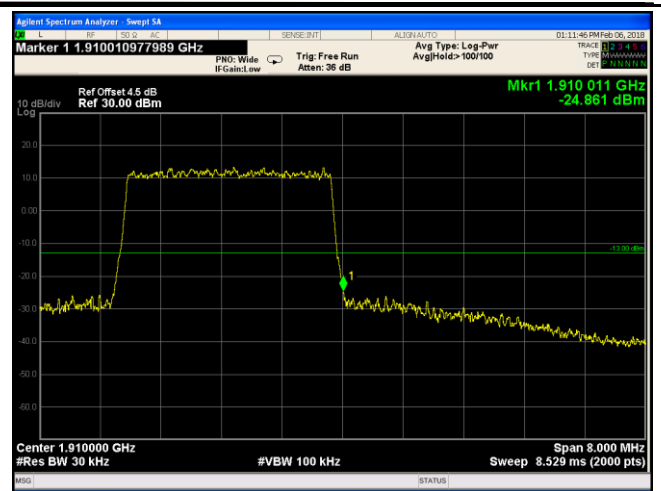

LTE Band II - High Channel QPSK-3

Note: Offset=Cable loss (4.5) + 10log
(30.01/30)=4.5+0.0=4.5 dB

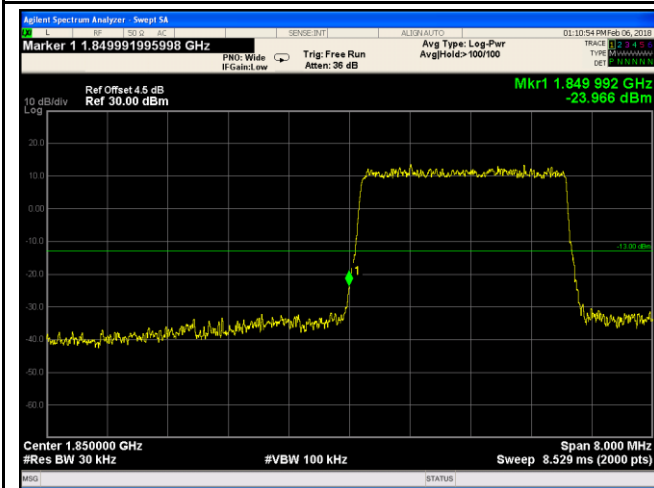

LTE Band II - Low Channel 16QAM-3

Note: Offset=Cable loss (4.5) + 10log
(29.95/30)=4.5+0.0=4.0 dB

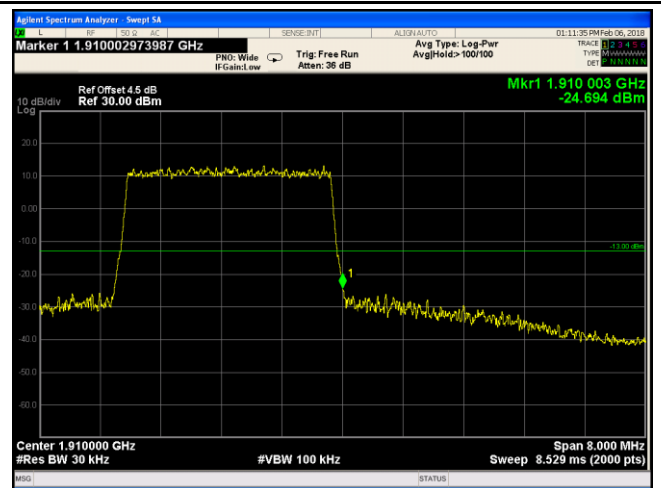

LTE Band II - High Channel 16QAM-3

Note: Offset=Cable loss (4.5) + 10log
(30.02/30)=4.5+0.0=4.5 dB

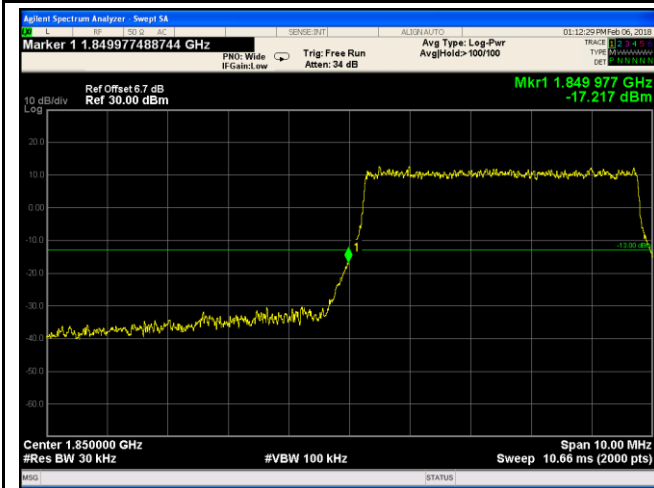

LTE Band II - Low Channel QPSK-5

Note: Offset=Cable loss (4.5) + 10log
(51.71/30)=4.5+2.7=6.7dB

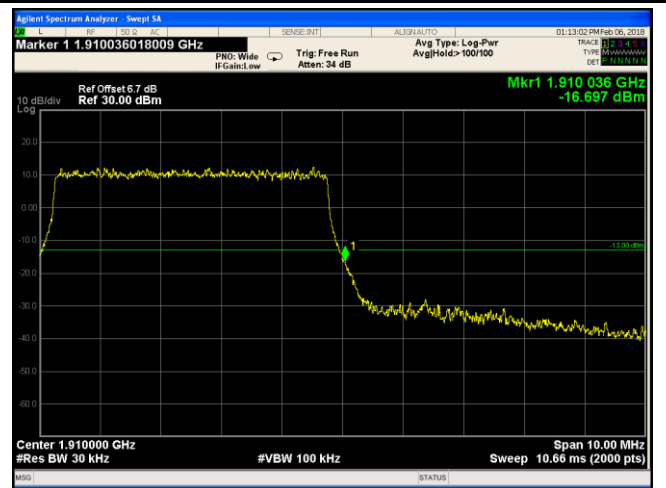

LTE Band II - High Channel QPSK-5

Note: Offset=Cable loss (4.5) + 10log
(51.47/30)=4.5+2.2=6.7 dB

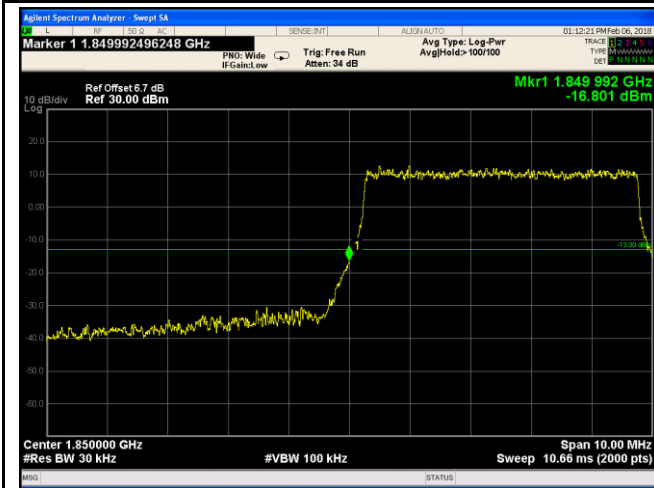

LTE Band II - Low Channel 16QAM-5

Note: Offset=Cable loss (4.5) + 10log
(51.96/30)=4.5+2.2=6.7 dB

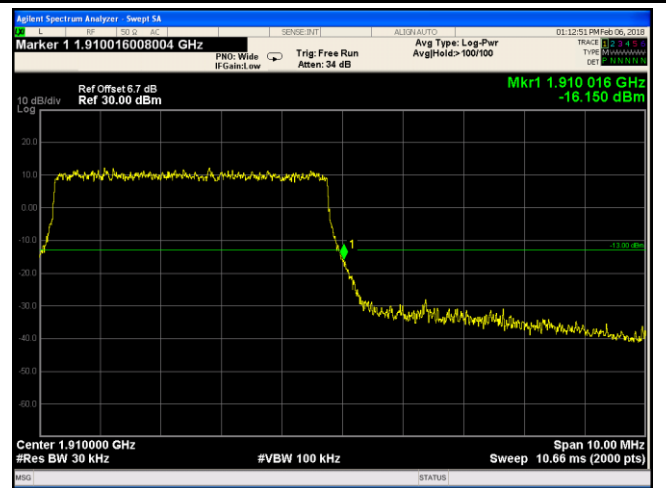

LTE Band II - High Channel 16QAM-5

Note: Offset=Cable loss (4.5) + 10log
(51.90/30)=4.5+2.2=6.7 dB

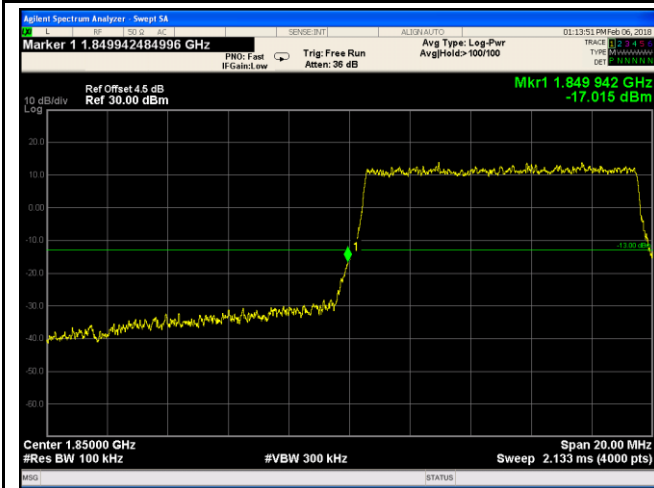

LTE Band II - Low Channel QPSK-10

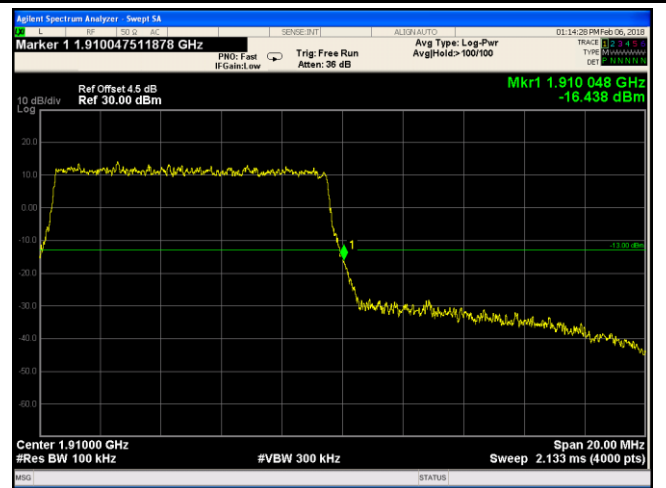

LTE Band II - High Channel QPSK-10

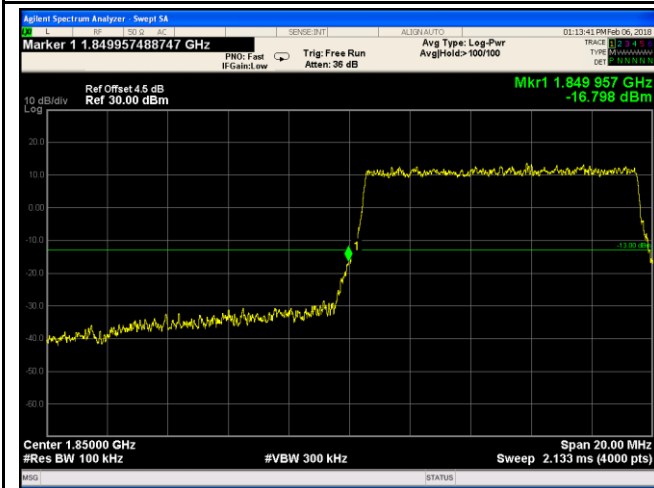

LTE Band II - Low Channel 16QAM-10

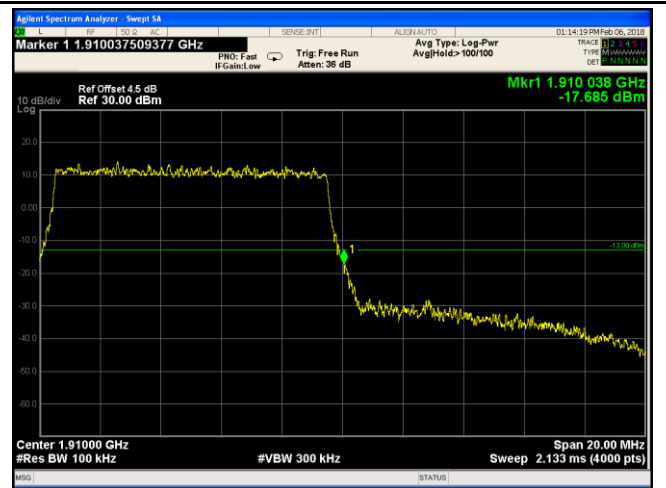

LTE Band II - High Channel 16QAM-10

Note: Offset=Cable loss (4.5) + 10log
(103.3/100)=4.5+0.0=4.5 dB

Note: Offset=Cable loss (4.5) + 10log
(101.9/100)=4.5+0.0=4.5 dB

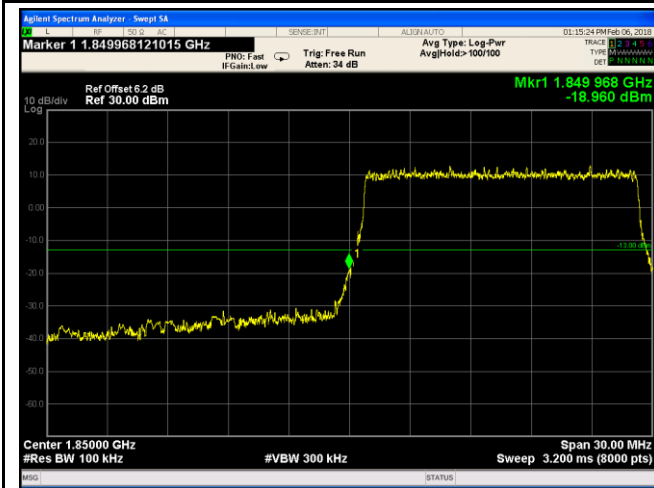

LTE Band II - Low Channel QPSK-15

Note: Offset=Cable loss (4.5) + 10log
(150.2/100)=4.5+2.3=6.2 dB

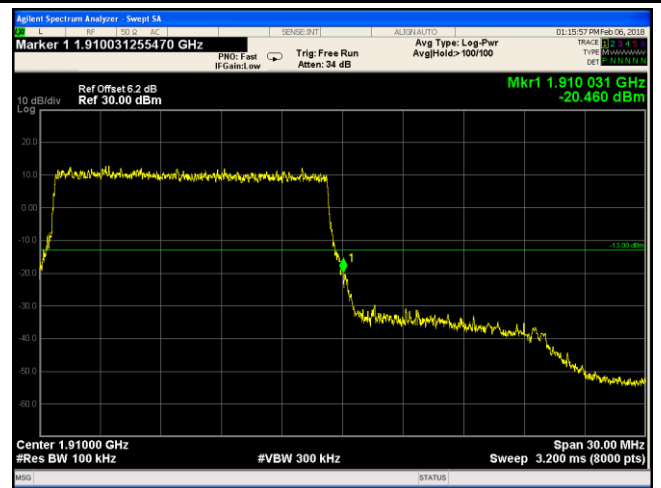

LTE Band II - High Channel QPSK-15

Note: Offset=Cable loss (4.5) + 10log
(151.3/100)=4.5+2.3=6.2 dB

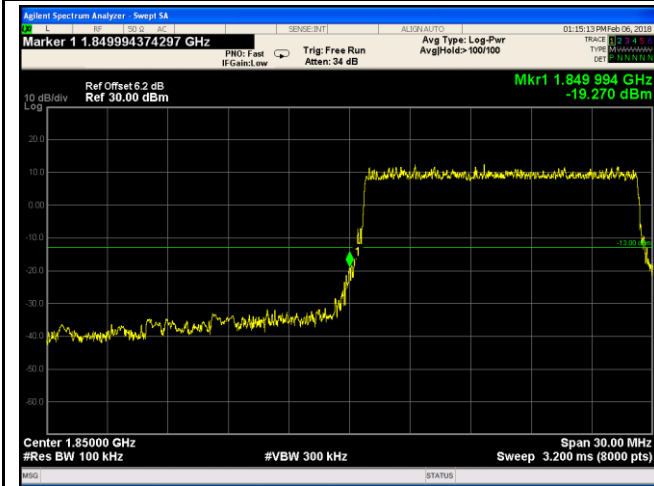

LTE Band II - Low Channel 16QAM-15

Note: Offset=Cable loss (4.5) + 10log
(150.1/100)=4.5+2.3=6.2 dB

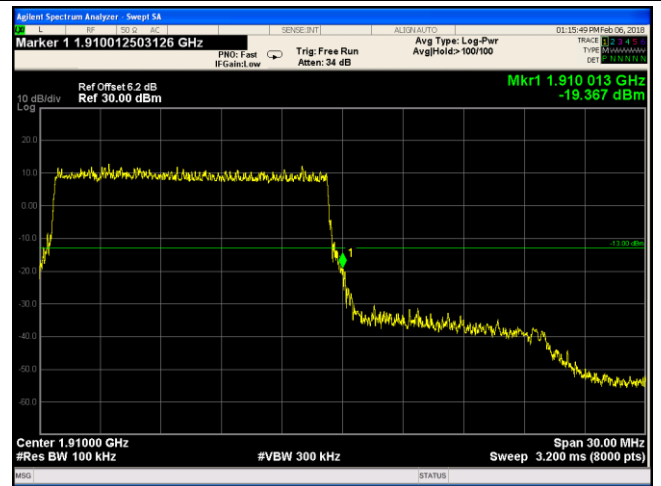

LTE Band II - High Channel 16QAM-15

Note: Offset=Cable loss (4.5) + 10log
(150.7/100)=4.5+2.3=6.2 dB

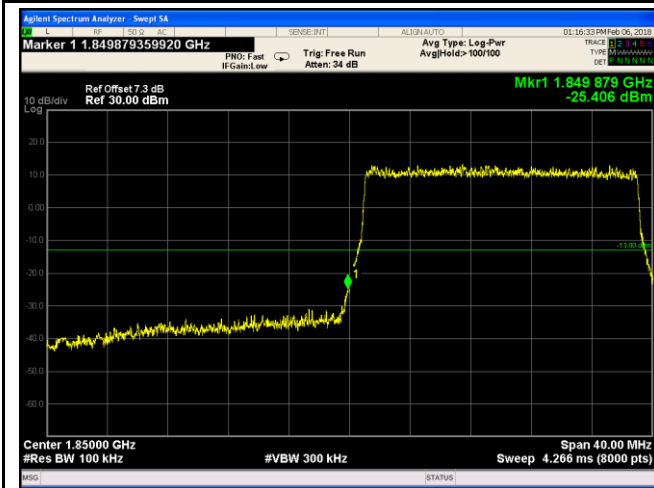

LTE Band II - Low Channel QPSK-20

Note: Offset=Cable loss (4.5) + 10log
(194.2/100)=4.5+2.8=7.3 dB

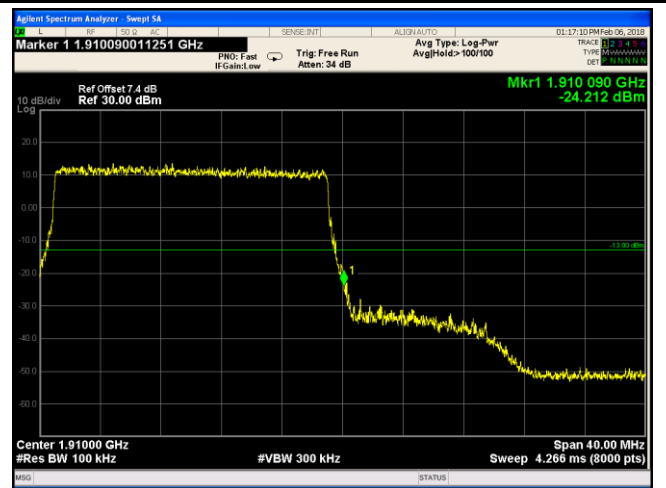

LTE Band II - High Channel QPSK-20

Note: Offset=Cable loss (4.5) + 10log
(198.2/100)=4.5+2.9=7.4 dB

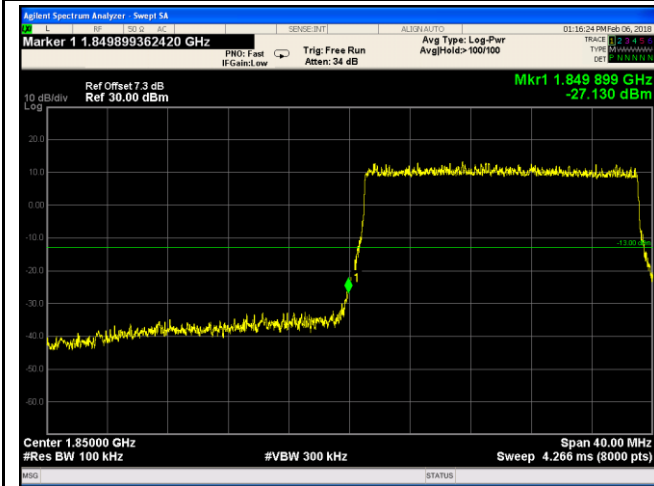

LTE Band II - Low Channel 16QAM-20

Note: Offset=Cable loss (4.5) + 10log
(191.9/100)=4.5+2.8=7.3 dB

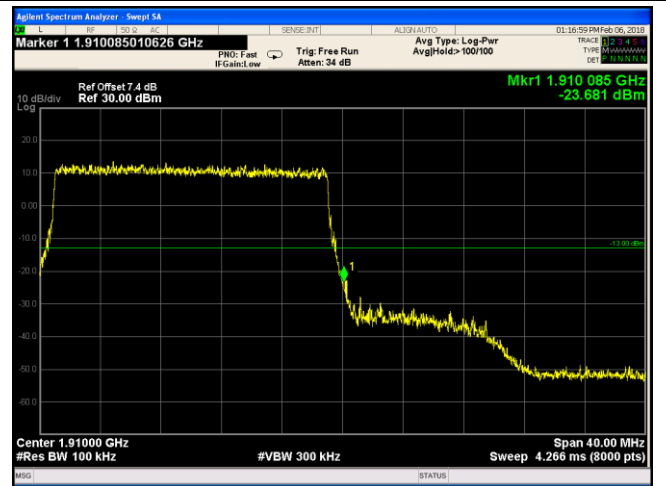

LTE Band II - High Channel 16QAM-20

Note: Offset=Cable loss (4.5) + 10log
(196/100)=4.5+2.9=7.4 dB

LTE Band IV (Part 27)

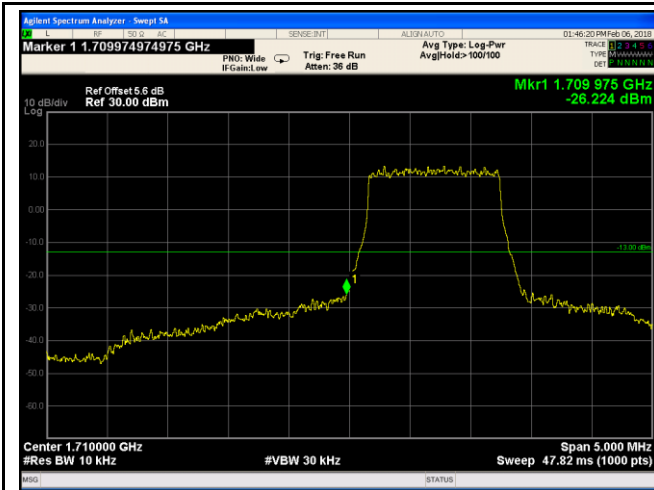

LTE Band IV - Low Channel QPSK-1.4

Note: Offset=Cable loss (4.5) + 10log
(13.10/10)=4.5+1.1=5.6 dB

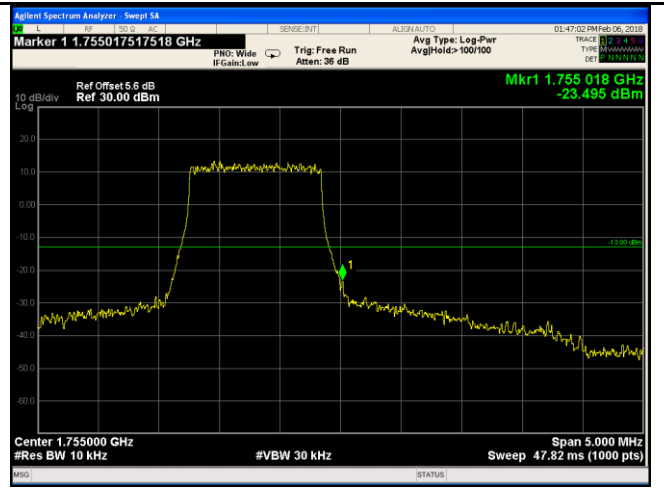

LTE Band IV - High Channel QPSK-1.4

Note: Offset=Cable loss (4.5) + 10log
(13.11/10)=4.5+1.1=5.6 dB

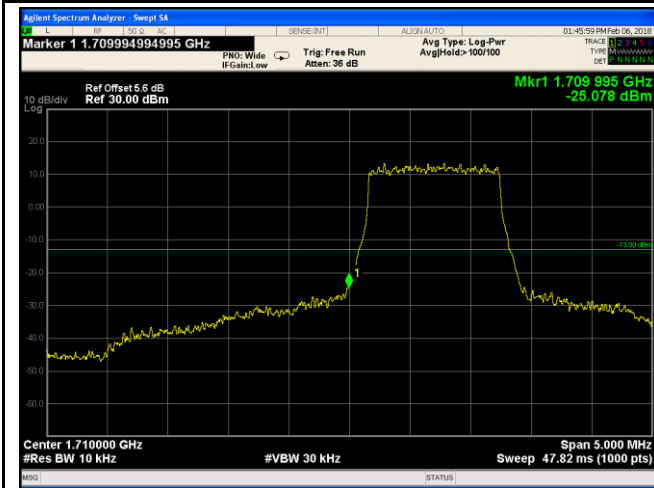

LTE Band IV - Low Channel 16QAM-1.4

Note: Offset=Cable loss (4.5) + 10log
(13.37/10)=4.5+1.1=5.6 dB

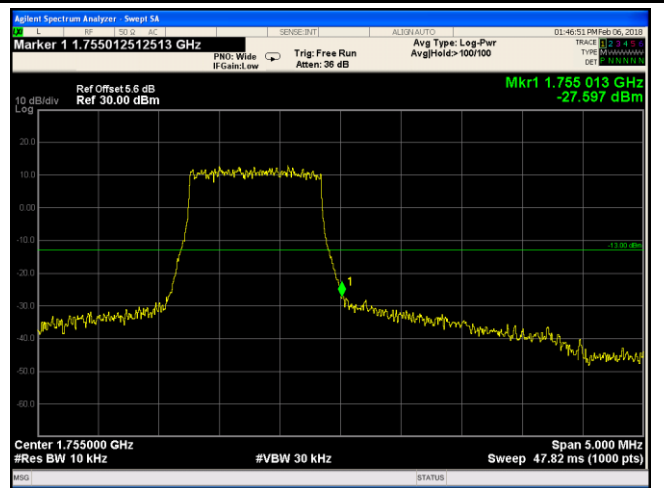

LTE Band IV - High Channel 16QAM-1.4

Note: Offset=Cable loss (4.5) + 10log
(130.7/10)=4.5+1.1=5.6 dB

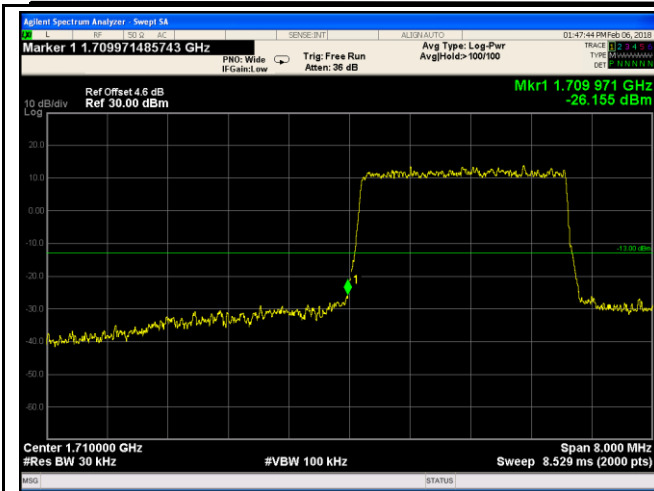

LTE Band IV - Low Channel QPSK-3

Note: Offset=Cable loss (4.5) + 10log
(30.22/30)=4.5+0.1=4.6 dB

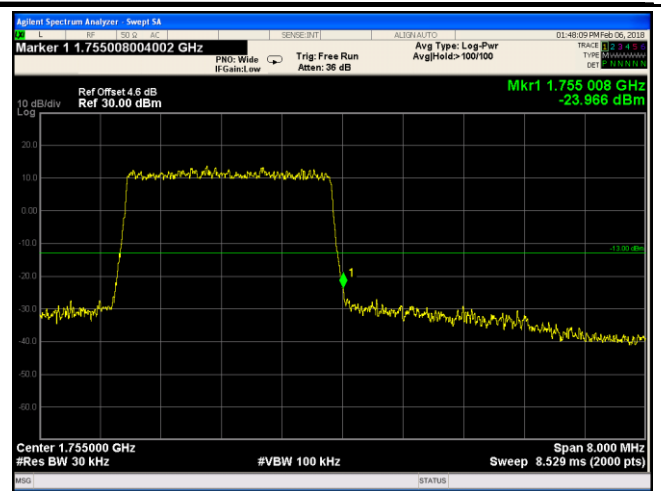

LTE Band IV - High Channel QPSK-3

Note: Offset=Cable loss (4.5) + 10log
(30.14/30)=4.5+0.1=4.6 dB

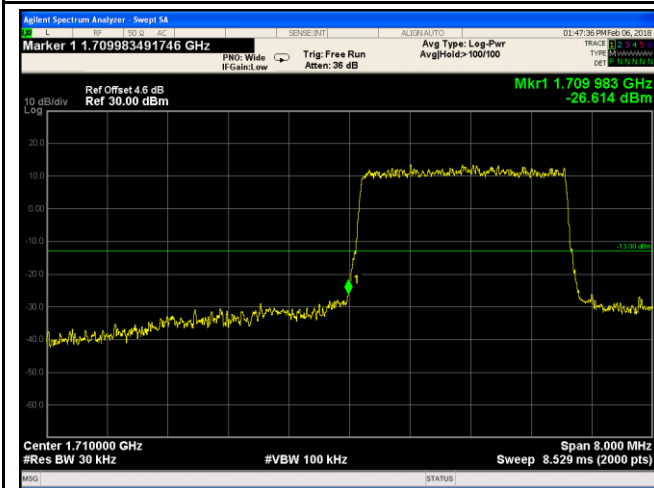

LTE Band IV - Low Channel 16QAM-3

Note: Offset=Cable loss (4.5) + 10log
(30.22/30)=4.5+0.1=4.6 dB

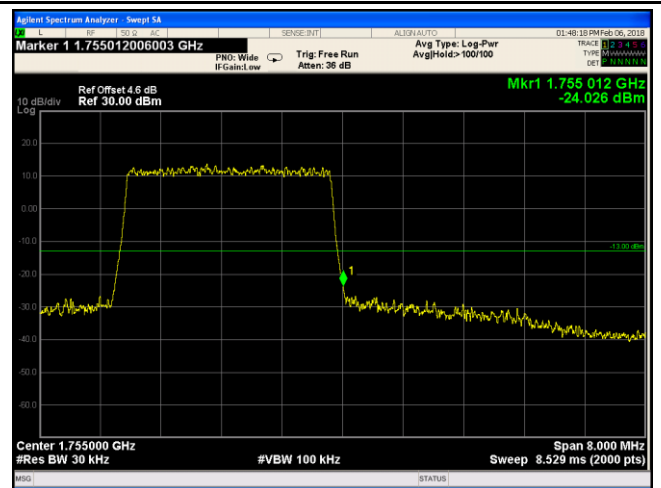

LTE Band IV - High Channel 16QAM-3

Note: Offset=Cable loss (4.5) + 10log
(30.11/30)=4.5+0.1=4.6 dB

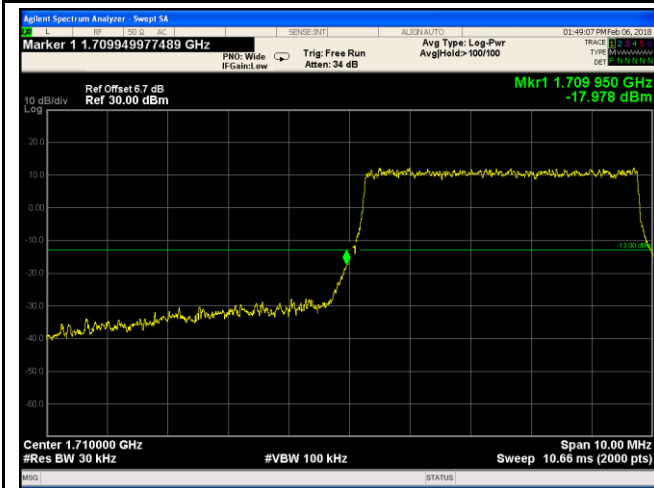

LTE Band IV - Low Channel QPSK-5

Note: Offset=Cable loss (4.5) + 10log
(52.40/30)=4.5+2.2=6.7 dB

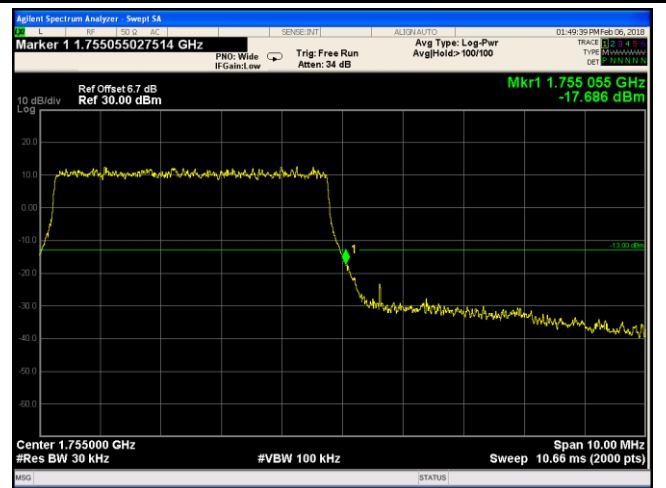

LTE Band IV - High Channel QPSK-5

Note: Offset=Cable loss (4.5) + 10log
(51.34/30)=4.5+2.2=6.7dB

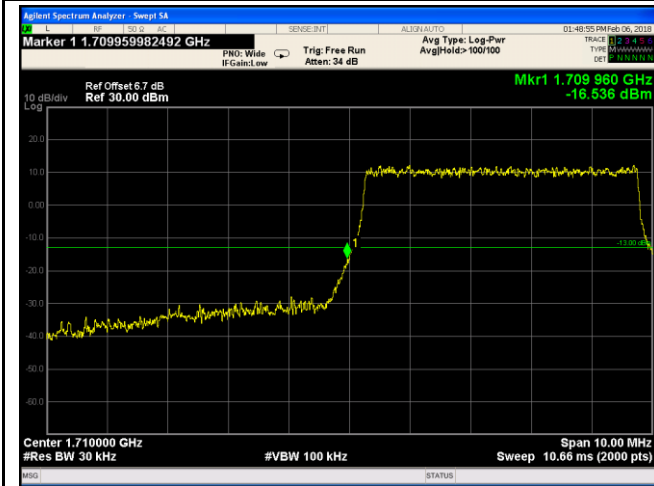

LTE Band IV - Low Channel 16QAM-5

Note: Offset=Cable loss (4.5) + 10log
(52.40/30)=4.5+2.2=6.7 dB

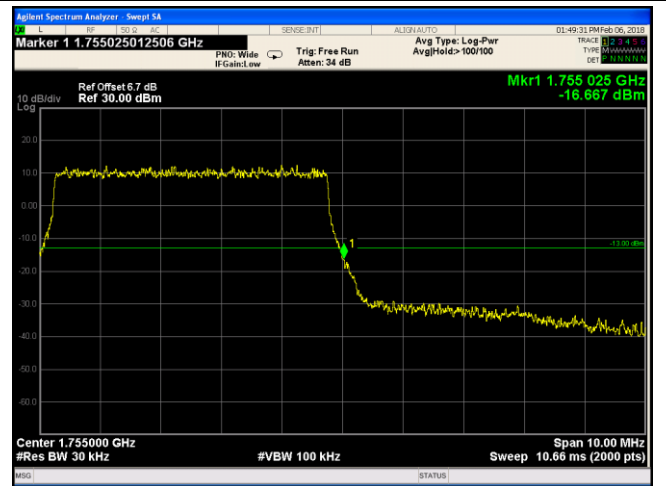

LTE Band IV - High Channel 16QAM-5

Note: Offset=Cable loss (4.5) + 10log
(51.68/30)=4.5+2.2=6.7 dB

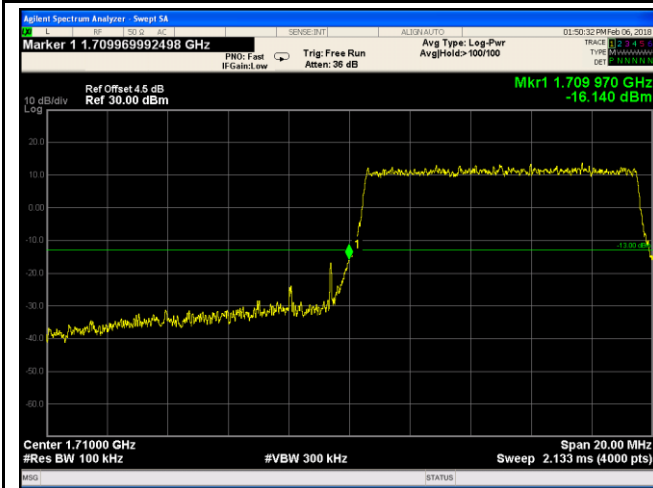

LTE Band IV - Low Channel QPSK-10

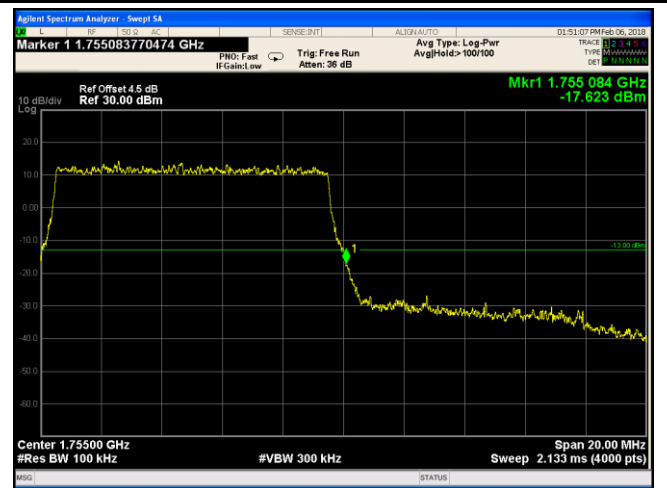

LTE Band IV - High Channel QPSK-10

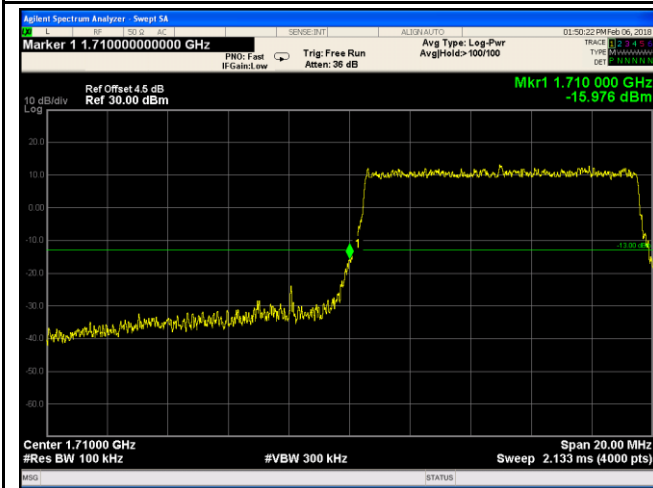

LTE Band IV - Low Channel 16QAM-10

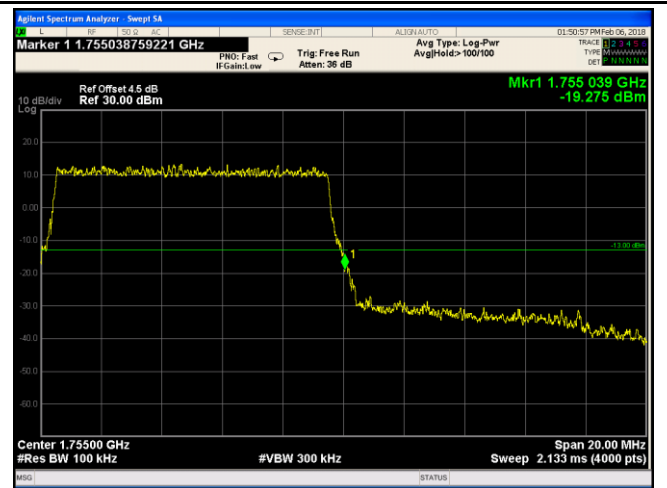

LTE Band IV - High Channel 16QAM-10

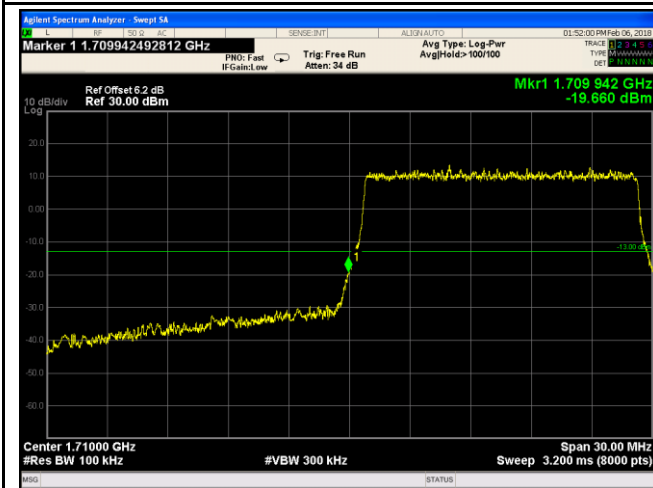

LTE Band IV - Low Channel QPSK-15



LTE Band IV - High Channel QPSK-15

Note: Offset=Cable loss (4.5) + 10log
(150/100)=4.5+1.7=6.2 dB

Note: Offset=Cable loss (4.5) + 10log
(150.8/100)=4.5+1.7=6.2 dB

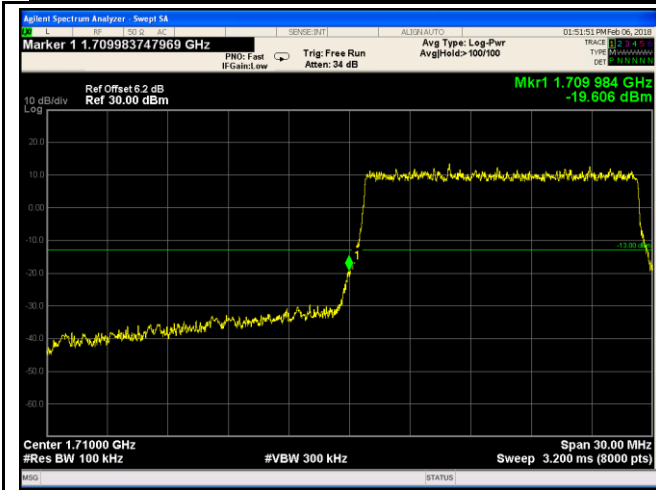

LTE Band IV - Low Channel 16QAM-15

Note: Offset=Cable loss (4.5) + 10log
 $(149.9/100)=4.5+1.7=6.2$ dB

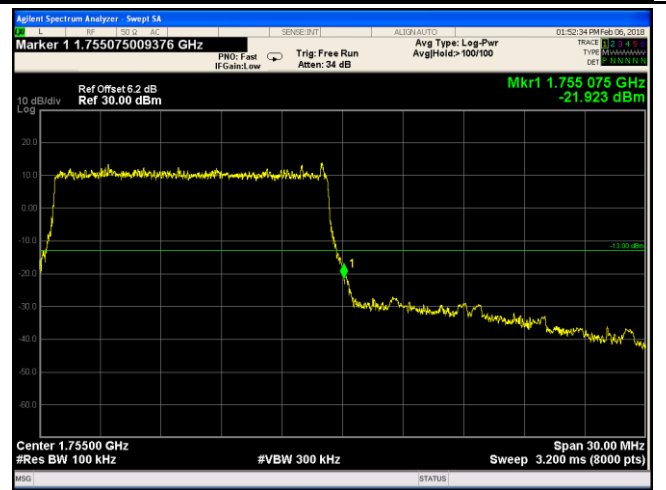

LTE Band IV - High Channel 16QAM-15

Note: Offset=Cable loss (4.5) + 10log
 $(149.9/100)=4.5+1.7=6.2$ dB

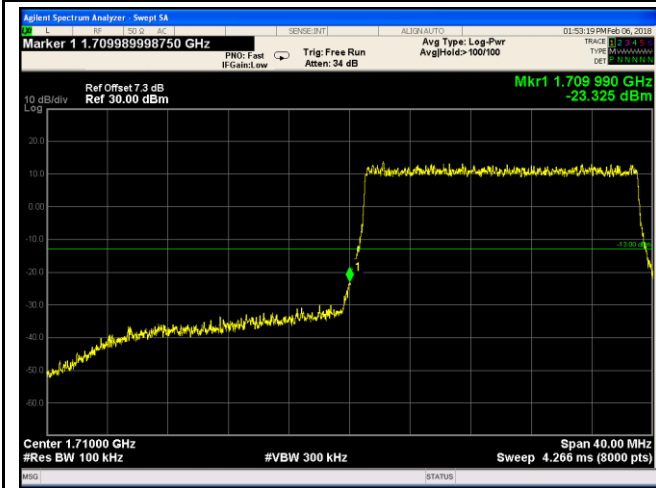

LTE Band IV - Low Channel QPSK-20

Note: Offset=Cable loss (4.5) + 10log
 $(194.4/100)=4.5+2.8=7.3$ dB

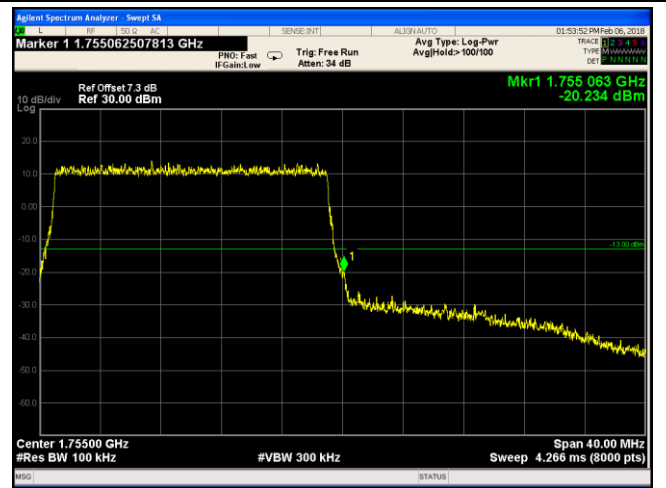

LTE Band IV - High Channel QPSK-20

Note: Offset=Cable loss (4.5) + 10log
 $(197/100)=4.5+2.8=7.3$ dB

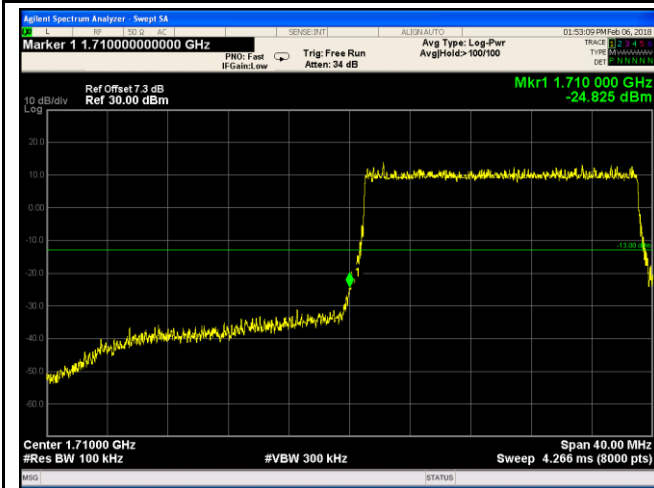

LTE Band IV - Low Channel 16QAM-20

Note: Offset=Cable loss (4.5) + 10log
(194.7/100)=4.5+2.8=7.3dB

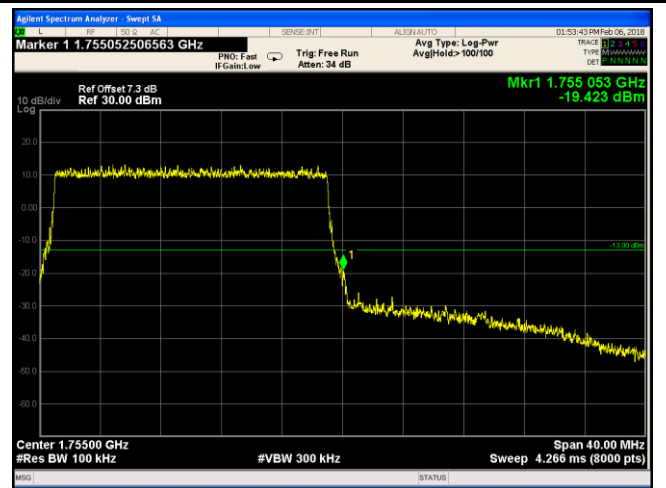

LTE Band IV - High Channel 16QAM-20

Note: Offset=Cable loss (4.5) + 10log
(194.8/100)=4.5+2.8=7.3 dB

LTE Band V (Part 22H)

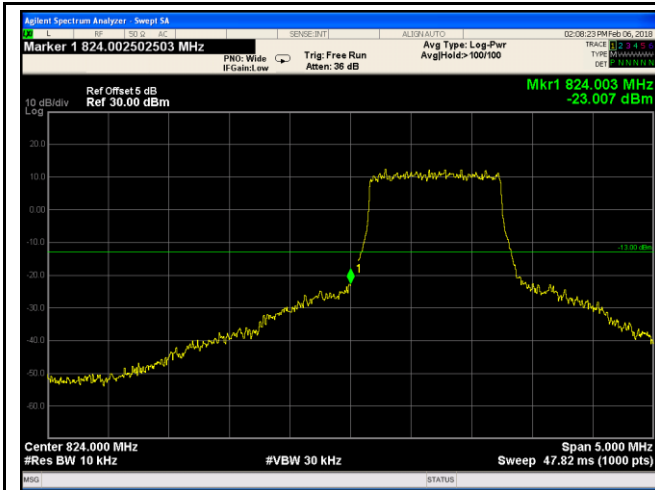

LTE Band V - Low Channel QPSK-1.4

Note: Offset=Cable loss (4.5) + 10log
(13.11/10)=4.5+0.5=5.0 dB

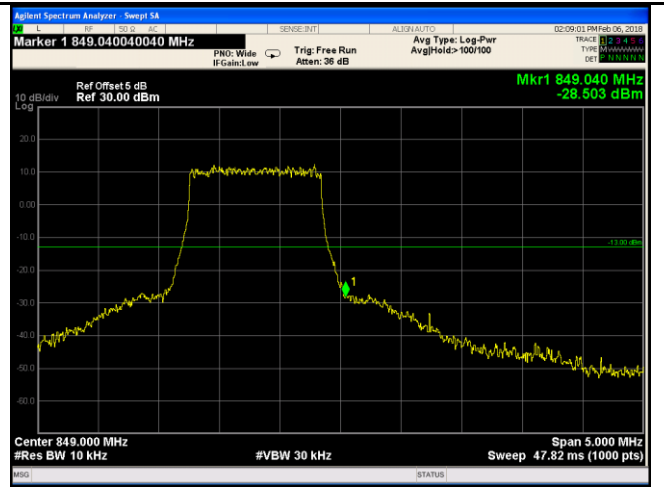

LTE Band V - High Channel QPSK-1.4

Note: Offset=Cable loss (4.5) + 10log
(13.25/10)=4.5+0.5=5.0 dB

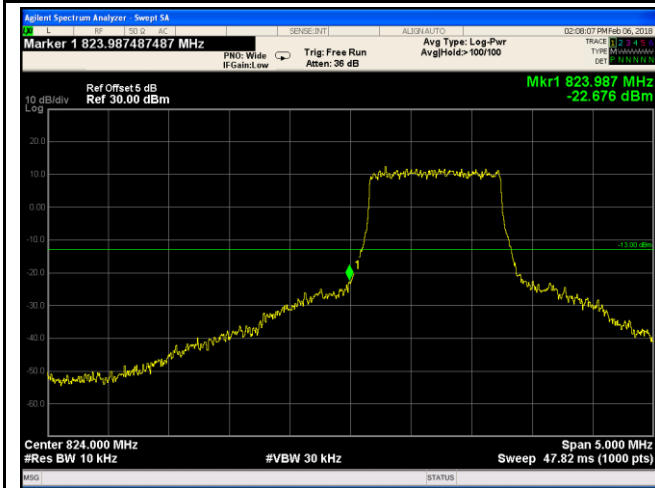

LTE Band V - Low Channel 16QAM-1.4

Note: Offset=Cable loss (4.5) + 10log
(12.93/10)=4.5+0.5=5.0dB

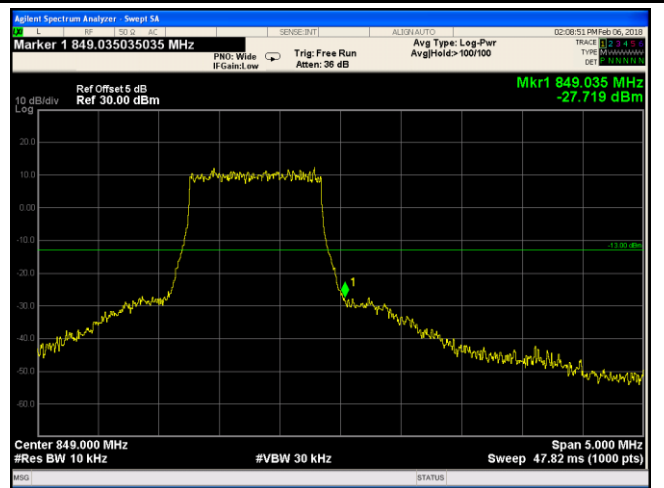

LTE Band V - High Channel 16QAM-1.4

Note: Offset=Cable loss (4.5) + 10log
(13.19/10)=4.5+0.5=5.0dB