

FCC Test Report

Report No.: RF161017C10-1

FCC ID: 2ADYF-OAP30

Test Model: OAP30

Received Date: Oct. 17, 2016

Test Date: Oct. 29 ~ Nov. 11, 2016

Issued Date: Nov. 17, 2016

Applicant: KodaCloud, Inc.

Address: 1901 South Bascom Ave, Suite 1300, Campbell, CA USA 95008

Issued By: Bureau Veritas Consumer Products Services (H.K.) Ltd., Taoyuan Branch

Lab Address: No. 47-2, 14th Ling, Chia Pau Vil., Lin Kou Dist., New Taipei City, Taiwan (R.O.C.)

Test Location: No.19, Hwa Ya 2nd Rd., Wen Hwa Vil., Kwei Shan Dist., Taoyuan City 33383, TAIWAN (R.O.C.)



This report is for your exclusive use. Any copying or replication of this report to or for any other person or entity, or use of our name or trademark, is permitted only with our prior written permission. This report sets forth our findings solely with respect to the test samples identified herein. The results set forth in this report are not indicative or representative of the quality or characteristics of the lot from which a test sample was taken or any similar or identical product unless specifically and expressly noted. Our report includes all of the tests requested by you and the results thereof based upon the information that you provided to us. You have 60 days from date of issuance of this report to notify us of any material error or omission caused by our negligence, provided, however, that such notice shall be in writing and shall specifically address the issue you wish to raise. A failure to raise such issue within the prescribed time shall constitute your unqualified acceptance of the completeness of this report, the tests conducted and the correctness of the report contents. Unless specifically mentioned, the uncertainty of measurement has been explicitly taken into account to declare the compliance or non-compliance to the specification. The report must not be used by the client to claim product certification, approval, or endorsement by TAF or any government agencies.

Table of Contents

Release Control Record	4
1 Certificate of Conformity	5
2 Summary of Test Results	6
2.1 Measurement Uncertainty.....	6
2.2 Modification Record.....	6
3 General Information	7
3.1 General Description of EUT.....	7
3.2 Description of Test Modes.....	9
3.2.1 Test Mode Applicability and Tested Channel Detail.....	10
3.3 Duty Cycle of Test Signal.....	12
3.4 Description of Support Units.....	13
3.4.1 Configuration of System under Test.....	13
3.5 General Description of Applied Standards.....	14
4 Test Types and Results	15
4.1 Radiated Emission and Bandedge Measurement.....	15
4.1.1 Limits of Radiated Emission and Bandedge Measurement.....	15
4.1.2 Test Instruments.....	16
4.1.3 Test Procedures.....	17
4.1.4 Deviation from Test Standard.....	17
4.1.5 Test Set Up.....	18
4.1.6 EUT Operating Conditions.....	19
4.1.7 Test Results.....	20
4.2 Conducted Emission Measurement.....	39
4.2.1 Limits of Conducted Emission Measurement.....	39
4.2.2 Test Instruments.....	39
4.2.3 Test Procedures.....	40
4.2.4 Deviation from Test Standard.....	40
4.2.5 Test Setup.....	40
4.2.6 EUT Operating Conditions.....	40
4.2.7 Test Results.....	41
4.3 Transmit Power Measurement.....	43
4.3.1 Limits of Transmit Power Measurement.....	43
4.3.2 Test Setup.....	43
4.3.3 Test Instruments.....	43
4.3.4 Test Procedure.....	44
4.3.5 Deviation from Test Standard.....	44
4.3.6 EUT Operating Conditions.....	44
4.3.7 Test Result.....	45
4.4 Occupied Bandwidth Measurement.....	47
4.4.1 Test Setup.....	47
4.4.2 Test Instruments.....	47
4.4.3 Test Procedure.....	47
4.4.4 Test Result.....	48
4.5 Peak Power Spectral Density Measurement.....	50
4.5.1 Limits of Peak Power Spectral Density Measurement.....	50
4.5.2 Test Setup.....	50
4.5.3 Test Instruments.....	50
4.5.4 Test Procedures.....	50
4.5.5 Deviation from Test Standard.....	51
4.5.6 EUT Operating Conditions.....	51
4.5.7 Test Results.....	52
4.6 Frequency Stability.....	57
4.6.1 Limits of Frequency Stability Measurement.....	57

4.6.2	Test Setup.....	57
4.6.3	Test Procedure	57
4.6.4	Deviation from Test Standard	57
4.6.5	EUT Operating Condition	57
4.6.6	Test Results	58
4.7	6dB Bandwidth Measurement.....	59
4.7.1	Limits of 6dB Bandwidth Measurement.....	59
4.7.2	Test Setup.....	59
4.7.3	Test Instruments	59
4.7.4	Test Procedure	59
4.7.5	Deviation from Test Standard	59
4.7.6	EUT Operating Condition	59
4.7.7	Test Results	60
5	Pictures of Test Arrangements.....	62
	Annex A- Radiated Out of Band Emission (OOBE) Measurement (For U-NII-3 band).....	63
	Appendix – Information on the Testing Laboratories	66

Release Control Record

Issue No.	Description	Date Issued
RF161017C10-1	Original release	Nov. 17, 2016

1 Certificate of Conformity

Product: 802.11 abgn/ac Access Point

Brand: KodaCloud

Test Model: OAP30

Sample Status: Engineering sample

Applicant: KodaCloud, Inc.

Test Date: Oct. 29 ~ Nov. 11, 2016

Standards: 47 CFR FCC Part 15, Subpart E (Section 15.407)
ANSI C63.10:2013

The above equipment has been tested by **Bureau Veritas Consumer Products Services (H.K.) Ltd., Taoyuan Branch**, and found compliance with the requirement of the above standards. The test record, data evaluation & Equipment Under Test (EUT) configurations represented herein are true and accurate accounts of the measurements of the sample's EMC characteristics under the conditions specified in this report.

Prepared by : Celine Chou , **Date:** Nov. 17, 2016
Celine Chou / Specialist

Approved by : Ken Liu , **Date:** Nov. 17, 2016
Ken Liu / Senior Manager

2 Summary of Test Results

47 CFR FCC Part 15, Subpart E (Section 15.407)			
FCC Clause	Test Item	Result	Remarks
15.407(b)(6)	AC Power Conducted Emissions	Pass	Meet the requirement of limit. Minimum passing margin is -5.07dB at 0.52500MHz.
15.407(b)(1/2/3/4(i/ii)/6)	Radiated Emissions & Band Edge Measurement	Pass	Meet the requirement of limit. Minimum passing margin is -1.0dB at 5585.00MHz and 5133.00MHz.
15.407(a)(1/2/3)	Max Average Transmit Power	Pass	Meet the requirement of limit.
---	Occupied Bandwidth Measurement	-	Reference only.
15.407(a)(1/2/3)	Peak Power Spectral Density	Pass	Meet the requirement of limit.
15.407(e)	6dB bandwidth	Pass	Meet the requirement of limit. (U-NII-3 Band only)
15.407(g)	Frequency Stability	Pass	Meet the requirement of limit.
15.203	Antenna Requirement	Pass	Antenna connector is N-Type. (The device is professionally installed)

*For U-NII-3 band compliance with rule part 15.407(b)(4)(i), the OOB test plots were recorded in Annex A.

2.1 Measurement Uncertainty

Where relevant, the following measurement uncertainty levels have been estimated for tests performed on the EUT as specified in CISPR 16-4-2:

Measurement	Frequency	Expanded Uncertainty (k=2) (\pm)
Conducted Emissions at mains ports	150kHz ~ 30MHz	2.44 dB
Radiated Emissions up to 1 GHz	30MHz ~ 200MHz	3.86 dB
	200MHz ~ 1000MHz	3.87 dB
Radiated Emissions above 1 GHz	1GHz ~ 18GHz	2.29 dB
	18GHz ~ 40GHz	2.29 dB

2.2 Modification Record

There were no modifications required for compliance.

3 General Information

3.1 General Description of EUT

Product	802.11 abgn/ac Access Point
Brand	KodaCloud
Test Model	OAP30
Sample Status	Engineering sample
Power Supply Rating	54Vdc (POE)
Modulation Type	256QAM, 64QAM, 16QAM, QPSK, BPSK for OFDM
Modulation Technology	OFDM
Transfer Rate	802.11a: 54.0/ 48.0/ 36.0/ 24.0/ 18.0/ 12.0/ 9.0/ 6.0Mbps 802.11n: up to 450Mbps 802.11ac: up to 1300Mbps
Operating Frequency	5180 ~ 5240MHz, 5745 ~ 5825MHz
Number of Channel	5180 ~ 5240MHz: 4 for 802.11a, 802.11n (HT20), 802.11ac (VHT20) 2 for 802.11n (HT40), 802.11ac (VHT40) 1 for 802.11ac (VHT80) 5745 ~ 5825MHz: 5 for 802.11a, 802.11n (HT20), 802.11ac (VHT20) 2 for 802.11n (HT40), 802.11ac (VHT40) 1 for 802.11ac (VHT80)
Output Power	5180 ~ 5240MHz: 160.418mW 5745 ~ 5825MHz: 441.242mW
Antenna Type	Dipole antenna with 6.0dBi gain
Antenna Connector	N-Type (The device is professionally installed)
Accessory Device	1.8m non-shielded ground cable without core
Data Cable Supplied	NA

Note:

- The EUT incorporates a MIMO function. Physically, the EUT provides 3 completed transmitters and 3 receivers.

Modulation Mode	TX Function
802.11a	3TX
802.11n (HT20)	3TX
802.11n (HT40)	3TX
802.11ac (VHT20)	3TX
802.11ac (VHT40)	3TX
802.11ac (VHT80)	3TX

* The modulation and bandwidth are similar for 802.11n mode for HT20/HT40 and 802.11ac mode for VHT20/VHT40, therefore investigated worst case to representative mode in test report. (Final test mode refer section 3.2.1)

2. The EUT consumes power from the following POE. (support unit only)

Brand	SENAO
Model	EPA5006GAT
Input Power	100-240Vac, 0.8A, 50-60Hz
Output Power	54Vdc, 0.6A
Power Line	0.5m power cable without core

3. The EUT will install at outdoor area, the highest antenna gain from the horizon above 30 degrees as below, for more detail information please refer to antenna specification and user manual

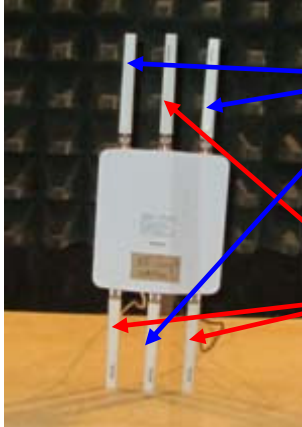
Antenna	Antenna gain	Antenna install degree
Dipole	-3.88 dBi	

4. 2.4GHz and 5GHz technology can transmit at same time.

5. Spurious emission of the simultaneous operation (2.4GHz and 5GHz) has been evaluated and no non-compliance was found.

3.2 Description of Test Modes

For 5180 ~ 5240MHz

4 channels are provided for 802.11a, 802.11n (HT20), 802.11ac (VHT20):

Channel	Frequency	Channel	Frequency
36	5180 MHz	44	5220 MHz
40	5200 MHz	48	5240 MHz

2 channels are provided for 802.11n (HT40), 802.11ac (VHT40):

Channel	Frequency	Channel	Frequency
38	5190 MHz	46	5230 MHz

1 channel is provided for 802.11ac (VHT80):

Channel	Frequency
42	5210MHz

For 5745 ~ 5825MHz:

5 channels are provided for 802.11a, 802.11n (HT20), 802.11ac (VHT20):

Channel	Frequency	Channel	Frequency
149	5745MHz	161	5805MHz
153	5765MHz	165	5825MHz
157	5785MHz		

2 channels are provided for 802.11n (HT40), 802.11ac (VHT40):

Channel	Frequency	Channel	Frequency
151	5755MHz	159	5795MHz

1 channel is provided for 802.11ac (VHT80):

Channel	Frequency
155	5775MHz

3.2.1 Test Mode Applicability and Tested Channel Detail

EUT CONFIGURE MODE	APPLICABLE TO				DESCRIPTION
	RE≥1G	RE<1G	PLC	APCM	
-	√	√	√	√	-

Where **RE≥1G**: Radiated Emission above 1GHz & Bandedge Measurement
RE<1G: Radiated Emission below 1GHz
PLC: Power Line Conducted Emission
APCM: Antenna Port Conducted Measurement

Radiated Emission Test (Above 1GHz):

- Pre-Scan has been conducted to determine the worst-case mode from all possible combinations between available modulations, data rates and antenna ports (if EUT with antenna diversity architecture).
- Following channel(s) was (were) selected for the final test as listed below.

EUT CONFIGURE MODE	MODE	FREQ. BAND (MHz)	AVAILABLE CHANNEL	TESTED CHANNEL	MODULATION TECHNOLOGY	MODULATION TYPE	DATA RATE (Mbps)
-	802.11a	5180-5240	36 to 48	36, 40, 48	OFDM	BPSK	6.0
-	802.11n (HT20)		36 to 48	36, 40, 48	OFDM	BPSK	7.2
-	802.11n (HT40)		38 to 46	38, 46	OFDM	BPSK	15.0
-	802.11ac (VHT80)		42	42	OFDM	BPSK	97.5
-	802.11a	5745-5825	149 to 165	149, 157, 165	OFDM	BPSK	6.0
-	802.11n (HT20)		149 to 165	149, 157, 165	OFDM	BPSK	7.2
-	802.11n (HT40)		151 to 159	151, 159	OFDM	BPSK	15.0
-	802.11ac (VHT80)		155	155	OFDM	BPSK	97.5

Radiated Emission Test (Below 1GHz):

- Pre-Scan has been conducted to determine the worst-case mode from all possible combinations between available modulations, data rates and antenna ports (if EUT with antenna diversity architecture).
- Following channel(s) was (were) selected for the final test as listed below.

EUT CONFIGURE MODE	MODE	FREQ. BAND (MHz)	AVAILABLE CHANNEL	TESTED CHANNEL	MODULATION TECHNOLOGY	MODULATION TYPE	DATA RATE (Mbps)
-	802.11a	5180-5240	36 to 48	36	OFDM	BPSK	6.0
-	802.11a	5745-5825	149 to 165		OFDM	BPSK	6.0

Power Line Conducted Emission Test:

- Pre-Scan has been conducted to determine the worst-case mode from all possible combinations between available modulations, data rates and antenna ports (if EUT with antenna diversity architecture).
- Following channel(s) was (were) selected for the final test as listed below.

EUT CONFIGURE MODE	MODE	FREQ. BAND (MHz)	AVAILABLE CHANNEL	TESTED CHANNEL	MODULATION TECHNOLOGY	MODULATION TYPE	DATA RATE (Mbps)
-	802.11a	5180-5240	36 to 48	36	OFDM	BPSK	6.0
-	802.11a	5745-5825	149 to 165		OFDM	BPSK	6.0

Antenna Port Conducted Measurement:

- This item includes all test value of each mode, but only includes spectrum plot of worst value of each mode.
- Pre-Scan has been conducted to determine the worst-case mode from all possible combinations between available modulations, data rates and antenna ports (if EUT with antenna diversity architecture).
- Following channel(s) was (were) selected for the final test as listed below.

EUT CONFIGURE MODE	MODE	FREQ. BAND (MHz)	AVAILABLE CHANNEL	TESTED CHANNEL	MODULATION TECHNOLOGY	MODULATION TYPE	DATA RATE (Mbps)
-	802.11a	5180-5240	36 to 48	36, 40, 48	OFDM	BPSK	6.0
-	802.11n (HT20)		36 to 48	36, 40, 48	OFDM	BPSK	7.2
-	802.11n (HT40)		38 to 46	38, 46	OFDM	BPSK	15.0
-	802.11ac (VHT80)		42	42	OFDM	BPSK	97.5
-	802.11a	5745-5825	149 to 165	149, 157, 165	OFDM	BPSK	6.0
-	802.11n (HT20)		149 to 165	149, 157, 165	OFDM	BPSK	7.2
-	802.11n (HT40)		151 to 159	151, 159	OFDM	BPSK	15.0
-	802.11ac (VHT80)		155	155	OFDM	BPSK	97.5

Test Condition:

APPLICABLE TO	ENVIRONMENTAL CONDITIONS	INPUT POWER (SYSTEM)	TESTED BY
RE≥1G	20deg. C, 66%RH	120Vac, 60Hz	James Yang
RE<1G	21deg. C, 66%RH	120Vac, 60Hz	Jones Chang
PLC	25deg. C, 68%RH	120Vac, 60Hz	Jones Chang
APCM	25deg. C, 60%RH	120Vac, 60Hz	Nick Hsu

3.3 Duty Cycle of Test Signal

802.11a, 802.11n (HT20): Duty cycle of test signal is > 98 %, duty factor is not required.

802.11n (HT40), 802.11ac (VHT80): Duty cycle of test signal is < 98 %, duty factor is required.

802.11a: Duty cycle = $2.055/2.082 = 0.987$

802.11n (HT20): Duty cycle = $1.912/1.937 = 0.987$

802.11n (HT40): Duty cycle = $0.935/0.965 = 0.969$, Duty factor = $10 * \log(1/0.969) = 0.14$

802.11ac (VHT80): Duty cycle = $0.459/0.477 = 0.962$, Duty factor = $10 * \log(1/0.962) = 0.17$

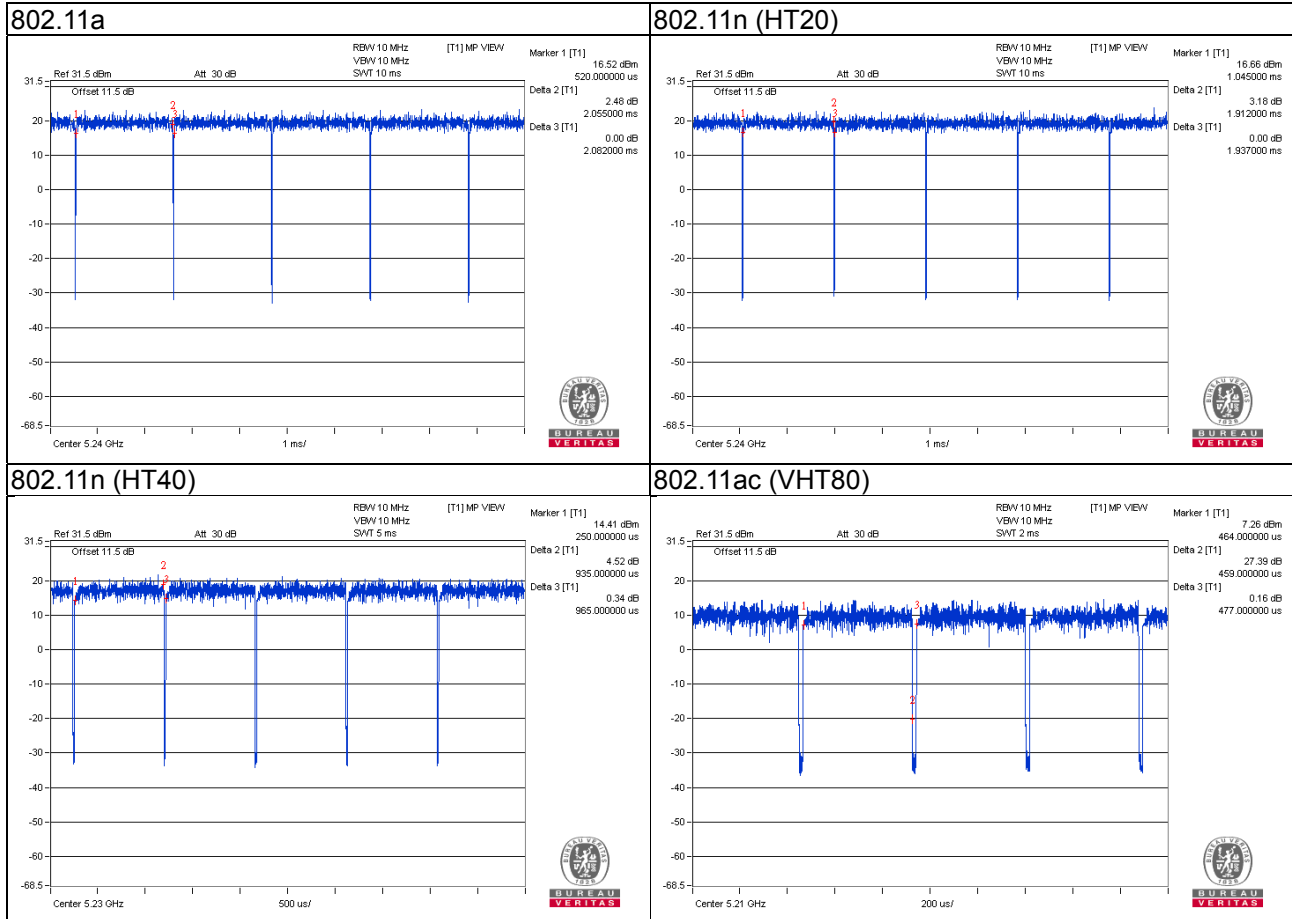

3.4 Description of Support Units

The EUT has been tested as an independent unit together with other necessary accessories or support units. The following support units or accessories were used to form a representative test configuration during the tests.

ID	Product	Brand	Model No.	Serial No.	FCC ID	Remarks
A.	POE	SENAO	EPA5006GAT	NA	NA	Provided by manufacturer
B.	Notebook	DELL	E5410	1HC2XM1	FCC DoC Approved	-
C.	Load	NA	NA	NA	NA	-

Note:

1. All power cords of the above support units are non-shielded (1.8m).
2. Items A-B acted as communication partners to transfer data.

ID	Descriptions	Qty.	Length (m)	Shielding (Yes/No)	Cores (Qty.)	Remarks
1.	LAN cable	1	10	N	0	Cat5e
2.	LAN cable	1	1.8	N	0	Cat5e
3.	LAN cable	1	1.8	N	0	Cat5e

3.4.1 Configuration of System under Test

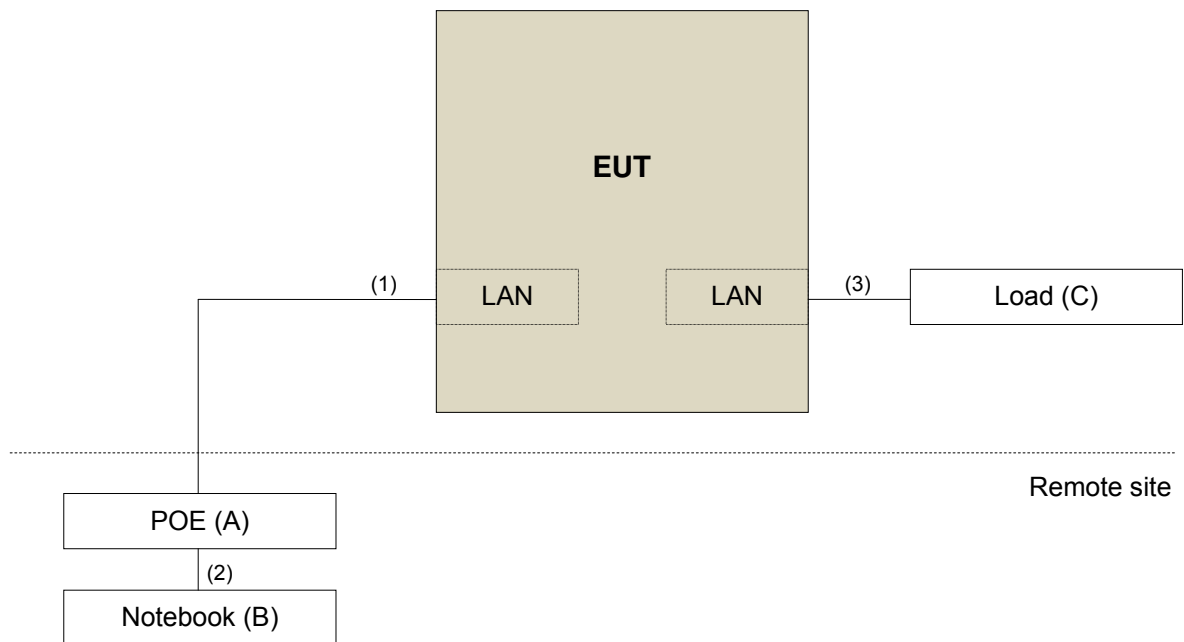

3.5 General Description of Applied Standards

The EUT is a RF Product. According to the specifications of the manufacturer, it must comply with the requirements of the following standards:

FCC Part 15, Subpart E (15.407)

KDB 789033 D02 General UNII Test Procedure New Rules v01r03

KDB 662911 D01 Multiple Transmitter Output v02r01

ANSI C63.10-2013

All test items have been performed and recorded as per the above standards.

Note: The EUT has been verified to comply with the requirements of FCC Part 15, Subpart B, Class B (DoC).
The test report has been issued separately.

4 Test Types and Results

4.1 Radiated Emission and Bandedge Measurement

4.1.1 Limits of Radiated Emission and Bandedge Measurement

Radiated emissions which fall in the restricted bands must comply with the radiated emission limits specified as below table.

Frequencies (MHz)	Field Strength (microvolts/meter)	Measurement Distance (meters)
0.009 ~ 0.490	2400/F(kHz)	300
0.490 ~ 1.705	24000/F(kHz)	30
1.705 ~ 30.0	30	30
30 ~ 88	100	3
88 ~ 216	150	3
216 ~ 960	200	3
Above 960	500	3

NOTE:

- The lower limit shall apply at the transition frequencies.
- Emission level (dBuV/m) = 20 log Emission level (uV/m).
- For frequencies above 1000MHz, the field strength limits are based on average detector, however, the peak field strength of any emission shall not exceed the maximum permitted average limits, specified above by more than 20dB under any condition of modulation.

Limits of unwanted emission out of the restricted bands

Applicable To		Limit	
789033 D02 General UNII Test Procedure New Rules v01r03		Field Strength at 3m	
		PK:74 (dBuV/m)	AV:54 (dBuV/m)
Frequency Band	Applicable To	EIRP Limit	Equivalent Field Strength at 3m
5150~5250 MHz	15.407(b)(1)	PK:-27 (dBm/MHz)	PK:68.2(dBuV/m)
5250~5350 MHz	15.407(b)(2)		
5470~5725 MHz	15.407(b)(3)		
5725~5850 MHz	<input checked="" type="checkbox"/> 15.407(b)(4)(i)	PK:-27 (dBm/MHz) ^{*1} PK:10 (dBm/MHz) ^{*2} PK:15.6 (dBm/MHz) ^{*3} PK:27 (dBm/MHz) ^{*4}	PK: 68.2(dBuV/m) ^{*1} PK:105.2 (dBuV/m) ^{*2} PK: 110.8(dBuV/m) ^{*3} PK:122.2 (dBuV/m) ^{*4}
	<input type="checkbox"/> 15.407(b)(4)(ii)	Emission limits in section 15.247(d)	
^{*1} beyond 75 MHz or more above of the band edge.		^{*2} below the band edge increasing linearly to 10 dBm/MHz at 25 MHz above.	
^{*3} below the band edge increasing linearly to a level of 15.6 dBm/MHz at 5 MHz above.		^{*4} from 5 MHz above or below the band edge increasing linearly to a level of 27 dBm/MHz at the band edge.	

Note: The following formula is used to convert the equipment isotropic radiated power (eirp) to field strength:

$$E = \frac{1000000\sqrt{30P}}{3} \mu\text{V/m, where P is the eirp (Watts).}$$

4.1.2 Test Instruments

Description & Manufacturer	Model No.	Serial No.	Cal. Date	Cal. Due
Test Receiver ROHDE & SCHWARZ	ESIB7	100187	Apr. 18, 2016	Apr. 17, 2017
Spectrum Analyzer ROHDE & SCHWARZ	FSP40	100041	Sep. 02, 2016	Sep. 01, 2017
BILOG Antenna SCHWARZBECK	VULB9168	9168-171	Jan. 07, 2016	Jan. 06, 2017
HORN Antenna SCHWARZBECK	9120D	209	Jan. 20, 2016	Jan. 19, 2017
HORN Antenna SCHWARZBECK	BBHA 9170	BBHA9170241	Jan. 18, 2016	Jan. 17, 2017
Loop Antenna	EM-6879	269	Aug. 11, 2016	Aug. 10, 2017
Preamplifier Agilent	8447D	2944A10738	Aug. 22, 2016	Aug. 21, 2017
Preamplifier Agilent	8449B	3008A01964	Aug. 22, 2016	Aug. 21, 2017
RF signal cable HUBER+SUHNER	SUCOFLEX 104	Cable-CH3-03 (214378)	Aug. 22, 2016	Aug. 21, 2017
RF signal cable HUBER+SUHNER	SUCOFLEX 106	Cable-CH3-03 (309224+12738)	Aug. 22, 2016	Aug. 21, 2017
Software BV ADT	ADT_Radiated_ V7.6.15.9.4	NA	NA	NA
Antenna Tower inn-co GmbH	MA 4000	013303	NA	NA
Antenna Tower Controller BV ADT	AT100	AT93021702	NA	NA
Turn Table BV ADT	TT100	TT93021702	NA	NA
Turn Table Controller BV ADT	SC100	SC93021702	NA	NA
26GHz ~ 40GHz Amplifier	EM26400	815221	Oct. 17, 2016	Oct. 16, 2017
High Speed Peak Power Meter	ML2495A	0824011	Jul. 09, 2016	Jul. 08, 2017
Power Sensor	MA2411B	0738171	Aug. 11, 2016	Aug. 10, 2017
WIT Standard Temperature And Humidity Chamber	TH-4S-C	W981030	Jun. 08, 2016	Jun. 07, 2017
Mini-Circuits Power Splitter	ZN2PD-9G	NA	Jun. 09, 2016	Jun. 08, 2017

- Note:
1. The calibration interval of the above test instruments is 12 months and the calibrations are traceable to NML/ROC and NIST/USA.
 2. The test was performed in HwaYa Chamber 3.
 3. The horn antenna and preamplifier (model: 8449B) are used only for the measurement of emission frequency above 1GHz if tested.
 4. The FCC Site Registration No. is 988962.
 5. The IC Site Registration No. is IC 7450F-3.

4.1.3 Test Procedures

For Radiated emission below 30MHz

- a. The EUT was placed on the top of a rotating table 0.8 meters above the ground at a 3 meter chamber room. The table was rotated 360 degrees to determine the position of the highest radiation.
- b. The EUT was set 3 meters away from the interference-receiving antenna, which was mounted on the top of a variable-height antenna tower.
- c. Both X and Y axes of the antenna are set to make the measurement.
- d. For each suspected emission, the EUT was arranged to its worst case and the rotatable table was turned from 0 degrees to 360 degrees to find the maximum reading.
- e. The test-receiver system was set to Quasi-Peak Detect Function and Specified Bandwidth with Maximum Hold Mode.

Note:

1. The resolution bandwidth and video bandwidth of test receiver/spectrum analyzer is 9kHz at frequency below 30MHz.

For Radiated emission above 30MHz

- a. The EUT was placed on the top of a rotating table 0.8 meters (for 30MHz ~ 1GHz) / 1.5 meters (for above 1GHz) above the ground at 3 meter chamber room for test. The table was rotated 360 degrees to determine the position of the highest radiation.
- b. The EUT was set 3 meters away from the interference-receiving antenna, which was mounted on the top of a variable-height antenna tower.
- c. The height of antenna is varied from one meter to four meters above the ground to determine the maximum value of the field strength. Both horizontal and vertical polarizations of the antenna are set to make the measurement.
- d. For each suspected emission, the EUT was arranged to its worst case and then the antenna was tuned to heights from 1 meter to 4 meters and the rotatable table was turned from 0 degrees to 360 degrees to find the maximum reading.
- e. The test-receiver system was set to quasi-peak detect function and specified bandwidth with maximum hold mode when the test frequency is below 1 GHz.
- f. The test-receiver system was set to peak and average detect function and specified bandwidth with maximum hold mode when the test frequency is above 1 GHz. If the peak reading value also meets average limit, measurement with the average detector is unnecessary.

Note:

1. The resolution bandwidth and video bandwidth of test receiver/spectrum analyzer is 120kHz for Quasi-peak detection (QP) at frequency below 1GHz.
2. The resolution bandwidth of test receiver/spectrum analyzer is 1 MHz and the video bandwidth is 3 MHz for Peak detection (PK) at frequency above 1GHz.
3. The resolution bandwidth of test receiver/spectrum analyzer is 1MHz and the video bandwidth is $\geq 1/T$ (Duty cycle < 98%) or 10Hz (Duty cycle $\geq 98\%$) for Average detection (AV) at frequency above 1GHz.
4. All modes of operation were investigated and the worst-case emissions are reported.

4.1.4 Deviation from Test Standard

No deviation.

4.1.5 Test Set Up

For Radiated emission below 30MHz

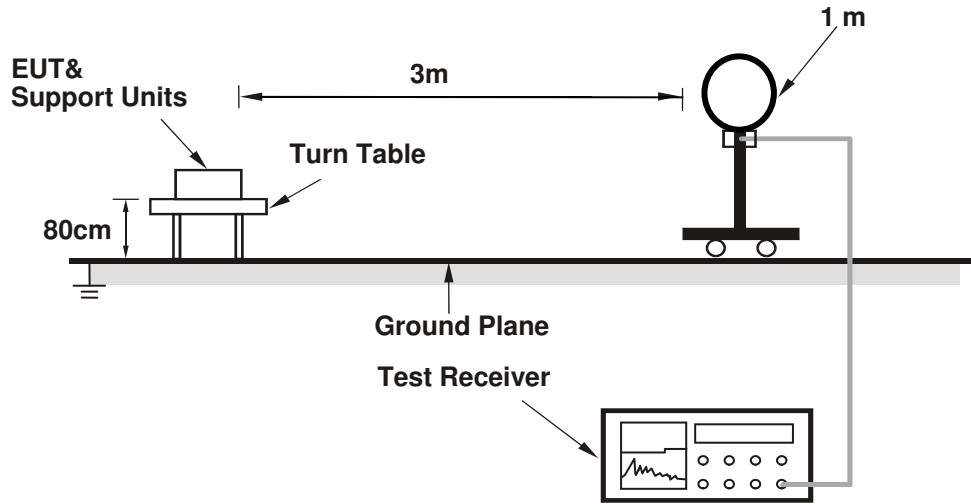

For Radiated emission 30MHz to 1GHz

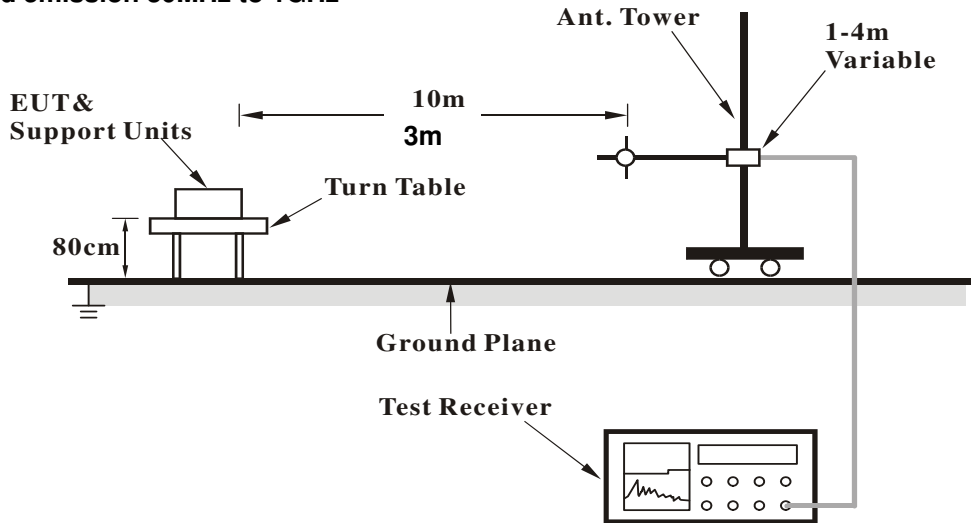

For Radiated emission above 1GHz

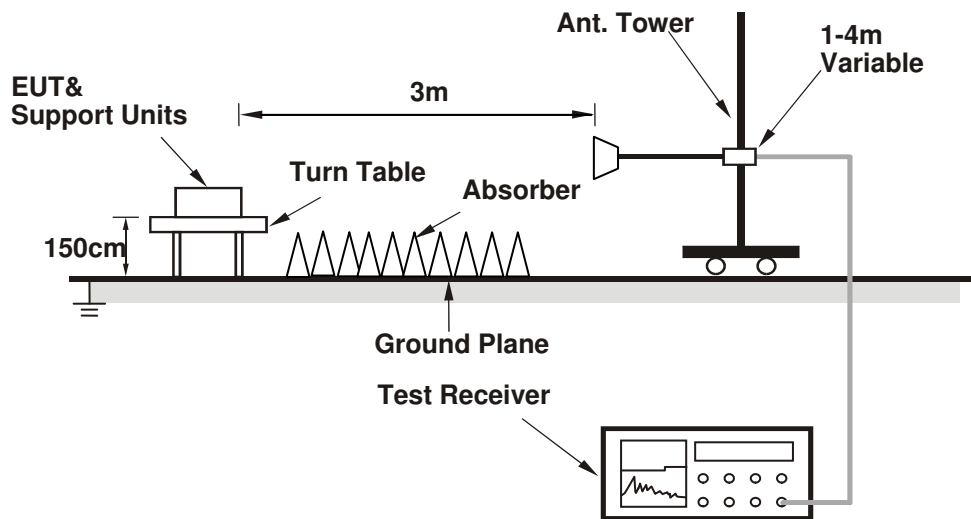

For the actual test configuration, please refer to the attached file (Test Setup Photo).

4.1.6 EUT Operating Conditions

- Placed the EUT on the testing table.
- Prepared a notebook to act as a communication partner and placed it outside of testing area.
- The communication partner connected with EUT via a RJ45 cable and ran a test program (provided by manufacturer) to enable EUT under transmission condition continuously at specific channel frequency.
- The communication partner sent data to EUT by command "PING".

4.1.7 Test Results

Above 1GHz worst-Case Data:

802.11a

CHANNEL	TX Channel 36	DETECTOR	Peak (PK)
FREQUENCY RANGE	1GHz ~ 40GHz	FUNCTION	Average (AV)

ANTENNA POLARITY & TEST DISTANCE: HORIZONTAL AT 3 M								
NO.	FREQ. (MHz)	EMISSION LEVEL (dBuV/m)	LIMIT (dBuV/m)	MARGIN (dB)	ANTENNA HEIGHT (m)	TABLE ANGLE (Degree)	RAW VALUE (dBuV)	CORRECTION FACTOR (dB/m)
1	5020.00	56.1 PK	74.0	-17.9	1.92 H	112	51.8	4.3
2	5020.00	45.1 AV	54.0	-8.9	1.92 H	112	40.8	4.3
3	5100.00	55.5 PK	74.0	-18.5	1.66 H	80	50.9	4.6
4	5100.00	45.0 AV	54.0	-9.0	1.66 H	80	40.4	4.6
5	*5180.00	101.9 PK			1.61 H	198	63.2	38.7
6	*5180.00	92.3 AV			1.61 H	198	53.6	38.7
7	5395.00	57.4 PK	74.0	-16.6	1.80 H	79	51.9	5.5
8	5395.00	46.4 AV	54.0	-7.6	1.80 H	79	40.9	5.5
9	#10360.00	59.1 PK	74.0	-14.9	2.22 H	20	41.5	17.6
10	#10360.00	46.4 AV	54.0	-7.6	2.22 H	20	28.8	17.6

ANTENNA POLARITY & TEST DISTANCE: VERTICAL AT 3 M								
NO.	FREQ. (MHz)	EMISSION LEVEL (dBuV/m)	LIMIT (dBuV/m)	MARGIN (dB)	ANTENNA HEIGHT (m)	TABLE ANGLE (Degree)	RAW VALUE (dBuV)	CORRECTION FACTOR (dB/m)
1	5019.00	63.0 PK	74.0	-11.0	1.92 V	9	58.7	4.3
2	5019.00	52.8 AV	54.0	-1.2	1.92 V	9	48.5	4.3
3	5100.00	64.0 PK	74.0	-10.0	1.89 V	6	59.4	4.6
4	5100.00	52.3 AV	54.0	-1.7	1.89 V	6	47.7	4.6
5	*5180.00	117.9 PK			1.57 V	15	79.2	38.7
6	*5180.00	108.7 AV			1.57 V	15	70.0	38.7
7	5395.00	61.0 PK	74.0	-13.0	1.60 V	327	55.5	5.5
8	5395.00	52.7 AV	54.0	-1.3	1.60 V	327	47.2	5.5
9	#10360.00	59.3 PK	74.0	-14.7	1.73 V	288	41.7	17.6
10	#10360.00	46.6 AV	54.0	-7.4	1.73 V	288	29.0	17.6

Remarks:

1. Emission Level(dBuV/m) = Raw Value(dBuV) + Correction Factor(dB/m)
2. Correction Factor(dB/m) = Antenna Factor(dB/m) + Cable Factor(dB) – Pre-Amplifier Factor(dB)
3. The other emission levels were very low against the limit.
4. Margin value = Emission Level – Limit value
5. " * ": Fundamental frequency.
6. " # ": The radiated frequency is out of the restricted band.

CHANNEL	TX Channel 40	DETECTOR FUNCTION	Peak (PK)
FREQUENCY RANGE	1GHz ~ 40GHz		Average (AV)

ANTENNA POLARITY & TEST DISTANCE: HORIZONTAL AT 3 M								
NO.	FREQ. (MHz)	EMISSION LEVEL (dBuV/m)	LIMIT (dBuV/m)	MARGIN (dB)	ANTENNA HEIGHT (m)	TABLE ANGLE (Degree)	RAW VALUE (dBuV)	CORRECTION FACTOR (dB/m)
1	5040.00	56.2 PK	74.0	-17.8	1.95 H	118	51.8	4.4
2	5040.00	45.0 AV	54.0	-9.0	1.95 H	118	40.6	4.4
3	5119.00	56.8 PK	74.0	-17.2	2.00 H	41	52.0	4.8
4	5119.00	45.7 AV	54.0	-8.3	2.00 H	41	40.9	4.8
5	*5200.00	95.0 PK			2.51 H	25	56.3	38.7
6	*5200.00	86.3 AV			2.51 H	25	47.6	38.7
7	5359.00	58.6 PK	74.0	-15.4	2.06 H	168	53.1	5.5
8	5359.00	46.5 AV	54.0	-7.5	2.06 H	168	41.0	5.5
9	#10400.00	59.9 PK	74.0	-14.1	2.11 H	150	42.3	17.6
10	#10400.00	46.5 AV	54.0	-7.5	2.11 H	150	28.9	17.6

ANTENNA POLARITY & TEST DISTANCE: VERTICAL AT 3 M								
NO.	FREQ. (MHz)	EMISSION LEVEL (dBuV/m)	LIMIT (dBuV/m)	MARGIN (dB)	ANTENNA HEIGHT (m)	TABLE ANGLE (Degree)	RAW VALUE (dBuV)	CORRECTION FACTOR (dB/m)
1	5040.00	62.8 PK	74.0	-11.2	1.92 V	8	58.4	4.4
2	5040.00	51.7 AV	54.0	-2.3	1.92 V	8	47.3	4.4
3	5119.00	64.4 PK	74.0	-9.6	1.92 V	8	59.6	4.8
4	5119.00	52.7 AV	54.0	-1.3	1.92 V	8	47.9	4.8
5	*5200.00	117.0 PK			1.93 V	15	78.3	38.7
6	*5200.00	108.2 AV			1.93 V	15	69.5	38.7
7	5359.00	63.2 PK	74.0	-10.8	1.92 V	15	57.7	5.5
8	5359.00	52.3 AV	54.0	-1.7	1.92 V	15	46.8	5.5
9	#10400.00	60.5 PK	74.0	-13.5	1.28 V	333	42.9	17.6
10	#10400.00	46.7 AV	54.0	-7.3	1.28 V	333	29.1	17.6

Remarks:

1. Emission Level(dBuV/m) = Raw Value(dBuV) + Correction Factor(dB/m)
2. Correction Factor(dB/m) = Antenna Factor(dB/m) + Cable Factor(dB) – Pre-Amplifier Factor(dB)
3. The other emission levels were very low against the limit.
4. Margin value = Emission Level – Limit value
5. " * ": Fundamental frequency.
6. " # ": The radiated frequency is out of the restricted band.

CHANNEL	TX Channel 48	DETECTOR FUNCTION	Peak (PK)
FREQUENCY RANGE	1GHz ~ 40GHz		Average (AV)

ANTENNA POLARITY & TEST DISTANCE: HORIZONTAL AT 3 M								
NO.	FREQ. (MHz)	EMISSION LEVEL (dBuV/m)	LIMIT (dBuV/m)	MARGIN (dB)	ANTENNA HEIGHT (m)	TABLE ANGLE (Degree)	RAW VALUE (dBuV)	CORRECTION FACTOR (dB/m)
1	5080.00	55.9 PK	74.0	-18.1	1.71 H	219	51.3	4.6
2	5080.00	45.1 AV	54.0	-8.9	1.71 H	219	40.5	4.6
3	*5240.00	100.9 PK			2.19 H	141	62.0	38.9
4	*5240.00	91.0 AV			2.19 H	141	52.1	38.9
5	5400.00	56.0 PK	74.0	-18.0	1.56 H	220	50.5	5.5
6	5400.00	45.7 AV	54.0	-8.3	1.56 H	220	40.2	5.5
7	#10480.00	60.0 PK	74.0	-14.0	2.15 H	273	41.6	18.4
8	#10480.00	47.0 AV	54.0	-7.0	2.15 H	273	28.6	18.4

ANTENNA POLARITY & TEST DISTANCE: VERTICAL AT 3 M								
NO.	FREQ. (MHz)	EMISSION LEVEL (dBuV/m)	LIMIT (dBuV/m)	MARGIN (dB)	ANTENNA HEIGHT (m)	TABLE ANGLE (Degree)	RAW VALUE (dBuV)	CORRECTION FACTOR (dB/m)
1	5080.00	62.8 PK	74.0	-11.2	1.96 V	189	58.2	4.6
2	5080.00	52.6 AV	54.0	-1.4	1.96 V	189	48.0	4.6
3	*5240.00	116.3 PK			1.79 V	10	77.4	38.9
4	*5240.00	108.2 AV			1.79 V	10	69.3	38.9
5	5398.00	63.1 PK	74.0	-10.9	1.95 V	192	57.6	5.5
6	5398.00	52.1 AV	54.0	-1.9	1.95 V	192	46.6	5.5
7	#10480.00	61.1 PK	74.0	-12.9	2.12 V	174	42.7	18.4
8	#10480.00	48.0 AV	54.0	-6.0	2.12 V	174	29.6	18.4

Remarks:

1. Emission Level(dBuV/m) = Raw Value(dBuV) + Correction Factor(dB/m)
2. Correction Factor(dB/m) = Antenna Factor(dB/m) + Cable Factor(dB) – Pre-Amplifier Factor(dB)
3. The other emission levels were very low against the limit.
4. Margin value = Emission Level – Limit value
5. " * ": Fundamental frequency.
6. " # ": The radiated frequency is out of the restricted band.

CHANNEL	TX Channel 149	DETECTOR FUNCTION	Peak (PK)
FREQUENCY RANGE	1GHz ~ 40GHz		Average (AV)

ANTENNA POLARITY & TEST DISTANCE: HORIZONTAL AT 3 M								
NO.	FREQ. (MHz)	EMISSION LEVEL (dBuV/m)	LIMIT (dBuV/m)	MARGIN (dB)	ANTENNA HEIGHT (m)	TABLE ANGLE (Degree)	RAW VALUE (dBuV)	CORRECTION FACTOR (dB/m)
1	#5585.00	56.4 PK	68.2	-11.8	1.70 H	200	50.3	6.1
2	#5619.20	58.2 PK	68.2	-10.0	1.78 H	209	52.1	6.1
3	*5745.00	104.3 PK			1.78 H	209	64.3	40.0
4	*5745.00	94.6 AV			1.78 H	209	54.6	40.0
5	#5944.80	59.1 PK	68.2	-9.1	1.78 H	209	52.5	6.6
6	11490.00	60.8 PK	74.0	-13.2	1.31 H	279	41.5	19.3
7	11490.00	47.8 AV	54.0	-6.2	1.31 H	279	28.5	19.3

ANTENNA POLARITY & TEST DISTANCE: VERTICAL AT 3 M								
NO.	FREQ. (MHz)	EMISSION LEVEL (dBuV/m)	LIMIT (dBuV/m)	MARGIN (dB)	ANTENNA HEIGHT (m)	TABLE ANGLE (Degree)	RAW VALUE (dBuV)	CORRECTION FACTOR (dB/m)
1	#5585.00	67.2 PK	68.2	-1.0	1.64 V	352	61.1	6.1
2	#5628.00	61.0 PK	68.2	-7.2	1.64 V	346	54.9	6.1
3	*5745.00	120.4 PK			1.64 V	346	80.4	40.0
4	*5745.00	110.7 AV			1.64 V	346	70.7	40.0
5	#5983.20	61.3 PK	68.2	-6.9	1.64 V	346	54.6	6.7
6	11490.00	61.5 PK	74.0	-12.5	1.93 V	255	42.2	19.3
7	11490.00	48.6 AV	54.0	-5.4	1.93 V	255	29.3	19.3

Remarks:

1. Emission Level(dBuV/m) = Raw Value(dBuV) + Correction Factor(dB/m)
2. Correction Factor(dB/m) = Antenna Factor(dB/m) + Cable Factor(dB) – Pre-Amplifier Factor(dB)
3. The other emission levels were very low against the limit.
4. Margin value = Emission Level – Limit value
5. " * ": Fundamental frequency.
6. " # ": The radiated frequency is out of the restricted band.

CHANNEL	TX Channel 157	DETECTOR FUNCTION	Peak (PK)
FREQUENCY RANGE	1GHz ~ 40GHz		Average (AV)

ANTENNA POLARITY & TEST DISTANCE: HORIZONTAL AT 3 M								
NO.	FREQ. (MHz)	EMISSION LEVEL (dBuV/m)	LIMIT (dBuV/m)	MARGIN (dB)	ANTENNA HEIGHT (m)	TABLE ANGLE (Degree)	RAW VALUE (dBuV)	CORRECTION FACTOR (dB/m)
1	#5612.00	58.5 PK	68.2	-9.7	1.71 H	211	52.4	6.1
2	#5625.00	57.1 PK	68.2	-11.1	1.68 H	290	51.0	6.1
3	*5785.00	103.6 PK			1.71 H	211	63.5	40.1
4	*5785.00	93.8 AV			1.71 H	211	53.7	40.1
5	#5945.00	57.2 PK	68.2	-11.0	1.65 H	321	50.6	6.6
6	#5995.20	58.4 PK	68.2	-9.8	1.71 H	211	51.7	6.7
7	11570.00	60.5 PK	74.0	-13.5	1.21 H	299	41.3	19.2
8	11570.00	47.6 AV	54.0	-6.4	1.21 H	299	28.4	19.2

ANTENNA POLARITY & TEST DISTANCE: VERTICAL AT 3 M								
NO.	FREQ. (MHz)	EMISSION LEVEL (dBuV/m)	LIMIT (dBuV/m)	MARGIN (dB)	ANTENNA HEIGHT (m)	TABLE ANGLE (Degree)	RAW VALUE (dBuV)	CORRECTION FACTOR (dB/m)
1	#5622.40	65.7 PK	68.2	-2.5	1.64 V	346	59.6	6.1
2	#5625.00	66.8 PK	68.2	-1.4	1.61 V	348	60.7	6.1
3	*5785.00	120.4 PK			1.64 V	346	80.3	40.1
4	*5785.00	110.9 AV			1.64 V	346	70.8	40.1
5	#5943.20	63.5 PK	68.2	-4.7	1.64 V	346	56.9	6.6
6	#5945.00	64.7 PK	68.2	-3.5	1.71 V	300	58.1	6.6
7	11570.00	61.7 PK	74.0	-12.3	1.86 V	56	42.5	19.2
8	11570.00	48.6 AV	54.0	-5.4	1.86 V	56	29.4	19.2

Remarks:

1. Emission Level(dBuV/m) = Raw Value(dBuV) + Correction Factor(dB/m)
2. Correction Factor(dB/m) = Antenna Factor(dB/m) + Cable Factor(dB) – Pre-Amplifier Factor(dB)
3. The other emission levels were very low against the limit.
4. Margin value = Emission Level – Limit value
5. " * ": Fundamental frequency.

CHANNEL	TX Channel 165	DETECTOR FUNCTION	Peak (PK)
FREQUENCY RANGE	1GHz ~ 40GHz		Average (AV)

ANTENNA POLARITY & TEST DISTANCE: HORIZONTAL AT 3 M								
NO.	FREQ. (MHz)	EMISSION LEVEL (dBuV/m)	LIMIT (dBuV/m)	MARGIN (dB)	ANTENNA HEIGHT (m)	TABLE ANGLE (Degree)	RAW VALUE (dBuV)	CORRECTION FACTOR (dB/m)
1	#5585.00	56.5 PK	68.2	-11.7	1.60 H	144	50.4	6.1
2	#5609.60	57.9 PK	68.2	-10.3	1.66 H	207	51.8	6.1
3	*5825.00	106.2 PK			1.66 H	207	66.1	40.1
4	*5825.00	96.3 AV			1.66 H	207	56.2	40.1
5	#5980.00	58.7 PK	68.2	-9.5	1.66 H	207	52.0	6.7
6	#5985.00	57.1 PK	68.2	-11.1	1.60 H	150	50.4	6.7
7	11650.00	62.3 PK	74.0	-11.7	1.26 H	300	43.0	19.3
8	11650.00	49.4 AV	54.0	-4.6	1.26 H	300	30.1	19.3

ANTENNA POLARITY & TEST DISTANCE: VERTICAL AT 3 M								
NO.	FREQ. (MHz)	EMISSION LEVEL (dBuV/m)	LIMIT (dBuV/m)	MARGIN (dB)	ANTENNA HEIGHT (m)	TABLE ANGLE (Degree)	RAW VALUE (dBuV)	CORRECTION FACTOR (dB/m)
1	#5585.00	64.8 PK	68.2	-3.4	1.66 V	348	58.7	6.1
2	#5662.40	67.3 PK	77.4	-10.1	1.66 V	349	61.2	6.1
3	*5825.00	122.1 PK			1.66 V	349	82.0	40.1
4	*5825.00	112.4 AV			1.66 V	349	72.3	40.1
5	#5982.40	65.0 PK	68.2	-3.2	1.66 V	349	58.3	6.7
6	#5985.00	66.8 PK	68.2	-1.4	1.64 V	346	60.1	6.7
7	11650.00	62.3 PK	74.0	-11.7	1.81 V	49	43.0	19.3
8	11650.00	49.2 AV	54.0	-4.8	1.81 V	49	29.9	19.3

Remarks:

1. Emission Level(dBuV/m) = Raw Value(dBuV) + Correction Factor(dB/m)
2. Correction Factor(dB/m) = Antenna Factor(dB/m) + Cable Factor(dB) – Pre-Amplifier Factor(dB)
3. The other emission levels were very low against the limit.
4. Margin value = Emission Level – Limit value
5. " * ": Fundamental frequency.
6. " # ": The radiated frequency is out of the restricted band.

802.11n (HT20)

CHANNEL	TX Channel 36	DETECTOR FUNCTION	Peak (PK)
FREQUENCY RANGE	1GHz ~ 40GHz		Average (AV)

ANTENNA POLARITY & TEST DISTANCE: HORIZONTAL AT 3 M

NO.	FREQ. (MHz)	EMISSION LEVEL (dBuV/m)	LIMIT (dBuV/m)	MARGIN (dB)	ANTENNA HEIGHT (m)	TABLE ANGLE (Degree)	RAW VALUE (dBuV)	CORRECTION FACTOR (dB/m)
1	5090.00	55.8 PK	74.0	-18.2	1.88 H	188	51.2	4.6
2	5090.00	45.0 AV	54.0	-9.0	1.88 H	188	40.4	4.6
3	5100.00	56.3 PK	74.0	-17.7	1.50 H	272	51.7	4.6
4	5100.00	45.3 AV	54.0	-8.7	1.50 H	272	40.7	4.6
5	*5180.00	102.6 PK			2.02 H	137	63.9	38.7
6	*5180.00	92.6 AV			2.02 H	137	53.9	38.7
7	5395.00	57.1 PK	74.0	-16.9	2.00 H	262	51.6	5.5
8	5395.00	46.1 AV	54.0	-7.9	2.00 H	262	40.6	5.5
9	#10360.00	59.3 PK	74.0	-14.7	1.69 H	279	41.7	17.6
10	#10360.00	46.3 AV	54.0	-7.7	1.69 H	279	28.7	17.6

ANTENNA POLARITY & TEST DISTANCE: VERTICAL AT 3 M

NO.	FREQ. (MHz)	EMISSION LEVEL (dBuV/m)	LIMIT (dBuV/m)	MARGIN (dB)	ANTENNA HEIGHT (m)	TABLE ANGLE (Degree)	RAW VALUE (dBuV)	CORRECTION FACTOR (dB/m)
1	5090.00	63.0 PK	74.0	-11.0	1.92 V	324	58.4	4.6
2	5090.00	52.2 AV	54.0	-1.8	1.92 V	324	47.6	4.6
3	5100.00	63.8 PK	74.0	-10.2	1.59 V	327	59.2	4.6
4	5100.00	51.7 AV	54.0	-2.3	1.59 V	327	47.1	4.6
5	*5180.00	118.4 PK			1.65 V	324	79.7	38.7
6	*5180.00	108.4 AV			1.65 V	324	69.7	38.7
7	5395.00	60.5 PK	74.0	-13.5	1.53 V	189	55.0	5.5
8	5395.00	50.7 AV	54.0	-3.3	1.53 V	189	45.2	5.5
9	#10360.00	60.1 PK	74.0	-13.9	1.99 V	197	42.5	17.6
10	#10360.00	46.9 AV	54.0	-7.1	1.99 V	197	29.3	17.6

Remarks:

1. Emission Level(dBuV/m) = Raw Value(dBuV) + Correction Factor(dB/m)
2. Correction Factor(dB/m) = Antenna Factor(dB/m) + Cable Factor(dB) – Pre-Amplifier Factor(dB)
3. The other emission levels were very low against the limit.
4. Margin value = Emission Level – Limit value
5. " * ": Fundamental frequency.
6. " # ": The radiated frequency is out of the restricted band.

CHANNEL	TX Channel 40	DETECTOR FUNCTION	Peak (PK)
FREQUENCY RANGE	1GHz ~ 40GHz		Average (AV)

ANTENNA POLARITY & TEST DISTANCE: HORIZONTAL AT 3 M								
NO.	FREQ. (MHz)	EMISSION LEVEL (dBuV/m)	LIMIT (dBuV/m)	MARGIN (dB)	ANTENNA HEIGHT (m)	TABLE ANGLE (Degree)	RAW VALUE (dBuV)	CORRECTION FACTOR (dB/m)
1	5040.00	55.8 PK	74.0	-18.2	1.87 H	0	51.4	4.4
2	5040.00	44.8 AV	54.0	-9.2	1.87 H	0	40.4	4.4
3	5120.00	56.5 PK	74.0	-17.5	2.01 H	36	51.7	4.8
4	5120.00	45.3 AV	54.0	-8.7	2.01 H	36	40.5	4.8
5	*5200.00	101.9 PK			1.97 H	141	63.2	38.7
6	*5200.00	91.4 AV			1.97 H	141	52.7	38.7
7	5359.00	58.6 PK	74.0	-15.4	2.12 H	254	53.1	5.5
8	5359.00	47.4 AV	54.0	-6.6	2.12 H	254	41.9	5.5
9	#10400.00	60.8 PK	74.0	-13.2	2.30 H	177	43.2	17.6
10	#10400.00	47.6 AV	54.0	-6.4	2.30 H	177	30.0	17.6

ANTENNA POLARITY & TEST DISTANCE: VERTICAL AT 3 M								
NO.	FREQ. (MHz)	EMISSION LEVEL (dBuV/m)	LIMIT (dBuV/m)	MARGIN (dB)	ANTENNA HEIGHT (m)	TABLE ANGLE (Degree)	RAW VALUE (dBuV)	CORRECTION FACTOR (dB/m)
1	5040.00	63.0 PK	74.0	-11.0	1.56 V	328	58.6	4.4
2	5040.00	52.7 AV	54.0	-1.3	1.56 V	328	48.3	4.4
3	5120.00	62.5 PK	74.0	-11.5	1.70 V	6	57.7	4.8
4	5120.00	51.7 AV	54.0	-2.3	1.70 V	6	46.9	4.8
5	*5200.00	116.9 PK			1.64 V	324	78.2	38.7
6	*5200.00	107.1 AV			1.64 V	324	68.4	38.7
7	5359.00	63.0 PK	74.0	-11.0	1.65 V	191	57.5	5.5
8	5359.00	52.2 AV	54.0	-1.8	1.65 V	191	46.7	5.5
9	5416.00	60.4 PK	74.0	-13.6	1.52 V	324	54.7	5.7
10	5416.00	52.3 AV	54.0	-1.7	1.52 V	324	46.6	5.7
11	#10400.00	60.3 PK	74.0	-13.7	1.33 V	343	42.7	17.6
12	#10400.00	47.1 AV	54.0	-6.9	1.33 V	343	29.5	17.6

Remarks:

1. Emission Level(dBuV/m) = Raw Value(dBuV) + Correction Factor(dB/m)
2. Correction Factor(dB/m) = Antenna Factor(dB/m) + Cable Factor(dB) – Pre-Amplifier Factor(dB)
3. The other emission levels were very low against the limit.
4. Margin value = Emission Level – Limit value
5. " * ": Fundamental frequency.
6. " # ": The radiated frequency is out of the restricted band.

CHANNEL	TX Channel 48	DETECTOR FUNCTION	Peak (PK)
FREQUENCY RANGE	1GHz ~ 40GHz		Average (AV)

ANTENNA POLARITY & TEST DISTANCE: HORIZONTAL AT 3 M								
NO.	FREQ. (MHz)	EMISSION LEVEL (dBuV/m)	LIMIT (dBuV/m)	MARGIN (dB)	ANTENNA HEIGHT (m)	TABLE ANGLE (Degree)	RAW VALUE (dBuV)	CORRECTION FACTOR (dB/m)
1	5080.00	56.0 PK	74.0	-18.0	1.88 H	289	51.4	4.6
2	5080.00	44.9 AV	54.0	-9.1	1.88 H	289	40.3	4.6
3	*5240.00	101.8 PK			2.14 H	141	62.9	38.9
4	*5240.00	91.5 AV			2.14 H	141	52.6	38.9
5	5398.00	57.6 PK	74.0	-16.4	2.00 H	79	52.1	5.5
6	5398.00	47.4 AV	54.0	-6.6	2.00 H	79	41.9	5.5
7	#10480.00	60.1 PK	74.0	-13.9	1.67 H	100	41.7	18.4
8	#10480.00	47.0 AV	54.0	-7.0	1.67 H	100	28.6	18.4

ANTENNA POLARITY & TEST DISTANCE: VERTICAL AT 3 M								
NO.	FREQ. (MHz)	EMISSION LEVEL (dBuV/m)	LIMIT (dBuV/m)	MARGIN (dB)	ANTENNA HEIGHT (m)	TABLE ANGLE (Degree)	RAW VALUE (dBuV)	CORRECTION FACTOR (dB/m)
1	5080.00	63.1 PK	74.0	-10.9	1.66 V	5	58.5	4.6
2	5080.00	52.3 AV	54.0	-1.7	1.66 V	5	47.7	4.6
3	*5240.00	117.3 PK			1.51 V	13	78.4	38.9
4	*5240.00	107.6 AV			1.51 V	13	68.7	38.9
5	5398.00	62.6 PK	74.0	-11.4	1.61 V	16	57.1	5.5
6	5398.00	52.2 AV	54.0	-1.8	1.61 V	16	46.7	5.5
7	#10480.00	61.3 PK	74.0	-12.7	1.89 V	200	42.9	18.4
8	#10480.00	48.3 AV	54.0	-5.7	1.89 V	200	29.9	18.4

Remarks:

1. Emission Level(dBuV/m) = Raw Value(dBuV) + Correction Factor(dB/m)
2. Correction Factor(dB/m) = Antenna Factor(dB/m) + Cable Factor(dB) – Pre-Amplifier Factor(dB)
3. The other emission levels were very low against the limit.
4. Margin value = Emission Level – Limit value
5. " * ": Fundamental frequency.
6. " # ": The radiated frequency is out of the restricted band.

CHANNEL	TX Channel 149	DETECTOR FUNCTION	Peak (PK)
FREQUENCY RANGE	1GHz ~ 40GHz		Average (AV)

ANTENNA POLARITY & TEST DISTANCE: HORIZONTAL AT 3 M								
NO.	FREQ. (MHz)	EMISSION LEVEL (dBuV/m)	LIMIT (dBuV/m)	MARGIN (dB)	ANTENNA HEIGHT (m)	TABLE ANGLE (Degree)	RAW VALUE (dBuV)	CORRECTION FACTOR (dB/m)
1	#5585.00	56.5 PK	68.2	-11.7	1.65 H	210	50.4	6.1
2	#5645.60	58.9 PK	68.2	-9.3	1.72 H	208	52.8	6.1
3	*5745.00	105.5 PK			1.72 H	208	65.5	40.0
4	*5745.00	95.4 AV			1.72 H	208	55.4	40.0
5	#5949.60	59.6 PK	68.2	-8.6	1.72 H	208	53.0	6.6
6	11490.00	60.8 PK	74.0	-13.2	1.24 H	122	41.5	19.3
7	11490.00	48.0 AV	54.0	-6.0	1.24 H	122	28.7	19.3

ANTENNA POLARITY & TEST DISTANCE: VERTICAL AT 3 M								
NO.	FREQ. (MHz)	EMISSION LEVEL (dBuV/m)	LIMIT (dBuV/m)	MARGIN (dB)	ANTENNA HEIGHT (m)	TABLE ANGLE (Degree)	RAW VALUE (dBuV)	CORRECTION FACTOR (dB/m)
1	#5585.00	66.9 PK	68.2	-1.3	1.52 V	350	60.8	6.1
2	#5628.80	59.7 PK	68.2	-8.5	1.54 V	347	53.6	6.1
3	*5745.00	120.7 PK			1.54 V	347	80.7	40.0
4	*5745.00	110.8 AV			1.54 V	347	70.8	40.0
5	#5980.80	60.6 PK	68.2	-7.6	1.54 V	347	53.9	6.7
6	11490.00	61.9 PK	74.0	-12.1	1.84 V	321	42.6	19.3
7	11490.00	49.1 AV	54.0	-4.9	1.84 V	321	29.8	19.3

Remarks:

1. Emission Level(dBuV/m) = Raw Value(dBuV) + Correction Factor(dB/m)
2. Correction Factor(dB/m) = Antenna Factor(dB/m) + Cable Factor(dB) – Pre-Amplifier Factor(dB)
3. The other emission levels were very low against the limit.
4. Margin value = Emission Level – Limit value
5. " * ": Fundamental frequency.
6. " # ": The radiated frequency is out of the restricted band.

CHANNEL	TX Channel 157	DETECTOR FUNCTION	Peak (PK)
FREQUENCY RANGE	1GHz ~ 40GHz		Average (AV)

ANTENNA POLARITY & TEST DISTANCE: HORIZONTAL AT 3 M

NO.	FREQ. (MHz)	EMISSION LEVEL (dBuV/m)	LIMIT (dBuV/m)	MARGIN (dB)	ANTENNA HEIGHT (m)	TABLE ANGLE (Degree)	RAW VALUE (dBuV)	CORRECTION FACTOR (dB/m)
1	#5605.60	57.7 PK	68.2	-10.5	1.64 H	210	51.6	6.1
2	#5625.00	56.3 PK	68.2	-11.9	1.60 H	212	50.2	6.1
3	*5785.00	104.6 PK			1.64 H	210	64.5	40.1
4	*5785.00	94.5 AV			1.64 H	210	54.4	40.1
5	#5945.00	56.6 PK	68.2	-11.6	1.55 H	222	50.0	6.6
6	#6000.00	58.4 PK	68.2	-9.8	1.64 H	210	51.7	6.7
7	11570.00	60.2 PK	74.0	-13.8	1.25 H	111	41.0	19.2
8	11570.00	47.4 AV	54.0	-6.6	1.25 H	111	28.2	19.2

ANTENNA POLARITY & TEST DISTANCE: VERTICAL AT 3 M

NO.	FREQ. (MHz)	EMISSION LEVEL (dBuV/m)	LIMIT (dBuV/m)	MARGIN (dB)	ANTENNA HEIGHT (m)	TABLE ANGLE (Degree)	RAW VALUE (dBuV)	CORRECTION FACTOR (dB/m)
1	#5625.00	67.1 PK	68.2	-1.1	1.70 V	305	61.0	6.1
2	#5631.20	64.9 PK	68.2	-3.3	1.62 V	349	58.8	6.1
3	*5785.00	119.9 PK			1.62 V	349	79.8	40.1
4	*5785.00	109.9 AV			1.62 V	349	69.8	40.1
5	#5941.60	63.6 PK	68.2	-4.6	1.62 V	349	57.0	6.6
6	#5945.00	64.1 PK	68.2	-4.1	1.70 V	5	57.5	6.6
7	11570.00	61.8 PK	74.0	-12.2	2.12 V	55	42.6	19.2
8	11570.00	48.8 AV	54.0	-5.2	2.12 V	55	29.6	19.2

Remarks:

1. Emission Level(dBuV/m) = Raw Value(dBuV) + Correction Factor(dB/m)
2. Correction Factor(dB/m) = Antenna Factor(dB/m) + Cable Factor(dB) – Pre-Amplifier Factor(dB)
3. The other emission levels were very low against the limit.
4. Margin value = Emission Level – Limit value
5. " * ": Fundamental frequency.

CHANNEL	TX Channel 165	DETECTOR FUNCTION	Peak (PK)
FREQUENCY RANGE	1GHz ~ 40GHz		Average (AV)

ANTENNA POLARITY & TEST DISTANCE: HORIZONTAL AT 3 M

NO.	FREQ. (MHz)	EMISSION LEVEL (dBuV/m)	LIMIT (dBuV/m)	MARGIN (dB)	ANTENNA HEIGHT (m)	TABLE ANGLE (Degree)	RAW VALUE (dBuV)	CORRECTION FACTOR (dB/m)
1	#5585.00	56.4 PK	68.2	-11.8	1.89 H	55	50.3	6.1
2	#5629.60	57.9 PK	68.2	-10.3	1.67 H	209	51.8	6.1
3	*5825.00	107.5 PK			1.67 H	210	67.4	40.1
4	*5825.00	97.4 AV			1.67 H	210	57.3	40.1
5	#5985.00	56.6 PK	68.2	-11.6	2.01 H	71	49.9	6.7
6	#5987.20	58.9 PK	68.2	-9.3	1.67 H	209	52.2	6.7
7	11650.00	61.2 PK	74.0	-12.8	1.30 H	246	41.9	19.3
8	11650.00	48.4 AV	54.0	-5.6	1.30 H	246	29.1	19.3

ANTENNA POLARITY & TEST DISTANCE: VERTICAL AT 3 M

NO.	FREQ. (MHz)	EMISSION LEVEL (dBuV/m)	LIMIT (dBuV/m)	MARGIN (dB)	ANTENNA HEIGHT (m)	TABLE ANGLE (Degree)	RAW VALUE (dBuV)	CORRECTION FACTOR (dB/m)
1	#5585.00	66.2 PK	68.2	-2.0	1.60 V	347	60.1	6.1
2	#5666.40	65.8 PK	80.4	-14.6	1.52 V	346	59.7	6.1
3	*5825.00	122.5 PK			1.52 V	346	82.4	40.1
4	*5825.00	112.6 AV			1.52 V	346	72.5	40.1
5	#5985.00	66.7 PK	68.2	-1.5	1.62 V	349	60.0	6.7
6	#5987.20	65.6 PK	68.2	-2.6	1.52 V	346	58.9	6.7
7	11650.00	62.6 PK	74.0	-11.4	2.03 V	20	43.3	19.3
8	11650.00	49.6 AV	54.0	-4.4	2.03 V	20	30.3	19.3

Remarks:

1. Emission Level(dBuV/m) = Raw Value(dBuV) + Correction Factor(dB/m)
2. Correction Factor(dB/m) = Antenna Factor(dB/m) + Cable Factor(dB) – Pre-Amplifier Factor(dB)
3. The other emission levels were very low against the limit.
4. Margin value = Emission Level – Limit value
5. " * ": Fundamental frequency.
6. " # ": The radiated frequency is out of the restricted band.

802.11n (HT40)

CHANNEL	TX Channel 38	DETECTOR FUNCTION	Peak (PK) Average (AV)
FREQUENCY RANGE	1GHz ~ 40GHz		

ANTENNA POLARITY & TEST DISTANCE: HORIZONTAL AT 3 M

NO.	FREQ. (MHz)	EMISSION LEVEL (dBuV/m)	LIMIT (dBuV/m)	MARGIN (dB)	ANTENNA HEIGHT (m)	TABLE ANGLE (Degree)	RAW VALUE (dBuV)	CORRECTION FACTOR (dB/m)
1	5030.00	56.5 PK	74.0	-17.5	1.77 H	133	52.2	4.3
2	5030.00	44.6 AV	54.0	-9.4	1.77 H	133	40.3	4.3
3	5150.00	55.4 PK	74.0	-18.6	1.81 H	32	50.6	4.8
4	5150.00	44.3 AV	54.0	-9.7	1.81 H	32	39.5	4.8
5	*5190.00	98.1 PK			2.11 H	141	59.4	38.7
6	*5190.00	87.6 AV			2.11 H	141	48.9	38.7
7	5350.00	58.5 PK	74.0	-15.5	1.20 H	69	53.0	5.5
8	5350.00	46.3 AV	54.0	-7.7	1.20 H	69	40.8	5.5
9	#5622.00	55.0 PK	68.2	-13.2	1.44 H	277	48.9	6.1
10	#10380.00	58.9 PK	74.0	-15.1	1.54 H	136	41.3	17.6
11	#10380.00	46.0 AV	54.0	-8.0	1.54 H	136	28.4	17.6

ANTENNA POLARITY & TEST DISTANCE: VERTICAL AT 3 M

NO.	FREQ. (MHz)	EMISSION LEVEL (dBuV/m)	LIMIT (dBuV/m)	MARGIN (dB)	ANTENNA HEIGHT (m)	TABLE ANGLE (Degree)	RAW VALUE (dBuV)	CORRECTION FACTOR (dB/m)
1	5030.00	60.9 PK	74.0	-13.1	1.56 V	328	56.6	4.3
2	5030.00	49.6 AV	54.0	-4.4	1.56 V	328	45.3	4.3
3	5150.00	72.2 PK	74.0	-1.8	1.94 V	148	67.4	4.8
4	5150.00	51.1 AV	54.0	-2.9	1.94 V	148	46.3	4.8
5	*5190.00	113.3 PK			1.58 V	12	74.6	38.7
6	*5190.00	103.5 AV			1.58 V	12	64.8	38.7
7	5350.00	60.3 PK	74.0	-13.7	1.60 V	4	54.8	5.5
8	5350.00	49.1 AV	54.0	-4.9	1.60 V	4	43.6	5.5
9	#5622.00	62.5 PK	68.2	-5.7	1.44 V	12	56.4	6.1
10	#10380.00	60.3 PK	74.0	-13.7	2.30 V	311	42.7	17.6
11	#10380.00	47.3 AV	54.0	-6.7	2.30 V	311	29.7	17.6

Remarks:

1. Emission Level(dBuV/m) = Raw Value(dBuV) + Correction Factor(dB/m)
2. Correction Factor(dB/m) = Antenna Factor(dB/m) + Cable Factor(dB) – Pre-Amplifier Factor(dB)
3. The other emission levels were very low against the limit.
4. Margin value = Emission Level – Limit value
5. " * ": Fundamental frequency.
6. " # ": The radiated frequency is out of the restricted band.

CHANNEL	TX Channel 46	DETECTOR FUNCTION	Peak (PK)
FREQUENCY RANGE	1GHz ~ 40GHz		Average (AV)

ANTENNA POLARITY & TEST DISTANCE: HORIZONTAL AT 3 M

NO.	FREQ. (MHz)	EMISSION LEVEL (dBuV/m)	LIMIT (dBuV/m)	MARGIN (dB)	ANTENNA HEIGHT (m)	TABLE ANGLE (Degree)	RAW VALUE (dBuV)	CORRECTION FACTOR (dB/m)
1	5070.00	56.3 PK	74.0	-17.7	1.60 H	300	51.7	4.6
2	5070.00	45.3 AV	54.0	-8.7	1.60 H	300	40.7	4.6
3	*5230.00	100.3 PK			1.54 H	198	61.4	38.7
4	*5230.00	90.8 AV			1.54 H	198	51.9	38.7
5	5390.00	56.1 PK	74.0	-17.9	1.80 H	114	50.6	5.5
6	5390.00	45.0 AV	54.0	-9.0	1.80 H	114	39.5	5.5
7	#5666.00	56.1 PK	68.2	-12.1	1.80 H	49	50.0	6.1
8	#10460.00	59.5 PK	74.0	-14.5	2.12 H	21	41.3	18.2
9	#10460.00	46.6 AV	54.0	-7.4	2.12 H	21	28.4	18.2

ANTENNA POLARITY & TEST DISTANCE: VERTICAL AT 3 M

NO.	FREQ. (MHz)	EMISSION LEVEL (dBuV/m)	LIMIT (dBuV/m)	MARGIN (dB)	ANTENNA HEIGHT (m)	TABLE ANGLE (Degree)	RAW VALUE (dBuV)	CORRECTION FACTOR (dB/m)
1	5070.00	61.3 PK	74.0	-12.7	1.56 V	328	56.7	4.6
2	5070.00	52.3 AV	54.0	-1.7	1.56 V	328	47.7	4.6
3	*5230.00	115.5 PK			1.46 V	12	76.6	38.9
4	*5230.00	105.6 AV			1.46 V	12	66.7	38.9
5	5390.00	61.7 PK	74.0	-12.3	1.58 V	14	56.2	5.5
6	5390.00	50.8 AV	54.0	-3.2	1.58 V	14	45.3	5.5
7	#5666.00	60.8 PK	68.2	-7.4	1.63 V	349	54.7	6.1
8	#10460.00	59.8 PK	74.0	-14.2	2.01 V	201	41.6	18.2
9	#10460.00	47.0 AV	54.0	-7.0	2.01 V	201	28.8	18.2

Remarks:

1. Emission Level(dBuV/m) = Raw Value(dBuV) + Correction Factor(dB/m)
2. Correction Factor(dB/m) = Antenna Factor(dB/m) + Cable Factor(dB) – Pre-Amplifier Factor(dB)
3. The other emission levels were very low against the limit.
4. Margin value = Emission Level – Limit value
5. " * ": Fundamental frequency.
6. " # ": The radiated frequency is out of the restricted band.

CHANNEL	TX Channel 151	DETECTOR FUNCTION	Peak (PK)
FREQUENCY RANGE	1GHz ~ 40GHz		Average (AV)

ANTENNA POLARITY & TEST DISTANCE: HORIZONTAL AT 3 M								
NO.	FREQ. (MHz)	EMISSION LEVEL (dBuV/m)	LIMIT (dBuV/m)	MARGIN (dB)	ANTENNA HEIGHT (m)	TABLE ANGLE (Degree)	RAW VALUE (dBuV)	CORRECTION FACTOR (dB/m)
1	#5560.00	56.6 PK	68.2	-11.6	1.76 H	11	50.7	5.9
2	#5644.80	58.0 PK	68.2	-10.2	1.78 H	124	51.9	6.1
3	#5650.00	58.4 PK	68.2	-9.8	1.77 H	11	52.3	6.1
4	*5755.00	97.7 PK			1.78 H	124	57.7	40.0
5	*5755.00	87.9 AV			1.78 H	124	47.9	40.0
6	#5951.20	59.1 PK	68.2	-9.1	1.78 H	124	52.5	6.6
7	11510.00	60.2 PK	74.0	-13.8	1.65 H	275	40.9	19.3
8	11510.00	47.2 AV	54.0	-6.8	1.65 H	275	27.9	19.3

ANTENNA POLARITY & TEST DISTANCE: VERTICAL AT 3 M								
NO.	FREQ. (MHz)	EMISSION LEVEL (dBuV/m)	LIMIT (dBuV/m)	MARGIN (dB)	ANTENNA HEIGHT (m)	TABLE ANGLE (Degree)	RAW VALUE (dBuV)	CORRECTION FACTOR (dB/m)
1	#5560.00	65.2 PK	68.2	-3.0	1.55 V	318	59.3	5.9
2	#5612.80	63.3 PK	68.2	-4.9	1.50 V	345	57.2	6.1
3	#5650.00	66.5 PK	68.2	-1.7	1.64 V	10	60.4	6.1
4	*5755.00	117.8 PK			1.50 V	345	77.8	40.0
5	*5755.00	108.1 AV			1.50 V	345	68.1	40.0
6	#5928.80	61.5 PK	68.2	-6.7	1.50 V	345	54.9	6.6
7	11510.00	60.8 PK	74.0	-13.2	2.05 V	310	41.5	19.3
8	11510.00	47.8 AV	54.0	-6.2	2.05 V	310	28.5	19.3

Remarks:

1. Emission Level(dBuV/m) = Raw Value(dBuV) + Correction Factor(dB/m)
2. Correction Factor(dB/m) = Antenna Factor(dB/m) + Cable Factor(dB) – Pre-Amplifier Factor(dB)
3. The other emission levels were very low against the limit.
4. Margin value = Emission Level – Limit value
5. " * ": Fundamental frequency.
6. " # ": The radiated frequency is out of the restricted band.

CHANNEL	TX Channel 159	DETECTOR FUNCTION	Peak (PK)
FREQUENCY RANGE	1GHz ~ 40GHz		Average (AV)

ANTENNA POLARITY & TEST DISTANCE: HORIZONTAL AT 3 M								
NO.	FREQ. (MHz)	EMISSION LEVEL (dBuV/m)	LIMIT (dBuV/m)	MARGIN (dB)	ANTENNA HEIGHT (m)	TABLE ANGLE (Degree)	RAW VALUE (dBuV)	CORRECTION FACTOR (dB/m)
1	#5640.00	61.2 PK	68.2	-7.0	1.80 H	301	55.1	6.1
2	#5640.00	57.7 PK	68.2	-10.5	1.75 H	124	51.6	6.1
3	*5795.00	100.9 PK			1.75 H	124	60.8	40.1
4	*5795.00	91.2 AV			1.75 H	124	51.1	40.1
5	#5955.00	57.0 PK	68.2	-11.2	1.70 H	222	50.4	6.6
6	#5962.40	59.0 PK	68.2	-9.2	1.75 H	124	52.3	6.7
7	11590.00	61.3 PK	74.0	-12.7	1.30 H	27	42.1	19.2
8	11590.00	48.4 AV	54.0	-5.6	1.30 H	27	29.2	19.2

ANTENNA POLARITY & TEST DISTANCE: VERTICAL AT 3 M								
NO.	FREQ. (MHz)	EMISSION LEVEL (dBuV/m)	LIMIT (dBuV/m)	MARGIN (dB)	ANTENNA HEIGHT (m)	TABLE ANGLE (Degree)	RAW VALUE (dBuV)	CORRECTION FACTOR (dB/m)
1	#5640.00	66.4 PK	68.2	-1.8	1.55 V	317	60.3	6.1
2	#5648.00	64.0 PK	68.2	-4.2	1.61 V	350	57.9	6.1
3	*5795.00	120.1 PK			1.61 V	350	80.0	40.1
4	*5795.00	110.0 AV			1.61 V	350	69.9	40.1
5	#5954.40	63.1 PK	68.2	-5.1	1.61 V	350	56.5	6.6
6	#5955.00	63.5 PK	68.2	-4.7	1.63 V	6	56.9	6.6
7	11590.00	62.3 PK	74.0	-11.7	2.22 V	270	43.1	19.2
8	11590.00	49.4 AV	54.0	-4.6	2.22 V	270	30.2	19.2

Remarks:

1. Emission Level(dBuV/m) = Raw Value(dBuV) + Correction Factor(dB/m)
2. Correction Factor(dB/m) = Antenna Factor(dB/m) + Cable Factor(dB) – Pre-Amplifier Factor(dB)
3. The other emission levels were very low against the limit.
4. Margin value = Emission Level – Limit value
5. " * ": Fundamental frequency.
6. " # ": The radiated frequency is out of the restricted band.

802.11ac (VHT80)

CHANNEL	TX Channel 42	DETECTOR FUNCTION	Peak (PK)
FREQUENCY RANGE	1GHz ~ 40GHz		Average (AV)

ANTENNA POLARITY & TEST DISTANCE: HORIZONTAL AT 3 M

NO.	FREQ. (MHz)	EMISSION LEVEL (dBuV/m)	LIMIT (dBuV/m)	MARGIN (dB)	ANTENNA HEIGHT (m)	TABLE ANGLE (Degree)	RAW VALUE (dBuV)	CORRECTION FACTOR (dB/m)
1	5150.00	55.3 PK	74.0	-18.7	1.50 H	144	50.5	4.8
2	5150.00	44.1 AV	54.0	-9.9	1.50 H	144	39.3	4.8
3	*5210.00	92.4 PK			1.52 H	196	53.7	38.7
4	*5210.00	83.4 AV			1.52 H	196	44.7	38.7
5	5350.00	56.4 PK	74.0	-17.6	1.48 H	117	50.9	5.5
6	5350.00	45.1 AV	54.0	-8.9	1.48 H	117	39.6	5.5
7	#5788.00	58.8 PK	68.2	-9.4	1.54 H	222	52.4	6.4
8	#10420.00	58.9 PK	74.0	-15.1	1.33 H	345	41.1	17.8
9	#10420.00	46.1 AV	54.0	-7.9	1.33 H	345	28.3	17.8

ANTENNA POLARITY & TEST DISTANCE: VERTICAL AT 3 M

NO.	FREQ. (MHz)	EMISSION LEVEL (dBuV/m)	LIMIT (dBuV/m)	MARGIN (dB)	ANTENNA HEIGHT (m)	TABLE ANGLE (Degree)	RAW VALUE (dBuV)	CORRECTION FACTOR (dB/m)
1	5150.00	69.1 PK	74.0	-4.9	1.67 V	7	64.3	4.8
2	5150.00	52.8 AV	54.0	-1.2	1.67 V	7	48.0	4.8
3	*5210.00	108.1 PK			1.61 V	325	69.4	38.7
4	*5210.00	99.2 AV			1.61 V	325	60.5	38.7
5	5350.00	57.2 PK	74.0	-16.8	1.60 V	310	51.7	5.5
6	5350.00	45.7 AV	54.0	-8.3	1.60 V	310	40.2	5.5
7	#5788.00	61.5 PK	68.2	-6.7	1.64 V	317	55.1	6.4
8	#10420.00	59.7 PK	74.0	-14.3	1.89 V	291	41.9	17.8
9	#10420.00	46.8 AV	54.0	-7.2	1.89 V	291	29.0	17.8

Remarks:

1. Emission Level(dBuV/m) = Raw Value(dBuV) + Correction Factor(dB/m)
2. Correction Factor(dB/m) = Antenna Factor(dB/m) + Cable Factor(dB) – Pre-Amplifier Factor(dB)
3. The other emission levels were very low against the limit.
4. Margin value = Emission Level – Limit value
5. " * ": Fundamental frequency.
6. " # ": The radiated frequency is out of the restricted band.

CHANNEL	TX Channel 155	DETECTOR FUNCTION	Peak (PK)
FREQUENCY RANGE	1GHz ~ 40GHz		Average (AV)

ANTENNA POLARITY & TEST DISTANCE: HORIZONTAL AT 3 M								
NO.	FREQ. (MHz)	EMISSION LEVEL (dBuV/m)	LIMIT (dBuV/m)	MARGIN (dB)	ANTENNA HEIGHT (m)	TABLE ANGLE (Degree)	RAW VALUE (dBuV)	CORRECTION FACTOR (dB/m)
1	5133.00	55.3 PK	74.0	-18.7	1.30 H	19	50.5	4.8
2	5133.00	45.0 AV	54.0	-9.0	1.30 H	19	40.2	4.8
3	#5605.60	58.4 PK	68.2	-9.8	1.80 H	123	52.3	6.1
4	*5775.00	88.9 PK			1.80 H	123	48.9	40.0
5	*5775.00	79.4 AV			1.80 H	123	39.4	40.0
6	#5963.20	59.3 PK	68.2	-8.9	1.80 H	123	52.6	6.7
7	11550.00	59.7 PK	74.0	-14.3	1.11 H	220	40.5	19.2
8	11550.00	46.6 AV	54.0	-7.4	1.11 H	220	27.4	19.2

ANTENNA POLARITY & TEST DISTANCE: VERTICAL AT 3 M								
NO.	FREQ. (MHz)	EMISSION LEVEL (dBuV/m)	LIMIT (dBuV/m)	MARGIN (dB)	ANTENNA HEIGHT (m)	TABLE ANGLE (Degree)	RAW VALUE (dBuV)	CORRECTION FACTOR (dB/m)
1	5133.00	59.5 PK	74.0	-14.5	1.52 V	11	54.7	4.8
2	5133.00	53.0 AV	54.0	-1.0	1.52 V	11	48.2	4.8
3	#5608.80	59.2 PK	68.2	-9.0	1.69 V	325	53.1	6.1
4	*5775.00	105.1 PK			1.69 V	325	65.1	40.0
5	*5775.00	96.3 AV			1.69 V	325	56.3	40.0
6	#5992.80	58.5 PK	68.2	-9.7	1.69 V	325	51.8	6.7
7	11550.00	60.7 PK	74.0	-13.3	1.83 V	322	41.5	19.2
8	11550.00	47.7 AV	54.0	-6.3	1.83 V	322	28.5	19.2

Remarks:

1. Emission Level(dBuV/m) = Raw Value(dBuV) + Correction Factor(dB/m)
2. Correction Factor(dB/m) = Antenna Factor(dB/m) + Cable Factor(dB) – Pre-Amplifier Factor(dB)
3. The other emission levels were very low against the limit.
4. Margin value = Emission Level – Limit value
5. " * ": Fundamental frequency.
6. " # ": The radiated frequency is out of the restricted band.

Below 1GHz Worst-Case Data:

802.11a

CHANNEL	TX Channel 36	DETECTOR FUNCTION	Quasi-Peak (QP)
FREQUENCY RANGE	9kHz ~ 1GHz		

ANTENNA POLARITY & TEST DISTANCE: HORIZONTAL AT 3 M								
NO.	FREQ. (MHz)	EMISSION LEVEL (dBuV/m)	LIMIT (dBuV/m)	MARGIN (dB)	ANTENNA HEIGHT (m)	TABLE ANGLE (Degree)	RAW VALUE (dBuV)	CORRECTION FACTOR (dB/m)
1	57.12	29.8 QP	40.0	-10.2	1.99 H	103	44.4	-14.6
2	99.89	23.1 QP	43.5	-20.4	1.99 H	244	41.9	-18.8
3	140.72	24.2 QP	43.5	-19.3	1.99 H	276	38.7	-14.5
4	284.60	22.9 QP	46.0	-23.1	1.00 H	214	35.3	-12.4
5	714.29	29.6 QP	46.0	-16.4	1.50 H	13	32.9	-3.3
6	799.84	33.5 QP	46.0	-12.5	1.00 H	127	35.0	-1.5
ANTENNA POLARITY & TEST DISTANCE: VERTICAL AT 3 M								
NO.	FREQ. (MHz)	EMISSION LEVEL (dBuV/m)	LIMIT (dBuV/m)	MARGIN (dB)	ANTENNA HEIGHT (m)	TABLE ANGLE (Degree)	RAW VALUE (dBuV)	CORRECTION FACTOR (dB/m)
1	43.51	37.9 QP	40.0	-2.1	1.00 V	14	52.7	-14.8
2	62.95	35.1 QP	40.0	-4.9	1.00 V	349	50.2	-15.1
3	144.61	27.7 QP	43.5	-15.8	1.00 V	305	41.9	-14.2
4	245.72	24.5 QP	46.0	-21.5	1.51 V	197	38.6	-14.1
5	393.48	23.6 QP	46.0	-22.4	1.00 V	206	33.7	-10.1
6	799.84	31.9 QP	46.0	-14.1	1.51 V	121	33.4	-1.5

Remarks:

1. Emission Level(dBuV/m) = Raw Value(dBuV) + Correction Factor(dB/m)
2. Correction Factor(dB/m) = Antenna Factor(dB/m) + Cable Factor(dB) – Pre-Amplifier Factor(dB)
3. The other emission levels were very low against the limit.
4. Margin value = Emission Level – Limit value

4.2 Conducted Emission Measurement

4.2.1 Limits of Conducted Emission Measurement

Frequency (MHz)	Conducted Limit (dBuV)	
	Quasi-peak	Average
0.15 - 0.5	66 - 56	56 - 46
0.50 - 5.0	56	46
5.0 - 30.0	60	50

- Note:** 1. The lower limit shall apply at the transition frequencies.
 2. The limit decreases in line with the logarithm of the frequency in the range of 0.15 to 0.50MHz.

4.2.2 Test Instruments

Description & Manufacturer	Model No.	Serial No.	Cal. Date	Cal. Due
Test Receiver ROHDE & SCHWARZ	ESCS30	100289	Dec. 23, 2015	Dec. 22, 2016
RF signal cable (with 10dB PAD) Woken	5D-FB	Cable-cond2-01	Dec. 26, 2015	Dec. 25, 2016
LISN ROHDE & SCHWARZ (EUT)	ESH2-Z5	100100	Jan. 11, 2016	Jan. 10, 2017
LISN ROHDE & SCHWARZ (Peripheral)	ESH3-Z5	100312	Jul. 26, 2016	Jul. 25, 2017
Software ADT	BV ADT_Cond_ V7.3.7.3	NA	NA	NA

- Note:** 1. The calibration interval of the above test instruments is 12 months and the calibrations are traceable to NML/ROC and NIST/USA.
 2. The test was performed in HwaYa Shielded Room 2.
 3. The VCCI Site Registration No. is C-2047.

4.2.3 Test Procedures

- The EUT was placed 0.4 meters from the conducting wall of the shielded room with EUT being connected to the power mains through a line impedance stabilization network (LISN). Other support units were connected to the power mains through another LISN. The two LISNs provide 50 ohm/ 50uH of coupling impedance for the measuring instrument.
- Both lines of the power mains connected to the EUT were checked for maximum conducted interference.
- The frequency range from 150kHz to 30MHz was searched. Emission levels under (Limit - 20dB) was not recorded.

NOTE: The resolution bandwidth and video bandwidth of test receiver is 9kHz for quasi-peak detection (QP) and average detection (AV) at frequency 0.15MHz-30MHz.

4.2.4 Deviation from Test Standard

No deviation.

4.2.5 Test Setup

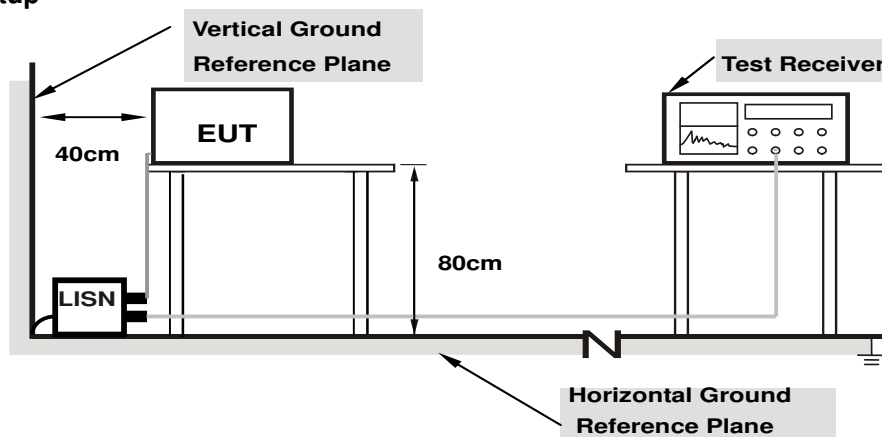

Note: 1.Support units were connected to second LISN.

For the actual test configuration, please refer to the attached file (Test Setup Photo).

4.2.6 EUT Operating Conditions

Same as 4.1.6.

4.2.7 Test Results

Phase	Line (L)	Detector Function	Quasi-Peak (QP) / Average (AV)
-------	----------	-------------------	--------------------------------

No	Freq. [MHz]	Corr. Factor (dB)	Reading Value		Emission Level		Limit		Margin	
			[dB (uV)]		[dB (uV)]		[dB (uV)]		(dB)	
			Q.P.	AV.	Q.P.	AV.	Q.P.	AV.	Q.P.	AV.
1	0.15000	10.18	38.73	25.22	48.91	35.40	66.00	56.00	-17.09	-20.60
2	0.18906	10.20	31.62	18.38	41.82	28.58	64.08	54.08	-22.26	-25.50
3	0.41953	10.24	23.68	18.37	33.92	28.61	57.46	47.46	-23.54	-18.85
4	0.52109	10.25	34.78	29.95	45.03	40.20	56.00	46.00	-10.97	-5.80
5	3.76563	10.41	24.47	19.71	34.88	30.12	56.00	46.00	-21.12	-15.88
6	11.03125	10.54	29.82	25.16	40.36	35.70	60.00	50.00	-19.64	-14.30

Remarks:

1. Q.P. and AV. are abbreviations of quasi-peak and average individually.
2. The emission levels of other frequencies were very low against the limit.
3. Margin value = Emission level - Limit value
4. Correction factor = Insertion loss + Cable loss
5. Emission Level = Correction Factor + Reading Value.

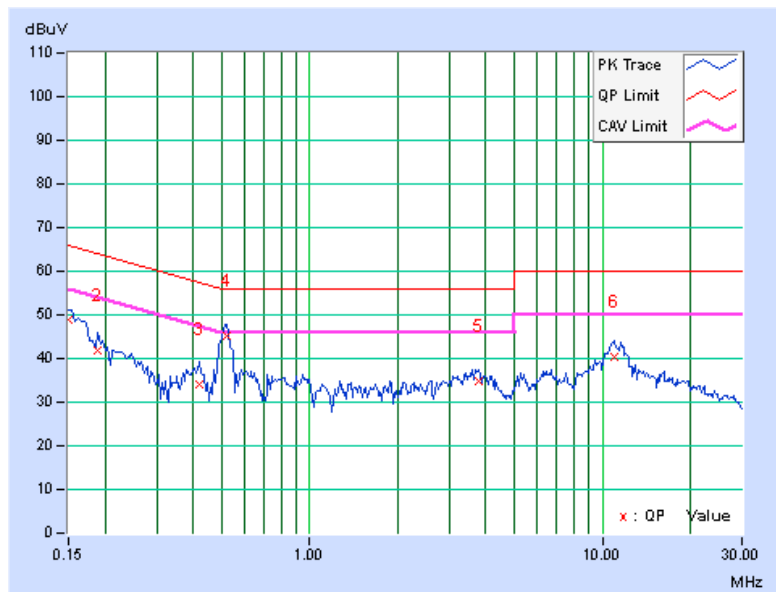

Phase	Neutral (N)	Detector Function	Quasi-Peak (QP) / Average (AV)
-------	-------------	-------------------	--------------------------------

No	Freq. [MHz]	Corr. Factor (dB)	Reading Value		Emission Level		Limit		Margin	
			[dB (uV)]		[dB (uV)]		[dB (uV)]		(dB)	
			Q.P.	AV.	Q.P.	AV.	Q.P.	AV.	Q.P.	AV.
1	0.16562	10.19	35.11	22.38	45.30	32.57	65.18	55.18	-19.88	-22.61
2	0.22812	10.21	26.40	15.08	36.61	25.29	62.52	52.52	-25.91	-27.23
3	0.52500	10.30	34.78	30.63	45.08	40.93	56.00	46.00	-10.92	-5.07
4	0.60313	10.30	21.43	15.63	31.73	25.93	56.00	46.00	-24.27	-20.07
5	3.44922	10.51	19.95	14.05	30.46	24.56	56.00	46.00	-25.54	-21.44
6	10.76172	10.63	27.48	22.41	38.11	33.04	60.00	50.00	-21.89	-16.96

Remarks:

1. Q.P. and AV. are abbreviations of quasi-peak and average individually.
2. The emission levels of other frequencies were very low against the limit.
3. Margin value = Emission level - Limit value
4. Correction factor = Insertion loss + Cable loss
5. Emission Level = Correction Factor + Reading Value.

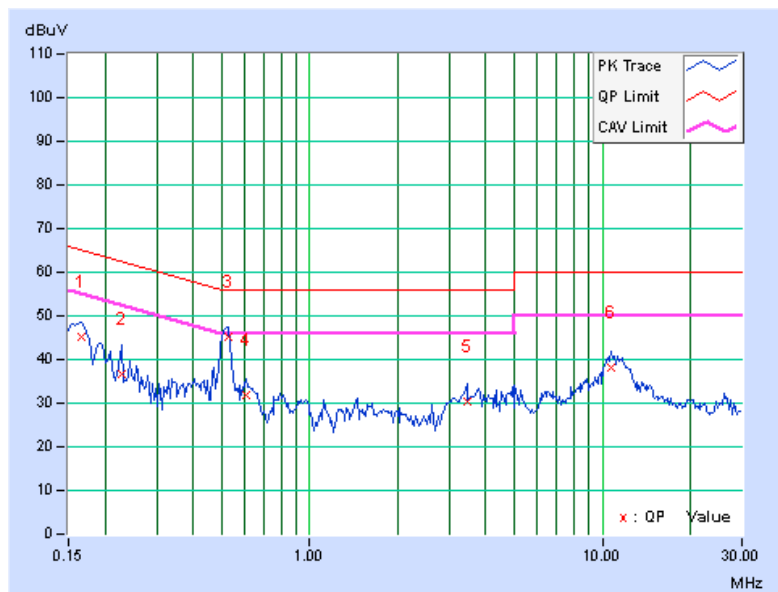

4.3 Transmit Power Measurement

4.3.1 Limits of Transmit Power Measurement

Operation Band	EUT Category		LIMIT
U-NII-1	√	Outdoor Access Point	1 Watt (30 dBm) (Max. e.i.r.p ≤ 125mW(21 dBm) at any elevation angle above 30 degrees as measured from the horizon)
		Fixed point-to-point Access Point	1 Watt (30 dBm)
		Indoor Access Point	1 Watt (30 dBm)
		Mobile and Portable client device	250mW (24 dBm)
U-NII-2A	---		250mW (24 dBm) or 11 dBm+10 log B*
U-NII-2C	---		250mW (24 dBm) or 11 dBm+10 log B*
U-NII-3	√		1 Watt (30 dBm)

*B is the 26 dB emission bandwidth in megahertz

4.3.2 Test Setup

For Power Output Measurement
802.11a, 802.11n (HT20), 802.11n (HT40)

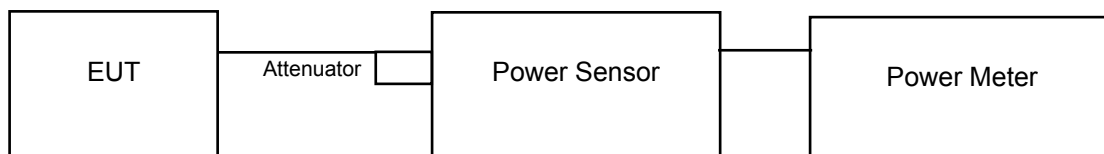

802.11ac (VHT80)

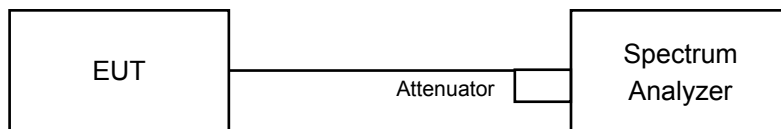

4.3.3 Test Instruments

Refer to section 4.1.2 to get information of above instrument.

4.3.4 Test Procedure

For Average Power Measurement

For 802.11a, 802.11n (HT20), 802.11n (HT40)

Method PM is used to perform output power measurement, trigger and gating function of wide band power meter is enabled to measure max output power of TX on burst. Duty factor is not added to measured value.

For 802.11ac (VHT80)

- a. Set span to encompass the entire 26 dB EBW (or, alternatively, the entire 99% occupied bandwidth) of the signal.
- b. Set sweep trigger to "free run".
- c. Set RBW = 1 MHz.
- d. Set VBW \geq 3 MHz
- e. Number of points in sweep \geq 2 Span / RBW.
- f. Sweep time \leq (number of points in sweep) * T
- g. Using emission bandwidth to determine the frequency span for integration the channel bandwidth.
- h. Detector = RMS.
- i. Trace mode = max hold.
- j. Allow max hold to run for at least 60 seconds, or longer as needed to allow the trace to stabilize.
- k. Compute power by integrating the spectrum across the EBW (or, alternatively, the entire 99% occupied bandwidth) of the signal using the instrument's band power measurement function with band limits set equal to the EBW (or occupied bandwidth) band edges. If the instrument does not have a band power function, sum the spectrum levels (in power units) at 1 MHz intervals extending across the EBW (or, alternatively, the entire 99% occupied bandwidth) of the spectrum.

4.3.5 Deviation from Test Standard

No deviation.

4.3.6 EUT Operating Conditions

The software provided by client to enable the EUT under transmission condition continuously at lowest, middle and highest channel frequencies individually.

4.3.7 Test Result

Power Output:

For U-NII-1 Band

802.11a

Chan.	Freq. (MHz)	Maximum Conducted Power (dBm)			Total Power (mW)	Total Power (dBm)	Power Limit (dBm)	Gain (dBi)	EIRP (dBm)	EIRP limit (dBm)	Pass / Fail
		Chain 0	Chain 1	Chain 2							
36	5180	16.80	16.64	16.48	138.458	21.41	30.00	-3.88	17.53	21.00	Pass
40	5200	15.78	15.03	14.91	100.660	20.03	30.00	-3.88	16.15	21.00	Pass
48	5240	16.46	15.64	15.33	115.022	20.61	30.00	-3.88	16.73	21.00	Pass

Note:

Gain = -3.88dBi (above 30 degrees from the horizon),

EIRP = conducted power +(-3.88dBi) + array gain = (0 dB (i.e., no array gain) for NANT ≤ 4).

802.11n (HT20)

Chan.	Freq. (MHz)	Maximum Conducted Power (dBm)			Total Power (mW)	Total Power (dBm)	Power Limit (dBm)	Gain (dBi)	EIRP (dBm)	EIRP limit (dBm)	Pass / Fail
		Chain 0	Chain 1	Chain 2							
36	5180	16.90	16.61	16.38	138.243	21.41	30.00	-3.88	17.53	21.00	Pass
40	5200	16.11	15.44	15.31	109.790	20.41	30.00	-3.88	16.53	21.00	Pass
48	5240	16.34	15.63	15.41	114.366	20.58	30.00	-3.88	16.70	21.00	Pass

Note:

Gain = -3.88dBi (above 30 degrees from the horizon),

EIRP = conducted power +(-3.88dBi) + array gain = (0 dB (i.e., no array gain) for NANT ≤ 4).

802.11n (HT40)

Chan.	Freq. (MHz)	Maximum Conducted Power (dBm)			Total Power (mW)	Total Power (dBm)	Power Limit (dBm)	Gain (dBi)	EIRP (dBm)	EIRP limit (dBm)	Pass / Fail
		Chain 0	Chain 1	Chain 2							
38	5190	15.56	14.98	14.70	96.964	19.87	30.00	-3.88	15.99	21.00	Pass
46	5230	17.71	17.06	17.04	160.418	22.05	30.00	-3.88	18.17	21.00	Pass

Note:

Gain = -3.88dBi (above 30 degrees from the horizon),

EIRP = conducted power +(-3.88dBi) + array gain = (0 dB (i.e., no array gain) for NANT ≤ 4).

802.11ac (VHT80)

Chan.	Freq. (MHz)	Maximum Conducted Power (dBm)			Total Power (mW)	Total Power (dBm)	Power Limit (dBm)	Gain (dBi)	EIRP (dBm)	EIRP limit (dBm)	Pass / Fail
		Chain 0	Chain 1	Chain 2							
42	5210	14.50	14.36	14.39	82.953	19.19	30.00	-3.88	15.31	21.00	Pass

Note:

Gain = -3.88dBi (above 30 degrees from the horizon),

EIRP = conducted power +(-3.88dBi) + array gain = (0 dB (i.e., no array gain) for NANT ≤ 4).

For U-NII-3 Band

802.11a

Chan.	Freq. (MHz)	Maximum Conducted Power (dBm)			Total Power (mW)	Total Power (dBm)	Power Limit (dBm)	Pass / Fail
		Chain 0	Chain 1	Chain 2				
149	5745	19.47	19.19	18.70	245.628	23.90	30.00	Pass
157	5785	19.35	18.83	18.37	231.190	23.64	30.00	Pass
165	5825	20.88	20.92	20.30	353.209	25.48	30.00	Pass

802.11n (HT20)

Chan.	Freq. (MHz)	Maximum Conducted Power (dBm)			Total Power (mW)	Total Power (dBm)	Power Limit (dBm)	Pass / Fail
		Chain 0	Chain 1	Chain 2				
149	5745	20.32	20.14	19.61	302.334	24.80	30.00	Pass
157	5785	19.35	18.76	18.36	229.810	23.61	30.00	Pass
165	5825	21.62	21.96	21.43	441.242	26.45	30.00	Pass

802.11n (HT40)

Chan.	Freq. (MHz)	Maximum Conducted Power (dBm)			Total Power (mW)	Total Power (dBm)	Power Limit (dBm)	Pass / Fail
		Chain 0	Chain 1	Chain 2				
151	5755	20.32	19.98	19.49	296.108	24.71	30.00	Pass
159	5795	21.38	21.44	20.82	397.501	25.99	30.00	Pass

802.11ac (VHT80)

Chan.	Freq. (MHz)	Maximum Conducted Power (dBm)			Total Power (mW)	Total Power (dBm)	Power Limit (dBm)	Pass / Fail
		Chain 0	Chain 1	Chain 2				
155	5775	11.51	11.51	11.21	41.529	16.18	30.00	Pass

4.4 Occupied Bandwidth Measurement

4.4.1 Test Setup

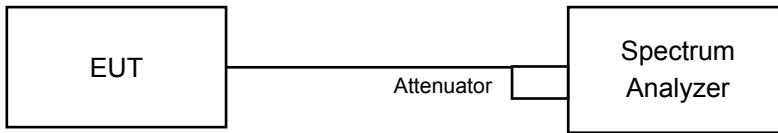

4.4.2 Test Instruments

Refer to section 4.1.2 to get information of above instrument.

4.4.3 Test Procedure

The transmitter output was connected to the spectrum analyzer through an attenuator. The bandwidth of the fundamental frequency was measured by spectrum analyzer with resolution bandwidth in the range of 1% to 5% of the anticipated emission bandwidth, and a video bandwidth at least 3x the resolution bandwidth and set the detector to Sampling. The width of a frequency band such that, below the lower and above the upper frequency limits, the mean powers emitted are each equal to a specified percentage 0.5 %of the total mean power of a given emission.

4.4.4 Test Result

802.11a

Chan.	Freq. (MHz)	Occupied Bandwidth (MHz)		
		Chain 0	Chain 1	Chain 2
36	5180	16.92	16.80	16.80
40	5200	16.92	16.80	16.80
48	5240	16.92	16.80	16.80
149	5745	16.95	16.86	16.78
157	5785	17.04	16.80	16.92
165	5825	17.16	17.04	16.92

802.11n (HT20)

Chan.	Freq. (MHz)	Occupied Bandwidth (MHz)		
		Chain 0	Chain 1	Chain 2
36	5180	17.88	17.76	17.76
40	5200	17.88	17.76	17.88
48	5240	17.88	17.76	17.76
149	5745	18.12	17.88	17.88
157	5785	17.88	17.88	17.88
165	5825	18.36	18.48	18.00

802.11n (HT40)

Chan.	Freq. (MHz)	Occupied Bandwidth (MHz)		
		Chain 0	Chain 1	Chain 2
38	5190	36.72	36.60	36.60
46	5230	36.60	36.72	36.84
151	5755	36.96	36.96	36.84
159	5795	37.20	37.20	36.96

802.11ac (VHT80)

Chan.	Freq. (MHz)	Occupied Bandwidth (MHz)		
		Chain 0	Chain 1	Chain 2
42	5210	75.88	75.88	75.88
155	5775	75.88	76.16	76.16

Spectrum Plot of Worst Value

802.11a

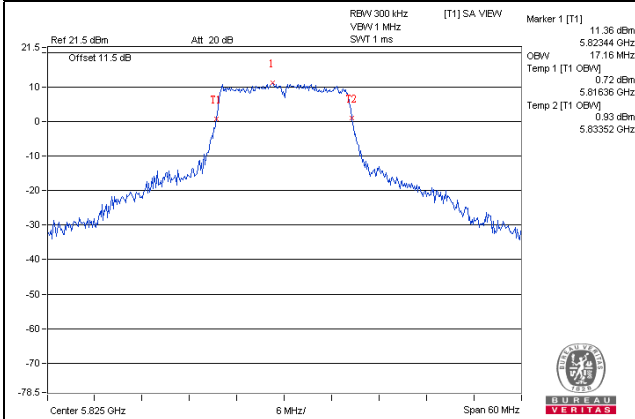

802.11n (HT20)

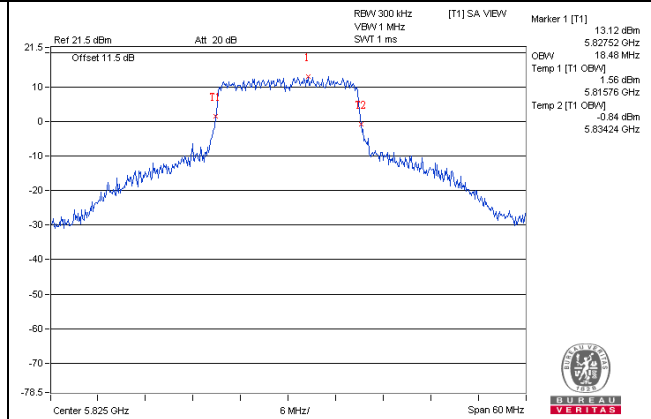

802.11n (HT40)

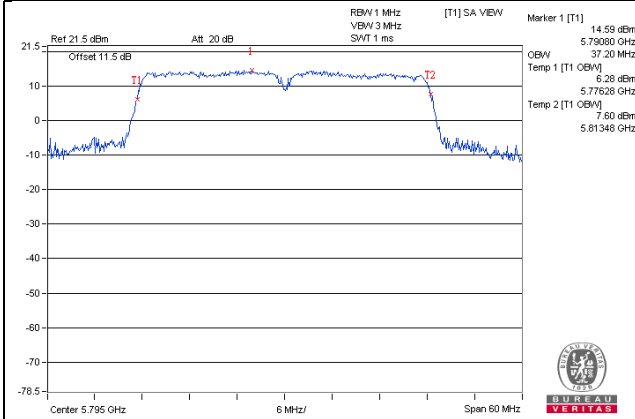

802.11ac (VHT80)

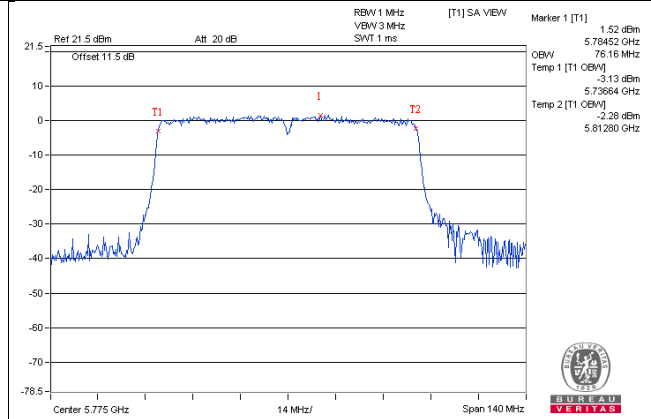

4.5 Peak Power Spectral Density Measurement

4.5.1 Limits of Peak Power Spectral Density Measurement

Operation Band	EUT Category		LIMIT
U-NII-1	√	Outdoor Access Point	17dBm/ MHz
		Fixed point-to-point Access Point	
		Indoor Access Point	11dBm/ MHz
		Mobile and Portable client device	
U-NII-2A	---		11dBm/ MHz
U-NII-2C	---		11dBm/ MHz
U-NII-3	√		30dBm/ 500kHz

4.5.2 Test Setup

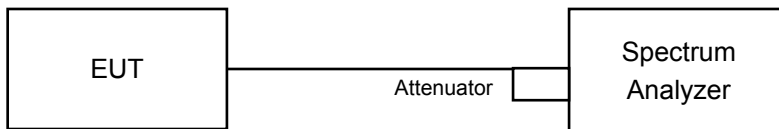

4.5.3 Test Instruments

Refer to section 4.1.2 to get information of above instrument.

4.5.4 Test Procedures

For U-NII-1 band:

Duty cycle >98%, using method SA-1

- Set span to encompass the entire emission bandwidth (EBW) of the signal.
- Set RBW = 1 MHz, Set VBW ≥ 3 MHz, Detector = RMS
- Sweep time = auto, trigger set to “free run”.
- Trace average at least 100 traces in power averaging mode.
- Record the max value

Duty cycle <98%, using method SA-2

- Set span to encompass the entire emission bandwidth (EBW) of the signal.
- Set RBW = 1 MHz, Set VBW ≥ 3 MHz, Detector = RMS
- Sweep time = auto, trigger set to “free run”.
- Trace average at least 100 traces in power averaging mode.
- Record the max value and add 10 log (1/duty cycle)

For U-NII-3 band:

Duty cycle >98%

- a. Set span to encompass the entire emission bandwidth (EBW) of the signal.
- b. Set RBW = 300 kHz, Set VBW \geq 1 MHz, Detector = RMS
- c. Use the peak marker function to determine the maximum power level in any 300 kHz band segment within the fundamental EBW.
- d. Scale the observed power level to an equivalent value in 500 kHz by adjusting (reducing) the measured power by a bandwidth correction factor (BWCF) where $BWCF = 10\log(500 \text{ kHz}/300\text{kHz})$
- e. Sweep time = auto, trigger set to "free run".
- f. Trace average at least 100 traces in power averaging mode.
- g. Record the max value

Duty cycle <98%

- a. Set span to encompass the entire emission bandwidth (EBW) of the signal.
- b. Set RBW = 300 kHz, Set VBW \geq 1 MHz, Detector = RMS
- c. Use the peak marker function to determine the maximum power level in any 300 kHz band segment within the fundamental EBW.
- d. Scale the observed power level to an equivalent value in 500 kHz by adjusting (reducing) the measured power by a bandwidth correction factor (BWCF) where $BWCF = 10\log(500 \text{ kHz}/300\text{kHz})$
- e. Sweep time = auto, trigger set to "free run".
- f. Trace average at least 100 traces in power averaging mode.
- g. Record the max value and add $10 \log (1/\text{duty cycle})$

4.5.5 Deviation from Test Standard

No deviation.

4.5.6 EUT Operating Conditions

Same as Item 4.3.6.

4.5.7 Test Results

For U-NII-1 Band

802.11a

Chan.	Freq. (MHz)	PSD (dBm/MHz)			Total PSD (dBm/MHz)	Max. Limit (dBm/MHz)	Pass / Fail
		Chain 0	Chain 1	Chain 2			
36	5180	3.91	3.46	4.03	8.58	12.23	Pass
40	5200	2.78	1.75	2.14	7.02	12.23	Pass
48	5240	2.83	2.78	1.94	7.31	12.23	Pass

Note:

- Method 1 of power density measurement of KDB 662911 is using for calculating total power density. Total power density is summing entire spectra across corresponding frequency bins on the various outputs by computer.
- Directional gain = $6\text{dBi} + 10\log(3) = 10.77\text{dBi} > 6\text{dBi}$, so the power density limit shall be reduced to $17 - (10.77 - 6) = 12.23\text{dBm}$.

802.11n (HT20)

Chan.	Freq. (MHz)	PSD (dBm/MHz)			Total PSD (dBm/MHz)	Max. Limit (dBm/MHz)	Pass / Fail
		Chain 0	Chain 1	Chain 2			
36	5180	3.91	2.64	3.39	8.12	12.23	Pass
40	5200	3.11	1.69	2.14	7.13	12.23	Pass
48	5240	2.74	2.19	1.62	6.98	12.23	Pass

Note:

- Method 1 of power density measurement of KDB 662911 is using for calculating total power density. Total power density is summing entire spectra across corresponding frequency bins on the various outputs by computer.
- Directional gain = $6\text{dBi} + 10\log(3) = 10.77\text{dBi} > 6\text{dBi}$, so the power density limit shall be reduced to $17 - (10.77 - 6) = 12.23\text{dBm}$.

802.11n (HT40)

Chan.	Freq. (MHz)	PSD w/o Duty Factor (dBm)			Duty Factor (dB)	Total PSD with Duty Factor (dBm)	Max. Limit (dBm)	Pass / Fail
		Chain 0	Chain 1	Chain 2				
38	5190	-0.55	-1.83	-1.48	0.14	3.66	12.23	Pass
46	5230	1.10	0.72	0.29	0.14	5.62	12.23	Pass

Note:

- Method 1 of power density measurement of KDB 662911 is using for calculating total power density. Total power density is summing entire spectra across corresponding frequency bins on the various outputs by computer.
- Directional gain = $6\text{dBi} + 10\log(3) = 10.77\text{dBi} > 6\text{dBi}$, so the power density limit shall be reduced to $17 - (10.77 - 6) = 12.23\text{dBm}$.
- Refer to section 3.3 for duty cycle spectrum plot.

802.11ac (VHT80)

Chan.	Freq. (MHz)	PSD w/o Duty Factor (dBm)			Duty Factor (dB)	Total PSD with Duty Factor (dBm)	Max. Limit (dBm)	Pass / Fail
		Chain 0	Chain 1	Chain 2				
42	5210	-4.82	-5.71	-5.31	0.17	-0.33	12.23	Pass

Note:

- Method 1 of power density measurement of KDB 662911 is using for calculating total power density. Total power density is summing entire spectra across corresponding frequency bins on the various outputs by computer.
- Directional gain = $6\text{dBi} + 10\log(3) = 10.77\text{dBi} > 6\text{dBi}$, so the power density limit shall be reduced to $17 - (10.77 - 6) = 12.23\text{dBm}$.
- Refer to section 3.3 for duty cycle spectrum plot.

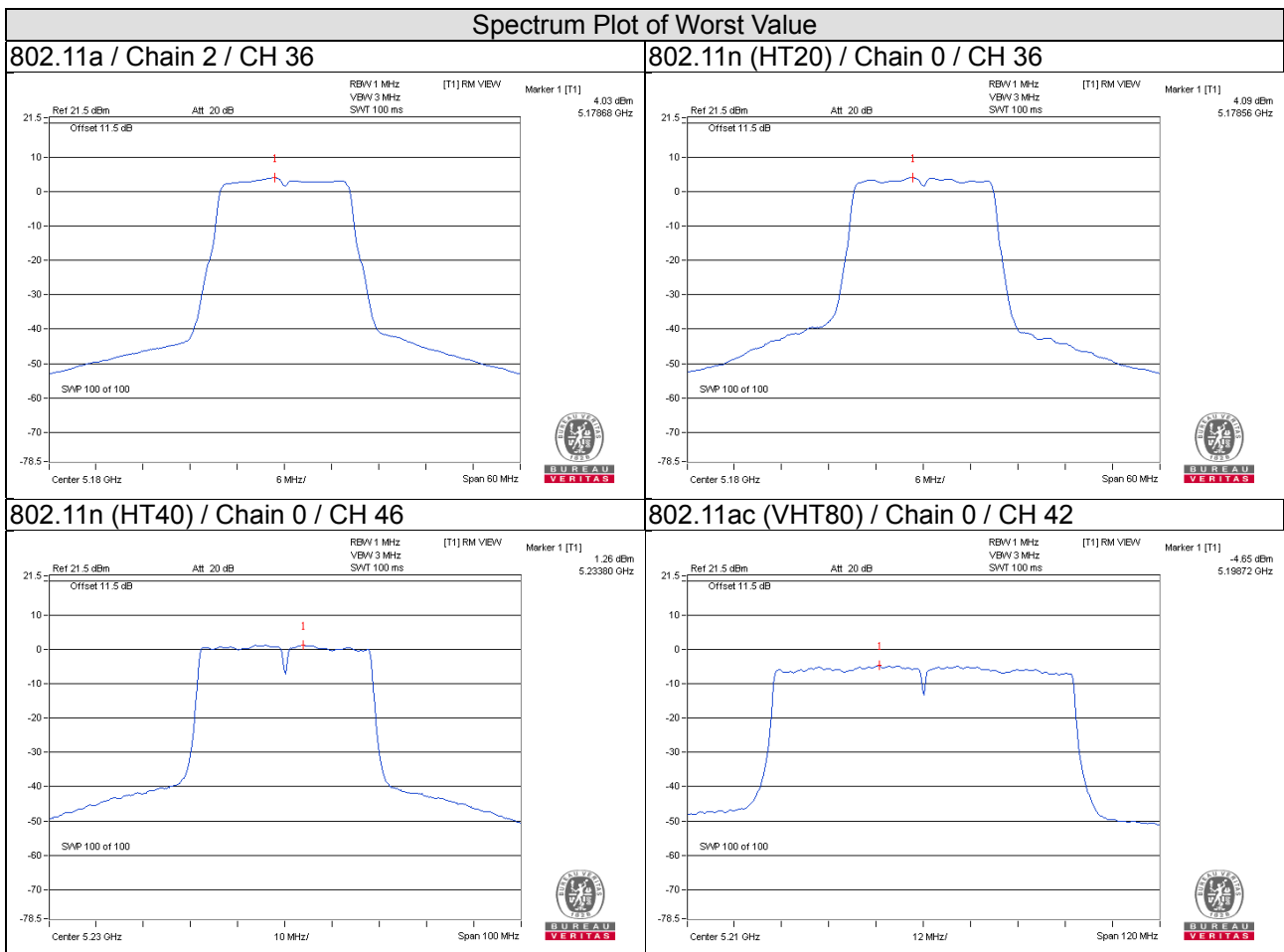

For U-NII-3 Band

802.11a

TX chain	Chan.	Freq. (MHz)	PSD (dBm/300 kHz)	PSD (dBm/500 kHz)	10 log (N=3) dB	Total PSD (dBm/500 kHz)	Limit (dBm/500 kHz)	Pass / Fail
0	149	5745	-1.99	0.23	4.77	5.00	25.23	Pass
	157	5785	-2.43	-0.21	4.77	4.56	25.23	Pass
	165	5825	-0.86	1.36	4.77	6.13	25.23	Pass
1	149	5745	-2.67	-0.45	4.77	4.32	25.23	Pass
	157	5785	-2.75	-0.53	4.77	4.24	25.23	Pass
	165	5825	-0.06	2.16	4.77	6.93	25.23	Pass
2	149	5745	-3.29	-1.07	4.77	3.70	25.23	Pass
	157	5785	-3.36	-1.14	4.77	3.63	25.23	Pass
	165	5825	-1.11	1.11	4.77	5.88	25.23	Pass

Note: Directional gain = 6dBi + 10log(3) = 10.77dBi > 6dBi, so the power density limit shall be reduced to 30-(10.77-6) = 25.23dBm.

802.11n (HT20)

TX chain	Chan.	Freq. (MHz)	PSD (dBm/300 kHz)	PSD (dBm/500 kHz)	10 log (N=3) dB	Total PSD (dBm/500 kHz)	Limit (dBm/500 kHz)	Pass / Fail
0	149	5745	-1.50	0.72	4.77	5.49	25.23	Pass
	157	5785	-2.76	-0.54	4.77	4.23	25.23	Pass
	165	5825	-0.26	1.96	4.77	6.73	25.23	Pass
1	149	5745	-1.88	0.34	4.77	5.11	25.23	Pass
	157	5785	-3.04	-0.82	4.77	3.95	25.23	Pass
	165	5825	0.55	2.77	4.77	7.54	25.23	Pass
2	149	5745	-2.71	-0.49	4.77	4.28	25.23	Pass
	157	5785	-3.84	-1.62	4.77	3.15	25.23	Pass
	165	5825	-0.32	1.90	4.77	6.67	25.23	Pass

Note: Directional gain = 6dBi + 10log(3) = 10.77dBi > 6dBi, so the power density limit shall be reduced to 30-(10.77-6) = 25.23dBm.

802.11n (HT40)

TX chain	Chan.	Freq. (MHz)	PSD w/o Duty Factor		10 log (N=3) dB	Duty Factor (dB)	Total PSD with Duty Factor (dBm/500kHz)	Limit (dBm/500 kHz)	Pass / Fail
			(dBm/300kHz)	(dBm/500kHz)					
0	151	5755	-5.02	-2.80	4.77	0.14	2.11	25.23	Pass
	159	5795	-3.99	-1.77	4.77	0.14	3.14	25.23	Pass
1	151	5755	-5.38	-3.16	4.77	0.14	1.75	25.23	Pass
	159	5795	-3.87	-1.65	4.77	0.14	3.26	25.23	Pass
2	151	5755	-6.06	-3.84	4.77	0.14	1.07	25.23	Pass
	159	5795	-4.64	-2.42	4.77	0.14	2.49	25.23	Pass

Note:

1. Directional gain = $6\text{dBi} + 10\log(3) = 10.77\text{dBi} > 6\text{dBi}$, so the power density limit shall be reduced to $30 - (10.77 - 6) = 25.23\text{dBm}$.
2. Refer to section 3.3 for duty cycle spectrum plot.

802.11ac (VHT80)

TX chain	Chan.	Freq. (MHz)	PSD w/o Duty Factor		10 log (N=3) dB	Duty Factor (dB)	Total PSD with Duty Factor (dBm/500kHz)	Limit (dBm/500 kHz)	Pass / Fail
			(dBm/300kHz)	(dBm/500kHz)					
0	155	5775	-17.01	-14.79	4.77	0.17	-9.85	25.23	Pass
1	155	5775	-17.60	-15.38	4.77	0.17	-10.44	25.23	Pass
2	155	5775	-18.06	-15.84	4.77	0.17	-10.90	25.23	Pass

Note:

1. Directional gain = $6\text{dBi} + 10\log(3) = 10.77\text{dBi} > 6\text{dBi}$, so the power density limit shall be reduced to $30 - (10.77 - 6) = 25.23\text{dBm}$.
2. Refer to section 3.3 for duty cycle spectrum plot.

Spectrum Plot of Worst Value

802.11a

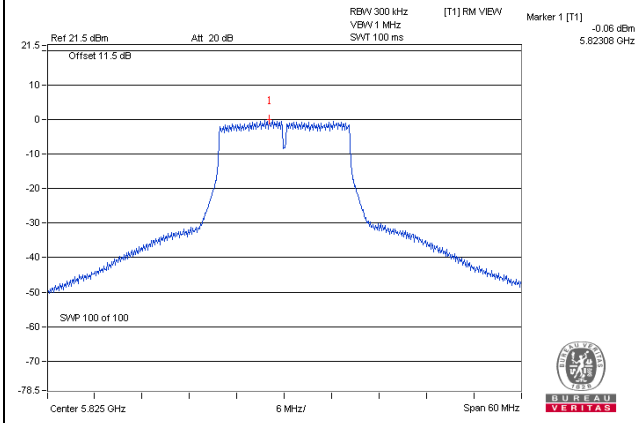

802.11n (HT20)

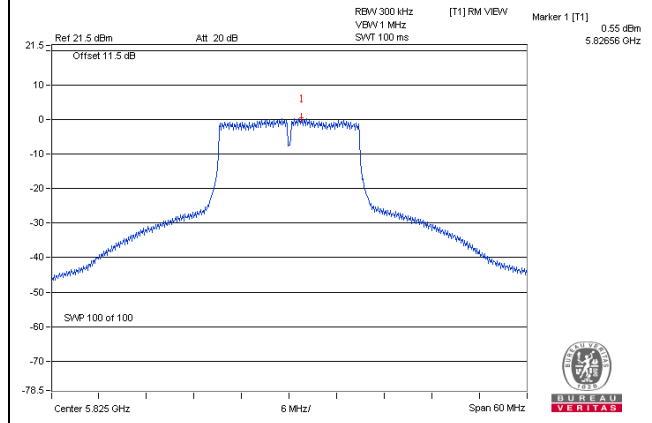

802.11n (HT40)

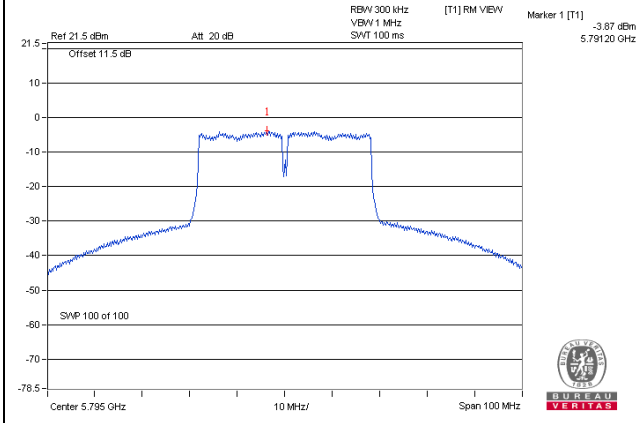

802.11ac (VHT80)

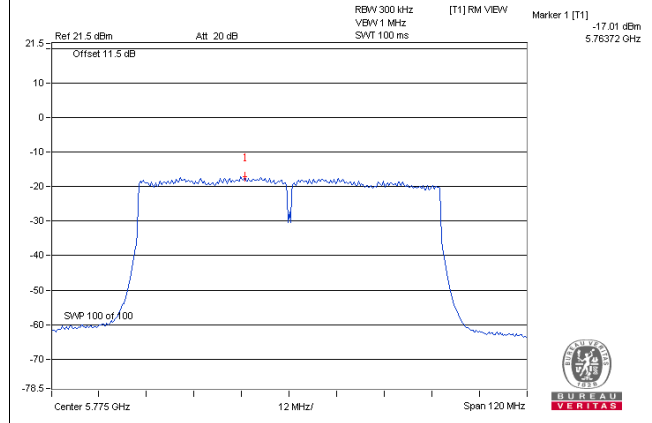

4.6 Frequency Stability

4.6.1 Limits of Frequency Stability Measurement

The frequency of the carrier signal shall be maintained within band of operation

4.6.2 Test Setup

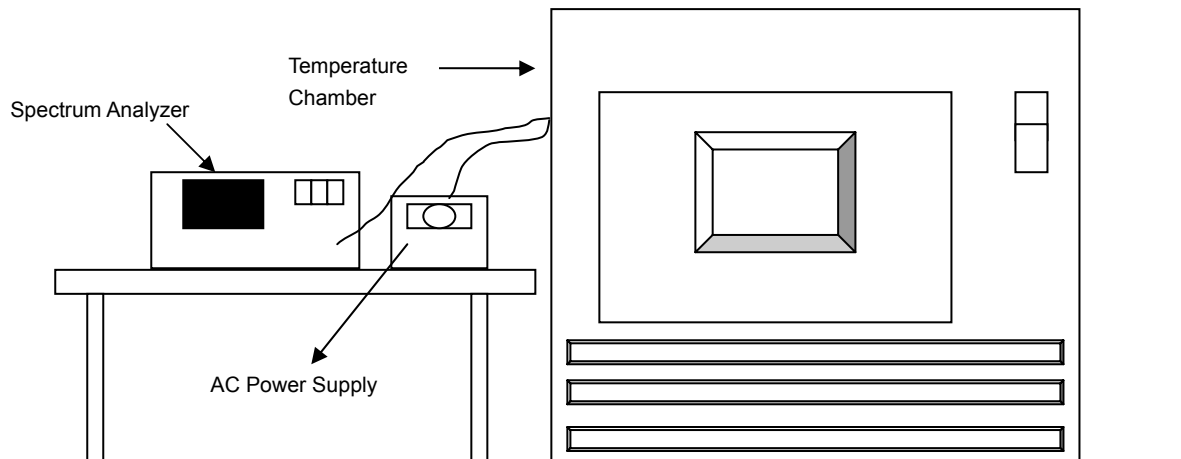

4.6.3 Test Procedure

- The EUT was placed inside the environmental test chamber and powered by nominal AC voltage.
- Turn the EUT on and couple its output to a spectrum analyzer.
- Turn the EUT off and set the chamber to the highest temperature specified.
- Allow sufficient time (approximately 30 min) for the temperature of the chamber to stabilize, turn the EUT on and measure the operating frequency after 2, 5, and 10 minutes.
- Repeat step 2 and 3 with the temperature chamber set to the lowest temperature.
- The test chamber was allowed to stabilize at +20 degree C for a minimum of 30 minutes. The supply voltage was then adjusted on the EUT from 85% to 115% and the frequency record.

4.6.4 Deviation from Test Standard

No deviation.

4.6.5 EUT Operating Condition

Set the EUT transmit at un-modulation mode to test frequency stability.

4.6.6 Test Results

Frequency Stability Versus Temp.									
Operating Frequency: 5240MHz									
Temp. (°C)	Power Supply (Vac)	0 Minute		2 Minute		5 Minute		10 Minute	
		Measured Frequency(MHz)	Frequency Drift (%)	Measured Frequency(MHz)	Frequency Drift (%)	Measured Frequency(MHz)	Frequency Drift (%)	Measured Frequency(MHz)	Frequency Drift (%)
50	120	5240.0156	0.00030	5240.0162	0.00031	5240.0201	0.00038	5240.0159	0.00030
40	120	5239.9885	-0.00022	5239.9895	-0.00020	5239.9893	-0.00020	5239.9861	-0.00027
30	120	5239.9971	-0.00006	5239.9966	-0.00006	5239.9956	-0.00008	5239.9965	-0.00007
20	120	5240.009	0.00017	5240.0092	0.00018	5240.0072	0.00014	5240.0098	0.00019
10	120	5240.0076	0.00015	5240.01	0.00019	5240.0063	0.00012	5240.0106	0.00020
0	120	5239.9791	-0.00040	5239.9819	-0.00035	5239.9785	-0.00041	5239.979	-0.00040
-10	120	5240.0172	0.00033	5240.0176	0.00034	5240.0212	0.00040	5240.0175	0.00033
-20	120	5240.0136	0.00026	5240.0102	0.00019	5240.0118	0.00023	5240.0139	0.00027
-30	120	5240.001	0.00002	5239.9996	-0.00001	5240.0018	0.00003	5239.9994	-0.00001

Frequency Stability Versus Voltage									
Operating Frequency: 5240MHz									
Temp. (°C)	Power Supply (Vac)	0 Minute		2 Minute		5 Minute		10 Minute	
		Measured Frequency(MHz)	Frequency Drift (%)	Measured Frequency(MHz)	Frequency Drift (%)	Measured Frequency(MHz)	Frequency Drift (%)	Measured Frequency(MHz)	Frequency Drift (%)
20	138	5240.0086	0.00016	5240.0092	0.00018	5240.0069	0.00013	5240.0107	0.00020
	120	5240.009	0.00017	5240.0092	0.00018	5240.0072	0.00014	5240.0098	0.00019
	102	5240.0094	0.00018	5240.0099	0.00019	5240.0074	0.00014	5240.0095	0.00018

4.7 6dB Bandwidth Measurement

4.7.1 Limits of 6dB Bandwidth Measurement

The minimum of 6dB Bandwidth Measurement is 0.5MHz.

4.7.2 Test Setup

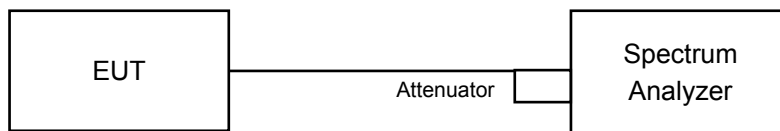

4.7.3 Test Instruments

Refer to section 4.1.2 to get information of above instrument.

4.7.4 Test Procedure

MEASUREMENT PROCEDURE REF

- Set resolution bandwidth (RBW) = 100kHz
- Set the video bandwidth (VBW) $\geq 3 \times$ RBW, Detector = Peak.
- Trace mode = max hold.
- Sweep = auto couple.
- Measure the maximum width of the emission that is constrained by the frequencies associated with the two amplitude points (upper and lower) that are attenuated by 6 dB relative to the maximum level measured in the fundamental emission

4.7.5 Deviation from Test Standard

No deviation.

4.7.6 EUT Operating Condition

The software provided by client to enable the EUT under transmission condition continuously at lowest, middle and highest channel frequencies individually.

4.7.7 Test Results

802.11a

Channel	Frequency (MHz)	6dB Bandwidth (MHz)			Minimum Limit (MHz)	Pass / Fail
		Chain 0	Chain 1	Chain 2		
149	5745	16.40	16.40	16.39	0.5	Pass
157	5785	16.42	16.42	16.44	0.5	Pass
165	5825	16.41	16.40	16.43	0.5	Pass

802.11n (HT20)

Channel	Frequency (MHz)	6dB Bandwidth (MHz)			Minimum Limit (MHz)	Pass / Fail
		Chain 0	Chain 1	Chain 2		
149	5745	17.63	17.67	17.65	0.5	Pass
157	5785	17.64	17.68	17.68	0.5	Pass
165	5825	17.64	17.66	17.67	0.5	Pass

802.11n (HT40)

Channel	Frequency (MHz)	6dB Bandwidth (MHz)			Minimum Limit (MHz)	Pass / Fail
		Chain 0	Chain 1	Chain 2		
151	5755	36.46	36.46	36.44	0.5	Pass
159	5795	36.46	36.47	36.44	0.5	Pass

802.11ac (VHT80)

Channel	Frequency (MHz)	6dB Bandwidth (MHz)			Minimum Limit (MHz)	Pass / Fail
		Chain 0	Chain 1	Chain 2		
155	5775	76.00	76.47	76.42	0.5	Pass

Spectrum Plot of Worst Value

802.11a

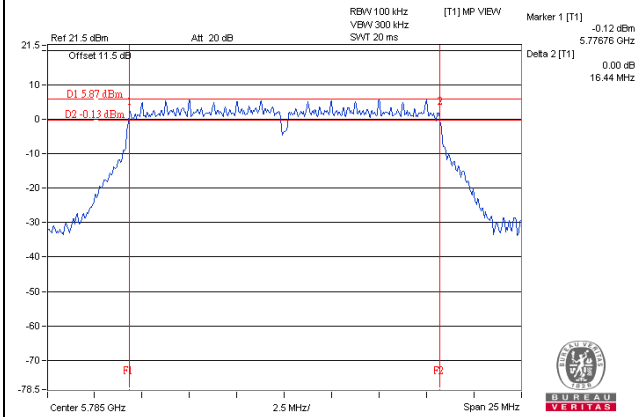

802.11n (HT20)

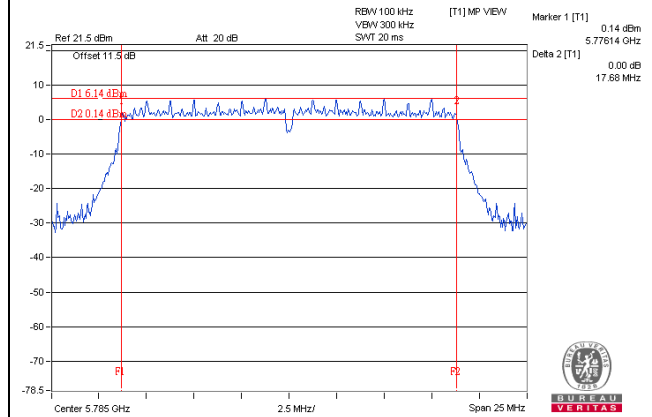

802.11n (HT40)

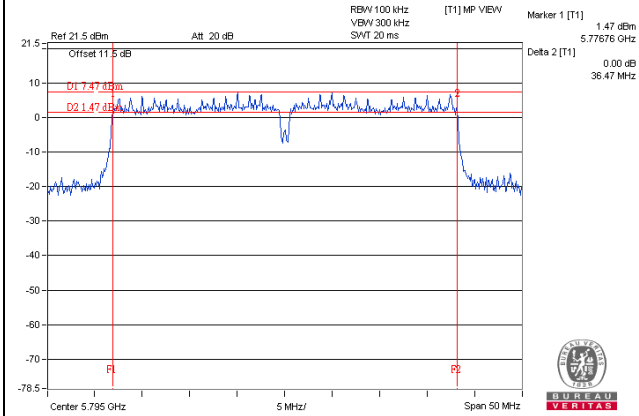

802.11ac (VHT80)

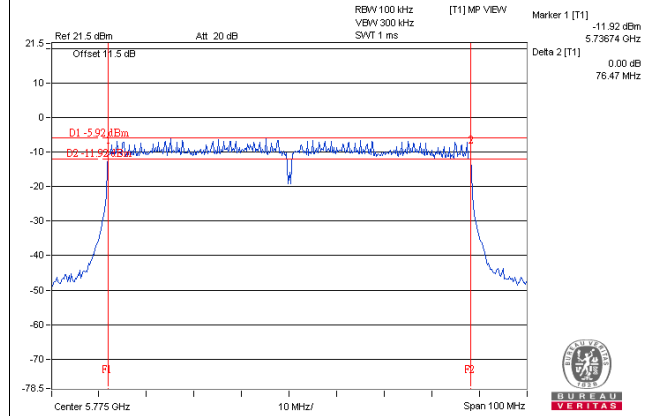

5 Pictures of Test Arrangements

Please refer to the attached file (Test Setup Photo).

Annex A- Radiated Out of Band Emission (OOBE) Measurement (For U-NII-3 band)

802.11a

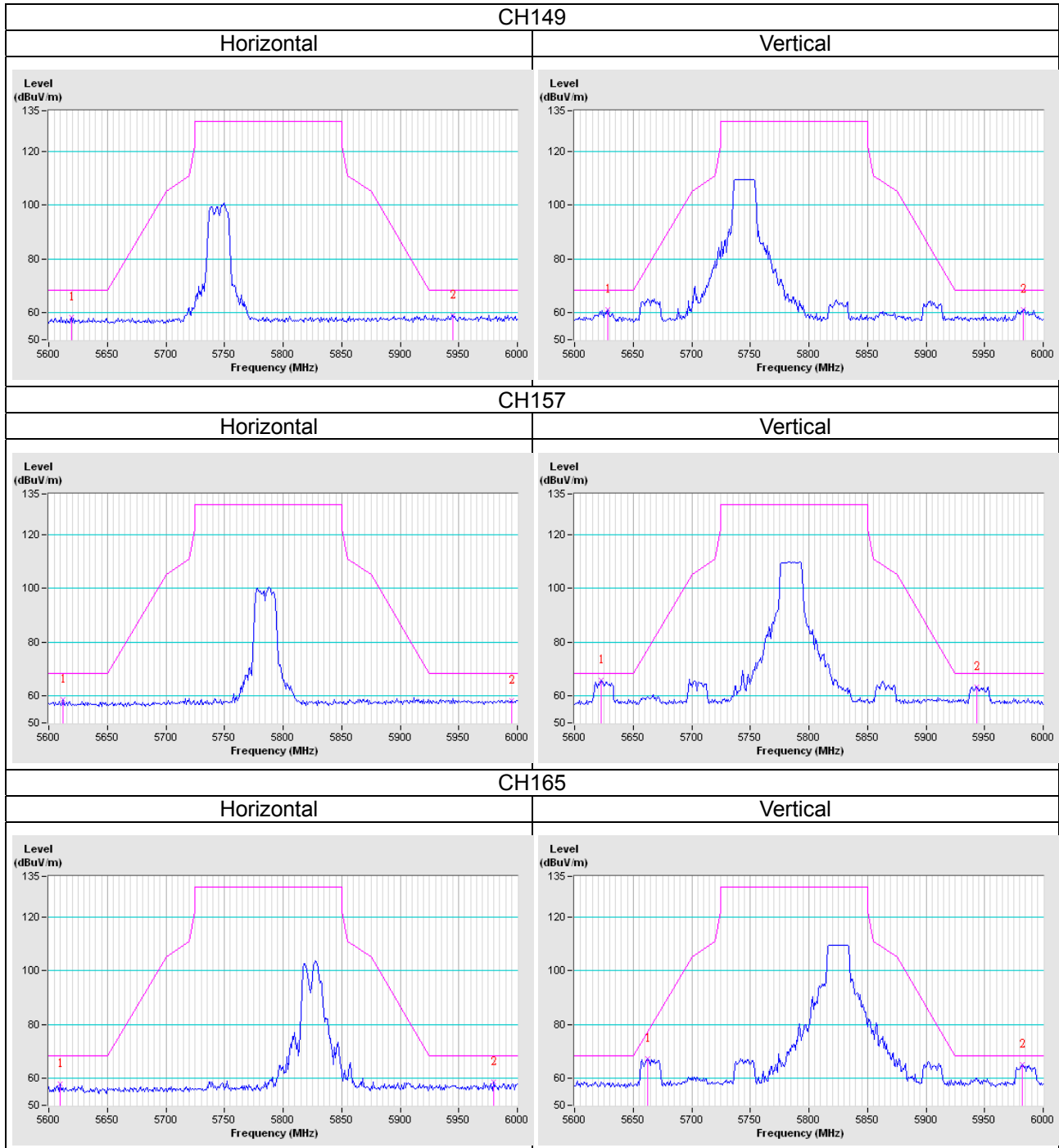

802.11n (HT20)

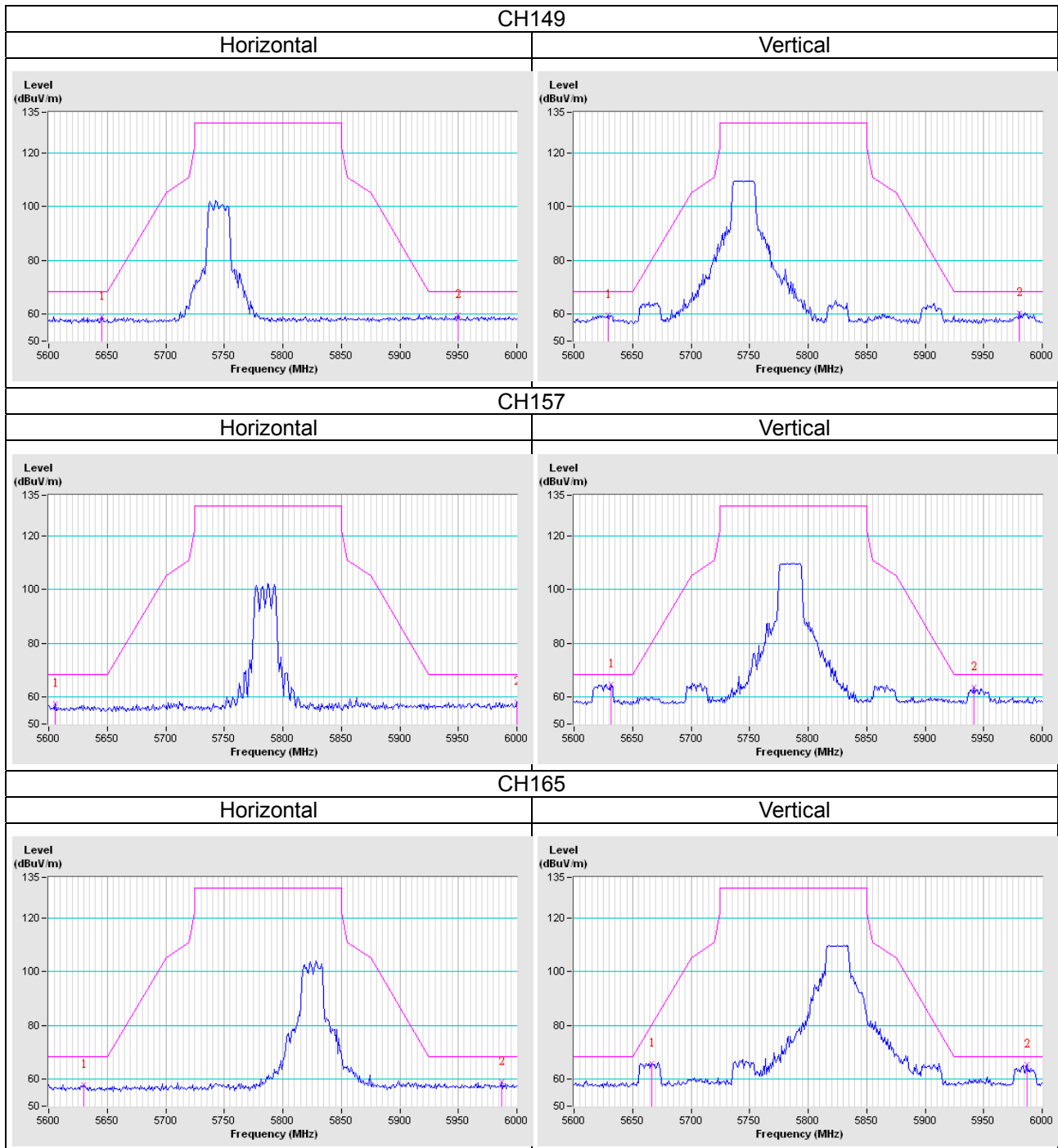

802.11n (HT40)

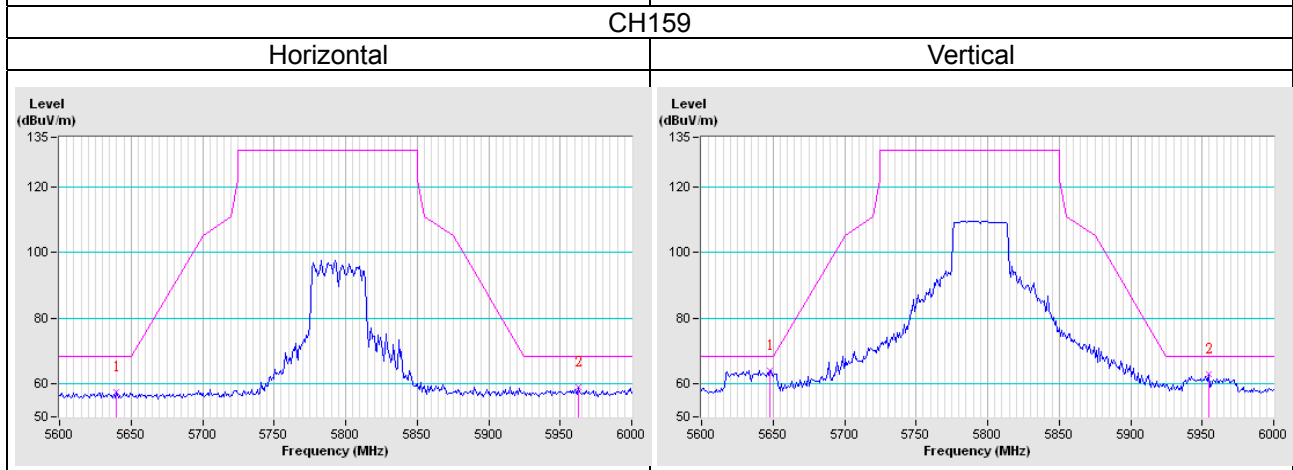
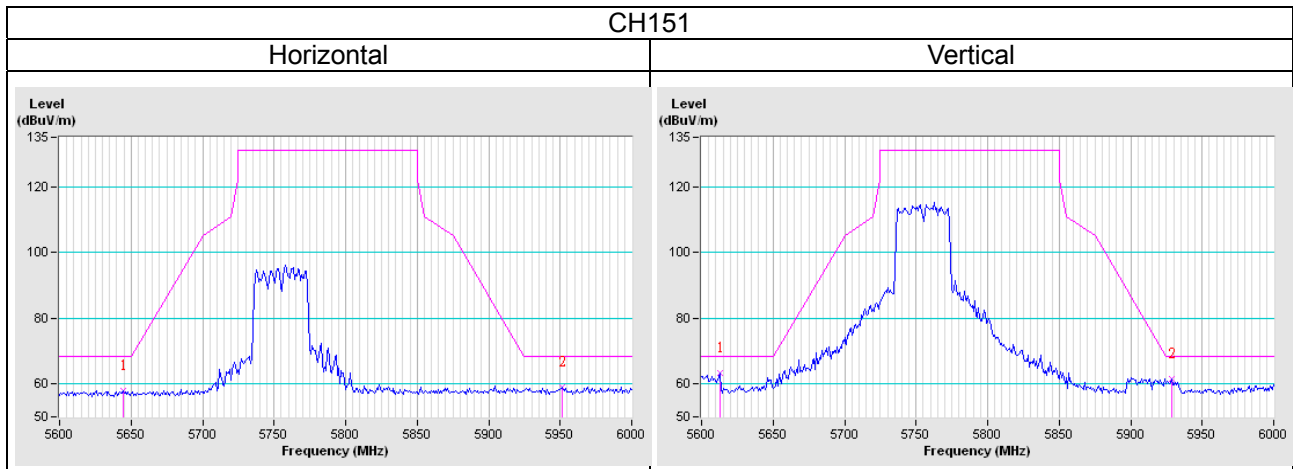

802.11ac (VHT80)

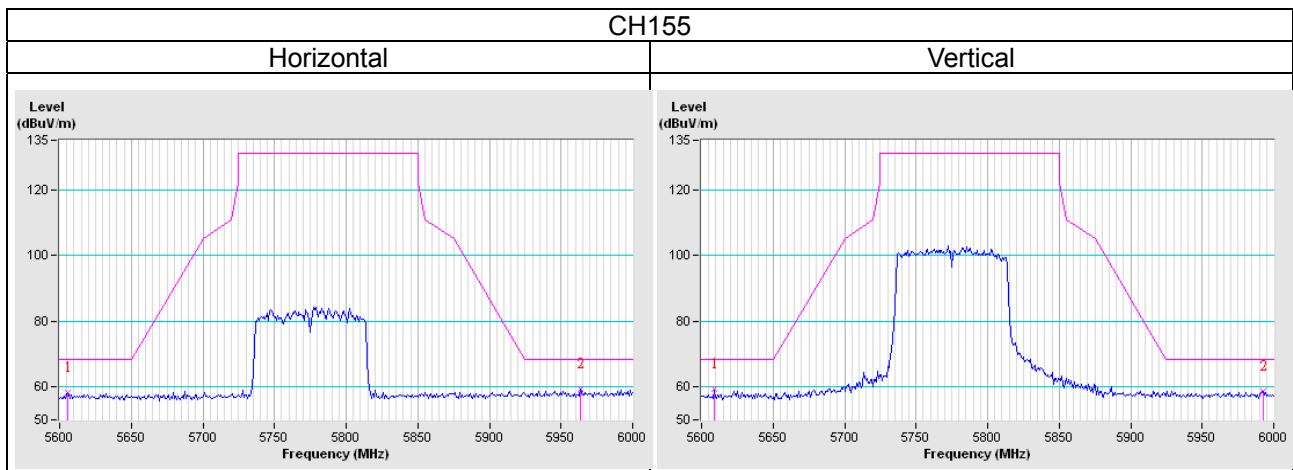

Appendix – Information on the Testing Laboratories

We, Bureau Veritas Consumer Products Services (H.K.) Ltd., Taoyuan Branch, were founded in 1988 to provide our best service in EMC, Radio, Telecom and Safety consultation. Our laboratories are accredited and approved according to ISO/IEC 17025.

If you have any comments, please feel free to contact us at the following:

Linko EMC/RF Lab

Tel: 886-2-26052180

Fax: 886-2-26051924

Hsin Chu EMC/RF/Telecom Lab

Tel: 886-3-6668565

Fax: 886-3-6668323

Hwa Ya EMC/RF/Safety Lab

Tel: 886-3-3183232

Fax: 886-3-3270892

Email: service.adt@tw.bureauveritas.com

Web Site: www.bureauveritas-adt.com

The address and road map of all our labs can be found in our web site also.

--- END ---