

TEST REPORT (SAR EVALUATION)

Applicant : I&C Technology Co., Ltd.
Address : (Sampyeong-dong, I&C Building), 24, Pangyo-ro255beon-gil,
Bundang-gu, Seongnam-si, South Korea

Products : Dual Module
Model No. : WFM60-SFP2501
Serial No. : --
FCC ID : 2ADXS-WFM60-SFP2501

Test Standard : FCC Rules and Regulations Title 47 CFR Part 2

Test Results : Passed

Date of Test : March 8, 2019



Kousei Shibata
Manager
Japan Quality Assurance Organization
KITA-KANSAI Testing Center
SAITO EMC Branch
7-3-10, Saito-asagi, Ibaraki-shi, Osaka 567-0085, Japan

-
- The test results in this test report was made by using the measuring instruments which are traceable to national standards of measurement in accordance with ISO/IEC 17025.
 - The applicable standard, testing condition and testing method which were used for the tests are based on the request of the applicant.
 - The test results presented in this report relate only to the offered test sample.
 - The contents of this test report cannot be used for the purposes, such as advertisement for consumers.
 - This test report shall not be reproduced except in full without the written approval of JQA.
 - VLAC does not approve, certify or warrant the product by this test report.

TABLE OF CONTENTS

	Page
1 Description of the Device Under Test (DUT)	3
2 Summary of Test Results	5
3 Test Procedure	6
4 Test Location	6
5 Recognition of Test Laboratory	6
6 Measurement System Diagram	7
7 System Components	8
8 Measurement Process	10
9 Measurement Uncertainties	11
10 Test Arrangement	12
11 Tissue Verification	14
12 System Performance Check	17
13 RF Output Power Measurements	18
14 SAR Measurements	19
15 Test Setup Photographs	21
16 Test Instruments	22
17 Appendix	23

1 Description of the Device Under Test (DUT)

1.1 General Information

1. **Manufacturer** : I&C Technology Co., Ltd.
(Sampyeong-dong, I&C Building), 24, Pangyo-ro255beon-gil,
Bundang-gu, Seongnam-si, South Korea
2. **Products** : Dual Module
3. **Model No.** : WFM60-SFP2501
4. **Serial No.** : --
5. **Transmitting Frequency** : WLAN 2.4 GHz (DTS : 2412 MHz – 2462 MHz)
WLAN 5 GHz (U-NII 1 : 5150 MHz – 5250 MHz)
WLAN 5 GHz (U-NII 2A : 5250 MHz – 5350 MHz)
WLAN 5 GHz (U-NII 2C : 5470 MHz – 5725 MHz)
WLAN 5 GHz (U-NII 3 : 5725 MHz – 5850 MHz)
6. **Power Rating** : 3.3VDC
7. **EUT Grounding** : None
8. **Device Category** : Portable Device (§2.1093)
9. **Exposure Category** : General Population/Uncontrolled Exposure
10. **FCC Rule Part(s)** : 15.247, 15.407
11. **EUT Authorization** : Certification
12. **Received Date of EUT** : December 7, 2018

1.2 Host Device Information

1. **Manufacturer** : Seiko Instruments Inc.
8, Nakase 1-chome, Mihama-ku, Chiba-shi, Chiba 261-8507, Japan
2. **Products** : Thermal Printer
3. **Model No.** : MP-B30-W02JK1U
4. **Serial No.** : EB000030A0
5. **Product Type** : Pre-production
6. **Date of Manufacture** : November, 2018
7. **Battery Option** : Lithium-ion Battery BP-A0720-B1 (1950mAh)

1.3 Wireless Technologies

Air Interface	Description	
WLAN (DTS)	Frequency band(s)	2.4 GHz
	Operating mode	802.11b 802.11g 802.11n [HT20]
WLAN (U-NII)	Frequency band(s)	5 GHz
	Operating mode	802.11a 802.11n [HT20]
	TDWR (Terminal Doppler Weather Rader)	Supported
	Band gap channel	Not supported

1.4 Maximum Output Power

Mode	Ch#	Max. Tune-up Limit (dBm)		
		802.11b	802.11g	802.11n [HT20]
WLAN 2.4 GHz (DTS)	1	14.5	16.0	15.5
	6	18.0	16.5	16.0
	11	18.5	17.0	16.5

Mode	Ch#	Max. Tune-up Limit (dBm)	
		802.11a	802.11n [HT20]
WLAN 5 GHz (UNII)	36	14.5	13.5
	40	14.0	12.0
	44	14.0	12.0
	48	14.3	12.5
	52	14.3	12.5
	56	14.3	12.5
	60	14.0	14.0
	64	13.0	14.5
	100	13.5	13.0
	120	12.5	11.0
	140	11.0	11.0
	149	14.0	13.5
	157	14.0	13.5
165	13.5	13.5	

2 Summary of Test Results

Applied Standard : FCC Rules and Regulations Title 47 CFR Part 2 – Frequency Allocations and Radio Treaty Matters; General Rules and Regulations
 §2.1093 Radiofrequency radiation exposure evaluation: portable devices

Test Configuration	Reported 1 g SAR (W/kg)			Limit (W/kg)
	Licensed	DTS	U-NII	
Body-worn	N/A	0.17	N/A	1.6
Simultaneous Transmission	N/A	N/A	N/A	

The test results are **passed** for exposure limits specified in ANSI/IEEE Std. C95.1.

In the approval of test results,

- Determining compliance with the limits in this report was based on the results of the compliance measurement, not taking into account measurement instrumentation uncertainty.
- No deviations were employed from the applied standard.
- No modifications were conducted by JQA to achieve compliance to the limitations.

Reviewed by:

Tested by:



Shigeru Kinoshita
 Assistant Manager
 JQA KITA-KANSAI Testing Center
 SAITO EMC Branch

Yasuhisa Sakai
 Manager
 JQA KITA-KANSAI Testing Center
 SAITO EMC Branch

3 Test Procedure

The tests documented in this report were performed in accordance with FCC 47 CFR §2.1093, IEEE Std.1528–2013 and the following KDB Procedures.

248227 D01 802.11 Wi-Fi SAR v02r02

447498 D01 General RF Exposure Guidance v06

865664 D01 SAR Measurement 100 MHz to 6 GHz v01r04

865664 D02 RF Exposure Reporting v01r02

4 Test Location

Japan Quality Assurance Organization (JQA)

KITA-KANSAI Testing Center

7-7, Ishimaru, 1-chome, Minoh-shi, Osaka, 562-0027, Japan

SAITO EMC Branch

7-3-10, Saito-asagi, Ibaraki-shi, Osaka 567-0085, Japan

5 Recognition of Test Laboratory

JQA KITA-KANSAI Testing Center SAITO EMC Branch is accredited under ISO/IEC 17025 by following accreditation bodies and the test facility is registered by the following bodies.

VLAC Accreditation No. : VLAC-001-2 (Expiry date : March 30, 2020)

VCCI Registration No. : A-0002 (Expiry date : March 30, 2020)

FCC Accreditation No. : JP5008 (Expiry date : March 30, 2020)

IC Registration No. : 2079E-3, 2079E-4 (Expiry date : June 26, 2020)

BSMI Registration No. : SL2-IS-E-6006, SL2-IN-E-6006, SL2-R1/R2-E-6006, SL2-A1-E-6006
(Expiry date : September 14, 2019)

Accredited as conformity assessment body for Japan electrical appliances and material law by METI.
(Expiry date : February 22, 2019)

6 Measurement System Diagram

These measurements are performed using the DASY5 automated dosimetric assessment system (manufactured by Schmid & Partner Engineering AG (SPEAG) in Zürich, Switzerland). It consists of high precision robotics system, cell controller system, DASY5 measurement server, personal computer with DASY5 software, data acquisition electronic (DAE) circuit, the Electro-optical converter (EOC), near-field probe, and the twin SAM phantom containing the equivalent tissue. The robot is a six-axis industrial robot performing precise movements to position the probe to the location (points) of maximum electromagnetic field (EMF).

The Robot is connected to the cell controller to allow software manipulation of the robot. The DAE is connected to the EOC. The DAE performs the signal amplification, signal multiplexing, A/D conversion, offset measurements, mechanical surface detection, collision detection, etc. The EOC performs the conversion from the optical into digital electric signal of the DAE and transfers data to the DASY5 measurement server.

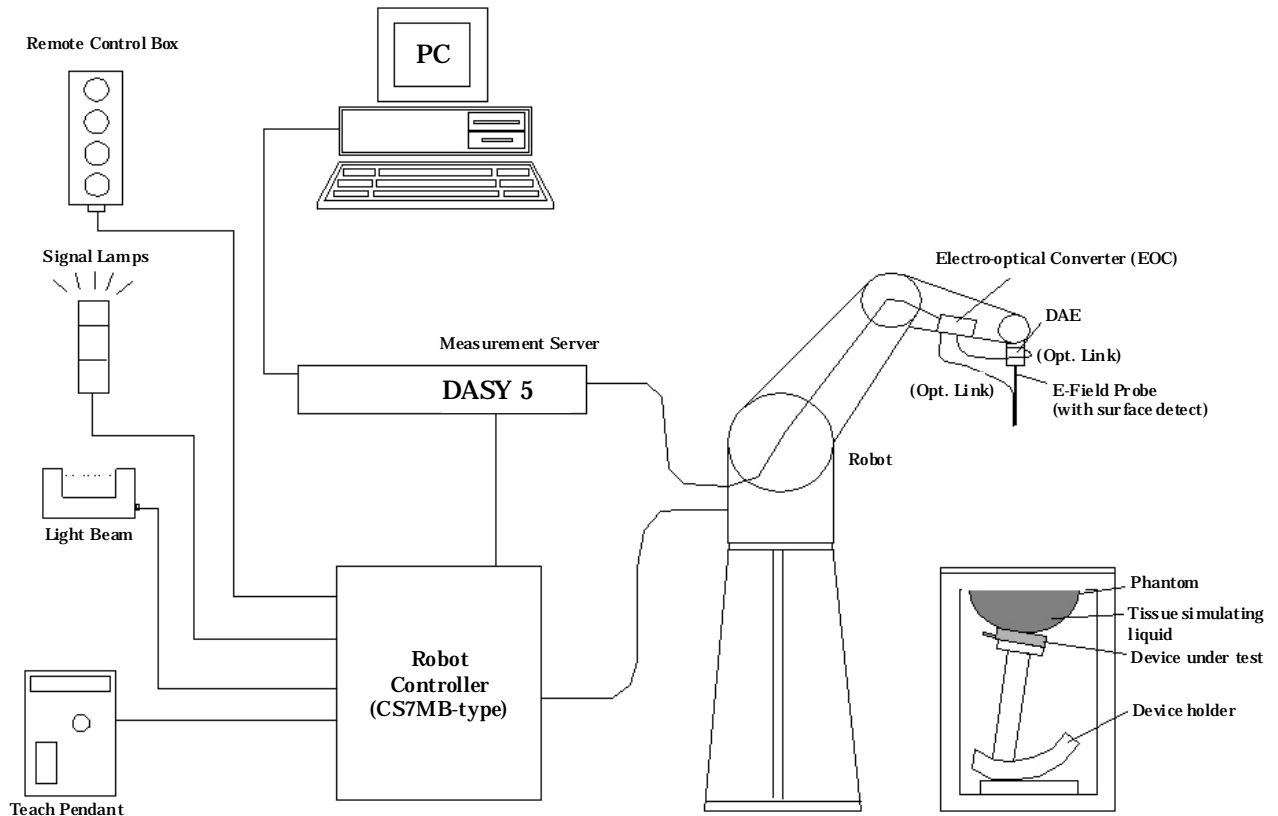

7 System Components

7.1 Probe Specification EX3DV4

Construction : Symmetrical design with triangular core
Built-in shielding against static charges
PEEK enclosure material (resistant to organic solvents, e.g., DGBE)

Calibration : In air form 10 MHz to 6 GHz
In head tissue simulating liquid (HSL) and
muscle tissue simulating liquid
2450 MHz (accuracy $\pm 12.0\%$; $k=2$)
5250 MHz (accuracy $\pm 13.1\%$; $k=2$)
5600 MHz (accuracy $\pm 13.1\%$; $k=2$)
5750 MHz (accuracy $\pm 13.1\%$; $k=2$)



Frequency : 10 MHz to 6 GHz
Linearity: ± 0.2 dB (30 MHz to 6 GHz)

Directivity : ± 0.3 dB in HSL (rotation around probe axis)
 ± 0.5 dB in tissue material (rotation normal to probe axis)

Dynamic Range : 10 μ W/g to >100 mW/g; Linearity: ± 0.2 dB (noise: typically < 1 μ W/g)

Dimensions : Overall length 337 mm
Tip length 20 mm
Body diameter 12 mm
Tip diameter 2.5 mm
Distance from probe tip to dipole centers 1 mm

7.2 Twin SAM Phantom

The shell corresponds to the specifications of the Specific Anthropomorphic Mannequin (SAM) phantom defined in IEEE 1528 and IEC 62209-1. It enables the dosimetric evaluation of left and right hand phone usage as well as body mounted usage at the flat phantom region. A cover prevents evaporation of the liquid. Reference markings on the phantom allow the complete setup of all predefined phantom positions and measurement grids by teaching three points with the robot.



Shell Thickness : 2 ± 0.2 mm; Center ear point: 6 ± 0.2 mm
Filling Volume : Volume Approx. 25 liters
Dimensions : $810 \times 1000 \times 500$ mm (H \times L \times W)

7.3 ELI4 Flat Phantom

Phantom for compliance testing of handheld and body-mounted wireless devices in the frequency range of 30 MHz to 6 GHz. ELI is fully compatible with the IEC 62209-2 standard and all known tissue simulating liquids. ELI has been optimized regarding its performance and can be integrated into our standard phantom tables. A cover prevents evaporation of the liquid. Reference markings on the phantom allow installation of the complete setup, including all predefined phantom positions and measurement grids, by teaching three points. The phantom is compatible with all SPEAG dosimetric probes and dipoles.

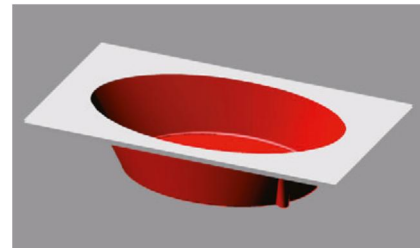

Shell Thickness : 2 ± 0.2 mm (sagging: <1%)
Filling Volume : Volume Approx. 30 liters
Dimensions : Major ellipse axis : 600 mm
Minor axis : 400 mm

7.4 Mounting Device for Transmitters

In combination with the Twin SAM Phantom V4.0/V4.0c or ELI4, the Mounting Device enables the rotation of the mounted transmitter device in spherical coordinates. Rotation point is the ear opening point. Transmitter devices can be easily and accurately positioned according to IEC, IEEE, CENELEC, FCC or other specifications. The device holder can be locked for positioning at different phantom sections (left head, right head, flat point).



8 Measurement Process

Step 1 : Power Reference Measurement

The power reference job measures the field at a specified reference position, at a selectable distance from the phantom surface. The reference position can be either the selected section's grid reference point or a user point in this section. The reference job projects the selected point onto the phantom surface, orients the probe perpendicularly to the surface, and approaches the surface using the selected detection method. The minimum distance of probe sensors to surface set to 4 mm for an ET3DV6 probe, or 2 mm for EX3DV4 probe. This distance cannot be smaller than the distance of sensor calibration points to probe tip as defined in the probe properties.

Step 2 : Area Scan

The area scan is used as a fast scan in two dimensions to find the area of high field values, before doing a fine measurement around the hot spot. The sophisticated interpolation routines implemented in DASY software can find the maximum locations in relatively coarse grids. When an area scan has measured all reachable points, it computes the field maximal found in the scanned area, within a range of the global maximum. If only one zoom scan follows the area scan, then only the absolute maximum will be taken as reference. For cases where multiple maxima within 2 dB of the maximum SAR value are detected, the number of zoom scans has to be increased accordingly.

Step 3 : Zoom Scan

Zoom scans are used to assess the peak spatial SAR values within a cubic averaging volume containing 1 g and 10 g of simulated tissue. The zoom scan measures points specified in standards within a cube whose base faces are centered on the maxima found in a preceding area scan job within the same procedure.

Step 4 : Z Scan

The Z scan measures points along a vertical straight line. The line runs along the Z axis of a one-dimensional grid. In order to get a reasonable extrapolation, the extrapolated distance should not be larger than the step size in Z-direction.

Step 5 : Power Drift Measurement

The power drift measurement measures the field at the same location as the most recent power reference measurement job within the same procedure, and with the same settings. The power drift measurement gives the field difference in dB from the reading conducted within the last power reference measurement. The power reference measurement and power drift measurement are for monitoring the power drift of the device under test in the batch process.

9 Measurement Uncertainties

Per KDB 865664 D01 SAR Measurement 100 MHz to 6 GHz, when the highest measured 1-g SAR within a frequency band is < 1.5 W/kg, the extensive SAR measurement uncertainty analysis described in IEEE Std. 1528-2013 is not required in SAR reports submitted for equipment approval.

10 Test Arrangement

10.1 RF Exposure Conditions

The body-supported devices include tablet type portable computers and credit card transaction authorization terminals, point-of-sale and/or inventory terminals. Where these devices may be torso or limb-supported, the same principles for body-supported devices are applied.

The SAR evaluation shall be performed for all surfaces of the DUT that are accessible during intended use. The separation distance in testing shall correspond to the intended use distance as specified in the user instructions provided by the manufacturer. If the intended use is not specified, all surfaces of the DUT shall be tested directly against the flat phantom.

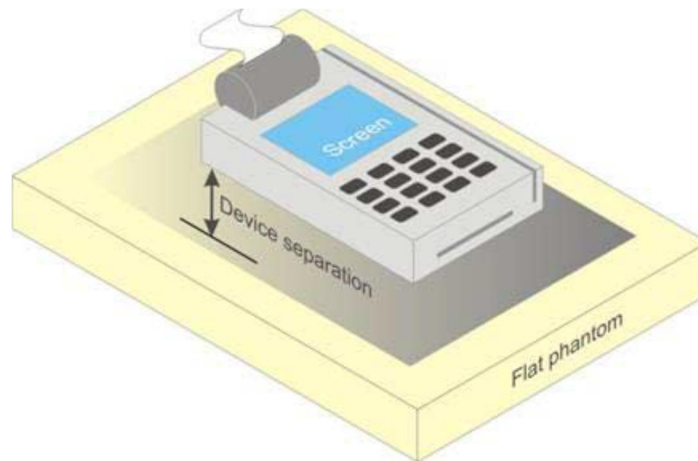

Test positions for a body-supported device

10.2 Antenna Location and Separation Distances

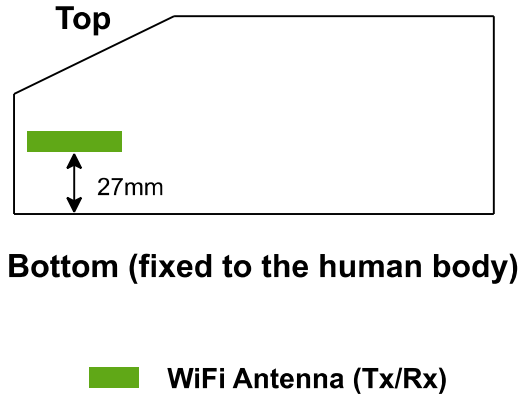

10.3 Standalone SAR Test Exclusion Considerations (KDB 447498 D01)

The 1 g SAR test exclusion thresholds for 100 MHz to 6 GHz at *test separation distances* ≤ 50 mm are determined by;

$$[(\text{max. power of channel, including tune-up tolerance, mW}) / (\text{min. test separation distance, mm})] \cdot [\sqrt{f_{\text{(GHz)}}}] \leq 3.0, \text{ where}$$

- $f_{\text{(GHz)}}$ is the RF channel transmit frequency in GHz.
- Power and distance are rounded to the nearest mW and mm before calculation.
- The result is rounded to one decimal place for comparison.
- When the minimum test separation distance is < 5 mm, a distance of 5 mm is applied.

Band	Freq. (MHz)	Max. Power		Test Position	Distance (mm)	Threshold	Test Exclusion
		(dBm)	(mW)				
WLAN (DTS)	2462	18.5	71	Bottom	27	4.1	NO
WLAN (U-NII 1)	5180	14.5	28	Bottom	27	2.4	YES
WLAN (U-NII 2A)	5280	14.3	27	Bottom	27	2.3	YES
WLAN (U-NII 2C)	5500	13.5	22	Bottom	27	1.9	YES
WLAN (U-NII 3)	5785	14.0	25	Bottom	27	2.2	YES

11 Tissue Verification

11.1 Tissue Verification Measurement Condition

The tissue dielectric parameters must be measured before the tissue-equivalent medium is used in a series of SAR measurements. The parameters should be re-measured after each 3 – 4 days of use, or earlier if dielectric parameters can become out of tolerance; for example, when the parameters are marginal at the beginning of the measurement series.

The temperature of the tissue-equivalent medium used during measurement must be within 18°C to 25°C and within ± 2°C of the temperature when the tissue parameters are characterized.

It is verified by using the dielectric probe and the network analyzer.

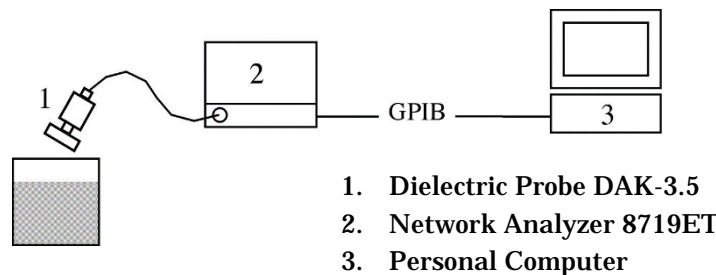

11.2 Tissue Dielectric Properties

The tissue dielectric properties are specified in KDB 865664 D01 Appendix A.

Target Frequency [MHz]	Head		Body	
	Permittivity (ϵ_r)	Conductivity (σ)	Permittivity (ϵ_r)	Conductivity (σ)
150	52.3	0.76	61.9	0.80
300	45.3	0.87	58.2	0.92
450	43.5	0.87	56.7	0.94
835	41.5	0.90	55.2	0.97
900	41.5	0.97	55.0	1.05
915	41.5	0.98	55.0	1.06
1450	40.5	1.20	54.0	1.30
1610	40.3	1.29	53.8	1.40
1800 – 2000	40.0	1.40	53.3	1.52
2450	39.2	1.80	52.7	1.95
3000	38.5	2.40	52.0	2.73
5800	35.3	5.27	48.2	6.00

For tissue dielectric properties at other frequencies within the range, a linear interpolation method shall be used.

11.3 Composition of Ingredients for the Tissue Material Used in the SAR Tests

The following tissue formulations are provided for reference only as some of the parameters have not been thoroughly verified. The composition of ingredients may be modified accordingly to achieve the desired target tissue parameters required for routine SAR evaluation.

Head and Body Liquids (Below 1 GHz)

Item	Head and Muscle Tissue Simulation Liquids HSL/MSL 750, HSL/MSL 900
H ₂ O	Water, 35 – 58 %
Sucrose	Sugar, white, refined, 40 – 60 %
NaCl	Sodium Chloride, 0 – 6 %
Hydroxyethyl-cellulose	Medium Viscosity (CAS# 9004-62-0), < 0.3 %
Preventol-D7	Preservative: aqueous preparation, (CAS# 55965-84-9), containing 5-chloro-2-methyl-3(2H)-isothiazolone and 2-methyl-3(2H)-isothiazolone, 0.1 – 0.7 %

Head and Body Liquids (1 to 3 GHz)

Item	Head and Muscle Tissue Simulation Liquids HSL/MSL 1750, HSL/MSL 1900, HSL/MSL 2450
H ₂ O	Water, 52 – 75 %
C ₈ H ₁₈ O ₃	Diethylene glycol monobutyl ether (DGBE), 25 – 48% (CAS-No. 112-34-5, EC-No. 203-961-6, EC-index-No. 603-096-00-8)
NaCl	Sodium Chloride, < 1.0 %

Head Liquids (3 to 6 GHz)

Item	Head Broad Band Tissue Simulation Liquids HBBL 3500-5800
Water	50 – 65 %
Mineral oil	10 – 30 %
Emulsifiers	8 – 25 %
Sodium salt	0 – 1.5 %
Safety relevant ingredients according to EU directives: EINECS-No 203-489-0 1.0 – 2.8 % 2-Methyl-pentane-2,4-diol (Hexylene Glycol): CAS-No 107-41-5 (Xi irritant, R36/38 irritant for eyes and skin)	

Body Liquids (3 to 6 GHz)

Item	Muscle Broad Band Tissue Simulation Liquids MBBL 3500-5800
Water	60 – 80 %
Esters, Emulsifiers, Inhibitors	20 – 40 %
Sodium salt	0 – 1.5 %
Safety relevant ingredients according to EU directives: none Safety relevant ingredients according to other directives: CAS-No 26399-02-0 10 – 28 % Oleic acid, alkylester	

11.4 Tissue Verification Results

Tissue dielectric parameters are measured at the low, middle and high frequency of each operating frequency range of the test device.

Date	Liquid	Frequency [MHz]	Parameters	Target	Measured	Deviation [%]	Limit [%]
3/8/2019	Body	2410	Permittivity (ϵ_r)	52.8	52.33	-0.89	± 5
			Conductivity (σ)	1.91	1.896	-0.73	± 5
		2450	Permittivity (ϵ_r)	52.7	52.20	-0.95	± 5
			Conductivity (σ)	1.95	1.950	+0.00	± 5
		2465	Permittivity (ϵ_r)	52.7	52.15	-1.04	± 5
			Conductivity (σ)	1.97	1.970	+0.00	± 5

12 System Performance Check

12.1 System Performance Check Measurement Condition

The power meter PM1 (including Attenuator) measures the forward power at the location of the validation dipole connector. The signal generator is adjusted for 250 mW (100 mW for 3 to 6 GHz) at the dipole connector and the power meter PM2 is read at that level. After connecting the cable to the dipole, the signal generator is readjusted for the same reading at power meter PM2.

The dipole antenna is matched to be used near flat phantom filled with tissue simulating solution. A specific distance holder is used in the positioning of the antenna to ensure correct spacing between the phantom and the dipole.

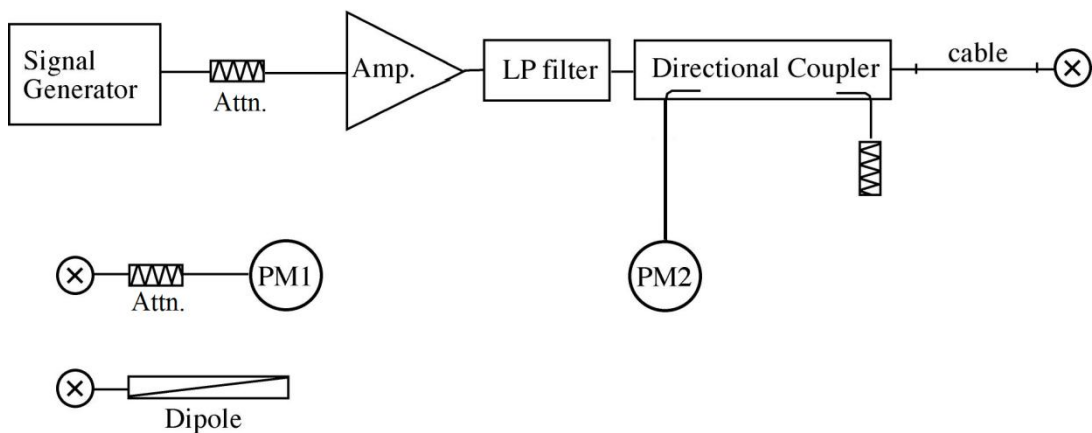

12.2 Target SAR Values for System Performance Check

The target SAR values can be obtained from the calibration certificate of system validation dipoles.

System Dipole		Cal. Date	Frequency [MHz]	Target SAR Values [W/kg]		
Type	Serial			1g/10g	Head	Body
D2450V2	714	8/13/2018	2450	1g	52.3	51.3
				10g	24.6	24.2

12.3 System Performance Check Results

The SAR measured with a system validation dipole, using the required tissue-equivalent medium at the test frequency, must be within 10 % of the manufacturer calibrated dipole SAR target.

Date	System Dipole		Liquid	Measured SAR [W/kg]		Target	Deviation [%]	Limit [%]
	Type	Serial		(Normalized to 1 W)				
3/8/2019	D2450V2	714	Body	1 g	51.60	51.3	+0.58	± 10
				10 g	24.28	24.2	+0.33	± 10

13 RF Output Power Measurements

DTS Band Results

Band	Mode	Data Rate	Ch#	Frequency (MHz)	Average Power (dBm)	
					Measured	Spec. Max.
2.4 GHz (DTS)	802.11b	1 Mbps	1	2412	14.01	14.5
			6	2437	17.85	18.0
			11	2462	18.12	18.5
	802.11g	6 Mbps	1	2412	15.75	16.0
			6	2437	15.95	16.5
			11	2462	16.88	17.0
	802.11n [HT20]	MCS 0	1	2412	15.36	15.5
			6	2437	15.68	16.0
			11	2462	15.90	16.5

Note(s):

Power measurement is required for the transmission mode configuration with the highest maximum output power specified for production units. (802.11b DSSS and 802.11g/n OFDM configurations are considered separately.)

- When the same highest maximum output power specification applies to multiple transmission modes, the largest channel bandwidth configuration with the lowest order modulation and lowest data rate is measured.
- When the same highest maximum output power is specified for multiple largest channel bandwidth configurations with the same lowest order modulation or lowest order modulation and lowest data rate, power measurement is required for all equivalent 802.11 configurations with the same maximum output power.

14 SAR Measurements

SAR test reduction criteria are as follows:

When 10 g extremity SAR is required, SAR values indicated below are multiplied by 2.5, i.e. the ratio of the 1 g and extremity 10 g SAR limit.

KDB 248227 D01 802.11 Wi-Fi SAR:

SAR test reduction is determined according to 802.11 transmission mode configurations and certain exposure conditions with multiple test positions. In the 2.4 GHz band, separate SAR procedures are applied to DSSS and OFDM configurations to simplify DSSS test requirements. For OFDM in both 2.4 GHz and 5 GHz bands, an initial test configuration is first determined for each standalone and aggregated frequency band according to the maximum output power and tune-up tolerance specified for production units. When the same maximum power is specified for multiple transmission modes in a frequency band, the largest channel bandwidth, lowest order modulation, lowest data rate and lowest order 802.11a/g/n/ac mode is used for SAR measurement, on the highest measured output power channel in the initial test configuration, for each frequency band.

SAR is measured using the highest measured maximum output power channel for the determined exposure configurations. When there are multiple test channels with the same measured maximum output power, the channel closest to mid-band frequency is selected for SAR measurement. When there are multiple test channels with the same measured maximum output power and equal separation from mid-band frequency; for example, high and low channels or two mid-band channels, the higher frequency (number) channel is selected for SAR measurement.

An initial test position is applied to further reduce the number of SAR tests for devices operating in next to the ear, UMPC mini-tablet or hotspot mode exposure configurations that require multiple test positions SAR is measured in the initial test position using the 802.11 transmission mode configuration required by the DSSS procedure or initial test configuration according to the OFDM procedures. The initial test position procedure is described in the following:

- When the reported SAR of the initial test position is ≤ 0.4 W/kg, further SAR measurement is not required for the other (remaining) test positions in that exposure configuration and 802.11 transmission mode combination within the frequency band or aggregated band.
- When the reported SAR of the initial test position is > 0.4 W/kg, SAR is repeated for the 802.11 transmission mode configuration tested in the initial test position using subsequent highest extrapolated or estimated 1 g SAR conditions determined by area scans or next closest/smallest test separation distance and maximum RF coupling test positions based on manufacturer justification, on the highest maximum output power channel, until the reported SAR is ≤ 0.8 W/kg or all required test positions (left, right, touch, tilt or subsequent surfaces and edges) are tested.
- For all positions/configurations tested using the initial test position and subsequent test positions, when the reported SAR is > 0.8 W/kg, SAR is measured for these test positions/configurations on the subsequent next highest measured output power channel(s) until the reported SAR is ≤ 1.2 W/kg or all required channels are tested.

To determine the initial test position, Area Scans were performed to determine the position with the estimated 1 g SAR (fast SAR). The position that produced the highest fast SAR is considered the worst case position; thus used as the initial test position. The averaged fast SAR is scaled according to reported SAR requirements.

14.1 WLAN (DTS Band)

802.11b (1 Mbps) – Duty Cycle 100%										
RF Exposure Conditions	Test Position	Dist. [mm]	Ch#	Freq. [MHz]	Averaged Fast SAR [W/kg]	Power [dBm]		1 g SAR [W/kg]		Plot No.
						Tune-up Limit	Meas.	Meas.	Scaled	
Body-worn	Bottom	0	11	2462	0.172	18.5	18.12	0.156	0.170	1

Note(s):

SAR is not required for 802.11g/n OFDM configurations when the highest reported SAR for DSSS is adjusted by the ratio of OFDM to DSSS specified maximum output power and the adjusted SAR is ≤ 1.2 W/kg.

14.2 SAR Measurement Variability

In accordance with the KDB 865664 D01, these additional measurements are repeated after the completion of all measurements requiring the same head or body tissue-equivalent medium in a frequency band. The DUT should be returned to ambient conditions (normal room temperature) with the battery fully charged before it is re-mounted on the device holder for the repeated measurement(s) to minimize any unexpected variations in the repeated results.

- 1) Repeated measurement is not required when the original highest measured SAR is < 0.80 W/kg; steps 2) through 4) do not apply.
- 2) When the original highest measured SAR is ≥ 0.80 W/kg, repeat that measurement once.
- 3) Perform a 2nd repeated measurement only if the ratio of largest to smallest SAR for the original and first repeated measurements is > 1.20 or when the original or repeated measurement is ≥ 1.45 W/kg (~ 10% from the 1-g SAR limit).
- 4) Perform a 3rd repeated measurement only if the original, first or second repeated measurement is ≥ 1.5 W/kg and the ratio of largest to smallest SAR for the original, first and second repeated measurements is > 1.20 .

14.2.1 Highest Measured SAR Configuration in Each Frequency Band

Frequency Band [MHz]	Air Interface	Standalone SAR [W/kg]
2450	WLAN 802.11b	0.156

14.2.2 Repeated SAR Measurement Results

Repeated SAR measurement is not required because the highest measured SAR is < 0.80 W/kg.

16 Test Instruments

Shielded Room S3				
Type	Model	Serial No. (ID)	Manufacturer	Cal. Due
E-Field Probe	EX3DV4	7321 (S-17)	SPEAG	2019/08/21
DAE	DAE4	508 (S-3)	SPEAG	2019/08/08
Robot	RX60L	F02/5R10A1/A/01 (S-7)	Stäubli	N/A
Probe Alignment Unit	LB5/80	SE UKS 030 AA (S-13)	SPEAG	N/A
Network Analyzer	E8357A	US41070304	Agilent	2019/10/11
Dielectric Probe	DAK-3.5	1124 (S-32)	SPEAG	2019/08/16
2450MHz Dipole	D2450V2	714 (S-6)	SPEAG	2019/08/12
Signal Generator	MG3710A	6201171711 (B-41)	Anritsu	2019/12/11
RF Power Amplifier	CGA020M602-2633R	B10840 (A-51)	R&K	N/A
Directional Coupler	4226-20	03736 (D-87)	Narda Microwave	N/A
Power Meter	E4417A	GB41290850 (B-51)	Agilent	2019/07/26
Power Sensor	E9323A	US40411939 (B-59)	Agilent	2019/07/25
Power Meter	N1911A	GB45100291 (B-63)	Agilent	2019/07/25
Power Sensor	N1921A	US44510470 (B-64)	Agilent	2019/07/25
Attenuator	2-20	BY7535 (D-36)	Weinschel	2019/10/30
Attenuator	2-10	AW7937 (D-40)	Weinschel	2019/10/30

NOTE : The calibration interval of the above test instruments is 12 months.

17 Appendix

Refer to separated files for the following appendixes.

Appendix 1 – System Performance Check Plots

Appendix 2 – Highest SAR Test Plots

Appendix 3 – Dosimetric E-Field Probe Calibration Data

Appendix 4 – System Validation Dipole Calibration Data