

WFM60-SFP2501

2.4GHz/5GHz
WLAN(IEEE 802.11a/b/g/n)
Stand-alone Module

August, 7, 2018

Rev. 0.3



TABLE OF CONTENTS

1. APPLICATION	3
2. QUALITY	3
3. APPEARANCE AND CHARACTERISTICS	3
3.1 APPEARANCE	3
3.2 CHARACTERISTICS	3
4. APPLICATION OF 2.4GHZ/5GHZ WLAN(802.11A/B/G/N) STAND-ALONE MODULE	3
5. ABSOLUTE MAXIMUM RATING	3
6. TEST	3
7. MECHANICAL DIMENSION	4
8. GENERAL DESCRIPTION	4
9. INPUT/OUTPUT DC TERMINAL CHARACTERISTICS	5
10 ELECTRICAL CHARACTERISTICS	5
10.1 OPERATING CONDITION	5
10.2 2.4GHZ TX CHARACTERISTICS	5
10.3 2.4GHZ RX CHARACTERISTICS	6
10.4 5GHZ TX CHARACTERISTICS	6
10.5 5GHZ RX CHARACTERISTICS	7
10.6 Power Consumption	7
11. PIN ASSIGNMENT (TOP VIEW, BOTTOM LAYER)	8
12. PIN DESCRIPTION	9
13. BLOCK DIAGRAM	10
14. POWER SEQUENCE	10
15. PACKING INFORMATION	11
15.1 CARRIER DIMENSION	11
15.2 CARRIER TAPE DIMENSION	11
16. REFLOW PROFILE	12
17. REVISION HISTORY	13

1. Application

This specification is applied to the 2.4GHz/5GHz WLAN(802.11a/b/g/n) Stand-Alone module of I&C TECHNOLOGY.

2. Quality

Quality should meet each condition which are mentioned on this specification. However, items which are not mentioned on this specification should follow the inspection agreements and standards which are agreed with both companies.

3. Appearance and Characteristics

3.1 Appearance

Appearance should not be contaminated by harmful materials and have cracks etc. Mechanical dimension should meet the contents of clause 7.

3.2 Characteristics

Electrical characteristics should meet the contents of clause 12.

4. Application of 2.4GHz/5GHz WLAN(802.11a/b/g/n) Stand-Alone Module

WFM60-SFP2501 is a 2.4GHz/5GHz WLAN(802.11a/b/g/n) Stand-Alone Module for IoT(Internet of Things) such as Home electronic appliance, Room controller, Smart plug, etc. But, this module is not designed for Life Support Application.

Also it is recommended that this module should be mounted by reflow soldering.

5. Absolute Maximum Rating

		Min.	Max.	Unit
Storage Temperature		-40	+85	deg.C
Supply Voltage	VBAT_SYS		3.6	V
	VDD_PA		3.6	
	VDDIO_1,2		3.6	
	VDD_BBPLL		3.6	
	VDD_MEM		4.0	

6. Test

Electrical characteristics are tested for every product. However, if there are any objections in judgment, it should be treated with agreements of companies.

7. Mechanical Dimension

Dimension	34.5mm× 17.0mm × 3.0mm(±0.1)
-----------	------------------------------

Figure 1 and Figure 2 show the Bottom Layer (Top View) and the side dimension of WFM60-SFP2501 package outline

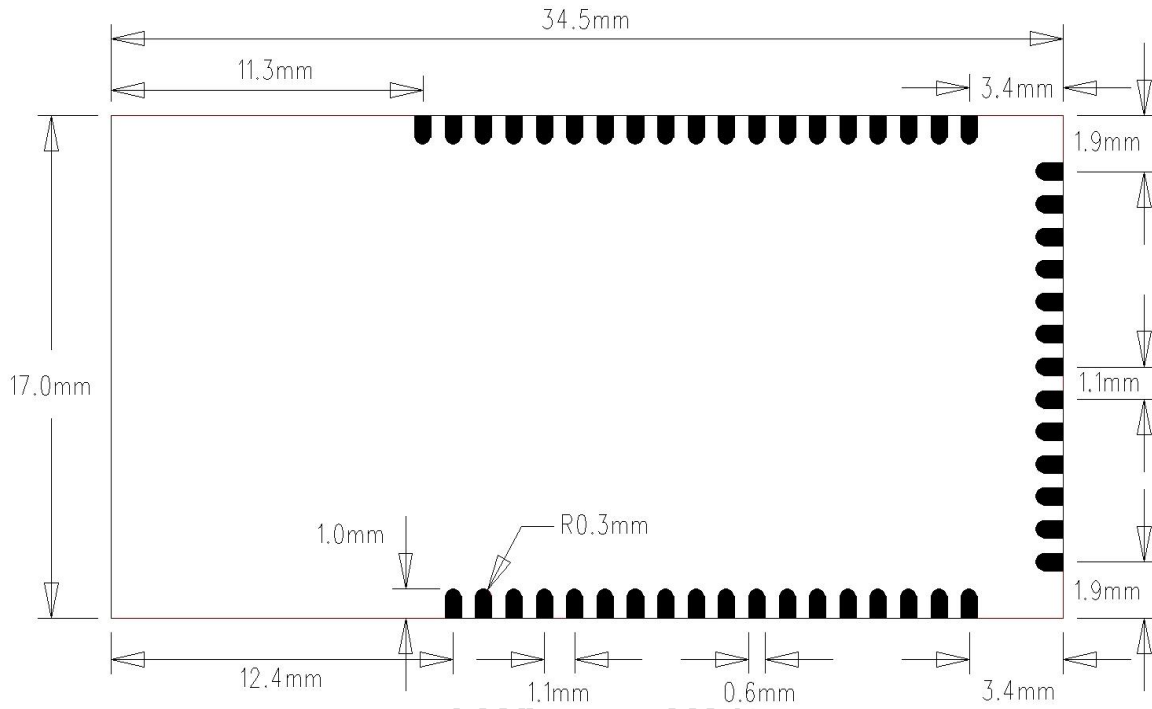

Figure 1. Package Outline (Top View)

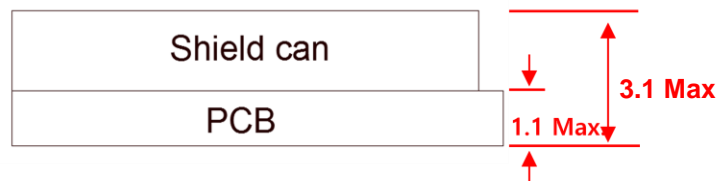

Figure 2. Package Outline (Side View)

8. General Description

WFM60-SFP2501 is a compact size and low power System-in-Package (SiP) for 2.4GHz/5GHz WLAN(802.11a/b/g/n) aimed at embedded and IoT applications.
 WFM60-SFP2501 can be available as 50 pin. (34.5mm x 17.0mm x Max. 3.0mm)

9. Input/Output DC Terminal Characteristics

	Parameters	Conditions	Min.	Typ.	Max.	Unit
V _{IH}	High Level Input Voltage	VDDIO=3.3V	2.1			V
V _{IL}	Low Level Input Voltage	VDDIO=3.3V			0.7	V
V _{OH}	High Level Output Voltage	VDDIO=3.3V	VDDIO-0.4			V
V _{OL}	Low Level Output Voltage	VDDIO=3.3V			0.4	V

10. Electrical Characteristics

10.1 Operating Condition

		Min.	Typ.	Max.	Unit
Operating Temperature		-30	25	85	deg.C
Supply Voltage	VDD_SYS	3.0	3.3	3.6	V
	VDD_PA	3.0	3.3	3.6	
	VDD_BBPLL	3.0	3.3	3.6	
	VDDIO_1,2	3.0	3.3	3.6	
	VDD_MEM	3.0	3.3	3.6	

* The optimal RF performance specified in this datasheet is guaranteed for temperatures from -20°C~+70°C

10.2 2.4GHz Tx Characteristics

All measurements are made under nominal supply voltage and tested at External Antenna Port.
 (VDD_SYS = 3.3V, VDD_PA =3.3V, VDDIO_1,2=3.3V, VDD_BBPLL=3.3V, VDD_MEM=3.3V)
 and room temperature(25°C) condition.

Parameters	Conditions	Spec.			
		Min.	Typ.	Max.	Unit
Frequency Range		2400	-	2500	MHz
Output Power (VBAT=3.3V, spectral mask, EVM compliance)	802. 11b, EVM = -9 dB		19.5		dBm
	OFDM , BPSK, EVM = -8 dB		18		
	OFDM, QPSK, EVM = -13 dB		17		
	OFDM, 16QAM, EVM = -19 dB		17		
	OFDM, 64QAM ^{3/4} , EVM = -25 dB		16		
	OFDM, 64QAM ^{5/6} , EVM = -28 dB		15		

10.3 2.4Ghz Rx Characteristics

All measurements are made under nominal supply voltage and tested at External Antenna Port. (VDD_SYS = 3.3V, VDD_PA =3.3V, VDDIO_1,2=3.3V, VDD_BBPLL=3.3V, VDD_MEM=3.3V) and room temperature (25°C) condition.

Parameters	Conditions	Spec.			
		Min.	Typ.	Max.	Unit
Frequency Range		2400	-	2500	MHz
11b, Rx Sensitivity (8% PER for 1024 octet PSDU)	CCK, 1 Mbps		-96.5		dBm
	CCK, 2 Mbps		-94.5		
	CCK, 5.5 Mbps		-92.5		
	CCK, 11 Mbps		-88.5		
11g, Rx Sensitivity (10% PER for 1024 octet PSDU)	OFDM, 6 Mbps		-93.5		
	OFDM, 9 Mbps		-92.5		
	OFDM, 12 Mbps		-90.5		
	OFDM, 18 Mbps		-88		
	OFDM, 24 Mbps		-85		
	OFDM, 36 Mbps		-82		
	OFDM, 48 Mbps		-77.5		
11n, Rx Sensitivity (10% PER for 4096 octet PSDU)	OFDM, 54 Mbps		-76		
	HT20, MCS0		-93.5		
	HT20, MCS1		-90		
	HT20, MCS2		-87.5		
	HT20, MCS3		-84.5		
	HT20, MCS4		-82		
	HT20, MCS5		-77		
Adjacent Channel Rejection	HT20, MCS6		-75		
	HT20, MCS7		-74		
	CCK, 1 Mbps (signal; -74dBm)	35	-		dB
	CCK, 11 Mbps (signal; -70dBm)	35	-		
OFDM, 6 Mbps (signal; -79dBm)	16	-			
OFDM, 54 Mbps (signal; -62dBm)	-1	-			
Max Input level	11b 1M,2M		0		dBm
	11b 5.5M, 11M		0		
	11g		-10		
	11n		-10		

10.4 5GHz band Tx Characteristics

All measurements are made under nominal supply voltage and tested at External Antenna Port. (VDD_SYS = 3.3V, VDD_PA =3.3V, VDDIO_1,2=3.3V, VDD_BBPLL=3.3V, VDD_MEM=3.3V) and room temperature (25°C) condition.

Parameters	Conditions	Spec.			
		Min.	Typ.	Max.	Unit
Frequency Range		4900	-	5845	MHz
Output Power (VBAT, VDD_FEM=3.3V, spectral mask, EVM compliance)	11a, OFDM, 64QAM 3/4, EVM = -25 dB		13.5		dBm
	11n, OFDM, 64QAM 5/6, EVM = -28 dB		12		

10.5 5GHz Rx Characteristics

All measurements are made under nominal supply voltage and tested at External Antenna Port.
(VDD_SYS = 3.3V, VDD_PA = 3.3V, VDDIO_1,2=3.3V, VDD_BBPLL=3.3V, VDD_MEM=3.3V)
and room temperature (25°C) condition.

Parameters	Conditions	Spec.			
		Min.	Typ.	Max.	Unit
Frequency Range		4900	-	5845	MHz
11a, Rx Sensitivity (10% PER for 1024 octet PSDU)	OFDM, 6 Mbps		-93		dBm
	OFDM, 9 Mbps		-92		
	OFDM, 12 Mbps		-90.5		
	OFDM, 18 Mbps		-87.5		
	OFDM, 24 Mbps		-84		
	OFDM, 36 Mbps		-80.5		
	OFDM, 48 Mbps		-76		
	OFDM, 54 Mbps		-74.5		
11n, Rx Sensitivity (10% PER for 4096 octet PSDU)	HT20, MCS0		-92.5		dBm
	HT20, MCS1		-89.5		
	HT20, MCS2		-87		
	HT20, MCS3		-85		
	HT20, MCS4		-82		
	HT20, MCS5		-75		
	HT20, MCS6		-73.5		
	HT20, MCS7		-72.5		
Adjacent Channel Rejection	11a, OFDM, 54Mbps (Signal : -62dBm)	-1			dBm
	11n, HT20, MCS7 (Signal : -61dBm)	-2			
Max Input level	11a/n		-20		dBm

10.6 Power Consumption

The power consumption is typically measured at Ta = 25 °C(VDDIO 3.3V).

Parameters	Conditions	Min.	Typ.	Max.	Unit
2.4 GHz, Rx 11n Active	MCS7 @ -70 dBm		190		mW
2.4 GHz, Rx 11n Active	MCS7 @ -70 dBm		210		
2.4 GHz, Tx 11b, CCK	19.5 dBm @ EVM = -9 dB		990		
2.4 GHz, Tx 11n, MCS7	15.5 dBm @ EVM = -28 d		750		
5 GHz, Tx 11n, MCS7	13.5 dBm @ EVM = -28 dB		900		

11. Pin Assignment (Top View, Bottom Layer)

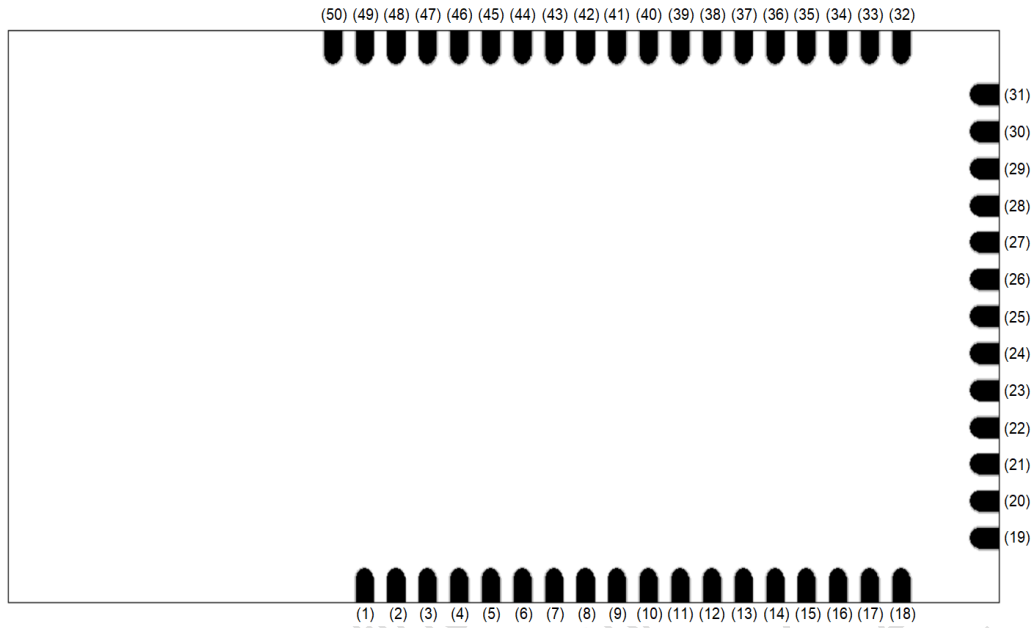

No.	Pin Name	No.	Pin Name	No.	Pin Name
1	GND	18	GND	35	RST
2	GND	19	VDD_SYS	36	GP22
3	GND	20	GND	37	VDD_RF
4	VDD_3.3V	21	UART_RXD0	38	GND
5	GND	22	UART_TXD0	39	GADC2
6	VDD_IO_1	23	SF_SIO0	40	GADC1
7	SD_D2	24	SF_SCLK	41	GADC0
8	SD_D3	25	GP00	42	GND
9	SD_CMD	26	GP01	43	VDD_3.3V
10	SD_CLK	27	GP02	44	GP05
11	SD_D0	28	GP03	45	GP04
12	SD_D1	29	SF_CSN	46	GP21
13	GND	30	VDD_MEM	47	GND
14	GP18	31	SF_SIO1	48	GND
15	GP23	32	GND	49	GND
16	GP24	33	VDD_IO_2	50	GND
17	PMIC_EN	34	GP25		

12. Pin Description

Pin No.	Pin Name	Description
1	GND	Module Ground
2	GND	
3	GND	
4	VDD_3.3V	2.4G PA supply voltage (3.3V DC)
5	GND	Module Ground
6	VDD_IO_1	IO Supply Voltage
7	SD_D2	SDIO Data 2 / I2C Data / GPIO14/ IR RX Input
8	SD_D3	SDIO Data 3 or SDIO SPI Mode CS or SPI CS / GPIO15
9	SD_CMD	SD CMD or SDIO SPI Mode DI or SPI DI / GPIO10
10	SD_CLK	SDIO Clock (33Ω series connect*) or SDIO SPI Mode CLK or SPI Clock / GPIO11
11	SD_D0	SD Data 0 or SDIO SPI Mode DO or SPI DO/ GPIO12
12	SD_D1	SD Data 1 or SDIO SPI Mode IRQ / IR TX Output / I2C Clock / GPIO13
13	GND	Module Ground
14	GP18	GPIO18
15	GP23	IR TX Output / GPIO23
16	GP24	IR RX input / GPIO24
17	PMIC_EN	INTERNAL PMIC PWR EN
18	GND	Module Ground
19	VDD_SYS	INTERNAL DCDC analog supply input
20	GND	Module Ground
21	UART_RXD0	Debug UART0 RXD / I2C Clock / GPIO8
22	UART_TXD0	Debug UART0 TXD / I2C Data / GPIO9
23	SF_SIO0	Not connected (Internal SF_SIO0)
24	SF_SCLK	Not connected (Internal SF_SCLK)
25	GP00	UART RX Input for UART 1 / I2S LRCK / GPIO 0
26	GP01	UART TX Output for UART 1 / I2S BCK /GPIO1
27	GP02	UART RX Input for UART2 / I2S Data Out for I2S Master / I2S Data In for I2S Slave
28	GP03	UART TX Output for UART 2 / I2S Master Clock / GPIO3
29	SF_CSN	Not connected (Internal SF_CSN)
30	VDD_MEM	Internal Flash Memory Power input
31	SF_SIO1	Not connected (Internal SF_SIO1)
32	GND	Module Ground
33	VDD_IO_2	IO Supply Voltage
34	GP25	RESET Select("H" : External Reset, "L" : Internal POR) / GPIO25
35	RST	Reset (Active Low)
36	GP22	Boot Select(External PU : SF Boot, PD : ROM Boot) / GPIO22
37	VDD_RF	Wi-Fi PLL Analog Supply Voltage(3.3V DC)
38	GND	Module Ground
39	GADC2	ADC INPUT
40	GADC1	ADC INPUT
41	GADC0	ADC INPUT
42	GND	Module Ground
43	VDD_3.3V	5G PA supply voltage (3.3V DC)
44	GP05	UART RX Input for UART1/ SPI DI / GPIO5
45	GP04	UART TX Output for UART1/ SPI DO / GPIO4
46	GP21	I2S SDO1 for Master or Slave / I2S SDI1 for Master or Slave / GPIO21
47	GND	Module Ground
48	GND	
49	GND	
50	GND	

13. Block Diagram

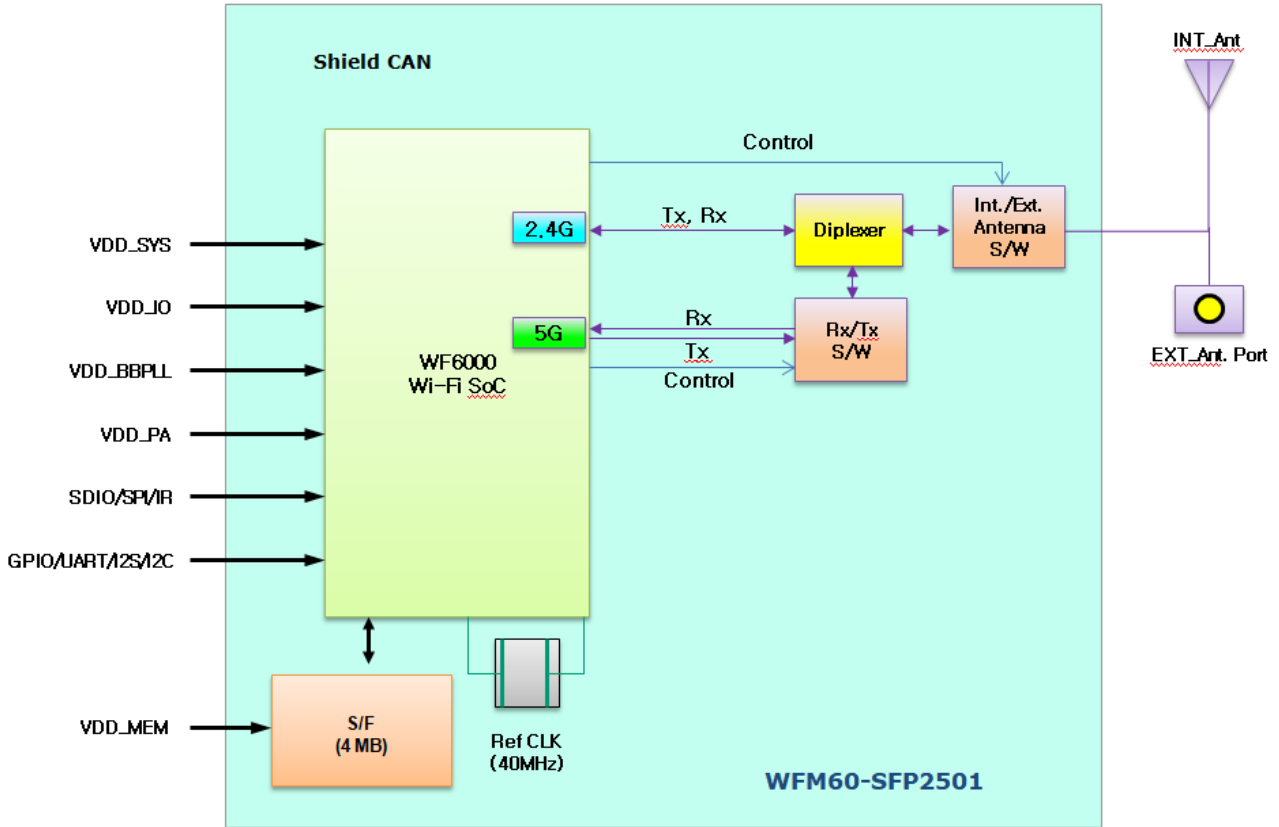
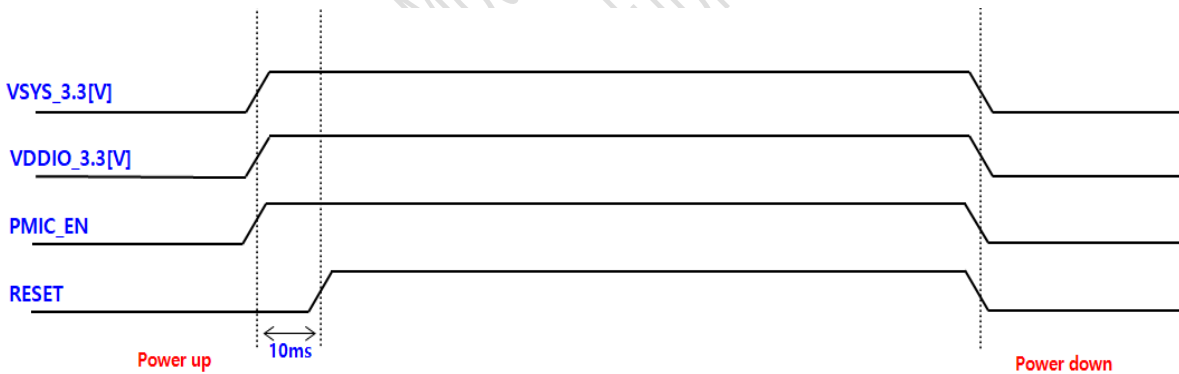

Figure 3. Block Diagram

14. Power Sequence



※ When VCC is below 3.0V, it must be reset.

15. Packing Information

15.1 Carrier dimension

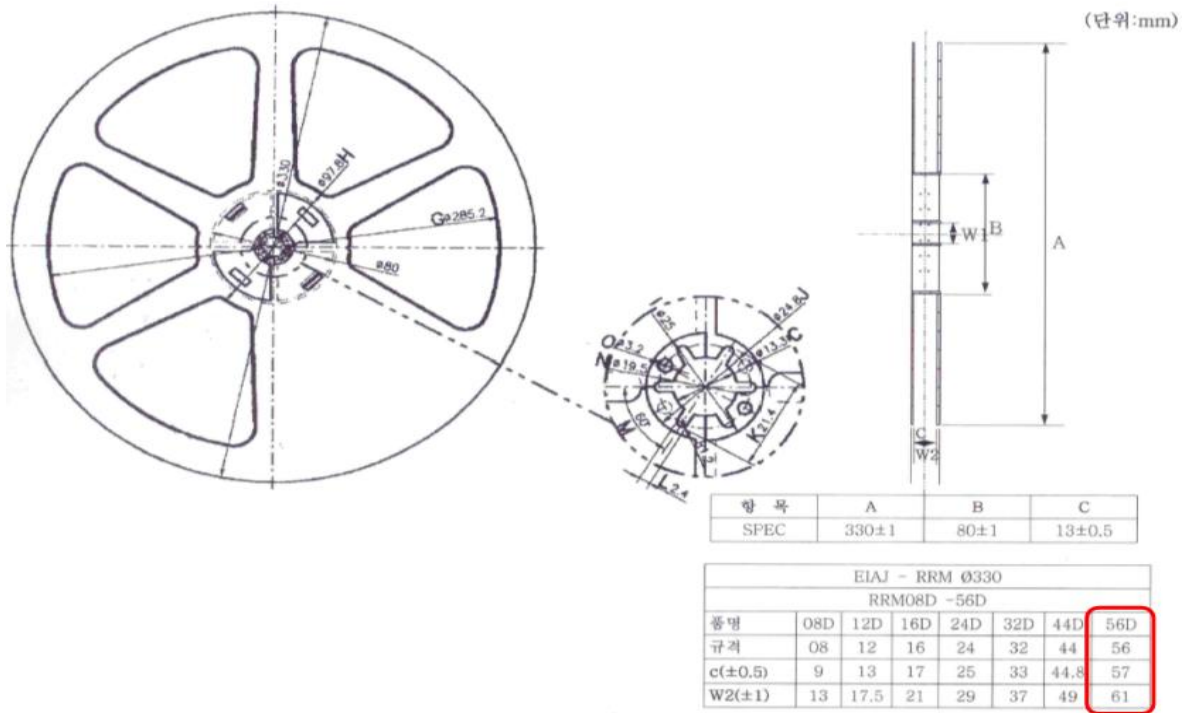

15.2 Carrier tape dimension

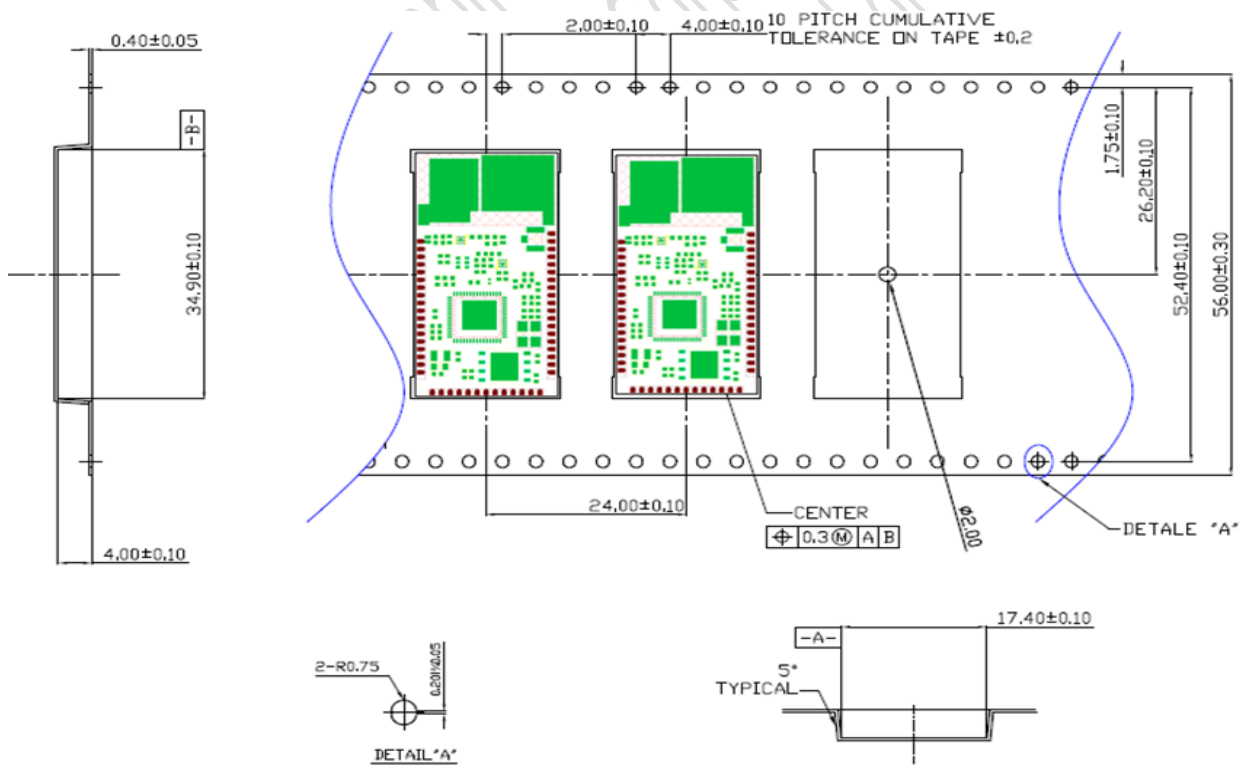

16. Reflow Profile

- Refer to the IPC/JEDEC standard.
- Peak Temperature : <250°C>
- Number of Times : ≤2 times

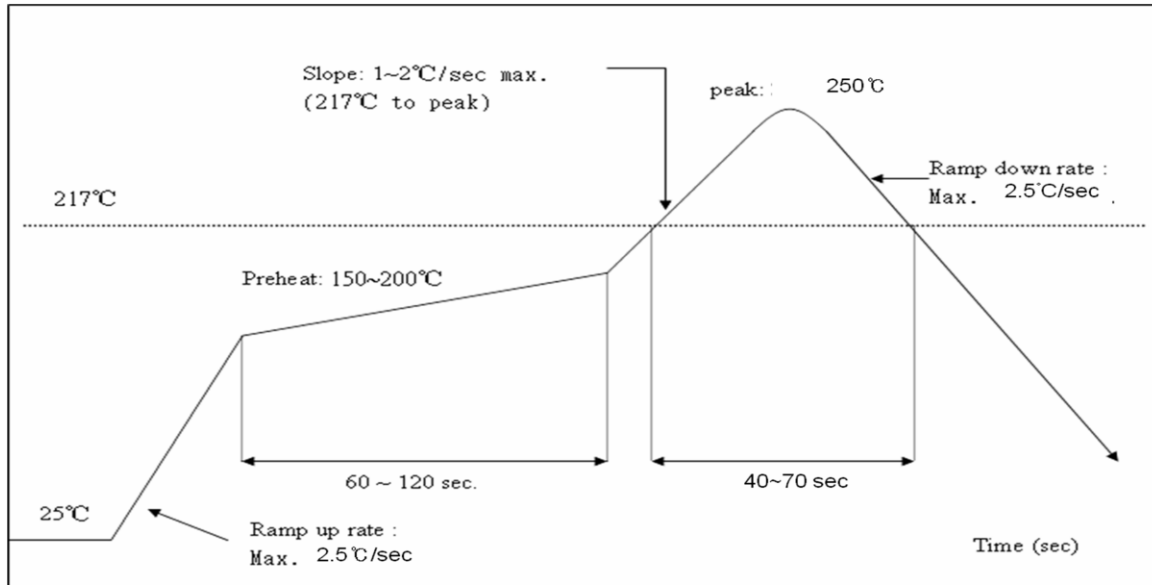

17. Revision History

Ver.	Comment	Date	Author	Approver
0.1	Initial release	Mar, 28, 2018	M.H.LEE	
0.2	RF 성능 Up-date 및 Packing data 추가	July, 20, 2018	M.H.LEE	
0.3	Pin Description 및 Packing 사양 변경	August,9,2018	M.H.LEE	

The module is labeled with its own FCC ID and IC Certification Number. If the FCC ID and IC Certification Number are not visible when the module is installed inside another device, then the outside of the device into which the module is installed must also display a label referring to the enclosed module. In that case, the final end product must be labeled in a visible area with the following:

"Contains FCC ID: 2ADXS-WFM60-SFP2501"

"Contains IC: 12641A-WFM6SFP2501"

Le module BT111 est étiqueté avec sa propre identification FCC et son propre numéro de certification IC. Si l'identification FCC et le numéro de certification IC ne sont pas visibles lorsque le module est installé à l'intérieur d'un autre dispositif, la partie externe du dispositif dans lequel le module est installé devra également présenter une étiquette faisant référence au module inclus. Dans ce cas, le produit final devra être étiqueté sur une zone visible avec les informations suivantes :

« Contient module émetteur identification FCC ID : 2ADXS-WFM60-SFP2501

« Contient module émetteur IC : 12641A-WFM6SFP2501"

18. FCC/ISED Statement

This device complies with part 15 of the FCC Rules. Operation is subject to the following two conditions:

- (1) This device may not cause harmful interference, and
- (2) this device must accept any interference received, including interference that may cause undesired operation.

Any changes or modifications not expressly approved by the party responsible for compliance could void the user's authority to operate this equipment.

The antenna(s) must be installed such that a minimum separation distance of at least 20 cm is maintained between the radiator (antenna) and all persons at all times. This device must not be co-located or operating in conjunction with any other antenna or transmitter.

This equipment has been tested and found to comply with the limits for a Class B digital device, pursuant to part 15 of the FCC Rules.

These limits are designed to provide reasonable protection against harmful interference in a residential installation. This equipment generates, uses and can radiate radio frequency energy and, if not installed and used in accordance with the instructions, may cause harmful interference to radio communications. However, there is no guarantee that interference will not occur in a particular installation. If this equipment does cause harmful interference to radio or television reception, which can be determined by turning the equipment off and on, the user is encouraged to try to correct the interference by one or more of the following measures:

- Reorient or relocate the receiving antenna.
- Increase the separation between the equipment and receiver.
- Connect the equipment into an outlet on a circuit different from that to which the receiver is connected.
- Consult the dealer or an experienced radio/TV technician for help.

l'exposition aux RF

L'antenne (ou les antennes) doit être installée de façon à maintenir à tout instant une distance minimum de au moins 20 cm entre la source de radiation (l'antenne) et toute personne physique.

Le présent appareil est conforme aux CNR d'Industrie Canada applicables aux appareils radio exempts de licence. L'exploitation est autorisée aux deux conditions suivantes :

- (1) l'appareil ne doit pas produire de brouillage, et
- (2) l'utilisateur de l'appareil doit accepter tout brouillage radioélectrique subi, même si le brouillage est susceptible d'en compromettre le fonctionnement.

This radio transmitter [12641A-WFM6SFP2501] has been approved by Innovation, Science and Economic Development Canada to operate with the antenna types listed below, with the maximum permissible gain indicated. Antenna types not included in this list that have a gain greater than the maximum gain indicated for any type listed are strictly prohibited for use with this device.

Le présent émetteur radio [12641A-WFM6SFP2501] a été approuvé par Innovation, Sciences et Développement économique Canada pour fonctionner avec les types d'antenne énumérés ci-dessous et ayant un gain admissible maximal. Les types d'antenne non inclus dans cette liste, et dont le gain est supérieur au gain maximal indiqué pour tout type figurant sur la liste, sont strictement interdits pour l'exploitation de l'émetteur.