

## 11 SAR TEST RESULTS

### Test Condition:

1.	SAR Measurement The distance between the EUT and the antenna of the emulator is more than 50 cm and the output power radiated from the emulator antenna is at least 30 dB less than the output power of EUT.		
2	Measurement Uncertainty: See page 34 for detail		
3	Environmental Conditions	Temperature	23°C
		Relative Humidity	53%
		Atmospheric Pressure	1019mbar
4	Test Date : December 10th,2015, 2015~ December 24th,2015 Tested By : Wiky Jam		

### Generally Test Procedures:

1. Establish communication link between EUT and base station emulation by air link.
2. Place the EUT in the selected test position. (Cheek, tilt or flat)
3. Perform SAR testing at middle or highest output power channel under the selected test mode. If the measured 1-g SAR is  $\leq 0.8$  W/kg, then testing for the other channel will not be performed.
4. When SAR is  $< 0.8$  W/kg, no repeated SAR measurement is required

### For WCDMA test:

1. KDB941225 D01-Body SAR is not required for HSDPA when the average output of each RF channel with HSDPA active is less than 0.25dB higher than measured without HSDPA using 12.2kbps RMC or the maximum SAR for 12.2kbps RMC  $< 75\%$  of the SAR limit.
2. KDB941225 D01-Body SAR is not required for handset with HSPA capabilities when the maximum average output of each RF channel with HSUPA/HSDPA active is less than 0.25dB higher than that measure without HSUPA/HSDPA using 12.2kbps RMC AND THE maximum SAR for 12.2kbps RMC is  $< 75\%$  of the SAR limit

### For LTE test:

1. According to FCC KDB 941225 D05v02r01:
  - a. Per Section 5.2.1, SAR is required for QPSK 1 RB Allocation for the largest bandwidth
    - i. The required channel and offset combination with the highest maximum output power is required for SAR.
    - ii. When the reported SAR is  $\leq 0.8$  W/kg, testing of the remaining RB offset configurations and required test channels is not required. Otherwise, SAR is required for the remaining required test channels using the RB offset configuration with highest output power for that channel.
    - iii. When the reported SAR for a required test channel is  $> 1.45$  W/kg, SAR is required for all RB offset configurations for that channel.
  - b. Per Section 5.2.2, SAR is required for 50% RB allocation using the largest bandwidth following the same procedures outlined in Section 5.2.1.
  - c. Per Section 5.2.3, QPSK SAR is not required for the 100% allocation when the highest maximum output power for the 100% allocation is less than the highest maximum output power of the 1 RB and 50% RB allocations and the reported SAR for the 1 RB and 50% RB allocations is  $< 0.8$  W/kg.
  - d. Per Section 5.2.4 and 5.3, SAR tests for higher order modulations and lower bandwidths configurations are not required when the conducted power of the required test configurations determined by Sections 5.2.1 through 5.2.3 is less than or equal to  $\frac{1}{2}$  dB higher than the equivalent configuration using QPSK modulation and when the QPSK SAR for those configurations is  $< 1.45$  W/kg.

### SAR Summary Test Result:

#### GSM850

Date of Measured : December 14th,2015			Body-worn/Hotspot Separation Distance:1.0cm					
Position	Channel	Mode	SAR 1g(W/kg)	Limit (W/kg)	Power Drift (%)	Maximum Turn-up Power(dBm)	measured output power (dBm)	Scaled Maximum SAR(W/kg)
Right Head Cheek	Mid	GSM voice	0.200	1.6	0.23	33.5	32.86	0.23
Right Head Tilt	Mid	GSM voice	0.181	1.6	-0.13	33.5	32.86	0.21
Left Head Cheek	Mid	GSM voice	0.199	1.6	-1.93	33.5	32.86	0.23
Left Head Tilt	Mid	GSM voice	0.174	1.6	0.33	33.5	32.86	0.20
Body Front side	Mid	GPRS Class12	0.694	1.6	3.11	30	29.44	0.79
Body Back-side	Low	GPRS Class12	1.051	1.6	0.96	30	29.47	1.19
Body Back-side	Mid	GPRS Class12	1.076	1.6	-1.28	30	29.44	1.22
Body Back-side	Mid	GPRS Class12	1.079	1.6	0.22	30	29.44	1.23
Body Back-side	High	GPRS Class12	1.068	1.6	1.88	30	29.39	1.23
Body Right EDGE	Mid	GPRS Class12	0.296	1.6	1.62	30	29.44	0.34
Body Bottom EDGE	Mid	GPRS Class12	0.246	1.6	0.69	30	29.44	0.28

#### WCDMA BAND V (850)

Date of Measured : December 15th,2015			Body-worn/Hotspot Separation Distance:1.0cm					
Position	Channel	Mode	SAR 1g(W/kg)	Limit (W/kg)	Power Drift (%)	Maximum Turn-up Power(dBm)	measured output power (dBm)	Scaled Maximum SAR(W/kg)
Right Head Cheek	Mid	RMC 12.2kbps	0.171	1.6	0.25	23	22.17	0.21
Right Head Tilt	Mid	RMC 12.2kbps	0.102	1.6	-1.65	23	22.17	0.12
Left Head Cheek	Mid	RMC 12.2kbps	0.156	1.6	3.74	23	22.17	0.19
Left Head Tilt	Mid	RMC 12.2kbps	0.121	1.6	-0.15	23	22.17	0.15
Body Front side	Mid	RMC 12.2kbps	0.254	1.6	0.97	23	22.17	0.31
Body Back-side	Mid	RMC 12.2kbps	0.386	1.6	-0.06	23	22.17	0.47
Body Right EDGE	Mid	RMC 12.2kbps	0.209	1.6	-2.02	23	22.17	0.25
Body Bottom EDGE	Mid	RMC 12.2kbps	0.217	1.6	1.17	23	22.17	0.26

**PCS1900:**

Date of Measured : December 21th,2015			Body-worn/Hotspot Separation Distance:1.0cm					
Position	Channel	Mode	SAR 1g(W/kg)	Limit (W/kg)	Power Drift (%)	Maximum Turn-up Power(dBm)	measured output power (dBm)	Scaled Maximum SAR(W/kg)
Right Head Cheek	Mid	GSM voice	0.069	1.6	1.30	31	29.81	0.09
Right Head Tilt	Mid	GSM voice	0.064	1.6	1.51	31	29.81	0.08
Left Head Cheek	Mid	GSM voice	0.071	1.6	3.34	31	29.81	0.09
Left Head Tilt	Mid	GSM voice	0.063	1.6	-2.58	31	29.81	0.08
Body Front side	Mid	GPRS Class12	0.519	1.6	2.01	28	26.89	0.67
Body Back side	Mid	GPRS Class12	0.728	1.6	-0.84	28	26.89	0.94
Body Right EDGE	Mid	GPRS Class12	0.286	1.6	0.25	28	26.89	0.37
Body Bottom EDGE	Mid	GPRS Class12	0.265	1.6	0.02	28	26.89	0.34

**WCDMA BAND II (1900):**

Date of Measured : December 22th,2015			Body-worn/Hotspot Separation Distance:1.0cm					
Position	Channel	Mode	SAR 1g(W/kg)	Limit (W/kg)	Power Drift (%)	Maximum Turn-up Power(dBm)	measured output power (dBm)	Scaled Maximum SAR(W/kg)
Right Head Cheek	Mid	RMC 12.2kbps	0.173	1.6	-0.27	24	23.19	0.21
Right Head Tilt	Mid	RMC 12.2kbps	0.154	1.6	0.22	24	23.19	0.19
Left Head Cheek	Mid	RMC 12.2kbps	0.124	1.6	-3.39	24	23.19	0.15
Left Head Tilt	Mid	RMC 12.2kbps	0.119	1.6	0.07	24	23.19	0.14
Body Front side	Mid	RMC 12.2kbps	0.466	1.6	-0.36	24	23.19	0.56
Body Back-side	Mid	RMC 12.2kbps	0.724	1.6	0.48	24	23.19	0.87
Body Right EDGE	Mid	RMC 12.2kbps	0.231	1.6	-1.55	24	23.19	0.28
Body Bottom EDGE	Mid	RMC 12.2kbps	0.172	1.6	-2.41	24	23.19	0.21

**WCDMA BAND IV (1700):**

Date of Measured : December 17th,2015			Body-worn/Hotspot Separation Distance:1.0cm					
Position	Channel	Mode	SAR 1g(W/kg)	Limit (W/kg)	Power Drift (%)	Maximum Turn-up Power(dBm)	measured output power (dBm)	Scaled Maximum SAR(W/kg)
Right Head Cheek	Mid	RMC 12.2kbps	0.224	1.6	2.13	24	23.17	0.27
Right Head Tilt	Mid	RMC 12.2kbps	0.196	1.6	0.46	24	23.17	0.24
Left Head Cheek	Mid	RMC 12.2kbps	0.210	1.6	-1.89	24	23.17	0.25
Left Head Tilt	Mid	RMC 12.2kbps	0.163	1.6	-1.70	24	23.17	0.20
Body Front side	Mid	RMC 12.2kbps	0.621	1.6	-0.21	24	23.17	0.75
Body Back-side	Mid	RMC 12.2kbps	0.758	1.6	-1.32	24	23.17	0.92
Body Right EDGE	Mid	RMC 12.2kbps	0.482	1.6	0.08	24	23.17	0.58
Body Bottom EDGE	Mid	RMC 12.2kbps	0.347	1.6	20.31	24	23.17	0.42

**LTE Band 17 (700):**

Date of Measured : December 10th,2015						Body-worn/Hotspot Separation Distance:1.0cm				
Position	Channel	Bandwidth (MHz)	MPR (dB)	RB Size	RB Offset	SAR 1g(W/kg)	Power Drift (%)	Maximum Turn-up Power (dBm)	measured output power (dBm)	Scaled Maximum SAR(W/kg)
Right Head Cheek	Mid	10	0	1	24	0.105	-1.61	24	23.15	0.13
Right Head Cheek	Mid	10	1	25	12	0.086	4.91	24	22.14	0.13
Right Head Tilt	Mid	10	0	1	24	0.101	-3.02	24	23.15	0.12
Right Head Tilt	Mid	10	1	25	12	0.072	-3.47	24	22.14	0.11
Left Head Cheek	Mid	10	0	1	24	0.067	1.96	24	23.15	0.08
Left Head Cheek	Mid	10	1	25	12	0.075	2.17	24	22.14	0.12
Left Head Tilt	Mid	10	0	1	24	0.080	-0.96	24	23.15	0.10
Left Head Tilt	Mid	10	1	25	12	0.091	-0.84	24	22.14	0.14
Body-worn LCD up	Mid	10	0	1	24	0.214	-3.35	24	23.15	0.26
Body-worn LCD up	Mid	10	1	25	12	0.205	1.07	24	22.14	0.31
Body-worn LCD Down	Mid	10	0	1	24	0.391	3.13	24	23.15	0.48
Body-worn LCD Down	Mid	10	1	25	12	0.313	1.26	24	22.14	0.48
Body Right EDGE	Mid	10	0	1	24	0.207	3.18	24	23.15	0.25
Body Right EDGE	Mid	10	1	25	12	0.114	-2.24	24	22.14	0.17
Body Bottom EDGE	Mid	10	0	1	24	0.121	0.71	24	23.15	0.15
Body Bottom EDGE	Mid	10	1	25	12	0.108	-1.96	24	22.14	0.17
Modulation: QPSK						Limit: 1.6W/kg averaged over 1gram				

**LTE Band 12 (700):**

Date of Measured : December 11th,2015						Body-worn/Hotspot Separation Distance:1.0cm				
Position	Channel	Bandwidth (MHz)	MPR (dB)	RB Size	RB Offset	SAR 1g(W/kg)	Power Drift (%)	Maximum Turn-up Power (dBm)	measured output power (dBm)	Scaled Maximum SAR(W/kg)
Right Head Cheek	Mid	10	0	1	24	0.107	-1.62	23.3	22.99	0.11
Right Head Cheek	Mid	10	1	25	12	0.082	1.14	23.3	21.97	0.11
Right Head Tilt	Mid	10	0	1	24	0.074	-0.40	23.3	22.99	0.08
Right Head Tilt	Mid	10	1	25	12	0.081	2.00	23.3	21.97	0.11
Left Head Cheek	Mid	10	0	1	24	0.114	-2.53	23.3	22.99	0.12
Left Head Cheek	Mid	10	1	25	12	0.105	-2.46	23.3	21.97	0.14
Left Head Tilt	Mid	10	0	1	24	0.057	1.97	23.3	22.99	0.06
Left Head Tilt	Mid	10	1	25	12	0.066	-2.35	23.3	21.97	0.09
Body-worn LCD up	Mid	10	0	1	24	0.229	-0.93	23.3	22.99	0.25
Body-worn LCD up	Mid	10	1	25	12	0.206	1.42	23.3	21.97	0.28
Body-worn LCD Down	Mid	10	0	1	24	0.316	-1.93	23.3	22.99	0.34
Body-worn LCD Down	Mid	10	1	25	12	0.387	-1.31	23.3	21.97	0.53
Body Right EDGE	Mid	10	0	1	24	0.246	-0.54	23.3	22.99	0.26
Body Right EDGE	Mid	10	1	25	12	0.251	-2.28	23.3	21.97	0.34
Body Bottom EDGE	Mid	10	0	1	24	0.156	-2.44	23.3	22.99	0.17
Body Bottom EDGE	Mid	10	1	25	12	0.088	0.14	23.3	21.97	0.12
Modulation: QPSK						Limit: 1.6W/kg averaged over 1gram				

**LTE Band 7 (2600):**

Date of Measured : December 23th,2015						Body-worn/Hotspot Separation Distance:1.0cm				
Position	Channel	Bandwidth (MHz)	MPR (dB)	RB Size	RB Offset	SAR 1g(W/kg)	Power Drift (%)	Maximum Turn-up Power (dBm)	measured output power (dBm)	Scaled Maximum SAR(W/kg)
Right Head Cheek	Mid	20	0	1	49	0.101	-0.58	24	23.28	0.12
Right Head Cheek	Mid	20	1	50	24	0.074	1.31	24	22.08	0.12
Right Head Tilt	Mid	20	0	1	49	0.062	-2.55	24	23.28	0.07
Right Head Tilt	Mid	20	1	50	24	0.056	-1.18	24	22.08	0.09
Left Head Cheek	Mid	20	0	1	49	0.100	0.07	24	23.28	0.12
Left Head Cheek	Mid	20	1	50	24	0.081	0.7	24	22.08	0.13
Left Head Tilt	Mid	20	0	1	49	0.077	0.87	24	23.28	0.09
Left Head Tilt	Mid	20	1	50	24	0.064	-2.33	24	22.08	0.10
Body-worn LCD up	Mid	20	0	1	49	0.203	0.74	24	23.28	0.24
Body-worn LCD up	Mid	20	1	50	24	0.151	0.96	24	22.08	0.23
Body-worn LCD Down	Mid	20	0	1	49	0.316	-1.62	24	23.28	0.37
Body-worn LCD Down	Mid	20	1	50	24	0.308	0.36	24	22.08	0.48
Body Right EDGE	Mid	20	0	1	49	0.177	-2.11	24	23.28	0.21
Body Right EDGE	Mid	20	1	50	24	0.115	1.64	24	22.08	0.18
Body Bottom EDGE	Mid	20	0	1	49	0.124	0.98	24	23.28	0.15
Body Bottom EDGE	Mid	20	1	50	24	0.188	2.69	24	22.08	0.29
Modulation: QPSK						Limit: 1.6W/kg averaged over 1gram				

**LTE Band 5 (850):**

Date of Measured : December 14th,2015						Body-worn/Hotspot Separation Distance:1.0cm				
Position	Channel	Bandwidth (MHz)	MPR (dB)	RB Size	RB Offset	SAR 1g(W/kg)	Power Drift (%)	Maximum Turn-up Power (dBm)	measured output power (dBm)	Scaled Maximum SAR(W/kg)
Right Head Cheek	Mid	10	0	1	24	0.109	1.04	23	22.94	0.11
Right Head Cheek	Mid	10	1	25	12	0.074	-1.56	23	21.95	0.09
Right Head Tilt	Mid	10	0	1	24	0.055	2.17	23	22.94	0.06
Right Head Tilt	Mid	10	1	25	12	0.084	-1.13	23	21.95	0.11
Left Head Cheek	Mid	10	0	1	24	0.104	-1.47	23	22.94	0.11
Left Head Cheek	Mid	10	1	25	12	0.076	1.88	23	21.95	0.10
Left Head Tilt	Mid	10	0	1	24	0.067	1.36	23	22.94	0.07
Left Head Tilt	Mid	10	1	25	12	0.070	-0.71	23	21.95	0.09
Body-worn LCD up	Mid	10	0	1	24	0.152	-1.91	23	22.94	0.15
Body-worn LCD up	Mid	10	1	25	12	0.211	2.14	23	21.95	0.27
Body-worn LCD Down	Mid	10	0	1	24	0.271	0.66	23	22.94	0.27
Body-worn LCD Down	Mid	10	1	25	12	0.317	-1.21	23	21.95	0.40
Body Right EDGE	Mid	10	0	1	24	0.121	-2.19	23	22.94	0.12
Body Right EDGE	Mid	10	1	25	12	0.140	-1.64	23	21.95	0.18
Body Bottom EDGE	Mid	10	0	1	24	0.179	0.65	23	22.94	0.18
Body Bottom EDGE	Mid	10	1	25	12	0.195	2.11	23	21.95	0.25
Modulation: QPSK						Limit: 1.6W/kg averaged over 1gram				



**LTE Band 4 (1700):**

Date of Measured : December 18th,2015						Body-worn/Hotspot Separation Distance:1.0cm				
Position	Channel	Bandwidth (MHz)	MPR (dB)	RB Size	RB Offset	SAR 1g(W/kg)	Power Drift (%)	Maximum Turn-up Power (dBm)	measured output power (dBm)	Scaled Maximum SAR(W/kg)
Right Head Cheek	Mid	20	0	1	50	0.091	1.81	23	21.95	0.12
Right Head Cheek	Mid	20	1	50	25	0.064	1.63	23	21.85	0.08
Right Head Tilt	Mid	20	0	1	50	0.066	-2.83	23	21.95	0.08
Right Head Tilt	Mid	20	1	50	25	0.052	-3.21	23	21.85	0.07
Left Head Cheek	Mid	20	0	1	50	0.095	-0.51	23	21.95	0.12
Left Head Cheek	Mid	20	1	50	25	0.079	0.96	23	21.85	0.10
Left Head Tilt	Mid	20	0	1	50	0.073	0.41	23	21.95	0.09
Left Head Tilt	Mid	20	1	50	25	0.057	1.46	23	21.85	0.07
Body-worn LCD up	Mid	20	0	1	50	0.165	-1.84	23	21.95	0.21
Body-worn LCD up	Mid	20	1	50	25	0.157	-1.7	23	21.85	0.20
Body-worn LCD Down	Mid	20	0	1	50	0.273	-0.52	23	21.95	0.35
Body-worn LCD Down	Mid	20	1	50	25	0.231	-0.22	23	21.85	0.30
Body Right EDGE	Mid	20	0	1	50	0.159	1.09	23	21.95	0.20
Body Right EDGE	Mid	20	1	50	25	0.136	-0.28	23	21.85	0.18
Body Bottom EDGE	Mid	20	0	1	50	0.105	0.64	23	21.95	0.13
Body Bottom EDGE	Mid	20	1	50	25	0.093	-1.05	23	21.85	0.12
Modulation: QPSK						Limit: 1.6W/kg averaged over 1gram				

**LTE Band 2 (1900):**

Date of Measured : December 22th,2015						Body-worn/Hotspot Separation Distance:1.0cm				
Position	Channel	Bandwidth (MHz)	MPR (dB)	RB Size	RB Offset	SAR 1g(W/kg)	Power Drift (%)	Maximum Turn-up Power (dBm)	measured output power (dBm)	Scaled Maximum SAR(W/kg)
Right Head Cheek	Mid	20	0	1	49	0.107	1.35	24	23.14	0.13
Right Head Cheek	Mid	20	1	50	24	0.095	-0.53	24	22.19	0.14
Right Head Tilt	Mid	20	0	1	49	0.078	-0.07	24	23.14	0.10
Right Head Tilt	Mid	20	1	50	24	0.068	-0.33	24	22.19	0.10
Left Head Cheek	Mid	20	0	1	49	0.105	1.50	24	23.14	0.13
Left Head Cheek	Mid	20	1	50	24	0.088	3.67	24	22.19	0.13
Left Head Tilt	Mid	20	0	1	49	0.075	-0.4	24	23.14	0.09
Left Head Tilt	Mid	20	1	50	24	0.071	-1.79	24	22.19	0.11
Body-worn LCD up	Mid	20	0	1	49	0.304	2.03	24	23.14	0.37
Body-worn LCD up	Mid	20	1	50	24	0.218	4.09	24	22.19	0.33
Body-worn LCD Down	Mid	20	0	1	49	0.307	-0.88	24	23.14	0.37
Body-worn LCD Down	Mid	20	1	50	24	0.215	-2.02	24	22.19	0.33
Body Right EDGE	Mid	20	0	1	49	0.172	-4.81	24	23.14	0.21
Body Right EDGE	Mid	20	1	50	24	0.117	-3.28	24	22.19	0.18
Body Bottom EDGE	Mid	20	0	1	49	0.106	0.21	24	23.14	0.13
Body Bottom EDGE	Mid	20	1	50	24	0.114	1.72	24	22.19	0.17
Modulation: QPSK						Limit: 1.6W/kg averaged over 1gram				

### Measurement variability consideration

According to KDB 865664 D01v01 section 2.8.1, repeated measurements are required following the procedures as below:

1. Repeated measurement is not required when the original highest measured SAR is  $< 0.80\text{W/kg}$ ; steps 2) through 4) do not apply.
2. When the original highest measured SAR is  $\geq 0.80\text{ W/kg}$ , repeat that measurement once.
3. Perform a second repeated measurement only if the ratio of largest to smallest SAR for the original and first repeated measurements is  $> 1.20$  or when the original or repeated measurement is  $\geq 1.45\text{ W/kg}$  (~ 10% from the 1-g SAR limit).
4. Perform a third repeated measurement only if the original, first or second repeated measurement is  $\geq 1.5\text{ W/kg}$  and the ratio of largest to smallest SAR for the original, first and second repeated measurements is  $> 1.20$ .  
Measured SAR (W/Kg)

### Repeated SAR:

Band	Position	Channel	Mode	measured SAR( W/kg)				
				Original	1st Repeated		2nd Repeated	
					Value	Ratio	Value	Ratio
GSM850	Body Back-side	Middle	GPRS Class12	1.076	1.079	1.00	NA	NA

### Simultaneous Transmission SAR Analysis.

No.	Applicable Simultaneous Transmission Combination
1.	WWAN+BT
2.	WWAN+WIFI

Note:

1. For simultaneous transmission analysis, WiFi and Bluetooth SAR is estimated per KDB 447498 D01 v06 base on the formula below:
  - $(\text{max. power of channel, including tune-up tolerance, mW}) / (\text{min. test separation distance, mm}) \cdot [\sqrt{f_{\text{(GHz)}}/x}] \text{ W/kg}$  for test separation distances  $\leq 50\text{ mm}$ ;  
where  $x = 7.5$  for 1-g SAR, and  $x = 18.75$  for 10-g SAR.
  - $0.4\text{ W/kg}$  for 1-g SAR and  $1.0\text{ W/kg}$  for 10-g SAR, when the test separation distances is  $> 50\text{ mm}$ .<sup>21</sup>
2. If the test separation distances is  $\leq 5\text{mm}$ , 5mm is used for estimated SAR calculation.
3. WIFI maximum tune up power is 9dBm, BT's maximum tune up power is 4dBm and the estimated SAR is listed below.

Test position	Head(0.5cm)	Body-worn(1.0cm)
WIFI Estimated SAR(W/kg)	0.38	0.19
BT Estimated SAR(W/kg)	0.26	0.13

### Maximum Summation:

position	WWAN	WIFI	BT	WWAN+WIFI	WWAN+BT
	Max. Scaled SAR	Max. Scaled SAR	Max. Scaled SAR		
Head 0.5cm	0.27	0.38	0.26	0.65	0.53
Body 1.0cm	1.23	0.19	0.13	1.42	0.32

Note: 1g-SAR scalar summation  $< 1.6\text{W/kg}$ , so no simultaneous SAR is required.

## 12 SAR MEASUREMENT REFERENCES

### References

1. FCC 47 CFR Part 2 “Frequency Allocations and Radio Treaty Matters; General Rules and Regulations”
2. IEEE Std. C95.1-1999, “IEEE Standard for Safety Levels with Respect to Human Exposure to Radio Frequency Electromagnetic Fields, 3kHz to 300GHz”, 1999
3. IEEE Std. 1528-2013, “IEEE Recommended Practice for Determining the Peak Spatial-Average Specific Absorption Rate (SAR) in the Human Head from Wireless Communications Devices: Measurement Techniques”, June 2013
4. IEC 62209-2, “Human exposure to radio frequency fields from hand-held and body-mounted wireless communication devices—Human models, instrumentation, and procedures – Part 2: Procedure to determine the specific absorption rate(SAR) for wireless communication devices used in close proximity to the human body(frequency range of 30MHz to 6GHz)”, March 2010
5. FCC KDB 447498 D01 v06, “RF Exposure Procedures and Equipment Authorization Policies For Mobile and Portable Device”, October 23, 2015
6. FCC KDB 941225 D01 v03r01, “3G SAR Measurement Procedures”, October 23, 2015
7. FCC KDB 865664 D01 v01r04, “SAR Measurement Requirements For 100MHz to 6GHz”, August 7, 2015
8. FCC KDB648474 D04 v01r03, “SAR Evaluation Considerations for Wireless Handsets”. October 23, 2015
9. FCC KDB 941225 D05 v02r04, “SAR Evaluation Considerations for LTE Devices”, October 23, 2015
10. FCC KDB 941225 D06 v02r01, Hot Spot SAR ,October 23, 2015

### Maximum SAR measurement Plots

Test mode: GSM850, Middle channel (Right Head Cheek)

Product Description: Mobile Phone

Model: F55L

Test Date: December 14th, 2015

Medium(liquid type)	HSL_835
Frequency (MHz)	836.6000
Relative permittivity (real part)	41.2
Conductivity (S/m)	0.91
E-Field Probe	SN 27/15 EPGO262
Crest factor	8.0
Conversion Factor	1.90
Sensor-Surface	4mm
Area Scan	dx=8mm dy=8mm
Zoom Scan	5x5x7,dx=8mm dy=8mm dz=5mm
Variation (%)	0.360000
SAR 10g (W/Kg)	0.119193
SAR 1g (W/Kg)	0.200332
<b>SURFACE SAR</b>	<b>VOLUME SAR</b>

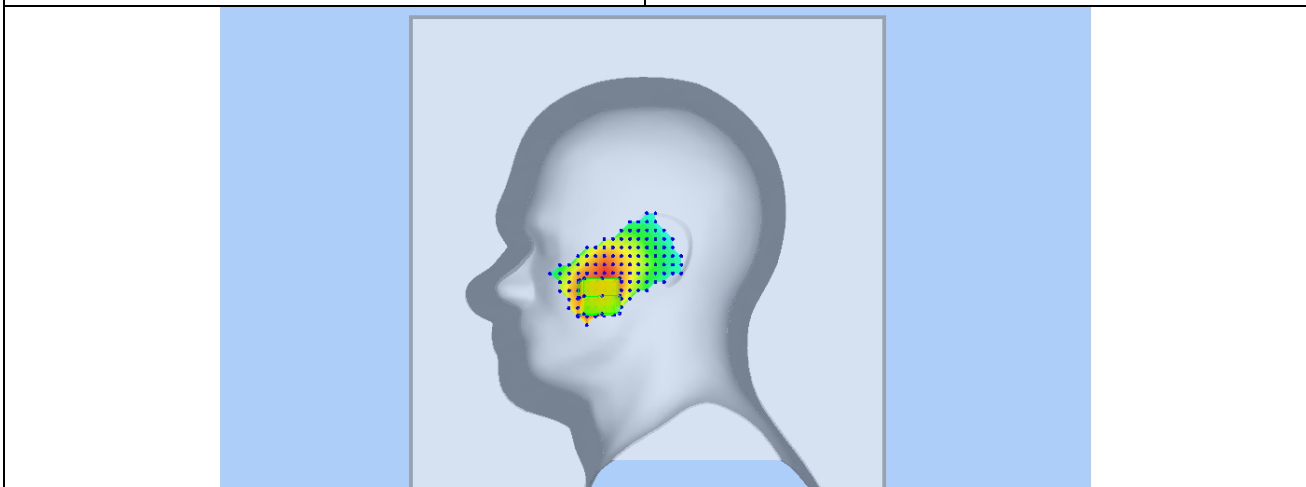
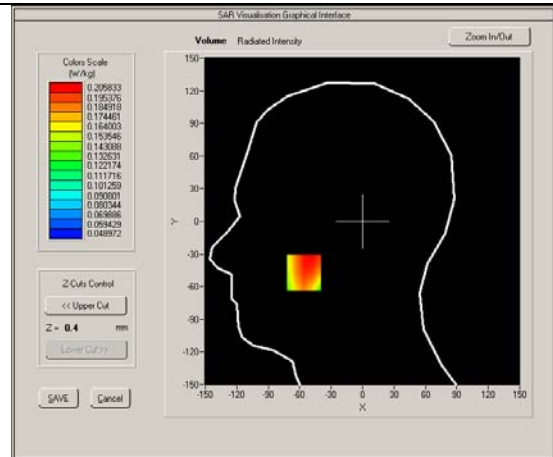
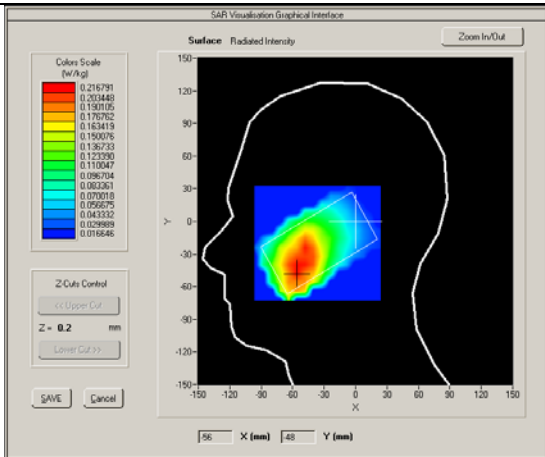

Test mode: GPRS850, Middle channel (Body Back Side)

Product Description: Mobile Phone

Model: F55L

Test Date: December 15th, 2015

Medium(liquid type)	MSL_835
Frequency (MHz)	836.6000
Relative permittivity (real part)	55.17
Conductivity (S/m)	0.99
E-Field Probe	SN 27/15 EPGO262
Crest factor	2.0
Conversion Factor	1.97
Sensor-Surface	4mm
Area Scan	dx=8mm dy=8mm
Zoom Scan	5x5x7, dx=8mm dy=8mm dz=5mm
Variation (%)	0.220000
SAR 10g (W/Kg)	0.586330
SAR 1g (W/Kg)	1.079441

**SURFACE SAR**

**VOLUME SAR**

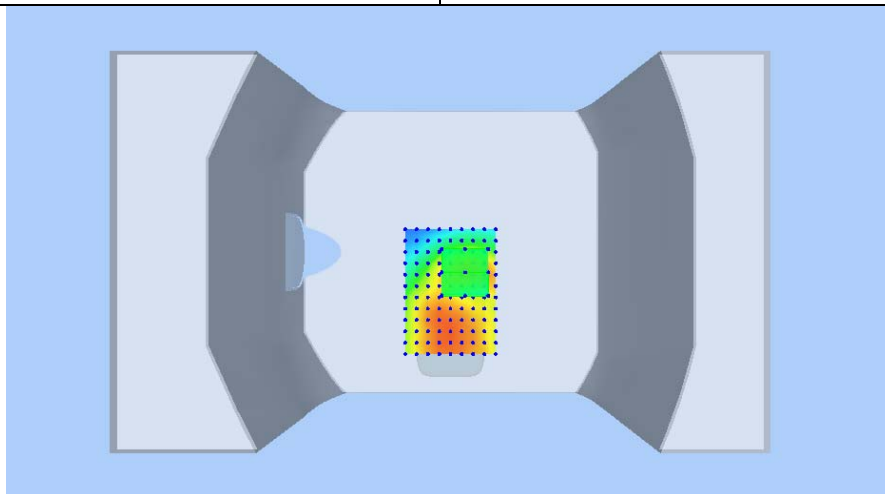
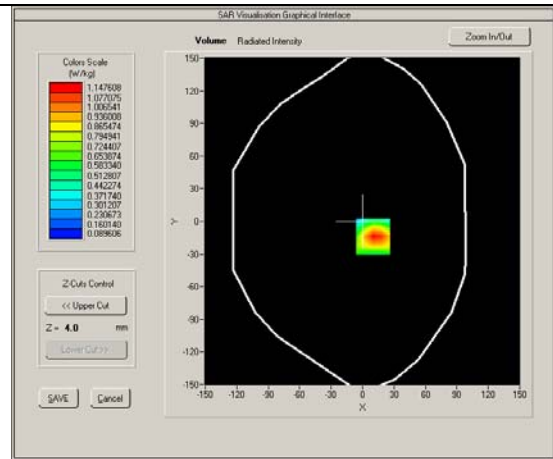
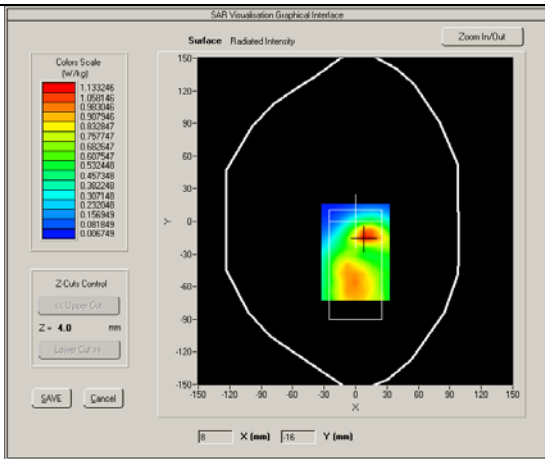

Test mode: WCDMA Band V, Middle channel (Right Head Cheek)

Product Description: Mobile Phone

Model: F55L

Test Date: December 14th, 2015

Medium(liquid type)	HSL_835
Frequency (MHz)	836.600
Relative permittivity (real part)	41.2
Conductivity (S/m)	0.91
E-Field Probe	SN 27/15 EPGO262
Crest factor	1.0
Conversion Factor	1.90
Sensor-Surface	4mm
Area Scan	dx=8mm dy=8mm
Zoom Scan	5x5x7, dx=8mm dy=8mm dz=5mm
Variation (%)	0.250000
SAR 10g (W/Kg)	0.091925
SAR 1g (W/Kg)	0.171258

**SURFACE SAR**

**VOLUME SAR**

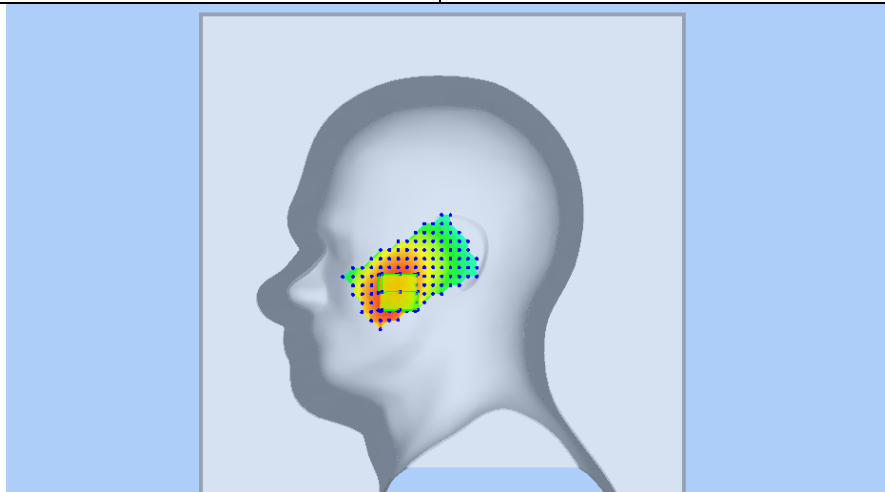
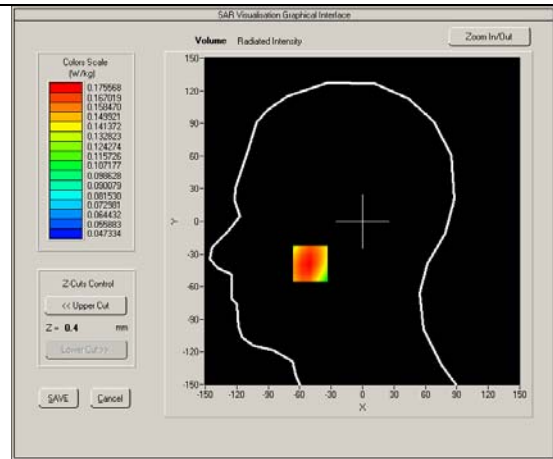
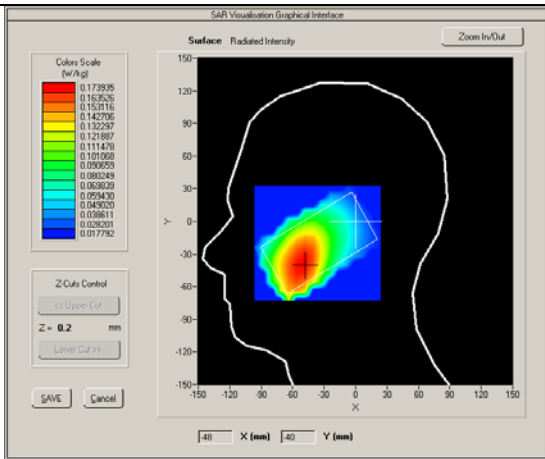

Test mode: WCDMA Band V, Middle channel (Body Back Side)

Product Description: Mobile Phone

Model: F55L

Test Date: December 15th, 2015

Medium(liquid type)	MSL_835
Frequency (MHz)	835.0000
Relative permittivity (real part)	55.17
Conductivity (S/m)	0.99
E-Field Probe	SN 27/15 EPGO262
Crest factor	1.0
Conversion Factor	1.97
Sensor-Surface	4mm
Area Scan	dx=8mm dy=8mm
Zoom Scan	5x5x7, dx=8mm dy=8mm dz=5mm
Variation (%)	-0.060000
SAR 10g (W/Kg)	0.129379
SAR 1g (W/Kg)	0.386033

**SURFACE SAR**

**VOLUME SAR**

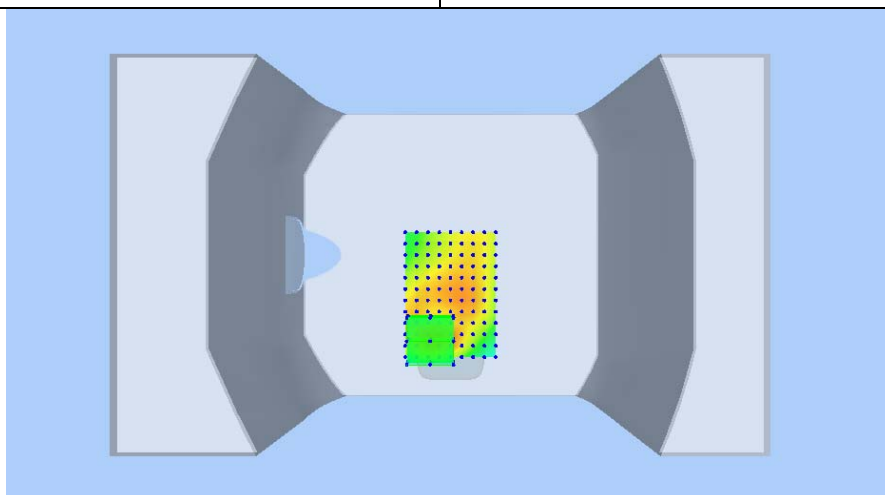
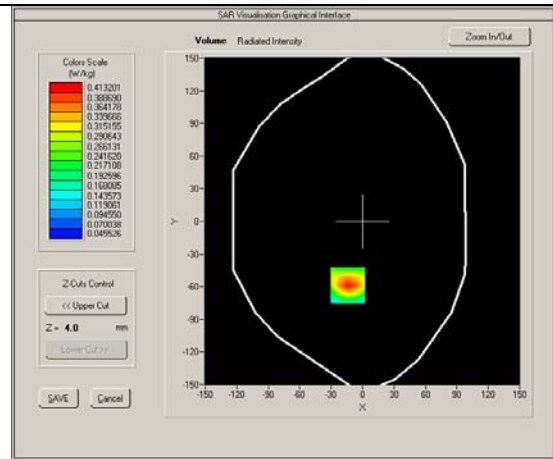
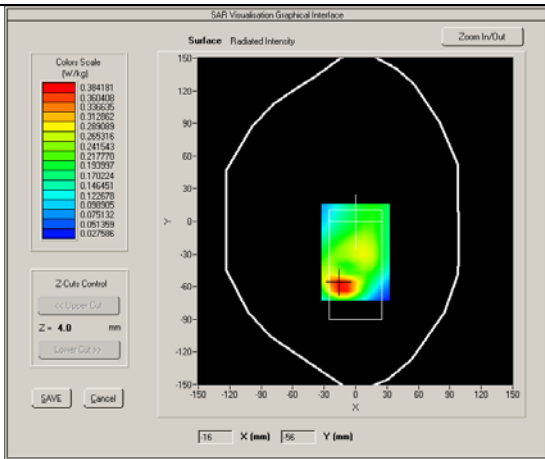



Test mode: PCS1900, Middle channel (Left Head Cheek)  
 Product Description: Mobile Phone  
 Model: F55L  
 Test Date: December 21th, 2015

Medium(liquid type)	HSL_1900
Frequency (MHz)	1880.000
Relative permittivity (real part)	40.02
Conductivity (S/m)	1.37
E-Field Probe	SN 27/15 EPGO262
Crest factor	8.0
Conversion Factor	2.26
Sensor-Surface	4mm
Area Scan	dx=8mm dy=8mm
Zoom Scan	5x5x7,dx=8mm dy=8mm dz=5mm
Variation (%)	3.340000
SAR 10g (W/Kg)	0.054271
SAR 1g (W/Kg)	0.073114

**SURFACE SAR**

**VOLUME SAR**

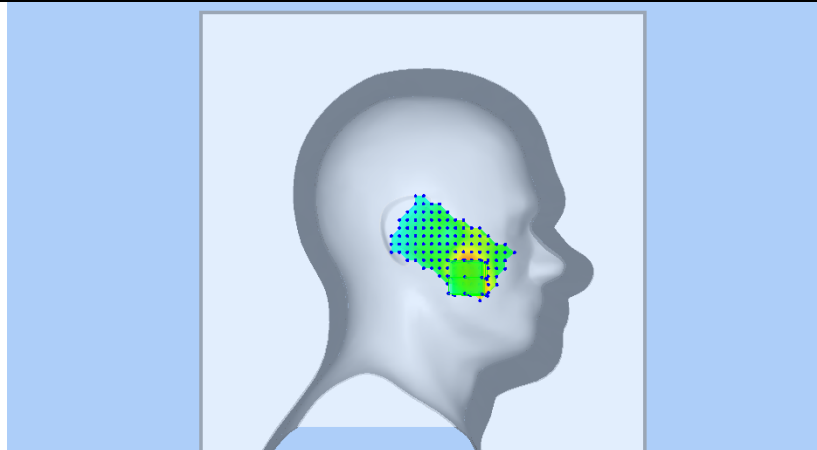
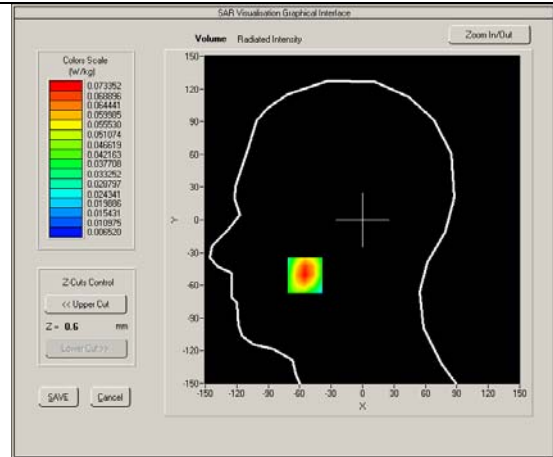
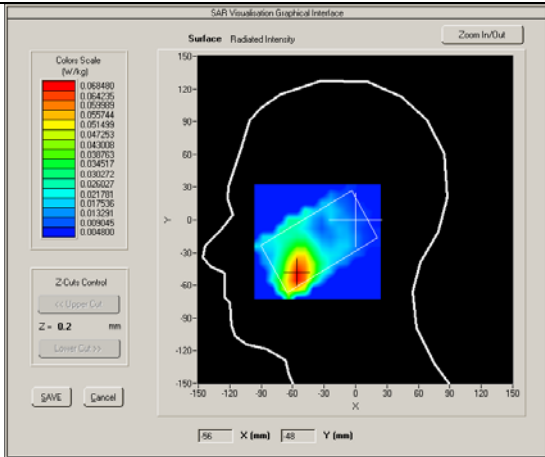

Test mode: GPRS1900, Middle channel (Body Back Side)  
 Product Description: Mobile Phone  
 Model: F55L  
 Test Date: December 22th, 2015

Medium(liquid type)	MSL_1900
Frequency (MHz)	1850.200
Relative permittivity (real part)	53.29
Conductivity (S/m)	1.51
E-Field Probe	SN 27/15 EPGO262
Crest factor	2.0
Conversion Factor	2.32
Sensor-Surface	4mm
Area Scan	dx=8mm dy=8mm
Zoom Scan	5x5x7,dx=8mm dy=8mm dz=5mm
Variation (%)	-0.840000
SAR 10g (W/Kg)	0.433464
SAR 1g (W/Kg)	0.728054

**SURFACE SAR**

**VOLUME SAR**

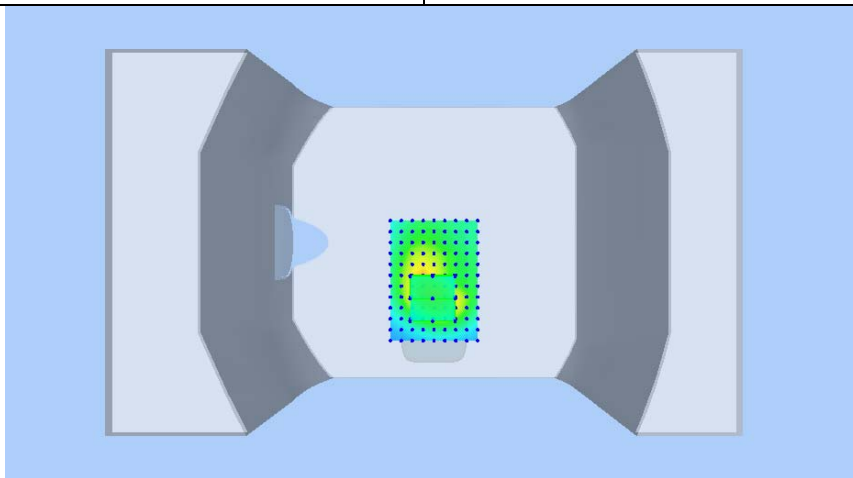
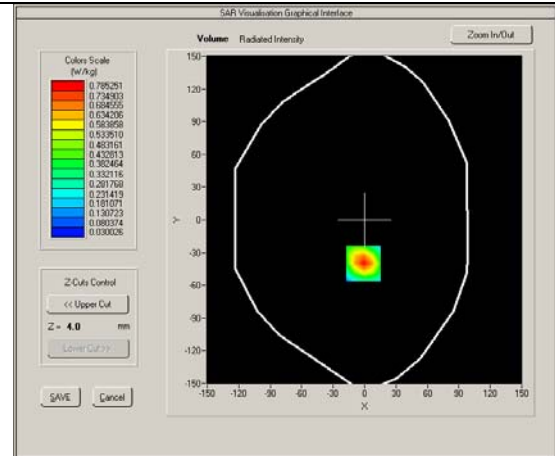
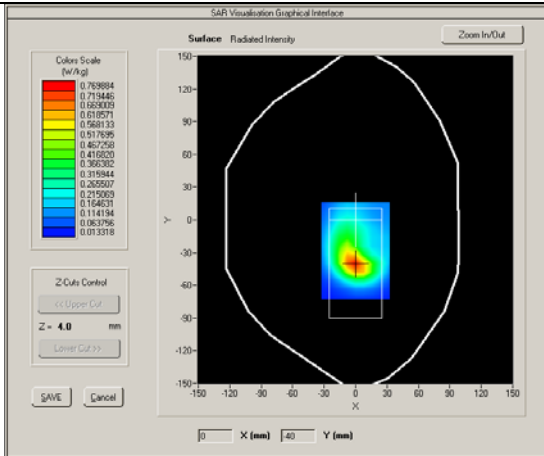

Test mode: WCDMA Band II , Middle channel (Right Head Cheek)

Product Description: Mobile Phone

Model: F55L

Test Date: December 21th, 2015

Medium(liquid type)	HSL_1900
Frequency (MHz)	1880.000
Relative permittivity (real part)	40.02
Conductivity (S/m)	1.37
E-Field Probe	SN 27/15 EPGO262
Crest factor	1.0
Conversion Factor	2.26
Sensor-Surface	4mm
Area Scan	dx=8mm dy=8mm
Zoom Scan	5x5x7,dx=8mm dy=8mm dz=5mm
Variation (%)	-0.270000
SAR 10g (W/Kg)	0.106172
SAR 1g (W/Kg)	0.173264

**SURFACE SAR**

**VOLUME SAR**

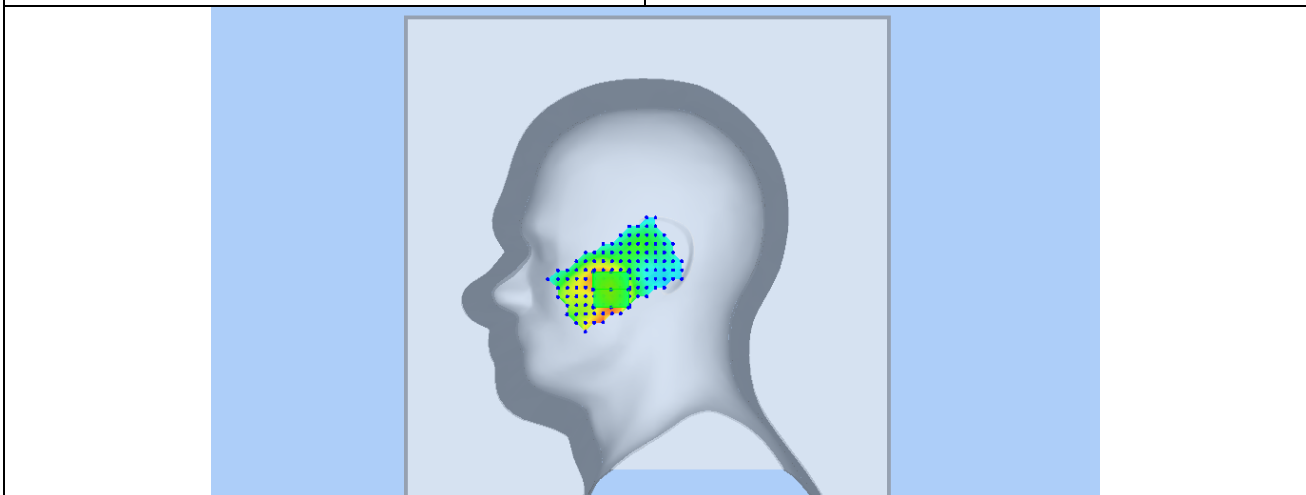
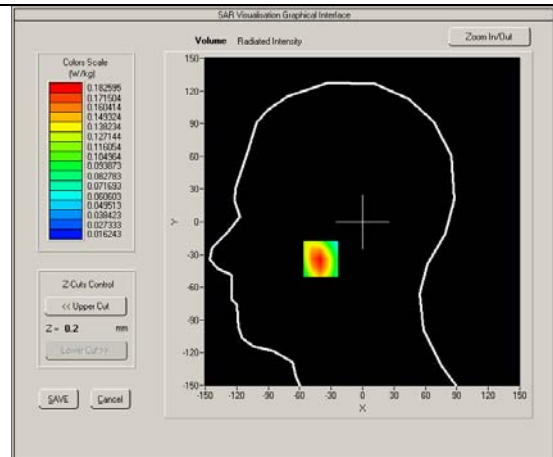
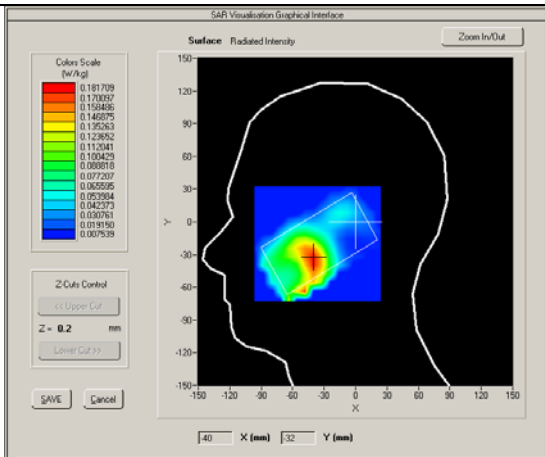

Test mode: WCDMA Band II , Middle channel (Body Back Side)

Product Description: Mobile Phone

Model: F55L

Test Date: December 22th, 2015

Medium(liquid type)	MSL_1900
Frequency (MHz)	1880.000
Relative permittivity (real part)	53.29
Conductivity (S/m)	1.51
E-Field Probe	SN 27/15 EPGO262
Crest factor	1.0
Conversion Factor	2.32
Sensor-Surface	4mm
Area Scan	dx=8mm dy=8mm
Zoom Scan	5x5x7,dx=8mm dy=8mm dz=5mm
Variation (%)	-0.60000
SAR 10g (W/Kg)	0.522100
SAR 1g (W/Kg)	0.724214

**SURFACE SAR**

**VOLUME SAR**

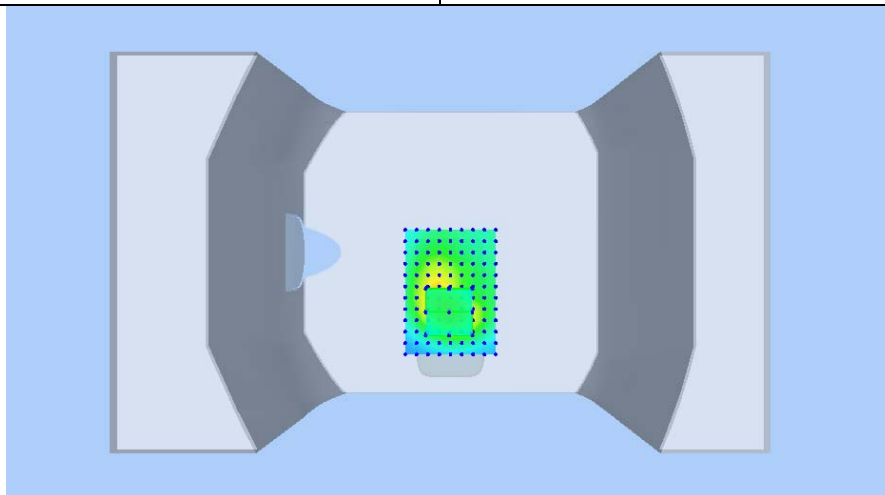
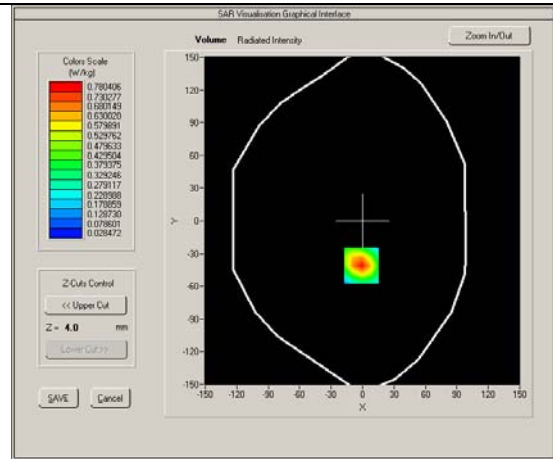
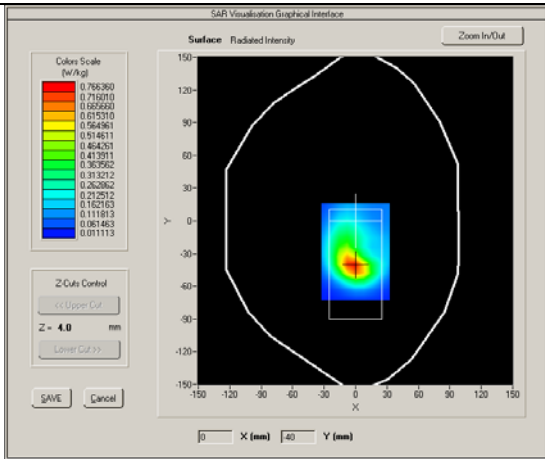

Test mode: WCDMA IV , Middle channel (Right Head Cheek)  
 Product Description: Mobile Phone  
 Model: F55L  
 Test Date: December 14th, 2015

Medium(liquid type)	HSL_1800
Frequency (MHz)	1732.600
Relative permittivity (real part)	39.96
Conductivity (S/m)	1.42
E-Field Probe	SN 27/15 EPGO262
Crest factor	1.0
Conversion Factor	2.01
Sensor-Surface	4mm
Area Scan	dx=8mm dy=8mm
Zoom Scan	5x5x7,dx=8mm dy=8mm dz=5mm
Variation (%)	2.130000
SAR 10g (W/Kg)	0.114598
SAR 1g (W/Kg)	0.224007

**SURFACE SAR**

**VOLUME SAR**

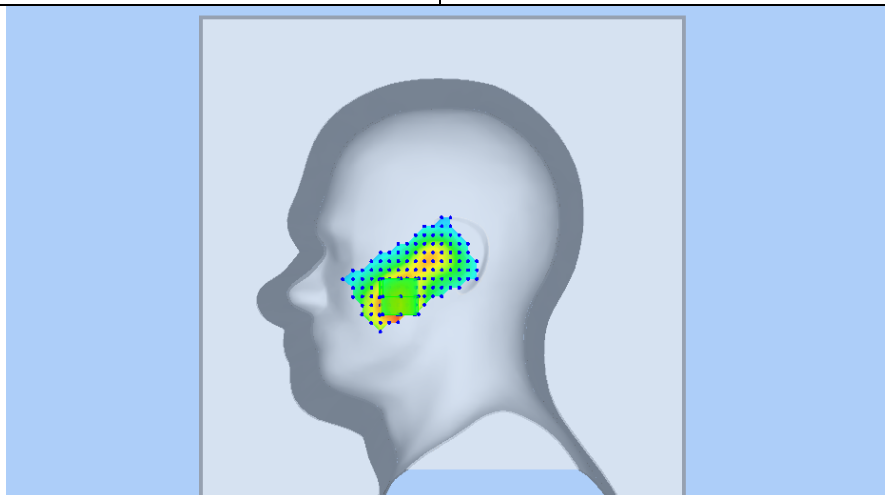
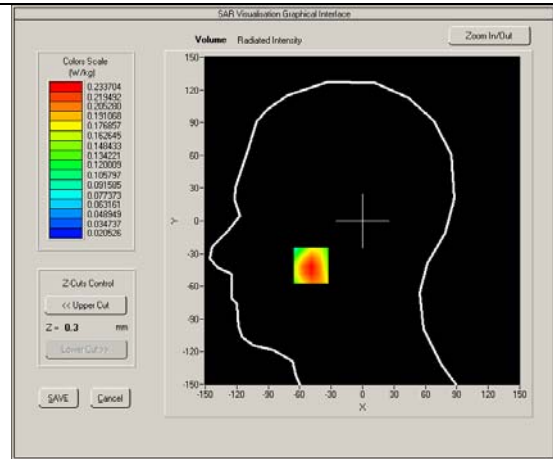
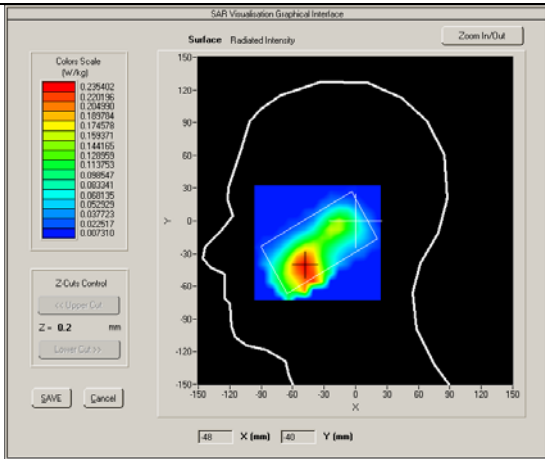

Test mode: WCDMA Band IV, Middle channel (Body Back Side)

Product Description: Mobile Phone

Model: F55L

Test Date: December 15th, 2015

Medium(liquid type)	MSL_1800
Frequency (MHz)	1712.600
Relative permittivity (real part)	53.26
Conductivity (S/m)	1.55
E-Field Probe	SN 27/15 EPGO262
Crest factor	1.0
Conversion Factor	2.05
Sensor-Surface	4mm
Area Scan	dx=8mm dy=8mm
Zoom Scan	5x5x7,dx=8mm dy=8mm dz=5mm
Variation (%)	-1.320000
SAR 10g (W/Kg)	0.429700
SAR 1g (W/Kg)	0.758094

**SURFACE SAR**

**VOLUME SAR**

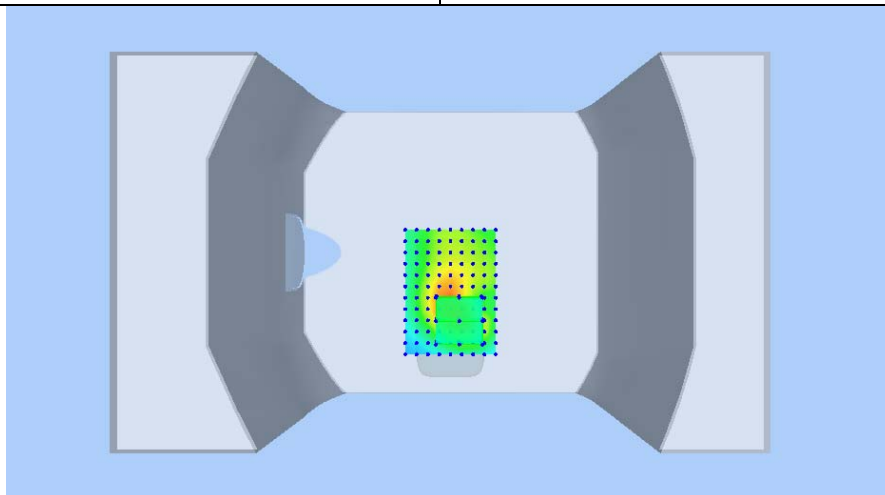
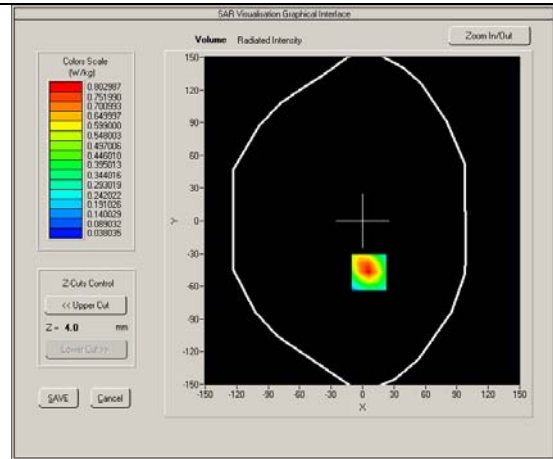
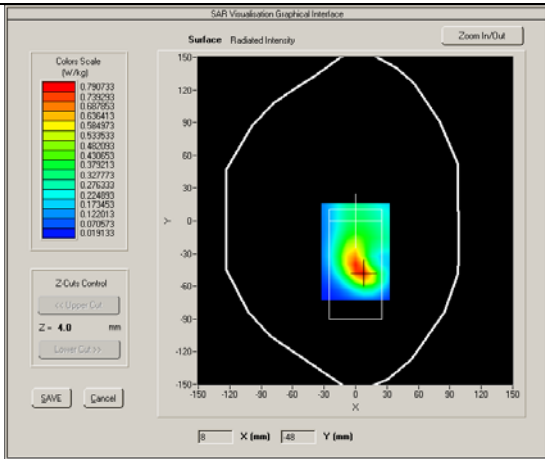

Test mode: LTE BAND 17, Middle channel (Right Head Cheek)

Product Description: Mobile Phone

Model: F55L

Test Date: December 10th, 2015

Medium(liquid type)	HSL_750
Frequency (MHz)	710.0000
Relative permittivity (real part)	41.95
Conductivity (S/m)	0.91
E-Field Probe	SN 27/15 EPGO262
Crest factor	1.0
Conversion Factor	1.68
Sensor-Surface	4mm
Bandwidth(MHz)	10
RB Allocation	1
RB Offset	24
Area Scan	dx=8mm dy=8mm
Zoom Scan	5x5x7,dx=8mm dy=8mm dz=5mm
Variation (%)	-1.61000
SAR 10g (W/Kg)	0.082516
SAR 1g (W/Kg)	0.100002

**SURFACE SAR**

**VOLUME SAR**

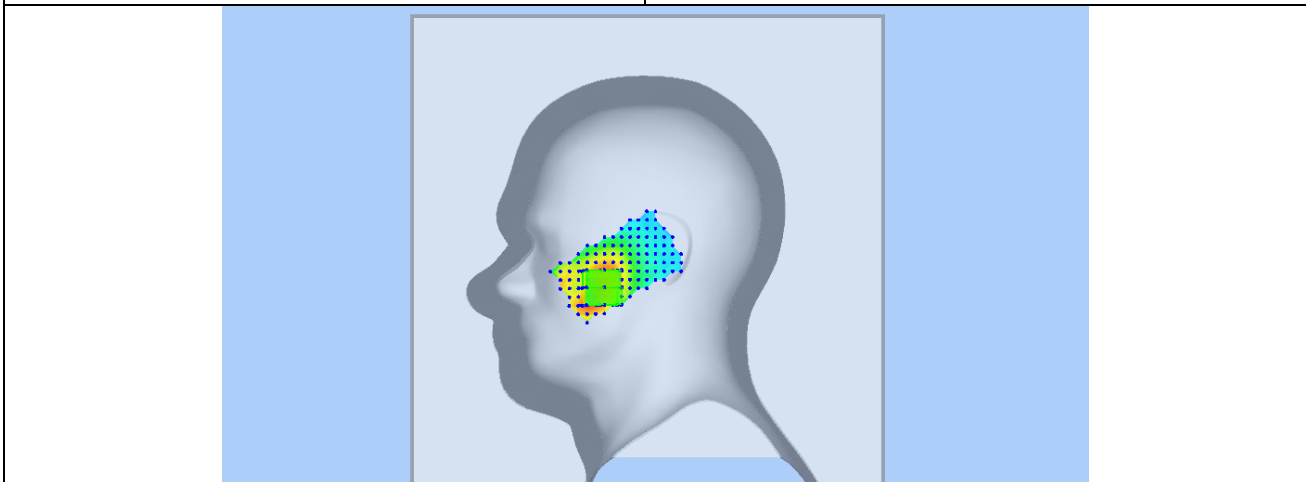
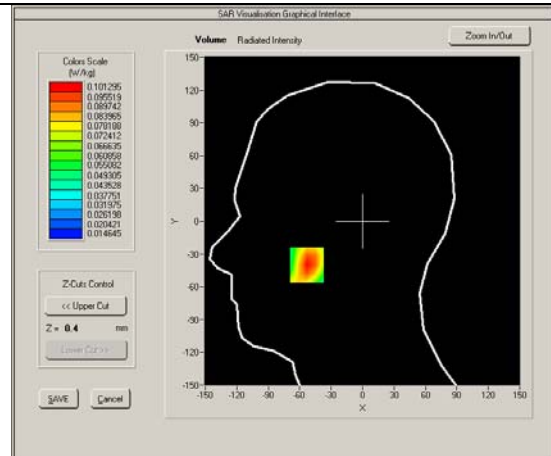
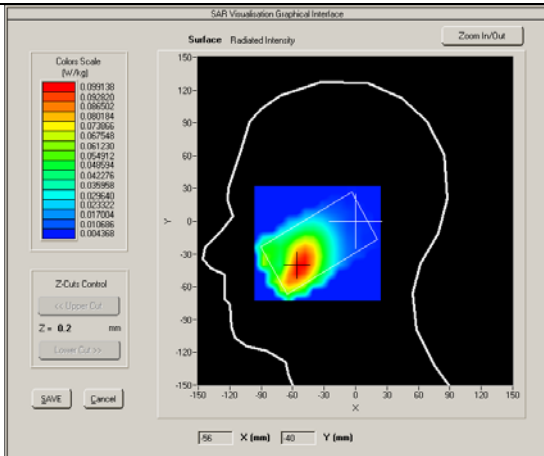

Test mode: LTE BAND 17, Middle channel (Body Down Side)

Product Description: Mobile Phone

Model: F55L

Test Date: December 11th, 2015

Medium(liquid type)	MSL_750
Frequency (MHz)	710.0000
Relative permittivity (real part)	55.56
Conductivity (S/m)	0.97
E-Field Probe	SN 27/15 EPGO262
Crest factor	1.0
Conversion Factor	1.74
Sensor-Surface	4mm
Bandwidth(MHz)	10
RB Allocation	1
RB Offset	24
Area Scan	dx=8mm dy=8mm
Zoom Scan	5x5x7,dx=8mm dy=8mm dz=5mm
Variation (%)	3.130000
SAR 10g (W/Kg)	0.240168
SAR 1g (W/Kg)	0.391107

**SURFACE SAR**

**VOLUME SAR**

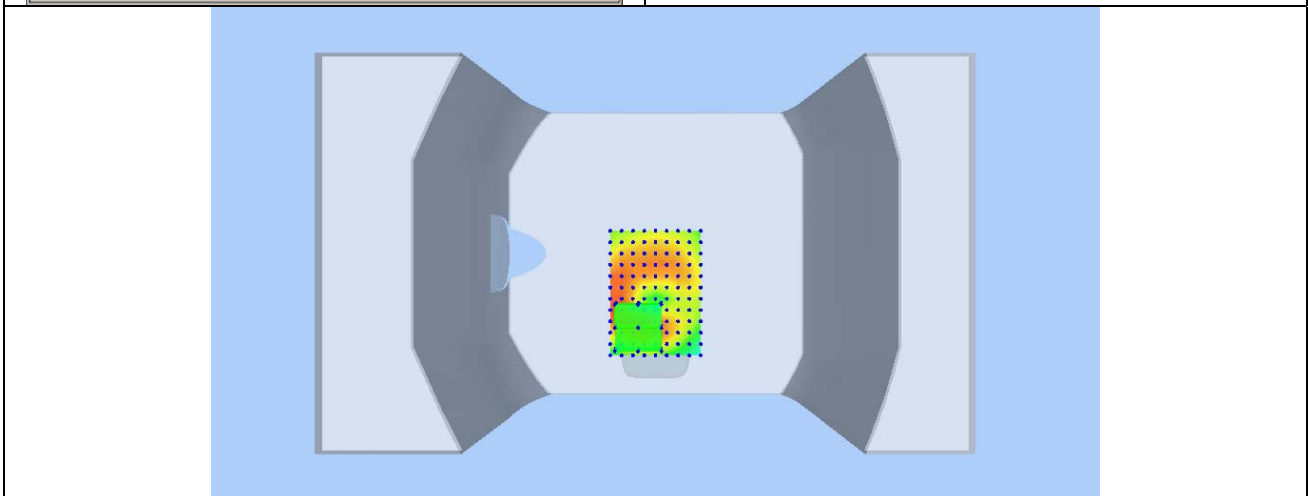
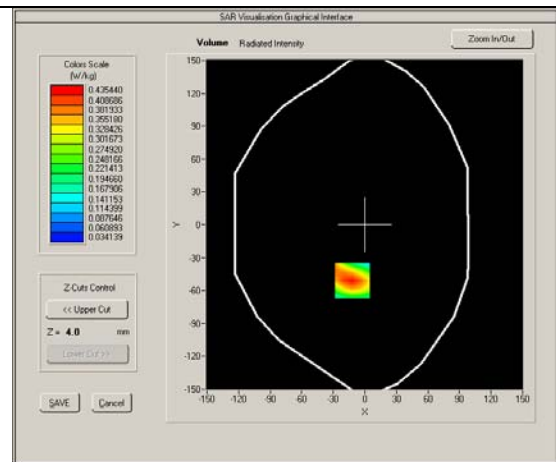
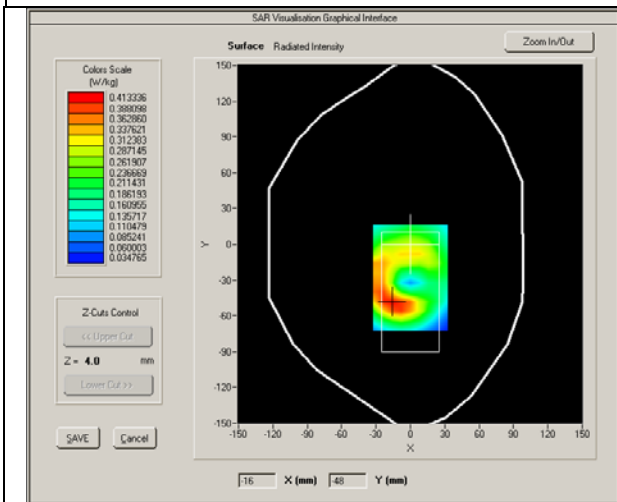



Test mode: LTE BAND 12, Middle channel (Left Head Cheek)

Product Description: Mobile Phone

Model: F55L

Test Date: December 10th, 2015

Medium (liquid type)	HSL_750
Frequency (MHz)	710.0000
Relative permittivity (real part)	41.96
Conductivity (S/m)	0.87
E-Field Probe	SN 27/15 EPGO262
Crest factor	1.0
Conversion Factor	1.68
Sensor-Surface	4mm
Bandwidth (MHz)	10
RB Allocation	1
RB Offset	24
Area Scan	dx=8mm dy=8mm
Zoom Scan	5x5x7, dx=8mm dy=8mm dz=5mm
Variation (%)	-2.53000
SAR 10g (W/Kg)	0.076214
SAR 1g (W/Kg)	0.114025

**SURFACE SAR**

**VOLUME SAR**

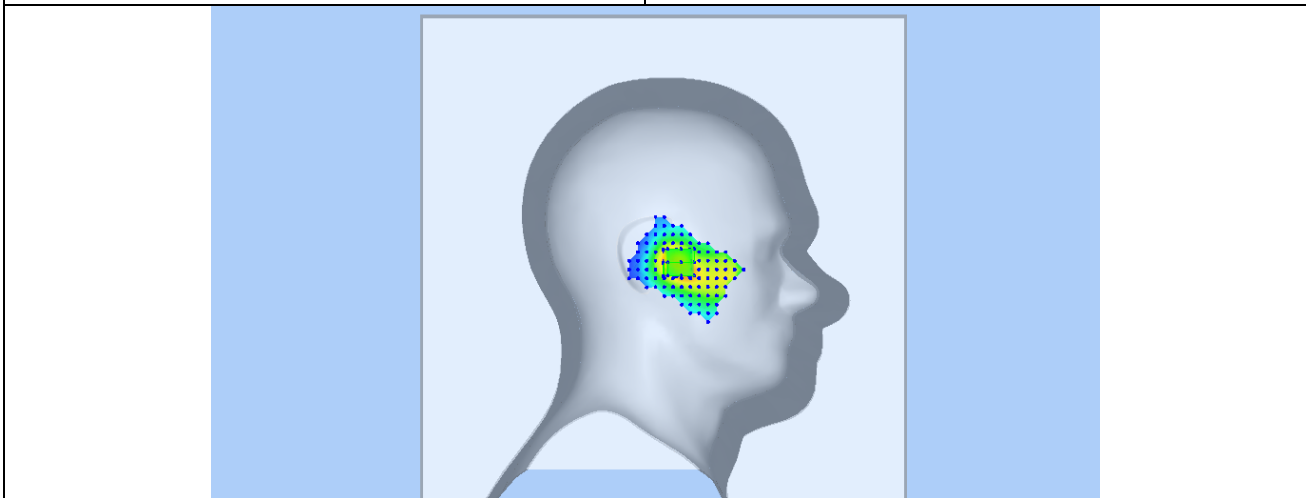
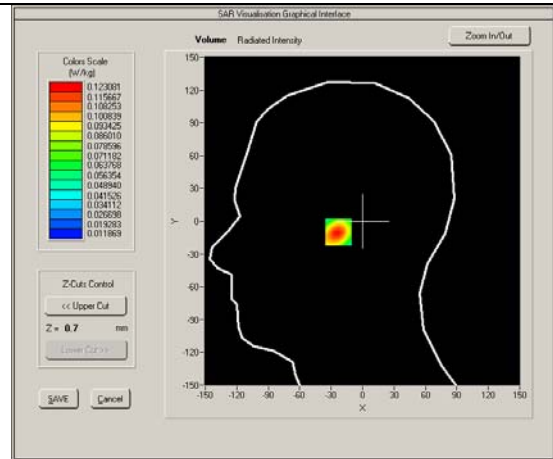
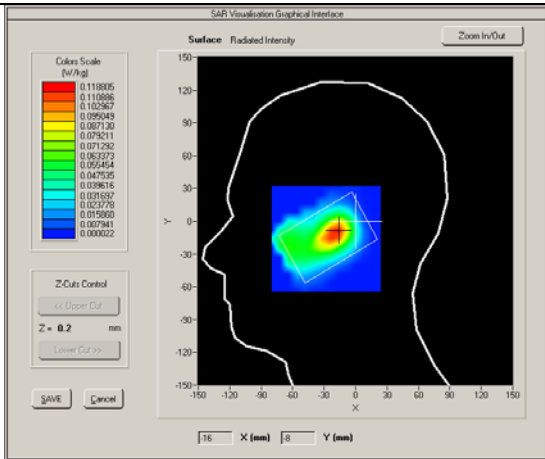

Test mode: LTE BAND 12, Mid channel (Body Down Side)

Product Description: Mobile Phone

Model: F55L

Test Date: December 11th, 2015

Medium(liquid type)	MSL_750
Frequency (MHz)	710.0000
Relative permittivity (real part)	55.57
Conductivity (S/m)	0.94
E-Field Probe	SN 27/15 EPGO262
Crest factor	1.0
Conversion Factor	1.74
Sensor-Surface	4mm
Bandwidth(MHz)	10
RB Allocation	1
RB Offset	24
Area Scan	dx=8mm dy=8mm
Zoom Scan	5x5x7,dx=8mm dy=8mm dz=5mm
Variation (%)	-1.31000
SAR 10g (W/Kg)	0.194516
SAR 1g (W/Kg)	0.387251

**SURFACE SAR**

**VOLUME SAR**

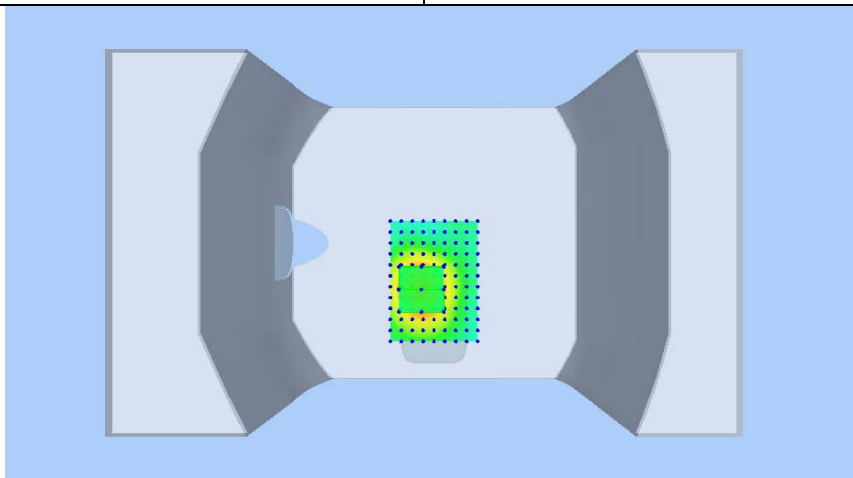
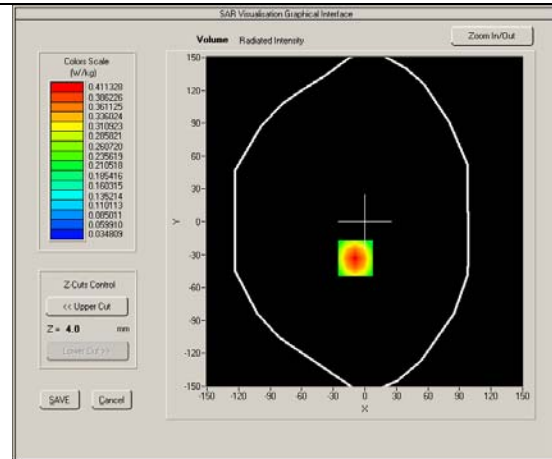
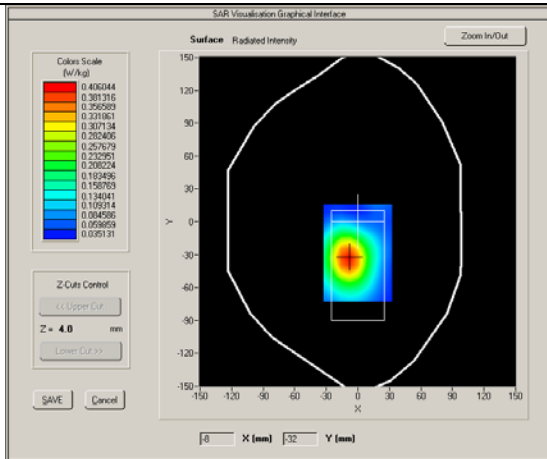

Test mode: LTE BAND 7, Middle channel (Right Head Cheek)

Product Description: Mobile Phone

Model: F55L

Test Date: December 23th, 2015

Medium(liquid type)	HSL 2600
Frequency (MHz)	2535.0000
Relative permittivity (real part)	55.29
Conductivity (S/m)	1.97
E-Field Probe	SN 27/15 EPGO262
Crest factor	1.0
Conversion Factor	2.28
Sensor-Surface	4mm
Bandwidth(MHz)	20
RB Allocation	1
RB Offset	49
Area Scan	dx=8mm dy=8mm
Zoom Scan	5x5x7,dx=8mm dy=8mm dz=5mm
Variation (%)	-0.58000
SAR 10g (W/Kg)	0.077654
SAR 1g (W/Kg)	0.101412
<b>SURFACE SAR</b>	<b>VOLUME SAR</b>

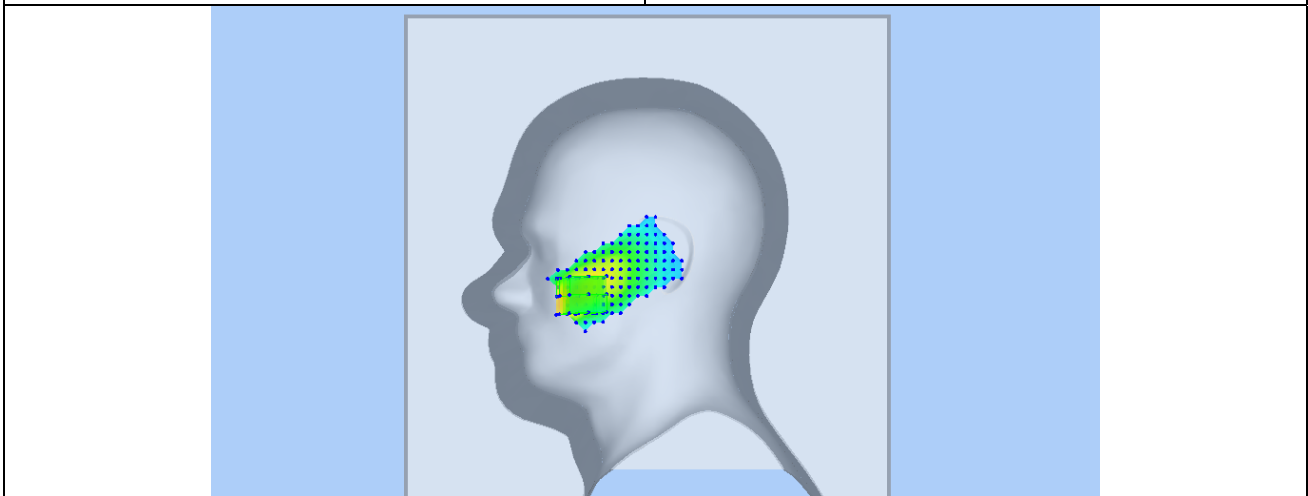
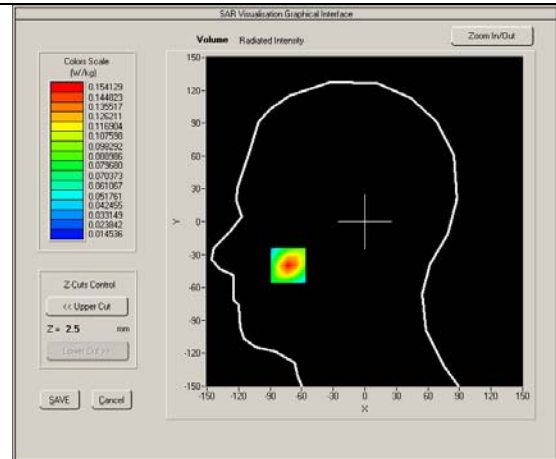
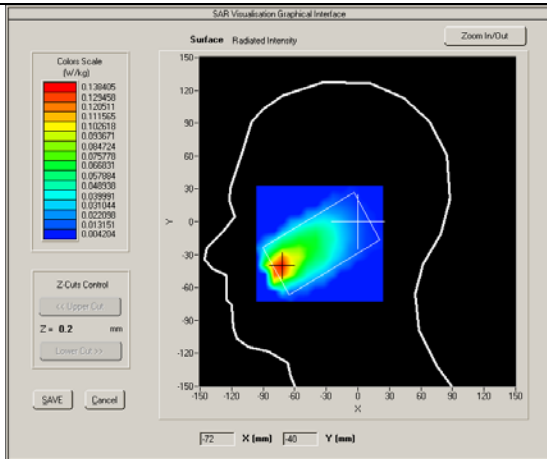

Test mode: LTE BAND 7, Mid channel (Body Down Side)  
 Product Description: Mobile Phone  
 Model: F55L  
 Test Date: December 24th, 2015

Medium(liquid type)	MSL_2600
Frequency (MHz)	2535.0000
Relative permittivity (real part)	51.96
Conductivity (S/m)	2.17
E-Field Probe	SN 27/15 EPGO262
Crest factor	1.0
Conversion Factor	2.34
Sensor-Surface	4mm
Bandwidth(MHz)	20
RB Allocation	1
RB Offset	49
Area Scan	dx=8mm dy=8mm
Zoom Scan	5x5x7,dx=8mm dy=8mm dz=5mm
Variation (%)	-1.62000
SAR 10g (W/Kg)	0.156527
SAR 1g (W/Kg)	0.316192

**SURFACE SAR**

**VOLUME SAR**

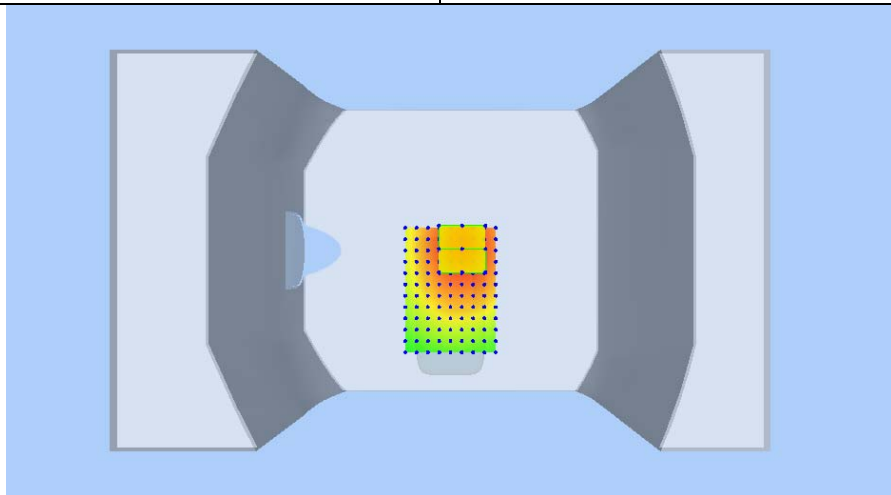
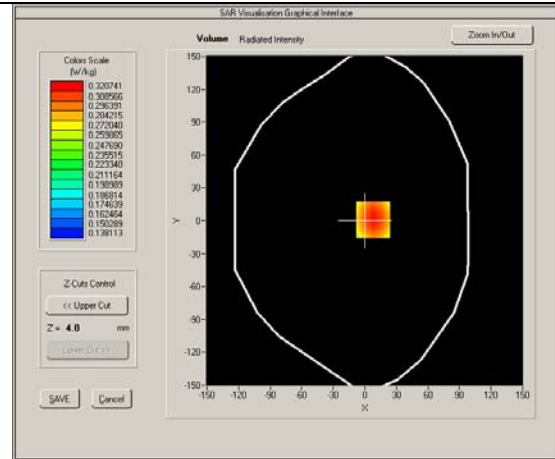
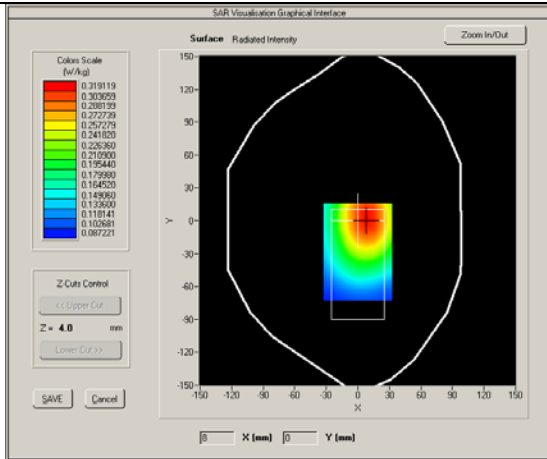

Test mode: LTE BAND 5, Middle channel (Right Head Cheek)  
 Product Description: Mobile Phone  
 Model: F55L  
 Test Date: December 14th, 2015

Medium(liquid type)	HSL_835
Frequency (MHz)	836.5000
Relative permittivity (real part)	41.3
Conductivity (S/m)	0.93
E-Field Probe	SN 27/15 EPGO262
Crest factor	1.0
Conversion Factor	1.90
Sensor-Surface	4mm
Bandwidth(MHz)	10
RB Allocation	1
RB Offset	24
Area Scan	dx=8mm dy=8mm
Zoom Scan	5x5x7,dx=8mm dy=8mm dz=5mm
Variation (%)	1.040000
SAR 10g (W/Kg)	0.056522
SAR 1g (W/Kg)	0.109412

**SURFACE SAR**

**VOLUME SAR**

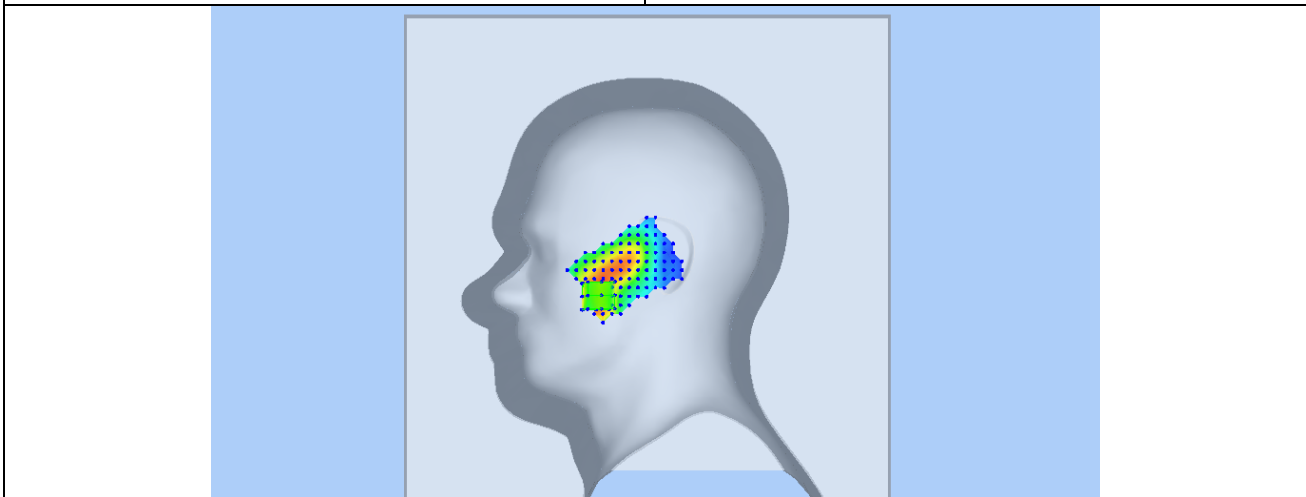
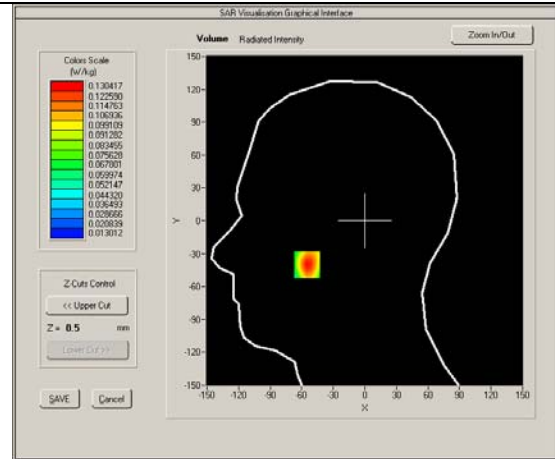
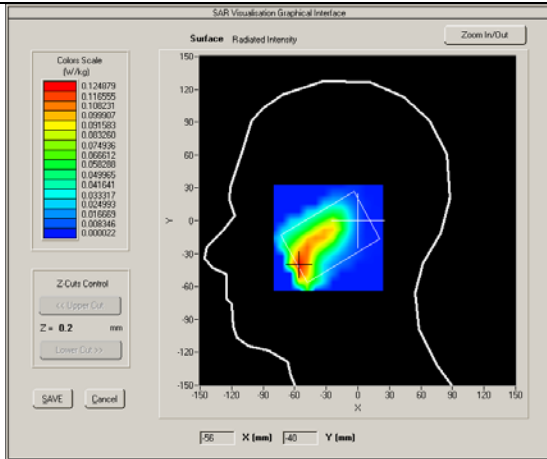

Test mode: LTE BAND 5, Middle channel (Body Down Side)  
 Product Description: Mobile Phone  
 Model: F55L  
 Test Date: December 15th, 2015

Medium(liquid type)	MSL_835
Frequency (MHz)	836.5000
Relative permittivity (real part)	55.19
Conductivity (S/m)	0.98
E-Field Probe	SN 27/15 EPGO262
Crest factor	1.0
Conversion Factor	1.97
Sensor-Surface	4mm
Bandwidth(MHz)	10
RB Allocation	1
RB Offset	24
Area Scan	dx=8mm dy=8mm
Zoom Scan	5x5x7,dx=8mm dy=8mm dz=5mm
Variation (%)	-1.21000
SAR 10g (W/Kg)	0.167508
SAR 1g (W/Kg)	0.317123

**SURFACE SAR**

**VOLUME SAR**

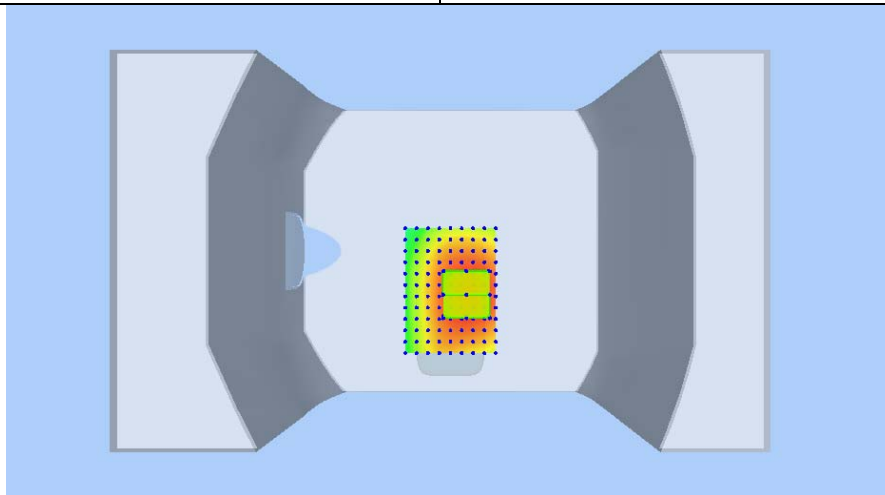
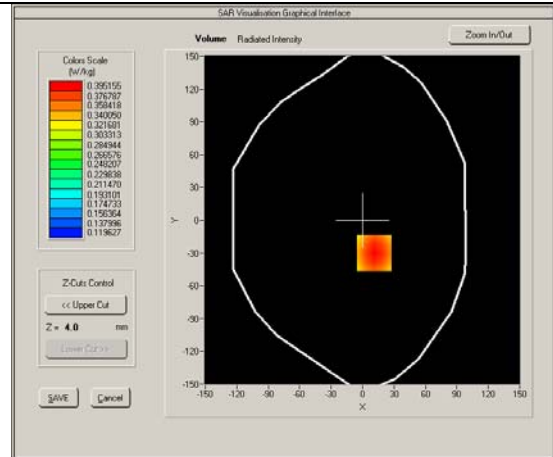
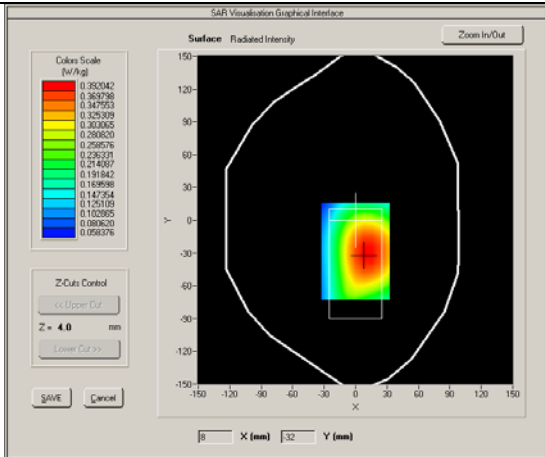

Test mode: LTE BAND 4, Middle channel (Left Head Cheek)  
 Product Description: Mobile Phone  
 Model: F55L  
 Test Date: December 17th, 2015

Medium(liquid type)	HSL 1700
Frequency (MHz)	1732.5000
Relative permittivity (real part)	39.98
Conductivity (S/m)	1.41
E-Field Probe	SN 27/15 EPGO262
Crest factor	1.0
Conversion Factor	2.01
Sensor-Surface	4mm
Bandwidth(MHz)	20
RB Allocation	1
RB Offset	50
Area Scan	dx=8mm dy=8mm
Zoom Scan	5x5x7,dx=8mm dy=8mm dz=5mm
Variation (%)	0.410000
SAR 10g (W/Kg)	0.056056
SAR 1g (W/Kg)	0.095127

**SURFACE SAR**

**VOLUME SAR**

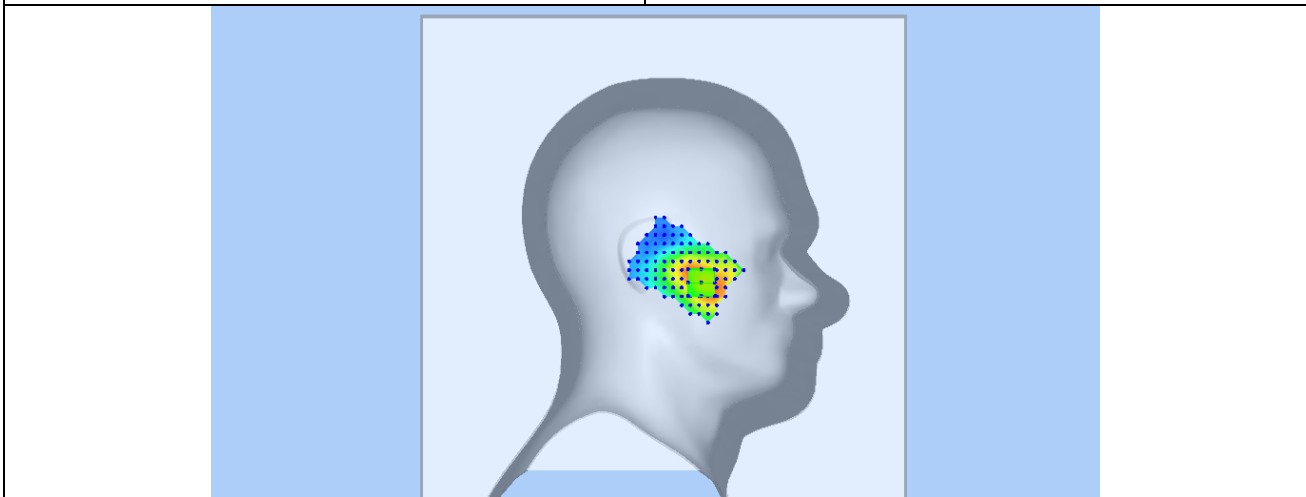
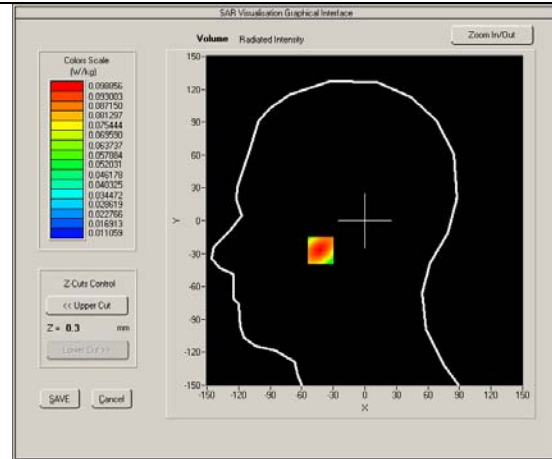
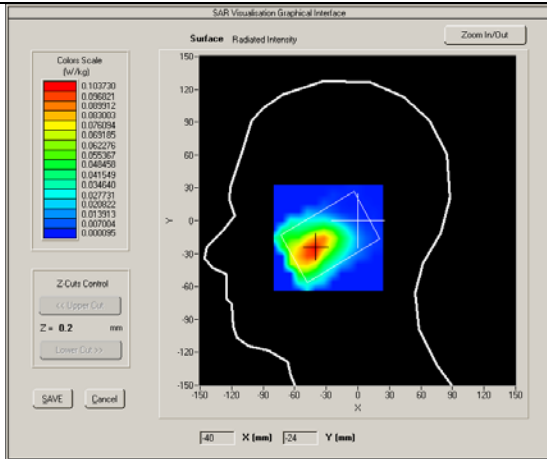

Test mode: LTE BAND 4, Middle channel (Body Down Side)  
 Product Description: Mobile Phone  
 Model: F55L  
 Test Date: December 18th, 2015

Medium(liquid type)	MSL_1800
Frequency (MHz)	1732.5000
Relative permittivity (real part)	53.25
Conductivity (S/m)	1.56
E-Field Probe	SN 27/15 EPGO262
Crest factor	1.0
Conversion Factor	2.05
Sensor-Surface	4mm
Bandwidth(MHz)	20
RB Allocation	1
RB Offset	50
Area Scan	dx=8mm dy=8mm
Zoom Scan	5x5x7,dx=8mm dy=8mm dz=5mm
Variation (%)	-0.52000
SAR 10g (W/Kg)	0.132654
SAR 1g (W/Kg)	0.273129

**SURFACE SAR**

**VOLUME SAR**

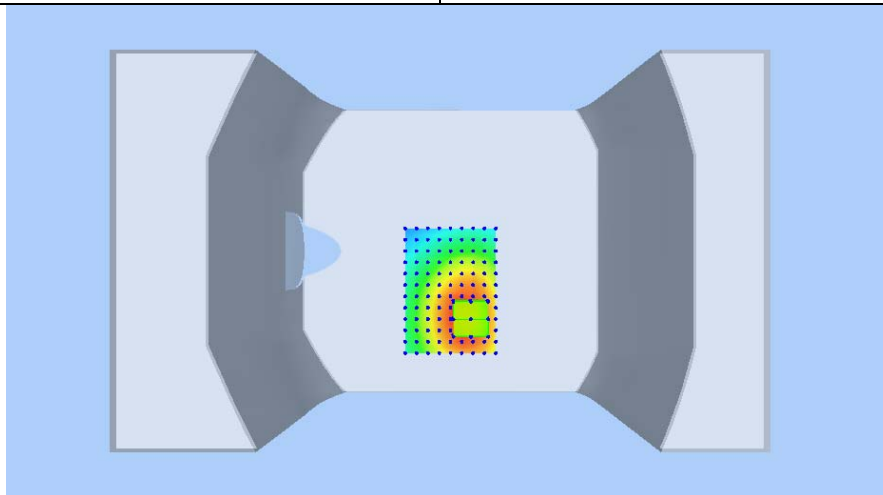
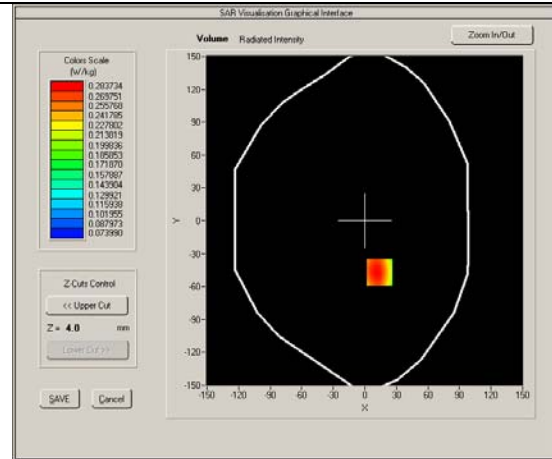
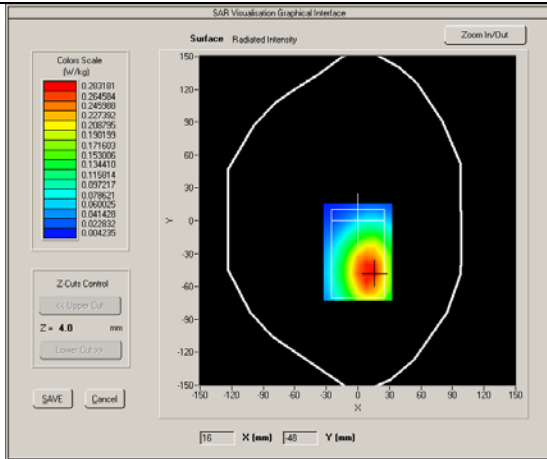



Test mode: LTE BAND 2, Middle channel (Right Head Cheek)  
 Product Description: Mobile Phone  
 Model: F55L  
 Test Date: December 21th, 2015

Medium(liquid type)	HSL 1900
Frequency (MHz)	1880.0000
Relative permittivity (real part)	40.03
Conductivity (S/m)	1.39
E-Field Probe	SN 27/15 EPGO262
Crest factor	1.0
Conversion Factor	2.26
Sensor-Surface	4mm
Bandwidth(MHz)	20
RB Allocation	1
RB Offset	49
Area Scan	dx=8mm dy=8mm
Zoom Scan	5x5x7,dx=8mm dy=8mm dz=5mm
Variation (%)	1.350000
SAR 10g (W/Kg)	0.052216
SAR 1g (W/Kg)	0.105261

**SURFACE SAR**

**VOLUME SAR**

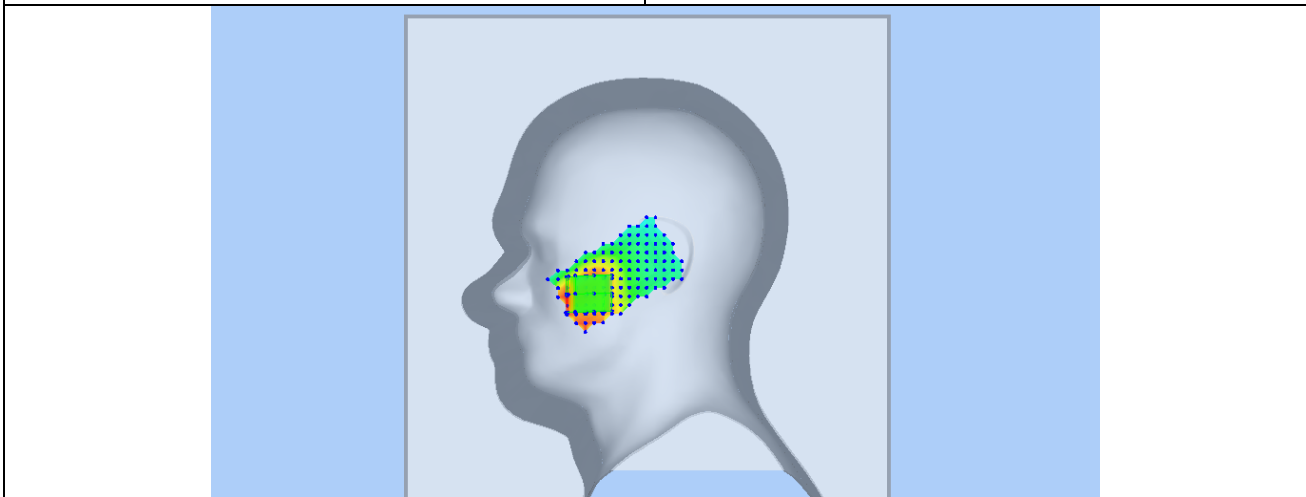
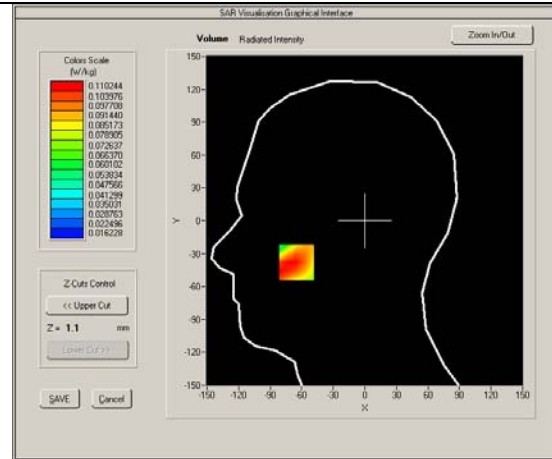
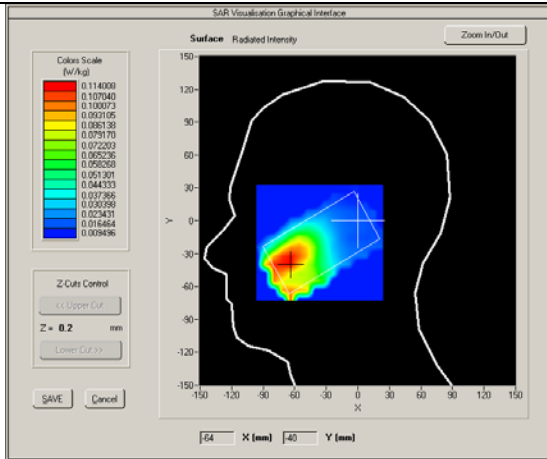

Test mode: LTE BAND 2, Middle channel (Body Down Side)  
 Product Description: Mobile Phone  
 Model: F55L  
 Test Date: December 22th, 2015

Medium(liquid type)	MSL_1900
Frequency (MHz)	1880.0000
Relative permittivity (real part)	53.28
Conductivity (S/m)	1.53
E-Field Probe	SN 27/15 EPGO262
Crest factor	1.0
Conversion Factor	2.32
Sensor-Surface	4mm
Bandwidth(MHz)	20
RB Allocation	1
RB Offset	49
Area Scan	dx=8mm dy=8mm
Zoom Scan	5x5x7,dx=8mm dy=8mm dz=5mm
Variation (%)	-0.88000
SAR 10g (W/Kg)	0.139451
SAR 1g (W/Kg)	0.307104

**SURFACE SAR**

**VOLUME SAR**

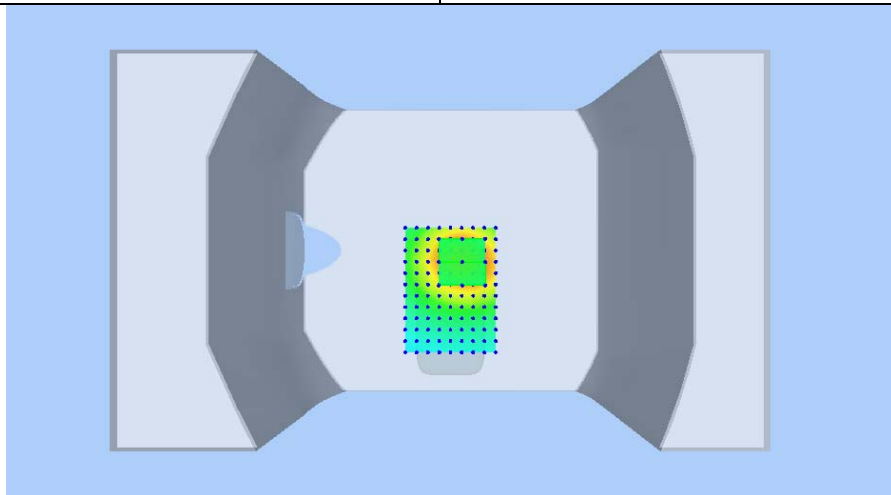
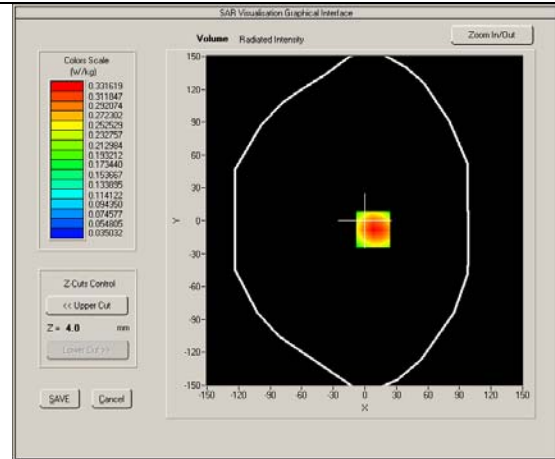
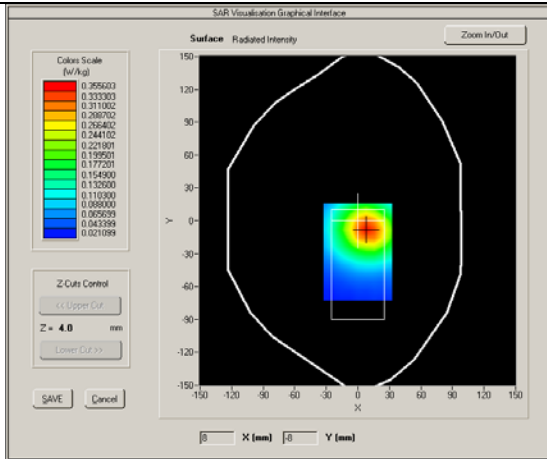

## Annex A CALIBRATION REPORTS

### SARTIMO Calibration Certificate-Extended Dipole Calibrations

According to KDB865664 D01, Dipoles must be recalibrated at least once every three years; however, immediate re-calibration is required for following conditions. The test laboratory must ensure that the required supporting information and documentation have been included in the SAR report to qualify for extended 3-year calibration interval.

- 1) When the most recent return-loss, measured at least annually, deviates by more than 20% from the previous measurement (i.e. 0.2 of the dB value) or not meeting the required -20 dB return-loss specification
- 2) When the most recent measurement of the real or imaginary parts of the impedance, measured at least annually, deviates by more than  $5\Omega$  from the previous measurement

### Dipole Verification plot: SID 750 SN 26/14 DIP 0G750-325 750MHz for Head:

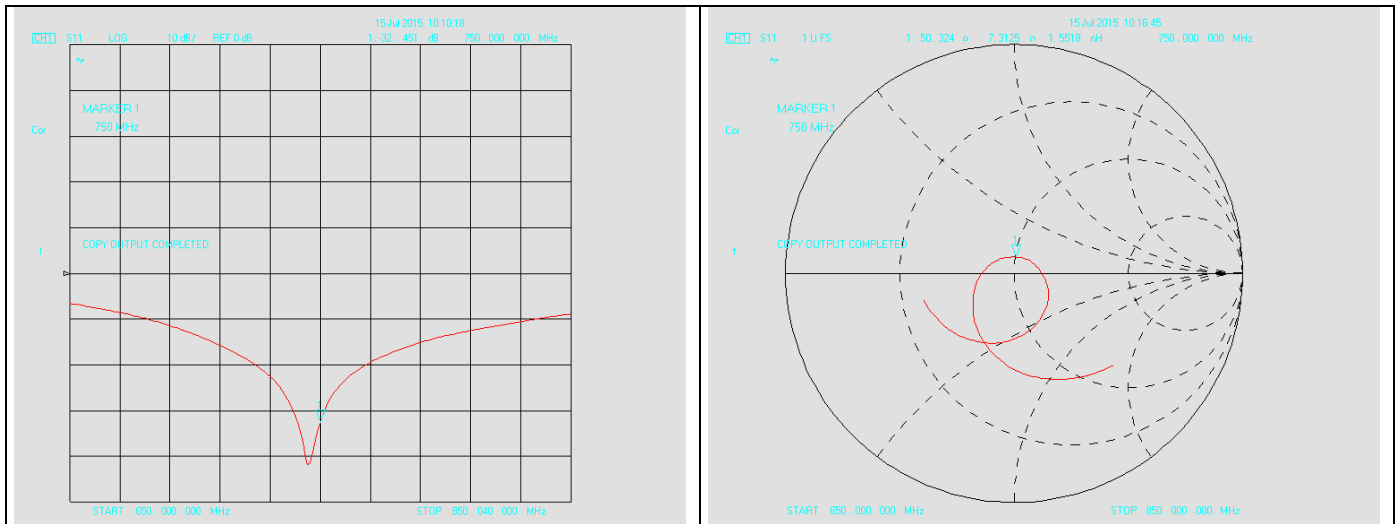

### 750MHz for Body:

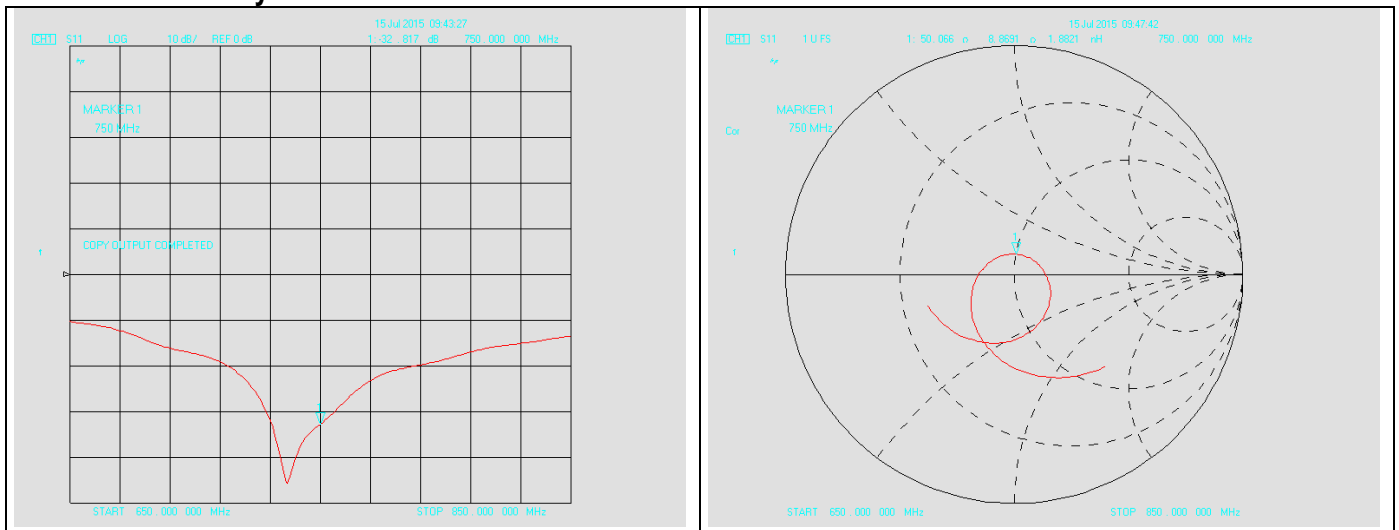

Test Report	15071166-FCC-H
Page	108 of 166

**Dipole Verification plot: SID 835 SN 18/11 DIPC150  
 835MHz for Head:**

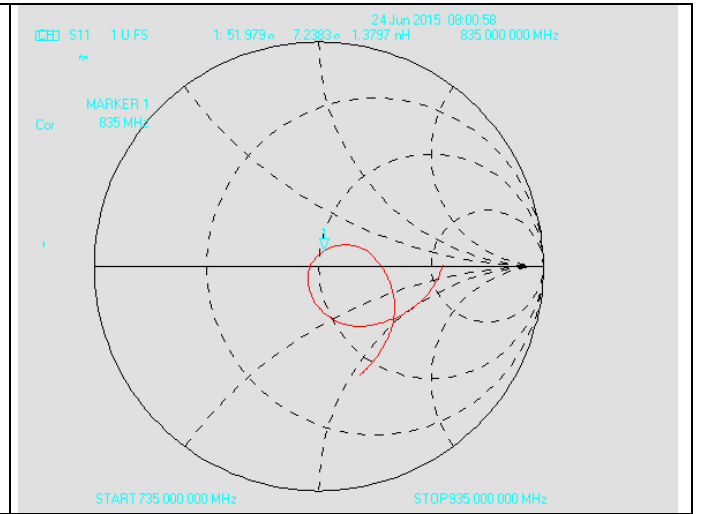
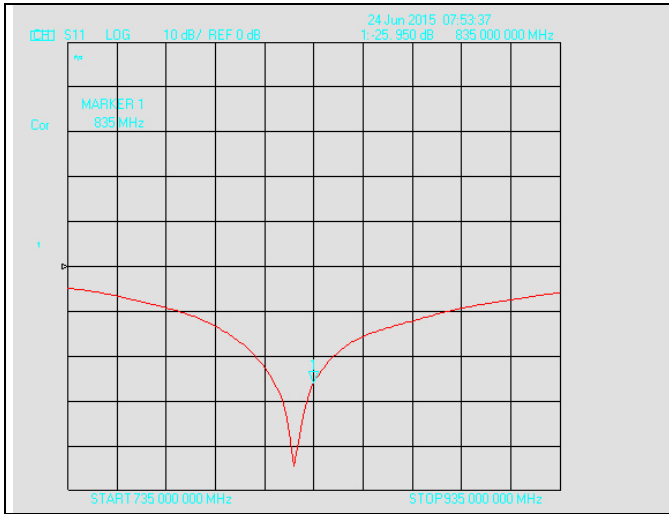

**835MHz for Body:**

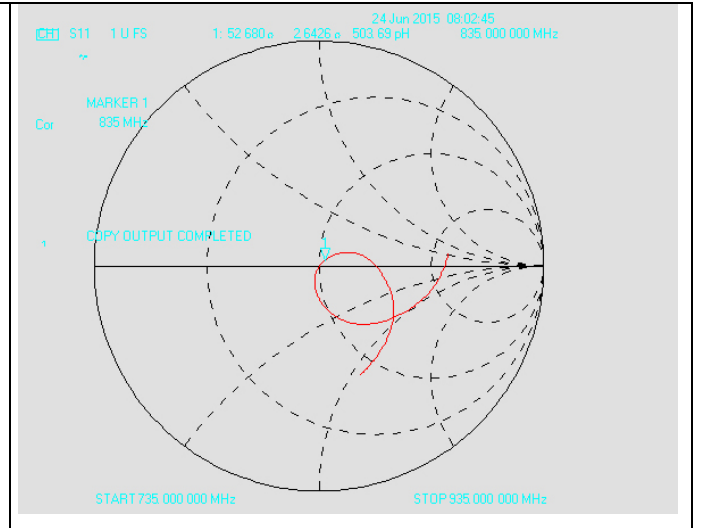
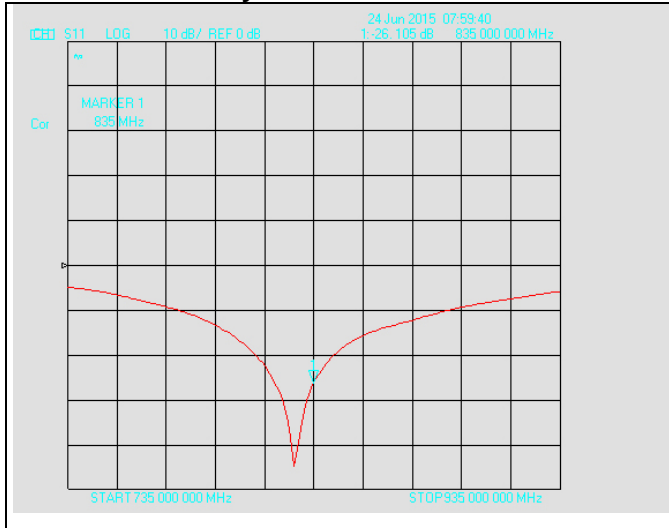

**Dipole Verification plot: SID 1800 SN 18/11 DIPF152**

**1800MHz for Head:**

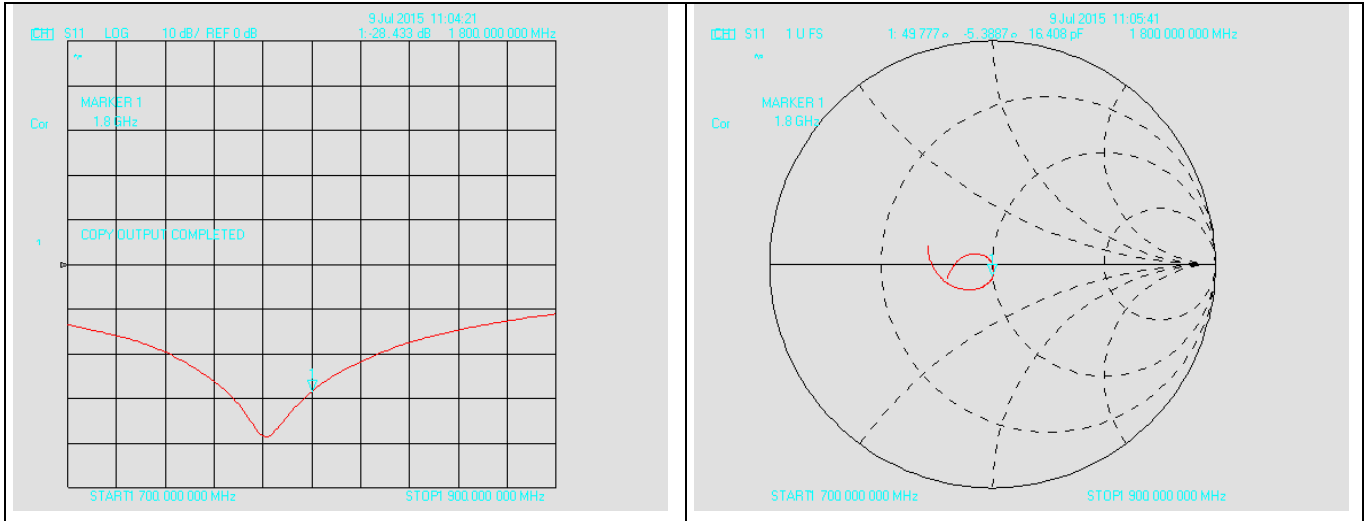

**1800MHz for Body:**

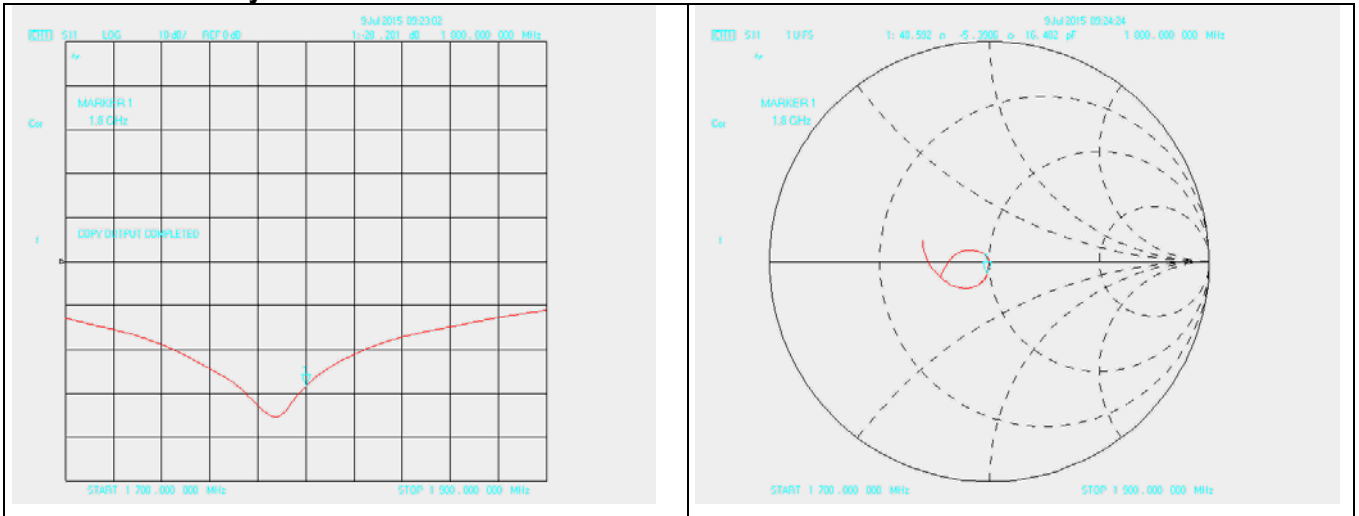

**Dipole Verification plot: SID 1900 SN 18/11 DIPG153**

**1900MHz for Head:**

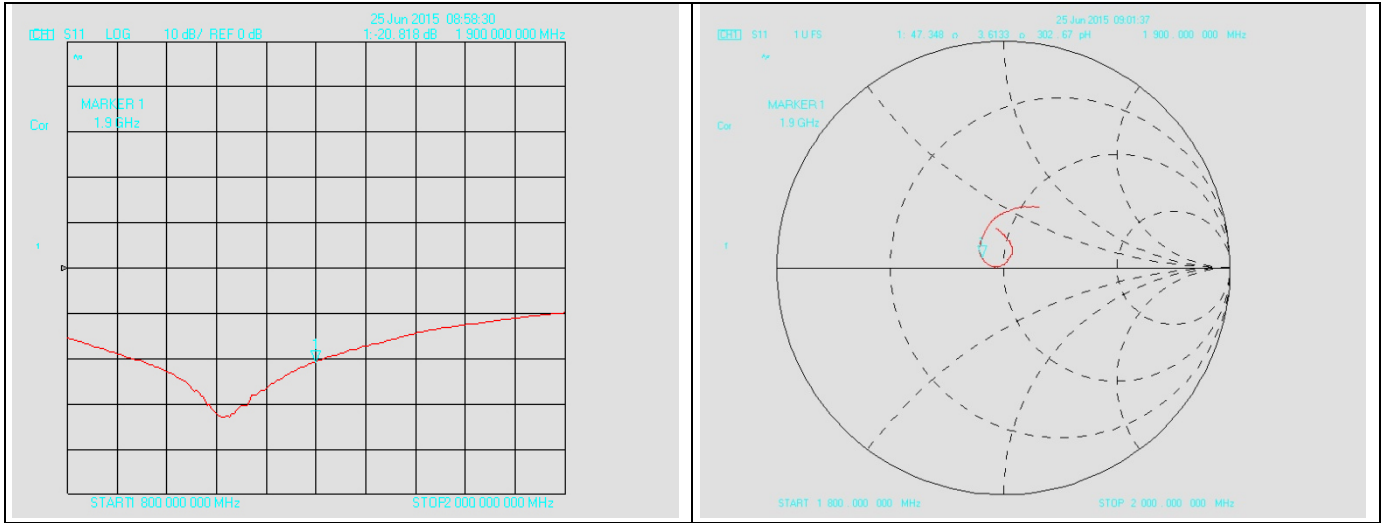

**1900MHz for Body:**

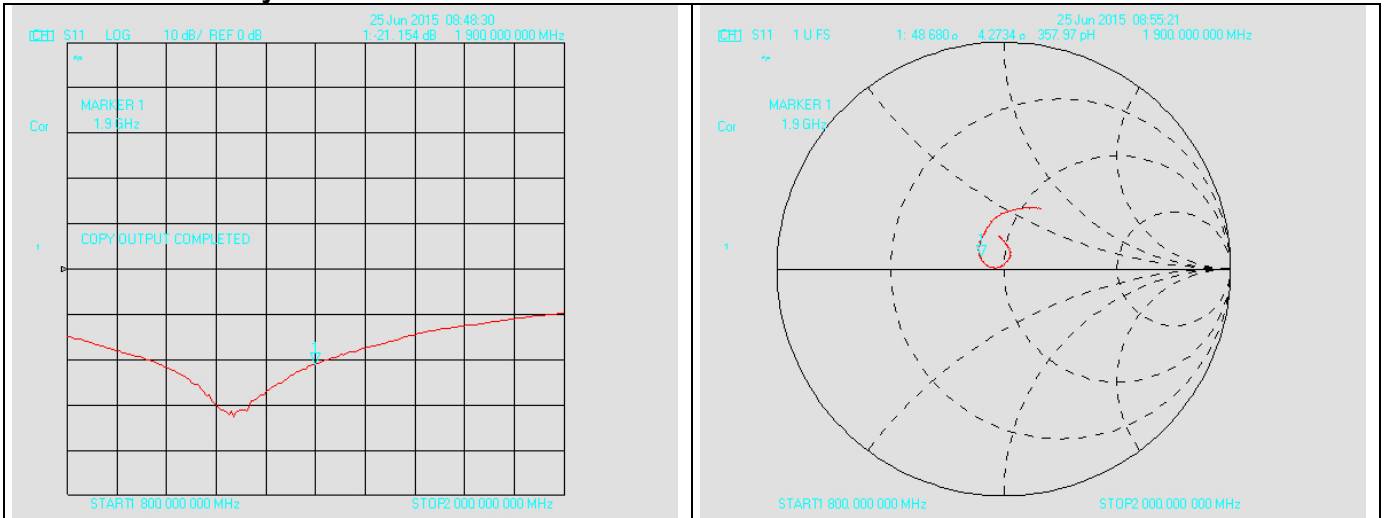

SID 750 SN 26/14 DIP 0G750-325 For Head					
Return- Loss (dB)	Deviate (dB)	Real Impedance ( $\Omega$ )	Imaginary Impedance ( $\Omega$ )	Deviate ( $\Omega$ )	Calibrate Date
-32.51	-----	-----	50	-----	07/03/2014
-32.451	0.059	50.324	50	0.324	07/15/2015
SID 750 SN 26/14 DIP 0G750-325 For Body					
-32.817	-0.307	50.066	50	0.066	07/15/2015

SID 835 SN 18/11 DIPC150 For Head					
Return- Loss (dB)	Deviate (dB)	Real Impedance ( $\Omega$ )	Imaginary Impedance ( $\Omega$ )	Deviate ( $\Omega$ )	Calibrate Date
-26.34	-----	-----	50	-----	06/018/2014
-25.95	0.39	51.979	50	1.979	06/24/2015
SID 835 SN 18/11 DIPC150 For Body					
-26.105	0.235	52.68	50	2.68	06/24/2015

SID 1800 SN 18/11 DIPF152 For Head					
Return- Loss (dB)	Deviate (dB)	Real Impedance ( $\Omega$ )	Imaginary Impedance ( $\Omega$ )	Deviate ( $\Omega$ )	Calibrate Date
-28.21	-----	-----	50	-----	06/18/2014
-28.433	-0.223	49.777	50	-0.223	07/09/2015
SID 1800 SN 18/11 DIPF152 For Body					
-28.281	-0.071	48.592	50	-1.408	07/09/2015

SID 1900 SN 18/11 DIPG153 For Head					
Return- Loss (dB)	Deviate (dB)	Real Impedance ( $\Omega$ )	Imaginary Impedance ( $\Omega$ )	Deviate ( $\Omega$ )	Calibrate Date
-21.22	-----	-----	50	-----	06/18/2014
-20.818	0.402	47.348	50	-2.652	06/25/2015
SID 1900 SN 18/11 DIPG153 For Body					
-21.154	0.066	48.680	50	-1.32	06/25/2015

According to up table, the return loss is <-20dB, deviates by less than 20% from the previous measurement; the real impedance are all within 5  $\Omega$  compared to the required impedance (50  $\Omega$ ).

Test Report	15071166-FCC-H
Page	112 of 166



## COMOSAR E-Field Probe Calibration Report

Ref : ACR.265.1.15.SATU.A

### SIEMIC TESTING AND CERTIFICATION SERVICES

ZONE A,FLOOR 1,BUILDING 2,WAN YE LONG TECHNOLOGY PARK,SOUTH SIDE OF ZHOUSHI ROAD, SHIYAN STREET,BAO'AN DISTRICT, SHENZHEN 518108 , GUANGDONG , P.R.C.

**MVG COMOSAR DOSIMETRIC E-FIELD PROBE**  
SERIAL NO.: SN 27/15 EPGO262

Calibrated at MVG US  
2105 Barrett Park Dr. - Kennesaw, GA 30144



Calibration Date: 07/09/2015

#### Summary:

This document presents the method and results from an accredited COMOSAR Dosimetric E-Field Probe calibration performed in MVG USA using the CALISAR / CALIBAIR test bench, for use with a COMOSAR system only. All calibration results are traceable to national metrology institutions.



Test Report	15071166-FCC-H
Page	113 of 166



**COMOSAR E-FIELD PROBE CALIBRATION REPORT**

Ref: ACR.265.1.15.SATU.A

	<i>Name</i>	<i>Function</i>	<i>Date</i>	<i>Signature</i>
<i>Prepared by :</i>	Jérôme LUC	Product Manager	9/22/2015	<i>JS</i>
<i>Checked by :</i>	Jérôme LUC	Product Manager	9/22/2015	<i>JS</i>
<i>Approved by :</i>	Kim RUTKOWSKI	Quality Manager	9/22/2015	<i>Kim Rutkowski</i>

	<i>Customer Name</i>
<i>Distribution :</i>	SIEMIC TESTING AND CERTIFICATION SERVICES

<i>Issue</i>	<i>Date</i>	<i>Modifications</i>
A	9/22/2015	Initial release



**TABLE OF CONTENTS**

1	Device Under Test .....	4
2	Product Description .....	4
2.1	General Information .....	4
3	Measurement Method .....	4
3.1	Linearity .....	4
3.2	Sensitivity .....	5
3.3	Lower Detection Limit .....	5
3.4	Isotropy .....	5
3.5	Boundary Effect .....	5
4	Measurement Uncertainty .....	5
5	Calibration Measurement Results .....	6
5.1	Sensitivity in air .....	6
5.2	Linearity .....	7
5.3	Sensitivity in liquid .....	7
5.4	Isotropy .....	8
6	List of Equipment .....	10



**1 DEVICE UNDER TEST**

Device Under Test	
Device Type	COMOSAR DOSIMETRIC E FIELD PROBE
Manufacturer	MVG
Model	SSE2
Serial Number	SN 27/15 EPGO262
Product Condition (new / used)	New
Frequency Range of Probe	0.7 GHz-6GHz
Resistance of Three Dipoles at Connector	Dipole 1: R1=0.222 MΩ Dipole 2: R2=0.200 MΩ Dipole 3: R3=0.200 MΩ

A yearly calibration interval is recommended.

**2 PRODUCT DESCRIPTION**

**2.1 GENERAL INFORMATION**

MVG's COMOSAR E field Probes are built in accordance to the IEEE 1528, OET 65 Bulletin C and CEI/IEC 62209 standards.



Figure 1 – MVG COMOSAR Dosimetric E field Dipole

Probe Length	330 mm
Length of Individual Dipoles	2 mm
Maximum external diameter	8 mm
Probe Tip External Diameter	2.5 mm
Distance between dipoles / probe extremity	1 mm

**3 MEASUREMENT METHOD**

The IEEE 1528, OET 65 Bulletin C, CENELEC EN50361 and CEI/IEC 62209 standards provide recommended practices for the probe calibrations, including the performance characteristics of interest and methods by which to assess their affect. All calibrations / measurements performed meet the fore mentioned standards.

**3.1 LINEARITY**

The evaluation of the linearity was done in free space using the waveguide, performing a power sweep to cover the SAR range 0.01W/kg to 100W/kg



### 3.2 SENSITIVITY

The sensitivity factors of the three dipoles were determined using a two step calibration method (air and tissue simulating liquid) using waveguides as outlined in the standards.

### 3.3 LOWER DETECTION LIMIT

The lower detection limit was assessed using the same measurement set up as used for the linearity measurement. The required lower detection limit is 10 mW/kg.

### 3.4 ISOTROPY

The axial isotropy was evaluated by exposing the probe to a reference wave from a standard dipole with the dipole mounted under the flat phantom in the test configuration suggested for system validations and checks. The probe was rotated along its main axis from 0 - 360 degrees in 15 degree steps. The hemispherical isotropy is determined by inserting the probe in a thin plastic box filled with tissue-equivalent liquid, with the plastic box illuminated with the fields from a half wave dipole. The dipole is rotated about its axis (0°–180°) in 15° increments. At each step the probe is rotated about its axis (0°–360°).

### 3.5 BOUNDARY EFFECT

The boundary effect is defined as the deviation between the SAR measured data and the expected exponential decay in the liquid when the probe is oriented normal to the interface. To evaluate this effect, the liquid filled flat phantom is exposed to fields from either a reference dipole or waveguide. With the probe normal to the phantom surface, the peak spatial average SAR is measured and compared to the analytical value at the surface.

## 4 MEASUREMENT UNCERTAINTY

The guidelines outlined in the IEEE 1528, OET 65 Bulletin C, CENELEC EN50361 and CEI/IEC 62209 standards were followed to generate the measurement uncertainty associated with an E-field probe calibration using the waveguide technique. All uncertainties listed below represent an expanded uncertainty expressed at approximately the 95% confidence level using a coverage factor of k=2, traceable to the Internationally Accepted Guides to Measurement Uncertainty.

Uncertainty analysis of the probe calibration in waveguide					
ERROR SOURCES	Uncertainty value (%)	Probability Distribution	Divisor	ci	Standard Uncertainty (%)
Incident or forward power	3.00%	Rectangular	$\sqrt{3}$	1	1.732%
Reflected power	3.00%	Rectangular	$\sqrt{3}$		1.732%
Liquid conductivity	5.00%	Rectangular	$\sqrt{3}$		2.887%
Liquid permittivity	4.00%	Rectangular	$\sqrt{3}$		2.309%
Field homogeneity	3.00%	Rectangular	$\sqrt{3}$		1.732%
Field probe positioning	5.00%	Rectangular	$\sqrt{3}$		2.887%



**COMOSAR E-FIELD PROBE CALIBRATION REPORT**

Ref: ACR.265.1.15.SATU.A

Field probe linearity	3.00%	Rectangular	$\sqrt{3}$	1	1.732%
<b>Combined standard uncertainty</b>					5.831%
<b>Expanded uncertainty</b> 95 % confidence level k = 2					12.0%

**5 CALIBRATION MEASUREMENT RESULTS**

Calibration Parameters	
Liquid Temperature	21 °C
Lab Temperature	21 °C
Lab Humidity	45 %

**5.1 SENSITIVITY IN AIR**

Normx dipole 1 ( $\mu\text{V}/(\text{V}/\text{m})^2$ )	Normy dipole 2 ( $\mu\text{V}/(\text{V}/\text{m})^2$ )	Normz dipole 3 ( $\mu\text{V}/(\text{V}/\text{m})^2$ )
0.78	0.70	0.72

DCP dipole 1 (mV)	DCP dipole 2 (mV)	DCP dipole 3 (mV)
92	90	90

Calibration curves  $e_i=f(V)$  ( $i=1,2,3$ ) allow to obtain H-field value using the formula:

$$E = \sqrt{E_1^2 + E_2^2 + E_3^2}$$

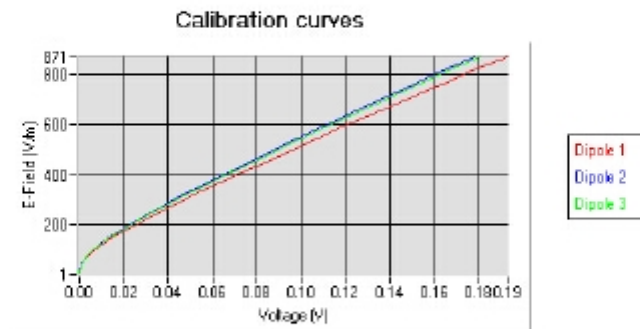



5.2 LINEARITY

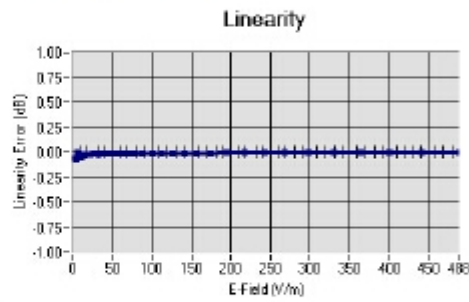

Linearity  $\pm 1.78\%$  ( $\pm 0.08\text{dB}$ )

5.3 SENSITIVITY IN LIQUID

Liquid	Frequency (MHz $\pm 100\text{MHz}$ )	Permittivity	Epsilon (S/m)	ConvF
HL750	750	41.82	0.90	1.68
BL750	750	56.28	0.98	1.74
HL850	835	42.59	0.90	1.90
BL850	835	53.19	0.97	1.97
HL900	900	42.05	0.98	1.75
BL900	900	56.41	1.08	1.81
HL1800	1800	41.82	1.38	2.01
BL1800	1800	53.00	1.52	2.05
HL1900	1900	40.38	1.41	2.26
BL1900	1900	53.93	1.55	2.32
HL2000	2000	40.12	1.43	2.16
BL2000	2000	53.65	1.54	2.25
HL2450	2450	38.34	1.80	2.22
BL2450	2450	52.70	1.94	2.29
HL2600	2600	38.16	1.93	2.28
BL2600	2600	51.55	2.21	2.34
HL3500	3500	37.01	2.89	2.31
BL3500	3500	52.99	3.20	2.40
HL5200	5200	36.44	4.79	1.96
BL5200	5200	50.70	5.11	2.04
HL5400	5400	35.99	4.91	2.11
BL5400	5400	50.01	5.64	2.22
HL5600	5600	35.22	5.18	2.15
BL5600	5600	49.34	5.85	2.21
HL5800	5800	34.95	5.42	2.13
BL5800	5800	48.54	6.22	2.18

LOWER DETECTION LIMIT: 8mW/kg



5.4 ISOTROPY

**HL5600 MHz**

- Axial isotropy: 0.04 dB
- Hemispherical isotropy: 0.05 dB

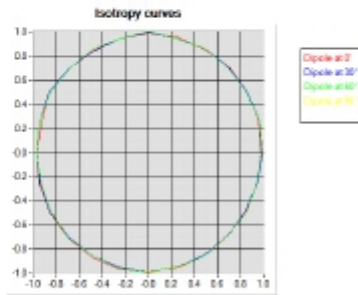

**HL5600 MHz**

- Axial isotropy: 0.04 dB
- Hemispherical isotropy: 0.07 dB

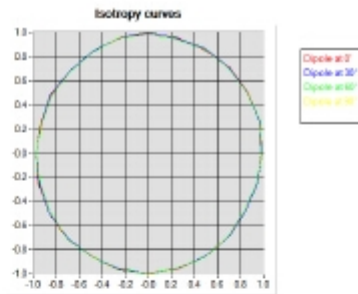

Test Report	15071166-FCC-H
Page	120 of 166



**COMOSAR E-FIELD PROBE CALIBRATION REPORT**

Ref: ACR.265.1.15.SATU.A

**HL5600 MHz**

- Axial isotropy: 0.06 dB
- Hemispherical isotropy: 0.10 dB

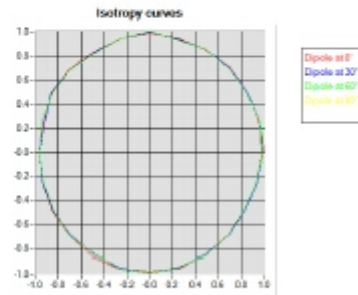





## 6 LIST OF EQUIPMENT

Equipment Summary Sheet				
Equipment Description	Manufacturer / Model	Identification No.	Current Calibration Date	Next Calibration Date
Flat Phantom	MVG	SN-20/09-SAM71	Validated. No cal required.	Validated. No cal required.
COMOSAR Test Bench	Version 3	NA	Validated. No cal required.	Validated. No cal required.
Network Analyzer	Rhode & Schwarz ZVA	SN100132	02/2013	02/2016
Reference Probe	MVG	EP 94 SN 37/08	10/2014	10/2015
Multimeter	Keithley 2000	1188656	12/2013	12/2016
Signal Generator	Agilent E4438C	MY49070581	12/2013	12/2016
Amplifier	Aethercomm	SN 046	Characterized prior to test. No cal required.	Characterized prior to test. No cal required.
Power Meter	HP E4418A	US38261498	12/2013	12/2016
Power Sensor	HP ECP-E26A	US37181460	12/2013	12/2016
Directional Coupler	Narda 4216-20	01386	Characterized prior to test. No cal required.	Characterized prior to test. No cal required.
Waveguide	Mega Industries	069Y7-158-13-712	Validated. No cal required.	Validated. No cal required.
Waveguide Transition	Mega Industries	069Y7-158-13-701	Validated. No cal required.	Validated. No cal required.
Waveguide Termination	Mega Industries	069Y7-158-13-701	Validated. No cal required.	Validated. No cal required.
Temperature / Humidity Sensor	Control Company	11-661-9	8/2012	8/2015