

Letter of acknowledgement

SPECIFICATION FOR APPROVAL

Customer: CUSTOMER:	Refined crafting
Customer Material Number: CUST P/N:	
Sound Material Number: FINE P/N:	G50 * 0.8-20.5-0.15 * 24P-10 T-6. 5UH-L30MM + BJ
Product model: DESC:	Φ 50 MMX0.8MM
Date: DATE:	2024/10/21
Version: Version:	A.0

Drafting PREPARED BY	Audit CHECKED BY	Approval APPROVED BY	Customer acknowledgement CUSTOMER APPROVE
He Licheng	Ma Li	But it can be clear	

Dongguan Yinze Electronic Technology Co., Ltd

Factory address: No. 901, Building 2, Xinghan Road (Chuangfu Central City), Chashan
Town, Dongguan City

But clear TEL: 18617251159

SPECIFICATION

Product model: DESC	G50 * 0.8-20.5-0.15 * 24P-10 T-6. 5UH-L30MM + BJ	Version Rev: A.0	Customer CUST:	Refined crafting
			CUST P/N:	

一、Dimensions DIMENSION: (mm)

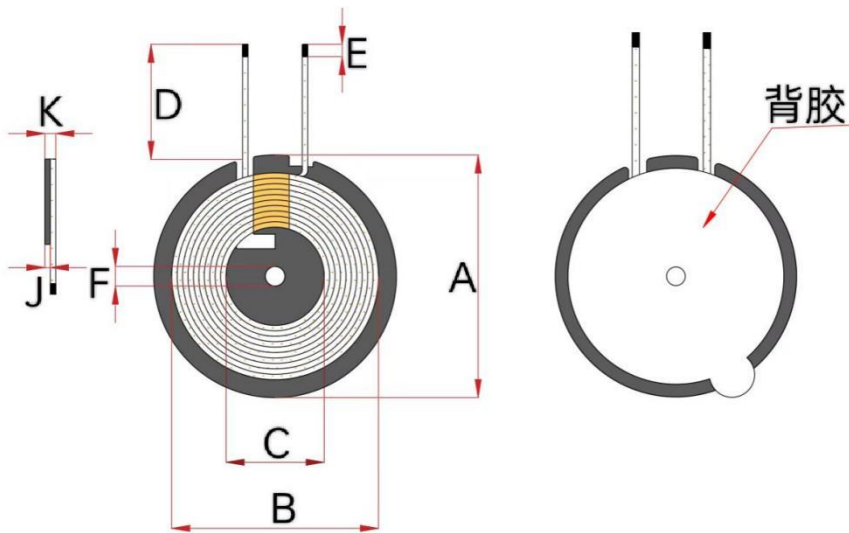

A	50±0.5
B	40.5±0.5
C	20.5±0.5
D	30 ±2
E	3±2
F	5.3±0.2
K	2.3±0.1
J	0.8±0.05
I	

2. Schematic diagram SCHEMATIC D IAGRAM:

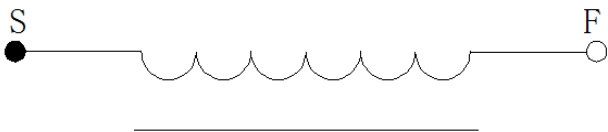

Note:
 1. Cross-out lines;
 2. The coil is attached with a 50mm double-slot magnetic sheet, the size of the magnetic sheet is 50 ± 0.5 mm, and the thickness is 0.8 ± 0.05 mm.
 3. Apply adhesive backing to the back of the magnetic sheet

三、Winding parameters Winding Spec ification:

Serial number NO.	Terminal TERMINAL	Wire diameter WIRE	Number of turns Turns	Winding direction Winding Direction
1	S-F	Silk wrapped wire 0.15 * 24 P	10TS	CCW

4. Electrical characteristics ELECTRICAL CHARA CTERISTICS:

TEMPERATURE TEMPERATURE: 25 ± 10 ° C, Humidity RELATIVE HUMIDITY: 65 ± 20%

Seria	Proje	Terminal	Standard	Test Conditions	Test instrument
-------	-------	----------	----------	-----------------	-----------------

Item number NO.	Item	Terminal	Specification	Test Frequency	Test Equipments
1	IND.	S-F	3.7 uH ± 10% individual coil	100 KH z/1.0 V	LCZ METER 1062B
2	IND.	S-F	6.5 uH ± 10% plus magnetic sheet	100 KH z/1.0 V	LCZ METER 1062B
3	DCR	S-F	≤ 70 mΩ		LCZ METER 502B
Prepared/DATE PREPARED BY/DATE				审评/日 CHECKED BY/DATE	
He Licheng 2024.10.21					