

RF Test Report

Applicant : AcSiP Technology Corporation

Product Name : Wi-Fi 6 (1x1) 802.11a/b/g/n/ac/ax + BT5.2 Combo IoT Module

Trade Name : AcSiP

Model Number : AI7933CLD

Applicable Standard : FCC 47 CFR PART 15 SUBPART E
ANSI C63.10:2013

Received Date : Jul. 08, 2022

Test Period : Jul. 21 ~ Jul. 23, 2022

Issued Date : Aug. 09, 2022

Issued by

A Test Lab Techno Corp.
No. 140-1, Changan Street, Bade District,
Taoyuan City 334025, Taiwan (R.O.C.)
Tel : +886-3-2710188 / Fax : +886-3-2710190



Taiwan Accreditation Foundation accreditation number: 1330
Frequency Range : 9 kHz to 40 GHz
Test Firm MRA designation number: TW0010

Note:

1. The test results are valid only for samples provided by customers and under the test conditions described in this report.
2. This report shall not be reproduced except in full, without the written approval of A Test Lab Technology Corporation.
3. The relevant information is provided by customers in this test report. According to the correctness, appropriateness or completeness of the information provided by the customer, if there is any doubt or error in the information which affects the validity of the test results, the laboratory does not take the responsibility.

Revision History

Rev.	Issued Date	Revisions	Revised By
00	Aug. 04, 2022	Initial Issue	Snow Wang
01	Aug. 09, 2022	Update chapter 3.4 (P.13)	Snow Wang

Verification of Compliance

Applicant : AcSiP Technology Corporation

Product Name : Wi-Fi 6 (1x1) 802.11a/b/g/n/ac/ax + BT5.2 Combo IoT Module

Trade Name : AcSiP

Model Number : AI7933CLD

FCC ID : 2ADWC-AI7933CLD

Applicable Standard : FCC 47 CFR PART 15 SUBPART E
ANSI C63.10:2013

Test Result : Complied

Performing Lab. : A Test Lab Techno Corp.
No. 140-1, Changan Street, Bade District,
Taoyuan City 334025, Taiwan (R.O.C.)
Tel : +886-3-2710188 / Fax : +886-3-2710190
Taiwan Accreditation Foundation accreditation number: 1330



A Test Lab Techno Corp. tested the above equipment in accordance with the requirements set forth in the above standards. All indications of Pass/Fail in this report are opinions expressed by A Test Lab Techno Corp. based on interpretations and/or observations of test results. The test results show that the equipment tested is capable of demonstrating compliance with the requirements as documented in this report.

Approved By :

(Kai Yu Yang)

TABLE OF CONTENTS

1	General Information	5
	1.1. Summary of Test Result.....	5
	1.2. Measurement Uncertainty.....	6
2	EUT Description	7
3	Test Methodology.....	9
	3.1. Mode of Operation.....	9
	3.2. EUT Test Step.....	11
	3.3. Configuration of Test System Details	11
	3.4. Test Instruments	12
	3.5. Test Site Environment.....	14
4	Measurement Procedure.....	15
	4.1. AC Power Conducted Emission Measurement	15
	4.2. Transmitter Radiated Emissions Measurement.....	17
	4.3. Maximum Conducted Output Power Measurement.....	22
	4.4. 26 dB RF Bandwidth Measurement & 99 % Occupied Bandwidth Measurement	23
	4.5. 6 dB RF Bandwidth Measurement	24
	4.6. Maximum Power Spectral Density Measurement	25
	4.7. Automatically discontinue transmission.....	27
	4.8. Antenna Requirement.....	27
5	Test Results.....	28
	5.1 Conducted Emission	28
	5.2 Radiated Emission Measurement.....	30
	5.3 Conducted Test Results.....	138

Appendix A. Test Setup Photographs

1 General Information

1.1. Summary of Test Result

Standard	Item	Result	Remark
15.407(b)(9) 15.207	AC Power Conducted Emission	PASS	---
15.407(b) 15.205 / 15.209	Transmitter Radiated Emissions	PASS	---
15.407(a)	Maximum Conducted Output Power	PASS	---
15.407(a)	26 dB RF Bandwidth & 99 % Occupied Bandwidth	Reference	---
15.407(e)	6 dB RF Bandwidth	PASS	---
15.407(a)	Maximum Power Spectral Density	PASS	---
15.407(c)	Automatically discontinue transmission	PASS	---
15.407(a) 15.203	Antenna Requirement	PASS	---

Decision Rule

- Uncertainty is not included.
- Uncertainty is included.

Standard	Description
CFR47, Part 15, Subpart C	Intentional Radiators
CFR47, Part 15, Subpart E	Unlicensed National Information Infrastructure Devices
ANSI C63. 10: 2013	American National Standard of Procedures for Compliance Testing of Unlicensed Wireless Devices
KDB789033: D02	Guidelines for Compliance Testing of Unlicensed National Information Infrastructure (U-NII) Devices Part 15, Subpart E
KDB 662911 D01 v02r01	Emissions Testing of Transmitters with Multiple Outputs in the Same Band (e.g., MIMO, Smart Antenna, etc)

1.2. Measurement Uncertainty

Test Item	Frequency Range	Uncertainty
Conducted Emission	150 kHz ~ 30 MHz	2.7 dB
Radiated Emission	9 kHz ~ 30 MHz	2.2 dB
	30 MHz ~ 1000 MHz	5.1 dB
	1000 MHz ~ 18000 MHz	5.2 dB
	18000 MHz ~ 26500 MHz	4.6 dB
	26500 MHz ~ 40000 MHz	4.6 dB
Conducted Output Power		1.1 dB
RF Bandwidth		4.7 %
Power Spectral Density		1.1 dB
Frequency Stability		1.3×10^{-7}
Duty Cycle		1.1 %
Time Occupancy		1.5 %

2 EUT Description

Applicant	AcSiP Technology Corporation 9F, No. 242, Bo'ai St., Shulin Dist 23805 New Taipei Taiwan				
Product Name	Wi-Fi 6 (1x1) 802.11a/b/g/n/ac/ax + BT5.2 Combo IoT Module				
Trade Name	AcSiP				
Model Number	AI7933CLD				
FCC ID	2ADWC-AI7933CLD				
Operate Frequency	Frequency Band		Frequency Range (MHz)	Number of Channels	
	IEEE 802.11a	U-NII Band 1	5180 – 5240	4	
		U-NII Band 3	5745 – 5825	5	
	IEEE 802.11n 5 GHz 20 MHz / IEEE 802.11ac 20 MHz IEEE 802.11ax 20 MHz	U-NII Band 1	5180 – 5240	4	
U-NII Band 3		5745 – 5825	5		
Modulation Type	OFDM / OFDMA				
Antenna information	Antenna	Model	Type	Max. Gain (dBi)	
	Antenna-1	IAHA202205004	PCB Dipole Antenna	5150 - 5250	4.99
				5725 - 5850	4.75
	Antenna-2	IAHA202205005	FPC Dipole Antenna	5150 - 5250	3.49
5725 - 5850				4.36	
Antenna Delivery	See section 3.1				
Operate Temp. Range	0 ~ +60 °C				
EUT Power Rating	DC 5 V				

Frequency Band		RF Output Power (W)
IEEE 802.11a	U-NII Band 1	0.115
	U-NII Band 3	0.110
IEEE 802.11n 5 GHz 20 MHz	U-NII Band 1	0.087
	U-NII Band 3	0.085
IEEE 802.11ac 5 GHz 20 MHz	U-NII Band 1	0.086
	U-NII Band 3	0.085
IEEE 802.11ax 20 MHz	U-NII Band 1	0.087
	U-NII Band 3	0.084

Equipment Type		
Outdoor access point	point-to-point	---
	point-to-multipoint	---
Indoor access point		---
Fixed point-to-point access points		---
Client devices		V

3 Test Methodology

3.1. Mode of Operation

Decision of Test ATL has verified the construction and function in typical operation. All the test modes were carried out with the EUT in normal operation, which was shown in this test report and defined as:

Pre-Test Mode
Mode 1: IEEE 802.11a Continuous TX Mode
Mode 2: IEEE 802.11n 5 GHz 20 MHz Continuous TX Mode
Mode 3: IEEE 802.11ac 20 MHz Continuous TX Mode
Mode 4: IEEE 802.11ax 20 MHz Continuous TX Mode

Final-Test Mode
Mode 1: IEEE 802.11a Continuous TX Mode
Mode 2: IEEE 802.11n 5 GHz 20 MHz Continuous TX Mode

Software used to control the EUT for staying in continuous transmitting mode was programmed. After verification, all tests were carried out with the worst case test modes.

Note 1: Investigation has been done on all the possible configurations for searching the worst cases (HT20 covers VHT20/ HE20). The table is a list of the test modes show in this test report.

Note 2: 802.11 ax only support full RU.

Test Mode	Chain 0
Mode 1	V
Mode 2	V
Mode 3	V
Mode 4	V

Test Mode	Antenna Delivery	Data Rate (Mbps)	Band	Test Channel
Mode 1	1TX	6	U-NII Band 1	36, 40, 48
			U-NII Band 3	149, 157, 165
Mode 2	1TX	6.5	U-NII Band 1	36, 40, 48
			U-NII Band 3	149, 157, 165
Mode 3	1TX	6.5	U-NII Band 1	36, 40, 48
			U-NII Band 3	149, 157, 165
Mode 4	1TX	MCS0	U-NII Band 1	36, 40, 48
			U-NII Band 3	149, 157, 165

Duty cycle

Test Mode	Frequency (MHz)	on time (ms)	on+off time (ms)	Duty cycle	Duty Factor (dB)	1/T Minimum VBW (kHz)
Mode 1	5180	2.720	2.990	0.910	0.411	0.368
Mode 2	5180	2.550	2.840	0.898	0.468	0.392

Duty Cycle Graphs

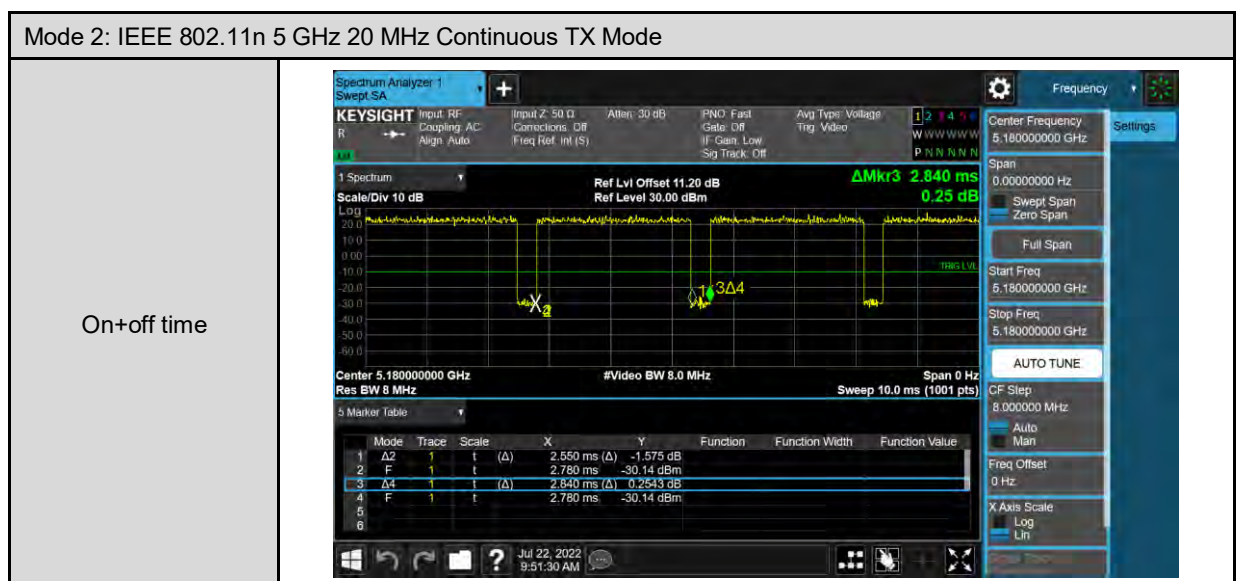
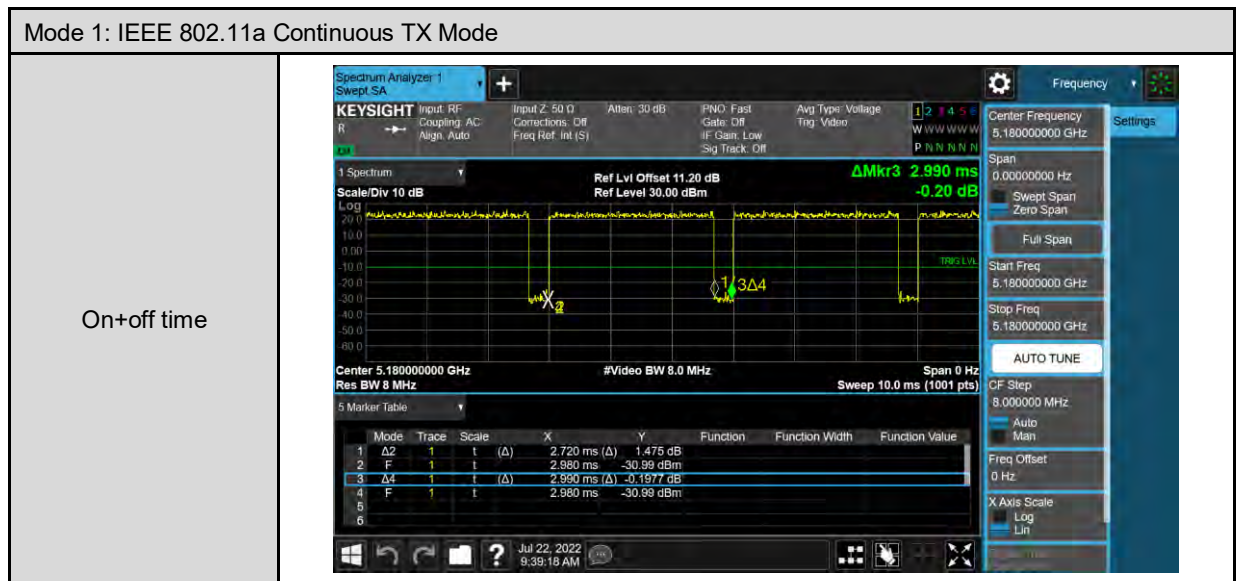

3.2. EUT Test Step

The EUT is operated in the engineering mode to fix the TX frequency for the purposes of measurement. According to its specifications, the EUT must comply with the requirements of Section 15.407 under the FCC Rules Part 15 Subpart E.

1.	Setup the EUT shown on "Configuration of Test System Details".
2.	Turn on the power of all equipment.
3.	Turn on TX function.
4.	EUT run test program.

3.3. Configuration of Test System Details

Radiated Emission & Conduction Emission

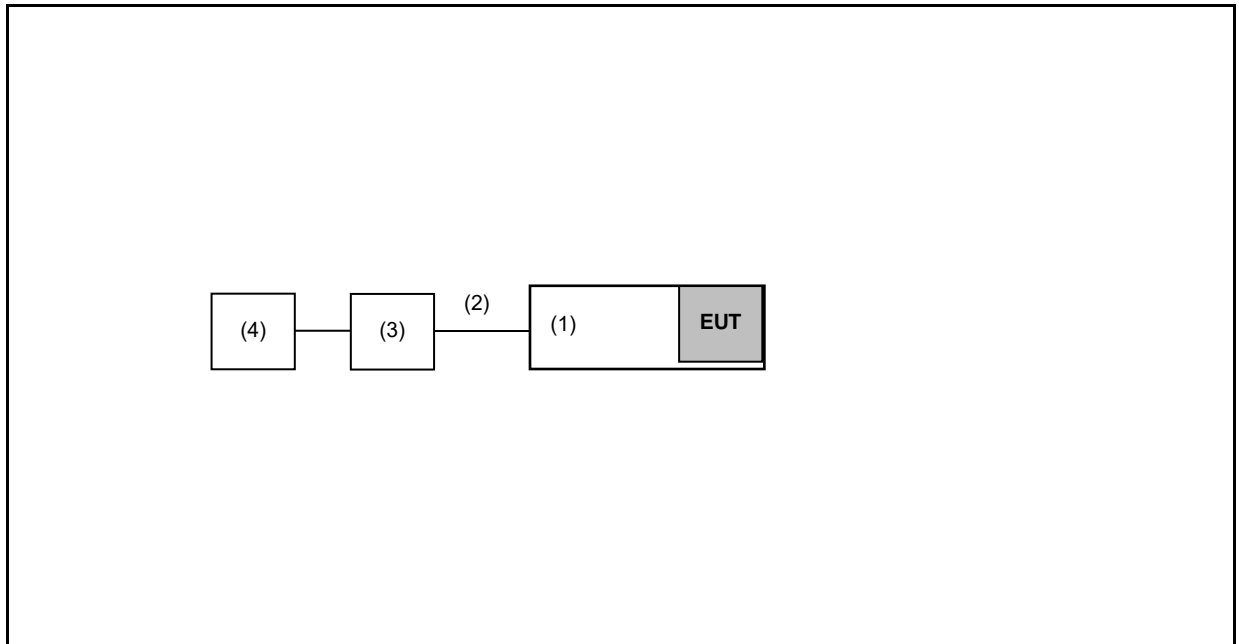

Devices Description					
	Product	Manufacturer	Model Number	Serial Number	Power Cord
(1)	Fixture	AcSiP	EK-AI7933CLD	---	---
(2)	USB Cable	LG	EAD63769703	---	---
(3)	Notebook	acer	N19C1	---	---
(4)	AC Adapter	chiicony	A18-045N2A	---	Non-Shielded, 1.5 m

3.4. Test Instruments

For Conducted Emission
 Test Period: Jul. 23, 2022
 Testing Engineer: Chi Chang

Use	Equipment	Manufacturer	Model Number	Serial Number	Cal. Date	Cal. Period
<input checked="" type="checkbox"/>	Test Receiver	R&S	ESCI	100367	May 19, 2022	1 year
<input type="checkbox"/>	Test Receiver	R&S	ESCI	100722	Nov. 02, 2021	1 year
<input type="checkbox"/>	Test Receiver	R&S	ESCI	101000	Nov. 26, 2021	1 year
<input checked="" type="checkbox"/>	LISN	R&S	ENV216	101040	Apr. 06, 2022	1 year
<input type="checkbox"/>	LISN	R&S	ENV216	101041	Apr. 15, 2022	1 year
<input checked="" type="checkbox"/>	RF Cable	Woken	00100D1380194M	TE-02-03	May 27, 2022	1 year
<input checked="" type="checkbox"/>	Software	EZ EMC	1.1.4.3	N/A	N.C.R.	---

For Conducted
 Test Period: Jul. 22 ~ Jul. 23, 2022
 Testing Engineer: Brian Lin

Use	Equipment	Manufacturer	Model Number	Serial Number	Cal. Date	Cal. Period
<input type="checkbox"/>	Power Sensor	Anritsu	MA2411B	1126022	Sep. 03, 2021	1 year
<input type="checkbox"/>	Power Meter	Anritsu	ML2495A	1135009	Sep. 03, 2021	1 year
<input checked="" type="checkbox"/>	Power Sensor	Agilent	N1921A	MY45241957	Dec. 06, 2021	1 year
<input checked="" type="checkbox"/>	Power Meter	Agilent	N1911A	MY45101619	Dec. 06, 2021	1 year
<input checked="" type="checkbox"/>	Spectrum Analyzer (10 Hz~26.5 GHz)	Keysight	N9010B	MY59071418	Mar. 16, 2022	1 year
<input type="checkbox"/>	Spectrum Analyzer (9 kHz~26.5 GHz)	Agilent	N9010A	MY48030518	Jul. 23, 2021	1 year
<input type="checkbox"/>	Spectrum Analyzer (20 Hz~26.5 GHz)	Agilent	N9020A	US47520902	Sep. 09, 2021	1 year
<input type="checkbox"/>	Spectrum Analyzer (3 Hz~50 GHz)	Agilent	N9030A	MY53120541	Jan. 05, 2022	1 year
<input type="checkbox"/>	Temperature & Humidity Chamber	TAICHY	MHU-225LA	980729	Mar. 28, 2022	1 year
<input type="checkbox"/>	Signal Generator	Keysight	N5182B	MY53052569	Apr. 16, 2022	1 year
<input type="checkbox"/>	Signal Generator	Keysight	N5182BX07	MY59360221	Apr. 16, 2022	1 year
<input type="checkbox"/>	Bluetooth Tester	R&S	CBT	100350	Mar. 17, 2021	2 years
<input type="checkbox"/>	Wireless Connectivity Tester	R&S	CMW270	102208	Jun. 02, 2021	1 year
<input type="checkbox"/>	Power Supply	KEITHLEY	2303	4045290	Jan. 19, 2022	1 year
<input type="checkbox"/>	RF Communication Test Set	HP	8920A	3344A03297	Aug. 10, 2021	1 year

Note: N.C.R. = No Calibration Request.

For Radiated Emissions

Test Period: Jul. 21, 2022

Testing Engineer: Hung Chou, Marc Yeh , Amy Wen

Radiation test sites		Semi Anechoic Room				
Use	Equipment	Manufacturer	Model Number	Serial Number	Cal. Date	Cal. Period
<input type="checkbox"/>	Spectrum Analyzer (10 Hz~44 GHz)	Keysight	N9010A	MY52221312	Jan. 13, 2022	1 year
<input type="checkbox"/>	Spectrum Analyzer (3 Hz~50 GHz)	Agilent	N9030A	MY53120541	Jan. 05, 2022	1 year
<input checked="" type="checkbox"/>	Spectrum Analyzer (2 Hz~50 GHz)	Keysight	N9030B	MY57143537	Apr. 14, 2022	1 year
<input type="checkbox"/>	Spectrum Analyzer (10 Hz~44 GHz)	Keysight	N9020B	MY60112363	Feb. 27, 2022	1 year
<input checked="" type="checkbox"/>	Amplifier (1 GHz~26.5 GHz)	Agilent	8449B	3008A02237	Oct. 21, 2021	1 year
<input checked="" type="checkbox"/>	Amplifier (100 kHz~1.3 GHz)	Agilent	8447D	2944A11119	Jan. 14, 2022	1 year
<input type="checkbox"/>	Amplifier (100 kHz~1.3 GHz)	Agilent	8447D	2944A10961	Jul. 06, 2021	1 year
<input type="checkbox"/>	Broadband Amplifier (100 kHz~1 GHz)	Titan	T0910E00014330 A1F	001	Jul. 23, 2021	1 year
<input type="checkbox"/>	Amplifier (1 GHz~26.5 GHz)	Agilent	8449B	3008A02237	Oct. 21, 2021	1 year
<input type="checkbox"/>	Broadband Amplifier (1 GHz~26.5 GHz)	Titan	T0912E01263025 A1F	002	Jul. 26, 2021	1 year
<input checked="" type="checkbox"/>	Preamplifier (26.5 GHz~40 GHz)	EMCI	EMC2654045	980028	Aug. 19, 2021	1 year
<input checked="" type="checkbox"/>	Loop Antenna (9 kHz~30 MHz)	COM-POWER CORPORATION	AL-130	121014	Mar. 28, 2022	1 year
<input type="checkbox"/>	Active Loop Antenna (9 kHz~30 MHz)	Schwarzbeck Mess-Elektronik	FMZB 1513-60	1513-60-031	Feb. 17, 2022	1 year
<input type="checkbox"/>	Trilog Broadband Antenna (30 kHz~1 GHz)	Schwarzbeck Mess-Elektronik	VULB9168	01146	Jul. 19, 2021	1 year
<input checked="" type="checkbox"/>	Trilog Broadband Antenna (30 kHz~1 GHz)	Schwarzbeck Mess-Elektronik	VULB9168	416	Nov. 17, 2021	1 year
<input type="checkbox"/>	Broadband Horn Antenna (1 GHz~18 GHz)	Schwarzbeck Mess-Elektronik	9120D	02207	Jul. 09, 2021	1 year
<input checked="" type="checkbox"/>	Broadband Horn Antenna (1 GHz~18 GHz)	Schwarzbeck Mess-Elektronik	9120D	9120D-550	Aug. 24, 2021	1 year
<input checked="" type="checkbox"/>	Broadband Horn Antenna (18 GHz~40 GHz)	Schwarzbeck Mess-Elektronik	9170	9170-320	Aug. 24, 2021	1 year
<input type="checkbox"/>	Horn Antenna (18 GHz~40 GHz)	ETS	3116	00086467	Dec. 03, 2021	1 year

Note: N.C.R. = No Calibration Request.

Radiation test sites		Semi Anechoic Room				
Use	Equipment	Manufacturer	Model Number	Serial Number	Cal. Date	Cal. Period
<input type="checkbox"/>	RF Cable	EMCI	EMC104-N-N-6000	TE01-1	Feb. 18, 2022	1 year
<input type="checkbox"/>	Microwave Cable	EMCI	EMC104-SM-SM-13000	170814	Feb. 18, 2022	1 year
<input type="checkbox"/>	Microwave Cable	EMCI	EMC102-KM-KM-14000	151001	Feb. 18, 2022	1 year
<input checked="" type="checkbox"/>	Coaxial Cable	Titan	T0710AT327A10A100	J11005	Aug. 06, 2021	1 year
<input checked="" type="checkbox"/>	Coaxial Cable	Titan	T0710AT327A10A900	J11004	Aug. 06, 2021	1 year
<input checked="" type="checkbox"/>	Coaxial Cable	Titan	CFD400NL-LW	001	Aug. 06, 2021	1 year
<input type="checkbox"/>	Bluetooth Tester	R&S	CBT	100350	Mar. 17, 2021	2 years
<input type="checkbox"/>	Wireless Connectivity Tester	R&S	CMW270	102208	Jun. 02, 2021	1 year
<input type="checkbox"/>	Power Supply	KEITHLEY	2303	4045290	Jan. 19, 2022	1 year
<input checked="" type="checkbox"/>	Software	EZ EMC	1.1.4.4	N/A	N.C.R.	---

Note: N.C.R. = No Calibration Request.

3.5. Test Site Environment

Items	Required (IEC 60068-1)	Actual
Temperature (°C)	15-35	20-30
Humidity (%RH)	25-75	45-75

4 Measurement Procedure

4.1. AC Power Conducted Emission Measurement

■ Limit

Frequency (MHz)	Quasi-peak	Average
0.15 - 0.5	66 to 56	56 to 46
0.50 - 5.0	56	46
5.0 - 30.0	60	50

■ Test Setup

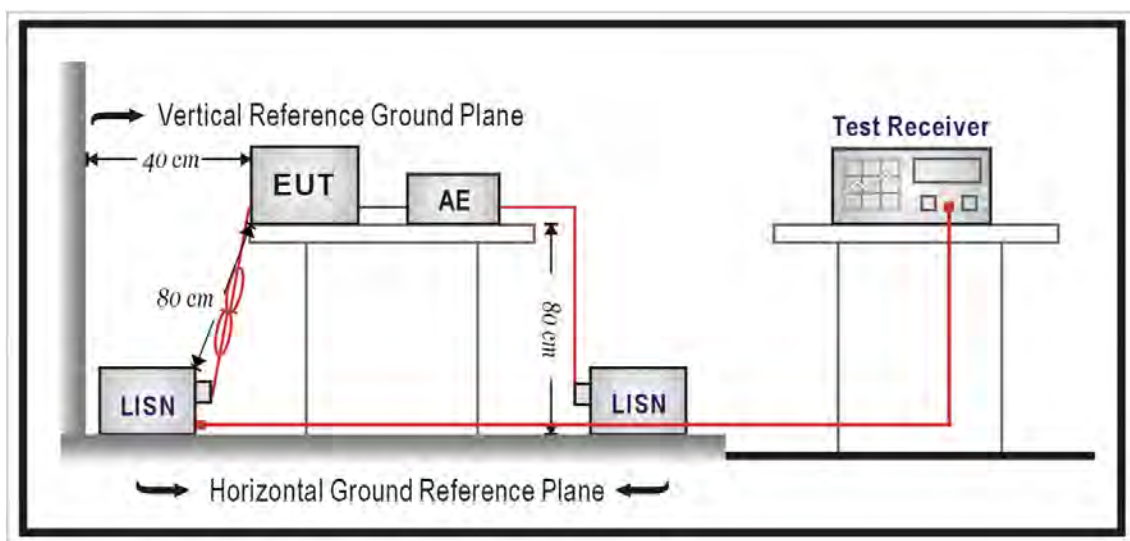

■ Test Procedure

The EUT and simulators are connected to the main power through a line impedance stabilization network (L.I.S.N.). This provides a $50 \Omega // 50 \mu\text{H}$ coupling impedance for the measuring equipment. The peripheral devices are also connected to the main power through a LISN that provides a $50 \Omega // 50 \mu\text{H}$ coupling impedance with 50 ohm termination.

Tabletop device shall be placed on a non-conducting platform, of nominal size 1 m by 1.5 m, raised 80 cm above the reference ground plane. The wall of screened room shall be located 40 cm to the rear of the EUT. Other surfaces of tabletop or floor standing EUT shall be at least 80 cm from any other ground conducting surface including one or more LISNs. For floor-standing device shall be placed under the EUT with a 12 mm insulating material.

Conducted emissions were investigated over the frequency range from 0.15 MHz to 30 MHz using a resolution bandwidth of 9 kHz. The equipment under test (EUT) shall be meet the limits in section 4.1, as applicable, including the average limit and the quasi-peak limit when using respectively, an average detector and quasi-peak detector measured in accordance with the methods described of related standard. When all of peak value were complied with quasi-peak and average limit from 150 kHz to 30 MHz then quasi-peak and average measurement was unnecessary.

The AMN shall be placed 0.8 m from the boundary of the unit under test and bonded to a ground reference plane for AMNs mounted on top of the ground reference plane. This distance is between the closest points of the AMN and the EUT. All other units of the EUT and associated equipment shall be at least 0.8 m from the AMN. If the mains power cable is longer than 1 m then the cable shall be folded back and forth at the centre of the lead to form a bundle no longer than 0.4 m. All of interconnecting cables that hang closer than 40 cm to the ground plane shall be folded back and forth in the center forming a bundle 30 cm to 40 cm long. All of EUT and AE shall be separate place more than 0.1 m. All 50Ω ports of the LISN shall be resistively terminated into 50Ω loads when not connected to the measuring instrument.

If the reading of the measuring receiver shows fluctuations close to the limit, the reading shall be observed for at least 15 s at each measurement frequency; the higher reading shall be recorded with the exception of any brief isolated high reading which shall be ignored

4.2. Transmitter Radiated Emissions Measurement

■ Limit

(1) Undesirable emission limits. Except as shown in paragraph (b)(9) of this section, the maximum emissions outside of the frequency bands of operation shall be attenuated in accordance with the following limits:

(a) For transmitters operating in the 5.15-5.25 GHz band: All emissions outside of the 5.15-5.35 GHz band shall not exceed an e.i.r.p. of -27 dBm/MHz.

(b) For transmitters operating in the 5.25-5.35 GHz band: All emissions outside of the 5.15-5.35 GHz band shall not exceed an e.i.r.p. of -27 dBm/MHz.

(c) For transmitters operating in the 5.47-5.725 GHz band: All emissions outside of the 5.47-5.725 GHz band shall not exceed an e.i.r.p. of -27 dBm/MHz.

(d) For transmitters operating in the 5.725-5.85 GHz band:

(i) All emissions shall be limited to a level of -27 dBm/MHz at 75 MHz or more above or below the band edge increasing linearly to 10 dBm/MHz at 25 MHz above or below the band edge, and from 25 MHz above or below the band edge increasing linearly to a level of 15.6 dBm/MHz at 5 MHz above or below the band edge, and from 5 MHz above or below the band edge increasing linearly to a level of 27 dBm/MHz at the band edge.

EIRP (dBm)	Field Strength at 3 m (dBuV/m)
-27	68.3

(2) Limits of Radiated Emission Measurement

Emissions radiated outside of the specified bands, shall be according to the general radiated limits in 15.209 as following:

Frequency Range (MHz)	Field Strength (microvolts/meter)	Measurement Distance (meters)
0.009 ~ 0.490	2400/F(kHz)	300
0.490 ~ 1.705	24000/F(kHz)	30
1.705 ~ 30.0	30	30
30 ~ 88	10	3
88 ~ 216	150	3
216 ~ 960	200	3
Above 960	500	3

Note: 1. The lower limit shall apply at the transition frequencies.

2. Emission level (dBuV/m) = 20 log Emission level (uV/m).

3. As shown in 15.35(b), for frequencies above 1000 MHz, the field strength limits are based on average detector, however, the peak field strength of any emission shall not exceed the maximum permitted average limits, specified above by more than 20 dB under any condition of modulation.

■ Setup

9 kHz ~ 30 MHz

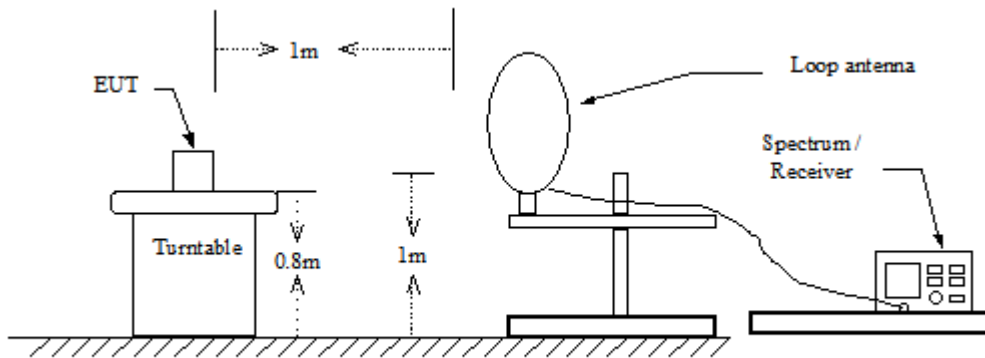

30 MHz ~ 1 GHz

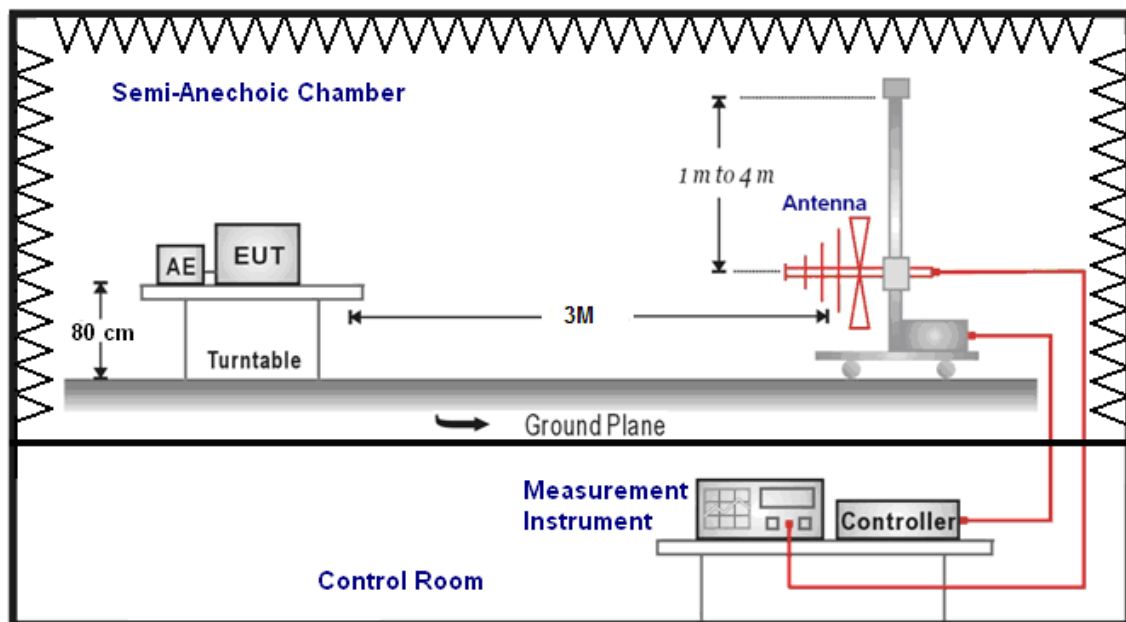

Above 1 GHz

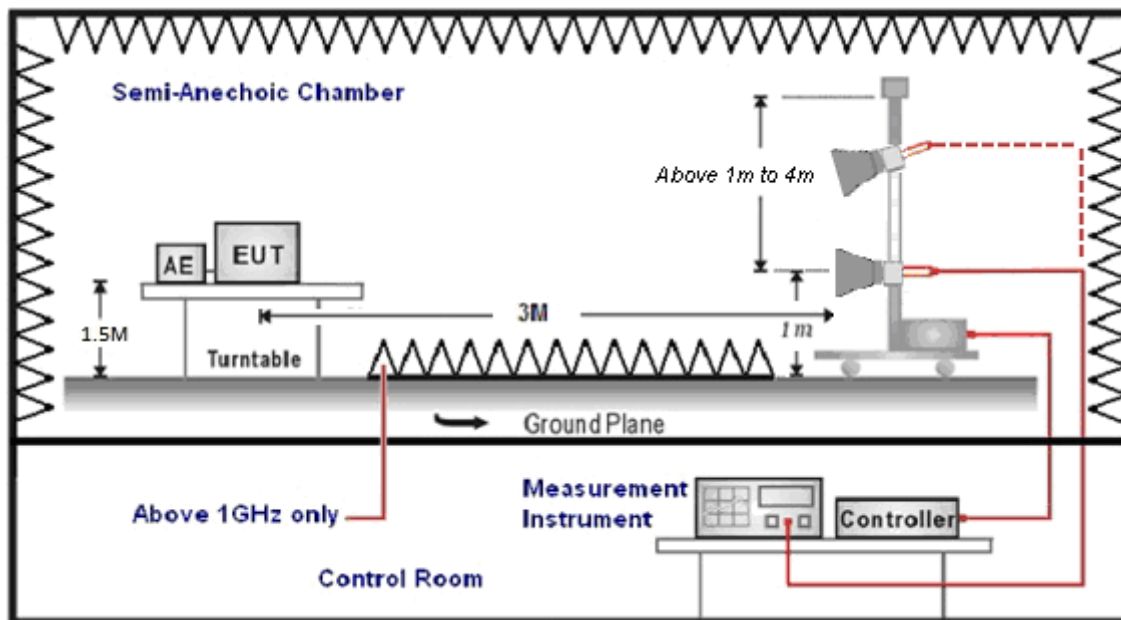

■ Test Procedure

Final radiation measurements were made on a three-meter, Semi Anechoic Chamber. The EUT system was placed on a nonconductive turntable which is 0.8 or 1.5 meters height (below 1 GHz use 0.8 m turntable / above 1 GHz use 1.5 m turntable), top surface 1.0 x 1.5 meter. The spectrum was examined from 250 MHz to 2.5 GHz in order to cover the whole spectrum below 10th harmonic which could generate from the EUT. During the test, EUT was set to transmit continuously & Measurements spectrum range from 9 kHz to 40 GHz is investigated.

For measurements below 1 GHz the resolution bandwidth is set to 100 kHz for peak detection measurements or 120 kHz for quasi-peak detection measurements. Peak detection is used unless otherwise noted as quasi-peak.

For restricted measurements above 1 GHz the resolution bandwidth is set to 1 MHz, and then the video bandwidth is set to 3 MHz for peak measurements and 10 Hz for average measurements when Duty cycle > 0.98 / 1/T for average measurements when Duty cycle < 0.98.

For out of band measurements above 1 GHz the resolution bandwidth is set to 1 MHz, and then the video bandwidth is set to 3 MHz for peak measurements.

A nonconductive material surrounded the EUT to supporting the EUT for standing on three orthogonal planes. At each condition, the EUT was rotated 360 degrees, and the antenna was raised and lowered from one to four meters to find the maximum emission levels. Measurements were taken using both horizontal and vertical antenna polarization.

SCHWARZBECK MESS-ELEKTRONIK Trilog-Broadband Antenna at 3 Meter and the ETS-Lindgren Double-Ridged Waveguide Horn antenna Schwarzbeck Mess-Elektronik Broadband Horn Antenna was used in frequencies 1 – 40 GHz at a distance of 3 meter. The antenna at an angle toward the source of the emission. All test results were extrapolated to equivalent signal at 3 meters utilizing an inverse linear distance extrapolation Factor (20 dB/decade).

For testing above 1 GHz, the emission level of the EUT in peak mode was 20 dB lower than average limit (that means the emission level in peak mode also complies with the limit in average mode), then testing will be stopped and peak values of EUT will be reported, otherwise, the emissions will be measured in average mode again and reported.

Appropriate preamplifiers were used for improving sensitivity and precautions were taken to avoid overloading or desensitizing the spectrum analyzer. No post – detector video filters were used in the test.

The spectrum analyzer's 6 dB bandwidth was set to 1 MHz, and the analyzer was operated in the peak detection mode, for frequencies both below and up 1 GHz. The average levels were obtained by subtracting the duty cycle correction factor from the peak readings.

The following procedures were used to convert the emission levels measured in decibels referenced to 1 microvolt (dBuV) into field intensity in micro volts per meter (uV/m).

The actual field intensity in decibels referenced to 1 microvolt in to field intensity in micro volts per meter (dBuV/m).

Data of measurement within this frequency range without mark in the table above means the reading of emissions are attenuated more than 20 dB below the permissible limits or the field strength is too small to be measured.

The actual field is intensity in referenced to 1 microvolt per meter (dBuV/m) is determined by algebraically adding the measured reading in dBuV, the antenna factor (dB), and cable loss (dB) and Subtracting the gain of preamplifier (dB) is auto calculate in spectrum analyzer.

(1) $\text{Amplitude (dBuV/m)} = \text{FI (dBuV)} + \text{AF (dBuV)} + \text{CL (dBuV)} - \text{Gain (dB)}$

FI= Reading of the field intensity.

AF= Antenna factor.

CL= Cable loss.

P.S Amplitude is auto calculate in spectrum analyzer.

(2) $\text{Actual Amplitude (dBuV/m)} = \text{Amplitude (dBuV)} - \text{Dis(dB)}$

The FCC specified emission limits were calculated according the EUT operating frequency and by following linear interpolation equations:

(a) For fundamental frequency : Transmitter Output < +30 dBm

(b) For spurious frequency : Spurious emission limits = fundamental emission limit /10

Measuring Instruments and setting

The following table is the setting of spectrum analyzer and receiver.

Spectrum Parameter	Setting
Attenuation	Auto
Start Frequency	1000 MHz
Stop Frequency	40 GHz
RBW/VBW(Emission in restricted band)	1 MHz / 3 MHz for Peak 1 MHz / (1/T) for Average
RBW/VBW(Emission in non-restricted band)	1 MHz / 3 MHz for Peak

4.3. Maximum Conducted Output Power Measurement

■ **Limit**

Frequency Range (MHz)	FCC Maximum Conducted Output Power Limit
	Client
5.150 ~ 5.250 GHz	The lesser of 250 mW (24 dBm)
5.725 ~ 5.850 GHz	The lesser of 1 W (30 dBm)

According FCC KDB 662911 D01 v02r01 – for power measurements on IEEE802.11 devices,

■ **Test Setup**

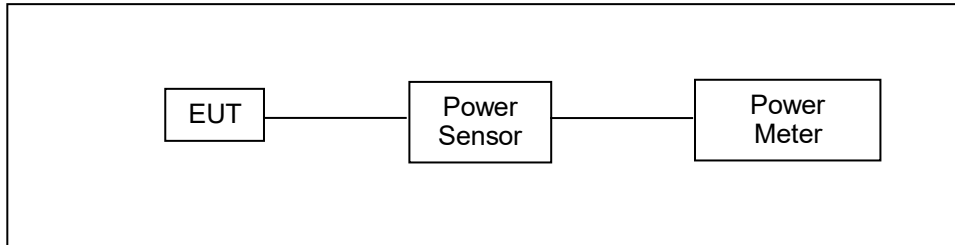

■ **Test Procedure**

The test is performed in accordance with ANSI C63.10:2013 section 12.3.3.2, Guidelines for Compliance Testing of Unlicensed National Information Infrastructure (U-NII) Devices

Section (E) Maximum Conducted Output Power

3. Measurement using a Power Meter (PM)

b) Method PM-G (Measurement using a gated RF average power meter)

4.4. 26 dB RF Bandwidth Measurement & 99 % Occupied Bandwidth Measurement

■ **Limit**

N/A

■ **Test Setup**

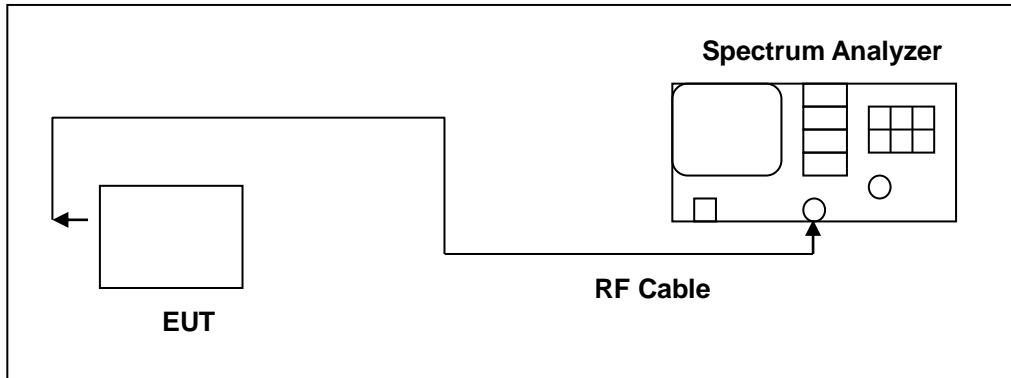

■ **Test Procedure**

The test is performed in accordance with ANSI C63.10:2013 section 12.4, Guidelines for Compliance Testing of Unlicensed National Information Infrastructure (U-NII) Devices - Part 15, Subpart E.

Spectrum Parameter	Setting
Attenuation	Auto
Span Frequency	>26 dB Bandwidth
RBW	Approximately 1 % of the emission bandwidth
VBW	VBW > RBW
Detector	Peak
Trace	Max Hold
Sweep Time	Auto

4.5. 6 dB RF Bandwidth Measurement

- **Limit**

- **6 dB RF Bandwidth**

Systems using digital modulation techniques may operate in the 5725~5850 MHz bands. The minimum 6 dB band-width shall be at least 500 kHz.

- **Test Setup**

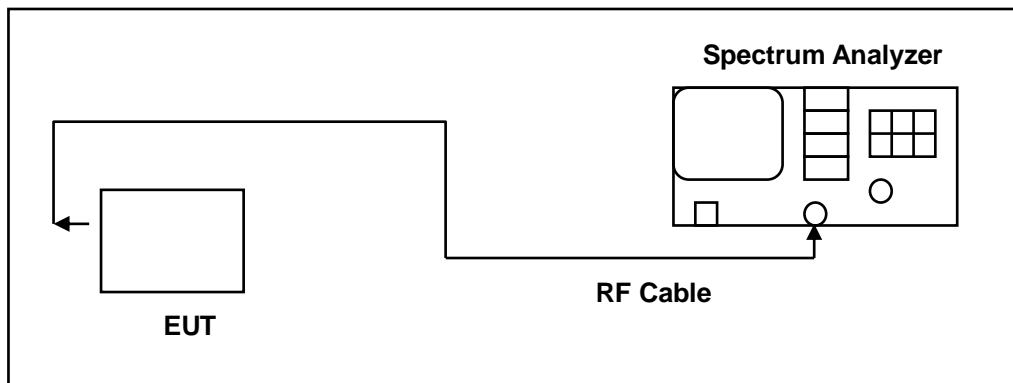

- **Test Procedure**

- **6 dB RF Bandwidth**

The EUT tested to UNII test procedure of ANSI C63.10:2013 section 6.9.2 for compliance to FCC 47CFR 15.407 requirements.

The antenna port of the EUT was connected to the input of a spectrum analyzer. Analyzer RES BW was set to 100 kHz. For each RF output channel investigated, the spectrum analyzer center frequency was set to the channel carrier. A peak output reading was taken, a DISPLAY line was drawn 6 dB lower than peak level. The 6 dB bandwidth was determined from where the channel output spectrum intersected the display line.

The test was performed at 3 channels.

4.6. Maximum Power Spectral Density Measurement

■ **Limit**

Frequency Range (MHz)	FCC Limit
	Client
5.150 ~ 5.250 GHz	11 dBm/MHz
5.725 ~ 5.850 GHz	30 dBm/500 kHz

According FCC KDB 662911 D01 v02r01 – for power spectral density measurements on IEEE802.11 devices,

■ **Test Setup**

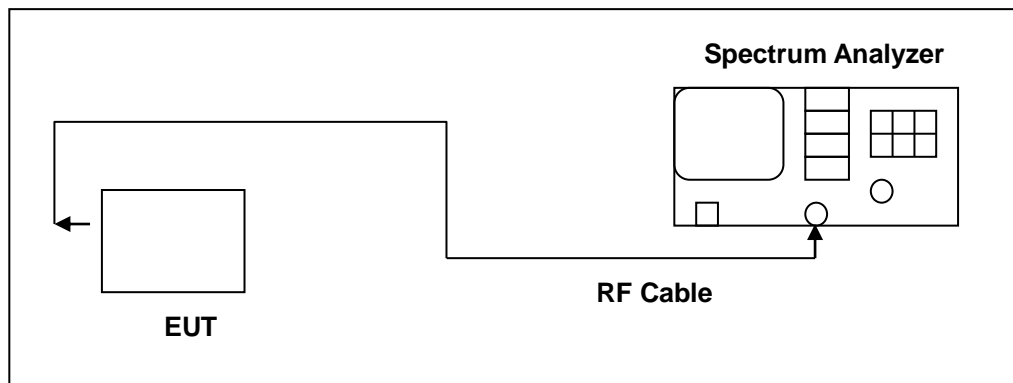

■ **Test Procedure**

The test is performed in accordance with ANSI C63.10:2013 section 12.5, Guidelines for Compliance Testing of Unlicensed National Information Infrastructure (U-NII) Devices - Part 15, Subpart E.

Spectrum Parameter	Setting
Attenuation	Auto
Span Frequency	Encompass the entire emissions bandwidth (EBW) of the signal
RBW	1 MHz (5725 ~ 5850 MHz use 100 kHz)
VBW	3 MHz (5725 ~ 5850 MHz use 300 kHz)
Detector	RMS
Trace	AVERAGE
Sweep Time	Auto
Trace Average	100 times
Note: If measurement bandwidth of Maximum PSD is specified in 500 kHz, add $10 \log(500 \text{ kHz}/100 \text{ kHz})$ to the measured result.	

4.7. Automatically discontinue transmission

The device shall automatically discontinue transmission in case of either absence of information to transmit or operational failure. These provisions are not intended to preclude the transmission of control or signalling information or the use of repetitive codes used by certain digital technologies to complete frame or burst intervals. Applicants shall include in their application for equipment authorization a description of how this requirement is met.

- **Declare**

While the EUT is not transmitting any information, the EUT can automatically discontinue transmission and become standby mode for power saving.

The EUT can detect the controlling signal of ACK message transmitting from remote device and verify whether it shall resend or discontinue transmission.

4.8. Antenna Requirement

- **Limit**

For intentional device, according to 15.203, an intentional radiator shall be designed to ensure that no antenna other than that furnished by the responsible party shall be used with the device.

And According to 15.407 (a), if transmitting antennas of directional gain greater than 6 dBi are used, the power shall be reduced by the amount in dB that the directional gain of the antenna exceeds 6 dBi.

- **Antenna Connector Construction**

See section 2 – antenna information.

5 Test Results

5.1 Conducted Emission

Standard:	FCC Part 15.407	Line:	L1
Test item:	Conducted Emission	Power:	AC 120 V/60 Hz
Mode:	Mode 1		
Description:			

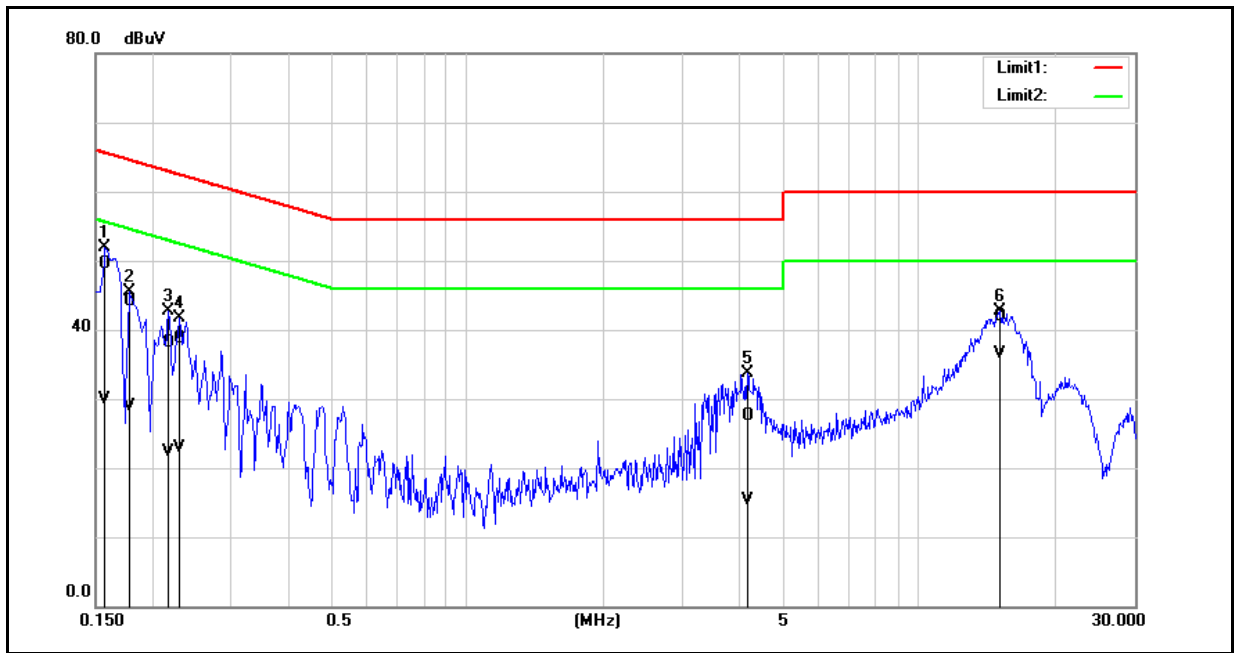

No.	Frequency (MHz)	QP reading (dBuV)	AVG reading (dBuV)	Correction factor (dB)	QP result (dBuV)	AVG result (dBuV)	QP limit (dBuV)	AVG limit (dBuV)	QP margin (dB)	AVG margin (dB)	Remark
1	0.1580	39.90	20.42	9.54	49.44	29.96	65.57	55.57	-16.13	-25.61	Pass
2	0.1780	34.62	19.28	9.54	44.16	28.82	64.58	54.58	-20.42	-25.76	Pass
3	0.2180	28.65	12.80	9.54	38.19	22.34	62.89	52.89	-24.70	-30.55	Pass
4	0.2300	29.16	13.28	9.54	38.70	22.82	62.45	52.45	-23.75	-29.63	Pass
5	4.1700	17.83	5.67	9.67	27.50	15.34	56.00	46.00	-28.50	-30.66	Pass
6	15.1340	32.07	26.65	9.83	41.90	36.48	60.00	50.00	-18.10	-13.52	Pass

Note: 1. Result (dBuV) = Correction factor (dB) + Reading(dBuV).

2. Correction factor (dB) = Cable loss (dB) + L.I.S.N. factor (dB).

Standard:	FCC Part 15.407	Line:	N
Test item:	Conducted Emission	Power:	AC 120 V/60 Hz
Mode:	Mode 1		
Description:			

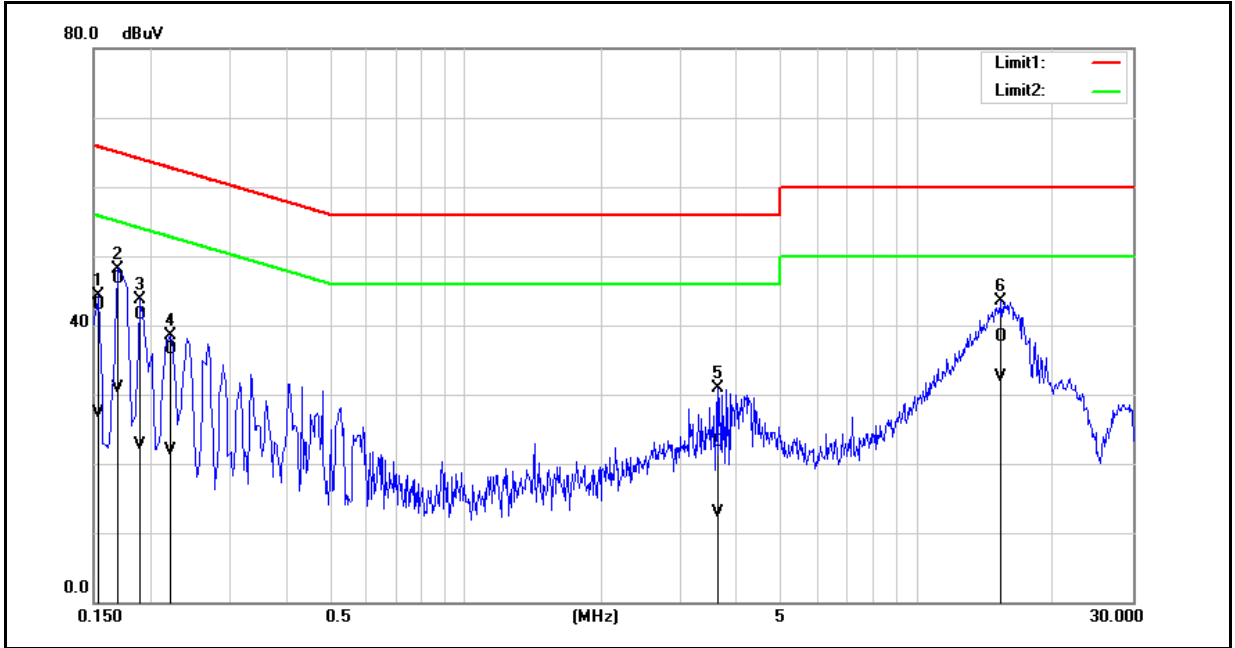

No.	Frequency (MHz)	QP reading (dBuV)	AVG reading (dBuV)	Correction factor (dB)	QP result (dBuV)	AVG result (dBuV)	QP limit (dBuV)	AVG limit (dBuV)	QP margin (dB)	AVG margin (dB)	Remark
1	0.1540	33.32	17.62	9.60	42.92	27.22	65.78	55.78	-22.86	-28.56	Pass
2	0.1700	37.02	21.25	9.60	46.62	30.85	64.96	54.96	-18.34	-24.11	Pass
3	0.1900	31.83	13.17	9.60	41.43	22.77	64.04	54.04	-22.61	-31.27	Pass
4	0.2220	26.84	12.36	9.60	36.44	21.96	62.74	52.74	-26.30	-30.78	Pass
5	3.6180	13.40	3.09	9.72	23.12	12.81	56.00	46.00	-32.88	-33.19	Pass
6	15.3220	28.32	22.57	9.97	38.29	32.54	60.00	50.00	-21.71	-17.46	Pass

Note: 1. Result (dBuV) = Correction factor (dB) + Reading(dBuV).
2. Correction factor (dB) = Cable loss (dB) + L.I.S.N. factor (dB).

5.2 Radiated Emission Measurement

PCB Dipole Antenna

Below 1 GHz

Standard:	FCC Part 15.407	Test Distance:	3 m
Test item:	Radiated Emission		
Frequency:	5745 MHz		
Mode:	Mode 1		
Ant.Polar.:	Horizontal		

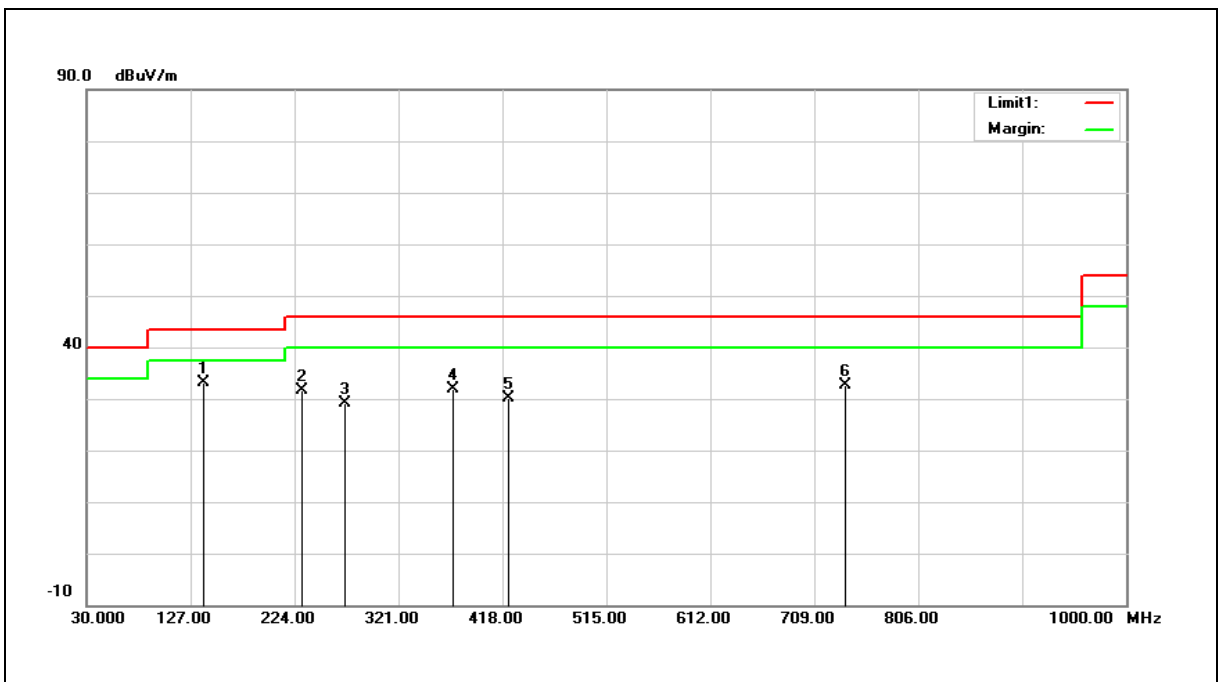

No.	Frequency (MHz)	Reading (dBuV)	Correct Factor (dB/m)	Result (dBuV/m)	Limit (dBuV/m)	Margin (dB)	Remark
1	139.6100	40.74	-7.61	33.13	43.50	-10.37	QP
2	230.7900	41.10	-9.49	31.61	46.00	-14.39	QP
3	270.5600	35.98	-6.94	29.04	46.00	-16.96	QP
4	371.4400	36.66	-4.83	31.83	46.00	-14.17	QP
5	423.8200	33.58	-3.40	30.18	46.00	-15.82	QP
6	738.1000	29.47	3.19	32.66	46.00	-13.34	QP

Note: 1. Result (dBuV/m) = Correct Factor (dB/m) + Reading (dBuV).

2. Correction factor (dB/m) = Antenna Factor (dB/m) + Cable loss (dB) – Pre-Amplifier gain (dB).

3. When the peak results are less than average limit, so not need to evaluate the average.

Standard:	FCC Part 15.407	Test Distance:	3 m
Test item:	Radiated Emission		
Frequency:	5745 MHz		
Mode:	Mode 1		
Ant.Polar.:	Vertical		

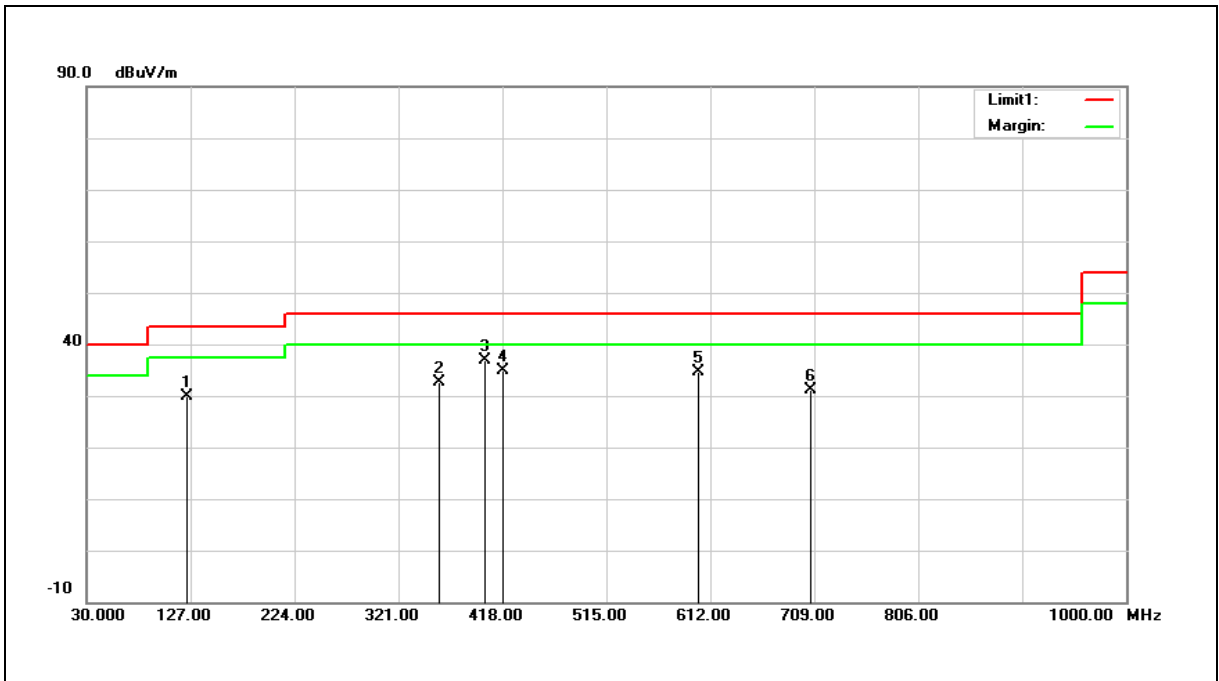

No.	Frequency (MHz)	Reading (dBuV)	Correct Factor (dB/m)	Result (dBuV/m)	Limit (dBuV/m)	Margin (dB)	Remark
1	124.0900	38.96	-9.04	29.92	43.50	-13.58	QP
2	358.8300	37.95	-5.25	32.70	46.00	-13.30	QP
3	401.5100	40.83	-3.85	36.98	46.00	-9.02	QP
4	418.9700	38.44	-3.50	34.94	46.00	-11.06	QP
5	600.3600	33.91	0.65	34.56	46.00	-11.44	QP
6	706.0900	28.68	2.56	31.24	46.00	-14.76	QP

Note:1.Result (dBuV/m) = Correct Factor (dB/m) + Reading(dBuV).

2.Correction factor (dB/m) = Antenna Factor (dB/m) + Cable loss (dB) – Pre-Amplifier gain (dB).

3.When the peak results are less than average limit, so not need to evaluate the average.

Harmonic

Above 1 GHz

Standard:	FCC Part 15.407	Test Distance:	3 m
Test item:	Harmonic		
Frequency:	5180 MHz		
Mode:	Mode 1		
Ant.Polar.:	Horizontal		

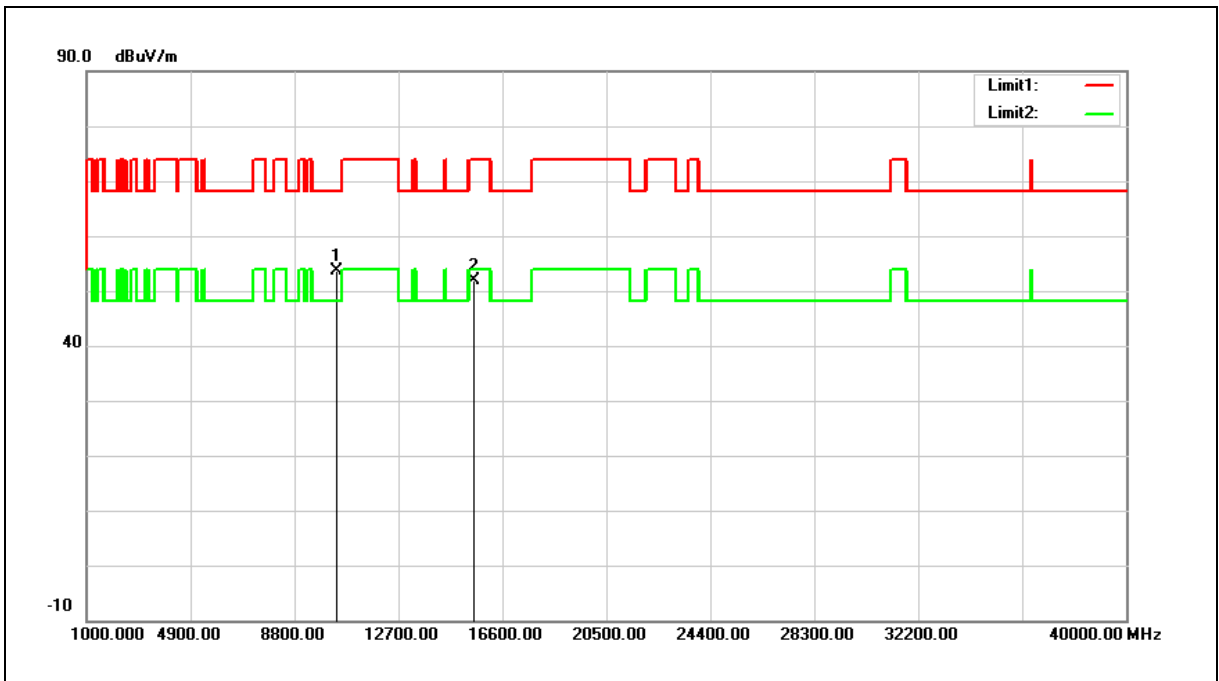

No.	Frequency (MHz)	Reading (dBuV)	Correct Factor (dB/m)	Result (dBuV/m)	Limit (dBuV/m)	Margin (dB)	Remark
1	10360.000	37.68	16.07	53.75	68.20	-14.45	peak
2	15540.000	33.92	18.03	51.95	74.00	-22.05	peak

Note:1.Result (dBuV/m) = Correct Factor (dB/m) + Reading(dBuV).

2.Correction factor (dB/m) = Antenna Factor (dB/m) + Cable loss (dB) – Pre-Amplifier gain (dB).

3.When the peak results are less than average limit, so not need to evaluate the average.

Standard:	FCC Part 15.407	Test Distance:	3 m
Test item:	Harmonic		
Frequency:	5180 MHz		
Mode:	Mode 1		
Ant.Polar.:	Vertical		

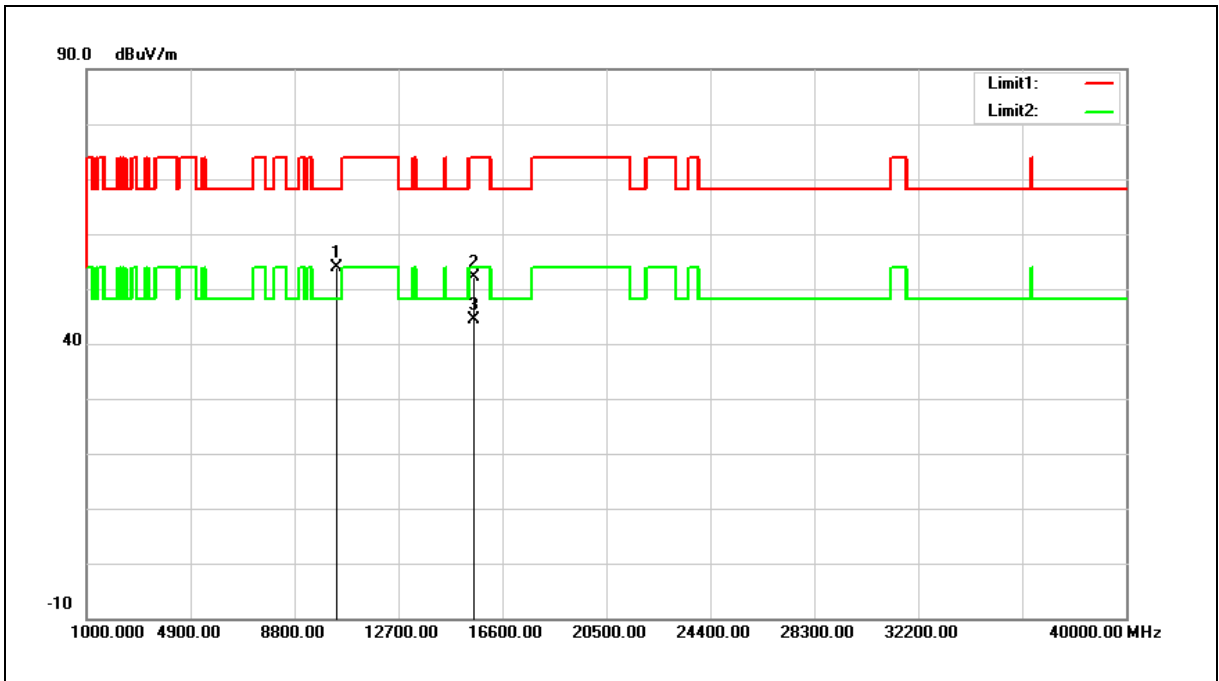

No.	Frequency (MHz)	Reading (dBuV)	Correct Factor (dB/m)	Result (dBuV/m)	Limit (dBuV/m)	Margin (dB)	Remark
1	10360.000	37.79	16.07	53.86	68.20	-14.34	peak
2	15540.000	34.14	18.03	52.17	74.00	-21.83	peak
3	15540.000	26.28	18.03	44.31	54.00	-9.69	AVG

Note:1.Result (dBuV/m) = Correct Factor (dB/m) + Reading(dBuV).

2.Correction factor (dB/m) = Antenna Factor (dB/m) + Cable loss (dB) – Pre-Amplifier gain (dB).

3.When the peak results are less than average limit, so not need to evaluate the average.

Standard:	FCC Part 15.407	Test Distance:	3 m
Test item:	Harmonic		
Frequency:	5200 MHz		
Mode:	Mode 1		
Ant.Polar.:	Horizontal		

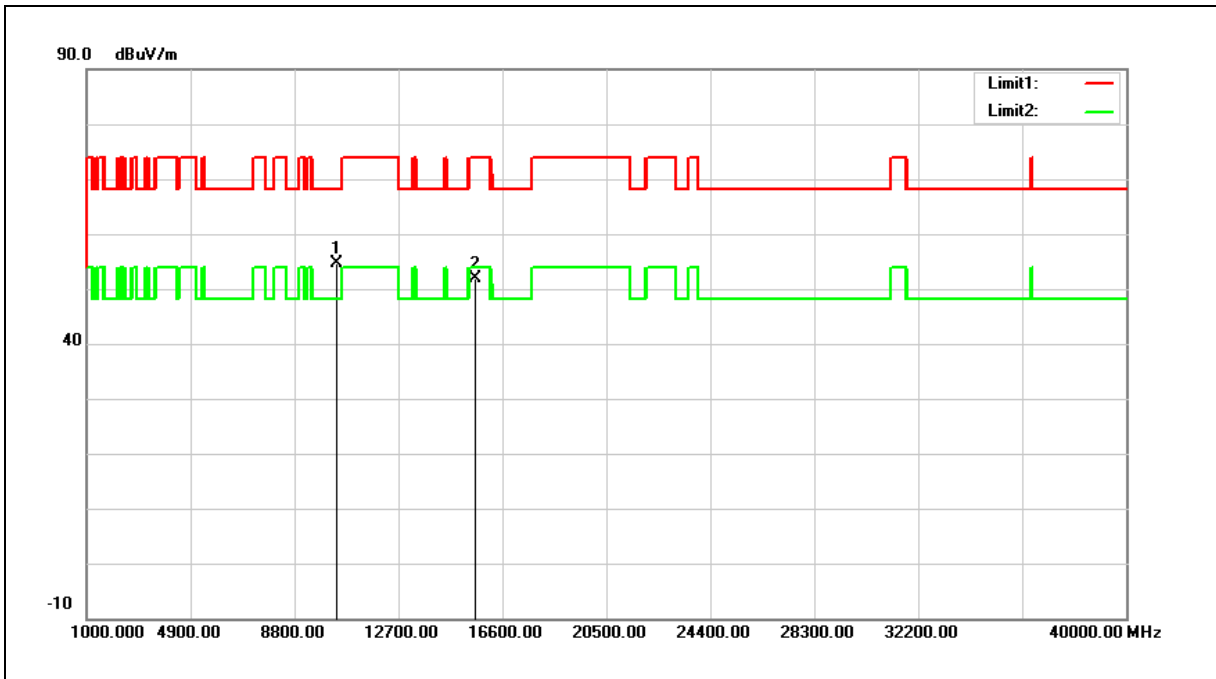

No.	Frequency (MHz)	Reading (dBuV)	Correct Factor (dB/m)	Result (dBuV/m)	Limit (dBuV/m)	Margin (dB)	Remark
1	10400.000	38.41	16.18	54.59	68.20	-13.61	peak
2	15600.000	34.16	17.76	51.92	74.00	-22.08	peak

Note:1.Result (dBuV/m) = Correct Factor (dB/m) + Reading(dBuV).

2.Correction factor (dB/m) = Antenna Factor (dB/m) + Cable loss (dB) – Pre-Amplifier gain (dB).

3.When the peak results are less than average limit, so not need to evaluate the average.

Standard:	FCC Part 15.407	Test Distance:	3 m
Test item:	Harmonic		
Frequency:	5200 MHz		
Mode:	Mode 1		
Ant.Polar.:	Vertical		

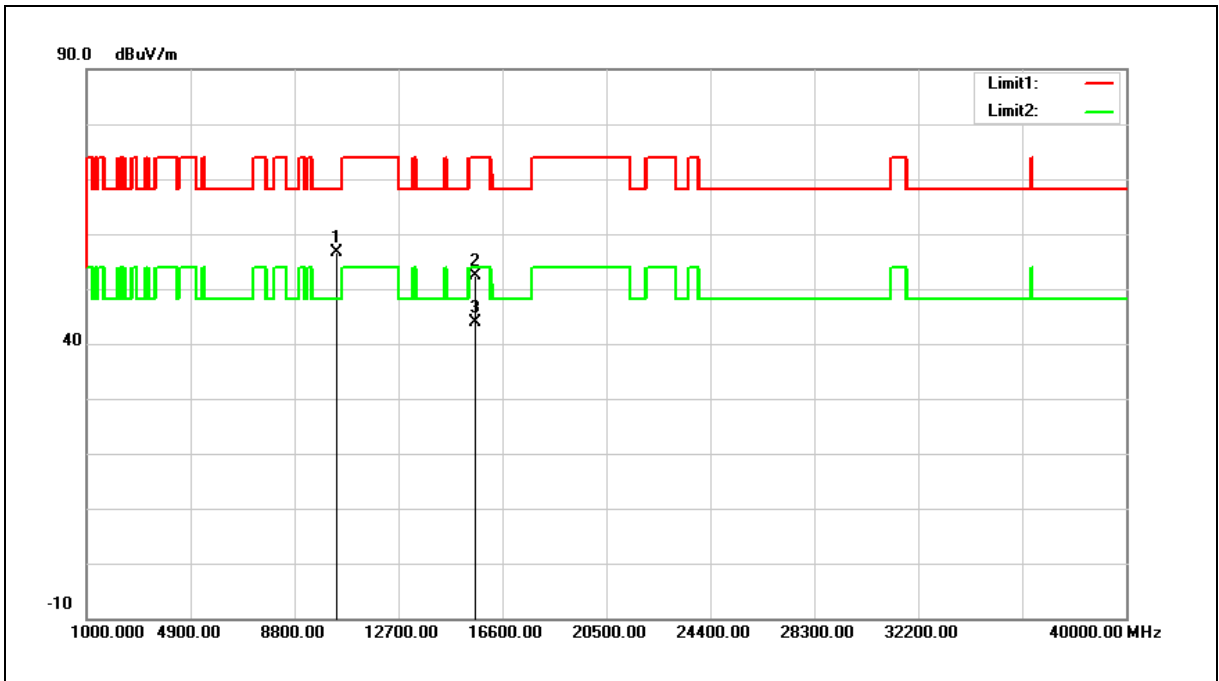

No.	Frequency (MHz)	Reading (dBuV)	Correct Factor (dB/m)	Result (dBuV/m)	Limit (dBuV/m)	Margin (dB)	Remark
1	10400.000	40.45	16.18	56.63	68.20	-11.57	peak
2	15600.000	34.52	17.76	52.28	74.00	-21.72	peak
3	15600.000	26.23	17.76	43.99	54.00	-10.01	AVG

Note:1.Result (dBuV/m) = Correct Factor (dB/m) + Reading(dBuV).

2.Correction factor (dB/m) = Antenna Factor (dB/m) + Cable loss (dB) – Pre-Amplifier gain (dB).

3.When the peak results are less than average limit, so not need to evaluate the average.

Standard:	FCC Part 15.407	Test Distance:	3 m
Test item:	Harmonic		
Frequency:	5240 MHz		
Mode:	Mode 1		
Ant.Polar.:	Horizontal		

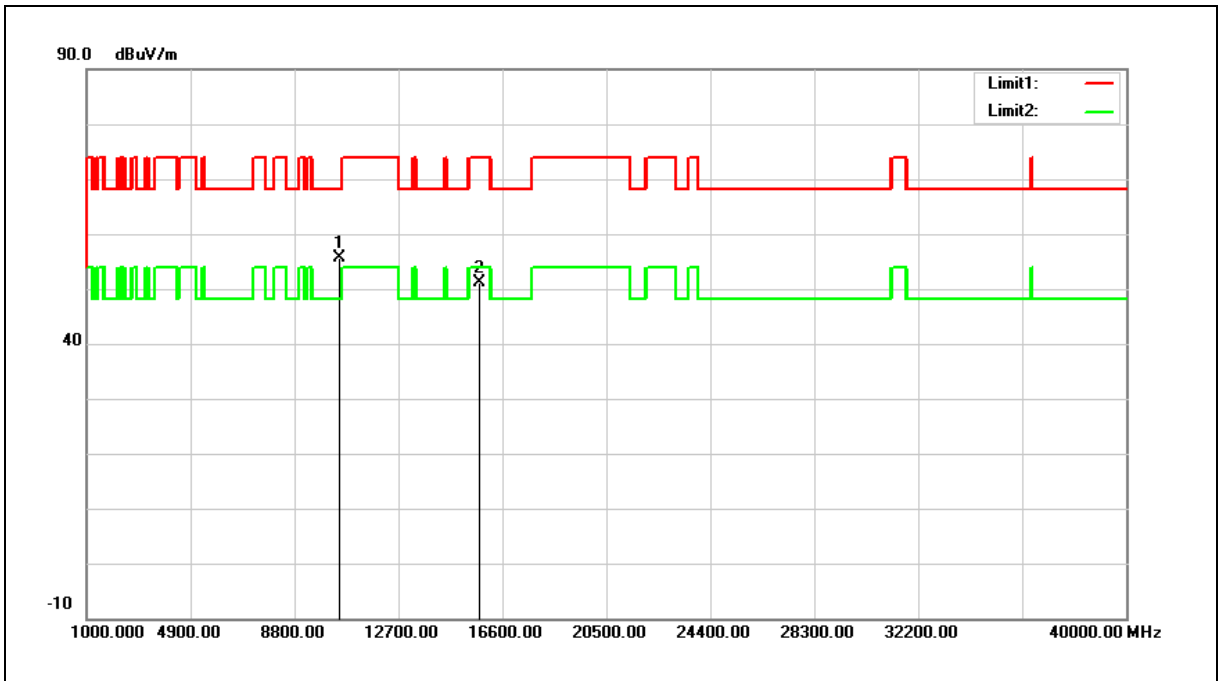

No.	Frequency (MHz)	Reading (dBuV)	Correct Factor (dB/m)	Result (dBuV/m)	Limit (dBuV/m)	Margin (dB)	Remark
1	10480.000	39.37	16.38	55.75	68.20	-12.45	peak
2	15720.000	34.01	17.22	51.23	74.00	-22.77	peak

Note:1.Result (dBuV/m) = Correct Factor (dB/m) + Reading(dBuV).

2.Correction factor (dB/m) = Antenna Factor (dB/m) + Cable loss (dB) – Pre-Amplifier gain (dB).

3.When the peak results are less than average limit, so not need to evaluate the average.

Standard:	FCC Part 15.407	Test Distance:	3 m
Test item:	Harmonic		
Frequency:	5240 MHz		
Mode:	Mode 1		
Ant.Polar.:	Vertical		

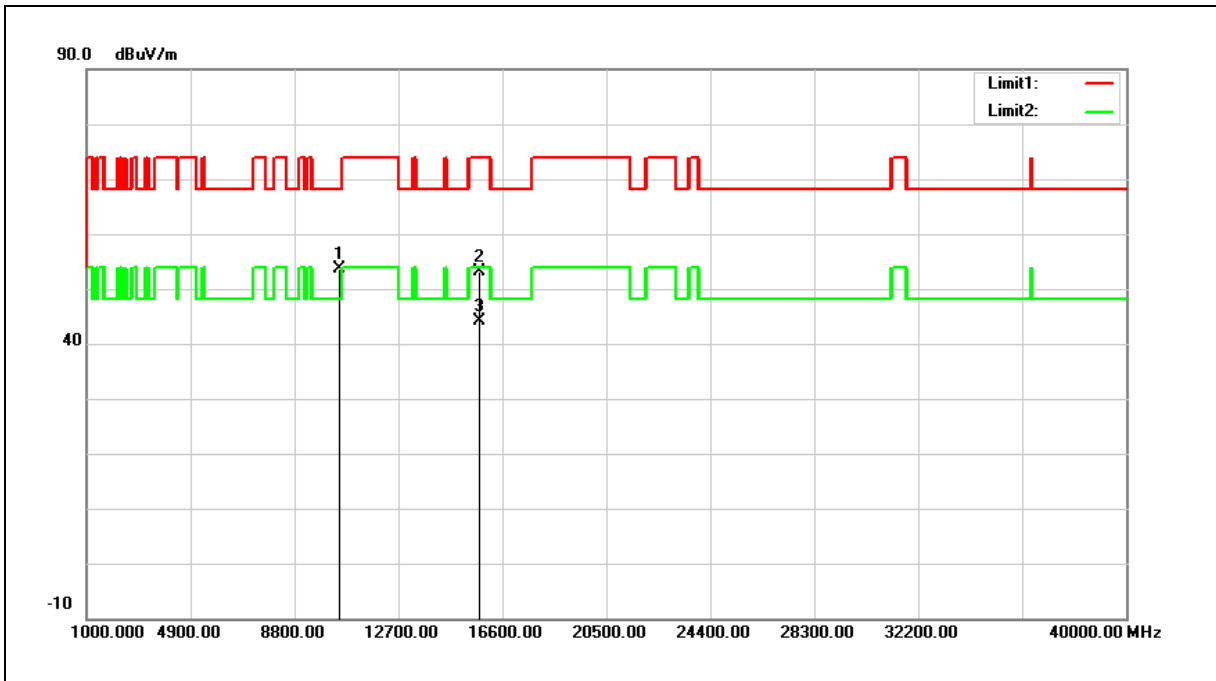

No.	Frequency (MHz)	Reading (dBuV)	Correct Factor (dB/m)	Result (dBuV/m)	Limit (dBuV/m)	Margin (dB)	Remark
1	10480.000	37.14	16.38	53.52	68.20	-14.68	peak
2	15720.000	35.91	17.22	53.13	74.00	-20.87	peak
3	15720.000	26.93	17.22	44.15	54.00	-9.85	AVG

Note:1.Result (dBuV/m) = Correct Factor (dB/m) + Reading(dBuV).

2.Correction factor (dB/m) = Antenna Factor (dB/m) + Cable loss (dB) – Pre-Amplifier gain (dB).

3.When the peak results are less than average limit, so not need to evaluate the average.

Standard:	FCC Part 15.407	Test Distance:	3 m
Test item:	Harmonic		
Frequency:	5745 MHz		
Mode:	Mode 1		
Ant.Polar.:	Horizontal		

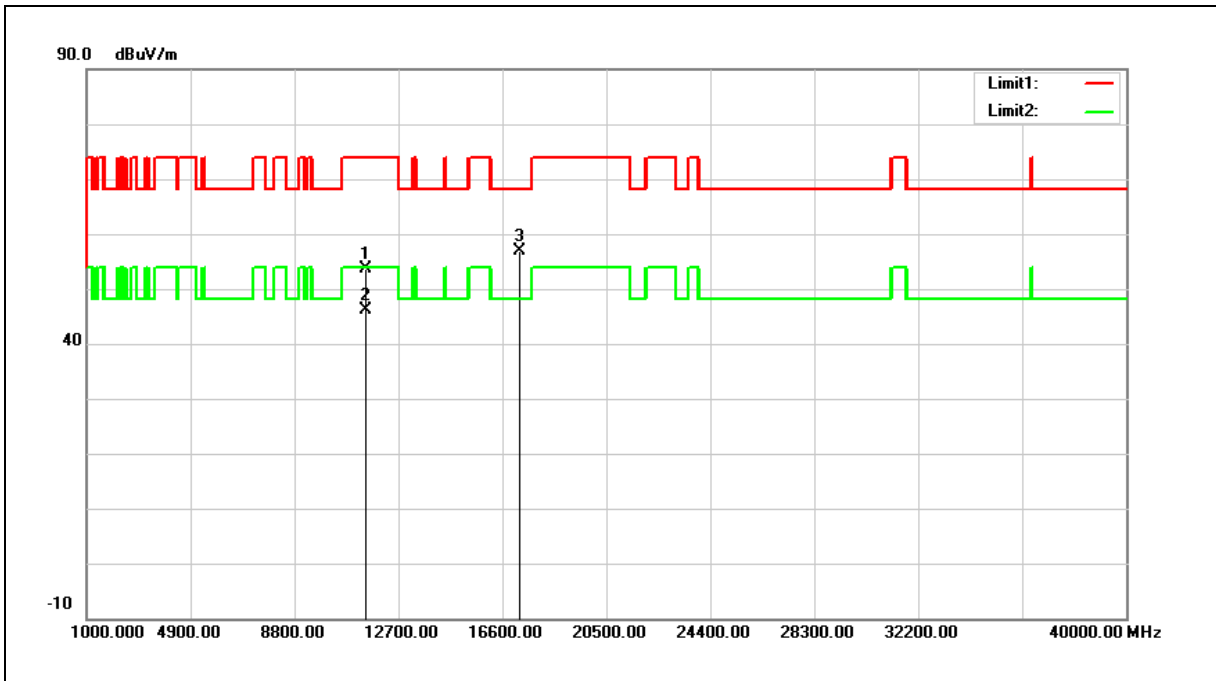

No.	Frequency (MHz)	Reading (dBuV)	Correct Factor (dB/m)	Result (dBuV/m)	Limit (dBuV/m)	Margin (dB)	Remark
1	11490.000	35.35	18.19	53.54	74.00	-20.46	peak
2	11490.000	28.01	18.19	46.20	54.00	-7.80	AVG
3	17235.000	33.50	23.43	56.93	68.20	-11.27	peak

Note:1.Result (dBuV/m) = Correct Factor (dB/m) + Reading(dBuV).

2.Correction factor (dB/m) = Antenna Factor (dB/m) + Cable loss (dB) – Pre-Amplifier gain (dB).

3.When the peak results are less than average limit, so not need to evaluate the average.

Standard:	FCC Part 15.407	Test Distance:	3 m
Test item:	Harmonic		
Frequency:	5745 MHz		
Mode:	Mode 1		
Ant.Polar.:	Vertical		

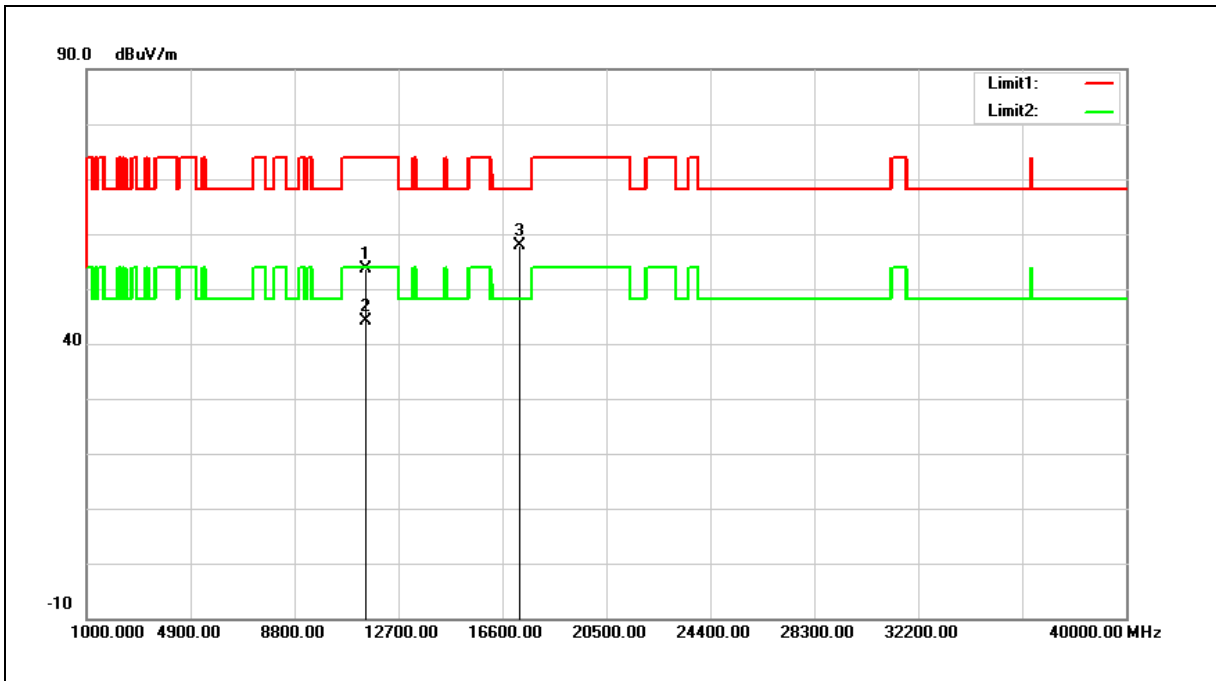

No.	Frequency (MHz)	Reading (dBuV)	Correct Factor (dB/m)	Result (dBuV/m)	Limit (dBuV/m)	Margin (dB)	Remark
1	11490.000	35.43	18.19	53.62	74.00	-20.38	peak
2	11490.000	25.89	18.19	44.08	54.00	-9.92	AVG
3	17235.000	34.40	23.43	57.83	68.20	-10.37	peak

Note:1.Result (dBuV/m) = Correct Factor (dB/m) + Reading(dBuV).

2.Correction factor (dB/m) = Antenna Factor (dB/m) + Cable loss (dB) – Pre-Amplifier gain (dB).

3.When the peak results are less than average limit, so not need to evaluate the average.

Standard:	FCC Part 15.407	Test Distance:	3 m
Test item:	Harmonic		
Frequency:	5785 MHz		
Mode:	Mode 1		
Ant.Polar.:	Horizontal		

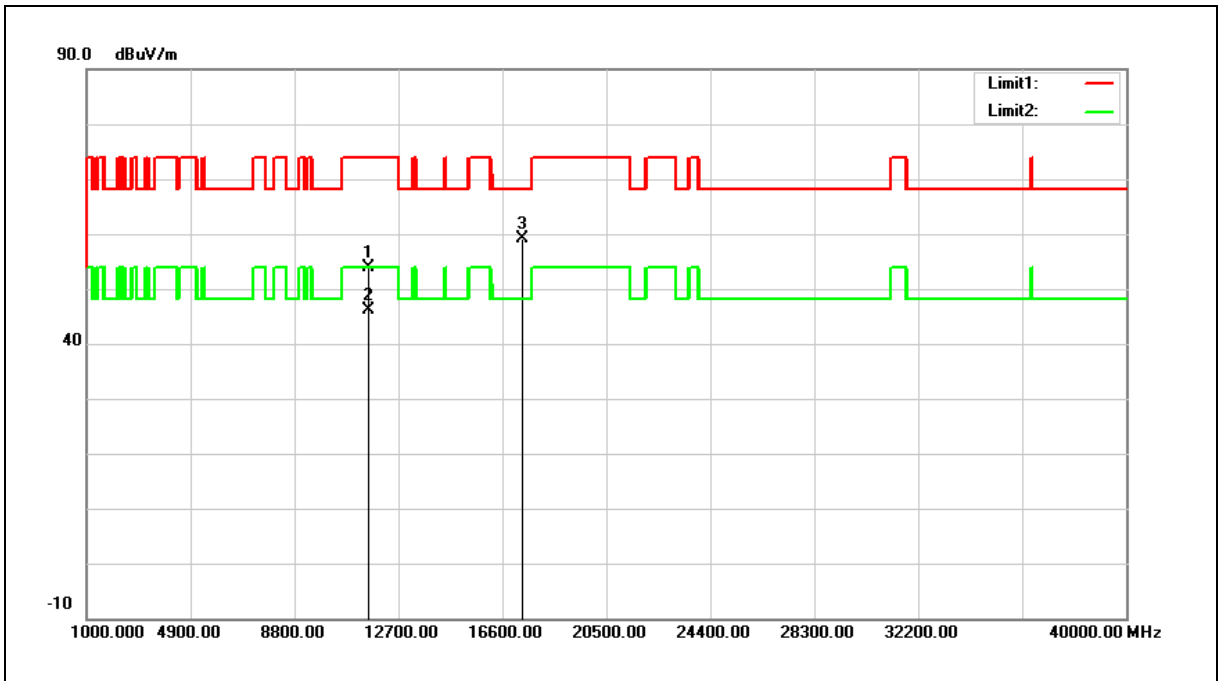

No.	Frequency (MHz)	Reading (dBuV)	Correct Factor (dB/m)	Result (dBuV/m)	Limit (dBuV/m)	Margin (dB)	Remark
1	11570.000	35.91	18.07	53.98	74.00	-20.02	peak
2	11570.000	28.07	18.07	46.14	54.00	-7.86	AVG
3	17355.000	35.10	24.04	59.14	68.20	-9.06	peak

Note:1.Result (dBuV/m) = Correct Factor (dB/m) + Reading(dBuV).

2.Correction factor (dB/m) = Antenna Factor (dB/m) + Cable loss (dB) – Pre-Amplifier gain (dB).

3.When the peak results are less than average limit, so not need to evaluate the average.

Standard:	FCC Part 15.407	Test Distance:	3 m
Test item:	Harmonic		
Frequency:	5785 MHz		
Mode:	Mode 1		
Ant.Polar.:	Vertical		

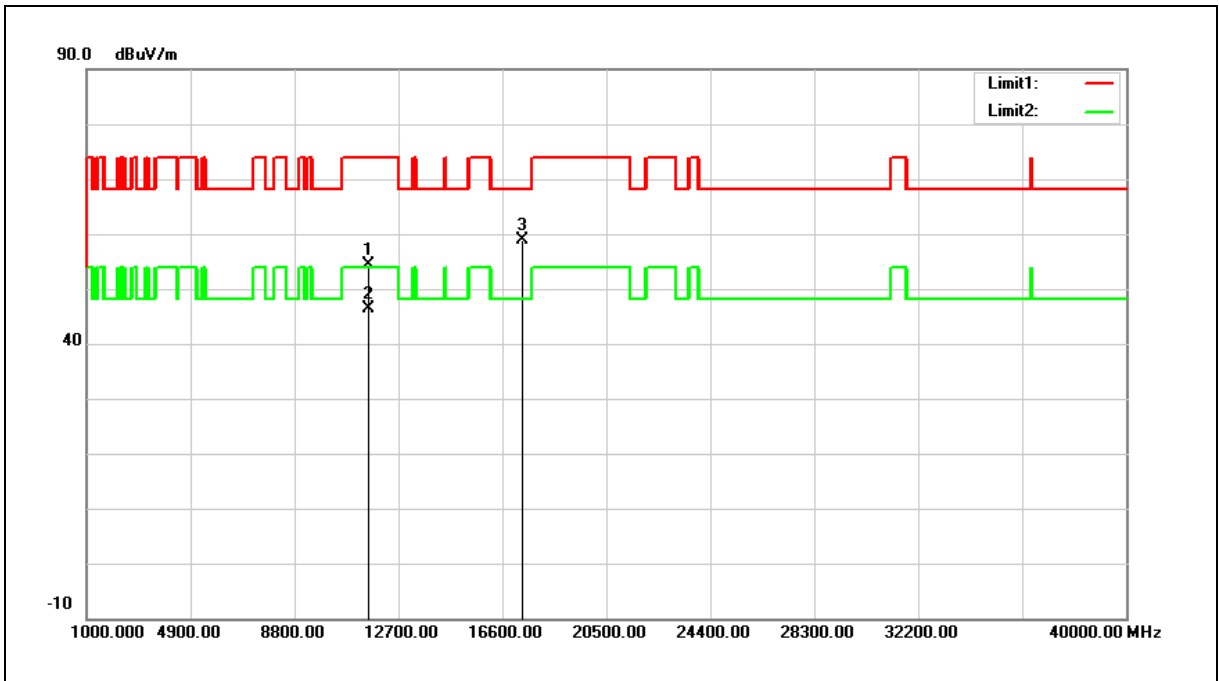

No.	Frequency (MHz)	Reading (dBuV)	Correct Factor (dB/m)	Result (dBuV/m)	Limit (dBuV/m)	Margin (dB)	Remark
1	11570.000	36.40	18.07	54.47	74.00	-19.53	peak
2	11570.000	28.28	18.07	46.35	54.00	-7.65	AVG
3	17355.000	34.87	24.04	58.91	68.20	-9.29	peak

Note:1.Result (dBuV/m) = Correct Factor (dB/m) + Reading(dBuV).

2.Correction factor (dB/m) = Antenna Factor (dB/m) + Cable loss (dB) – Pre-Amplifier gain (dB).

3.When the peak results are less than average limit, so not need to evaluate the average.

Standard:	FCC Part 15.407	Test Distance:	3 m
Test item:	Harmonic		
Frequency:	5825 MHz		
Mode:	Mode 1		
Ant.Polar.:	Horizontal		

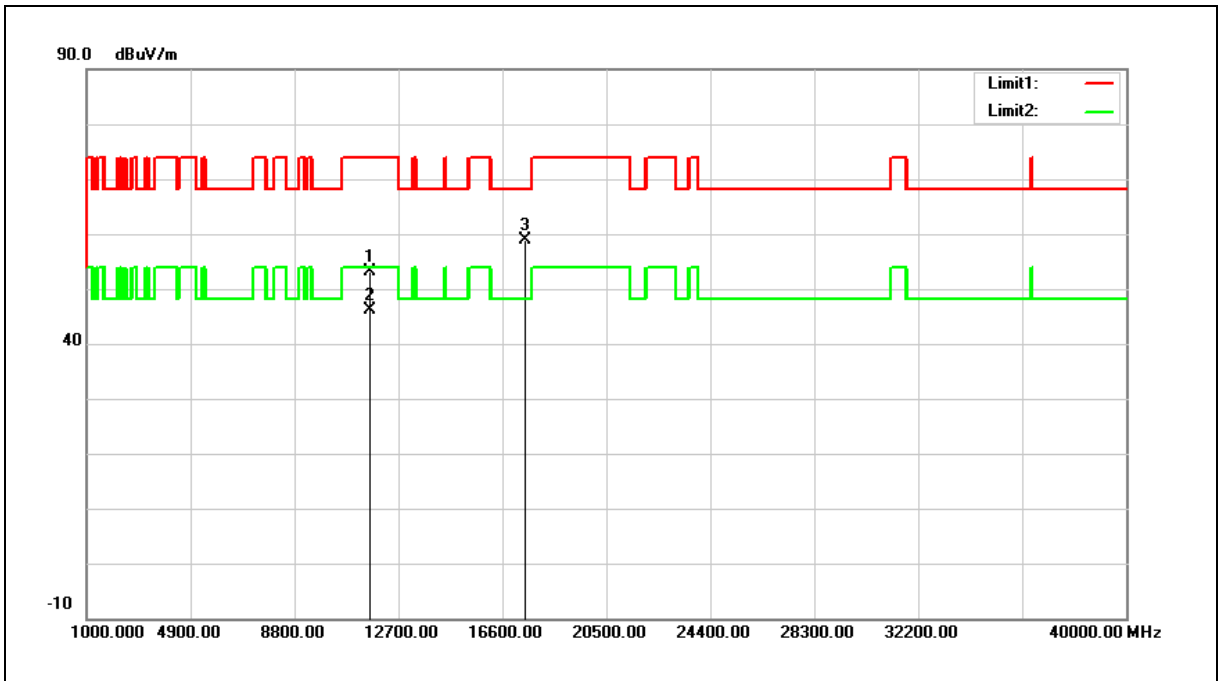

No.	Frequency (MHz)	Reading (dBuV)	Correct Factor (dB/m)	Result (dBuV/m)	Limit (dBuV/m)	Margin (dB)	Remark
1	11650.000	35.32	17.92	53.24	74.00	-20.76	peak
2	11650.000	28.17	17.92	46.09	54.00	-7.91	AVG
3	17475.000	34.12	24.64	58.76	68.20	-9.44	peak

Note:1.Result (dBuV/m) = Correct Factor (dB/m) + Reading(dBuV).

2.Correction factor (dB/m) = Antenna Factor (dB/m) + Cable loss (dB) – Pre-Amplifier gain (dB).

3.When the peak results are less than average limit, so not need to evaluate the average.

Standard:	FCC Part 15.407	Test Distance:	3 m
Test item:	Harmonic		
Frequency:	5825 MHz		
Mode:	Mode 1		
Ant.Polar.:	Vertical		

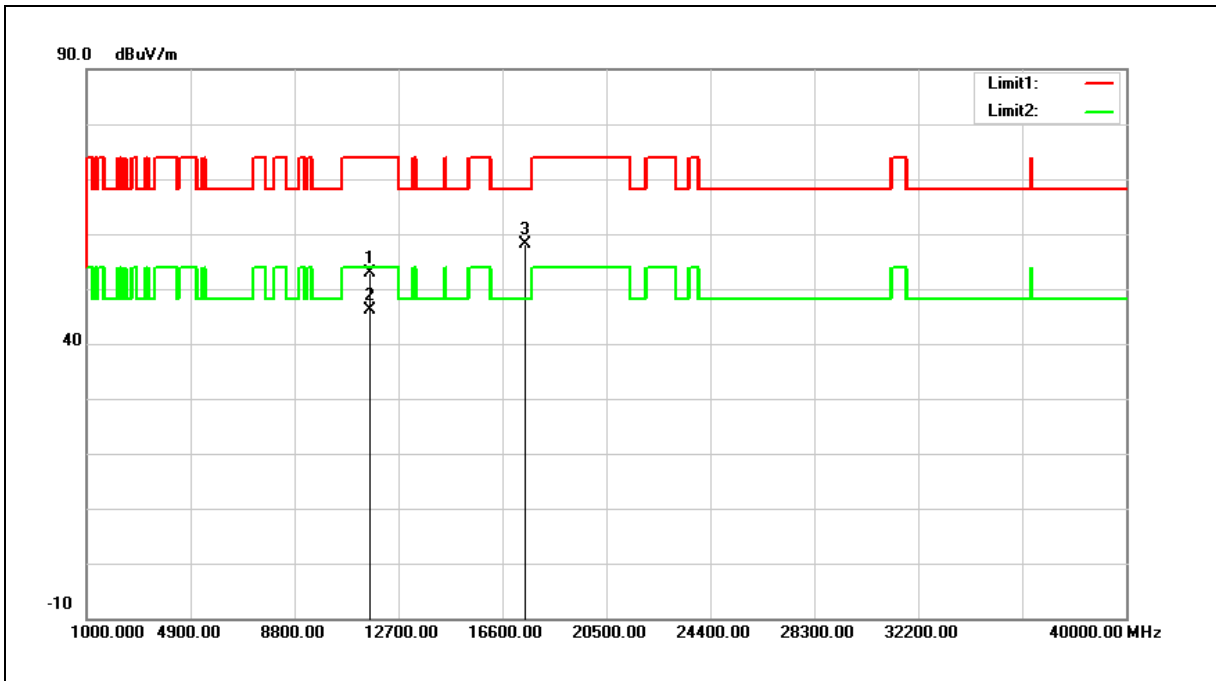

No.	Frequency (MHz)	Reading (dBuV)	Correct Factor (dB/m)	Result (dBuV/m)	Limit (dBuV/m)	Margin (dB)	Remark
1	11650.000	34.89	17.92	52.81	74.00	-21.19	peak
2	11650.000	28.31	17.92	46.23	54.00	-7.77	AVG
3	17475.000	33.57	24.64	58.21	68.20	-9.99	peak

Note:1.Result (dBuV/m) = Correct Factor (dB/m) + Reading(dBuV).

2.Correction factor (dB/m) = Antenna Factor (dB/m) + Cable loss (dB) – Pre-Amplifier gain (dB).

3.When the peak results are less than average limit, so not need to evaluate the average.

Standard:	FCC Part 15.407	Test Distance:	3 m
Test item:	Harmonic		
Frequency:	5180 MHz		
Mode:	Mode 2		
Ant.Polar.:	Horizontal		

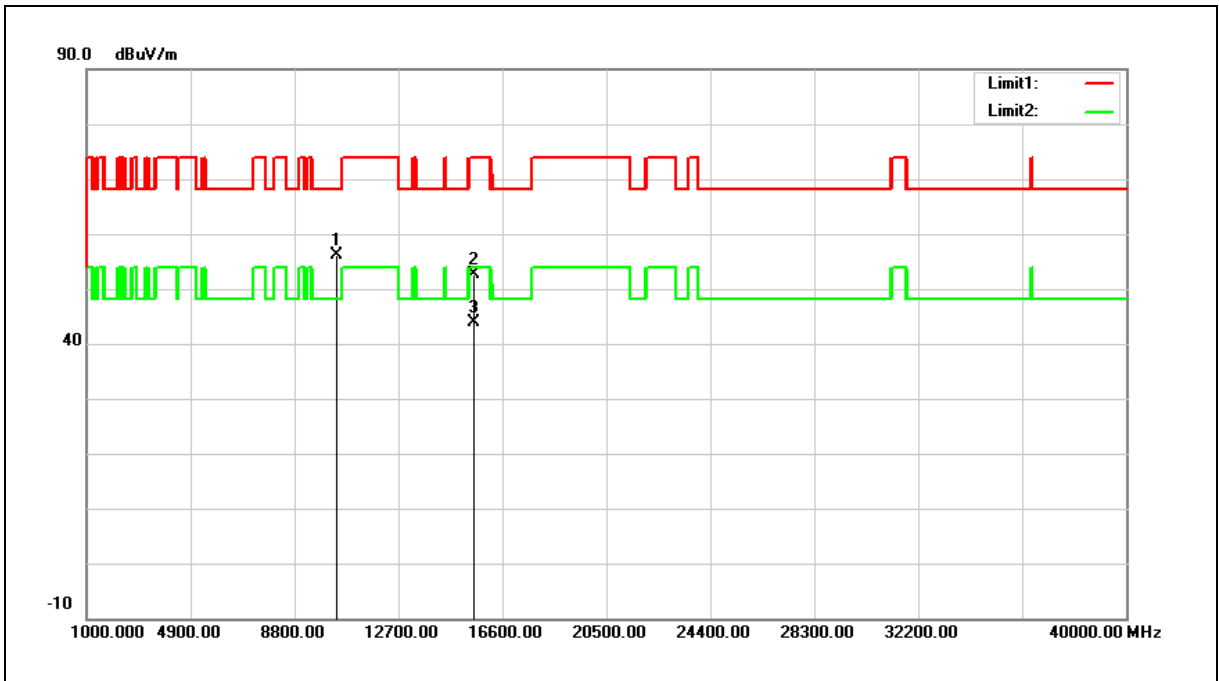

No.	Frequency (MHz)	Reading (dBuV)	Correct Factor (dB/m)	Result (dBuV/m)	Limit (dBuV/m)	Margin (dB)	Remark
1	10360.000	40.06	16.07	56.13	68.20	-12.07	peak
2	15540.000	34.60	18.03	52.63	74.00	-21.37	peak
3	15540.000	25.82	18.03	43.85	54.00	-10.15	AVG

Note:1.Result (dBuV/m) = Correct Factor (dB/m) + Reading(dBuV).

2.Correction factor (dB/m) = Antenna Factor (dB/m) + Cable loss (dB) – Pre-Amplifier gain (dB).

3.When the peak results are less than average limit, so not need to evaluate the average.

Standard:	FCC Part 15.407	Test Distance:	3 m
Test item:	Harmonic		
Frequency:	5180 MHz		
Mode:	Mode 2		
Ant.Polar.:	Vertical		

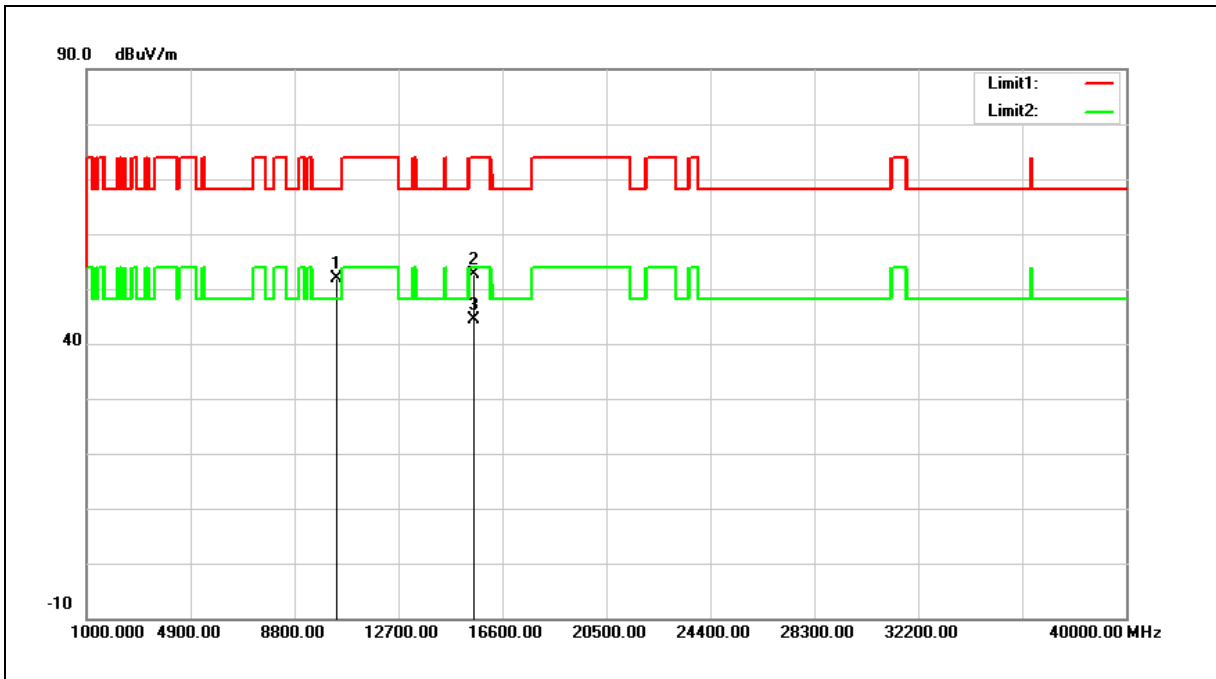

No.	Frequency (MHz)	Reading (dBuV)	Correct Factor (dB/m)	Result (dBuV/m)	Limit (dBuV/m)	Margin (dB)	Remark
1	10360.000	35.71	16.07	51.78	68.20	-16.42	peak
2	15540.000	34.65	18.03	52.68	74.00	-21.32	peak
3	15540.000	26.28	18.03	44.31	54.00	-9.69	AVG

Note:1.Result (dBuV/m) = Correct Factor (dB/m) + Reading(dBuV).

2.Correction factor (dB/m) = Antenna Factor (dB/m) + Cable loss (dB) – Pre-Amplifier gain (dB).

3.When the peak results are less than average limit, so not need to evaluate the average.

Standard:	FCC Part 15.407	Test Distance:	3 m
Test item:	Harmonic		
Frequency:	5200 MHz		
Mode:	Mode 2		
Ant.Polar.:	Horizontal		

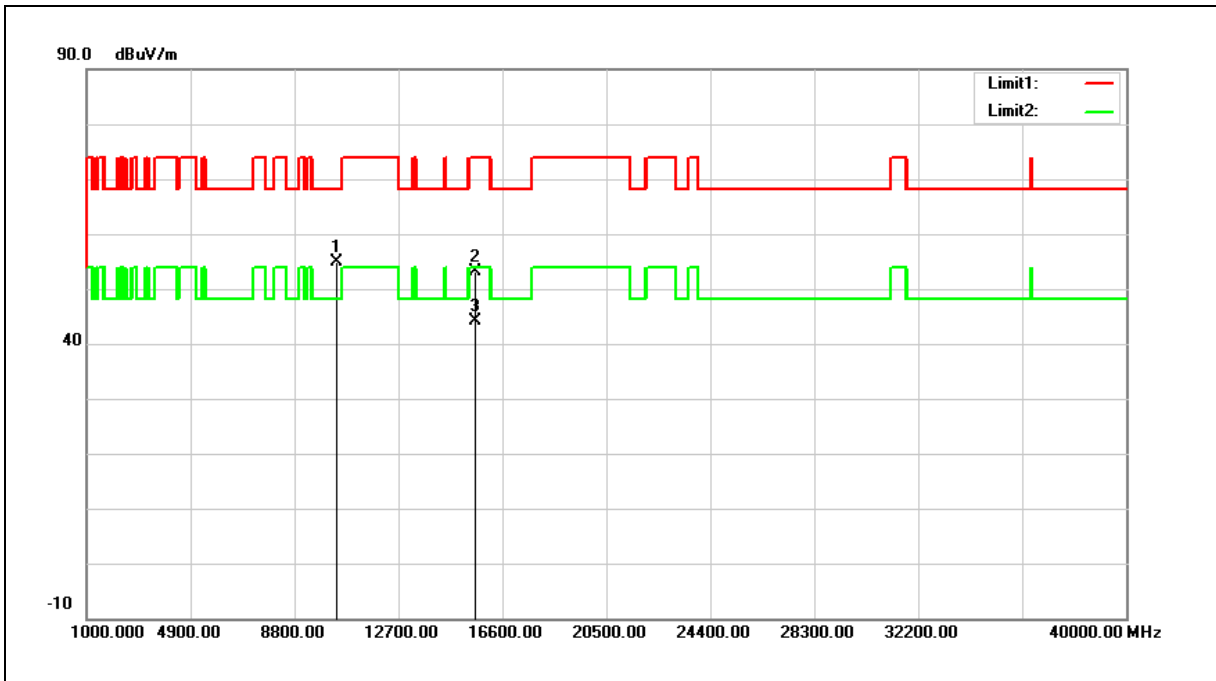

No.	Frequency (MHz)	Reading (dBuV)	Correct Factor (dB/m)	Result (dBuV/m)	Limit (dBuV/m)	Margin (dB)	Remark
1	10400.000	38.63	16.18	54.81	68.20	-13.39	peak
2	15600.000	35.29	17.76	53.05	74.00	-20.95	peak
3	15600.000	26.46	17.76	44.22	54.00	-9.78	AVG

Note:1.Result (dBuV/m) = Correct Factor (dB/m) + Reading(dBuV).

2.Correction factor (dB/m) = Antenna Factor (dB/m) + Cable loss (dB) – Pre-Amplifier gain (dB).

3.When the peak results are less than average limit, so not need to evaluate the average.

Standard:	FCC Part 15.407	Test Distance:	3 m
Test item:	Harmonic		
Frequency:	5200 MHz		
Mode:	Mode 2		
Ant.Polar.:	Vertical		

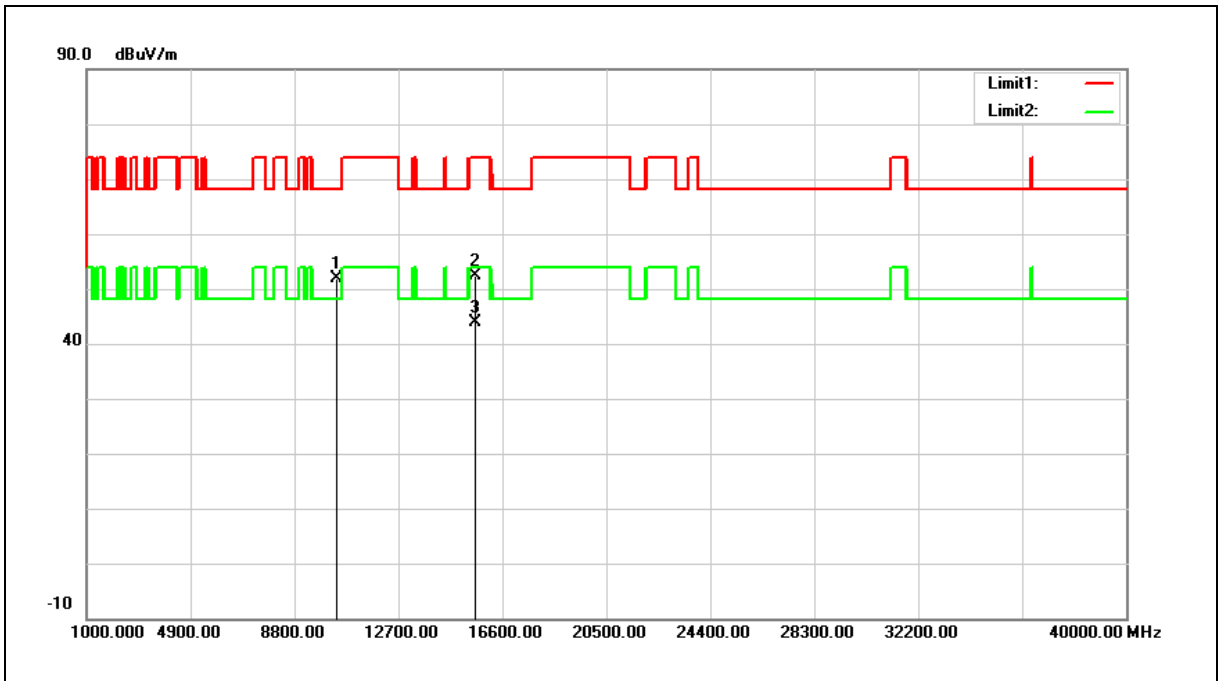

No.	Frequency (MHz)	Reading (dBuV)	Correct Factor (dB/m)	Result (dBuV/m)	Limit (dBuV/m)	Margin (dB)	Remark
1	10400.000	35.70	16.18	51.88	68.20	-16.32	peak
2	15600.000	34.55	17.76	52.31	74.00	-21.69	peak
3	15600.000	26.21	17.76	43.97	54.00	-10.03	AVG

Note:1.Result (dBuV/m) = Correct Factor (dB/m) + Reading(dBuV).

2.Correction factor (dB/m) = Antenna Factor (dB/m) + Cable loss (dB) – Pre-Amplifier gain (dB).

3.When the peak results are less than average limit, so not need to evaluate the average.

Standard:	FCC Part 15.407	Test Distance:	3 m
Test item:	Harmonic		
Frequency:	5240 MHz		
Mode:	Mode 2		
Ant.Polar.:	Horizontal		

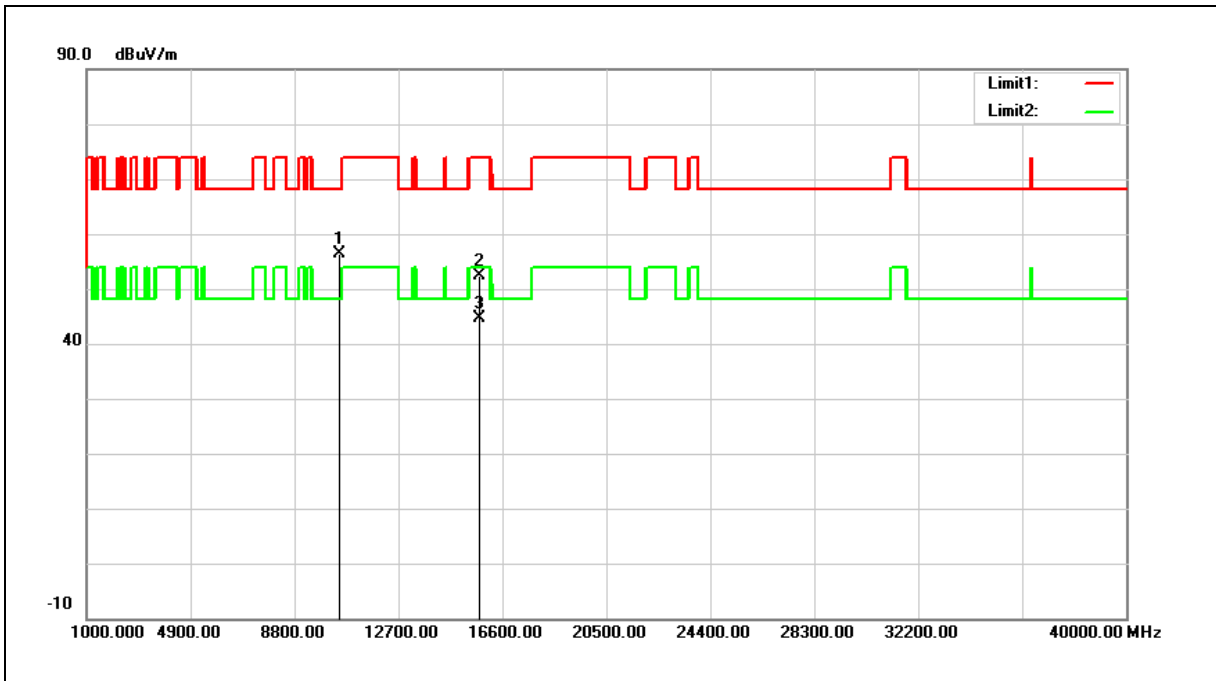

No.	Frequency (MHz)	Reading (dBuV)	Correct Factor (dB/m)	Result (dBuV/m)	Limit (dBuV/m)	Margin (dB)	Remark
1	10480.000	40.12	16.38	56.50	68.20	-11.70	peak
2	15720.000	35.08	17.22	52.30	74.00	-21.70	peak
3	15720.000	27.34	17.22	44.56	54.00	-9.44	AVG

Note:1.Result (dBuV/m) = Correct Factor (dB/m) + Reading(dBuV).

2.Correction factor (dB/m) = Antenna Factor (dB/m) + Cable loss (dB) – Pre-Amplifier gain (dB).

3.When the peak results are less than average limit, so not need to evaluate the average.

Standard:	FCC Part 15.407	Test Distance:	3 m
Test item:	Harmonic		
Frequency:	5240 MHz		
Mode:	Mode 2		
Ant.Polar.:	Vertical		

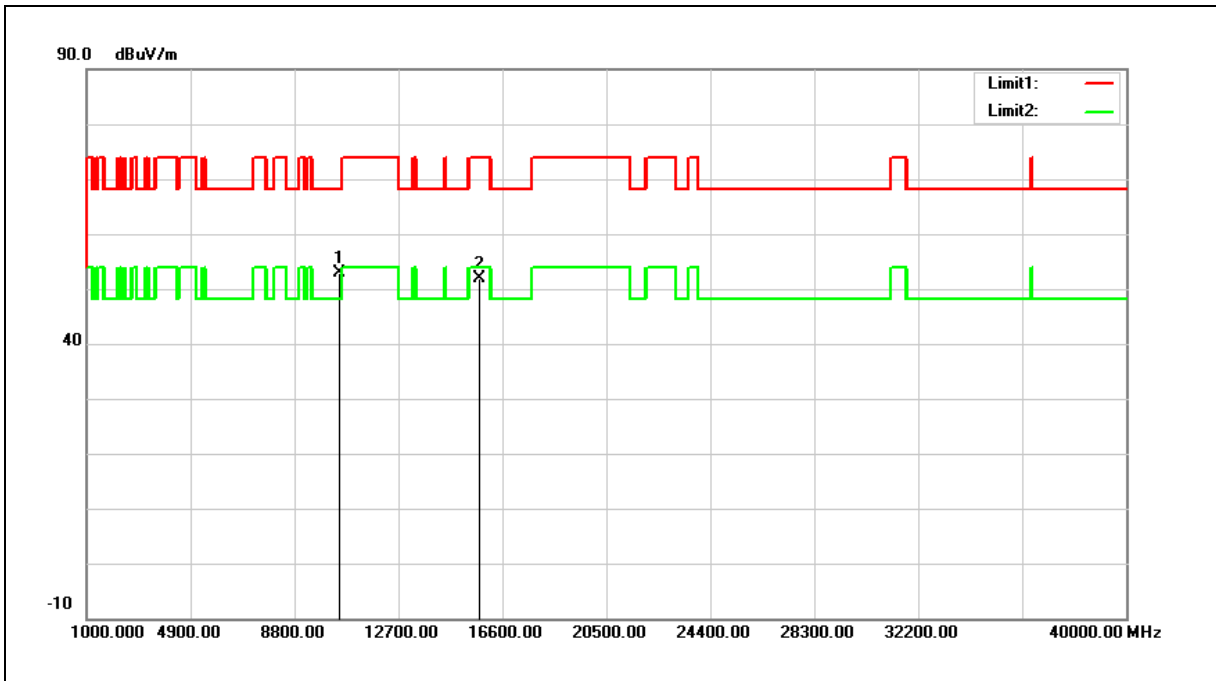

No.	Frequency (MHz)	Reading (dBuV)	Correct Factor (dB/m)	Result (dBuV/m)	Limit (dBuV/m)	Margin (dB)	Remark
1	10480.000	36.59	16.38	52.97	68.20	-15.23	peak
2	15720.000	34.65	17.22	51.87	74.00	-22.13	peak

Note:1.Result (dBuV/m) = Correct Factor (dB/m) + Reading(dBuV).

2.Correction factor (dB/m) = Antenna Factor (dB/m) + Cable loss (dB) – Pre-Amplifier gain (dB).

3.When the peak results are less than average limit, so not need to evaluate the average.

Standard:	FCC Part 15.407	Test Distance:	3 m
Test item:	Harmonic		
Frequency:	5745 MHz		
Mode:	Mode 2		
Ant.Polar.:	Horizontal		

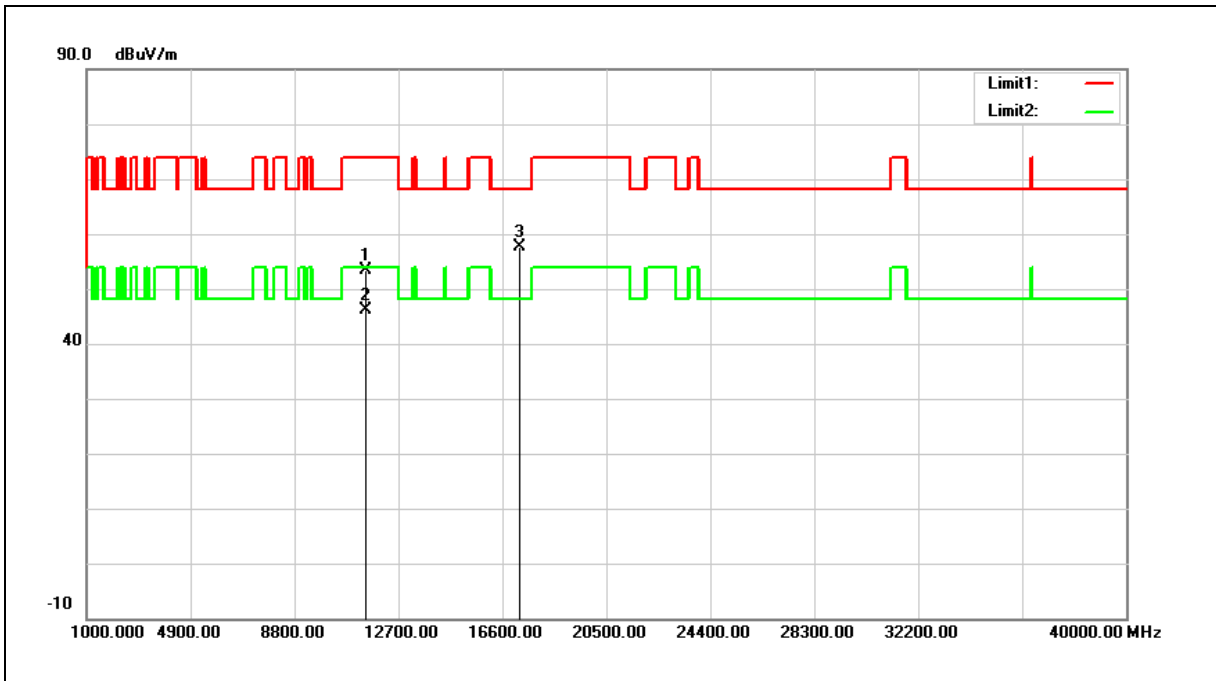

No.	Frequency (MHz)	Reading (dBuV)	Correct Factor (dB/m)	Result (dBuV/m)	Limit (dBuV/m)	Margin (dB)	Remark
1	11490.000	35.24	18.19	53.43	74.00	-20.57	peak
2	11490.000	27.98	18.19	46.17	54.00	-7.83	AVG
3	17235.000	34.28	23.43	57.71	68.20	-10.49	peak

Note:1.Result (dBuV/m) = Correct Factor (dB/m) + Reading(dBuV).

2.Correction factor (dB/m) = Antenna Factor (dB/m) + Cable loss (dB) – Pre-Amplifier gain (dB).

3.When the peak results are less than average limit, so not need to evaluate the average.

Standard:	FCC Part 15.407	Test Distance:	3 m
Test item:	Harmonic		
Frequency:	5745 MHz		
Mode:	Mode 2		
Ant.Polar.:	Vertical		

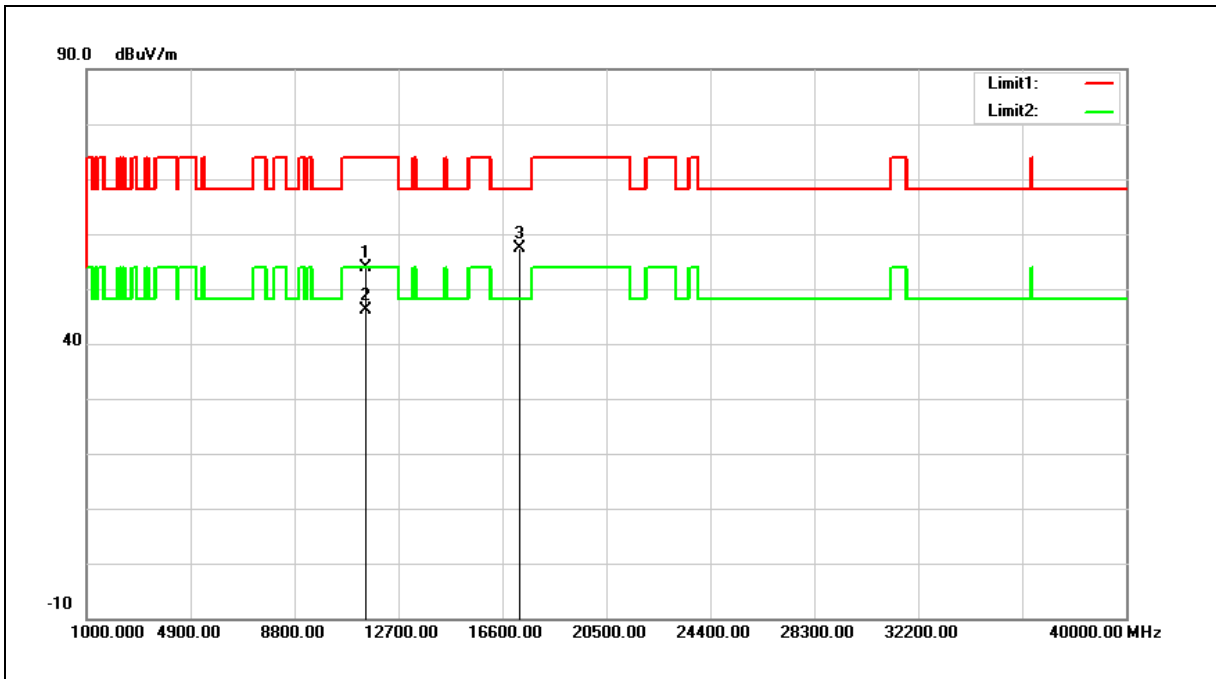

No.	Frequency (MHz)	Reading (dBuV)	Correct Factor (dB/m)	Result (dBuV/m)	Limit (dBuV/m)	Margin (dB)	Remark
1	11490.000	35.69	18.19	53.88	74.00	-20.12	peak
2	11490.000	28.06	18.19	46.25	54.00	-7.75	AVG
3	17235.000	34.03	23.43	57.46	68.20	-10.74	peak

Note:1.Result (dBuV/m) = Correct Factor (dB/m) + Reading(dBuV).

2.Correction factor (dB/m) = Antenna Factor (dB/m) + Cable loss (dB) – Pre-Amplifier gain (dB).

3.When the peak results are less than average limit, so not need to evaluate the average.

Standard:	FCC Part 15.407	Test Distance:	3 m
Test item:	Harmonic		
Frequency:	5785 MHz		
Mode:	Mode 2		
Ant.Polar.:	Horizontal		

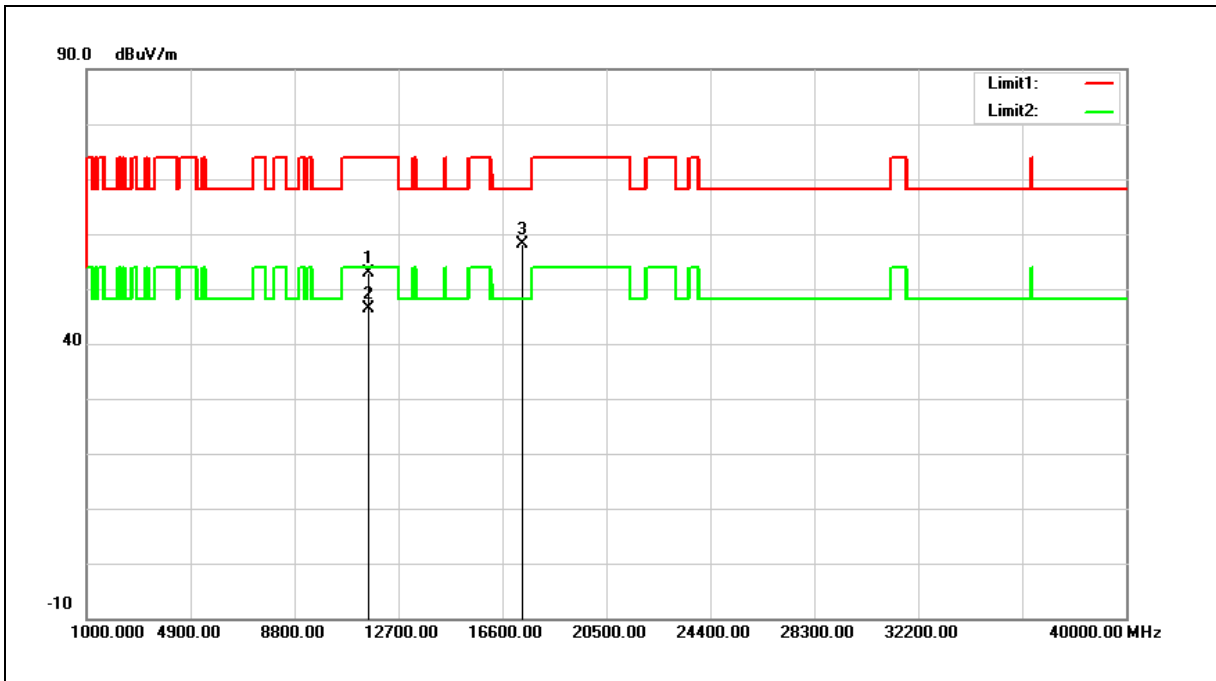

No.	Frequency (MHz)	Reading (dBuV)	Correct Factor (dB/m)	Result (dBuV/m)	Limit (dBuV/m)	Margin (dB)	Remark
1	11570.000	34.93	18.07	53.00	74.00	-21.00	peak
2	11570.000	28.32	18.07	46.39	54.00	-7.61	AVG
3	17355.000	34.06	24.04	58.10	68.20	-10.10	peak

Note:1.Result (dBuV/m) = Correct Factor (dB/m) + Reading(dBuV).

2.Correction factor (dB/m) = Antenna Factor (dB/m) + Cable loss (dB) – Pre-Amplifier gain (dB).

3.When the peak results are less than average limit, so not need to evaluate the average.

Standard:	FCC Part 15.407	Test Distance:	3 m
Test item:	Harmonic		
Frequency:	5785 MHz		
Mode:	Mode 2		
Ant.Polar.:	Vertical		

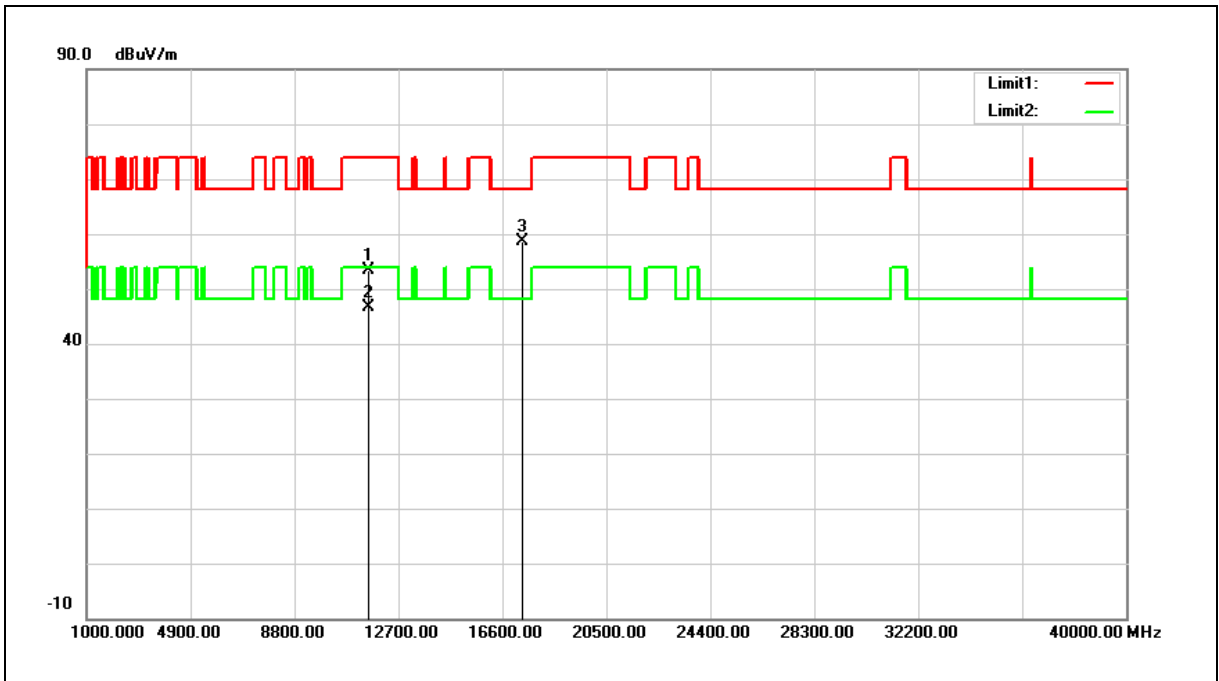

No.	Frequency (MHz)	Reading (dBuV)	Correct Factor (dB/m)	Result (dBuV/m)	Limit (dBuV/m)	Margin (dB)	Remark
1	11570.000	35.38	18.07	53.45	74.00	-20.55	peak
2	11570.000	28.64	18.07	46.71	54.00	-7.29	AVG
3	17355.000	34.70	24.04	58.74	68.20	-9.46	peak

Note:1.Result (dBuV/m) = Correct Factor (dB/m) + Reading(dBuV).

2.Correction factor (dB/m) = Antenna Factor (dB/m) + Cable loss (dB) – Pre-Amplifier gain (dB).

3.When the peak results are less than average limit, so not need to evaluate the average.

Standard:	FCC Part 15.407	Test Distance:	3 m
Test item:	Harmonic		
Frequency:	5825 MHz		
Mode:	Mode 2		
Ant.Polar.:	Horizontal		

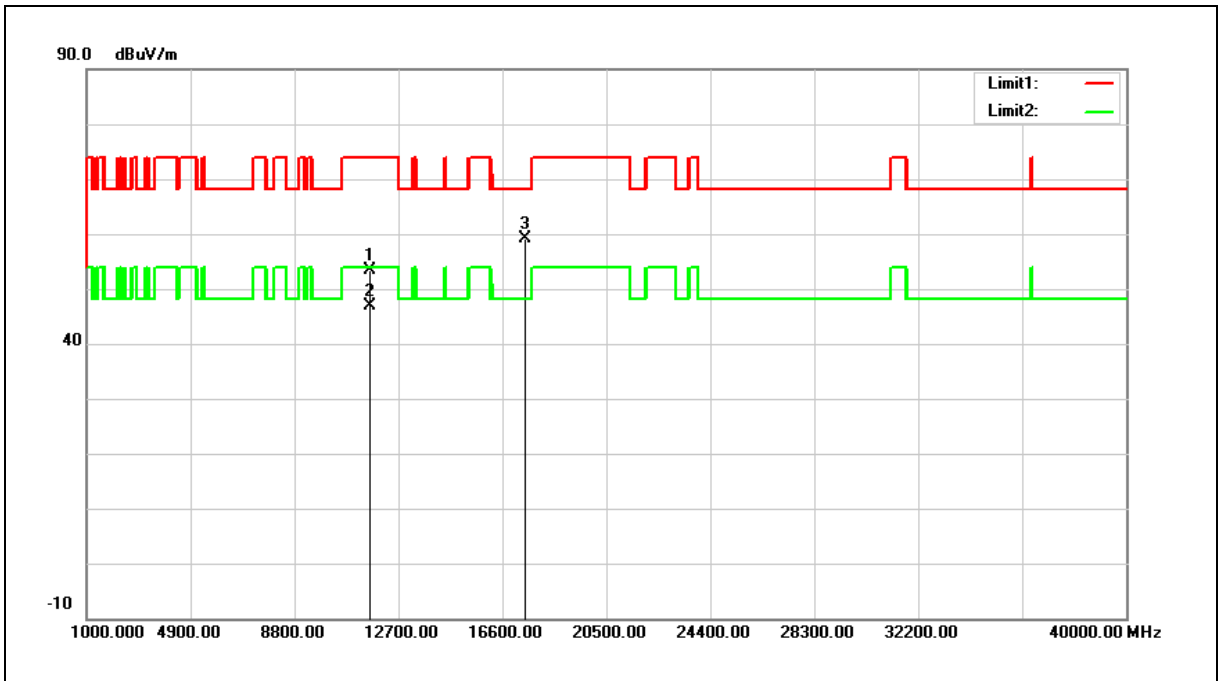

No.	Frequency (MHz)	Reading (dBuV)	Correct Factor (dB/m)	Result (dBuV/m)	Limit (dBuV/m)	Margin (dB)	Remark
1	11650.000	35.47	17.92	53.39	74.00	-20.61	peak
2	11650.000	28.97	17.92	46.89	54.00	-7.11	AVG
3	17475.000	34.37	24.64	59.01	68.20	-9.19	peak

Note:1.Result (dBuV/m) = Correct Factor (dB/m) + Reading(dBuV).

2.Correction factor (dB/m) = Antenna Factor (dB/m) + Cable loss (dB) – Pre-Amplifier gain (dB).

3.When the peak results are less than average limit, so not need to evaluate the average.

Standard:	FCC Part 15.407	Test Distance:	3 m
Test item:	Harmonic		
Frequency:	5825 MHz		
Mode:	Mode 2		
Ant.Polar.:	Vertical		

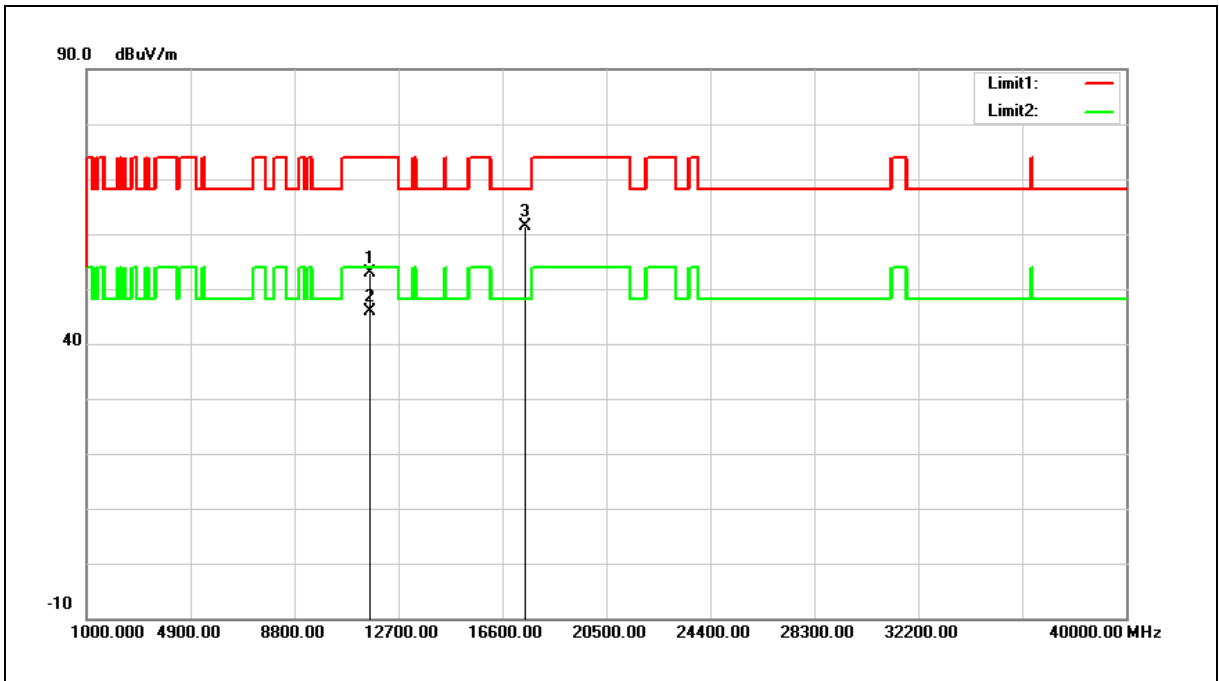

No.	Frequency (MHz)	Reading (dBuV)	Correct Factor (dB/m)	Result (dBuV/m)	Limit (dBuV/m)	Margin (dB)	Remark
1	11650.000	34.97	17.92	52.89	74.00	-21.11	peak
2	11650.000	28.02	17.92	45.94	54.00	-8.06	AVG
3	17475.000	36.72	24.64	61.36	68.20	-6.84	peak

Note:1.Result (dBuV/m) = Correct Factor (dB/m) + Reading(dBuV).

2.Correction factor (dB/m) = Antenna Factor (dB/m) + Cable loss (dB) – Pre-Amplifier gain (dB).

3.When the peak results are less than average limit, so not need to evaluate the average.

Band Edge

Peak

Standard:	FCC Part 15.407	Test Distance:	3 m
Test item:	Band edge		
Frequency:	5180 MHz		
Mode:	Mode 1		
Ant.Polar.:	Horizontal		

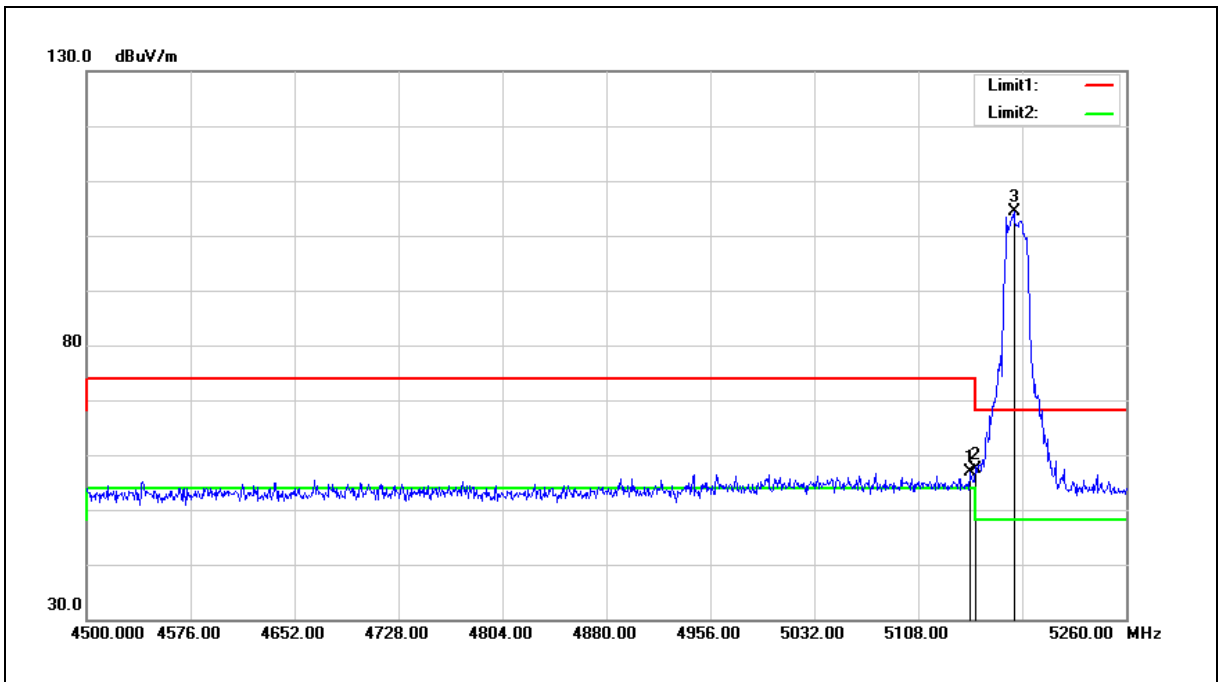

No.	Frequency (MHz)	Reading (dBuV)	Correct Factor (dB/m)	Result (dBuV/m)	Limit (dBuV/m)	Margin (dB)	Remark
1	5146.000	52.17	4.80	56.97	74.00	-17.03	peak
2	5150.000	52.49	4.80	57.29	74.00	-16.71	peak
3	5177.920	99.63	4.85	104.48	68.20	36.28	peak

Note:1.Result (dBuV/m) = Correct Factor (dB/m) + Reading(dBuV).

2.Correction factor (dB/m) = Antenna Factor (dB/m) + Cable loss (dB) – Pre-Amplifier gain (dB).

3.When the peak results are less than average limit, so not need to evaluate the average.

Standard:	FCC Part 15.407	Test Distance:	3 m
Test item:	Band edge		
Frequency:	5180 MHz		
Mode:	Mode 1		
Ant.Polar.:	Vertical		

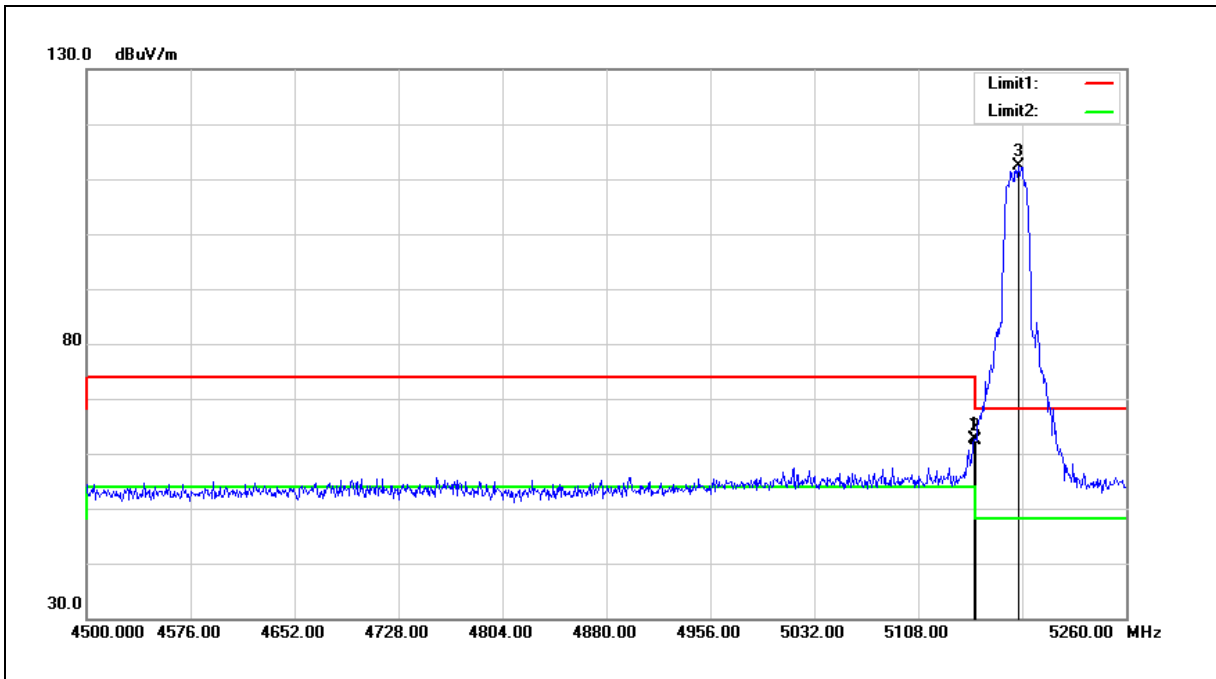

No.	Frequency (MHz)	Reading (dBuV)	Correct Factor (dB/m)	Result (dBuV/m)	Limit (dBuV/m)	Margin (dB)	Remark
1	5149.040	57.93	4.80	62.73	74.00	-11.27	peak
2	5150.000	57.54	4.80	62.34	74.00	-11.66	peak
3	5180.960	107.48	4.85	112.33	68.20	44.13	peak

Note:1.Result (dBuV/m) = Correct Factor (dB/m) + Reading(dBuV).

2.Correction factor (dB/m) = Antenna Factor (dB/m) + Cable loss (dB) – Pre-Amplifier gain (dB).

3.When the peak results are less than average limit, so not need to evaluate the average.

Standard:	FCC Part 15.407	Test Distance:	3 m
Test item:	Band edge		
Frequency:	5240 MHz		
Mode:	Mode 1		
Ant.Polar.:	Horizontal		

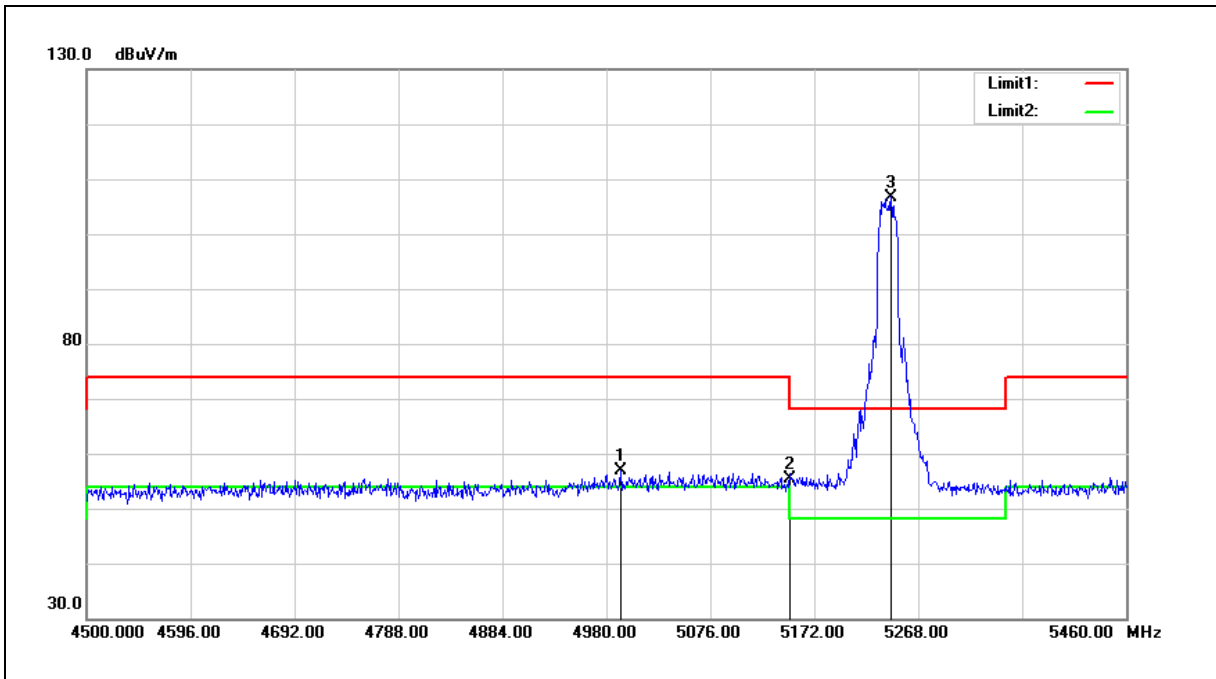

No.	Frequency (MHz)	Reading (dBuV)	Correct Factor (dB/m)	Result (dBuV/m)	Limit (dBuV/m)	Margin (dB)	Remark
1	4993.440	52.36	4.58	56.94	74.00	-17.06	peak
2	5150.000	50.50	4.80	55.30	74.00	-18.70	peak
3	5243.040	101.82	4.93	106.75	68.20	38.55	peak

Note:1.Result (dBuV/m) = Correct Factor (dB/m) + Reading(dBuV).

2.Correction factor (dB/m) = Antenna Factor (dB/m) + Cable loss (dB) – Pre-Amplifier gain (dB).

3.When the peak results are less than average limit, so not need to evaluate the average.

Standard:	FCC Part 15.407	Test Distance:	3 m
Test item:	Band edge		
Frequency:	5240 MHz		
Mode:	Mode 1		
Ant.Polar.:	Vertical		

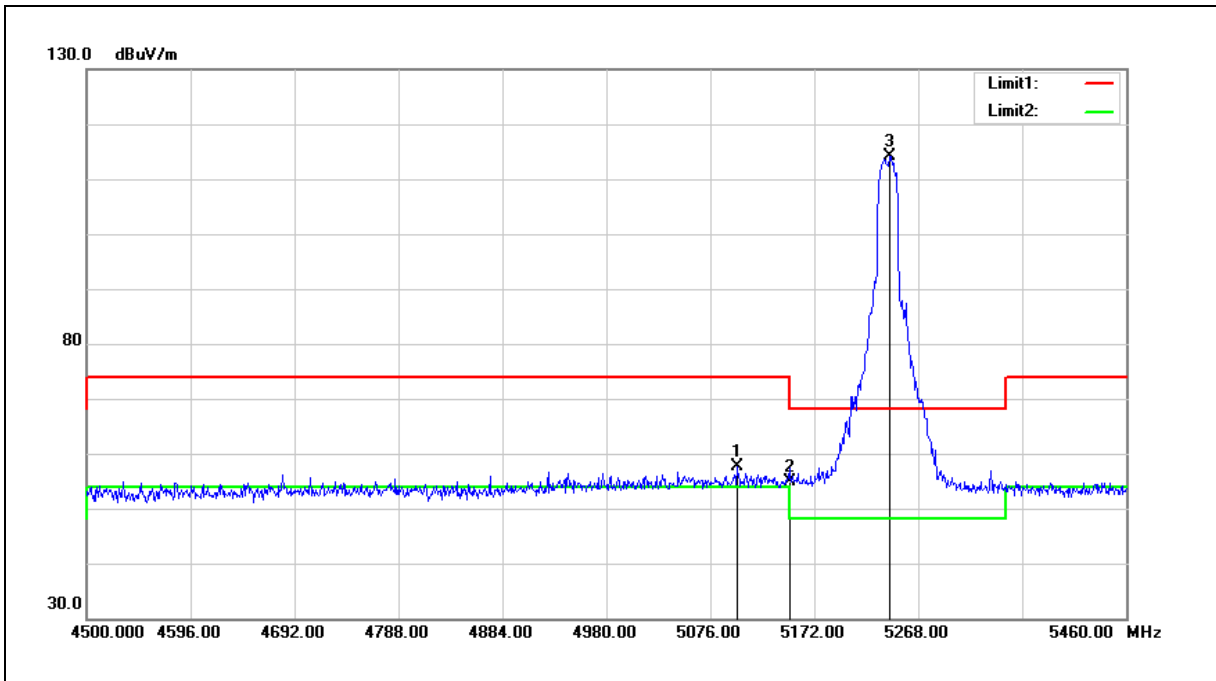

No.	Frequency (MHz)	Reading (dBuV)	Correct Factor (dB/m)	Result (dBuV/m)	Limit (dBuV/m)	Margin (dB)	Remark
1	5100.960	53.02	4.73	57.75	74.00	-16.25	peak
2	5150.000	50.07	4.80	54.87	74.00	-19.13	peak
3	5242.080	109.16	4.93	114.09	68.20	45.89	peak

Note:1.Result (dBuV/m) = Correct Factor (dB/m) + Reading(dBuV).

2.Correction factor (dB/m) = Antenna Factor (dB/m) + Cable loss (dB) – Pre-Amplifier gain (dB).

3.When the peak results are less than average limit, so not need to evaluate the average.

Standard:	FCC Part 15.407	Test Distance:	3 m
Test item:	Band edge		
Frequency:	5745 MHz		
Mode:	Mode 1		
Ant.Polar.:	Vertical		

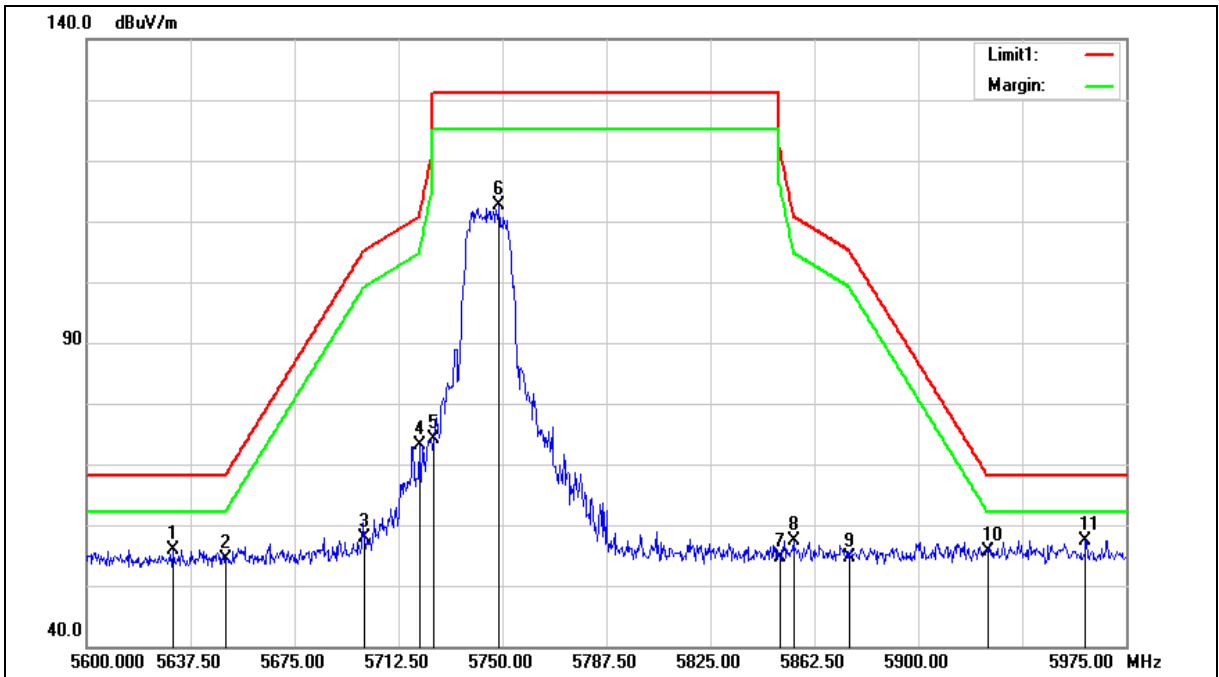

Standard:	FCC Part 15.407	Test Distance:	3 m
Test item:	Band edge		
Frequency:	5745 MHz		
Mode:	Mode 1		
Ant.Polar.:	Vertical		

No.	Frequency (MHz)	Reading (dBuV)	Correct Factor (dB/m)	Result (dBuV/m)	Limit (dBuV/m)	Margin (dB)	Remark
1	5631.125	50.44	5.55	55.99	68.20	-12.21	peak
2	5650.000	48.77	5.58	54.35	68.20	-13.85	peak
3	5700.000	52.18	5.68	57.86	105.20	-47.34	peak
4	5720.000	67.51	5.72	73.23	110.80	-37.57	peak
5	5725.000	68.52	5.73	74.25	122.20	-47.95	peak
6	5748.875	106.79	5.78	112.57	131.20	-18.63	peak
7	5850.000	48.69	5.99	54.68	122.20	-67.52	peak
8	5855.000	51.47	6.00	57.47	110.80	-53.33	peak
9	5875.000	48.54	6.04	54.58	105.20	-50.62	peak
10	5925.000	49.38	6.13	55.51	68.20	-12.69	peak
11	5960.375	51.22	6.20	57.42	68.20	-10.78	peak

Note:1.Result (dBuV/m) = Correct Factor (dB/m) + Reading(dBuV).

2.Correction factor (dB/m) = Antenna Factor (dB/m) + Cable loss (dB) – Pre-Amplifier gain (dB).

3.When the peak results are less than average limit, so not need to evaluate the average.

Standard:	FCC Part 15.407	Test Distance:	3 m
Test item:	Band edge		
Frequency:	5745 MHz		
Mode:	Mode 1		
Ant.Polar.:	Vertical		

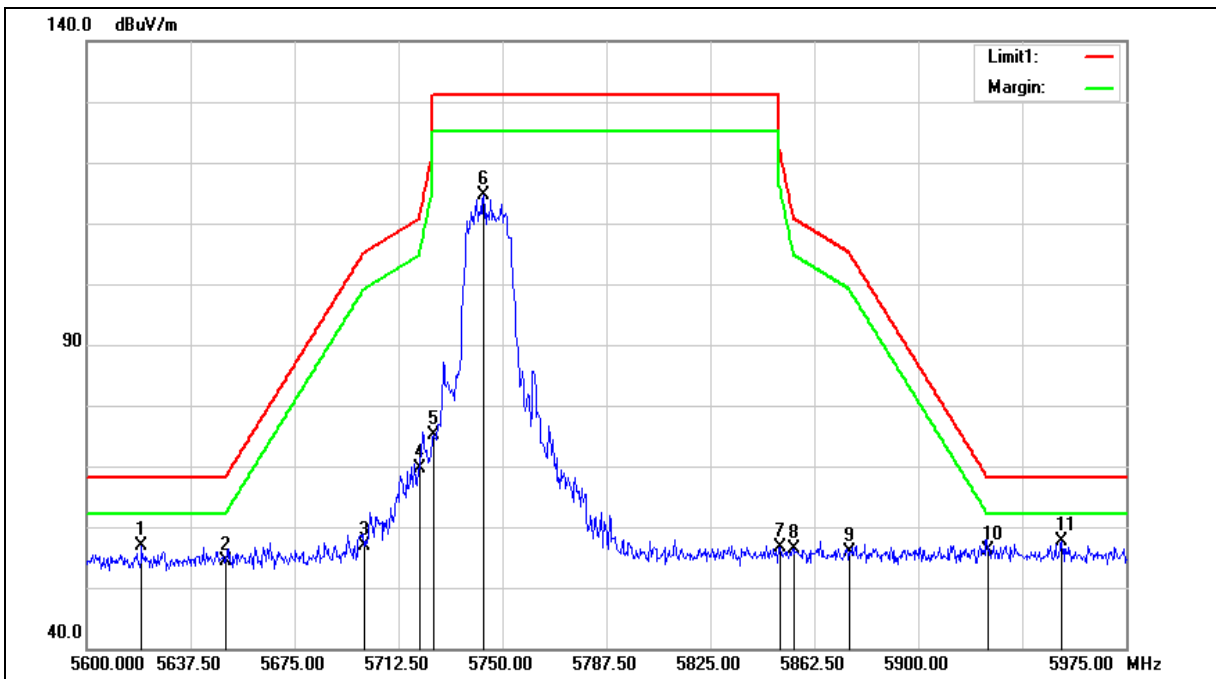

Standard:	FCC Part 15.407	Test Distance:	3 m
Test item:	Band edge		
Frequency:	5745 MHz		
Mode:	Mode 1		
Ant.Polar.:	Vertical		

No.	Frequency (MHz)	Reading (dBuV)	Correct Factor (dB/m)	Result (dBuV/m)	Limit (dBuV/m)	Margin (dB)	Remark
1	5619.875	51.28	5.52	56.80	68.20	-11.40	peak
2	5650.000	48.87	5.58	54.45	68.20	-13.75	peak
3	5700.000	51.11	5.68	56.79	105.20	-48.41	peak
4	5720.000	63.80	5.72	69.52	110.80	-41.28	peak
5	5725.000	69.40	5.73	75.13	122.20	-47.07	peak
6	5743.250	108.78	5.76	114.54	131.20	-16.66	peak
7	5850.000	50.69	5.99	56.68	122.20	-65.52	peak
8	5855.000	50.36	6.00	56.36	110.80	-54.44	peak
9	5875.000	49.84	6.04	55.88	105.20	-49.32	peak
10	5925.000	49.92	6.13	56.05	68.20	-12.15	peak
11	5951.750	51.50	6.18	57.68	68.20	-10.52	peak

Note:1.Result (dBuV/m) = Correct Factor (dB/m) + Reading(dBuV).

2.Correction factor (dB/m) = Antenna Factor (dB/m) + Cable loss (dB) – Pre-Amplifier gain (dB).

3.When the peak results are less than average limit, so not need to evaluate the average.

Standard:	FCC Part 15.407	Test Distance:	3 m
Test item:	Band edge		
Frequency:	5825 MHz		
Mode:	Mode 1		
Ant.Polar.:	Horizontal		

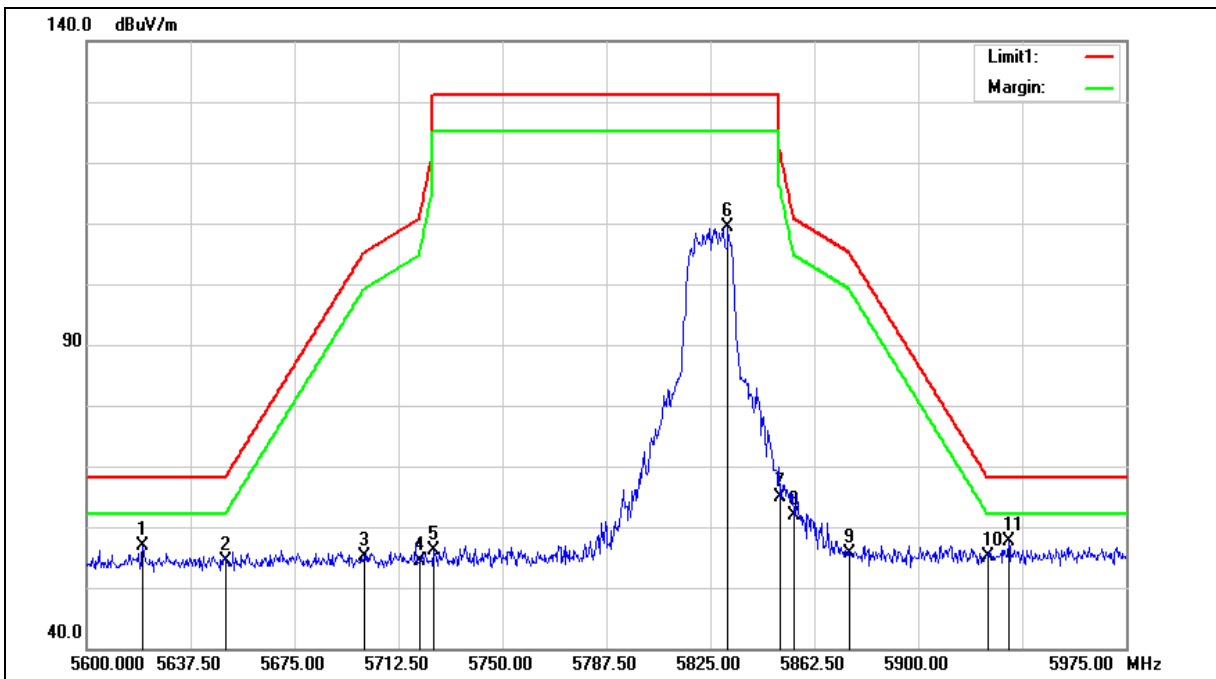

Standard:	FCC Part 15.407	Test Distance:	3 m
Test item:	Band edge		
Frequency:	5825 MHz		
Mode:	Mode 1		
Ant.Polar.:	Horizontal		

No.	Frequency (MHz)	Reading (dBuV)	Correct Factor (dB/m)	Result (dBuV/m)	Limit (dBuV/m)	Margin (dB)	Remark
1	5620.250	51.28	5.52	56.80	68.20	-11.40	peak
2	5650.000	48.86	5.58	54.44	68.20	-13.76	peak
3	5700.000	49.54	5.68	55.22	105.20	-49.98	peak
4	5720.000	48.57	5.72	54.29	110.80	-56.51	peak
5	5725.000	50.29	5.73	56.02	122.20	-66.18	peak
6	5831.375	103.33	5.94	109.27	131.20	-21.93	peak
7	5850.000	58.93	5.99	64.92	122.20	-57.28	peak
8	5855.000	55.76	6.00	61.76	110.80	-49.04	peak
9	5875.000	49.70	6.04	55.74	105.20	-49.46	peak
10	5925.000	49.02	6.13	55.15	68.20	-13.05	peak
11	5932.625	51.41	6.15	57.56	68.20	-10.64	peak

Note:1.Result (dBuV/m) = Correct Factor (dB/m) + Reading(dBuV).

2.Correction factor (dB/m) = Antenna Factor (dB/m) + Cable loss (dB) – Pre-Amplifier gain (dB).

3.When the peak results are less than average limit, so not need to evaluate the average.

Standard:	FCC Part 15.407	Test Distance:	3 m
Test item:	Band edge		
Frequency:	5825 MHz		
Mode:	Mode 1		
Ant.Polar.:	Vertical		

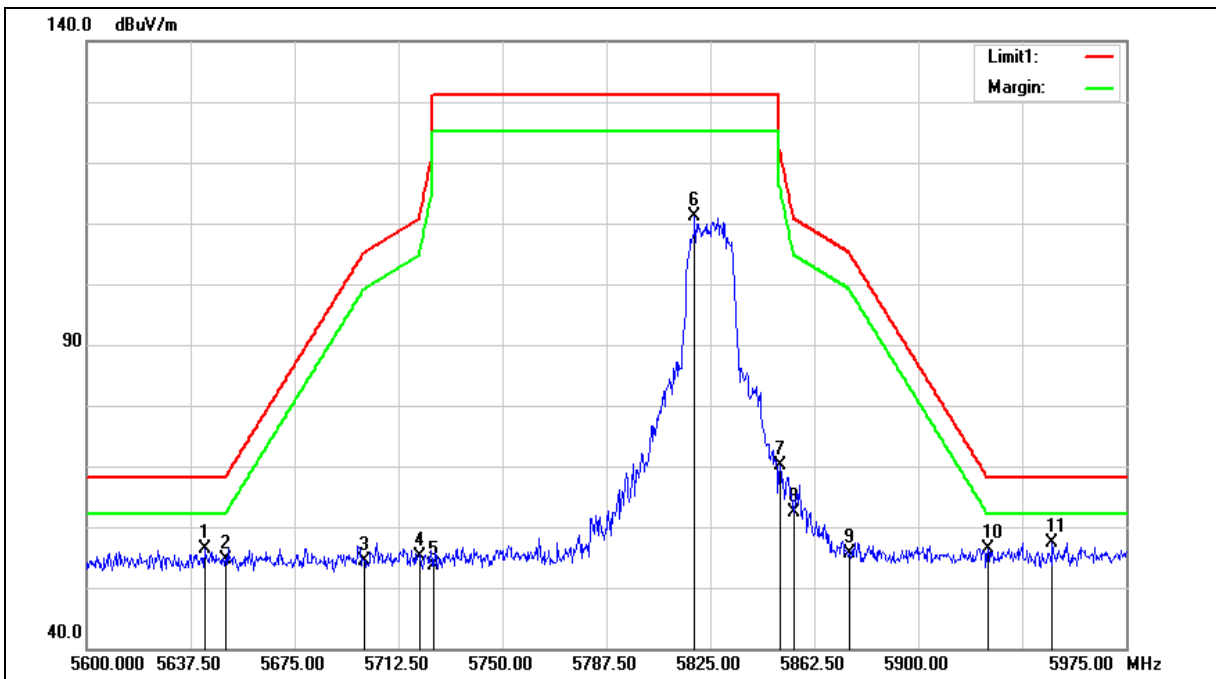

Standard:	FCC Part 15.407	Test Distance:	3 m
Test item:	Band edge		
Frequency:	5825 MHz		
Mode:	Mode 1		
Ant.Polar.:	Vertical		

No.	Frequency (MHz)	Reading (dBUV)	Correct Factor (dB/m)	Result (dBUV/m)	Limit (dBUV/m)	Margin (dB)	Remark
1	5642.750	50.92	5.57	56.49	68.20	-11.71	peak
2	5650.000	49.12	5.58	54.70	68.20	-13.50	peak
3	5700.000	48.66	5.68	54.34	105.20	-50.86	peak
4	5720.000	49.38	5.72	55.10	110.80	-55.70	peak
5	5725.000	47.78	5.73	53.51	122.20	-68.69	peak
6	5819.375	105.27	5.91	111.18	131.20	-20.02	peak
7	5850.000	64.22	5.99	70.21	122.20	-51.99	peak
8	5855.000	56.37	6.00	62.37	110.80	-48.43	peak
9	5875.000	49.50	6.04	55.54	105.20	-49.66	peak
10	5925.000	50.36	6.13	56.49	68.20	-11.71	peak
11	5948.375	51.28	6.18	57.46	68.20	-10.74	peak

Note:1.Result (dBUV/m) = Correct Factor (dB/m) + Reading(dBUV).

2.Correction factor (dB/m) = Antenna Factor (dB/m) + Cable loss (dB) – Pre-Amplifier gain (dB).

3.When the peak results are less than average limit, so not need to evaluate the average.

Standard:	FCC Part 15.407	Test Distance:	3 m
Test item:	Band edge		
Frequency:	5180 MHz		
Mode:	Mode 2		
Ant.Polar.:	Horizontal		

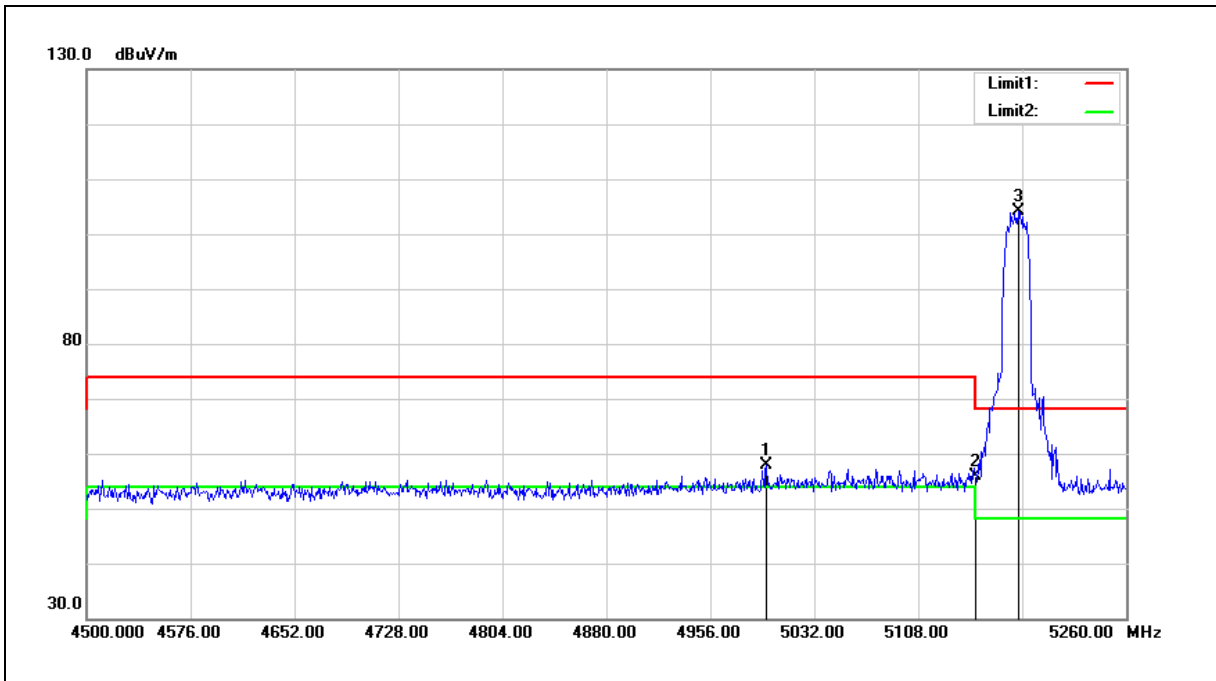

No.	Frequency (MHz)	Reading (dBuV)	Correct Factor (dB/m)	Result (dBuV/m)	Limit (dBuV/m)	Margin (dB)	Remark
1	4997.040	53.38	4.59	57.97	74.00	-16.03	peak
2	5150.000	51.13	4.80	55.93	74.00	-18.07	peak
3	5180.960	99.27	4.85	104.12	68.20	35.92	peak

Note:1.Result (dBuV/m) = Correct Factor (dB/m) + Reading(dBuV).

2.Correction factor (dB/m) = Antenna Factor (dB/m) + Cable loss (dB) – Pre-Amplifier gain (dB).

3.When the peak results are less than average limit, so not need to evaluate the average.

Standard:	FCC Part 15.407	Test Distance:	3 m
Test item:	Band edge		
Frequency:	5180 MHz		
Mode:	Mode 2		
Ant.Polar.:	Vertical		

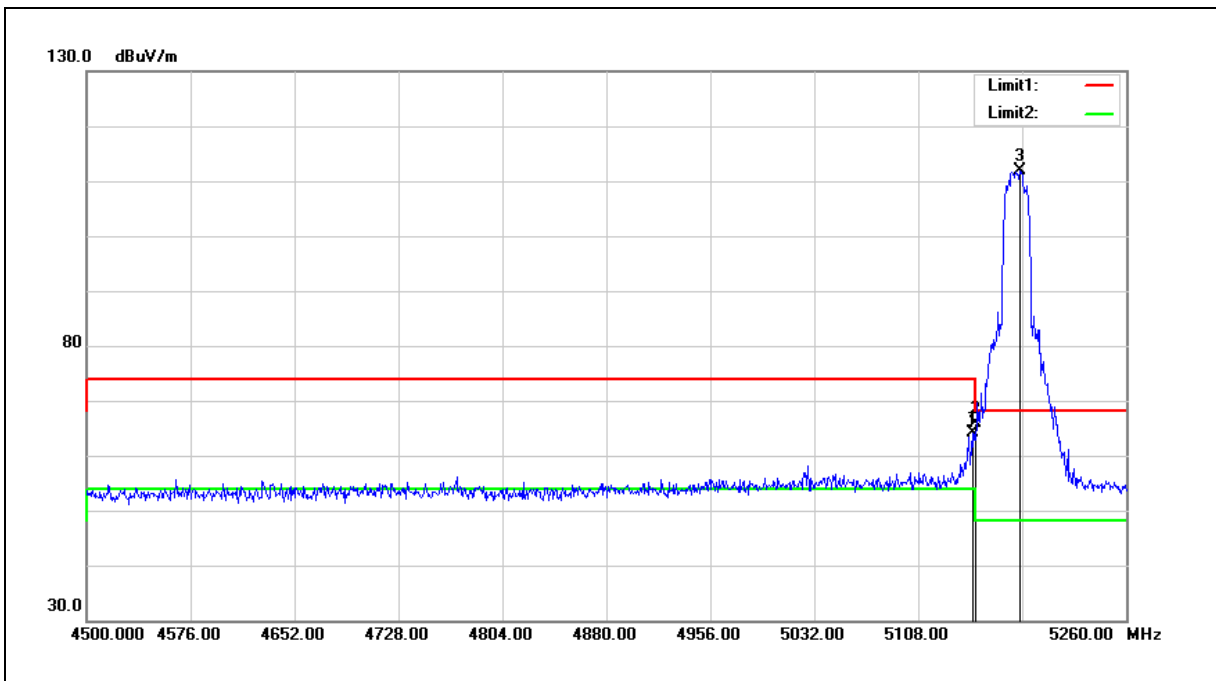

No.	Frequency (MHz)	Reading (dBuV)	Correct Factor (dB/m)	Result (dBuV/m)	Limit (dBuV/m)	Margin (dB)	Remark
1	5147.520	59.36	4.80	64.16	74.00	-9.84	peak
2	5150.000	61.02	4.80	65.82	74.00	-8.18	peak
3	5182.480	106.91	4.85	111.76	68.20	43.56	peak

Note:1.Result (dBuV/m) = Correct Factor (dB/m) + Reading(dBuV).

2.Correction factor (dB/m) = Antenna Factor (dB/m) + Cable loss (dB) – Pre-Amplifier gain (dB).

3.When the peak results are less than average limit, so not need to evaluate the average.

Standard:	FCC Part 15.407	Test Distance:	3 m
Test item:	Band edge		
Frequency:	5240 MHz		
Mode:	Mode 2		
Ant.Polar.:	Horizontal		

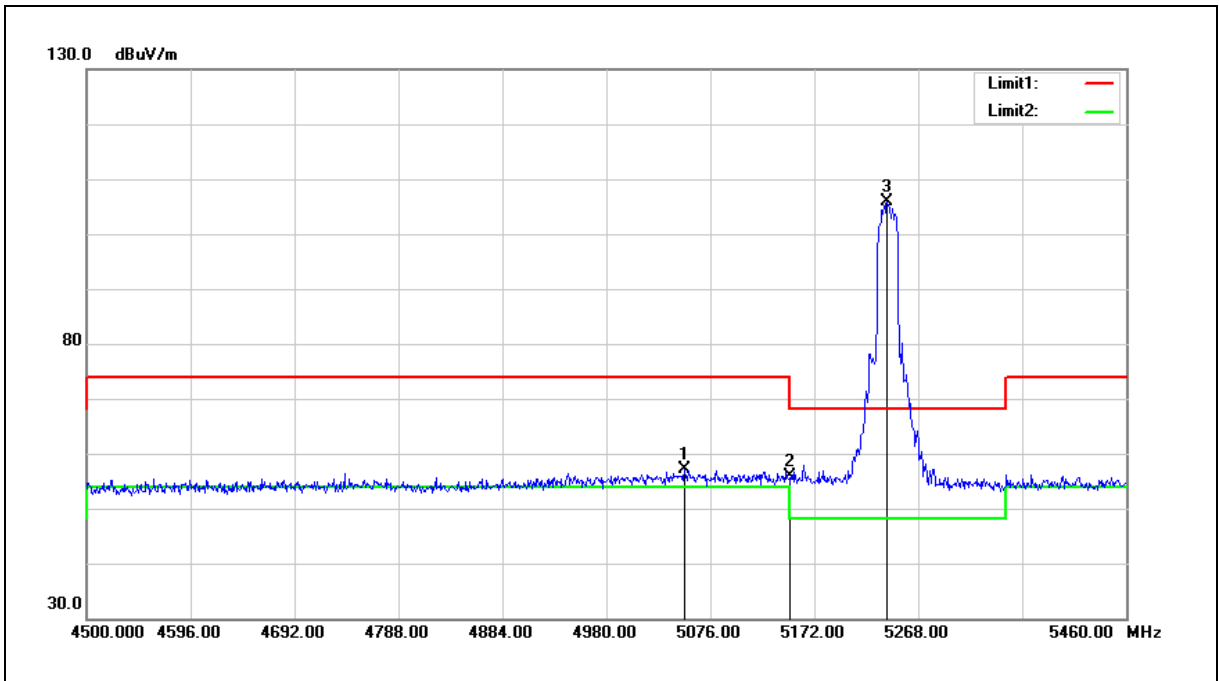

No.	Frequency (MHz)	Reading (dBuV)	Correct Factor (dB/m)	Result (dBuV/m)	Limit (dBuV/m)	Margin (dB)	Remark
1	5052.000	52.52	4.67	57.19	74.00	-16.81	peak
2	5150.000	51.18	4.80	55.98	74.00	-18.02	peak
3	5239.200	100.98	4.93	105.91	68.20	37.71	peak

Note:1.Result (dBuV/m) = Correct Factor (dB/m) + Reading(dBuV).

2.Correction factor (dB/m) = Antenna Factor (dB/m) + Cable loss (dB) – Pre-Amplifier gain (dB).

3.When the peak results are less than average limit, so not need to evaluate the average.

Standard:	FCC Part 15.407	Test Distance:	3 m
Test item:	Band edge		
Frequency:	5240 MHz		
Mode:	Mode 2		
Ant.Polar.:	Vertical		

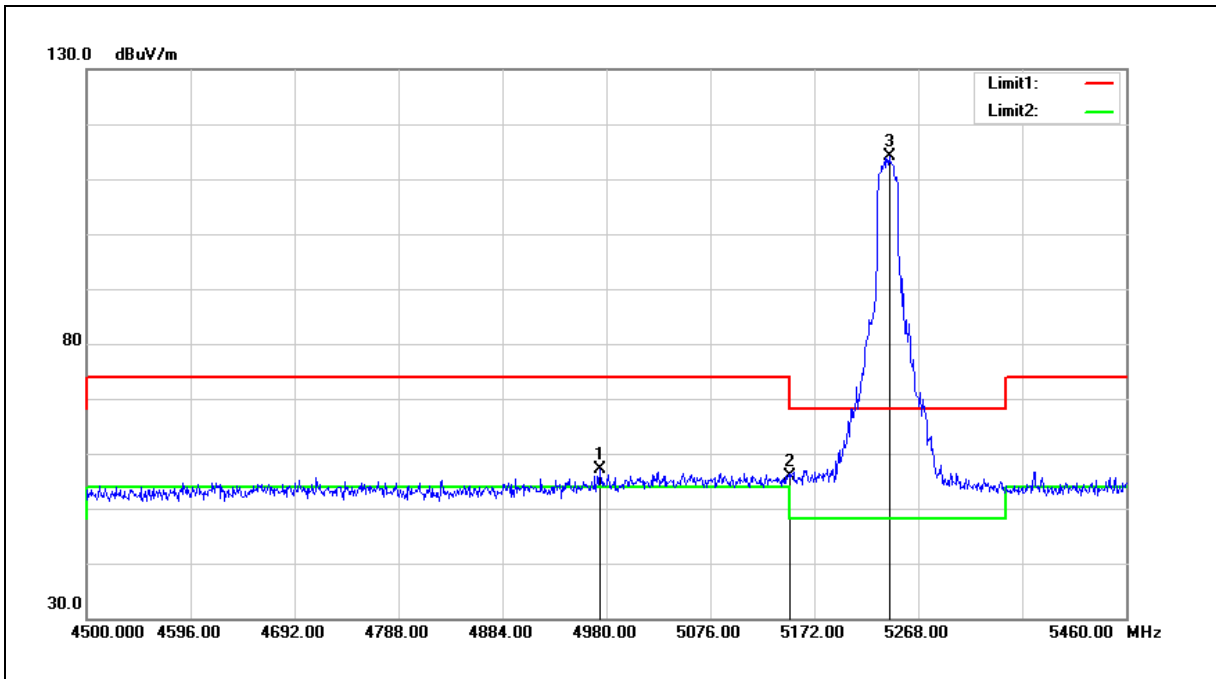

No.	Frequency (MHz)	Reading (dBuV)	Correct Factor (dB/m)	Result (dBuV/m)	Limit (dBuV/m)	Margin (dB)	Remark
1	4974.240	52.60	4.52	57.12	74.00	-16.88	peak
2	5150.000	51.01	4.80	55.81	74.00	-18.19	peak
3	5241.120	109.17	4.93	114.10	68.20	45.90	peak

Note:1.Result (dBuV/m) = Correct Factor (dB/m) + Reading(dBuV).

2.Correction factor (dB/m) = Antenna Factor (dB/m) + Cable loss (dB) – Pre-Amplifier gain (dB).

3.When the peak results are less than average limit, so not need to evaluate the average.

Standard:	FCC Part 15.407	Test Distance:	3 m
Test item:	Band edge		
Frequency:	5745 MHz		
Mode:	Mode 2		
Ant.Polar.:	Horizontal		

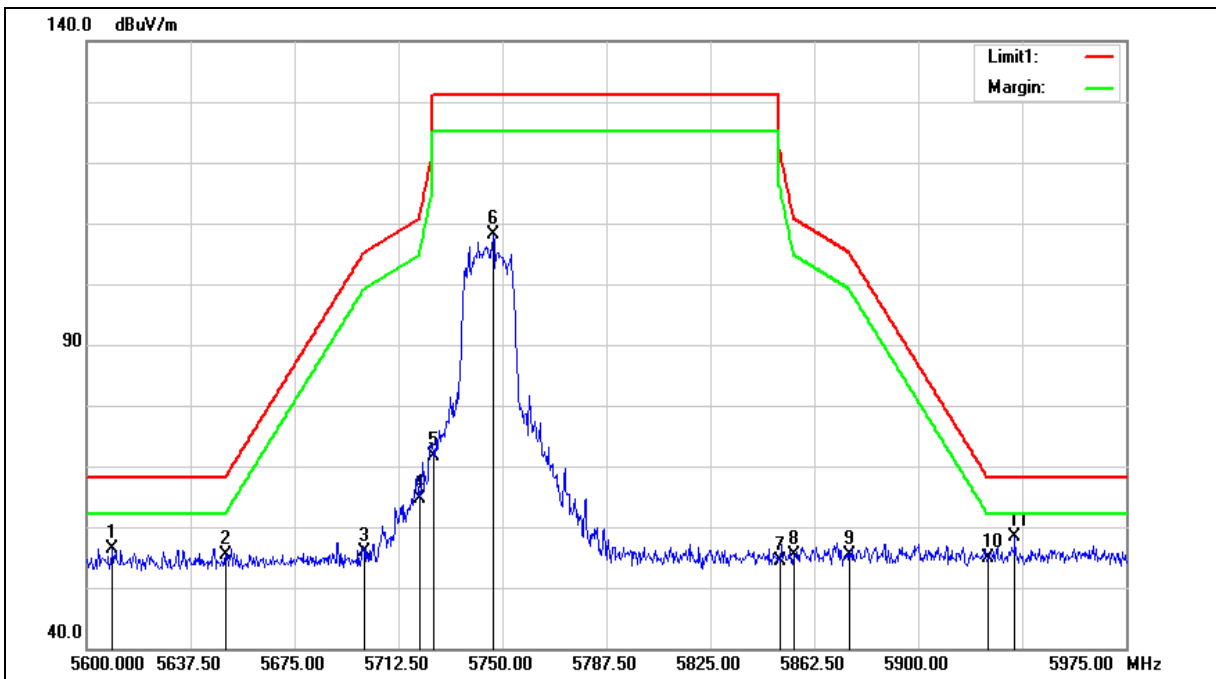

Standard:	FCC Part 15.407	Test Distance:	3 m
Test item:	Band edge		
Frequency:	5745 MHz		
Mode:	Mode 2		
Ant.Polar.:	Horizontal		

No.	Frequency (MHz)	Reading (dBuV)	Correct Factor (dB/m)	Result (dBuV/m)	Limit (dBuV/m)	Margin (dB)	Remark
1	5609.375	50.83	5.50	56.33	68.20	-11.87	peak
2	5650.000	49.87	5.58	55.45	68.20	-12.75	peak
3	5700.000	50.30	5.68	55.98	105.20	-49.22	peak
4	5720.000	58.90	5.72	64.62	110.80	-46.18	peak
5	5725.000	65.78	5.73	71.51	122.20	-50.69	peak
6	5746.625	102.27	5.78	108.05	131.20	-23.15	peak
7	5850.000	48.27	5.99	54.26	122.20	-67.94	peak
8	5855.000	49.41	6.00	55.41	110.80	-55.39	peak
9	5875.000	49.23	6.04	55.27	105.20	-49.93	peak
10	5925.000	48.74	6.13	54.87	68.20	-13.33	peak
11	5934.875	52.20	6.15	58.35	68.20	-9.85	peak

Note:1.Result (dBuV/m) = Correct Factor (dB/m) + Reading(dBuV).

2.Correction factor (dB/m) = Antenna Factor (dB/m) + Cable loss (dB) – Pre-Amplifier gain (dB).

3.When the peak results are less than average limit, so not need to evaluate the average.

Standard:	FCC Part 15.407	Test Distance:	3 m
Test item:	Band edge		
Frequency:	5745 MHz		
Mode:	Mode 2		
Ant.Polar.:	Vertical		

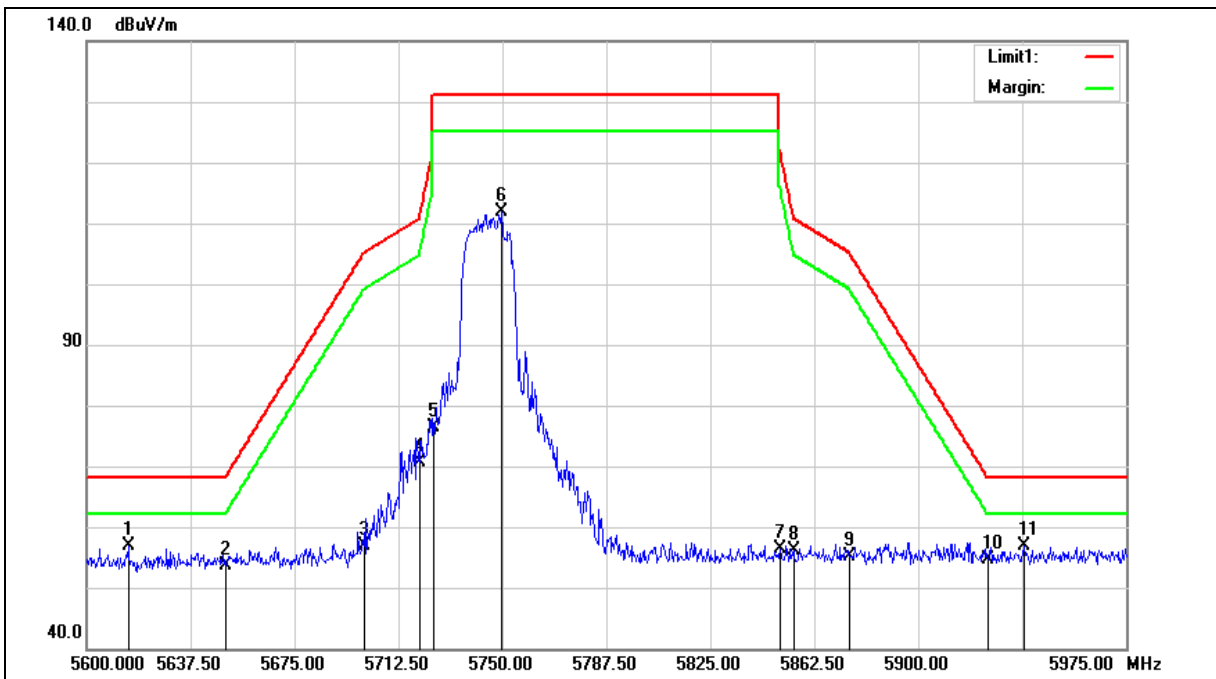

Standard:	FCC Part 15.407	Test Distance:	3 m
Test item:	Band edge		
Frequency:	5745 MHz		
Mode:	Mode 2		
Ant.Polar.:	Vertical		

No.	Frequency (MHz)	Reading (dBuV)	Correct Factor (dB/m)	Result (dBuV/m)	Limit (dBuV/m)	Margin (dB)	Remark
1	5615.000	51.36	5.52	56.88	68.20	-11.32	peak
2	5650.000	48.01	5.58	53.59	68.20	-14.61	peak
3	5700.000	51.30	5.68	56.98	105.20	-48.22	peak
4	5720.000	64.95	5.72	70.67	110.80	-40.13	peak
5	5725.000	70.54	5.73	76.27	122.20	-45.93	peak
6	5749.625	106.10	5.78	111.88	131.20	-19.32	peak
7	5850.000	50.29	5.99	56.28	122.20	-65.92	peak
8	5855.000	50.16	6.00	56.16	110.80	-54.64	peak
9	5875.000	49.01	6.04	55.05	105.20	-50.15	peak
10	5925.000	48.62	6.13	54.75	68.20	-13.45	peak
11	5938.250	50.79	6.16	56.95	68.20	-11.25	peak

Note:1.Result (dBuV/m) = Correct Factor (dB/m) + Reading(dBuV).

2.Correction factor (dB/m) = Antenna Factor (dB/m) + Cable loss (dB) – Pre-Amplifier gain (dB).

3.When the peak results are less than average limit, so not need to evaluate the average.

Standard:	FCC Part 15.407	Test Distance:	3 m
Test item:	Band edge		
Frequency:	5825 MHz		
Mode:	Mode 2		
Ant.Polar.:	Horizontal		

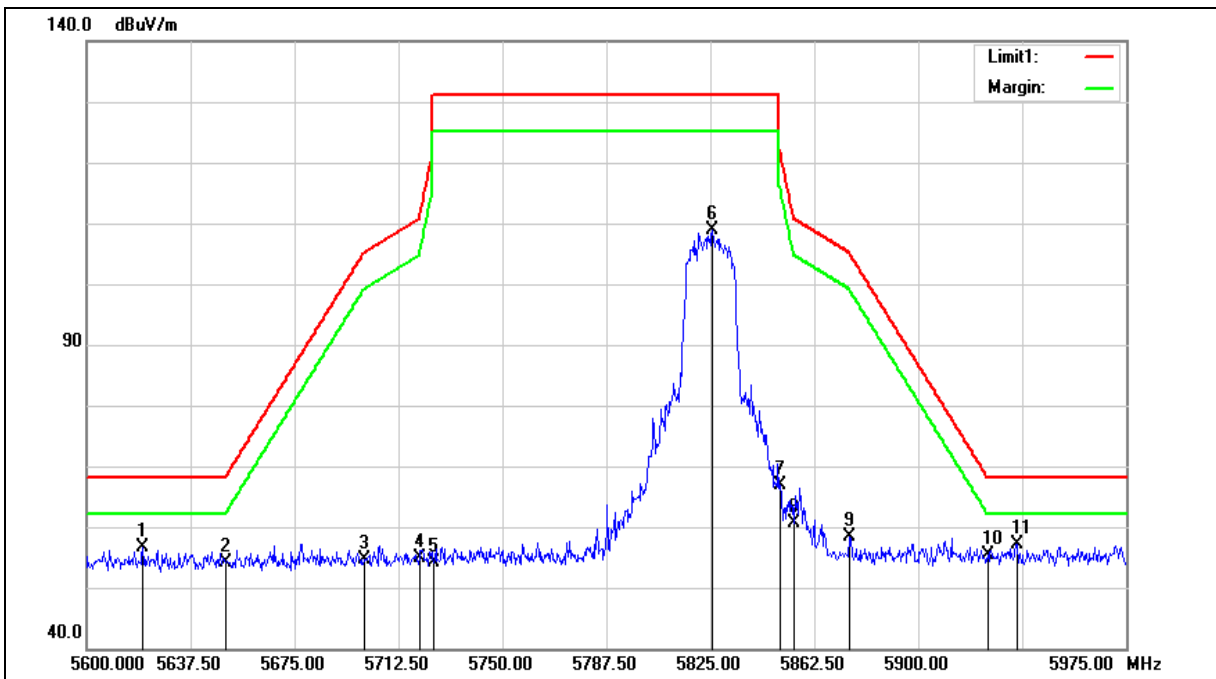

Standard:	FCC Part 15.407	Test Distance:	3 m
Test item:	Band edge		
Frequency:	5825 MHz		
Mode:	Mode 2		
Ant.Polar.:	Horizontal		

No.	Frequency (MHz)	Reading (dBuV)	Correct Factor (dB/m)	Result (dBuV/m)	Limit (dBuV/m)	Margin (dB)	Remark
1	5620.250	51.04	5.52	56.56	68.20	-11.64	peak
2	5650.000	48.57	5.58	54.15	68.20	-14.05	peak
3	5700.000	48.92	5.68	54.60	105.20	-50.60	peak
4	5720.000	49.22	5.72	54.94	110.80	-55.86	peak
5	5725.000	48.49	5.73	54.22	122.20	-67.98	peak
6	5825.750	102.96	5.93	108.89	131.20	-22.31	peak
7	5850.000	60.95	5.99	66.94	122.20	-55.26	peak
8	5855.000	54.62	6.00	60.62	110.80	-50.18	peak
9	5875.000	52.30	6.04	58.34	105.20	-46.86	peak
10	5925.000	49.27	6.13	55.40	68.20	-12.80	peak
11	5935.625	51.07	6.15	57.22	68.20	-10.98	peak

Note:1.Result (dBuV/m) = Correct Factor (dB/m) + Reading(dBuV).

2.Correction factor (dB/m) = Antenna Factor (dB/m) + Cable loss (dB) – Pre-Amplifier gain (dB).

3.When the peak results are less than average limit, so not need to evaluate the average.

Standard:	FCC Part 15.407	Test Distance:	3 m
Test item:	Band edge		
Frequency:	5825 MHz		
Mode:	Mode 2		
Ant.Polar.:	Vertical		

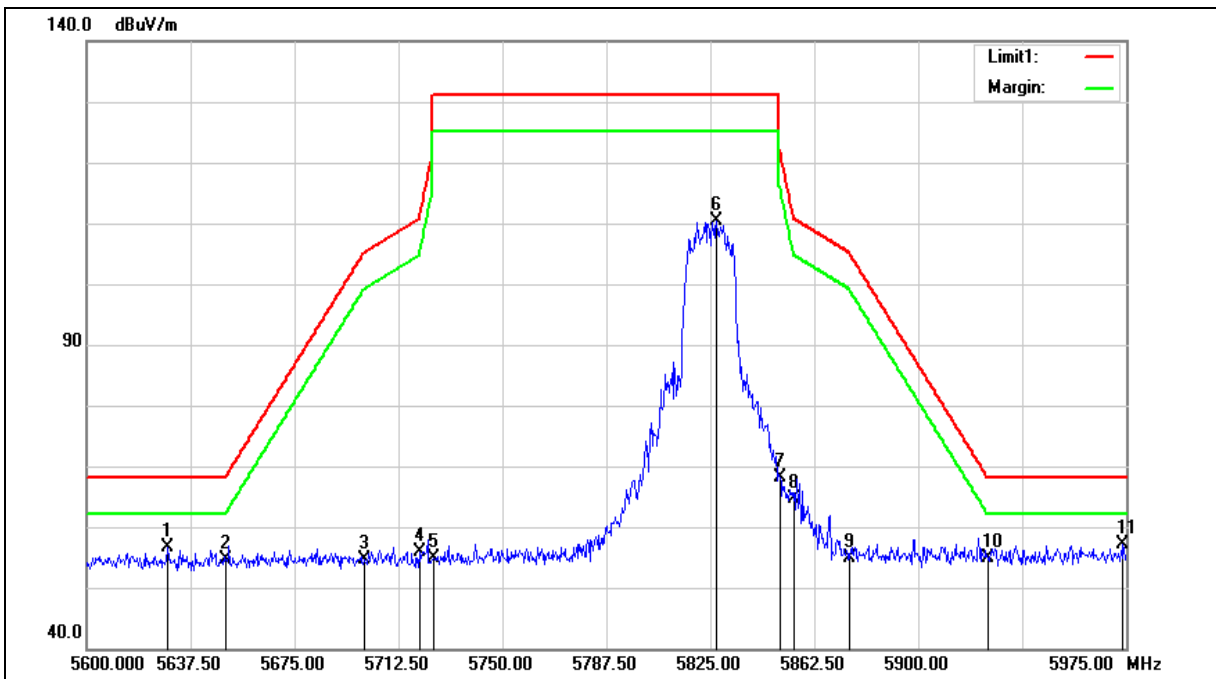

Standard:	FCC Part 15.407	Test Distance:	3 m
Test item:	Band edge		
Frequency:	5825 MHz		
Mode:	Mode 2		
Ant.Polar.:	Vertical		

No.	Frequency (MHz)	Reading (dBuV)	Correct Factor (dB/m)	Result (dBuV/m)	Limit (dBuV/m)	Margin (dB)	Remark
1	5629.250	51.15	5.55	56.70	68.20	-11.50	peak
2	5650.000	49.00	5.58	54.58	68.20	-13.62	peak
3	5700.000	48.91	5.68	54.59	105.20	-50.61	peak
4	5720.000	50.26	5.72	55.98	110.80	-54.82	peak
5	5725.000	49.18	5.73	54.91	122.20	-67.29	peak
6	5827.250	104.46	5.93	110.39	131.20	-20.81	peak
7	5850.000	62.07	5.99	68.06	122.20	-54.14	peak
8	5855.000	58.54	6.00	64.54	110.80	-46.26	peak
9	5875.000	48.80	6.04	54.84	105.20	-50.36	peak
10	5925.000	48.64	6.13	54.77	68.20	-13.43	peak
11	5973.875	51.00	6.23	57.23	68.20	-10.97	peak

Note:1.Result (dBuV/m) = Correct Factor (dB/m) + Reading(dBuV).

2.Correction factor (dB/m) = Antenna Factor (dB/m) + Cable loss (dB) – Pre-Amplifier gain (dB).

3.When the peak results are less than average limit, so not need to evaluate the average.

Average

Standard:	FCC Part 15.407	Test Distance:	3 m
Test item:	Band edge		
Frequency:	5180 MHz		
Mode:	Mode 1		
Ant.Polar.:	Horizontal		

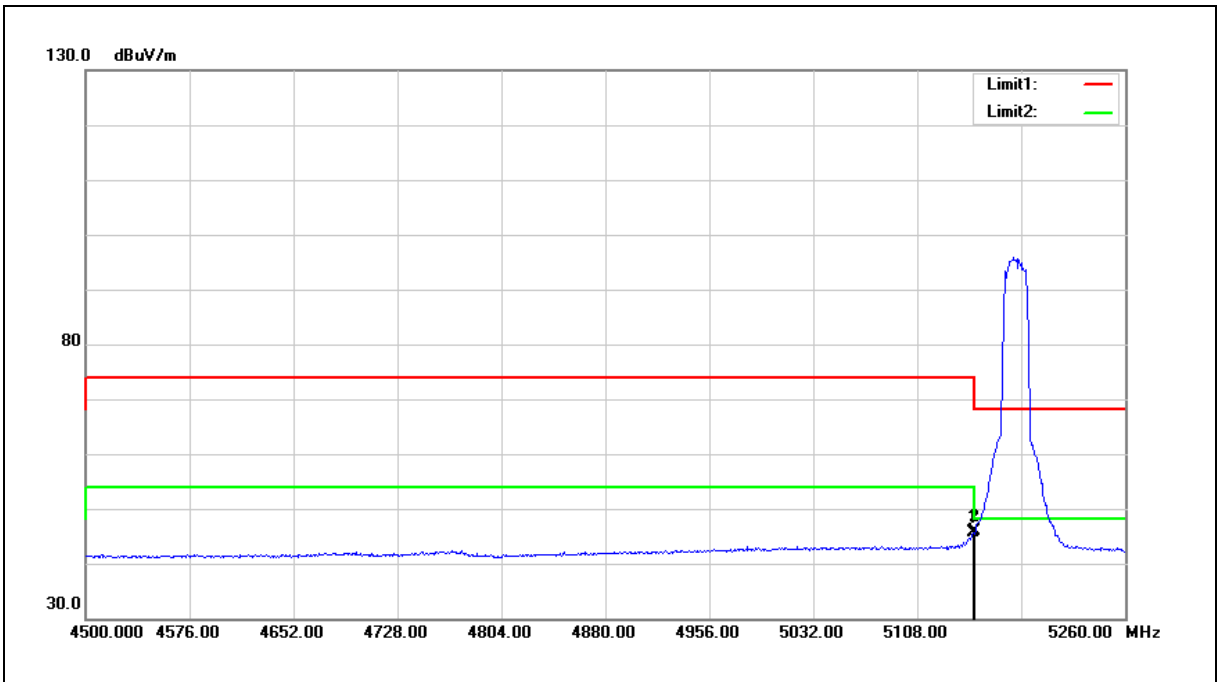

No.	Frequency (MHz)	Reading (dBuV)	Correct Factor (dB/m)	Result (dBuV/m)	Limit (dBuV/m)	Margin (dB)	Remark
1	5149.040	40.75	4.80	45.55	54.00	-8.45	AVG
2	5150.000	40.97	4.80	45.77	54.00	-8.23	AVG

- Note:1.Result (dBuV/m) = Correct Factor (dB/m) + Reading(dBuV).
- 2.Correction factor (dB/m) = Antenna Factor (dB/m) + Cable loss (dB) – Pre-Amplifier gain (dB).
- 3.When the peak results are less than average limit, so not need to evaluate the average.

Standard:	FCC Part 15.407	Test Distance:	3 m
Test item:	Band edge		
Frequency:	5180 MHz		
Mode:	Mode 1		
Ant.Polar.:	Vertical		

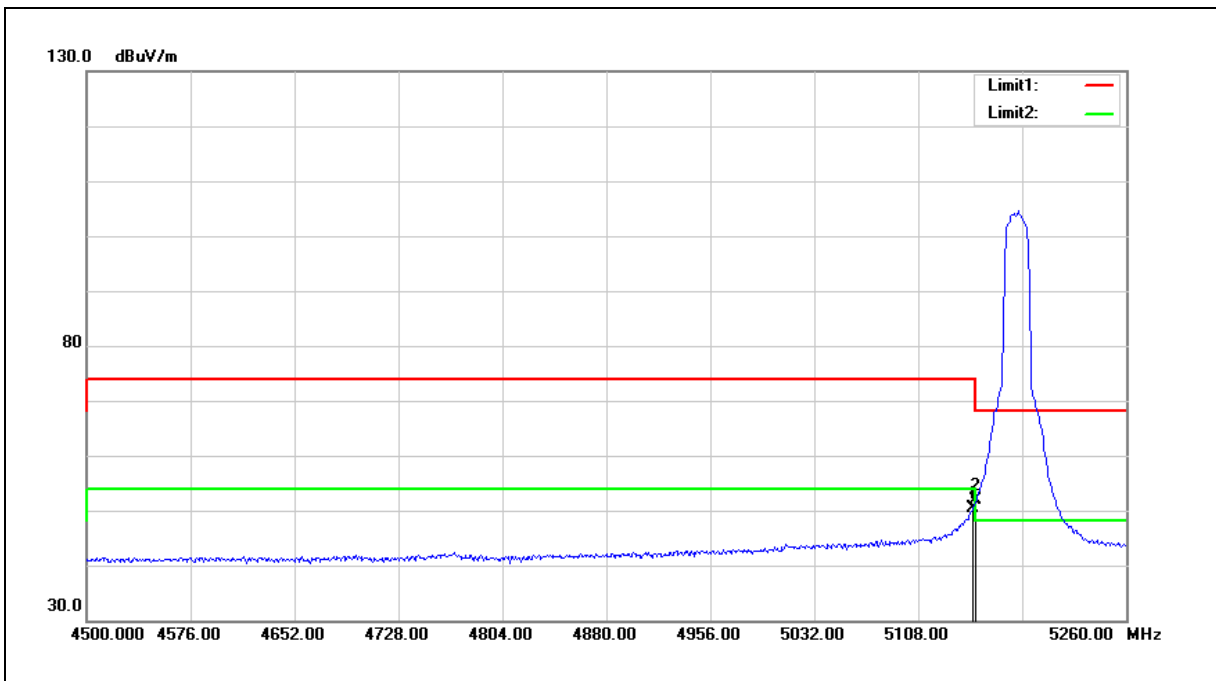

No.	Frequency (MHz)	Reading (dBuV)	Correct Factor (dB/m)	Result (dBuV/m)	Limit (dBuV/m)	Margin (dB)	Remark
1	5148.280	45.60	4.80	50.40	54.00	-3.60	AVG
2	5150.000	47.18	4.80	51.98	54.00	-2.02	AVG

- Note:1.Result (dBuV/m) = Correct Factor (dB/m) + Reading(dBuV).
 2.Correction factor (dB/m) = Antenna Factor (dB/m) + Cable loss (dB) – Pre-Amplifier gain (dB).
 3.When the peak results are less than average limit, so not need to evaluate the average.

Standard:	FCC Part 15.407	Test Distance:	3 m
Test item:	Band edge		
Frequency:	5240 MHz		
Mode:	Mode 1		
Ant.Polar.:	Horizontal		

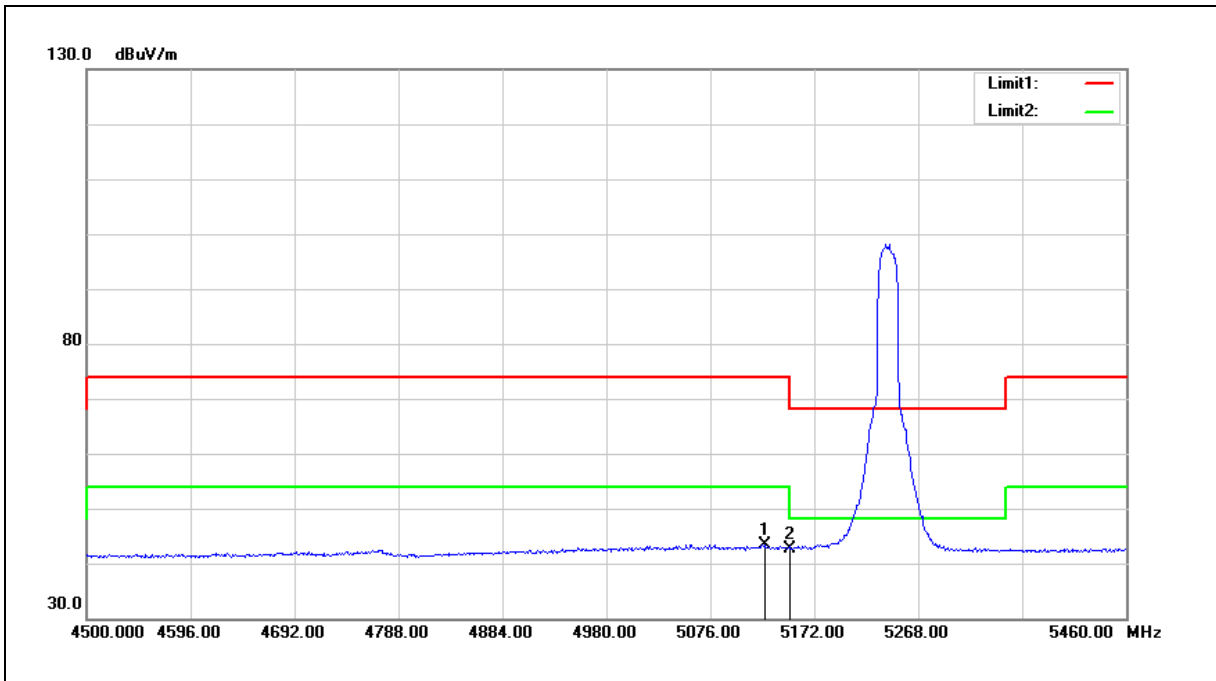

No.	Frequency (MHz)	Reading (dBuV)	Correct Factor (dB/m)	Result (dBuV/m)	Limit (dBuV/m)	Margin (dB)	Remark
1	5125.920	38.59	4.77	43.36	54.00	-10.64	AVG
2	5150.000	37.92	4.80	42.72	54.00	-11.28	AVG

Note:1.Result (dBuV/m) = Correct Factor (dB/m) + Reading(dBuV).

2.Correction factor (dB/m) = Antenna Factor (dB/m) + Cable loss (dB) – Pre-Amplifier gain (dB).

3.When the peak results are less than average limit, so not need to evaluate the average.

Standard:	FCC Part 15.407	Test Distance:	3 m
Test item:	Band edge		
Frequency:	5240 MHz		
Mode:	Mode 1		
Ant.Polar.:	Vertical		

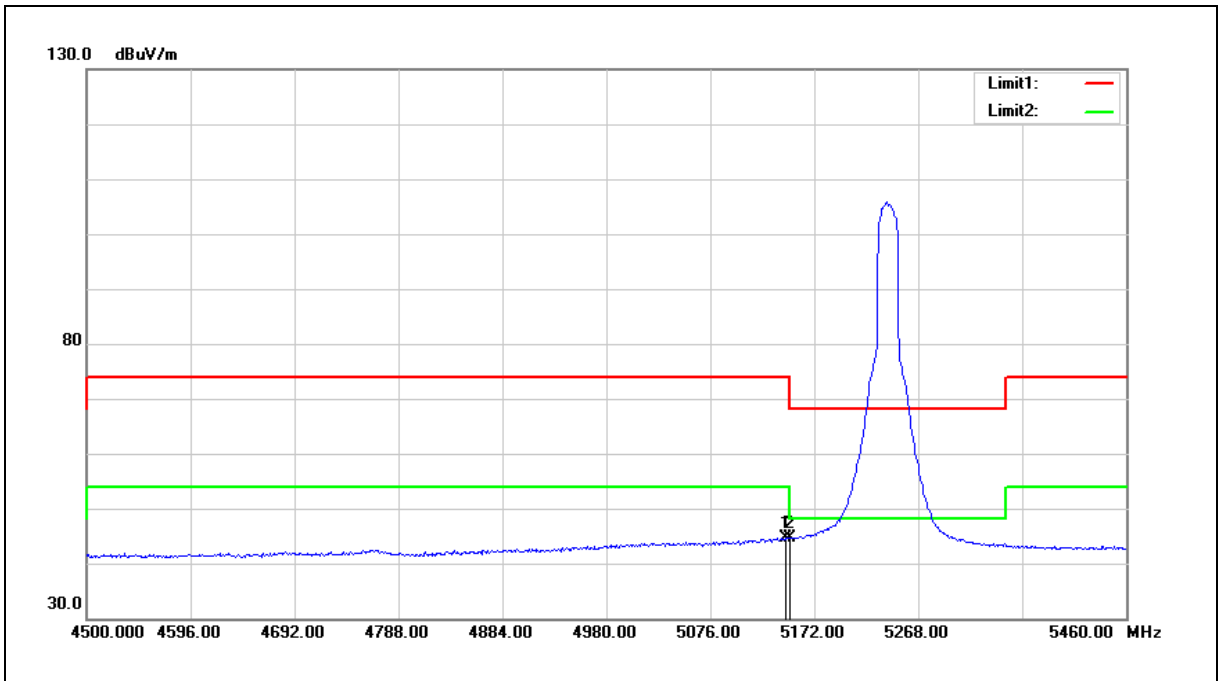

No.	Frequency (MHz)	Reading (dBuV)	Correct Factor (dB/m)	Result (dBuV/m)	Limit (dBuV/m)	Margin (dB)	Remark
1	5145.120	39.93	4.80	44.73	54.00	-9.27	AVG
2	5150.000	39.77	4.80	44.57	54.00	-9.43	AVG

Note:1.Result (dBuV/m) = Correct Factor (dB/m) + Reading(dBuV).

2.Correction factor (dB/m) = Antenna Factor (dB/m) + Cable loss (dB) – Pre-Amplifier gain (dB).

3.When the peak results are less than average limit, so not need to evaluate the average.

Standard:	FCC Part 15.407	Test Distance:	3 m
Test item:	Band edge		
Frequency:	5180 MHz		
Mode:	Mode 2		
Ant.Polar.:	Horizontal		

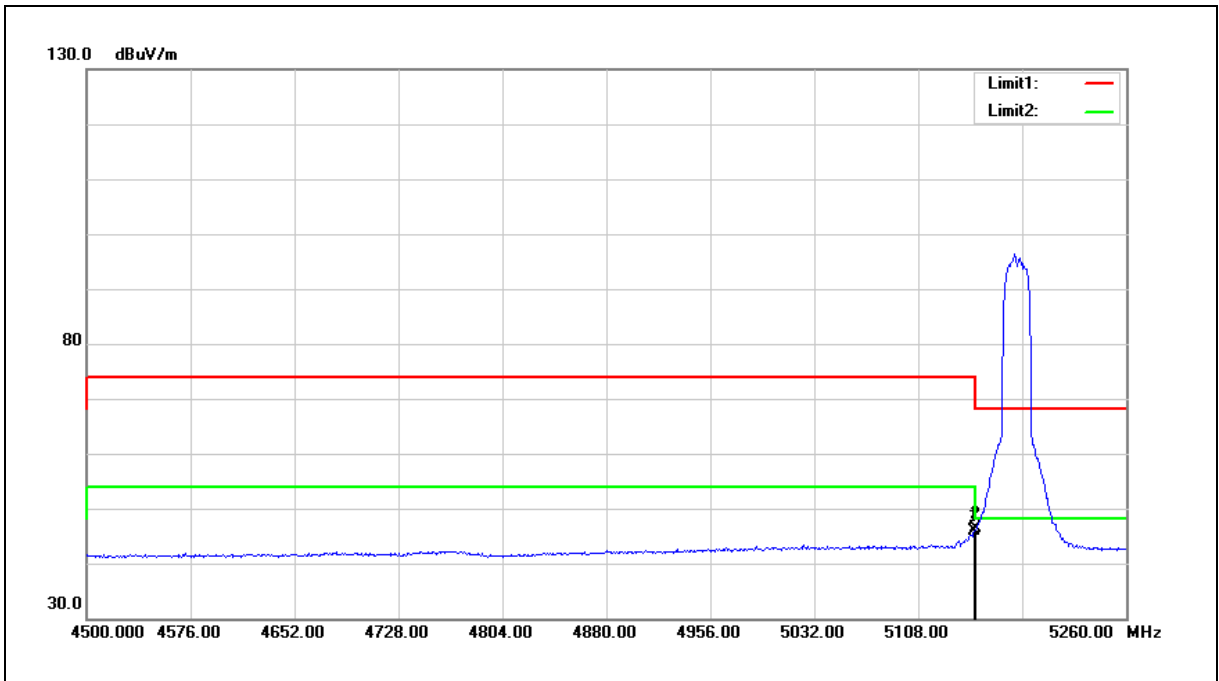

No.	Frequency (MHz)	Reading (dBuV)	Correct Factor (dB/m)	Result (dBuV/m)	Limit (dBuV/m)	Margin (dB)	Remark
1	5149.040	41.18	4.80	45.98	54.00	-8.02	AVG
2	5150.000	41.63	4.80	46.43	54.00	-7.57	AVG

- Note: 1. Result (dBuV/m) = Correct Factor (dB/m) + Reading (dBuV).
 2. Correction factor (dB/m) = Antenna Factor (dB/m) + Cable loss (dB) – Pre-Amplifier gain (dB).
 3. When the peak results are less than average limit, so not need to evaluate the average.

Standard:	FCC Part 15.407	Test Distance:	3 m
Test item:	Band edge		
Frequency:	5180 MHz		
Mode:	Mode 2		
Ant.Polar.:	Vertical		

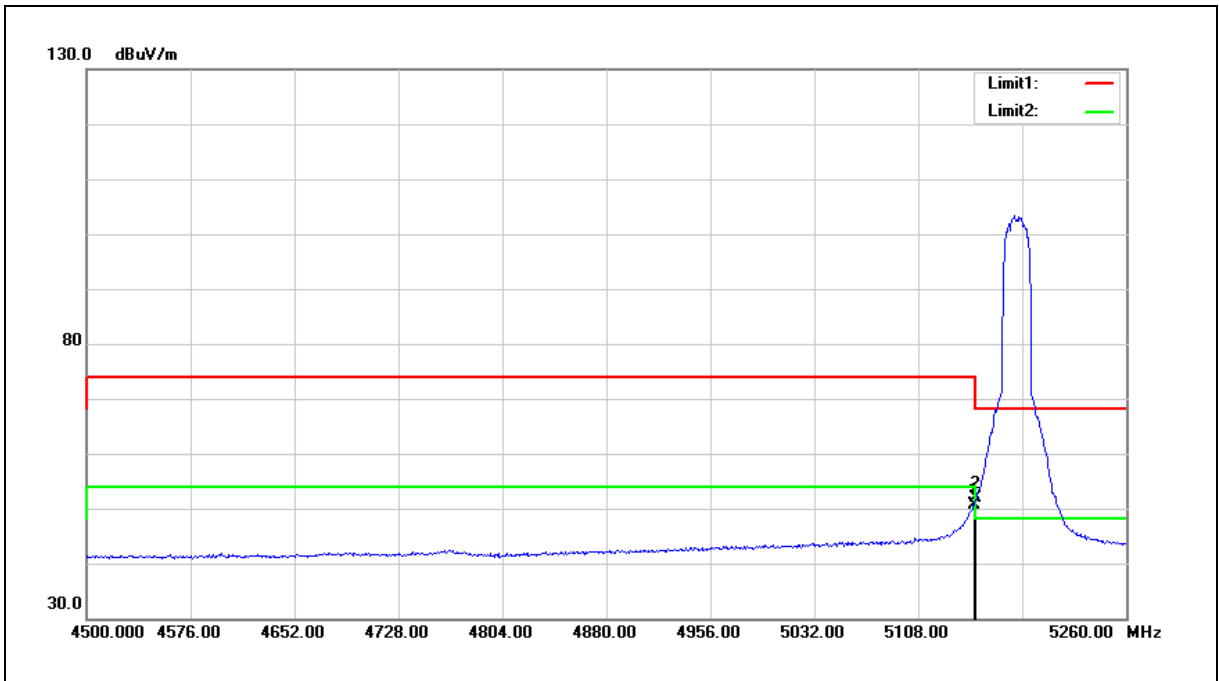

No.	Frequency (MHz)	Reading (dBuV)	Correct Factor (dB/m)	Result (dBuV/m)	Limit (dBuV/m)	Margin (dB)	Remark
1	5149.040	45.87	4.80	50.67	54.00	-3.33	AVG
2	5150.000	46.97	4.80	51.77	54.00	-2.23	AVG

Note:1.Result (dBuV/m) = Correct Factor (dB/m) + Reading(dBuV).

2.Correction factor (dB/m) = Antenna Factor (dB/m) + Cable loss (dB) – Pre-Amplifier gain (dB).

3.When the peak results are less than average limit, so not need to evaluate the average.

Standard:	FCC Part 15.407	Test Distance:	3 m
Test item:	Band edge		
Frequency:	5240 MHz		
Mode:	Mode 2		
Ant.Polar.:	Horizontal		

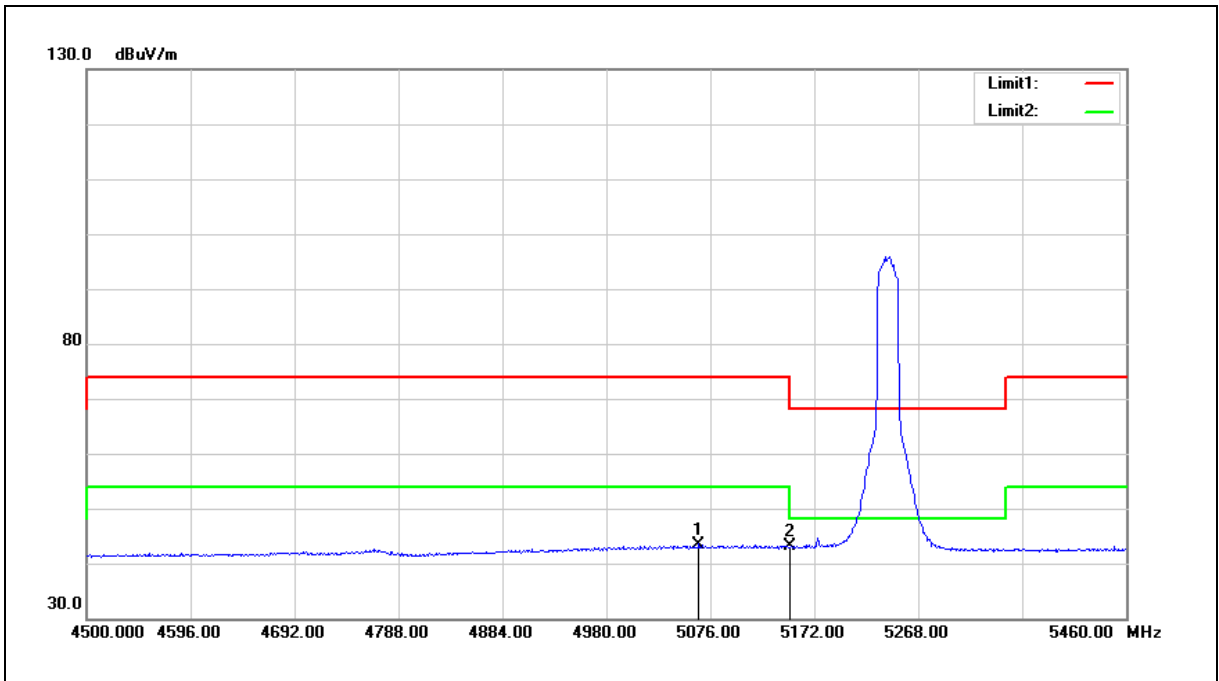

No.	Frequency (MHz)	Reading (dBuV)	Correct Factor (dB/m)	Result (dBuV/m)	Limit (dBuV/m)	Margin (dB)	Remark
1	5065.440	38.81	4.69	43.50	54.00	-10.50	AVG
2	5150.000	38.22	4.80	43.02	54.00	-10.98	AVG

Note:1.Result (dBuV/m) = Correct Factor (dB/m) + Reading(dBuV).

2.Correction factor (dB/m) = Antenna Factor (dB/m) + Cable loss (dB) – Pre-Amplifier gain (dB).

3.When the peak results are less than average limit, so not need to evaluate the average.

Standard:	FCC Part 15.407	Test Distance:	3 m
Test item:	Band edge		
Frequency:	5240 MHz		
Mode:	Mode 2		
Ant.Polar.:	Vertical		

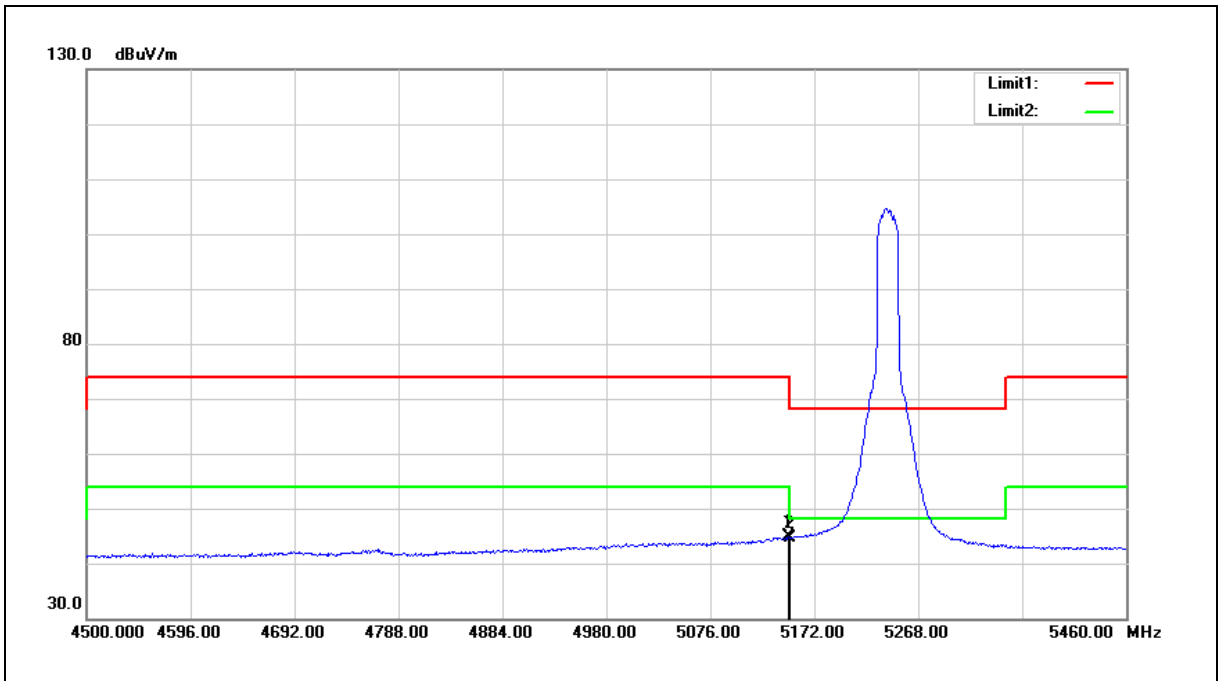

No.	Frequency (MHz)	Reading (dBuV)	Correct Factor (dB/m)	Result (dBuV/m)	Limit (dBuV/m)	Margin (dB)	Remark
1	5148.000	39.96	4.80	44.76	54.00	-9.24	AVG
2	5150.000	39.82	4.80	44.62	54.00	-9.38	AVG

Note:1.Result (dBuV/m) = Correct Factor (dB/m) + Reading(dBuV).

2.Correction factor (dB/m) = Antenna Factor (dB/m) + Cable loss (dB) – Pre-Amplifier gain (dB).

3.When the peak results are less than average limit, so not need to evaluate the average.

FPC Dipole Antenna

Below 1 GHz

Standard:	FCC Part 15.407	Test Distance:	3 m
Test item:	Radiated Emission		
Frequency:	5180 MHz		
Mode:	Mode 1		
Ant.Polar.:	Horizontal		

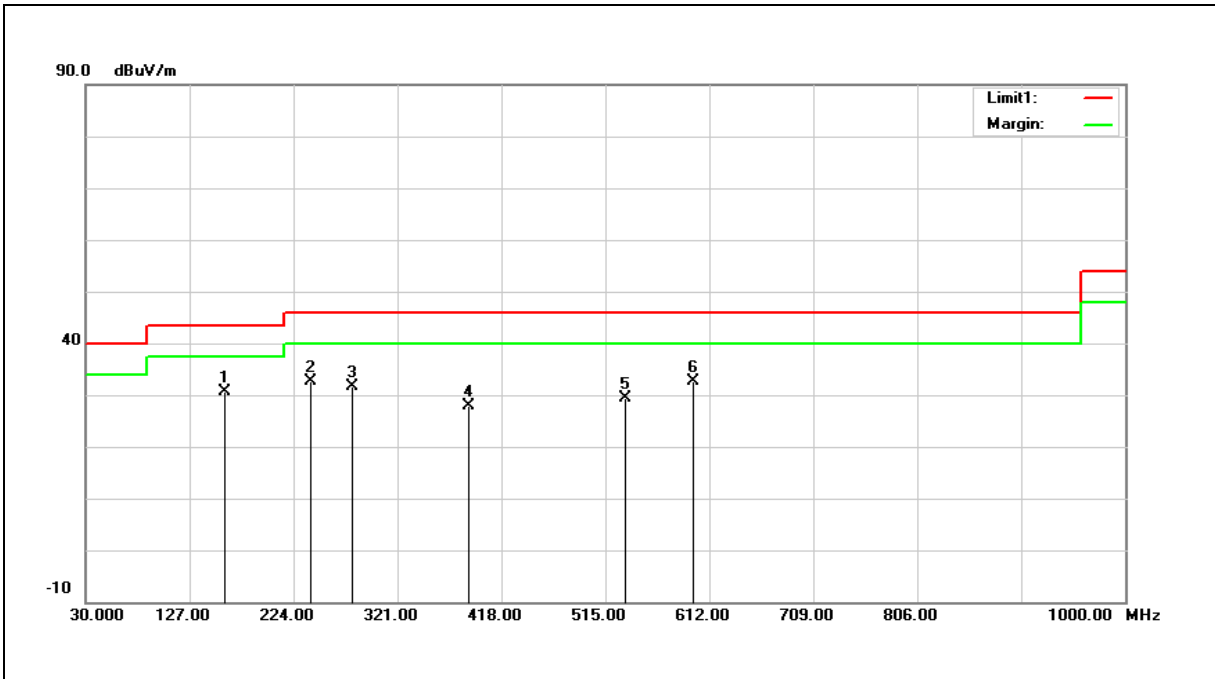

No.	Frequency (MHz)	Reading (dBuV)	Correct Factor (dB/m)	Result (dBuV/m)	Limit (dBuV/m)	Margin (dB)	Remark
1	159.9800	37.41	-6.76	30.65	43.50	-12.85	QP
2	240.4900	40.83	-8.15	32.68	46.00	-13.32	QP
3	279.2900	38.35	-6.69	31.66	46.00	-14.34	QP
4	386.9600	32.25	-4.32	27.93	46.00	-18.07	QP
5	533.4300	30.72	-1.41	29.31	46.00	-16.69	QP
6	597.4500	32.10	0.56	32.66	46.00	-13.34	QP

Note:1.Result (dBuV/m) = Correct Factor (dB/m) + Reading(dBuV).

2.Correction factor (dB/m) = Antenna Factor (dB/m) + Cable loss (dB) – Pre-Amplifier gain (dB).

3.When the peak results are less than average limit, so not need to evaluate the average.

Standard:	FCC Part 15.407	Test Distance:	3 m
Test item:	Radiated Emission		
Frequency:	5180 MHz		
Mode:	Mode 1		
Ant.Polar.:	Vertical		

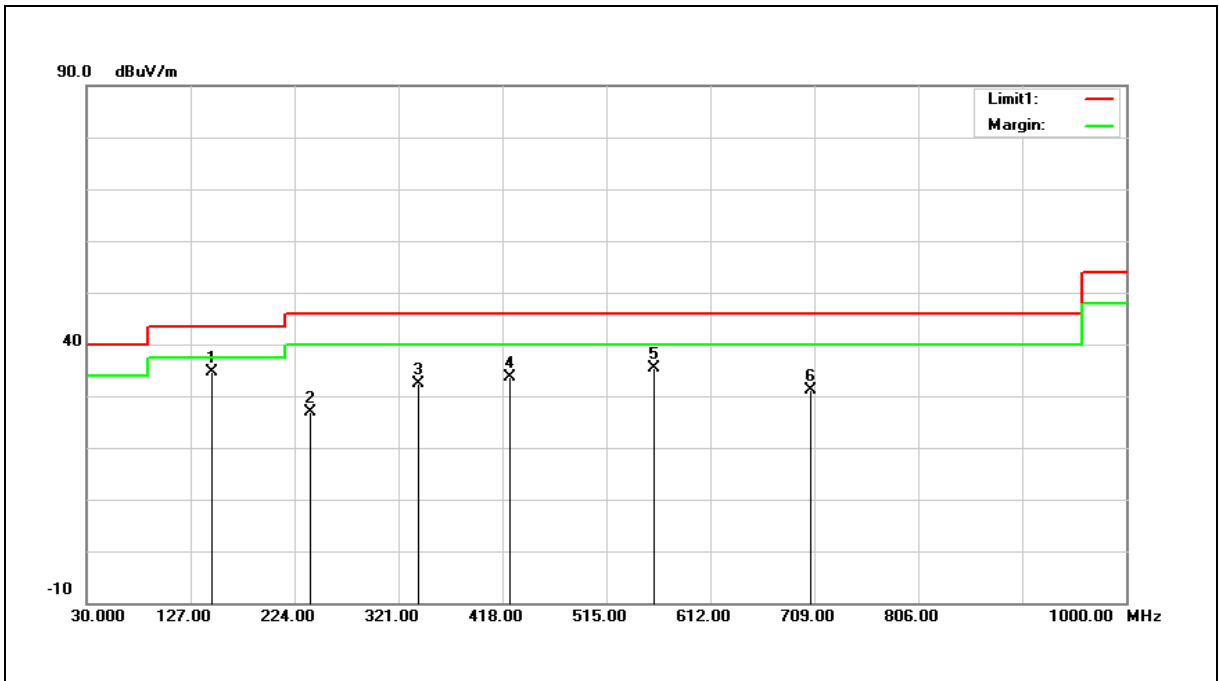

No.	Frequency (MHz)	Reading (dBuV)	Correct Factor (dB/m)	Result (dBuV/m)	Limit (dBuV/m)	Margin (dB)	Remark
1	147.3700	41.68	-7.10	34.58	43.50	-8.92	QP
2	238.5500	35.22	-8.37	26.85	46.00	-19.15	QP
3	339.4300	38.16	-5.70	32.46	46.00	-13.54	QP
4	424.7900	36.90	-3.38	33.52	46.00	-12.48	QP
5	559.6200	36.18	-0.81	35.37	46.00	-10.63	QP
6	706.0900	28.68	2.56	31.24	46.00	-14.76	QP

Note:1.Result (dBuV/m) = Correct Factor (dB/m) + Reading(dBuV).

2.Correction factor (dB/m) = Antenna Factor (dB/m) + Cable loss (dB) – Pre-Amplifier gain (dB).

3.When the peak results are less than average limit, so not need to evaluate the average.

Harmonic

Above 1 GHz

Standard:	FCC Part 15.407	Test Distance:	3 m
Test item:	Harmonic		
Frequency:	5180 MHz		
Mode:	Mode 1		
Ant.Polar.:	Horizontal		

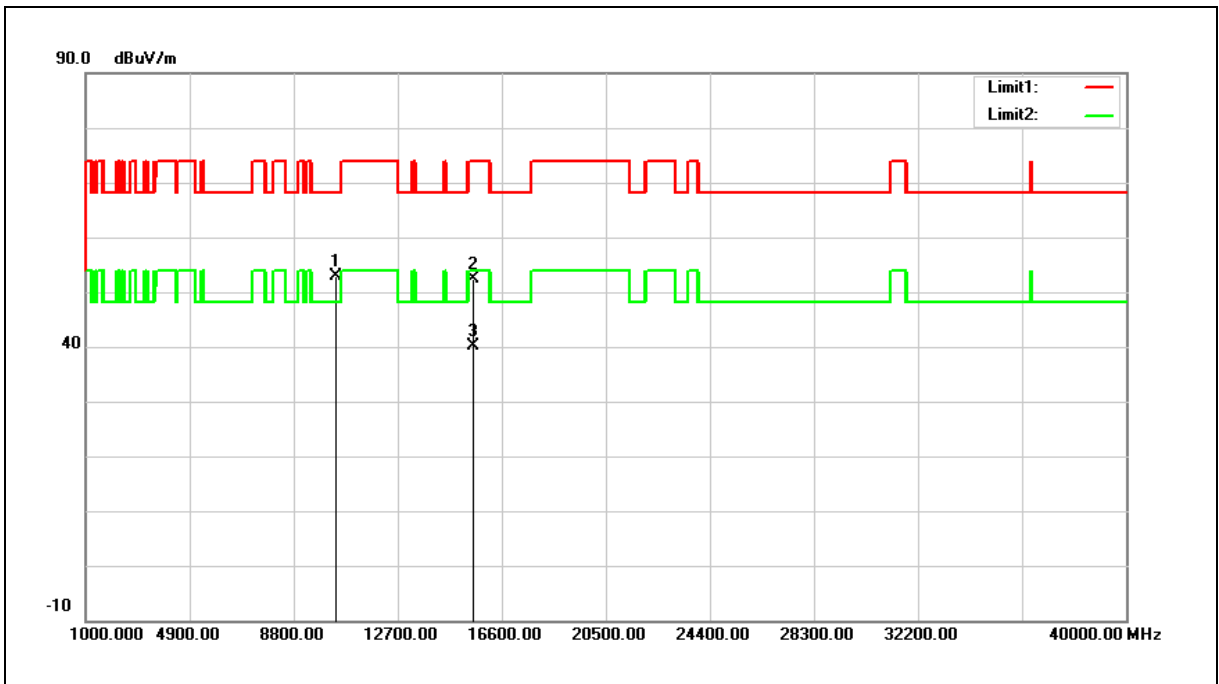

No.	Frequency (MHz)	Reading (dBuV)	Correct Factor (dB/m)	Result (dBuV/m)	Limit (dBuV/m)	Margin (dB)	Remark
1	10360.000	36.93	16.07	53.00	68.20	-15.20	peak
2	15540.000	34.42	18.03	52.45	74.00	-21.55	peak
3	15540.000	22.10	18.03	40.13	54.00	-13.87	AVG

Note:1.Result (dBuV/m) = Correct Factor (dB/m) + Reading(dBuV).

2.Correction factor (dB/m) = Antenna Factor (dB/m) + Cable loss (dB) – Pre-Amplifier gain (dB).

3.When the peak results are less than average limit, so not need to evaluate the average.

Standard:	FCC Part 15.407	Test Distance:	3 m
Test item:	Harmonic		
Frequency:	5180 MHz		
Mode:	Mode 1		
Ant.Polar.:	Vertical		

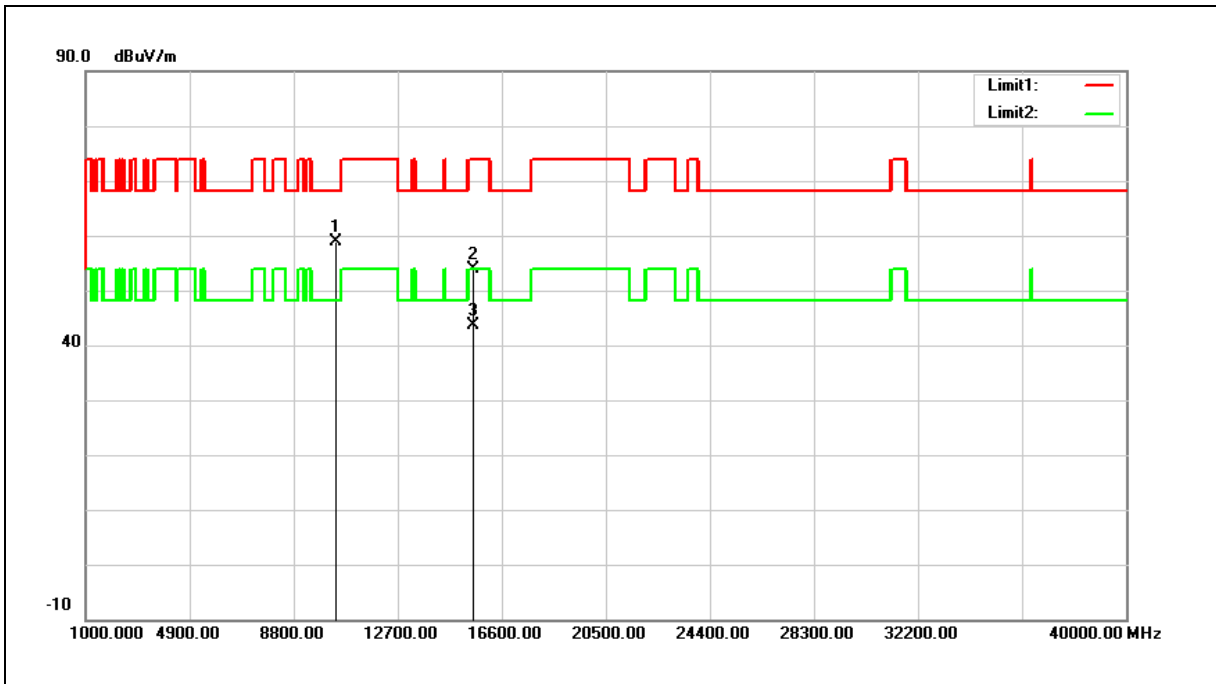

No.	Frequency (MHz)	Reading (dBuV)	Correct Factor (dB/m)	Result (dBuV/m)	Limit (dBuV/m)	Margin (dB)	Remark
1	10360.000	42.71	16.07	58.78	68.20	-9.42	peak
2	15540.000	35.91	18.03	53.94	74.00	-20.06	peak
3	15540.000	25.57	18.03	43.60	54.00	-10.40	AVG

Note:1.Result (dBuV/m) = Correct Factor (dB/m) + Reading(dBuV).

2.Correction factor (dB/m) = Antenna Factor (dB/m) + Cable loss (dB) – Pre-Amplifier gain (dB).

3.When the peak results are less than average limit, so not need to evaluate the average.

Standard:	FCC Part 15.407	Test Distance:	3 m
Test item:	Harmonic		
Frequency:	5200 MHz		
Mode:	Mode 1		
Ant.Polar.:	Horizontal		

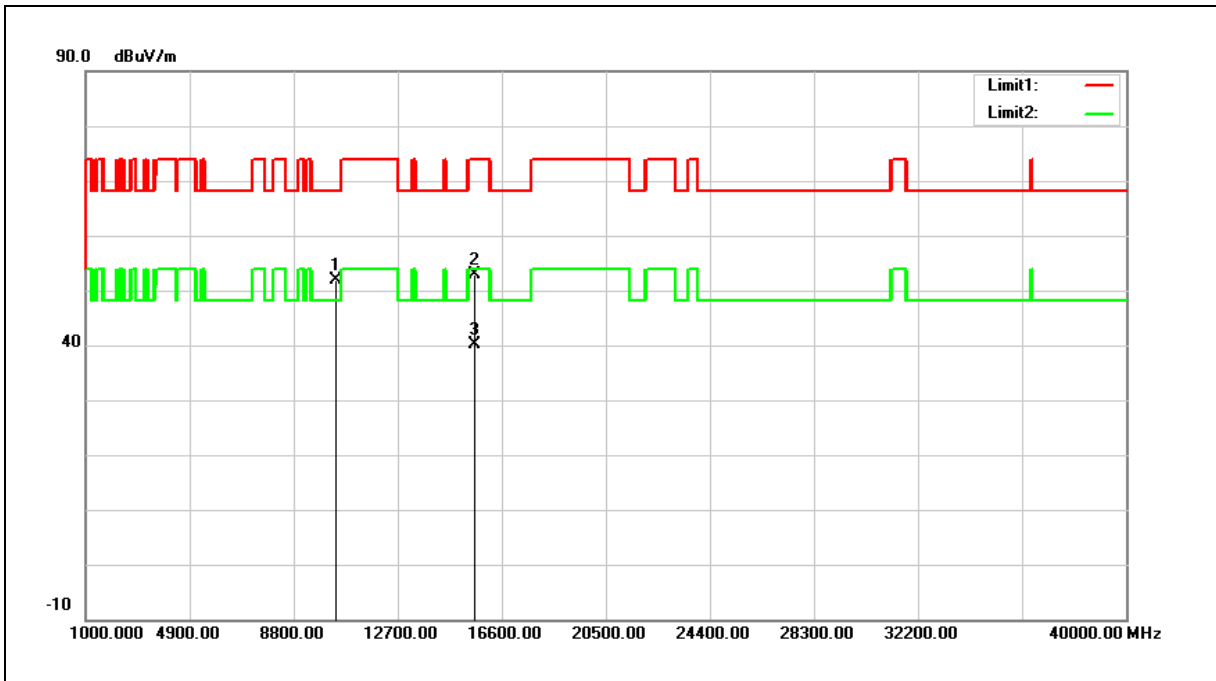

No.	Frequency (MHz)	Reading (dBuV)	Correct Factor (dB/m)	Result (dBuV/m)	Limit (dBuV/m)	Margin (dB)	Remark
1	10400.000	35.75	16.18	51.93	68.20	-16.27	peak
2	15600.000	35.22	17.76	52.98	74.00	-21.02	peak
3	15600.000	22.46	17.76	40.22	54.00	-13.78	AVG

Note:1.Result (dBuV/m) = Correct Factor (dB/m) + Reading(dBuV).

2.Correction factor (dB/m) = Antenna Factor (dB/m) + Cable loss (dB) – Pre-Amplifier gain (dB).

3.When the peak results are less than average limit, so not need to evaluate the average.

Standard:	FCC Part 15.407	Test Distance:	3 m
Test item:	Harmonic		
Frequency:	5200 MHz		
Mode:	Mode 1		
Ant.Polar.:	Vertical		

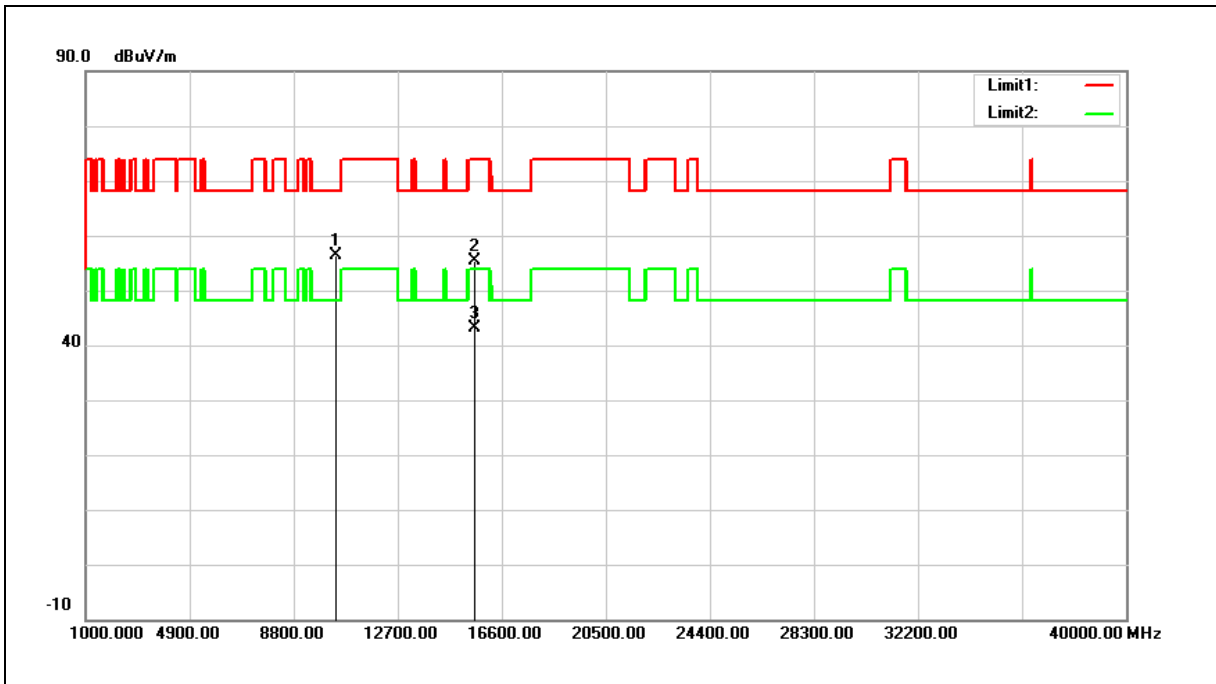

No.	Frequency (MHz)	Reading (dBuV)	Correct Factor (dB/m)	Result (dBuV/m)	Limit (dBuV/m)	Margin (dB)	Remark
1	10400.000	40.13	16.18	56.31	68.20	-11.89	peak
2	15600.000	37.64	17.76	55.40	74.00	-18.60	peak
3	15600.000	25.49	17.76	43.25	54.00	-10.75	AVG

Note:1.Result (dBuV/m) = Correct Factor (dB/m) + Reading(dBuV).

2.Correction factor (dB/m) = Antenna Factor (dB/m) + Cable loss (dB) – Pre-Amplifier gain (dB).

3.When the peak results are less than average limit, so not need to evaluate the average.

Standard:	FCC Part 15.407	Test Distance:	3 m
Test item:	Harmonic		
Frequency:	5240 MHz		
Mode:	Mode 1		
Ant.Polar.:	Horizontal		

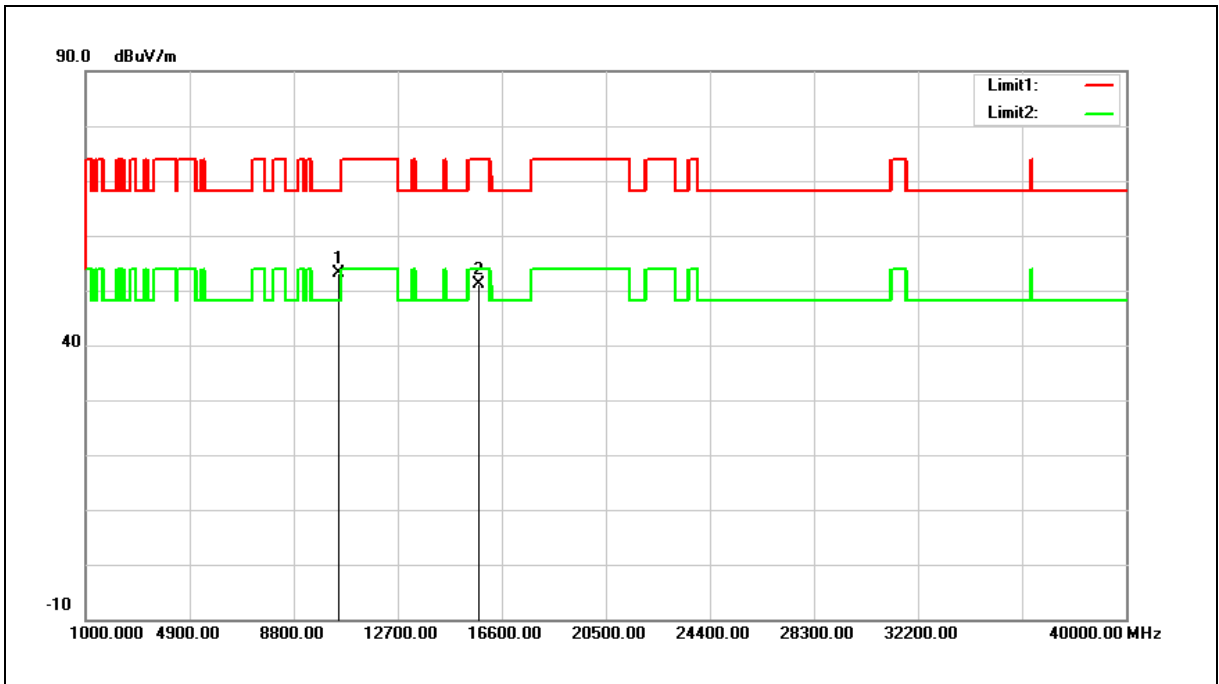

No.	Frequency (MHz)	Reading (dBuV)	Correct Factor (dB/m)	Result (dBuV/m)	Limit (dBuV/m)	Margin (dB)	Remark
1	10480.000	36.85	16.38	53.23	68.20	-14.97	peak
2	15720.000	33.90	17.22	51.12	74.00	-22.88	peak

Note:1.Result (dBuV/m) = Correct Factor (dB/m) + Reading(dBuV).

2.Correction factor (dB/m) = Antenna Factor (dB/m) + Cable loss (dB) – Pre-Amplifier gain (dB).

3.When the peak results are less than average limit, so not need to evaluate the average.

Standard:	FCC Part 15.407	Test Distance:	3 m
Test item:	Harmonic		
Frequency:	5240 MHz		
Mode:	Mode 1		
Ant.Polar.:	Vertical		

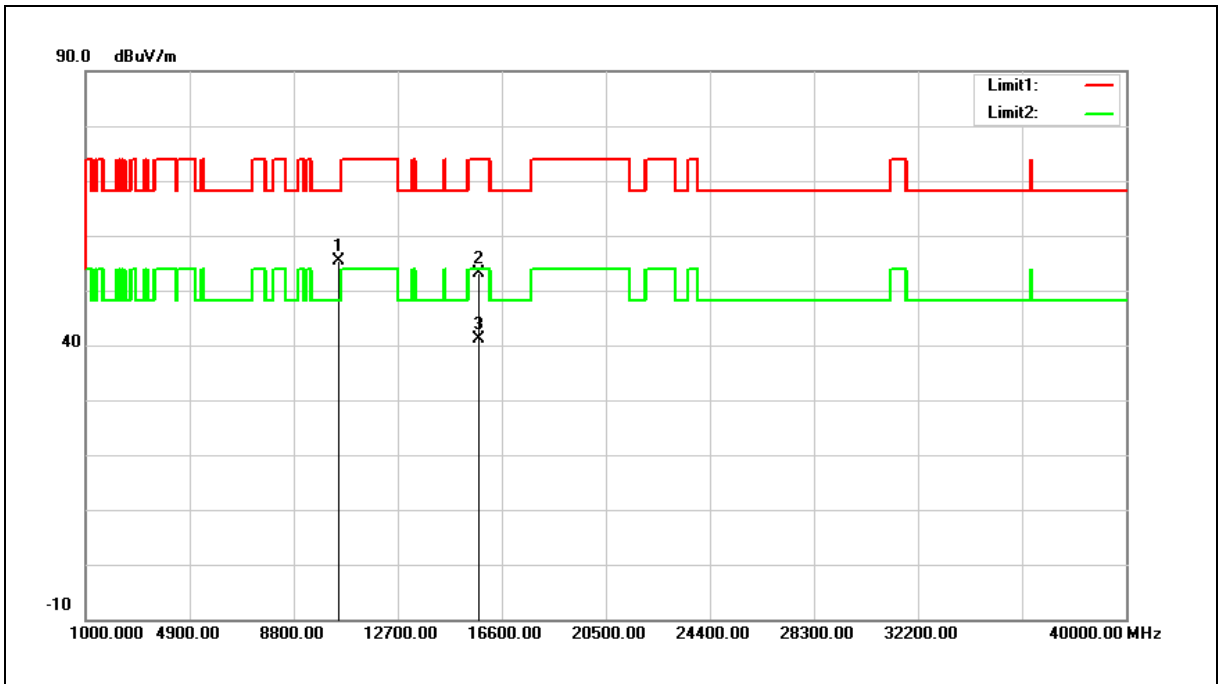

No.	Frequency (MHz)	Reading (dBuV)	Correct Factor (dB/m)	Result (dBuV/m)	Limit (dBuV/m)	Margin (dB)	Remark
1	10480.000	39.01	16.38	55.39	68.20	-12.81	peak
2	15720.000	36.01	17.22	53.23	74.00	-20.77	peak
3	15720.000	23.99	17.22	41.21	54.00	-12.79	AVG

Note:1.Result (dBuV/m) = Correct Factor (dB/m) + Reading(dBuV).

2.Correction factor (dB/m) = Antenna Factor (dB/m) + Cable loss (dB) – Pre-Amplifier gain (dB).

3.When the peak results are less than average limit, so not need to evaluate the average.

Standard:	FCC Part 15.407	Test Distance:	3 m
Test item:	Harmonic		
Frequency:	5745 MHz		
Mode:	Mode 1		
Ant.Polar.:	Horizontal		

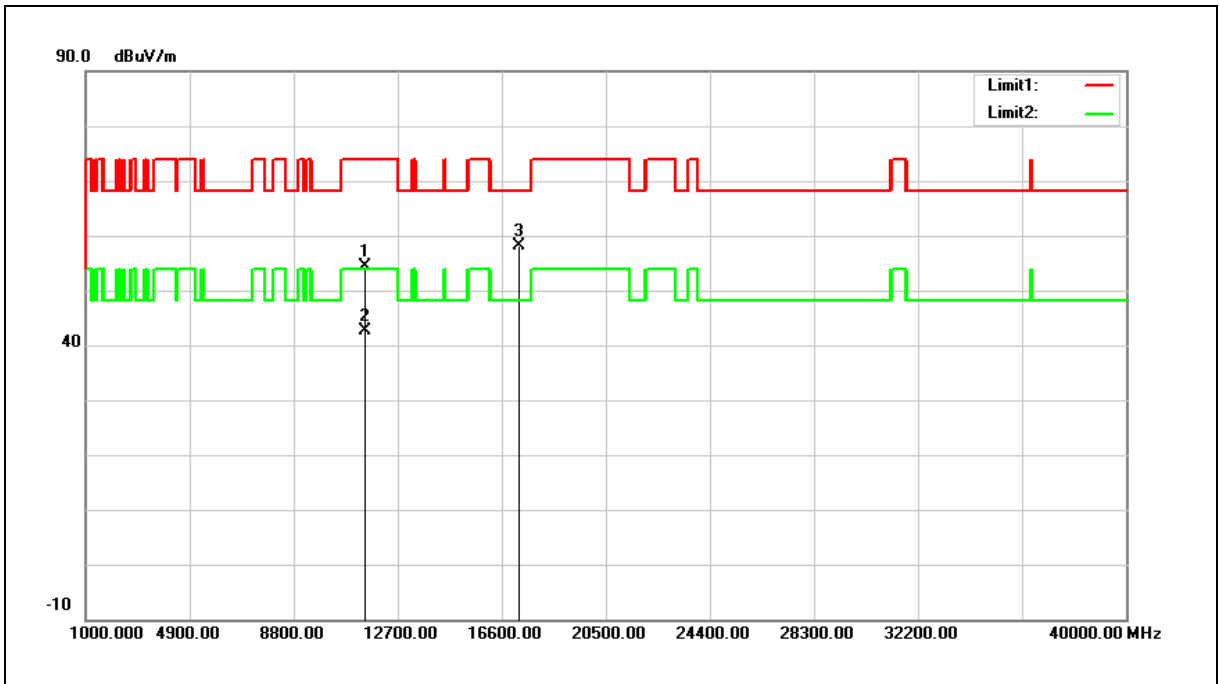

No.	Frequency (MHz)	Reading (dBuV)	Correct Factor (dB/m)	Result (dBuV/m)	Limit (dBuV/m)	Margin (dB)	Remark
1	11490.000	36.31	18.19	54.50	74.00	-19.50	peak
2	11490.000	24.38	18.19	42.57	54.00	-11.43	AVG
3	17235.000	34.76	23.43	58.19	68.20	-10.01	peak

Note:1.Result (dBuV/m) = Correct Factor (dB/m) + Reading(dBuV).

2.Correction factor (dB/m) = Antenna Factor (dB/m) + Cable loss (dB) – Pre-Amplifier gain (dB).

3.When the peak results are less than average limit, so not need to evaluate the average.

Standard:	FCC Part 15.407	Test Distance:	3 m
Test item:	Harmonic		
Frequency:	5745 MHz		
Mode:	Mode 1		
Ant.Polar.:	Vertical		

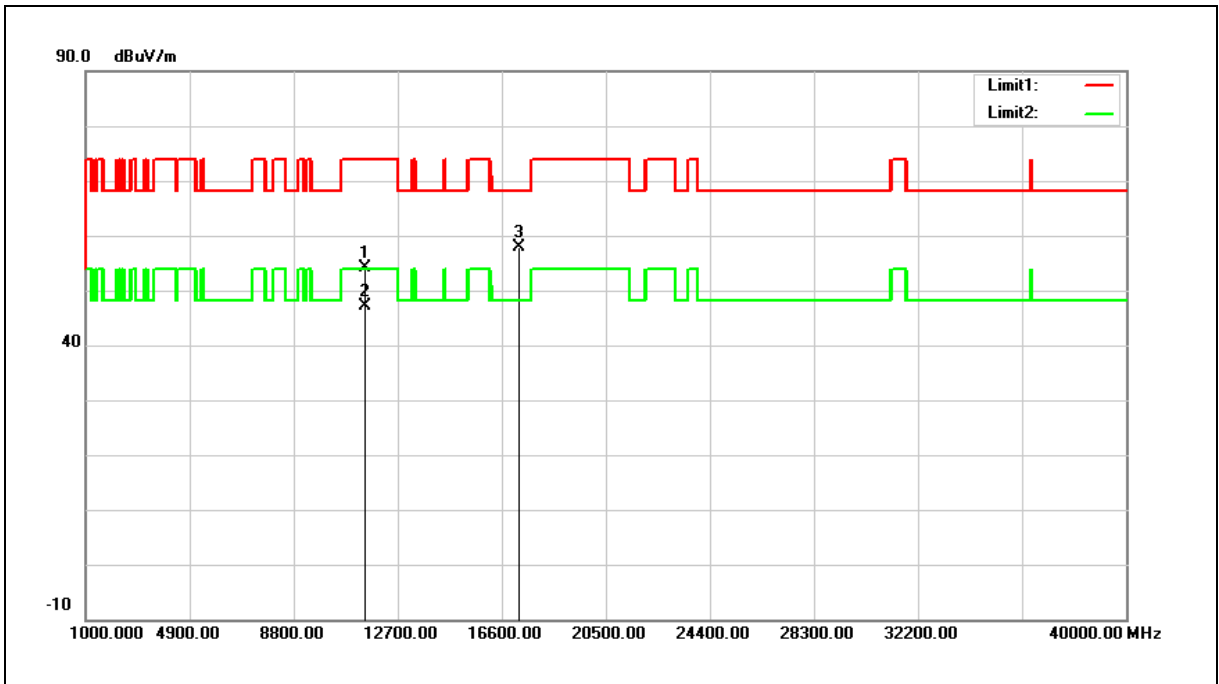

No.	Frequency (MHz)	Reading (dBuV)	Correct Factor (dB/m)	Result (dBuV/m)	Limit (dBuV/m)	Margin (dB)	Remark
1	11490.000	35.98	18.19	54.17	74.00	-19.83	peak
2	11490.000	28.89	18.19	47.08	54.00	-6.92	AVG
3	17235.000	34.41	23.43	57.84	68.20	-10.36	peak

Note:1.Result (dBuV/m) = Correct Factor (dB/m) + Reading(dBuV).

2.Correction factor (dB/m) = Antenna Factor (dB/m) + Cable loss (dB) – Pre-Amplifier gain (dB).

3.When the peak results are less than average limit, so not need to evaluate the average.

Standard:	FCC Part 15.407	Test Distance:	3 m
Test item:	Harmonic		
Frequency:	5785 MHz		
Mode:	Mode 1		
Ant.Polar.:	Horizontal		

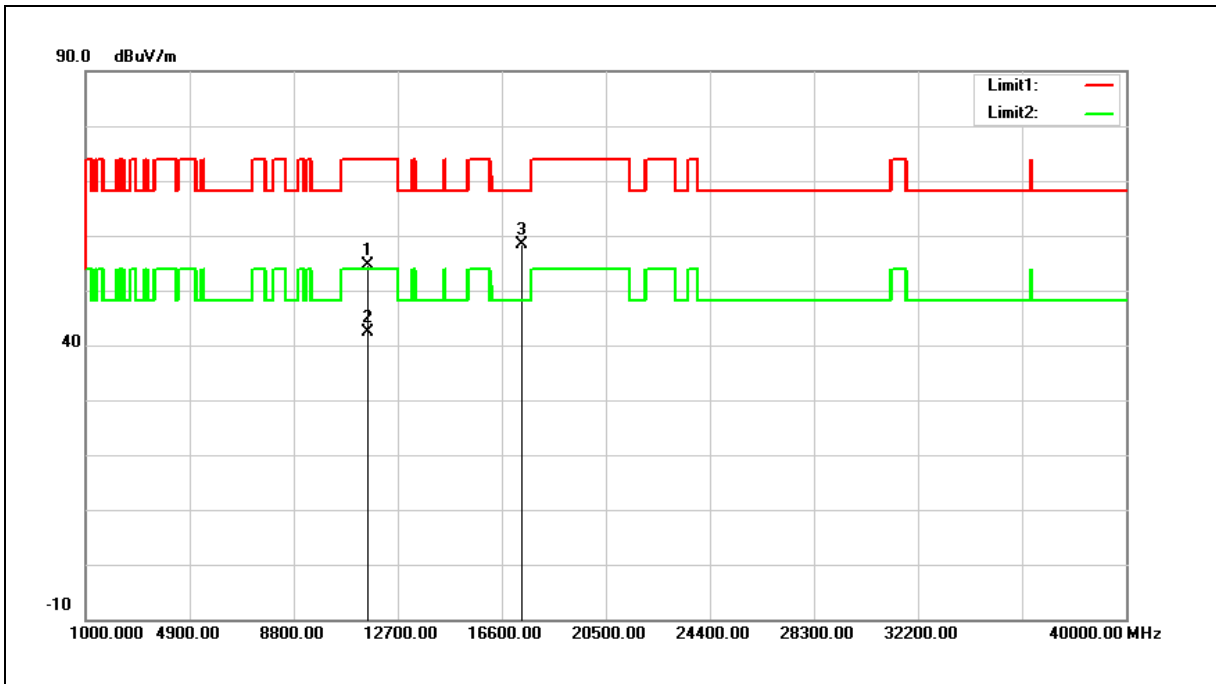

No.	Frequency (MHz)	Reading (dBuV)	Correct Factor (dB/m)	Result (dBuV/m)	Limit (dBuV/m)	Margin (dB)	Remark
1	11570.000	36.65	18.07	54.72	74.00	-19.28	peak
2	11570.000	24.27	18.07	42.34	54.00	-11.66	AVG
3	17355.000	34.44	24.04	58.48	68.20	-9.72	peak

Note:1.Result (dBuV/m) = Correct Factor (dB/m) + Reading(dBuV).

2.Correction factor (dB/m) = Antenna Factor (dB/m) + Cable loss (dB) – Pre-Amplifier gain (dB).

3.When the peak results are less than average limit, so not need to evaluate the average.

Standard:	FCC Part 15.407	Test Distance:	3 m
Test item:	Harmonic		
Frequency:	5785 MHz		
Mode:	Mode 1		
Ant.Polar.:	Vertical		

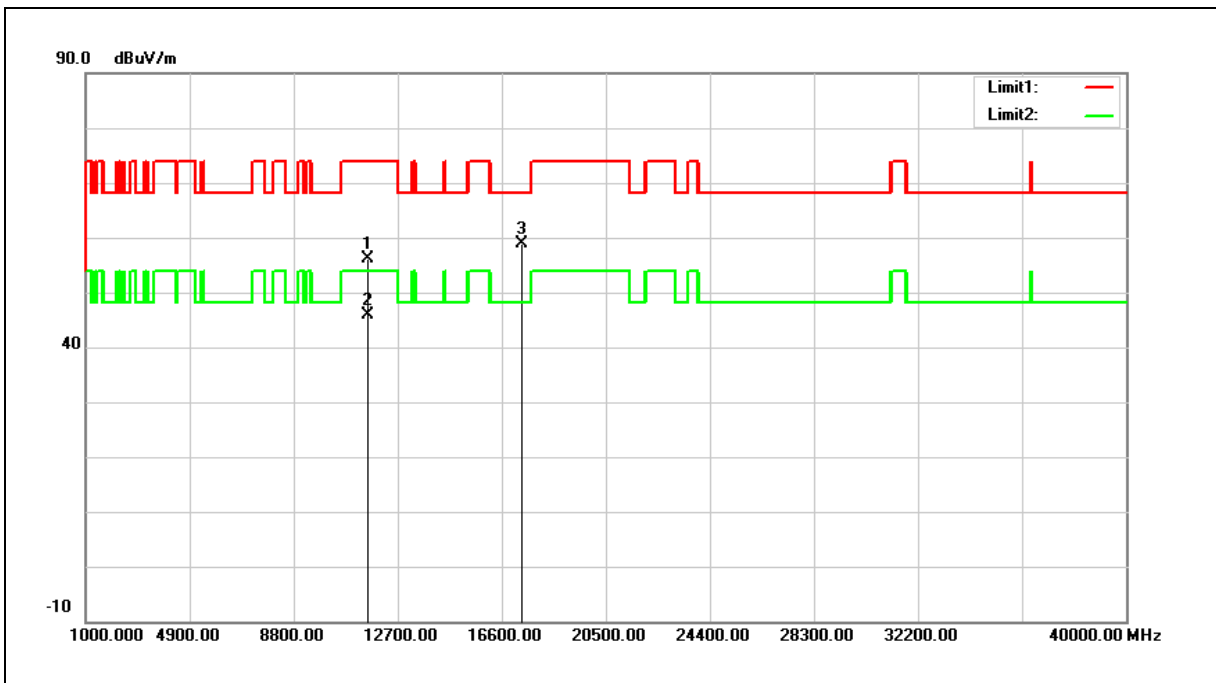

No.	Frequency (MHz)	Reading (dBuV)	Correct Factor (dB/m)	Result (dBuV/m)	Limit (dBuV/m)	Margin (dB)	Remark
1	11570.000	38.16	18.07	56.23	74.00	-17.77	peak
2	11570.000	27.84	18.07	45.91	54.00	-8.09	AVG
3	17355.000	34.95	24.04	58.99	68.20	-9.21	peak

Note:1.Result (dBuV/m) = Correct Factor (dB/m) + Reading(dBuV).

2.Correction factor (dB/m) = Antenna Factor (dB/m) + Cable loss (dB) – Pre-Amplifier gain (dB).

3.When the peak results are less than average limit, so not need to evaluate the average.

Standard:	FCC Part 15.407	Test Distance:	3 m
Test item:	Harmonic		
Frequency:	5825 MHz		
Mode:	Mode 1		
Ant.Polar.:	Horizontal		

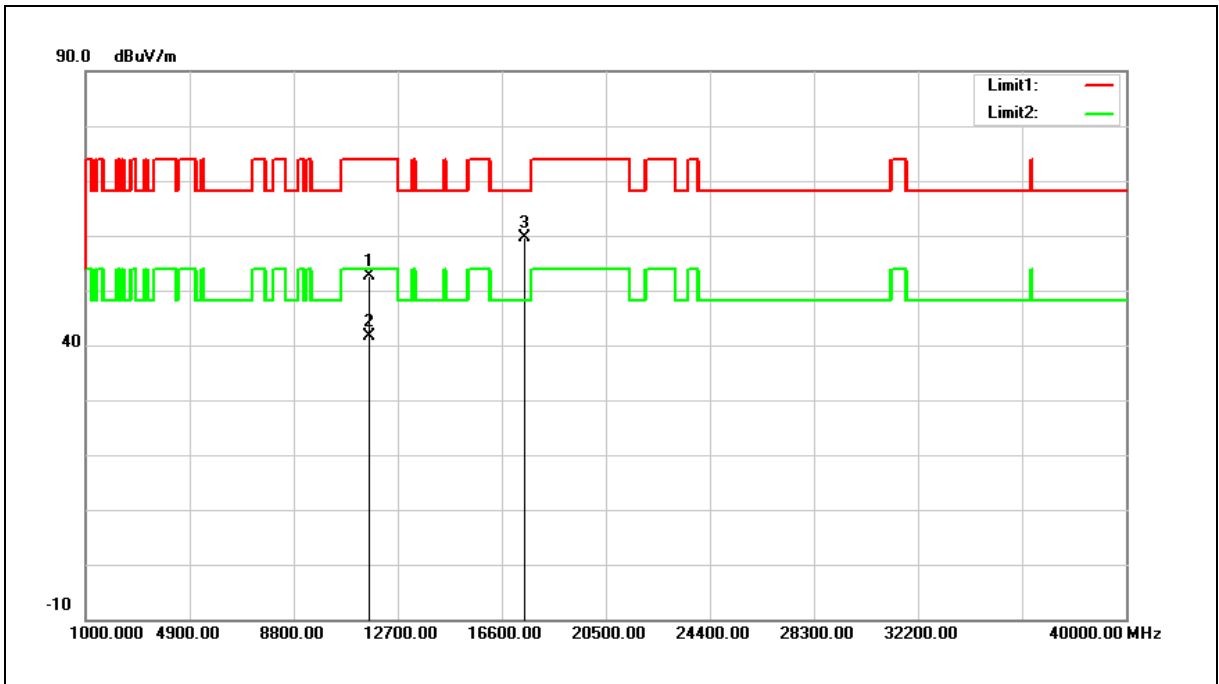

No.	Frequency (MHz)	Reading (dBuV)	Correct Factor (dB/m)	Result (dBuV/m)	Limit (dBuV/m)	Margin (dB)	Remark
1	11650.000	34.76	17.92	52.68	74.00	-21.32	peak
2	11650.000	23.79	17.92	41.71	54.00	-12.29	AVG
3	17475.000	34.97	24.64	59.61	68.20	-8.59	peak

Note:1.Result (dBuV/m) = Correct Factor (dB/m) + Reading(dBuV).

2.Correction factor (dB/m) = Antenna Factor (dB/m) + Cable loss (dB) – Pre-Amplifier gain (dB).

3.When the peak results are less than average limit, so not need to evaluate the average.

Standard:	FCC Part 15.407	Test Distance:	3 m
Test item:	Harmonic		
Frequency:	5825 MHz		
Mode:	Mode 1		
Ant.Polar.:	Vertical		

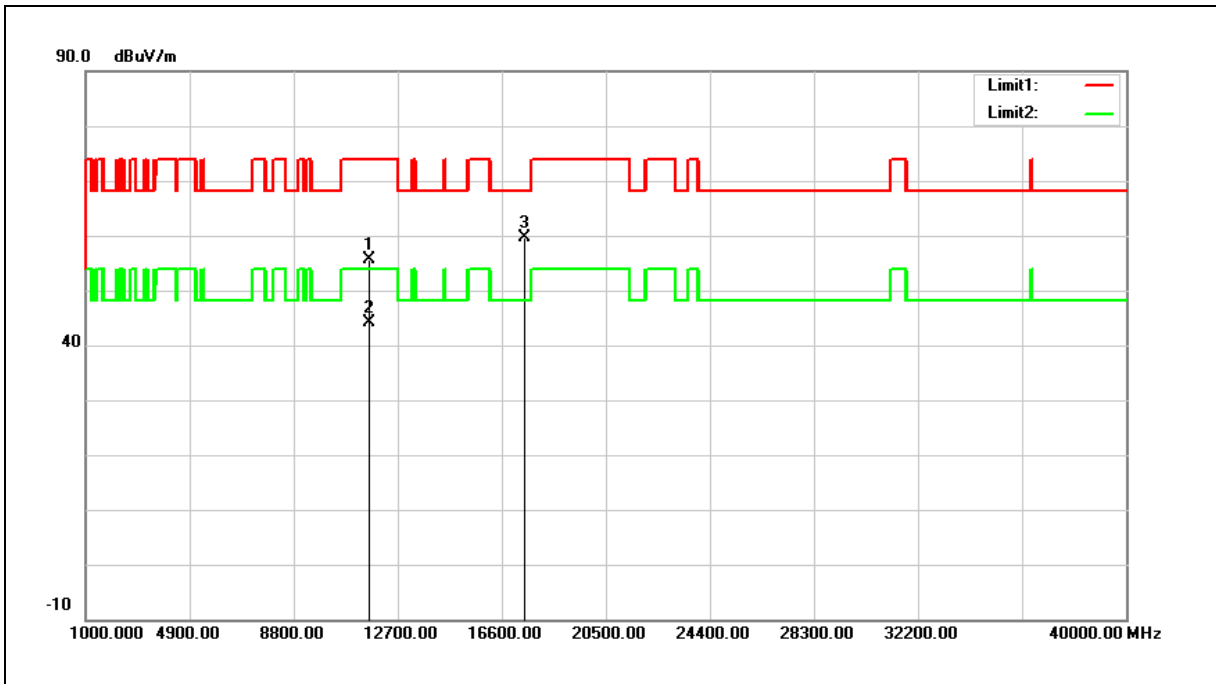

No.	Frequency (MHz)	Reading (dBuV)	Correct Factor (dB/m)	Result (dBuV/m)	Limit (dBuV/m)	Margin (dB)	Remark
1	11650.000	37.67	17.92	55.59	74.00	-18.41	peak
2	11650.000	26.16	17.92	44.08	54.00	-9.92	AVG
3	17475.000	35.10	24.64	59.74	68.20	-8.46	peak

Note:1.Result (dBuV/m) = Correct Factor (dB/m) + Reading(dBuV).

2.Correction factor (dB/m) = Antenna Factor (dB/m) + Cable loss (dB) – Pre-Amplifier gain (dB).

3.When the peak results are less than average limit, so not need to evaluate the average.

Standard:	FCC Part 15.407	Test Distance:	3 m
Test item:	Harmonic		
Frequency:	5180 MHz		
Mode:	Mode 2		
Ant.Polar.:	Horizontal		

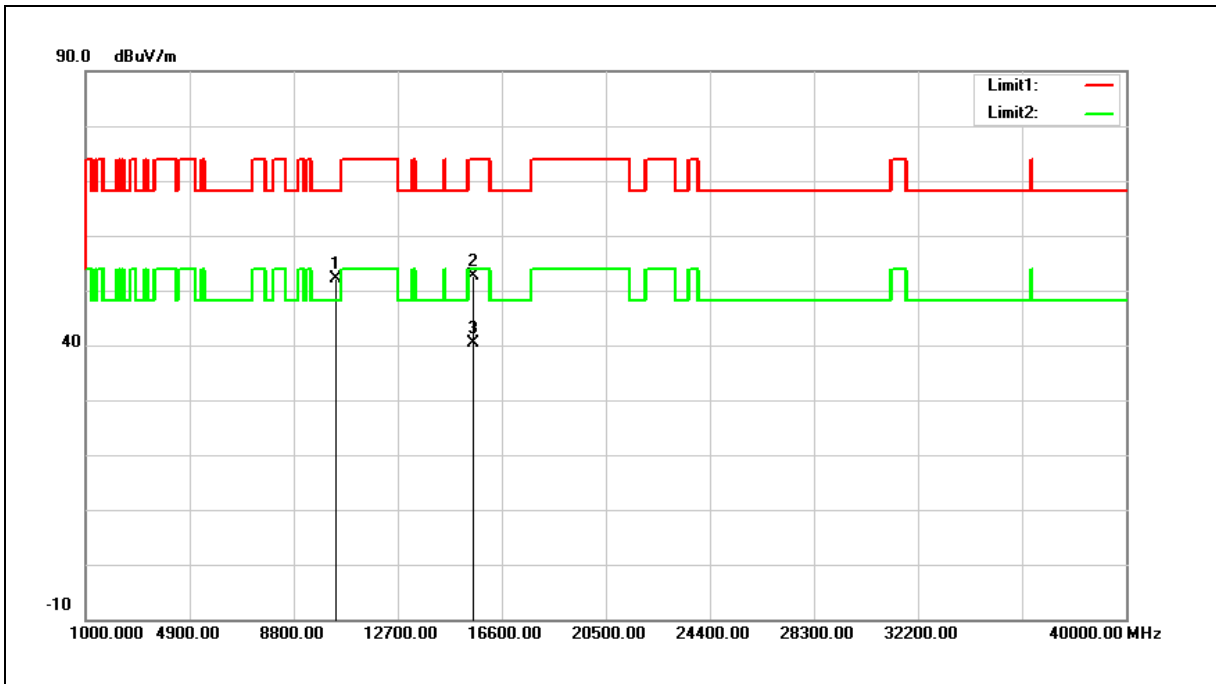

No.	Frequency (MHz)	Reading (dBuV)	Correct Factor (dB/m)	Result (dBuV/m)	Limit (dBuV/m)	Margin (dB)	Remark
1	10360.000	35.94	16.07	52.01	68.20	-16.19	peak
2	15540.000	34.59	18.03	52.62	74.00	-21.38	peak
3	15540.000	22.38	18.03	40.41	54.00	-13.59	AVG

Note:1.Result (dBuV/m) = Correct Factor (dB/m) + Reading(dBuV).

2.Correction factor (dB/m) = Antenna Factor (dB/m) + Cable loss (dB) – Pre-Amplifier gain (dB).

3.When the peak results are less than average limit, so not need to evaluate the average.

Standard:	FCC Part 15.407	Test Distance:	3 m
Test item:	Harmonic		
Frequency:	5180 MHz		
Mode:	Mode 2		
Ant.Polar.:	Vertical		

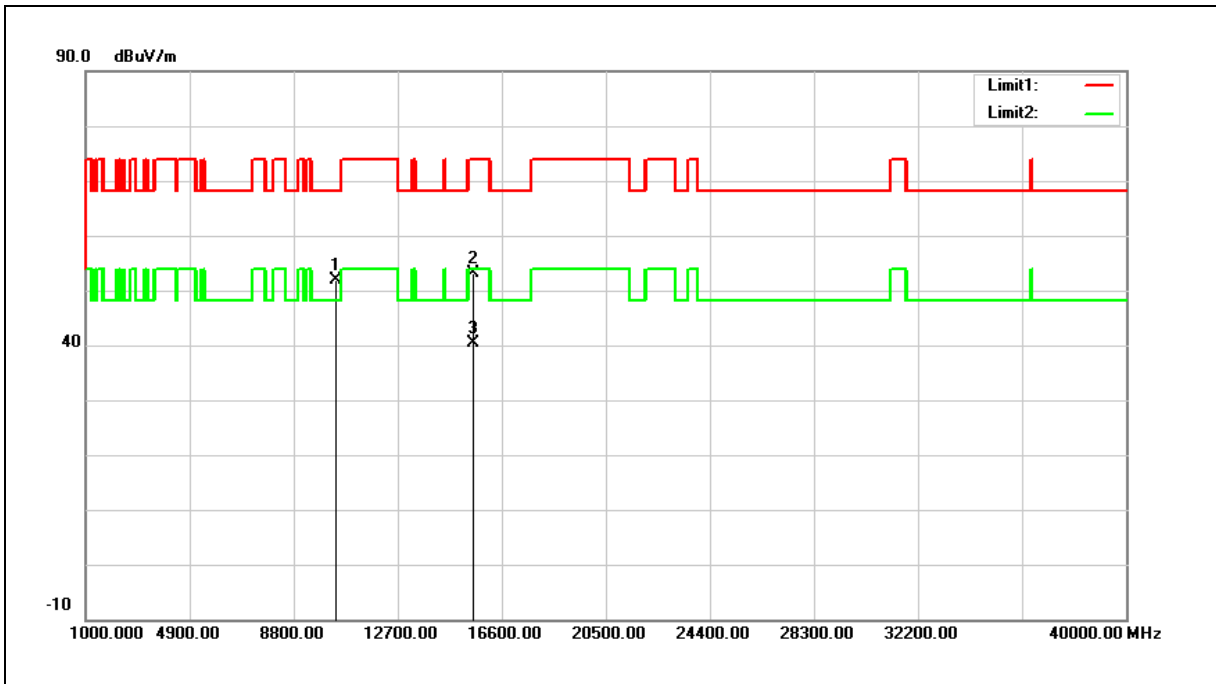

No.	Frequency (MHz)	Reading (dBuV)	Correct Factor (dB/m)	Result (dBuV/m)	Limit (dBuV/m)	Margin (dB)	Remark
1	10360.000	35.77	16.07	51.84	68.20	-16.36	peak
2	15540.000	35.00	18.03	53.03	74.00	-20.97	peak
3	15540.000	22.33	18.03	40.36	54.00	-13.64	AVG

Note:1.Result (dBuV/m) = Correct Factor (dB/m) + Reading(dBuV).

2.Correction factor (dB/m) = Antenna Factor (dB/m) + Cable loss (dB) – Pre-Amplifier gain (dB).

3.When the peak results are less than average limit, so not need to evaluate the average.

Standard:	FCC Part 15.407	Test Distance:	3 m
Test item:	Harmonic		
Frequency:	5200 MHz		
Mode:	Mode 2		
Ant.Polar.:	Horizontal		

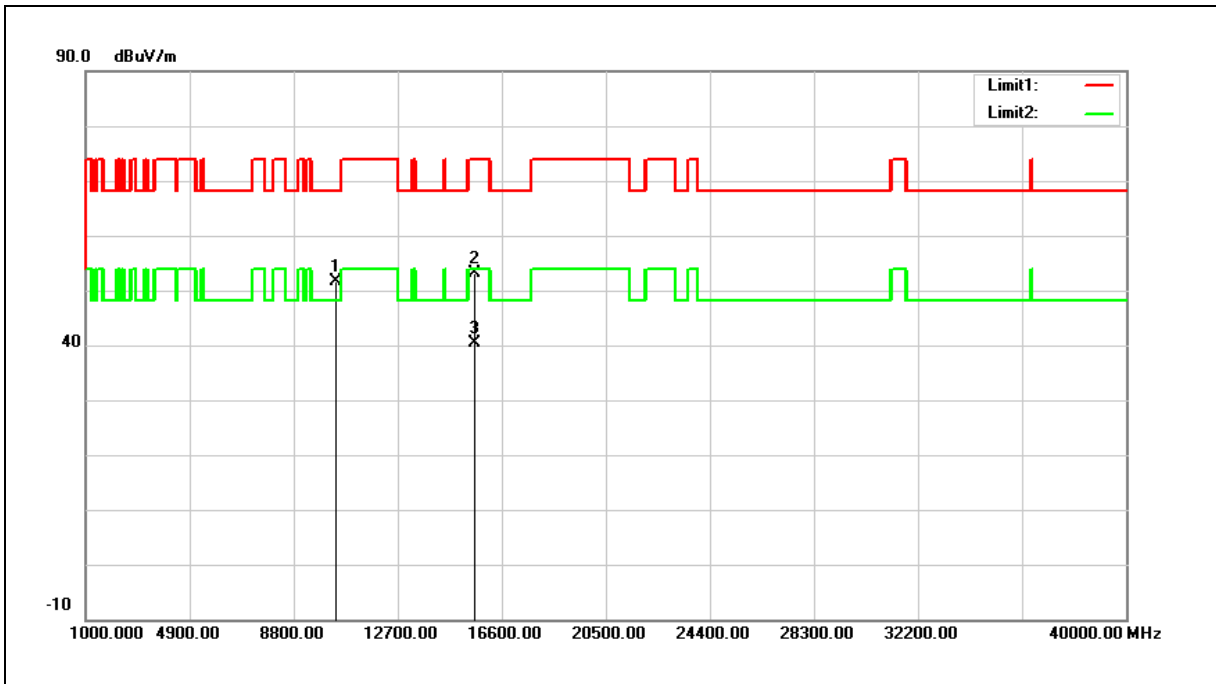

No.	Frequency (MHz)	Reading (dBuV)	Correct Factor (dB/m)	Result (dBuV/m)	Limit (dBuV/m)	Margin (dB)	Remark
1	10400.000	35.49	16.18	51.67	68.20	-16.53	peak
2	15600.000	35.33	17.76	53.09	74.00	-20.91	peak
3	15600.000	22.74	17.76	40.50	54.00	-13.50	AVG

Note:1.Result (dBuV/m) = Correct Factor (dB/m) + Reading(dBuV).

2.Correction factor (dB/m) = Antenna Factor (dB/m) + Cable loss (dB) – Pre-Amplifier gain (dB).

3.When the peak results are less than average limit, so not need to evaluate the average.

Standard:	FCC Part 15.407	Test Distance:	3 m
Test item:	Harmonic		
Frequency:	5200 MHz		
Mode:	Mode 2		
Ant.Polar.:	Vertical		

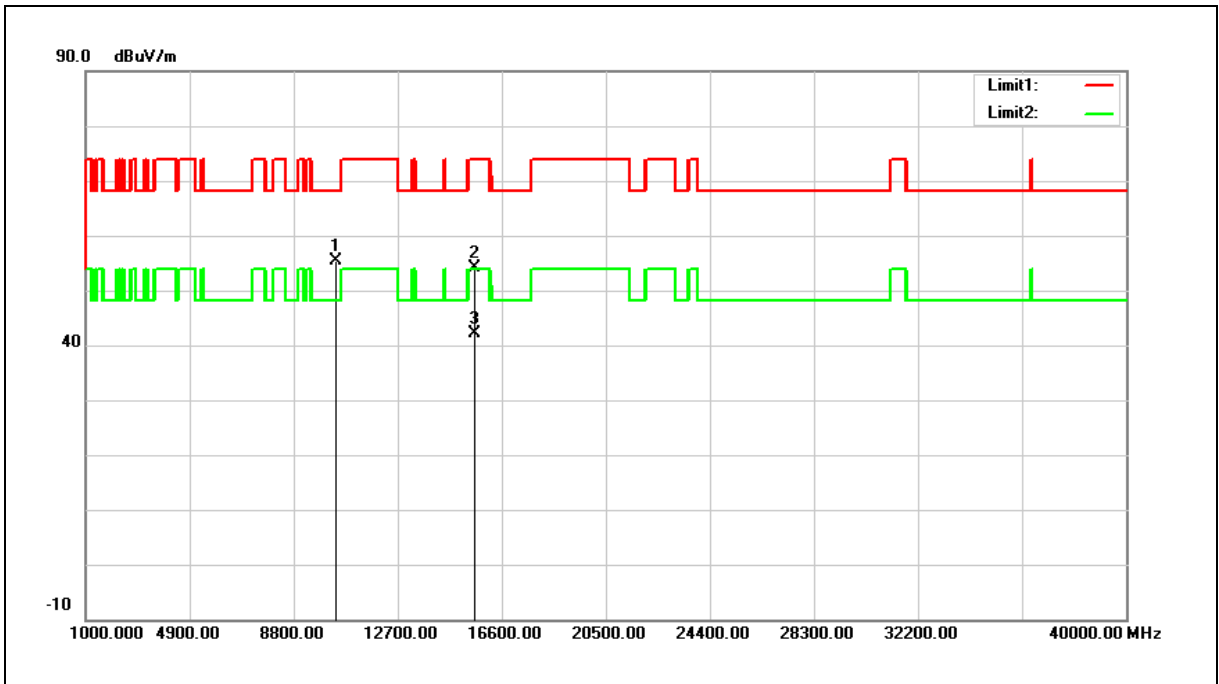

No.	Frequency (MHz)	Reading (dBuV)	Correct Factor (dB/m)	Result (dBuV/m)	Limit (dBuV/m)	Margin (dB)	Remark
1	10400.000	39.17	16.18	55.35	68.20	-12.85	peak
2	15600.000	36.39	17.76	54.15	74.00	-19.85	peak
3	15600.000	24.45	17.76	42.21	54.00	-11.79	AVG

Note:1.Result (dBuV/m) = Correct Factor (dB/m) + Reading(dBuV).

2.Correction factor (dB/m) = Antenna Factor (dB/m) + Cable loss (dB) – Pre-Amplifier gain (dB).

3.When the peak results are less than average limit, so not need to evaluate the average.

Standard:	FCC Part 15.407	Test Distance:	3 m
Test item:	Harmonic		
Frequency:	5240 MHz		
Mode:	Mode 2		
Ant.Polar.:	Horizontal		

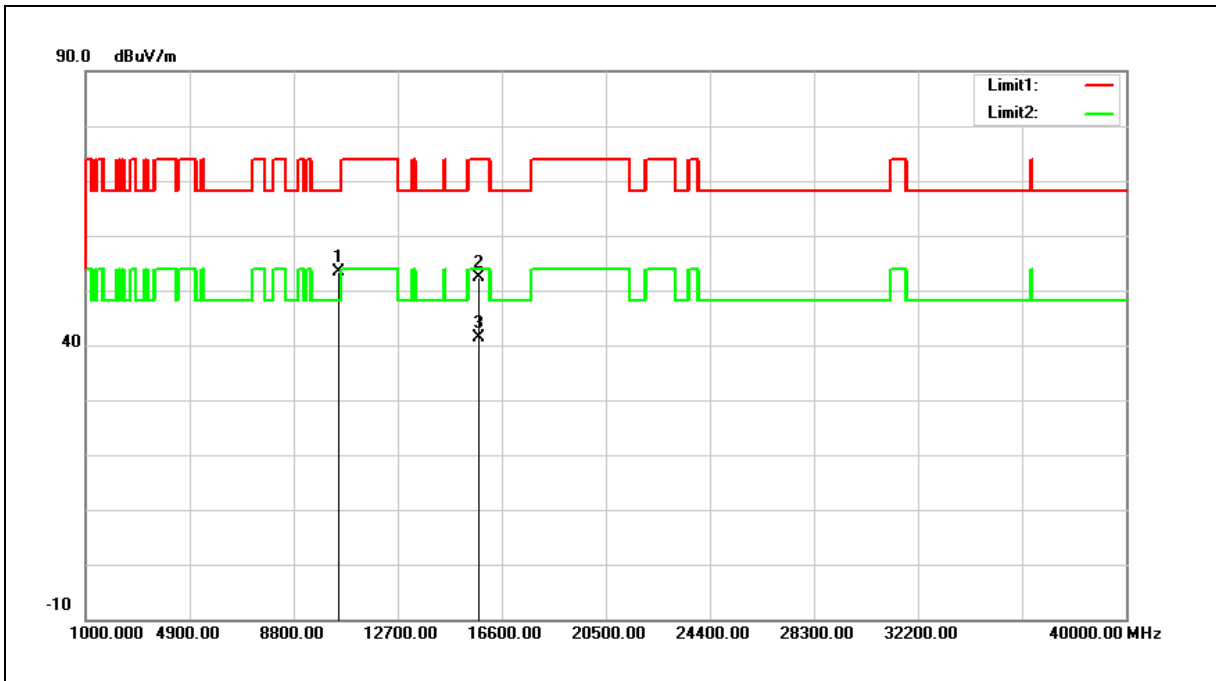

No.	Frequency (MHz)	Reading (dBuV)	Correct Factor (dB/m)	Result (dBuV/m)	Limit (dBuV/m)	Margin (dB)	Remark
1	10480.000	36.93	16.38	53.31	68.20	-14.89	peak
2	15720.000	35.20	17.22	52.42	74.00	-21.58	peak
3	15720.000	24.11	17.22	41.33	54.00	-12.67	AVG

Note:1.Result (dBuV/m) = Correct Factor (dB/m) + Reading(dBuV).

2.Correction factor (dB/m) = Antenna Factor (dB/m) + Cable loss (dB) – Pre-Amplifier gain (dB).

3.When the peak results are less than average limit, so not need to evaluate the average.

Standard:	FCC Part 15.407	Test Distance:	3 m
Test item:	Harmonic		
Frequency:	5240 MHz		
Mode:	Mode 2		
Ant.Polar.:	Vertical		

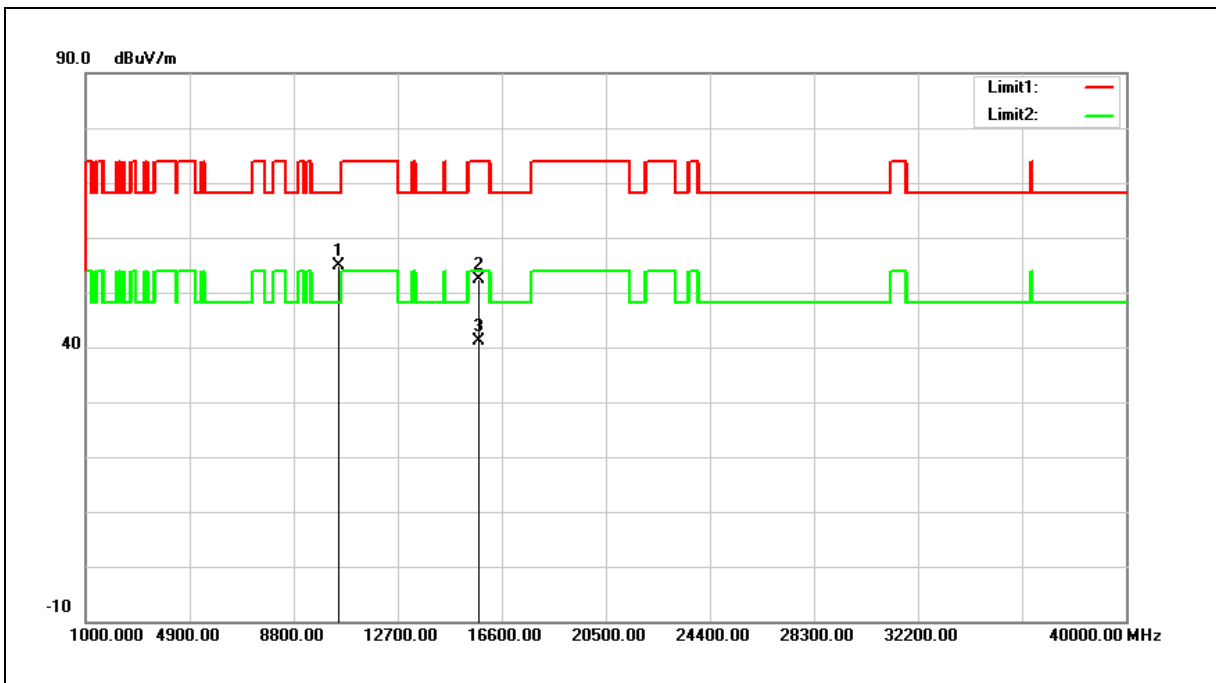

No.	Frequency (MHz)	Reading (dBuV)	Correct Factor (dB/m)	Result (dBuV/m)	Limit (dBuV/m)	Margin (dB)	Remark
1	10480.000	38.42	16.38	54.80	68.20	-13.40	peak
2	15720.000	35.28	17.22	52.50	74.00	-21.50	peak
3	15720.000	23.97	17.22	41.19	54.00	-12.81	AVG

Note:1.Result (dBuV/m) = Correct Factor (dB/m) + Reading(dBuV).

2.Correction factor (dB/m) = Antenna Factor (dB/m) + Cable loss (dB) – Pre-Amplifier gain (dB).

3.When the peak results are less than average limit, so not need to evaluate the average.

Standard:	FCC Part 15.407	Test Distance:	3 m
Test item:	Harmonic		
Frequency:	5745 MHz		
Mode:	Mode 2		
Ant.Polar.:	Horizontal		

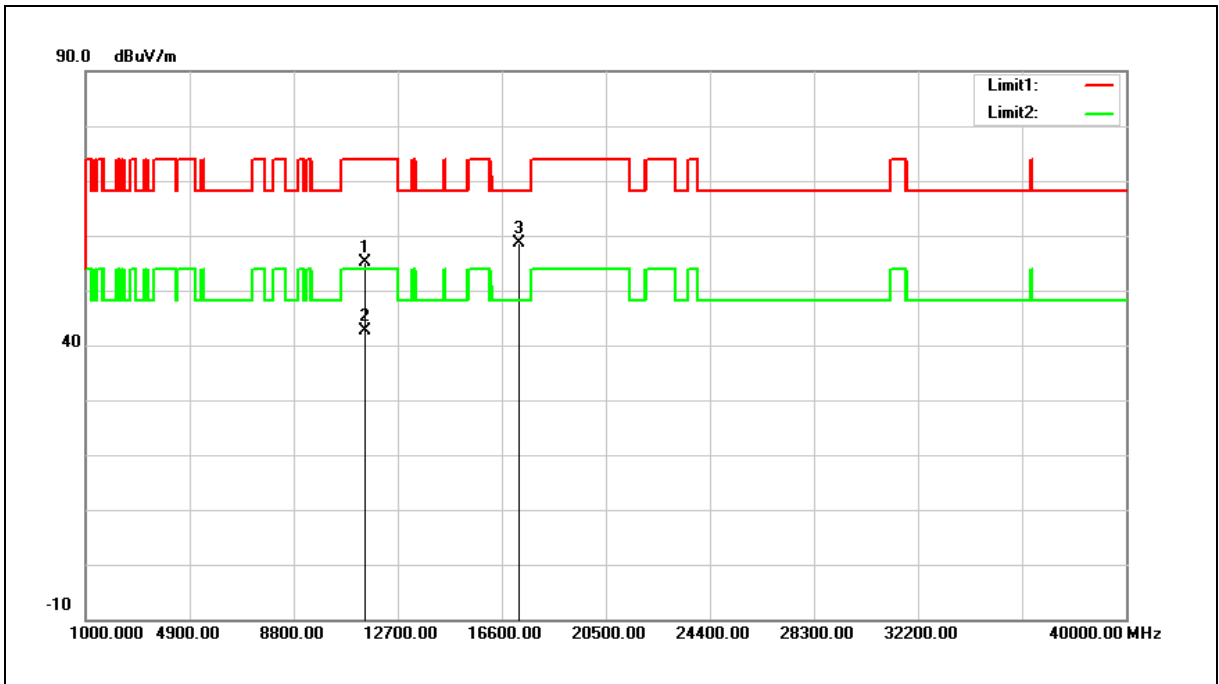

No.	Frequency (MHz)	Reading (dBuV)	Correct Factor (dB/m)	Result (dBuV/m)	Limit (dBuV/m)	Margin (dB)	Remark
1	11490.000	36.92	18.19	55.11	74.00	-18.89	peak
2	11490.000	24.36	18.19	42.55	54.00	-11.45	AVG
3	17235.000	35.23	23.43	58.66	68.20	-9.54	peak

Note:1.Result (dBuV/m) = Correct Factor (dB/m) + Reading(dBuV).

2.Correction factor (dB/m) = Antenna Factor (dB/m) + Cable loss (dB) – Pre-Amplifier gain (dB).

3.When the peak results are less than average limit, so not need to evaluate the average.

Standard:	FCC Part 15.407	Test Distance:	3 m
Test item:	Harmonic		
Frequency:	5745 MHz		
Mode:	Mode 2		
Ant.Polar.:	Vertical		

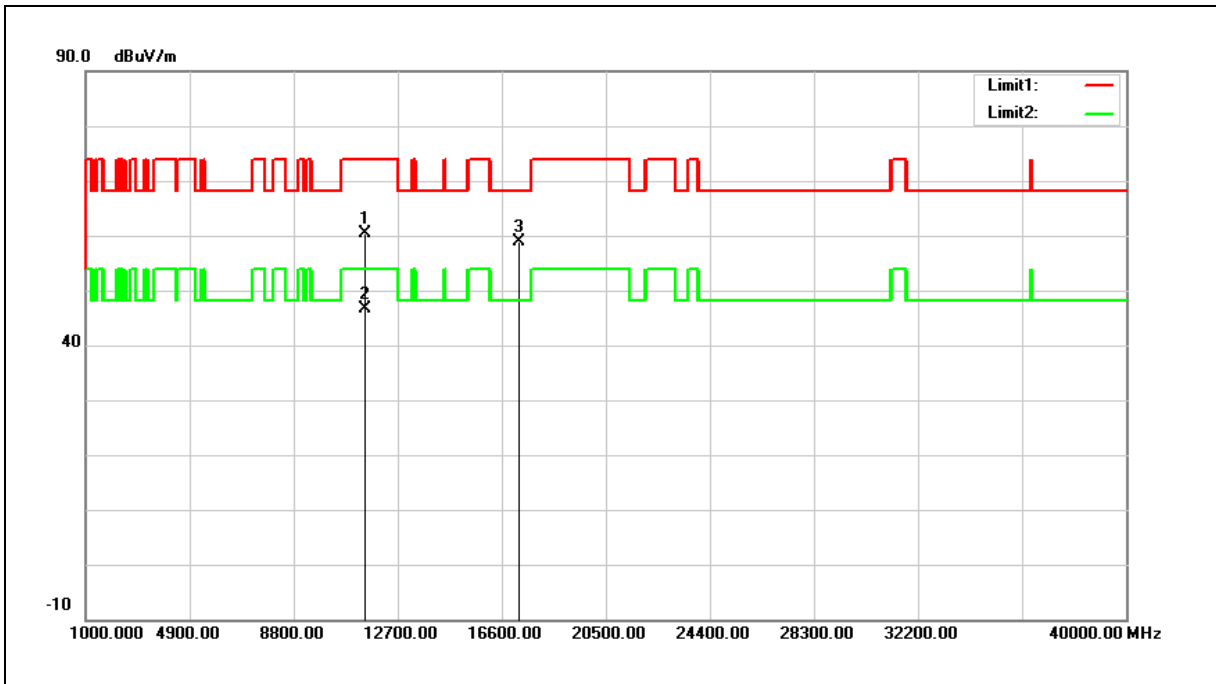

No.	Frequency (MHz)	Reading (dBuV)	Correct Factor (dB/m)	Result (dBuV/m)	Limit (dBuV/m)	Margin (dB)	Remark
1	11490.000	42.25	18.19	60.44	74.00	-13.56	peak
2	11490.000	28.43	18.19	46.62	54.00	-7.38	AVG
3	17235.000	35.36	23.43	58.79	68.20	-9.41	peak

Note:1.Result (dBuV/m) = Correct Factor (dB/m) + Reading(dBuV).

2.Correction factor (dB/m) = Antenna Factor (dB/m) + Cable loss (dB) – Pre-Amplifier gain (dB).

3.When the peak results are less than average limit, so not need to evaluate the average.

Standard:	FCC Part 15.407	Test Distance:	3 m
Test item:	Harmonic		
Frequency:	5785 MHz		
Mode:	Mode 2		
Ant.Polar.:	Horizontal		

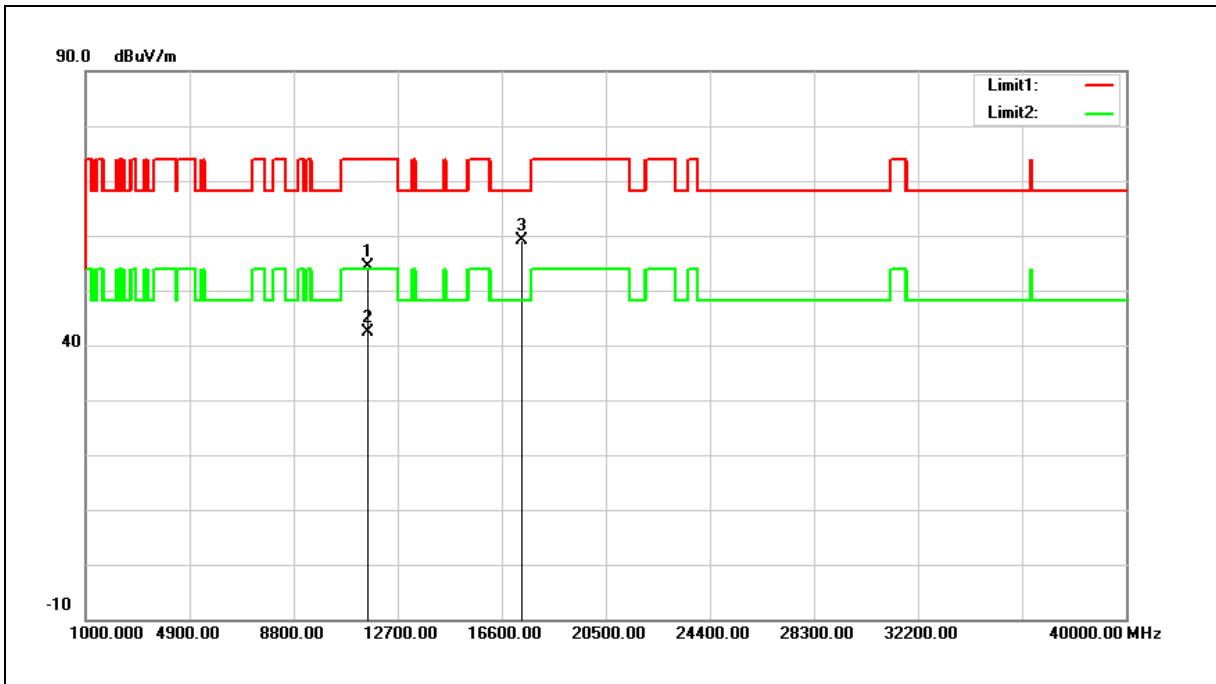

No.	Frequency (MHz)	Reading (dBuV)	Correct Factor (dB/m)	Result (dBuV/m)	Limit (dBuV/m)	Margin (dB)	Remark
1	11570.000	36.20	18.07	54.27	74.00	-19.73	peak
2	11570.000	24.27	18.07	42.34	54.00	-11.66	AVG
3	17355.000	35.01	24.04	59.05	68.20	-9.15	peak

Note:1.Result (dBuV/m) = Correct Factor (dB/m) + Reading(dBuV).

2.Correction factor (dB/m) = Antenna Factor (dB/m) + Cable loss (dB) – Pre-Amplifier gain (dB).

3.When the peak results are less than average limit, so not need to evaluate the average.

Standard:	FCC Part 15.407	Test Distance:	3 m
Test item:	Harmonic		
Frequency:	5785 MHz		
Mode:	Mode 2		
Ant.Polar.:	Vertical		

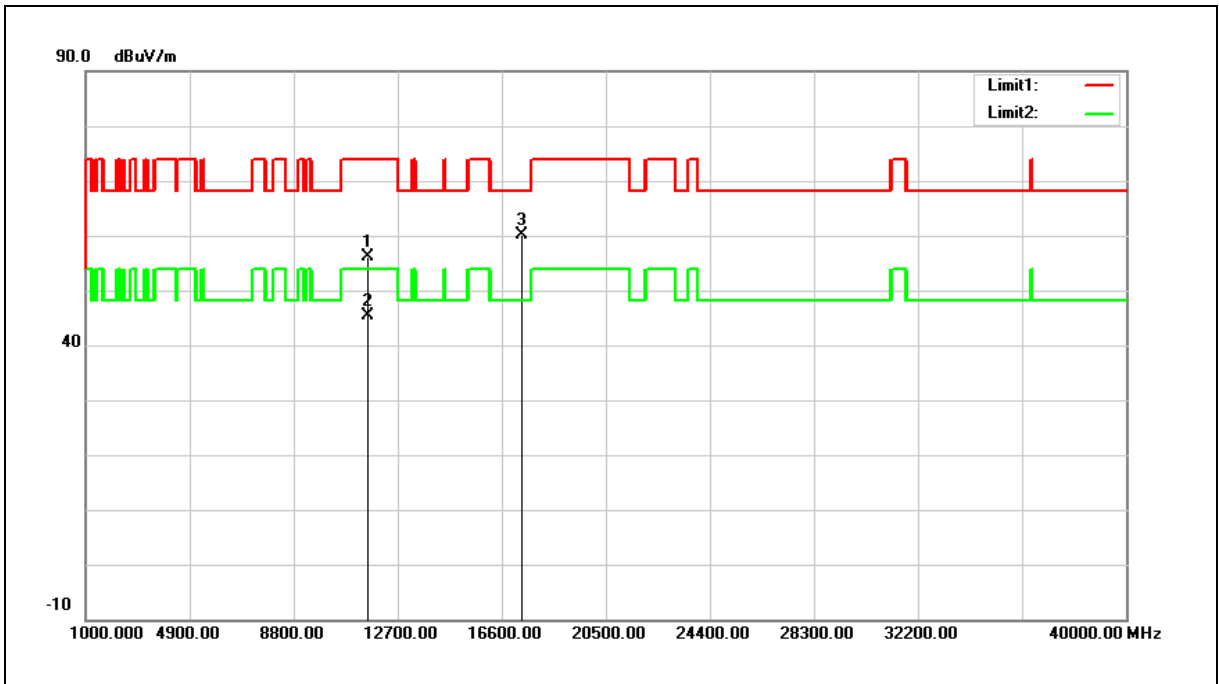

No.	Frequency (MHz)	Reading (dBuV)	Correct Factor (dB/m)	Result (dBuV/m)	Limit (dBuV/m)	Margin (dB)	Remark
1	11570.000	38.06	18.07	56.13	74.00	-17.87	peak
2	11570.000	27.34	18.07	45.41	54.00	-8.59	AVG
3	17355.000	36.11	24.04	60.15	68.20	-8.05	peak

Note:1.Result (dBuV/m) = Correct Factor (dB/m) + Reading(dBuV).

2.Correction factor (dB/m) = Antenna Factor (dB/m) + Cable loss (dB) – Pre-Amplifier gain (dB).

3.When the peak results are less than average limit, so not need to evaluate the average.

Standard:	FCC Part 15.407	Test Distance:	3 m
Test item:	Harmonic		
Frequency:	5825 MHz		
Mode:	Mode 2		
Ant.Polar.:	Horizontal		

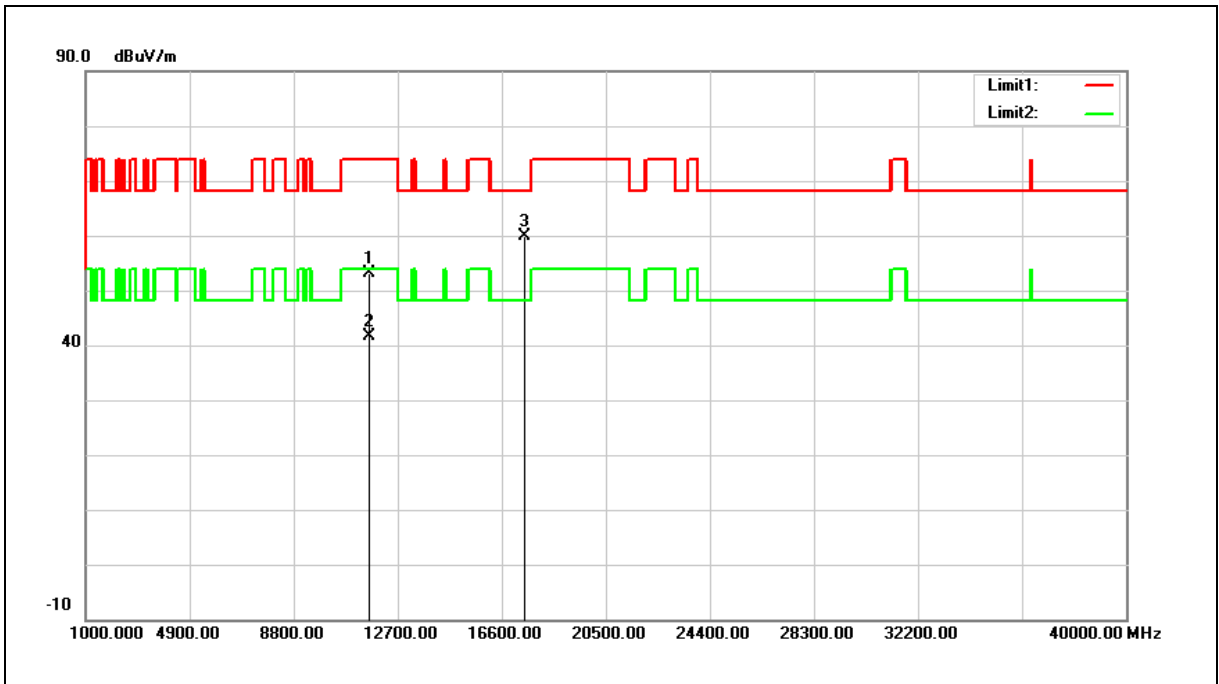

No.	Frequency (MHz)	Reading (dBuV)	Correct Factor (dB/m)	Result (dBuV/m)	Limit (dBuV/m)	Margin (dB)	Remark
1	11650.000	35.24	17.92	53.16	74.00	-20.84	peak
2	11650.000	23.59	17.92	41.51	54.00	-12.49	AVG
3	17475.000	35.16	24.64	59.80	68.20	-8.40	peak

Note:1.Result (dBuV/m) = Correct Factor (dB/m) + Reading(dBuV).

2.Correction factor (dB/m) = Antenna Factor (dB/m) + Cable loss (dB) – Pre-Amplifier gain (dB).

3.When the peak results are less than average limit, so not need to evaluate the average.

Standard:	FCC Part 15.407	Test Distance:	3 m
Test item:	Harmonic		
Frequency:	5825 MHz		
Mode:	Mode 2		
Ant.Polar.:	Vertical		

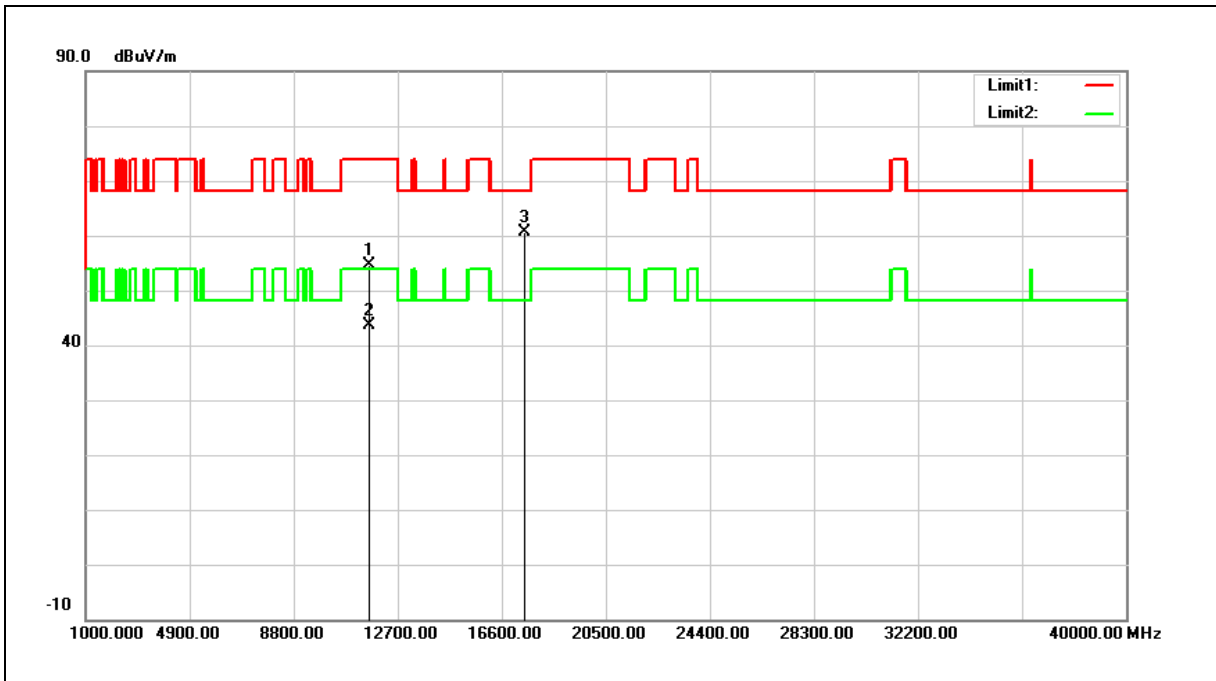

No.	Frequency (MHz)	Reading (dBuV)	Correct Factor (dB/m)	Result (dBuV/m)	Limit (dBuV/m)	Margin (dB)	Remark
1	11650.000	36.64	17.92	54.56	74.00	-19.44	peak
2	11650.000	25.67	17.92	43.59	54.00	-10.41	AVG
3	17475.000	36.00	24.64	60.64	68.20	-7.56	peak

Note:1.Result (dBuV/m) = Correct Factor (dB/m) + Reading(dBuV).

2.Correction factor (dB/m) = Antenna Factor (dB/m) + Cable loss (dB) – Pre-Amplifier gain (dB).

3.When the peak results are less than average limit, so not need to evaluate the average.

Band Edge

Peak

Standard:	FCC Part 15.407	Test Distance:	3 m
Test item:	Band edge		
Frequency:	5180 MHz		
Mode:	Mode 1		
Ant.Polar.:	Horizontal		

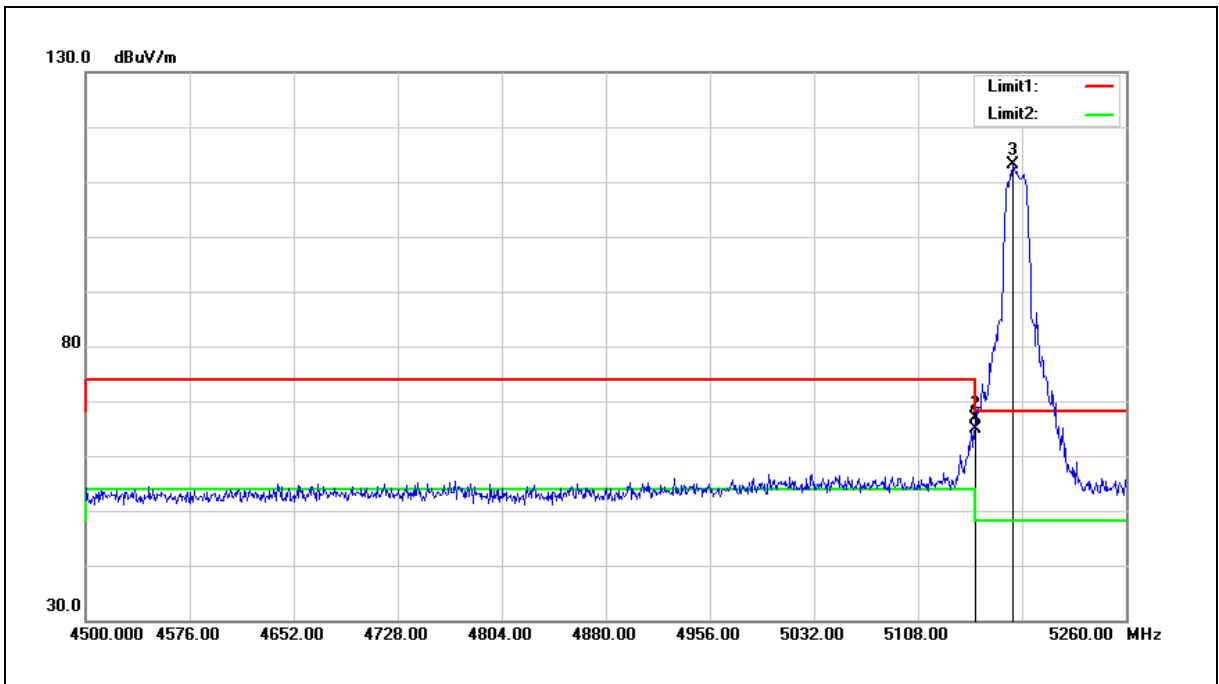

No.	Frequency (MHz)	Reading (dBuV)	Correct Factor (dB/m)	Result (dBuV/m)	Limit (dBuV/m)	Margin (dB)	Remark
1	5149.800	60.16	4.80	64.96	74.00	-9.04	peak
2	5150.000	62.04	4.80	66.84	74.00	-7.16	peak
3	5177.160	108.19	4.85	113.04	68.20	44.84	peak

Note:1.Result (dBuV/m) = Correct Factor (dB/m) + Reading(dBuV).

2.Correction factor (dB/m) = Antenna Factor (dB/m) + Cable loss (dB) – Pre-Amplifier gain (dB).

3.When the peak results are less than average limit, so not need to evaluate the average.

Standard:	FCC Part 15.407	Test Distance:	3 m
Test item:	Band edge		
Frequency:	5180 MHz		
Mode:	Mode 1		
Ant.Polar.:	Vertical		

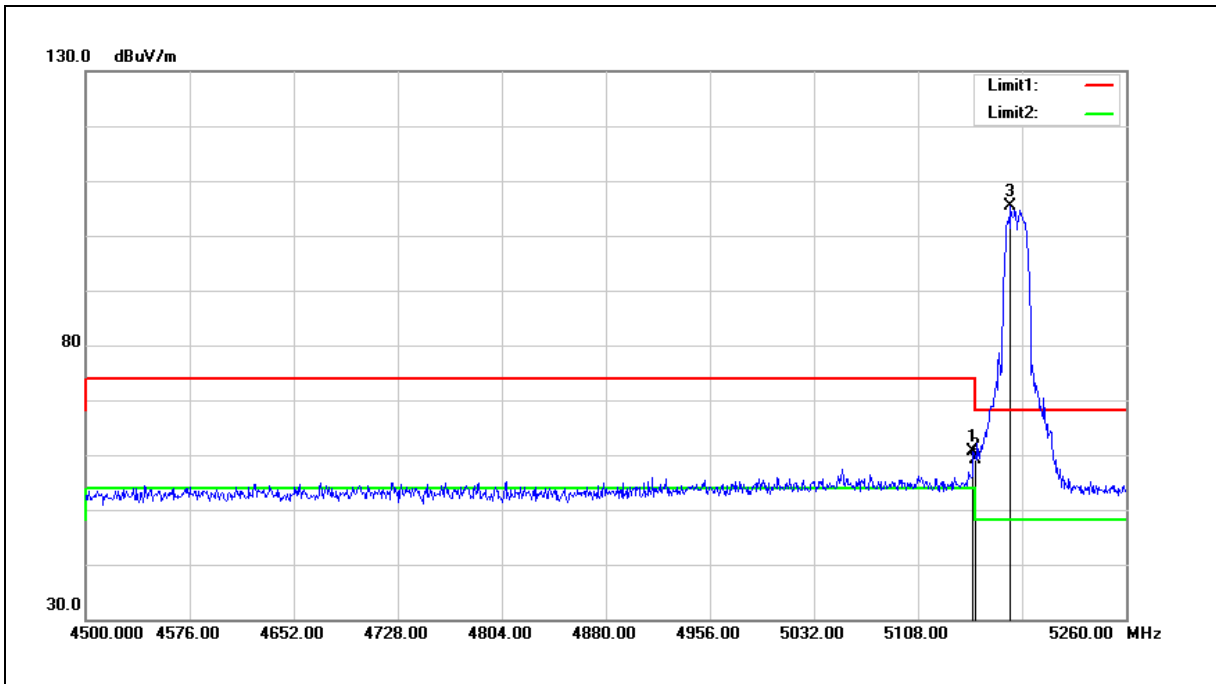

No.	Frequency (MHz)	Reading (dBuV)	Correct Factor (dB/m)	Result (dBuV/m)	Limit (dBuV/m)	Margin (dB)	Remark
1	5148.280	55.82	4.80	60.62	74.00	-13.38	peak
2	5150.000	54.21	4.80	59.01	74.00	-14.99	peak
3	5175.640	100.49	4.85	105.34	68.20	37.14	peak

Note:1.Result (dBuV/m) = Correct Factor (dB/m) + Reading(dBuV).

2.Correction factor (dB/m) = Antenna Factor (dB/m) + Cable loss (dB) – Pre-Amplifier gain (dB).

3.When the peak results are less than average limit, so not need to evaluate the average.

Standard:	FCC Part 15.407	Test Distance:	3 m
Test item:	Band edge		
Frequency:	5240 MHz		
Mode:	Mode 1		
Ant.Polar.:	Horizontal		

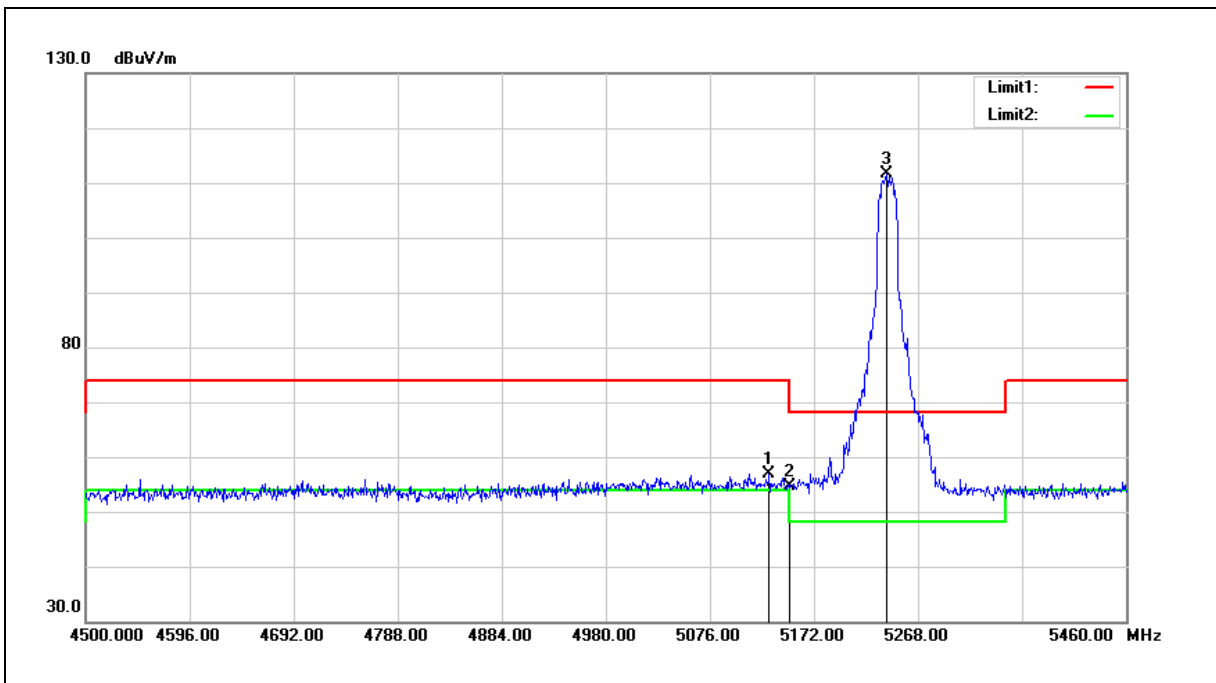

No.	Frequency (MHz)	Reading (dBuV)	Correct Factor (dB/m)	Result (dBuV/m)	Limit (dBuV/m)	Margin (dB)	Remark
1	5130.720	52.20	4.77	56.97	74.00	-17.03	peak
2	5150.000	49.74	4.80	54.54	74.00	-19.46	peak
3	5239.200	106.82	4.93	111.75	68.20	43.55	peak

Note:1.Result (dBuV/m) = Correct Factor (dB/m) + Reading(dBuV).

2.Correction factor (dB/m) = Antenna Factor (dB/m) + Cable loss (dB) – Pre-Amplifier gain (dB).

3.When the peak results are less than average limit, so not need to evaluate the average.

Standard:	FCC Part 15.407	Test Distance:	3 m
Test item:	Band edge		
Frequency:	5240 MHz		
Mode:	Mode 1		
Ant.Polar.:	Vertical		

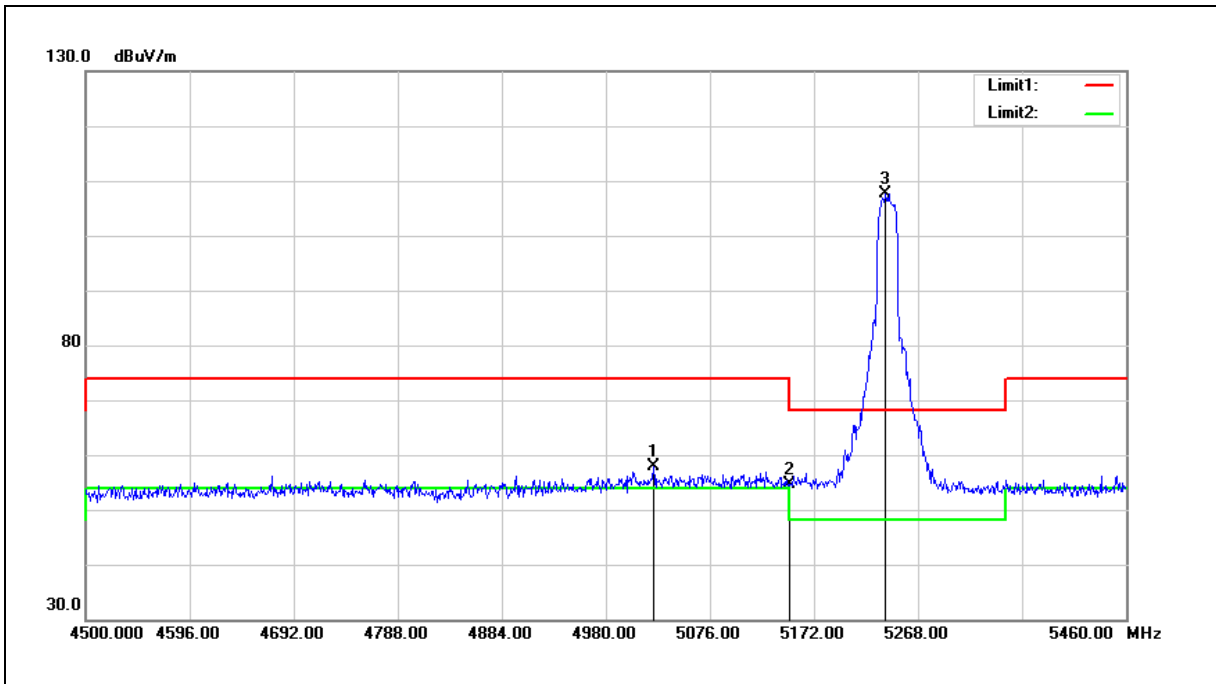

No.	Frequency (MHz)	Reading (dBuV)	Correct Factor (dB/m)	Result (dBuV/m)	Limit (dBuV/m)	Margin (dB)	Remark
1	5024.160	53.21	4.63	57.84	74.00	-16.16	peak
2	5150.000	49.93	4.80	54.73	74.00	-19.27	peak
3	5238.240	102.62	4.93	107.55	68.20	39.35	peak

Note:1.Result (dBuV/m) = Correct Factor (dB/m) + Reading(dBuV).

2.Correction factor (dB/m) = Antenna Factor (dB/m) + Cable loss (dB) – Pre-Amplifier gain (dB).

3.When the peak results are less than average limit, so not need to evaluate the average.

Standard:	FCC Part 15.407	Test Distance:	3 m
Test item:	Band edge		
Frequency:	5745 MHz		
Mode:	Mode 1		
Ant.Polar.:	Horizontal		

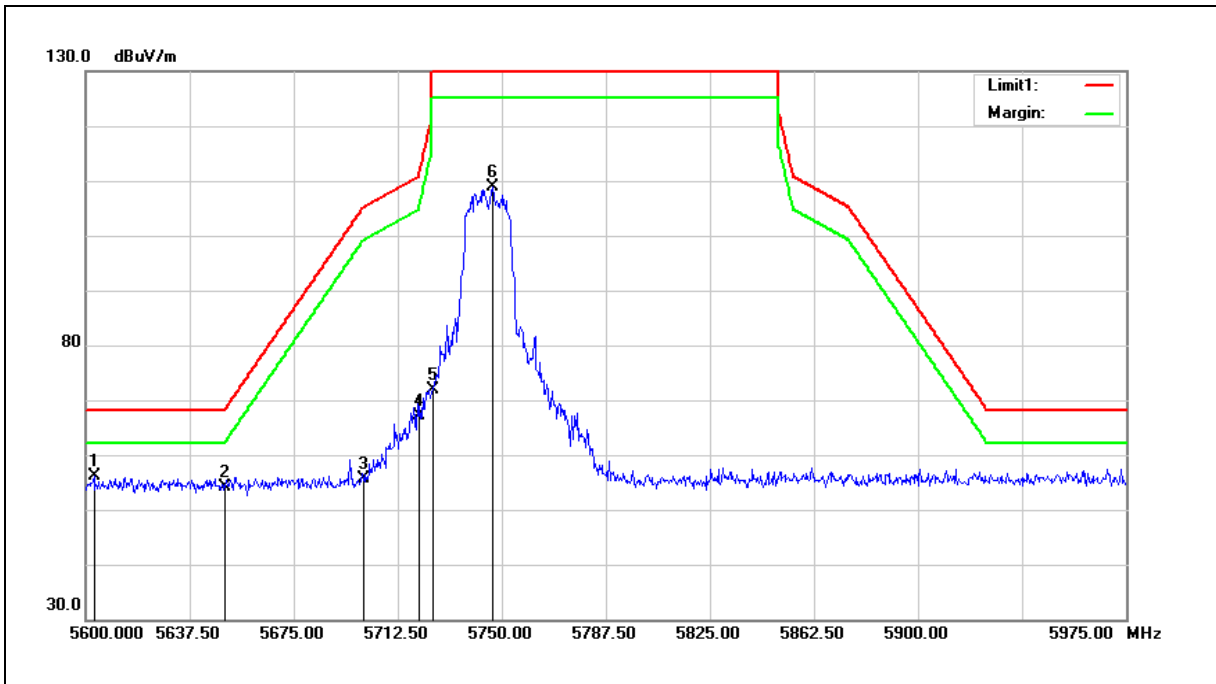

No.	Frequency (MHz)	Reading (dBuV)	Correct Factor (dB/m)	Result (dBuV/m)	Limit (dBuV/m)	Margin (dB)	Remark
1	5603.000	50.58	5.49	56.07	68.20	-12.13	peak
2	5650.000	48.58	5.58	54.16	68.20	-14.04	peak
3	5700.000	49.88	5.68	55.56	105.20	-49.64	peak
4	5720.000	61.31	5.72	67.03	110.80	-43.77	peak
5	5725.000	66.08	5.73	71.81	122.20	-50.39	peak
6	5746.625	103.08	5.78	108.86	131.20	-22.34	peak

Note:1.Result (dBuV/m) = Correct Factor (dB/m) + Reading(dBuV).

2.Correction factor (dB/m) = Antenna Factor (dB/m) + Cable loss (dB) – Pre-Amplifier gain (dB).

3.When the peak results are less than average limit, so not need to evaluate the average.

Standard:	FCC Part 15.407	Test Distance:	3 m
Test item:	Band edge		
Frequency:	5745 MHz		
Mode:	Mode 1		
Ant.Polar.:	Vertical		

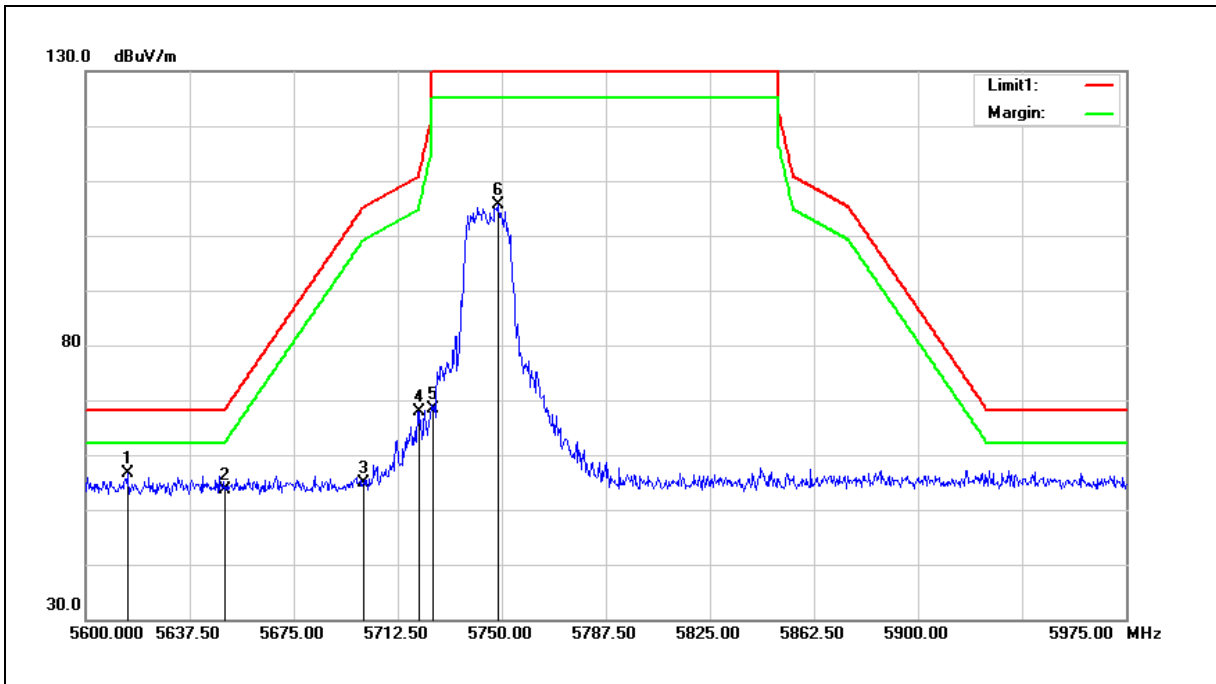

No.	Frequency (MHz)	Reading (dBuV)	Correct Factor (dB/m)	Result (dBuV/m)	Limit (dBuV/m)	Margin (dB)	Remark
1	5615.000	51.03	5.52	56.55	68.20	-11.65	peak
2	5650.000	47.93	5.58	53.51	68.20	-14.69	peak
3	5700.000	49.14	5.68	54.82	105.20	-50.38	peak
4	5720.000	62.27	5.72	67.99	110.80	-42.81	peak
5	5725.000	62.76	5.73	68.49	122.20	-53.71	peak
6	5748.500	99.94	5.78	105.72	131.20	-25.48	peak

Note:1.Result (dBuV/m) = Correct Factor (dB/m) + Reading(dBuV).

2.Correction factor (dB/m) = Antenna Factor (dB/m) + Cable loss (dB) – Pre-Amplifier gain (dB).

3.When the peak results are less than average limit, so not need to evaluate the average.

Standard:	FCC Part 15.407	Test Distance:	3 m
Test item:	Band edge		
Frequency:	5825 MHz		
Mode:	Mode 1		
Ant.Polar.:	Horizontal		

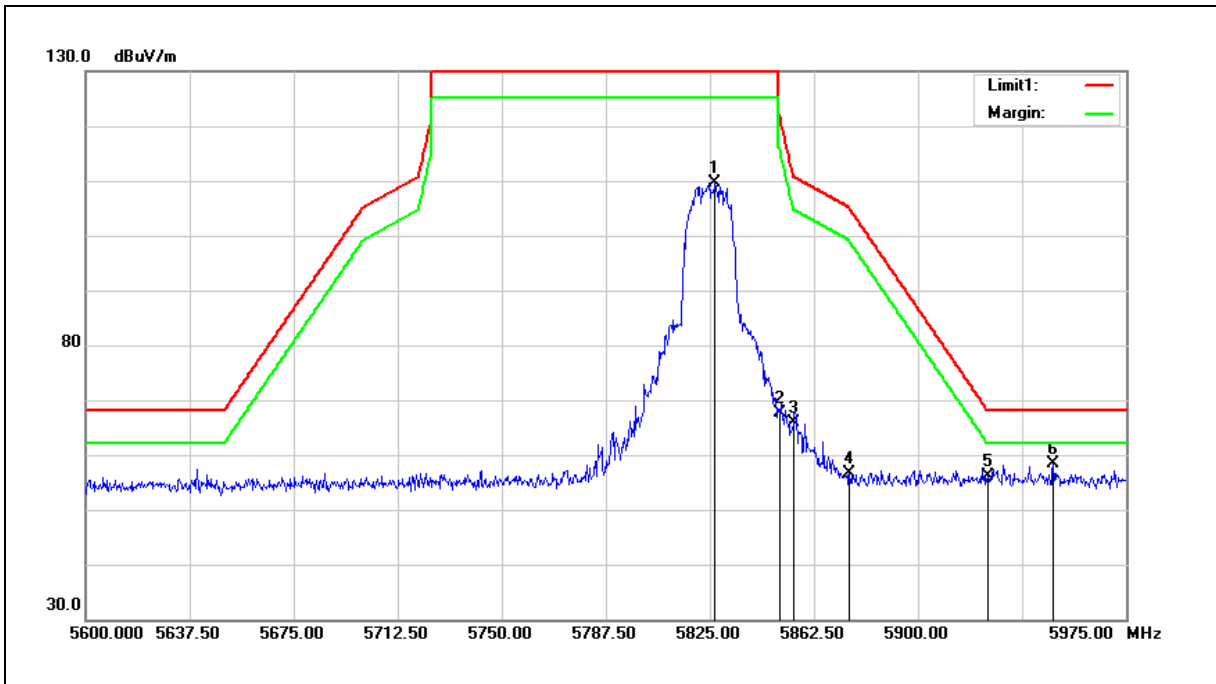

No.	Frequency (MHz)	Reading (dBuV)	Correct Factor (dB/m)	Result (dBuV/m)	Limit (dBuV/m)	Margin (dB)	Remark
1	5826.875	103.66	5.93	109.59	131.20	-21.61	peak
2	5850.000	61.64	5.99	67.63	122.20	-54.57	peak
3	5855.000	59.96	6.00	65.96	110.80	-44.84	peak
4	5875.000	50.69	6.04	56.73	105.20	-48.47	peak
5	5925.000	50.04	6.13	56.17	68.20	-12.03	peak
6	5948.750	52.16	6.18	58.34	68.20	-9.86	peak

Note:1.Result (dBuV/m) = Correct Factor (dB/m) + Reading(dBuV).

2.Correction factor (dB/m) = Antenna Factor (dB/m) + Cable loss (dB) – Pre-Amplifier gain (dB).

3.When the peak results are less than average limit, so not need to evaluate the average.

Standard:	FCC Part 15.407	Test Distance:	3 m
Test item:	Band edge		
Frequency:	5825 MHz		
Mode:	Mode 1		
Ant.Polar.:	Vertical		

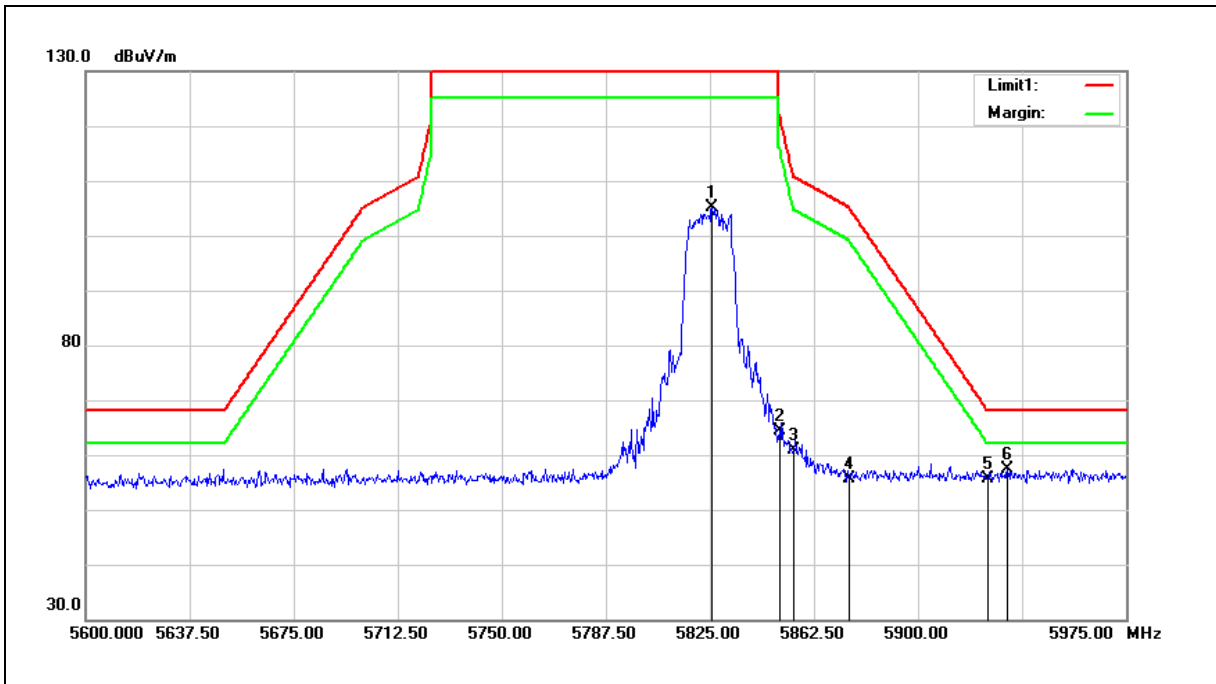

No.	Frequency (MHz)	Reading (dBuV)	Correct Factor (dB/m)	Result (dBuV/m)	Limit (dBuV/m)	Margin (dB)	Remark
1	5825.750	99.18	5.93	105.11	131.20	-26.09	peak
2	5850.000	58.40	5.99	64.39	122.20	-57.81	peak
3	5855.000	54.77	6.00	60.77	110.80	-50.03	peak
4	5875.000	49.55	6.04	55.59	105.20	-49.61	peak
5	5925.000	49.49	6.13	55.62	68.20	-12.58	peak
6	5932.250	51.22	6.15	57.37	68.20	-10.83	peak

Note:1.Result (dBuV/m) = Correct Factor (dB/m) + Reading(dBuV).

2.Correction factor (dB/m) = Antenna Factor (dB/m) + Cable loss (dB) – Pre-Amplifier gain (dB).

3.When the peak results are less than average limit, so not need to evaluate the average.

Standard:	FCC Part 15.407	Test Distance:	3 m
Test item:	Band edge		
Frequency:	5180 MHz		
Mode:	Mode 2		
Ant.Polar.:	Horizontal		

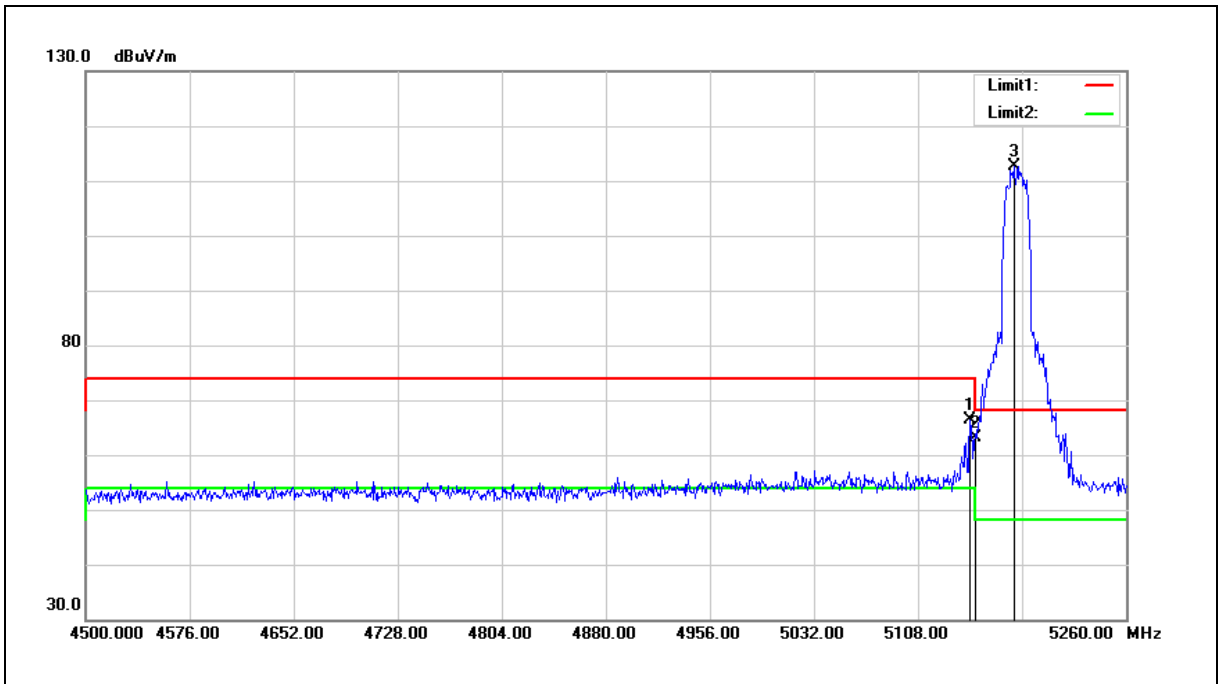

No.	Frequency (MHz)	Reading (dBuV)	Correct Factor (dB/m)	Result (dBuV/m)	Limit (dBuV/m)	Margin (dB)	Remark
1	5146.000	61.70	4.80	66.50	74.00	-7.50	peak
2	5150.000	58.35	4.80	63.15	74.00	-10.85	peak
3	5177.920	107.69	4.85	112.54	68.20	44.34	peak

Note:1.Result (dBuV/m) = Correct Factor (dB/m) + Reading(dBuV).

2.Correction factor (dB/m) = Antenna Factor (dB/m) + Cable loss (dB) – Pre-Amplifier gain (dB).

3.When the peak results are less than average limit, so not need to evaluate the average.

Standard:	FCC Part 15.407	Test Distance:	3 m
Test item:	Band edge		
Frequency:	5180 MHz		
Mode:	Mode 2		
Ant.Polar.:	Vertical		

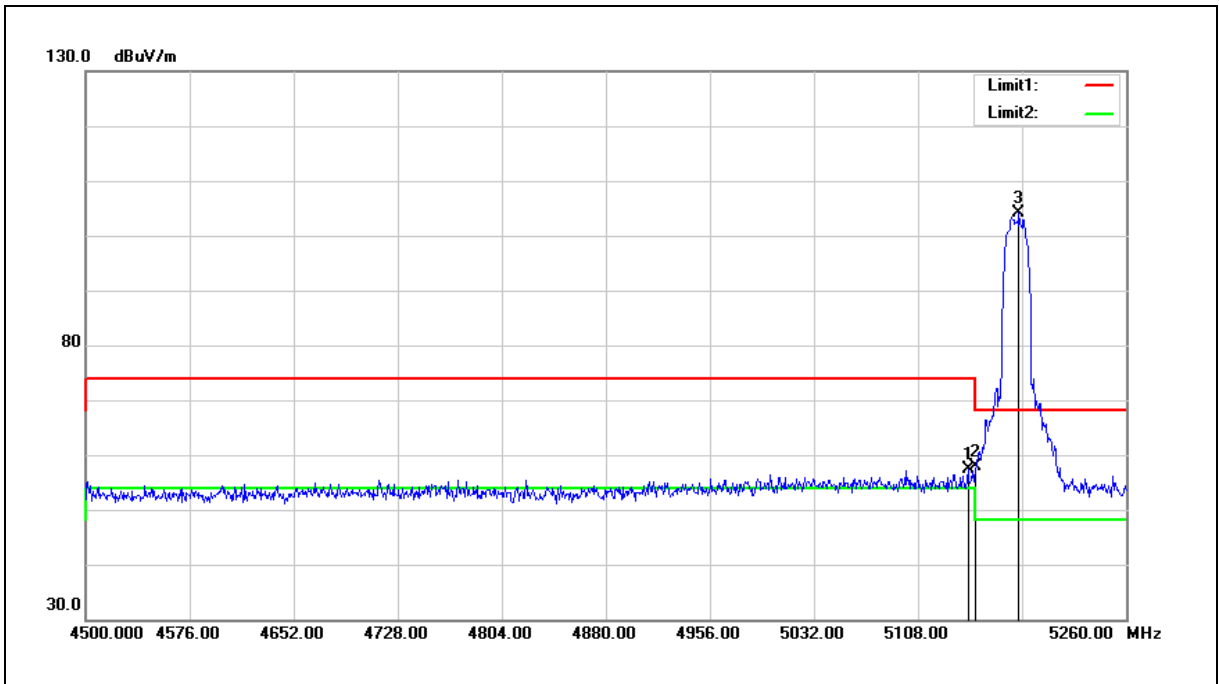

No.	Frequency (MHz)	Reading (dBuV)	Correct Factor (dB/m)	Result (dBuV/m)	Limit (dBuV/m)	Margin (dB)	Remark
1	5144.480	52.49	4.79	57.28	74.00	-16.72	peak
2	5150.000	53.08	4.80	57.88	74.00	-16.12	peak
3	5181.720	99.24	4.85	104.09	68.20	35.89	peak

Note:1.Result (dBuV/m) = Correct Factor (dB/m) + Reading(dBuV).

2.Correction factor (dB/m) = Antenna Factor (dB/m) + Cable loss (dB) – Pre-Amplifier gain (dB).

3.When the peak results are less than average limit, so not need to evaluate the average.

Standard:	FCC Part 15.407	Test Distance:	3 m
Test item:	Band edge		
Frequency:	5240 MHz		
Mode:	Mode 2		
Ant.Polar.:	Horizontal		

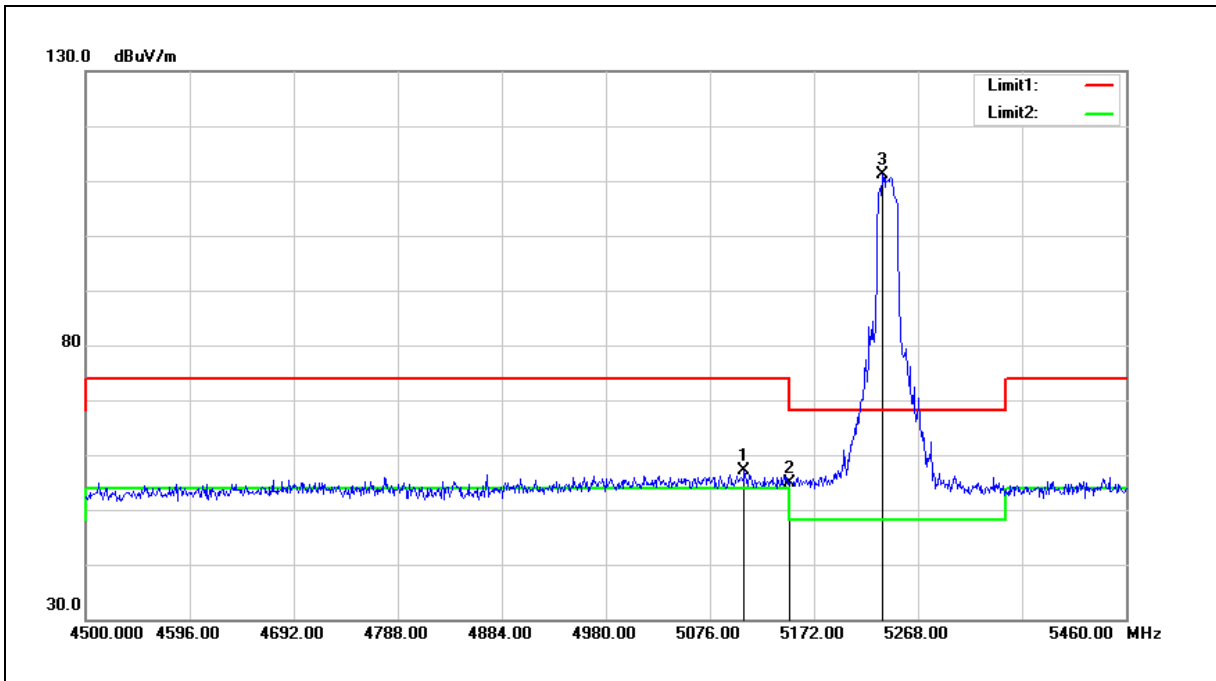

No.	Frequency (MHz)	Reading (dBuV)	Correct Factor (dB/m)	Result (dBuV/m)	Limit (dBuV/m)	Margin (dB)	Remark
1	5107.680	52.39	4.75	57.14	74.00	-16.86	peak
2	5150.000	50.18	4.80	54.98	74.00	-19.02	peak
3	5235.360	106.10	4.93	111.03	68.20	42.83	peak

Note:1.Result (dBuV/m) = Correct Factor (dB/m) + Reading(dBuV).

2.Correction factor (dB/m) = Antenna Factor (dB/m) + Cable loss (dB) – Pre-Amplifier gain (dB).

3.When the peak results are less than average limit, so not need to evaluate the average.

Standard:	FCC Part 15.407	Test Distance:	3 m
Test item:	Band edge		
Frequency:	5240 MHz		
Mode:	Mode 2		
Ant.Polar.:	Vertical		

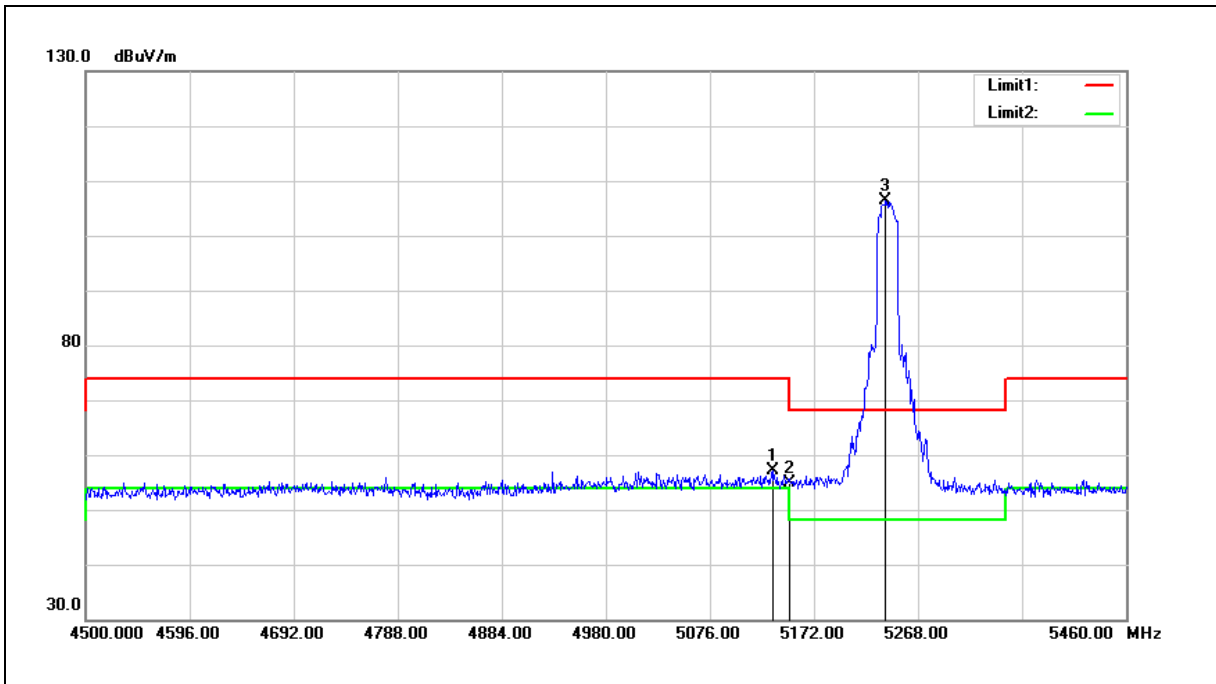

No.	Frequency (MHz)	Reading (dBuV)	Correct Factor (dB/m)	Result (dBuV/m)	Limit (dBuV/m)	Margin (dB)	Remark
1	5133.600	52.36	4.78	57.14	74.00	-16.86	peak
2	5150.000	50.18	4.80	54.98	74.00	-19.02	peak
3	5238.240	101.42	4.93	106.35	68.20	38.15	peak

Note:1.Result (dBuV/m) = Correct Factor (dB/m) + Reading(dBuV).

2.Correction factor (dB/m) = Antenna Factor (dB/m) + Cable loss (dB) – Pre-Amplifier gain (dB).

3.When the peak results are less than average limit, so not need to evaluate the average.

Standard:	FCC Part 15.407	Test Distance:	3 m
Test item:	Band edge		
Frequency:	5745 MHz		
Mode:	Mode 2		
Ant.Polar.:	Horizontal		

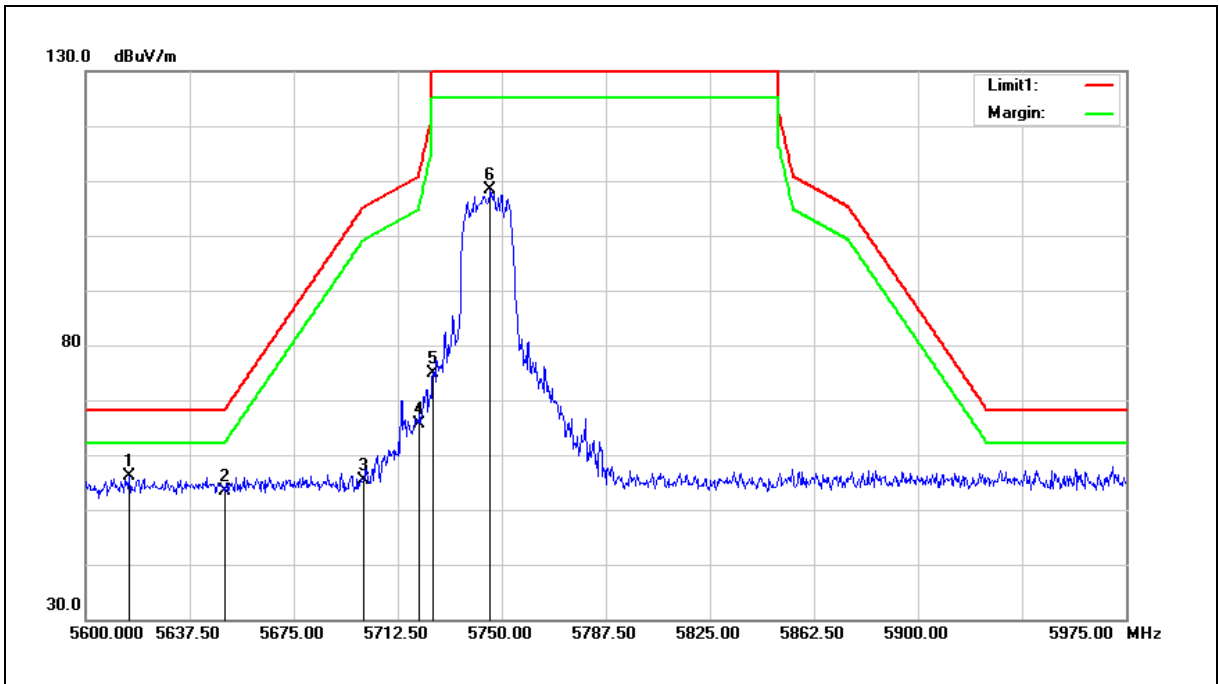

No.	Frequency (MHz)	Reading (dBuV)	Correct Factor (dB/m)	Result (dBuV/m)	Limit (dBuV/m)	Margin (dB)	Remark
1	5615.750	50.60	5.52	56.12	68.20	-12.08	peak
2	5650.000	47.92	5.58	53.50	68.20	-14.70	peak
3	5700.000	49.72	5.68	55.40	105.20	-49.80	peak
4	5720.000	59.94	5.72	65.66	110.80	-45.14	peak
5	5725.000	69.23	5.73	74.96	122.20	-47.24	peak
6	5745.875	102.71	5.78	108.49	131.20	-22.71	peak

Note:1.Result (dBuV/m) = Correct Factor (dB/m) + Reading(dBuV).

2.Correction factor (dB/m) = Antenna Factor (dB/m) + Cable loss (dB) – Pre-Amplifier gain (dB).

3.When the peak results are less than average limit, so not need to evaluate the average.

Standard:	FCC Part 15.407	Test Distance:	3 m
Test item:	Band edge		
Frequency:	5745 MHz		
Mode:	Mode 2		
Ant.Polar.:	Vertical		

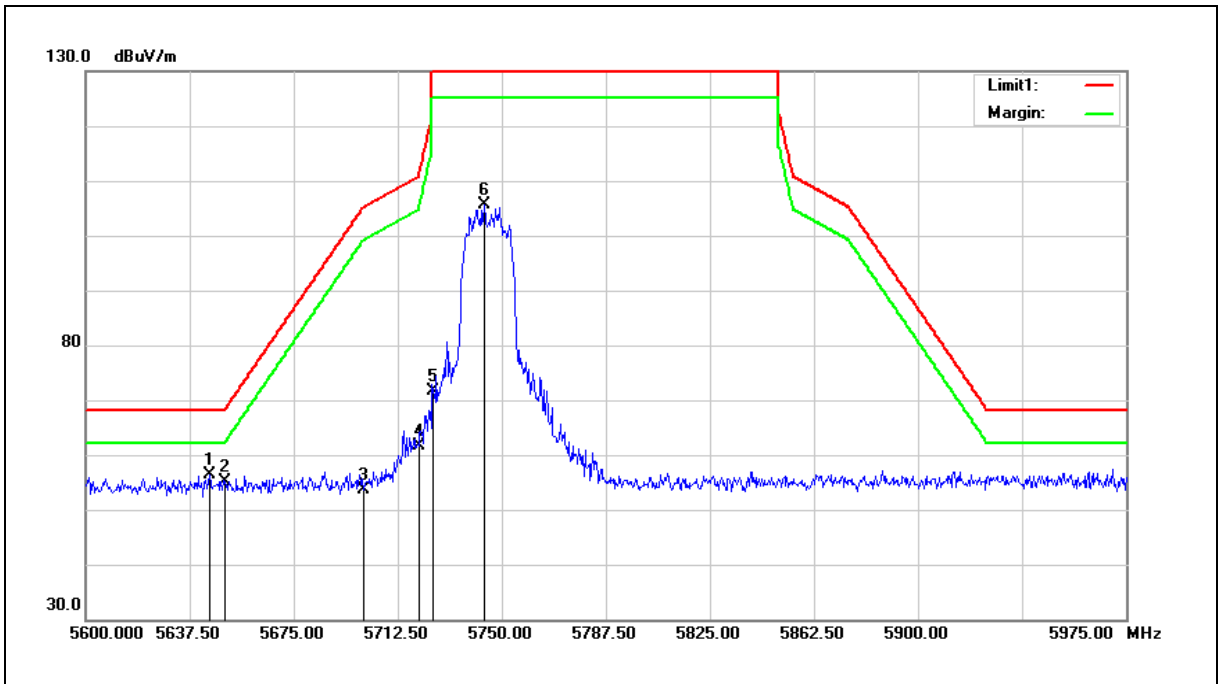

No.	Frequency (MHz)	Reading (dBuV)	Correct Factor (dB/m)	Result (dBuV/m)	Limit (dBuV/m)	Margin (dB)	Remark
1	5644.625	50.69	5.57	56.26	68.20	-11.94	peak
2	5650.000	49.58	5.58	55.16	68.20	-13.04	peak
3	5700.000	48.02	5.68	53.70	105.20	-51.50	peak
4	5720.000	55.88	5.72	61.60	110.80	-49.20	peak
5	5725.000	65.96	5.73	71.69	122.20	-50.51	peak
6	5743.625	99.86	5.77	105.63	131.20	-25.57	peak

Note:1.Result (dBuV/m) = Correct Factor (dB/m) + Reading(dBuV).

2.Correction factor (dB/m) = Antenna Factor (dB/m) + Cable loss (dB) – Pre-Amplifier gain (dB).

3.When the peak results are less than average limit, so not need to evaluate the average.

Standard:	FCC Part 15.407	Test Distance:	3 m
Test item:	Band edge		
Frequency:	5825 MHz		
Mode:	Mode 2		
Ant.Polar.:	Horizontal		

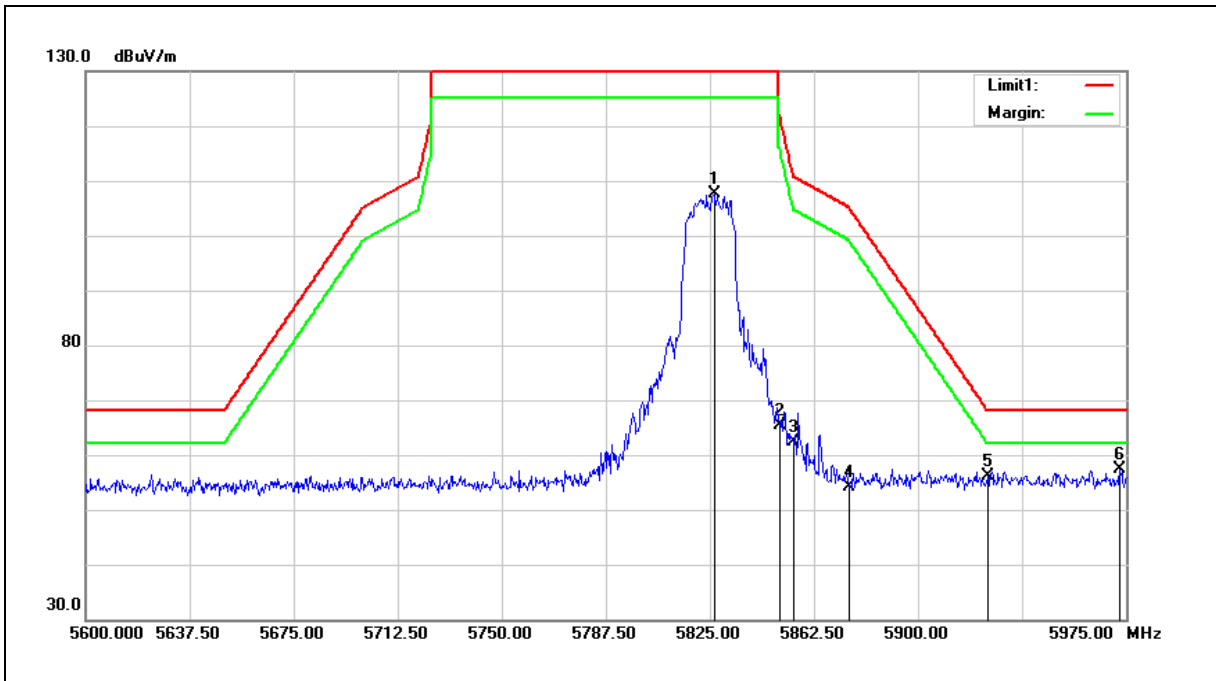

No.	Frequency (MHz)	Reading (dBuV)	Correct Factor (dB/m)	Result (dBuV/m)	Limit (dBuV/m)	Margin (dB)	Remark
1	5826.500	101.64	5.93	107.57	131.20	-23.63	peak
2	5850.000	59.45	5.99	65.44	122.20	-56.76	peak
3	5855.000	56.42	6.00	62.42	110.80	-48.38	peak
4	5875.000	48.18	6.04	54.22	105.20	-50.98	peak
5	5925.000	49.92	6.13	56.05	68.20	-12.15	peak
6	5972.750	51.22	6.23	57.45	68.20	-10.75	peak

Note:1.Result (dBuV/m) = Correct Factor (dB/m) + Reading(dBuV).

2.Correction factor (dB/m) = Antenna Factor (dB/m) + Cable loss (dB) – Pre-Amplifier gain (dB).

3.When the peak results are less than average limit, so not need to evaluate the average.

Standard:	FCC Part 15.407	Test Distance:	3 m
Test item:	Band edge		
Frequency:	5825 MHz		
Mode:	Mode 2		
Ant.Polar.:	Vertical		

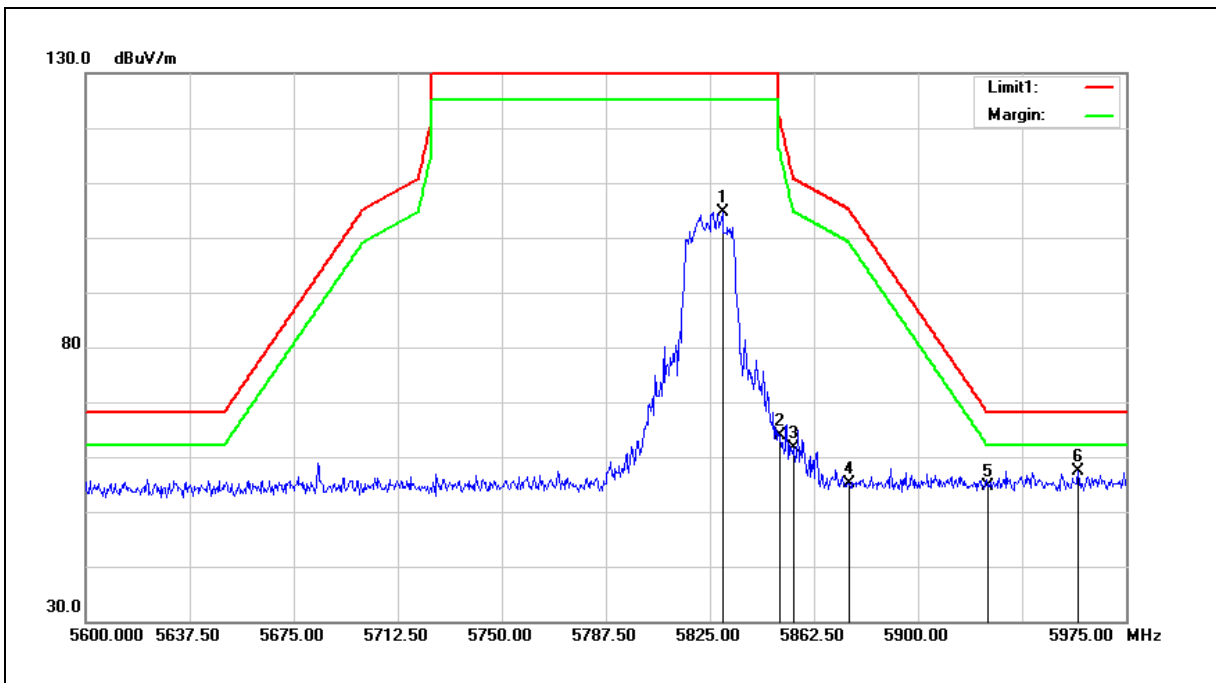

No.	Frequency (MHz)	Reading (dBuV)	Correct Factor (dB/m)	Result (dBuV/m)	Limit (dBuV/m)	Margin (dB)	Remark
1	5829.500	98.68	5.94	104.62	131.20	-26.58	peak
2	5850.000	57.93	5.99	63.92	122.20	-58.28	peak
3	5855.000	55.71	6.00	61.71	110.80	-49.09	peak
4	5875.000	49.13	6.04	55.17	105.20	-50.03	peak
5	5925.000	48.52	6.13	54.65	68.20	-13.55	peak
6	5957.750	51.26	6.20	57.46	68.20	-10.74	peak

Note:1.Result (dBuV/m) = Correct Factor (dB/m) + Reading(dBuV).

2.Correction factor (dB/m) = Antenna Factor (dB/m) + Cable loss (dB) – Pre-Amplifier gain (dB).

3.When the peak results are less than average limit, so not need to evaluate the average.

Average

Standard:	FCC Part 15.407	Test Distance:	3 m
Test item:	Band edge		
Frequency:	5180 MHz		
Mode:	Mode 1		
Ant.Polar.:	Horizontal		

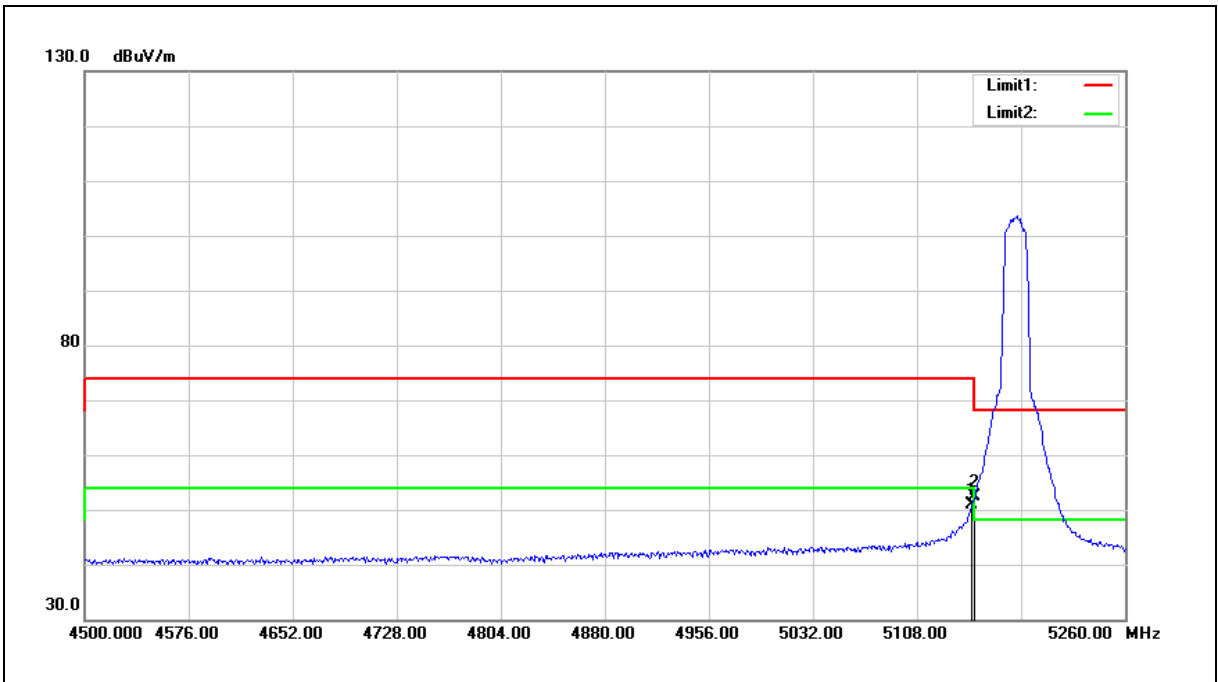

No.	Frequency (MHz)	Reading (dBuV)	Correct Factor (dB/m)	Result (dBuV/m)	Limit (dBuV/m)	Margin (dB)	Remark
1	5148.280	46.12	4.80	50.92	54.00	-3.08	AVG
2	5150.000	47.56	4.80	52.36	54.00	-1.64	AVG

Note:1.Result (dBuV/m) = Correct Factor (dB/m) + Reading(dBuV).

2.Correction factor (dB/m) = Antenna Factor (dB/m) + Cable loss (dB) – Pre-Amplifier gain (dB).

3.When the peak results are less than average limit, so not need to evaluate the average.

Standard:	FCC Part 15.407	Test Distance:	3 m
Test item:	Band edge		
Frequency:	5180 MHz		
Mode:	Mode 1		
Ant.Polar.:	Vertical		

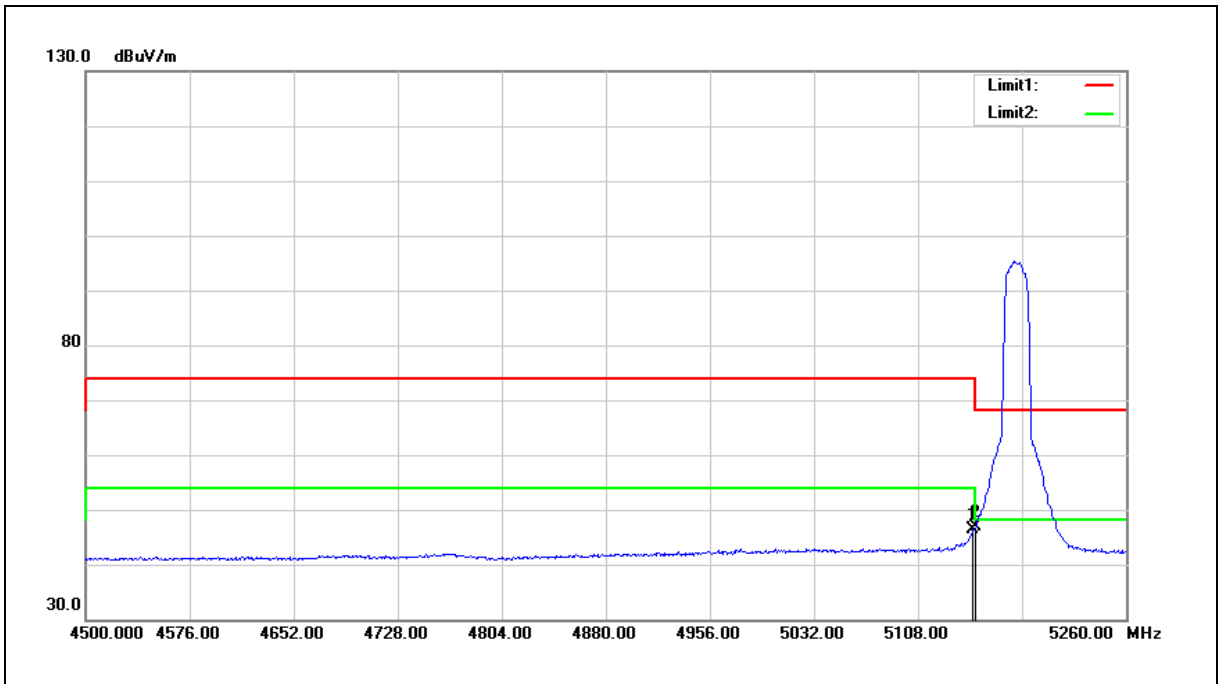

No.	Frequency (MHz)	Reading (dBuV)	Correct Factor (dB/m)	Result (dBuV/m)	Limit (dBuV/m)	Margin (dB)	Remark
1	5148.280	41.65	4.80	46.45	54.00	-7.55	AVG
2	5150.000	42.08	4.80	46.88	54.00	-7.12	AVG

Note:1.Result (dBuV/m) = Correct Factor (dB/m) + Reading(dBuV).

2.Correction factor (dB/m) = Antenna Factor (dB/m) + Cable loss (dB) – Pre-Amplifier gain (dB).

3.When the peak results are less than average limit, so not need to evaluate the average.

Standard:	FCC Part 15.407	Test Distance:	3 m
Test item:	Band edge		
Frequency:	5240 MHz		
Mode:	Mode 1		
Ant.Polar.:	Horizontal		

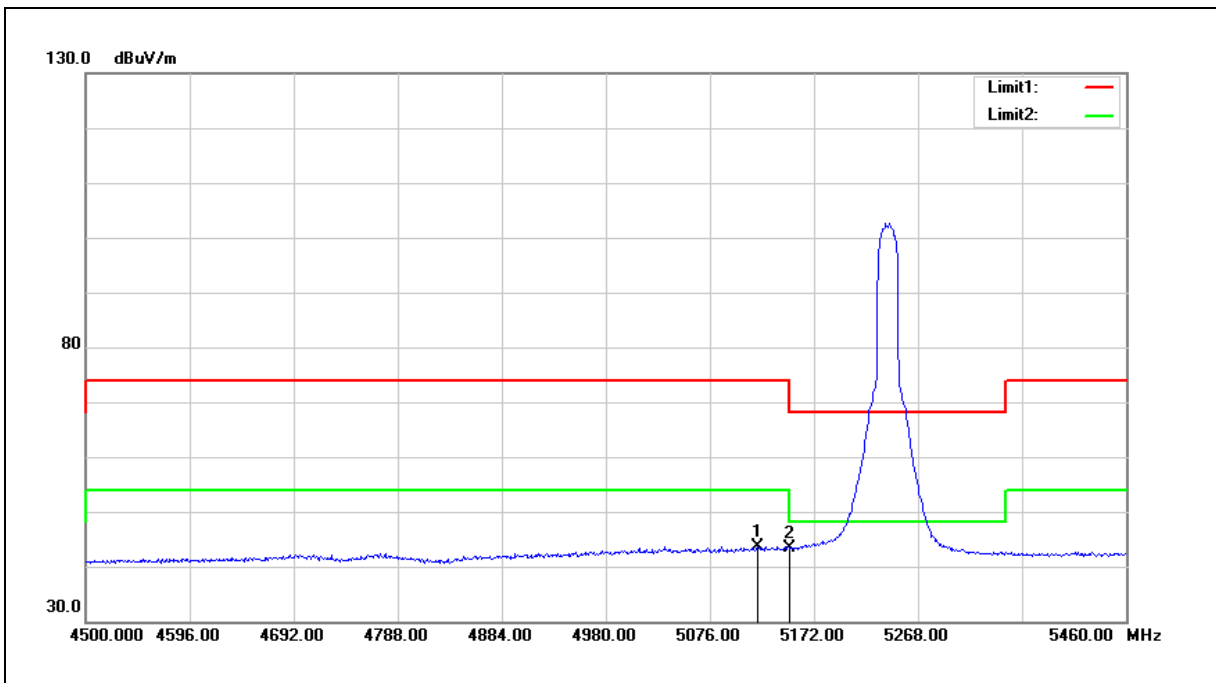

No.	Frequency (MHz)	Reading (dBuV)	Correct Factor (dB/m)	Result (dBuV/m)	Limit (dBuV/m)	Margin (dB)	Remark
1	5120.160	38.86	4.76	43.62	54.00	-10.38	AVG
2	5150.000	38.56	4.80	43.36	54.00	-10.64	AVG

Note:1.Result (dBuV/m) = Correct Factor (dB/m) + Reading(dBuV).

2.Correction factor (dB/m) = Antenna Factor (dB/m) + Cable loss (dB) – Pre-Amplifier gain (dB).

3.When the peak results are less than average limit, so not need to evaluate the average.

Standard:	FCC Part 15.407	Test Distance:	3 m
Test item:	Band edge		
Frequency:	5240 MHz		
Mode:	Mode 1		
Ant.Polar.:	Vertical		

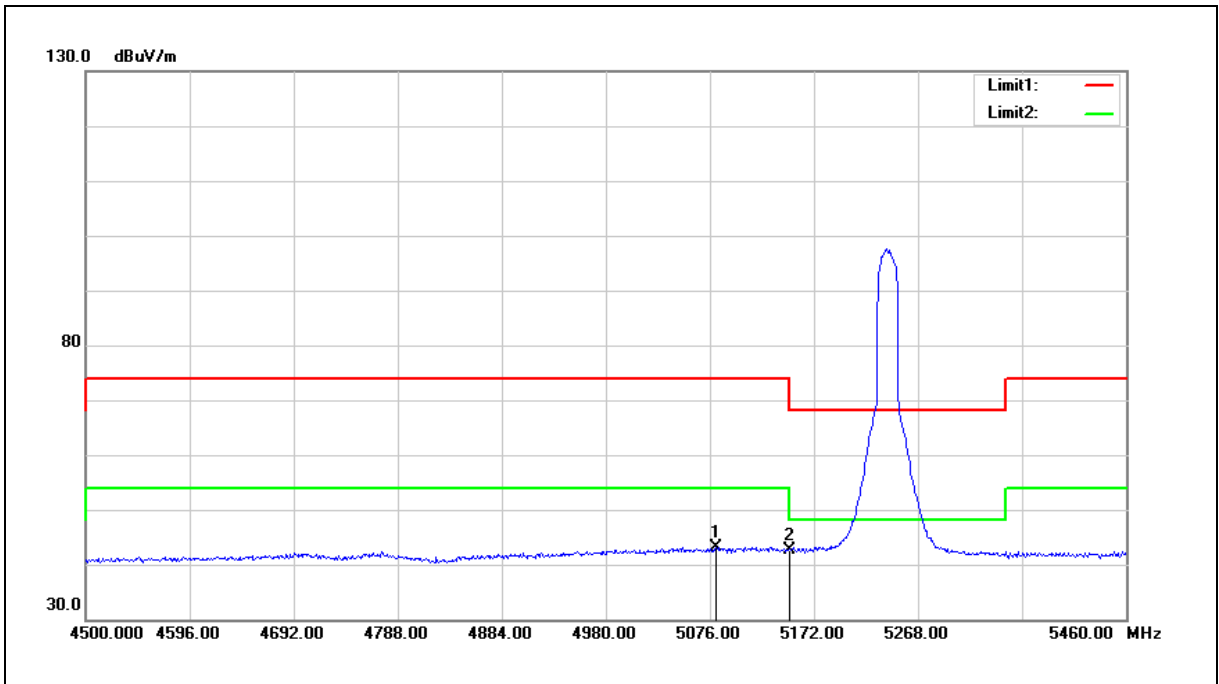

No.	Frequency (MHz)	Reading (dBuV)	Correct Factor (dB/m)	Result (dBuV/m)	Limit (dBuV/m)	Margin (dB)	Remark
1	5081.760	38.48	4.71	43.19	54.00	-10.81	AVG
2	5150.000	37.83	4.80	42.63	54.00	-11.37	AVG

Note:1.Result (dBuV/m) = Correct Factor (dB/m) + Reading(dBuV).

2.Correction factor (dB/m) = Antenna Factor (dB/m) + Cable loss (dB) – Pre-Amplifier gain (dB).

3.When the peak results are less than average limit, so not need to evaluate the average.

Standard:	FCC Part 15.407	Test Distance:	3 m
Test item:	Band edge		
Frequency:	5180 MHz		
Mode:	Mode 2		
Ant.Polar.:	Horizontal		

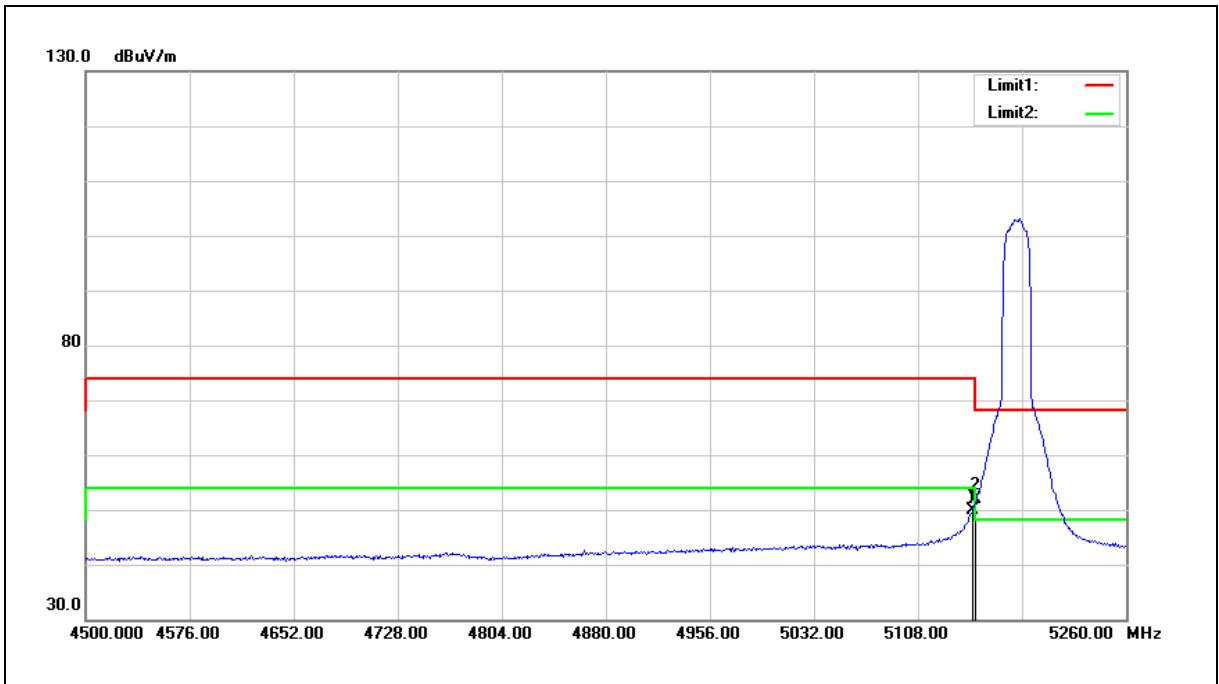

No.	Frequency (MHz)	Reading (dBuV)	Correct Factor (dB/m)	Result (dBuV/m)	Limit (dBuV/m)	Margin (dB)	Remark
1	5148.280	45.20	4.80	50.00	54.00	-4.00	AVG
2	5150.000	47.14	4.80	51.94	54.00	-2.06	AVG

Note:1.Result (dBuV/m) = Correct Factor (dB/m) + Reading(dBuV).

2.Correction factor (dB/m) = Antenna Factor (dB/m) + Cable loss (dB) – Pre-Amplifier gain (dB).

3.When the peak results are less than average limit, so not need to evaluate the average.

Standard:	FCC Part 15.407	Test Distance:	3 m
Test item:	Band edge		
Frequency:	5180 MHz		
Mode:	Mode 2		
Ant.Polar.:	Vertical		

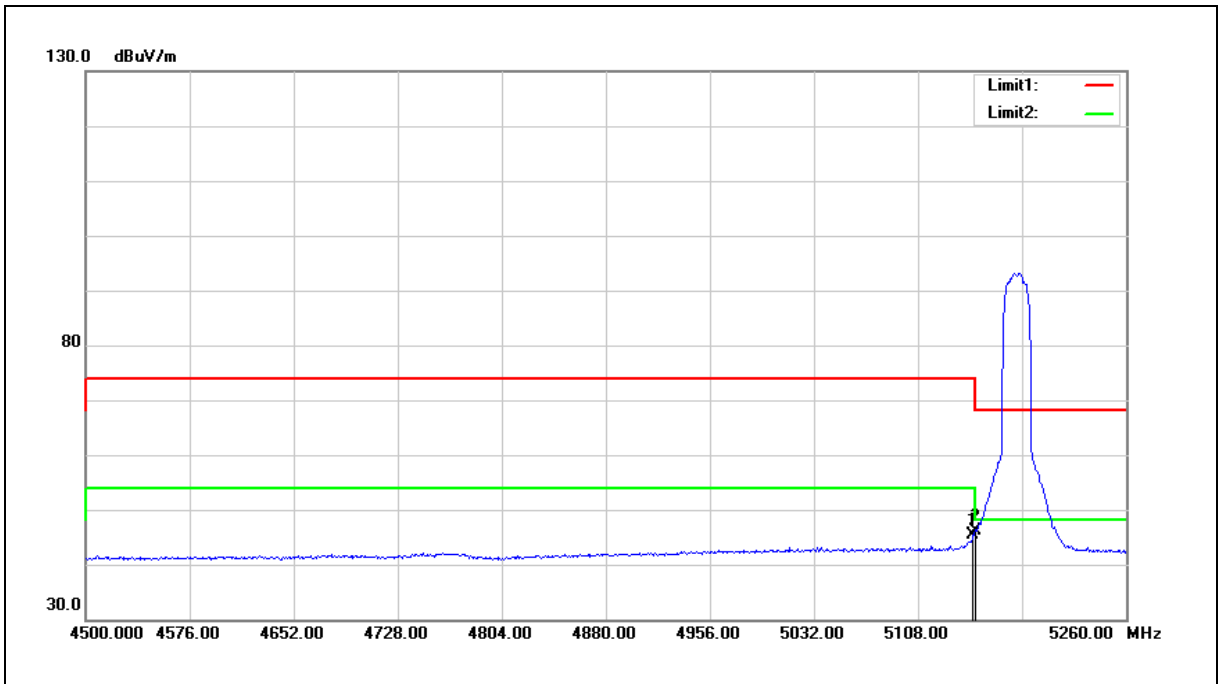

No.	Frequency (MHz)	Reading (dBuV)	Correct Factor (dB/m)	Result (dBuV/m)	Limit (dBuV/m)	Margin (dB)	Remark
1	5148.280	40.57	4.80	45.37	54.00	-8.63	AVG
2	5150.000	41.25	4.80	46.05	54.00	-7.95	AVG

Note:1.Result (dBuV/m) = Correct Factor (dB/m) + Reading(dBuV).

2.Correction factor (dB/m) = Antenna Factor (dB/m) + Cable loss (dB) – Pre-Amplifier gain (dB).

3.When the peak results are less than average limit, so not need to evaluate the average.

Standard:	FCC Part 15.407	Test Distance:	3 m
Test item:	Band edge		
Frequency:	5240 MHz		
Mode:	Mode 2		
Ant.Polar.:	Horizontal		

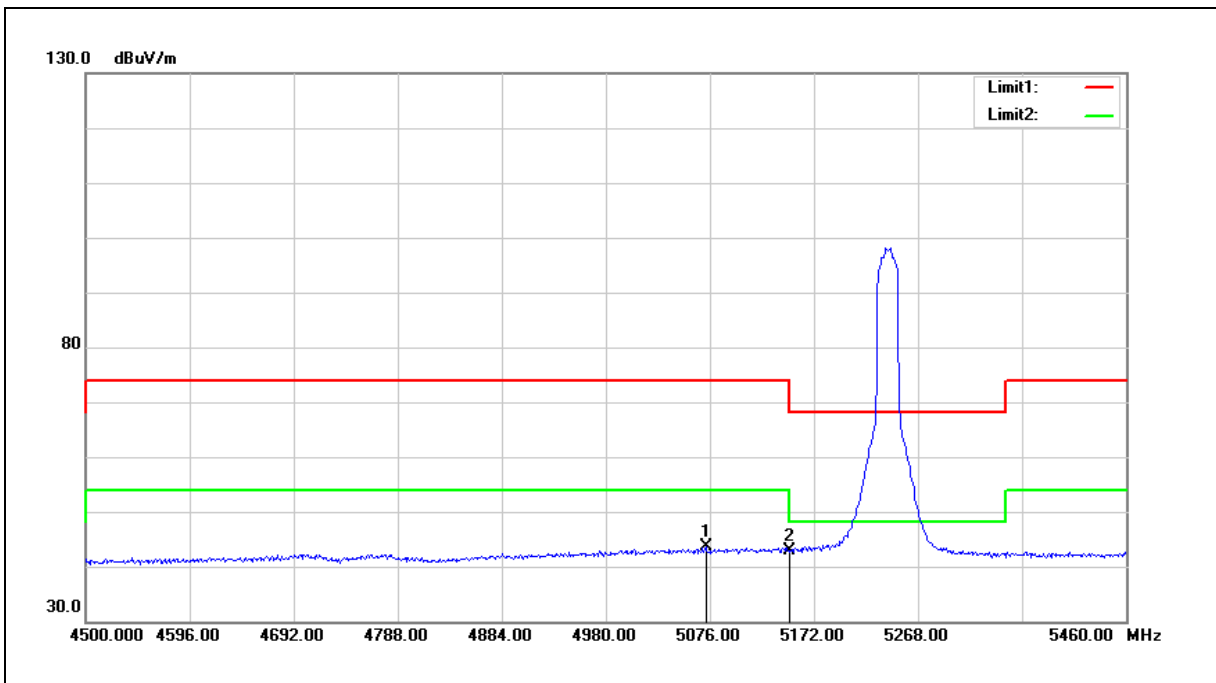

No.	Frequency (MHz)	Reading (dBuV)	Correct Factor (dB/m)	Result (dBuV/m)	Limit (dBuV/m)	Margin (dB)	Remark
1	5072.160	38.89	4.69	43.58	54.00	-10.42	AVG
2	5150.000	38.13	4.80	42.93	54.00	-11.07	AVG

Note:1.Result (dBuV/m) = Correct Factor (dB/m) + Reading(dBuV).

2.Correction factor (dB/m) = Antenna Factor (dB/m) + Cable loss (dB) – Pre-Amplifier gain (dB).

3.When the peak results are less than average limit, so not need to evaluate the average.

Standard:	FCC Part 15.407	Test Distance:	3 m
Test item:	Band edge		
Frequency:	5240 MHz		
Mode:	Mode 2		
Ant.Polar.:	Vertical		

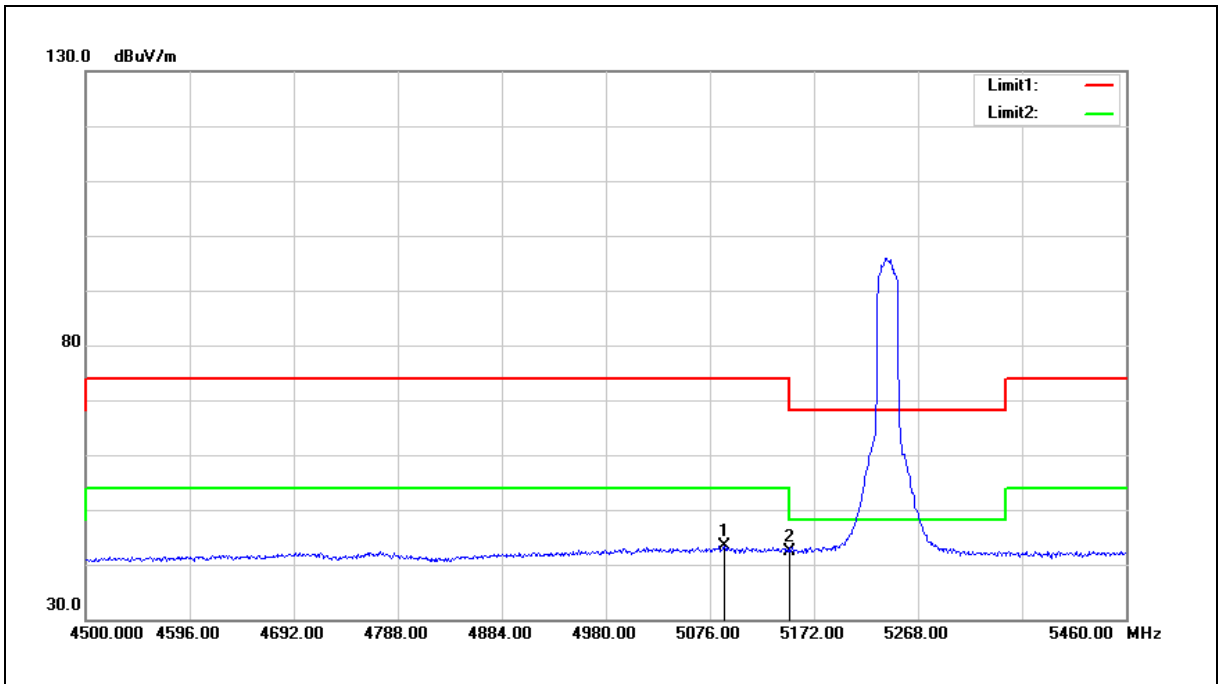

No.	Frequency (MHz)	Reading (dBuV)	Correct Factor (dB/m)	Result (dBuV/m)	Limit (dBuV/m)	Margin (dB)	Remark
1	5089.440	38.58	4.72	43.30	54.00	-10.70	AVG
2	5150.000	37.65	4.80	42.45	54.00	-11.55	AVG

Note:1.Result (dBuV/m) = Correct Factor (dB/m) + Reading(dBuV).

2.Correction factor (dB/m) = Antenna Factor (dB/m) + Cable loss (dB) – Pre-Amplifier gain (dB).

3.When the peak results are less than average limit, so not need to evaluate the average.

5.3 Conducted Test Results

Maximum Conducted Output Power Measurement

Test Mode	Frequency (MHz)	RF Power setting in Test Software	Test Software Version
		Chain 0	
Mode 1	5180	15.00	MForm V1.16.1.6
	5200	17.00	
	5240	17.00	
	5745	17.00	
	5785	17.00	
	5825	17.00	
Mode 2	5180	16.00	
	5200	17.00	
	5240	17.00	
	5745	17.00	
	5785	17.00	
	5825	17.00	
Mode 3	5180	16.00	
	5200	16.00	
	5240	16.00	
	5745	16.00	
	5785	16.00	
	5825	16.00	
Mode 4	5180	16.00	
	5200	16.00	
	5240	16.00	
	5745	16.00	
	5785	16.00	
	5825	16.00	

Test Mode	Data Rate	Frequency (MHz)	Chain 0		Limit (dBm)
			(dBm)	(W)	
Mode 1	6 M	5180	18.41	0.069	≤ 30.00
		5200	20.61	0.115	≤ 30.00
		5240	20.59	0.115	≤ 30.00
		5745	20.36	0.109	≤ 30.00
		5785	20.35	0.108	≤ 30.00
		5825	20.41	0.110	≤ 30.00
Mode 2	6.5 M	5180	18.27	0.067	≤ 30.00
		5200	19.32	0.086	≤ 30.00
		5240	19.41	0.087	≤ 30.00
		5745	19.19	0.083	≤ 30.00
		5785	19.20	0.083	≤ 30.00
		5825	19.31	0.085	≤ 30.00
Mode 3	6.5 M	5180	18.31	0.068	≤ 30.00
		5200	19.24	0.084	≤ 30.00
		5240	19.32	0.086	≤ 30.00
		5745	19.24	0.084	≤ 30.00
		5785	19.24	0.084	≤ 30.00
		5825	19.29	0.085	≤ 30.00
Mode 4	MCS0	5180	18.22	0.066	≤ 30.00
		5200	19.39	0.087	≤ 30.00
		5240	19.40	0.087	≤ 30.00
		5745	19.18	0.083	≤ 30.00
		5785	19.11	0.081	≤ 30.00
		5825	19.23	0.084	≤ 30.00

Note: The relevant measured result has the offset with cable loss already.

26 dB RF Bandwidth Measurement & 99 % Occupied Bandwidth Measurement

Test Mode	Frequency (MHz)	26 dB Bandwidth (MHz)	99 % Occupied Bandwidth (MHz)
		Chain 0	Chain 0
Mode 1	5180	20.250	16.893
	5200	26.560	17.087
	5240	28.830	17.206
Mode 2	5180	20.610	17.781
	5200	20.730	17.853
	5240	20.840	17.834

Note: The 99 % occupied bandwidth not crossed 5250 MHz.

■ Test Graphs

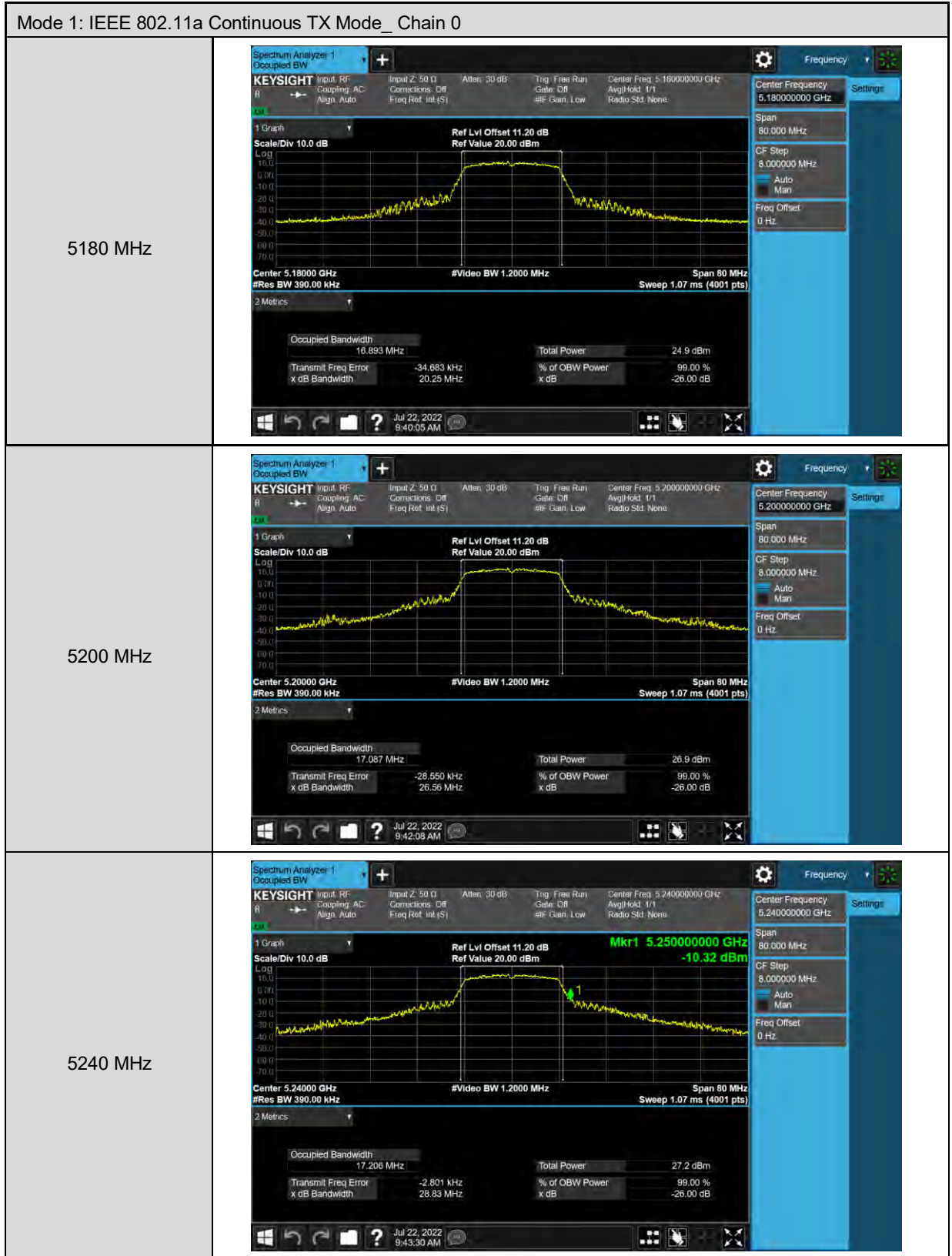

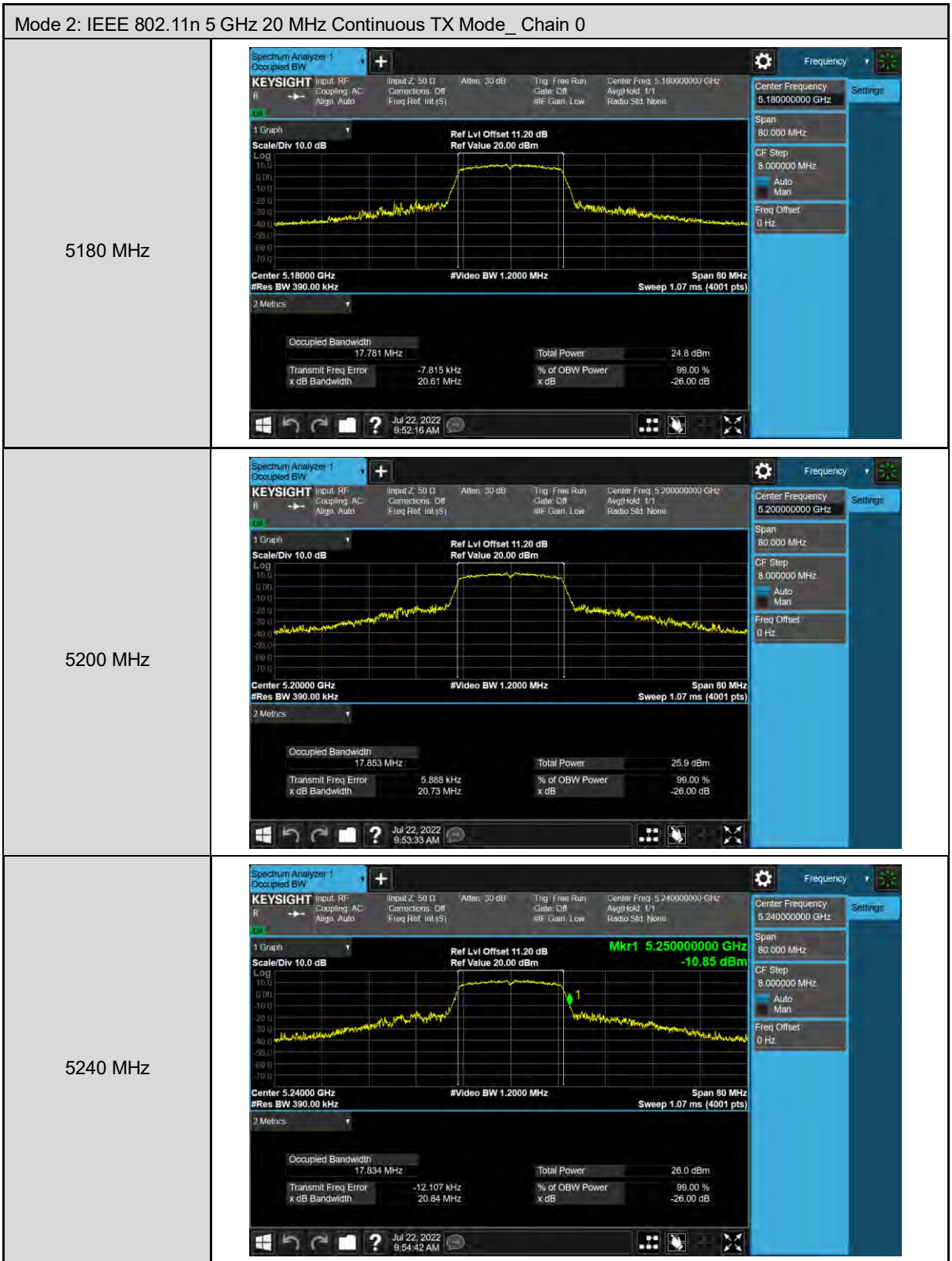

6 dB RF Bandwidth Measurement

Test Mode	Frequency (MHz)	6 dB RF Bandwidth (kHz)	Limit (kHz)
		Chain 0	
Mode 1	5745	15080	≥ 500
	5785	15070	≥ 500
	5825	15140	≥ 500
Mode 2	5745	15100	≥ 500
	5785	14720	≥ 500
	5825	15130	≥ 500

■ Test Graphs

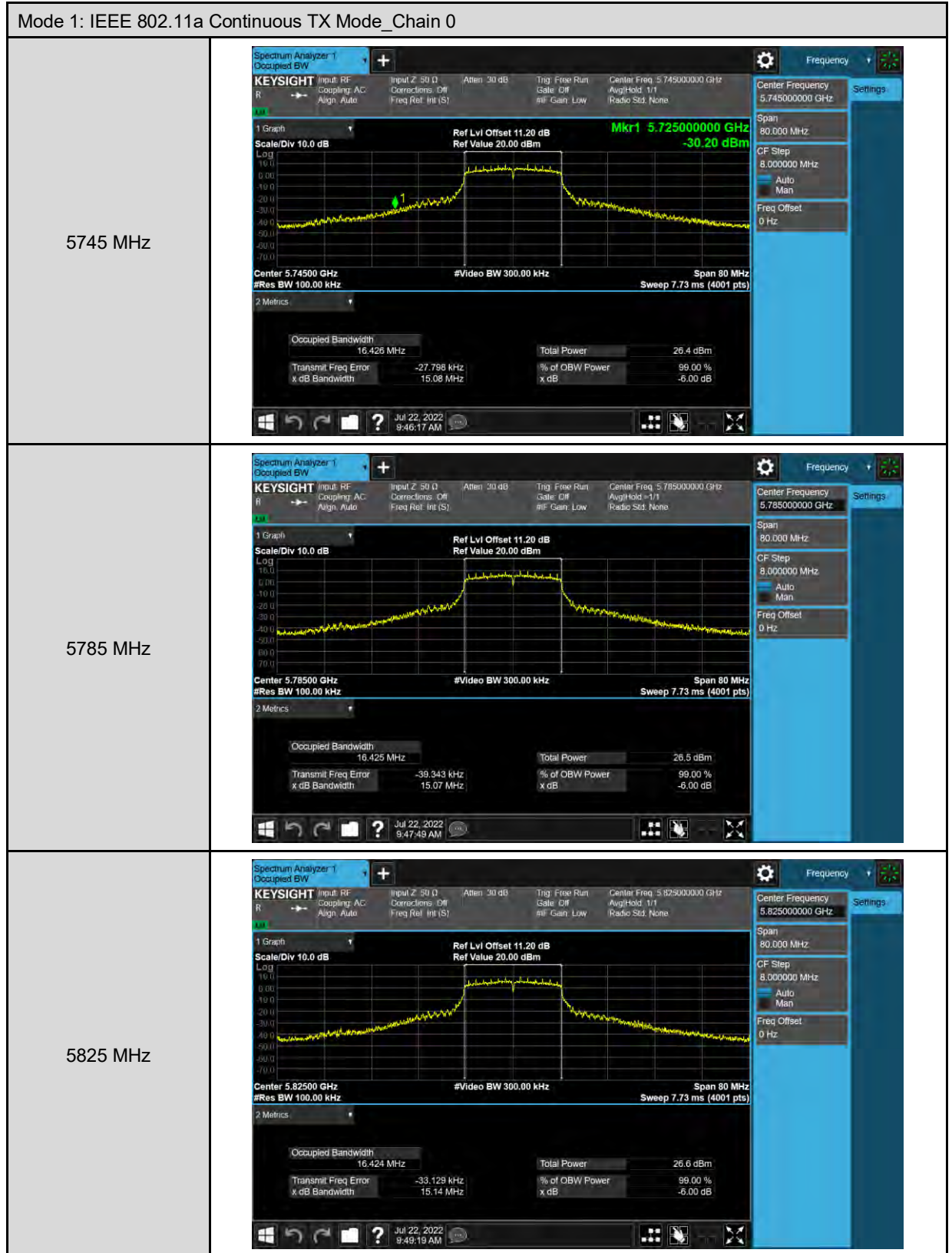

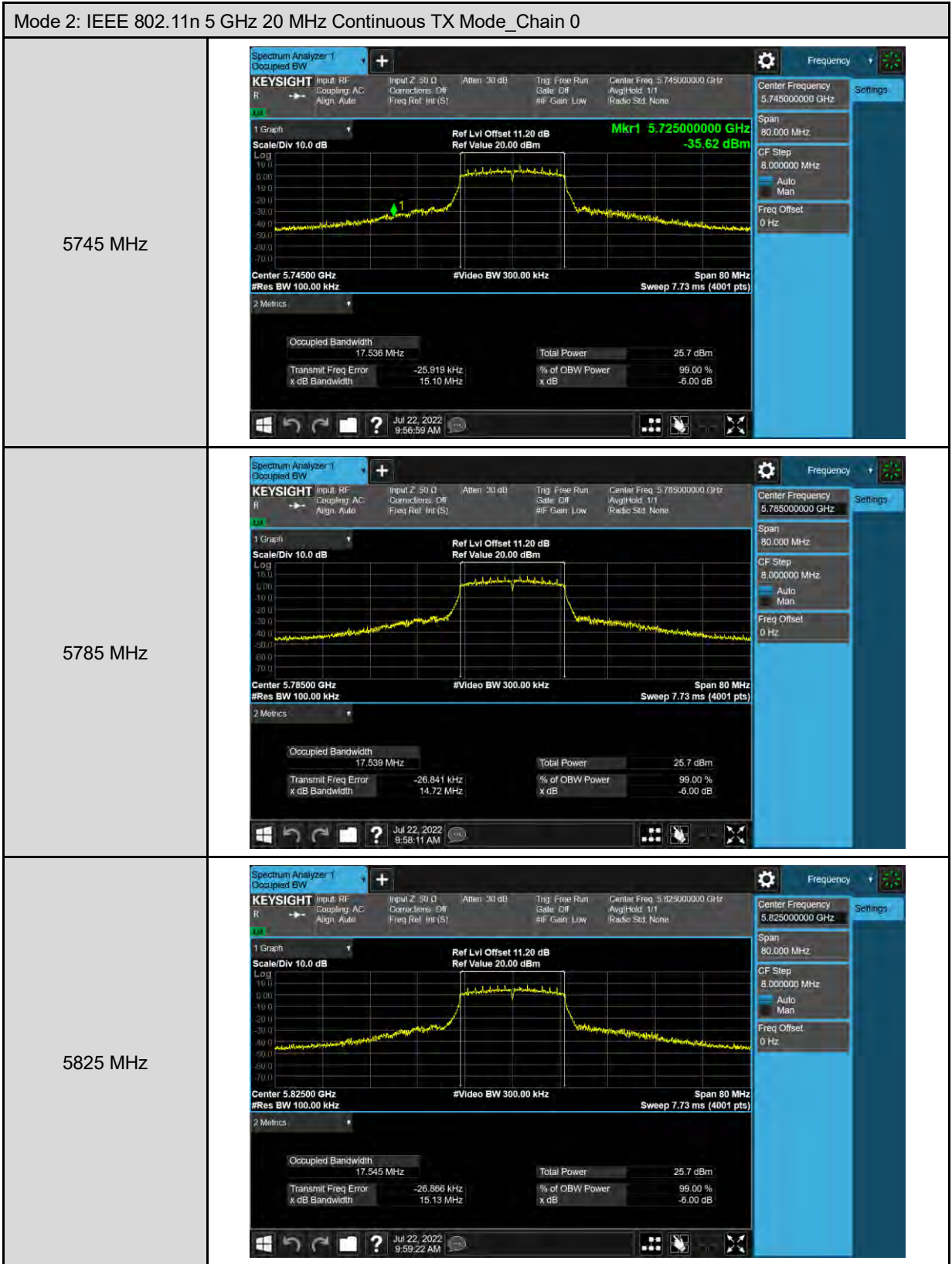

Maximum Power Spectral Density Measurement

Power spectral density					
Test Mode	Frequency (MHz)	Chain 0			
		Measurement (dBm/MHz)	Duty Factor (dB)	Calculated (dBm/MHz)	Limit (dBm/MHz)
Mode 1	5180	7.479	0.411	7.890	≤ 11.00
	5200	9.624	0.411	10.035	≤ 11.00
	5240	9.783	0.411	10.194	≤ 11.00
Mode 2	5180	7.199	0.468	7.667	≤ 11.00
	5200	8.231	0.468	8.699	≤ 11.00
	5240	8.825	0.468	9.293	≤ 11.00

Note: Method SA-2, Power density = measured result + 10 log(1/duty cycle) + Conversion ratio = measured result + duty factor.

Power spectral density					
Test Mode	Frequency (MHz)	Chain 0			
		Measurement (dBm/100 kHz)	Duty Factor (dB)	Calculated (dBm/500 kHz)	Limit (dBm/500 kHz)
Mode 1	5745	0.150	0.411	7.551	≤ 30.00
	5785	0.070	0.411	7.471	≤ 30.00
	5825	0.289	0.411	7.690	≤ 30.00
Mode 2	5745	-0.565	0.468	6.892	≤ 30.00
	5785	-0.766	0.468	6.691	≤ 30.00
	5825	-0.773	0.468	6.684	≤ 30.00

Note: Method SA-2, Power density = measured result + 10 log(1/duty cycle) + Conversion ratio = measured result + duty factor.

Conversion ratio = 10*Log(500 k/100 k)

Test Graphs

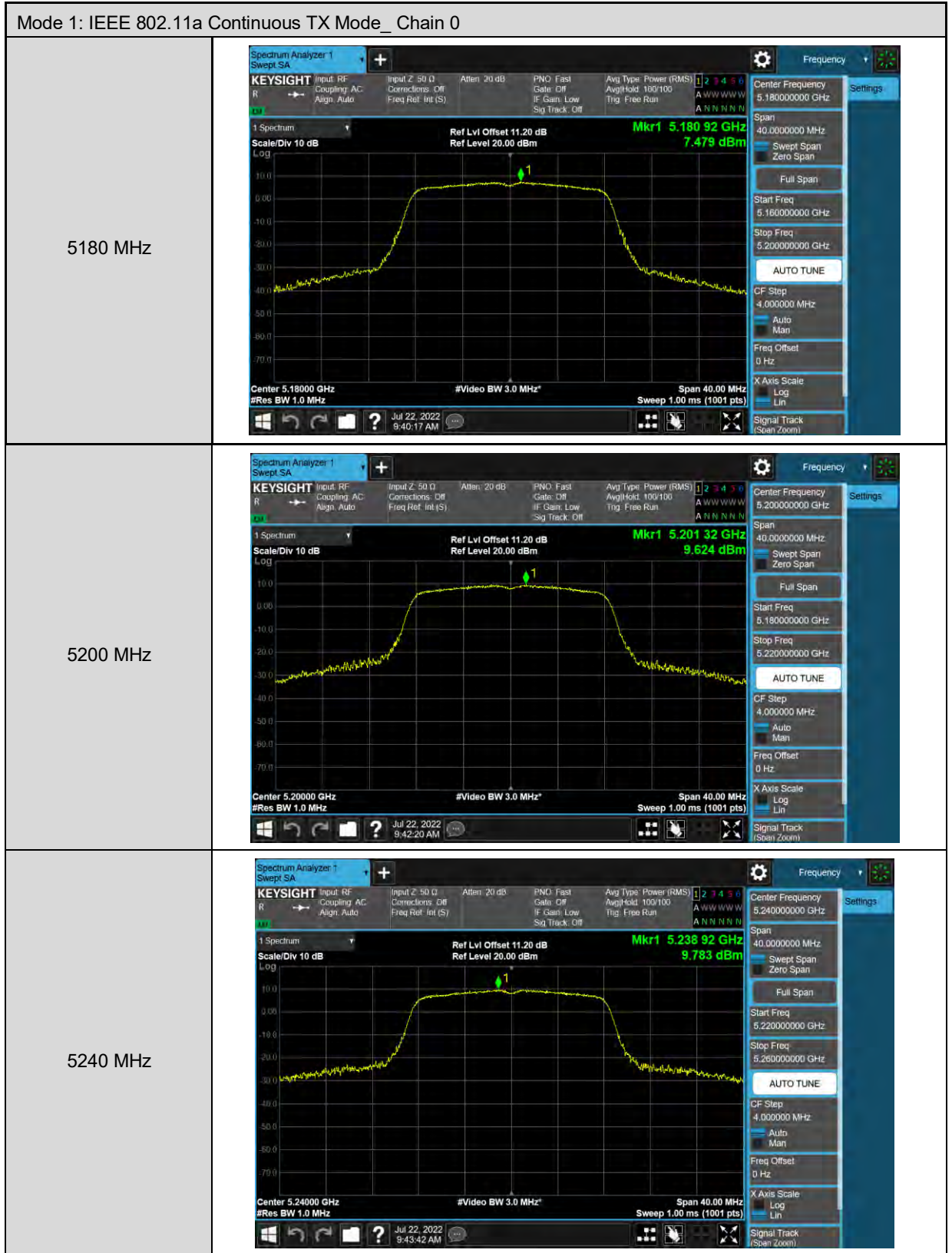

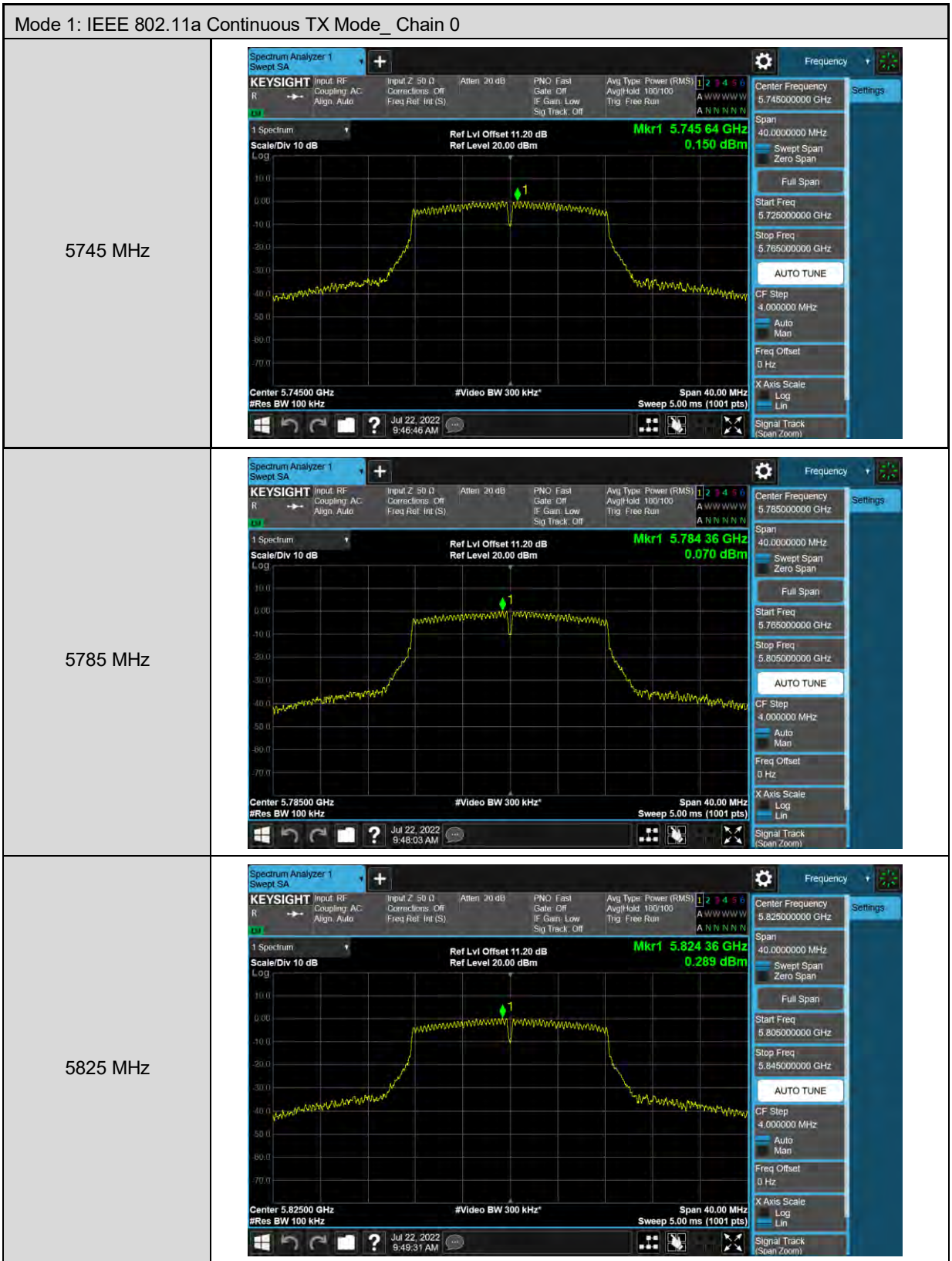

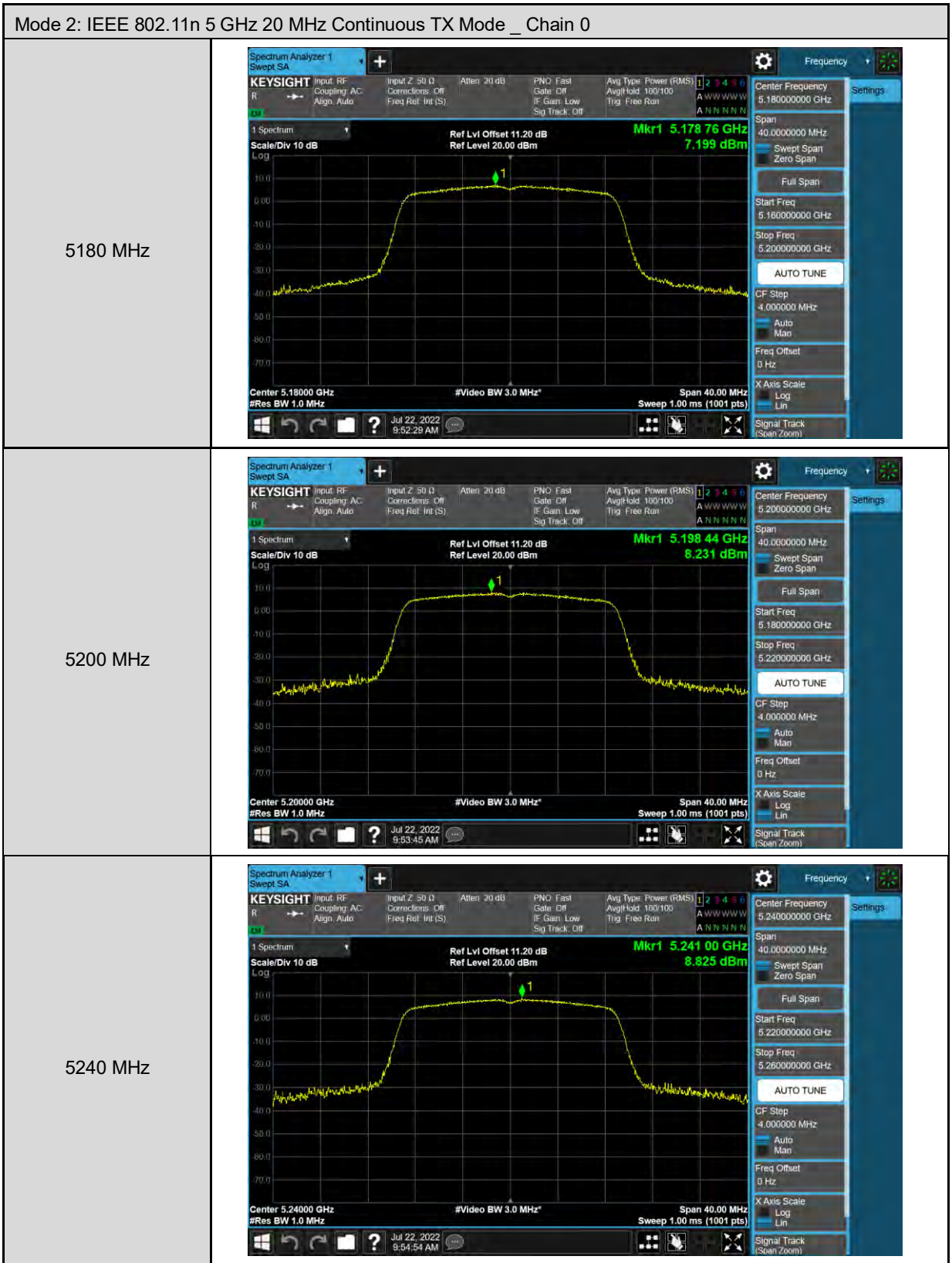



---END---