

RF Test Report

Applicant : AcSiP Technology Corporation

Product Name : Wi-Fi 6 (1x1) 802.11a/b/g/n/ac/ax + BT5.2 Combo IoT Module

Trade Name : AcSiP

Model Number : AI7933CLD

Applicable Standard : FCC 47 CFR PART 15 SUBPART C
ANSI C63.10:2013

Received Date : Jul. 08, 2022

Test Period : Jul. 20 ~ Jul. 23, 2022

Issued Date : Aug. 09, 2022

Issued by

A Test Lab Techno Corp.
No. 140-1, Changan Street, Bade District,
Taoyuan City 334025, Taiwan (R.O.C.)
Tel : +886-3-2710188 / Fax : +886-3-2710190



Taiwan Accreditation Foundation accreditation number: 1330
Frequency Range : 9 kHz to 40 GHz
Test Firm MRA designation number: TW0010

Note:

- 1.The test results are valid only for samples provided by customers and under the test conditions described in this report.
- 2.This report shall not be reproduced except in full, without the written approval of A Test Lab Technology Corporation.
- 3.The relevant information is provided by customers in this test report. According to the correctness, appropriateness or completeness of the information provided by the customer, if there is any doubt or error in the information which affects the validity of the test results, the laboratory does not take the responsibility.

Revision History

Rev.	Issued Date	Revisions	Revised By
00	Aug. 04, 2022	Initial Issue	Abby Huang
01	Aug. 09, 2022	Update chapter 3.4 (P.11)	Abby Huang

Verification of Compliance

Applicant : AcSiP Technology Corporation

Product Name : Wi-Fi 6 (1x1) 802.11a/b/g/n/ac/ax + BT5.2 Combo IoT Module

Trade Name : AcSiP

Model Number : AI7933CLD

FCC ID : 2ADWC-AI7933CLD

Applicable Standard : FCC 47 CFR PART 15 SUBPART C
ANSI C63.10:2013

Test Result : Complied

Performing Lab. : A Test Lab Techno Corp.
No. 140-1, Changan Street, Bade District,
Taoyuan City 334025, Taiwan (R.O.C.)
Tel : +886-3-2710188 / Fax : +886-3-2710190
Taiwan Accreditation Foundation accreditation number: 1330



A Test Lab Techno Corp. tested the above equipment in accordance with the requirements set forth in the above standards. All indications of Pass/Fail in this report are opinions expressed by A Test Lab Techno Corp. based on interpretations and/or observations of test results. The test results show that the equipment tested is capable of demonstrating compliance with the requirements as documented in this report.

Approved By : _____
(Kai Yu Yang)

TABLE OF CONTENTS

1	General Information	5
1.1.	Summary of Test Result	5
1.2.	Measurement Uncertainty	6
2	EUT Description	7
3	Test Methodology	8
3.1.	Mode of Operation	8
3.2.	EUT Test Step	8
3.3.	Configuration of Test System Details	9
3.4.	Test Instruments	10
3.5.	Test Site Environment	13
4	Measurement Procedure	14
4.1.	AC Power Line Conducted Emission Measurement	14
4.2.	Radiated Emission Measurement	16
4.3.	Maximum Conducted Output Power Measurement	20
4.4.	6 dB RF Bandwidth Measurement	21
4.5.	Maximum Power Density Measurement	22
4.6.	Out of Band Conducted Emissions Measurement	23
4.7.	Antenna Measurement	23
5	Test Results	24
5.1.	Conducted Emission	24
5.2.	Conducted Test Results	26
5.3.	Radiated Emission Measurement	41

Appendix A. Test Setup Photographs

1 General Information

1.1. Summary of Test Result

Standard	Item	Result	Remark
15.207	AC Power Conducted Emission	PASS	-----
15.247(d)	Transmitter Radiated Emissions	PASS	-----
15.247(b)(3)	Max. Output Power	PASS	-----
15.247(a)(2)	6 dB RF Bandwidth	PASS	-----
15.247(e)	Maximum Power Spectral Density	PASS	-----
15.247(d)	Out of Band Conducted Spurious Emission	PASS	-----
15.203	Antenna Requirement	PASS	-----

Decision Rule

- Uncertainty is not included.
- Uncertainty is included.

Standard	Description
CFR47, Part 15, Subpart C	Intentional Radiators
ANSI C63. 10: 2013	American National Standard of Procedures for Compliance Testing of Unlicensed Wireless Devices
KDB 558074 D01 15.247 Meas Guidance v05r02	GUIDANCE FOR COMPLIANCE MEASUREMENTS ON DIGITAL TRANSMISSION SYSTEM, FREQUENCY HOPPING SPREAD SPECTRUM SYSTEM, AND HYBRID SYSTEM DEVICES OPERATING UNDER SECTION 15.247 OF THE FCC RULES

1.2. Measurement Uncertainty

Test Item	Frequency Range	Uncertainty
Conducted Emission	150 kHz ~ 30 MHz	2.7 dB
Radiated Emission	9 kHz ~ 30 MHz	2.2 dB
	30 MHz ~ 1000 MHz	5.1 dB
	1000 MHz ~ 18000 MHz	5.2 dB
	18000 MHz ~ 26500 MHz	4.6 dB
	26500 MHz ~ 40000 MHz	4.6 dB
Conducted Output Power	1.1 dB	
RF Bandwidth	4.7 %	
Power Spectral Density	1.1 dB	

2 EUT Description

Applicant	AcSiP Technology Corporation 9F, No. 242, Bo'ai St., Shulin Dist 23805 New Taipei Taiwan			
Product Name	Wi-Fi 6 (1x1) 802.11a/b/g/n/ac/ax + BT5.2 Combo IoT Module			
Trade Name	AcSiP			
Model No.	AI7933CLD			
FCC ID	2ADWC-AI7933CLD			
Frequency Range	2402 ~ 2480 MHz			
Modulation Type	GFSK			
Operate Temp. Range	0 ~ +60 °C			
EUT Power Rating	DC 5 V			
Antenna information	Antenna	Model No	Type	Max. Gain (dBi)
	Antenna-1	IAHA202205004	PCB Dipole Antenna	1.94
	Antenna-2	IAHA202205005	FPC Dipole Antenna	2.76
RF Output Power	LE, GFSK:	0.02239 W		
	2LE, GFSK:	0.02871 W		
	BLR C2, GFSK:	0.02270 W		
	BLR C8, GFSK:	0.02291 W		

3 Test Methodology

3.1. Mode of Operation

Decision of Test ATL has verified the construction and function in typical operation. All the test modes were carried out with the EUT in normal operation, which was shown in this test report and defined as:

Pre-Test Mode
Mode 1: LE, GFSK Continuous TX Mode
Mode 2: 2LE, GFSK Continuous TX Mode
Mode 3: BLR C2, GFSK Continuous TX Mode
Mode 4: BLR C8, GFSK Continuous TX Mode

Final-Test Mode
Mode 2: 2LE, GFSK Continuous TX Mode
Mode 4: BLR C8, GFSK Continuous TX Mode

Software used to control the EUT for staying in continuous transmitting mode was programmed.

After verification, all tests were carried out with the worst case test modes.

By preliminary testing and verifying three axis (X, Y and Z) position of EUT transmitted status, it was found that "X axis" position was the worst, then the final test was executed the worst condition and test data were recorded in this report.

3.2. EUT Test Step

1	Setup the EUT shown on "Configuration of Test System Details".
2	Turn on the power of all equipment.
3	Turn on TX function.
4	EUT run test program.

3.3. Configuration of Test System Details

Radiated Emission & Conduction Emission

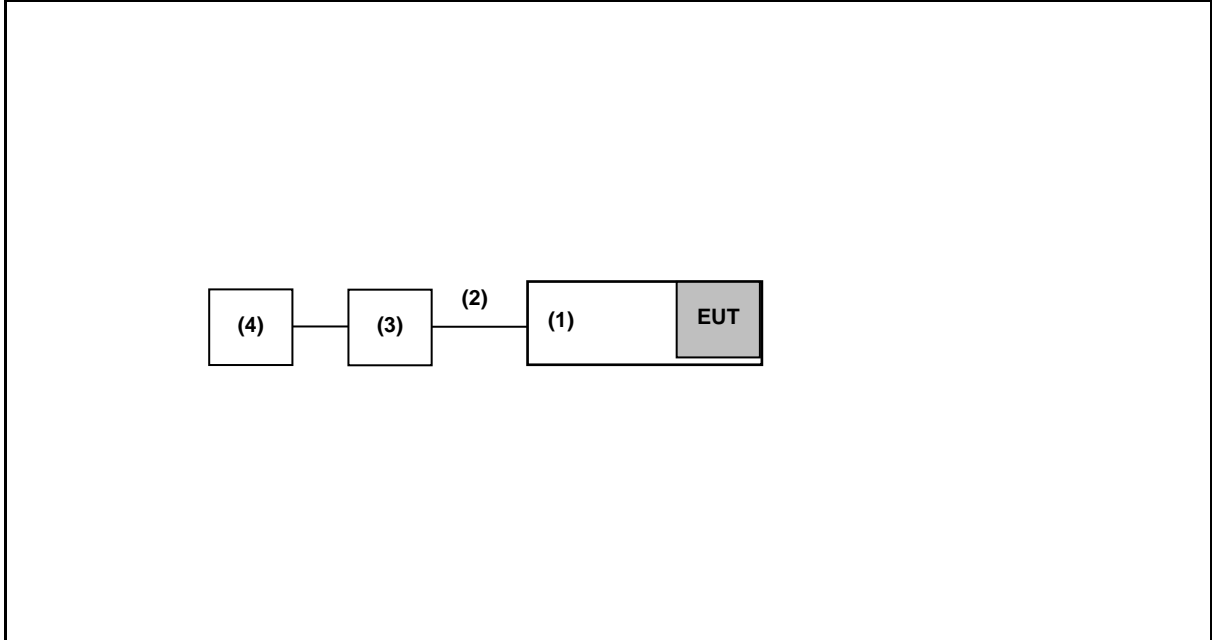

Devices Description					
	Product	Manufacturer	Model Number	Serial Number	Power Cord
(1)	Fixture	AcSiP	EK-AI7933CLD	---	---
(2)	USB Cable	LG	EAD63769703	---	---
(3)	Notebook	acer	N19C1	---	---
(4)	AC Adapter	chiicony	A18-045N2A	---	Non-Shielded, 1.5 m

3.4. Test Instruments

For Conducted

Test Period: Jul. 21, 2022

Testing Engineer: Brian Lin

Use	Equipment	Manufacturer	Model Number	Serial Number	Cal. Date	Cal. Period
<input type="checkbox"/>	Power Sensor	Anritsu	MA2411B	1126022	Sep. 03, 2021	1 year
<input type="checkbox"/>	Power Meter	Anritsu	ML2495A	1135009	Sep. 03, 2021	1 year
<input checked="" type="checkbox"/>	Power Sensor	Agilent	N1921A	MY45241957	Dec. 06, 2021	1 year
<input checked="" type="checkbox"/>	Power Meter	Agilent	N1911A	MY45101619	Dec. 06, 2021	1 year
<input checked="" type="checkbox"/>	Spectrum Analyzer (10 Hz~26.5 GHz)	Keysight	N9010B	MY59071418	Mar. 16, 2022	1 year
<input type="checkbox"/>	Spectrum Analyzer (9 kHz~26.5 GHz)	Agilent	N9010A	MY48030518	Jul. 23, 2021	1 year
<input type="checkbox"/>	Spectrum Analyzer (20 Hz~26.5 GHz)	Agilent	N9020A	US47520902	Sep. 09, 2021	1 year
<input type="checkbox"/>	Spectrum Analyzer (3 Hz~50 GHz)	Agilent	N9030A	MY53120541	Jan. 05, 2022	1 year
<input type="checkbox"/>	Temperature & Humidity Chamber	TAICHY	MHU-225LA	980729	Mar. 28, 2022	1 year
<input type="checkbox"/>	Signal Generator	Keysight	N5182B	MY53052569	Apr. 16, 2022	1 year
<input type="checkbox"/>	Signal Generator	Keysight	N5182BX07	MY59360221	Apr. 16, 2022	1 year
<input type="checkbox"/>	Bluetooth Tester	R&S	CBT	100350	Mar. 17, 2021	2 years
<input type="checkbox"/>	Wireless Connectivity Tester	R&S	CMW270	102208	Jun. 02, 2021	1 year
<input type="checkbox"/>	Power Supply	KEITHLEY	2303	4045290	Jan. 19, 2022	1 year
<input type="checkbox"/>	RF Communication Test Set	HP	8920A	3344A03297	Aug. 10, 2021	1 year

For Conducted Emission

Test Period: Jul. 23, 2022

Testing Engineer: Chi Chang

Use	Equipment	Manufacturer	Model Number	Serial Number	Cal. Date	Cal. Period
<input checked="" type="checkbox"/>	Test Receiver	R&S	ESCI	100367	May 19, 2022	1 year
<input type="checkbox"/>	Test Receiver	R&S	ESCI	100722	Nov. 02, 2021	1 year
<input type="checkbox"/>	Test Receiver	R&S	ESCI	101000	Nov. 26, 2021	1 year
<input checked="" type="checkbox"/>	LISN	R&S	ENV216	101040	Apr. 06, 2022	1 year
<input type="checkbox"/>	LISN	R&S	ENV216	101041	Apr. 15, 2022	1 year
<input checked="" type="checkbox"/>	RF Cable	Woken	00100D1380194M	TE-02-03	May 27, 2022	1 year
<input checked="" type="checkbox"/>	Software	EZ EMC	1.1.4.3	N/A	N.C.R.	---

Note: N.C.R. = No Calibration Request.

For Radiated Emissions

Test Period: Jul. 20, 2022

Testing Engineer: Hung Chou, Marc Yeh

Radiation test sites		Semi Anechoic Room				
Use	Equipment	Manufacturer	Model Number	Serial Number	Cal. Date	Cal. Period
<input type="checkbox"/>	Spectrum Analyzer (10 Hz~44 GHz)	Keysight	N9010A	MY52221312	Jan. 13, 2022	1 year
<input type="checkbox"/>	Spectrum Analyzer (3 Hz~50 GHz)	Agilent	N9030A	MY53120541	Jan. 05, 2022	1 year
<input checked="" type="checkbox"/>	Spectrum Analyzer (2 Hz~50 GHz)	Keysight	N9030B	MY57143537	Apr. 14, 2022	1 year
<input type="checkbox"/>	Spectrum Analyzer (10 Hz~44 GHz)	Keysight	N9020B	MY60112363	Feb. 27, 2022	1 year
<input checked="" type="checkbox"/>	Amplifier (1 GHz~26.5 GHz)	Agilent	8449B	3008A02237	Oct. 21, 2021	1 year
<input checked="" type="checkbox"/>	Amplifier (100 kHz~1.3 GHz)	Agilent	8447D	2944A11119	Jan. 14, 2022	1 year
<input type="checkbox"/>	Amplifier (100 kHz~1.3 GHz)	Agilent	8447D	2944A10961	Jul. 06, 2021	1 year
<input type="checkbox"/>	Broadband Amplifier (100 kHz~1 GHz)	Titan	T0910E00014330A1F	001	Jul. 23, 2021	1 year
<input type="checkbox"/>	Amplifier (1 GHz~26.5 GHz)	Agilent	8449B	3008A02237	Oct. 21, 2021	1 year
<input type="checkbox"/>	Broadband Amplifier (1 GHz~26.5 GHz)	Titan	T0912E01263025A1F	002	Jul. 26, 2021	1 year
<input type="checkbox"/>	Preamplifier (26.5 GHz~40 GHz)	EMCI	EMC2654045	980028	Aug. 19, 2021	1 year
<input checked="" type="checkbox"/>	Loop Antenna (9 kHz~30 MHz)	COM-POWER CORPORATION	AL-130	121014	Mar. 28, 2022	1 year
<input type="checkbox"/>	Active Loop Antenna (9 kHz~30 MHz)	Schwarzbeck Mess-Elektronik	FMZB 1513-60	1513-60-031	Feb. 17, 2022	1 year
<input type="checkbox"/>	Trilog Broadband Antenna (30 kHz~1 GHz)	Schwarzbeck Mess-Elektronik	VULB9168	01146	Jul. 19, 2021	1 year
<input checked="" type="checkbox"/>	Trilog Broadband Antenna (30 kHz~1 GHz)	Schwarzbeck Mess-Elektronik	VULB9168	416	Nov. 17, 2021	1 year
<input type="checkbox"/>	Broadband Horn Antenna (1 GHz~18 GHz)	Schwarzbeck Mess-Elektronik	9120D	02207	Jul. 09, 2021	1 year
<input checked="" type="checkbox"/>	Broadband Horn Antenna (1 GHz~18 GHz)	Schwarzbeck Mess-Elektronik	9120D	9120D-550	Aug. 24, 2021	1 year
<input checked="" type="checkbox"/>	Broadband Horn Antenna (18 GHz~40 GHz)	Schwarzbeck Mess-Elektronik	9170	9170-320	Aug. 24, 2021	1 year
<input type="checkbox"/>	Horn Antenna (18 GHz~40 GHz)	ETS	3116	00086467	Dec. 03, 2021	1 year

Note: N.C.R. = No Calibration Request.

For Radiated Emissions

Test Period: Jul. 20, 2022

Testing Engineer: Hung Chou, Marc Yeh

Radiation test sites		Semi Anechoic Room				
Use	Equipment	Manufacturer	Model Number	Serial Number	Cal. Date	Cal. Period
<input type="checkbox"/>	RF Cable	EMCI	EMC104-N-N-6000	TE01-1	Feb. 18, 2022	1 year
<input type="checkbox"/>	Microwave Cable	EMCI	EMC104-SM-SM-13000	170814	Feb. 18, 2022	1 year
<input type="checkbox"/>	Microwave Cable	EMCI	EMC102-KM-KM-14000	151001	Feb. 18, 2022	1 year
<input checked="" type="checkbox"/>	Coaxial Cable	Titan	T0710AT327A10A100	J11005	Aug. 06, 2021	1 year
<input checked="" type="checkbox"/>	Coaxial Cable	Titan	T0710AT327A10A900	J11004	Aug. 06, 2021	1 year
<input checked="" type="checkbox"/>	Coaxial Cable	Titan	CFD400NL-LW	001	Aug. 06, 2021	1 year
<input type="checkbox"/>	Bluetooth Tester	R&S	CBT	100350	Mar. 17, 2021	2 years
<input type="checkbox"/>	Wireless Connectivity Tester	R&S	CMW270	102208	Jun. 02, 2021	1 year
<input type="checkbox"/>	Power Supply	KEITHLEY	2303	4045290	Jan. 19, 2022	1 year
<input checked="" type="checkbox"/>	Software	EZ EMC	1.1.4.4	N/A	N.C.R.	---

Note: N.C.R. = No Calibration Request.

3.5. Test Site Environment

Items	Required (IEC 60068-1)	Actual
Temperature (°C)	15-35	20-30
Humidity (%RH)	25-75	45-75

4 Measurement Procedure

4.1. AC Power Line Conducted Emission Measurement

■ Limit

Frequency (MHz)	Quasi-peak	Average
0.15 - 0.5	66 to 56	56 to 46
0.50 - 5.0	56	46
5.0 - 30.0	60	50

■ Test Setup

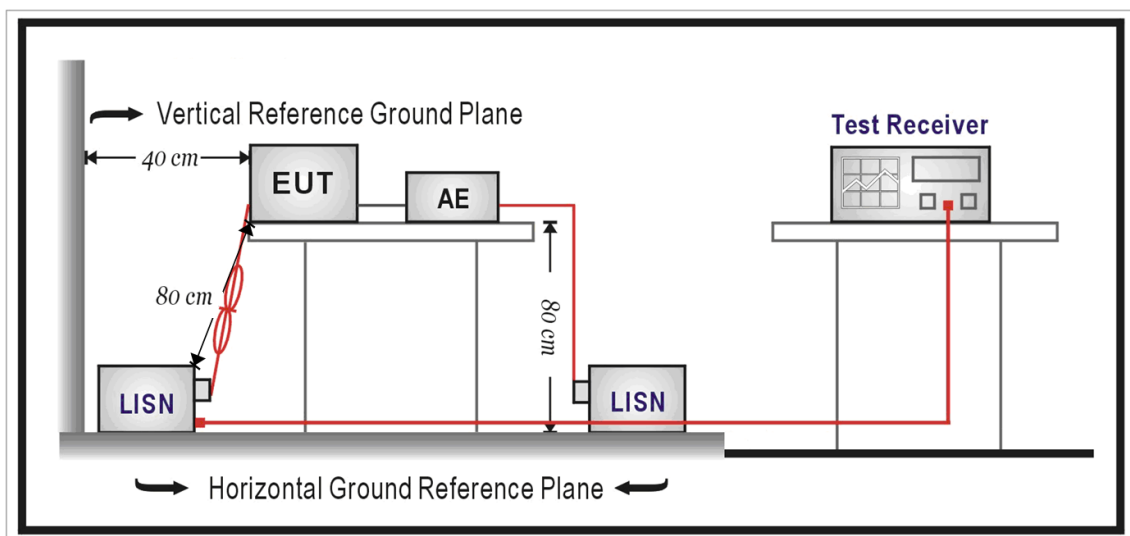

■ Test Procedure

The EUT and simulators are connected to the main power through a line impedance stabilization network (L.I.S.N.). This provides a $50 \Omega // 50 \mu\text{H}$ coupling impedance for the measuring equipment. The peripheral devices are also connected to the main power through a LISN that provides a $50 \Omega // 50 \mu\text{H}$ coupling impedance with 50 ohm termination.

Tabletop device shall be placed on a non-conducting platform, of nominal size 1 m by 1.5 m, raised 80 cm above the reference ground plane. The wall of screened room shall be located 40 cm to the rear of the EUT. Other surfaces of tabletop or floor standing EUT shall be at least 80 cm from any other ground conducting surface including one or more LISNs. For floor-standing device shall be placed under the EUT with a 12 mm insulating material.

Conducted emissions were investigated over the frequency range from 0.15 MHz to 30 MHz using a resolution bandwidth of 9 kHz. The equipment under test (EUT) shall be meet the limits in section 4.1, as applicable, including the average limit and the quasi-peak limit when using respectively, an average detector and quasi-peak detector measured in accordance with the methods described of related standard. When all of peak value were complied with quasi-peak and average limit from 150 kHz to 30 MHz then quasi-peak and average measurement was unnecessary.

The AMN shall be placed 0.8 m from the boundary of the unit under test and bonded to a ground reference plane for AMNs mounted on top of the ground reference plane. This distance is between the closest points of the AMN and the EUT. All other units of the EUT and associated equipment shall be at least 0.8 m from the AMN. If the mains power cable is longer than 1 m then the cable shall be folded back and forth at the centre of the lead to form a bundle no longer than 0.4 m. All of interconnecting cables that hang closer than 40 cm to the ground plane shall be folded back and forth in the center forming a bundle 30 cm to 40 cm long. All of EUT and AE shall be separate place more than 0.1 m. All 50 Ω ports of the LISN shall be resistively terminated into 50 Ω loads when not connected to the measuring instrument.

If the reading of the measuring receiver shows fluctuations close to the limit, the reading shall be observed for at least 15 s at each measurement frequency; the higher reading shall be recorded with the exception of any brief isolated high reading which shall be ignored.

4.2. Radiated Emission Measurement

■ Limit

According to §15.209(a), except as provided elsewhere in this subpart, the emissions from an intentional radiator shall not exceed the field strength levels specified in the following table:

Frequency (MHz)	Field Strength ($\mu\text{V}/\text{m}$ at meter)	Measurement Distance (meters)
0.009 – 0.490	$2400 / F$ (kHz)	300
0.490 – 1.705	$24000 / F$ (kHz)	30
1.705 – 30.0	30	30
30 - 88	100**	3
88-216	150**	3
216-960	200**	3
Above 960	500	3

** Except as provided in paragraph (g), fundamental emissions from intentional radiators operating under this Section shall not be located in the frequency bands 54-72 MHz, 76-88 MHz, 174-216 MHz or 470-806 MHz. However, operation within these frequency bands is permitted under other sections of this Part, e.g., Sections 15.231 and 15.241.

■ Setup

9 kHz ~ 30 MHz

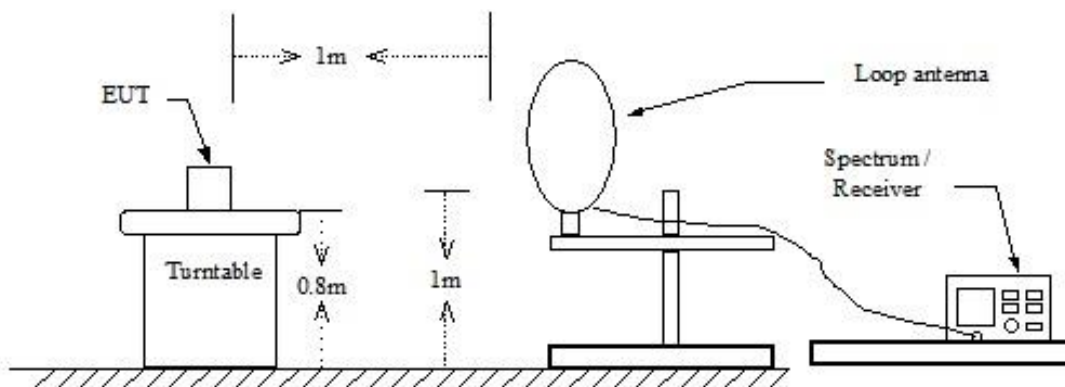

Below 1 GHz

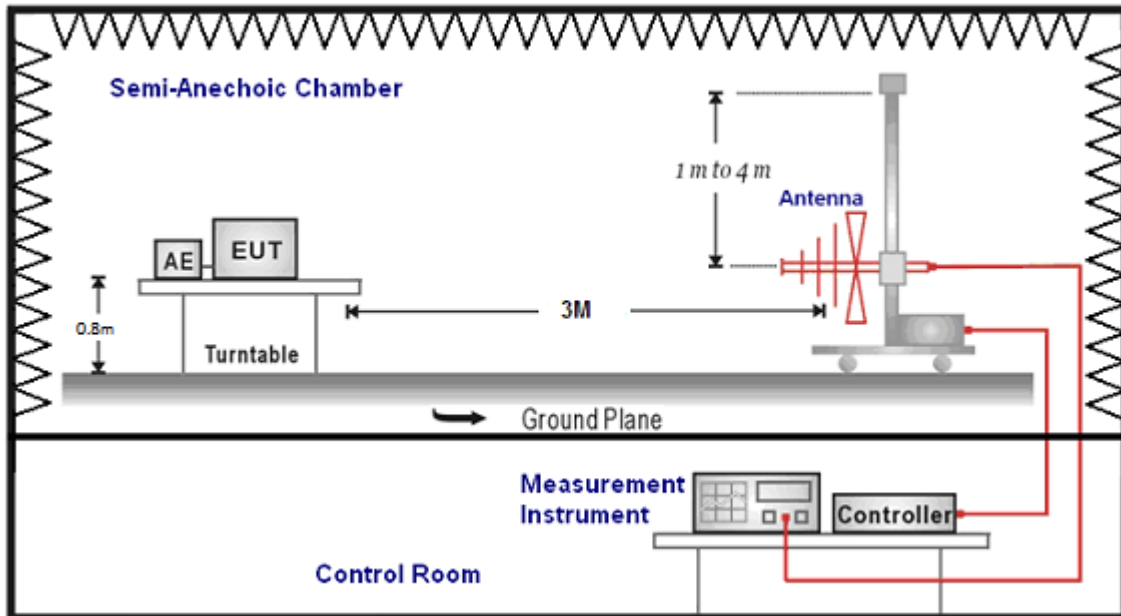

Above 1 GHz

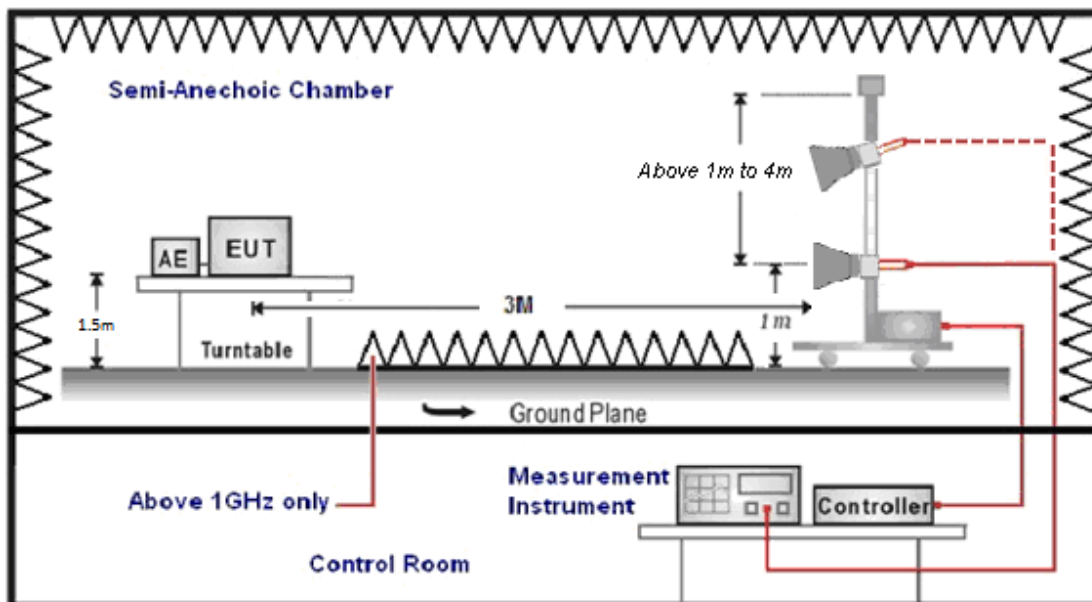

■ Test Procedure

Final radiation measurements were made on a three-meter, Semi Anechoic Chamber. The EUT system was placed on a nonconductive turntable which is 0.8 or 1.5 meters height, top surface 1.0 x 1.5 meter. The spectrum was examined from 250 MHz to 2.5 GHz in order to cover the whole spectrum below 10th harmonic which could generate from the EUT. During the test, EUT was set to transmit continuously & Measurements spectrum range from 9 kHz to 26.5 GHz is investigated.

For measurements below 1 GHz the resolution bandwidth is set to 100 kHz for peak detection measurements or 120 kHz for quasi-peak detection measurements. Peak detection is used unless otherwise noted as quasi-peak.

For measurements above 1 GHz the resolution bandwidth is set to 1 MHz, and then the video bandwidth is set to 3 MHz for peak measurements and 10 Hz for average measurements when Duty cycle >0.98 / $1/T$ for average measurements when Duty cycle <0.98 . A nonconductive material surrounded the EUT to supporting the EUT for standing on three orthogonal planes. At each condition, the EUT was rotated 360 degrees, and the antenna was raised and lowered from one to four meters to find the maximum emission levels. Measurements were taken using both horizontal and vertical antenna polarization.

SCHWARZBECK MESS-ELEKTRONIK Biconilog Antenna at 3 Meter and the SCHWARZBECK Double Ridged Guide Antenna was used in frequencies 1 –26.5 GHz at a distance of 3 meter. The antenna at an angle toward the source of the emission. All test results were extrapolated to equivalent signal at 3 meters utilizing an inverse linear distance extrapolation Factor (20 dB/decade).

For testing above 1 GHz, the emission level of the EUT in peak mode was 20 dB lower than average limit (that means the emission level in peak mode also complies with the limit in average mode), then testing will be stopped and peak values of EUT will be reported, otherwise, the emissions will be measured in average mode again and reported.

Appropriate preamplifiers were used for improving sensitivity and precautions were taken to avoid overloading or desensitizing the spectrum analyzer. No post – detector video filters were used in the test.

The spectrum analyzer's 6 dB bandwidth was set to 1 MHz, and the analyzer was operated in the peak detection mode, for frequencies both below and up 1 GHz. The average levels were obtained by subtracting the duty cycle correction factor from the peak readings.

The following procedures were used to convert the emission levels measured in decibels referenced to 1 microvolt (dBuV) into field intensity in micro volts pre meter ($\mu\text{V}/\text{m}$).

The actual field intensity in decibels referenced to 1 microvolt in to field intensity in micro volts per meter (dBuV/m).

The actual field intensity in referenced to 1 microvolt per meter (dBuV/m) is determined by algebraically adding the measured reading in dBuV, the antenna factor (dB), and cable loss (dB) and Subtracting the gain of preamplifier (dB) is auto calculate in spectrum analyzer.

$$(1) \text{ Amplitude (dBuV/m) = FI (dBuV) +AF (dBuV) +CL (dBuV)-Gain (dB)}$$

FI= Reading of the field intensity.

AF= Antenna factor.

CL= Cable loss.

P.S Amplitude is auto calculate in spectrum analyzer.

$$(2) \text{ Actual Amplitude (dBuV/m) = Amplitude (dBuV)-Dis(dB)}$$

The FCC specified emission limits were calculated according the EUT operating frequency and by following linear interpolation equations:

(a) For fundamental frequency : Transmitter Output < +30 dBm

(b) For spurious frequency : Spurious emission limits = fundamental emission limit /10

Data of measurement within this frequency range without mark in the table above means the reading of emissions are attenuated more than 20 dB below the permissible limits or the field strength is too small to be measured.

4.3. Maximum Conducted Output Power Measurement

- **Limit**

For systems using digital modulation in the 2400-2483.5 MHz, the limit for peak output power is 30 dBm.

- **Test Setup**

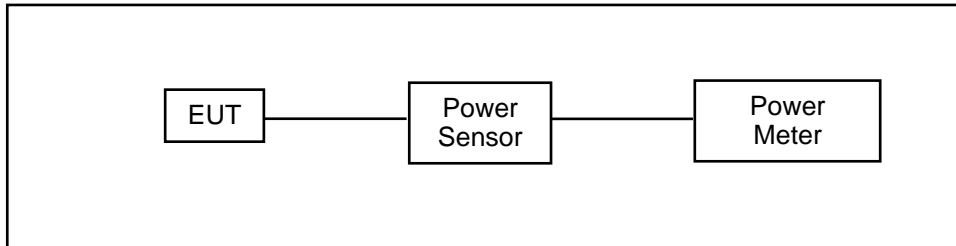

- **Test Procedure**

The testing follows the Measurement Procedure of ANSI C63.10:2013 section 11.9.2.3.2 Method AVGPM.

The tests below are run with the EUT's transmitter set at high power in TX mode. The EUT is needed to force selection of output power level and channel number. While testing, EUT was set to transmit continuously. Remove the Subjective device's antenna and connect the RF output port to power sensor..

4.4. 6 dB RF Bandwidth Measurement

■ Limit

6 dB RF Bandwidth: Systems using digital modulation techniques may operate in the 2400–2483.5 MHz bands. The minimum 6 dB band-width shall be at least 500 kHz.

99 % Occupied Bandwidth: N/A

■ Test Setup

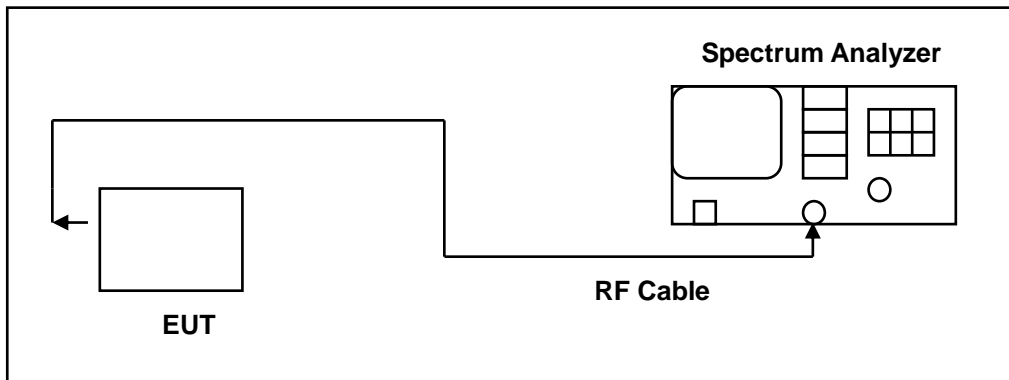

■ Test Procedure

The EUT tested to DTS test procedure of ANSI C63.10:2013 section 11.8.2 option2 for compliance to FCC 47CFR 15.247 requirements.

6 dB RF Bandwidth: The antenna port of the EUT was connected to the input of a spectrum analyzer. Analyzer RBW was set to 100 kHz. For each RF output channel investigated, the spectrum analyzer center frequency was set to the channel carrier. A peak output reading was taken, a DISPLAY line was drawn 6 dB lower than peak level. The 6 dB bandwidth was determined from where the channel output spectrum intersected the display line.

The test was performed at 3 channels (Channel low, middle, high)

4.5. Maximum Power Density Measurement

■ Limit

For digitally modulated systems, the power spectral density conducted from the intentional radiator to the antenna shall not be greater than 8 dBm in any 3 kHz band during any time interval of continuous transmission.

■ Test Setup

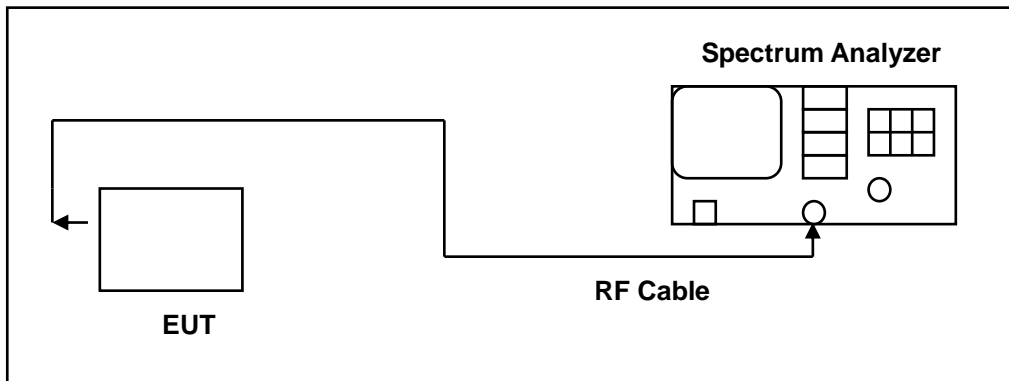

■ Test Procedure

The EUT tested to DTS test procedure of ANSI C63.10:2013 section 11.10.2 Method PKPSD.

1. Set analyzer center frequency to DTS channel center frequency.
2. Set the span to 1.5 times the DTS bandwidth.
3. Set the RBW to: $3 \text{ kHz} \leq \text{RBW} \leq 100 \text{ kHz}$.
4. Set the VBW $\geq 3 \times \text{RBW}$.
5. Detector = peak.
6. Sweep time = auto couple.
7. Trace mode = max hold.
8. Allow trace to fully stabilize.
9. Use the peak marker function to determine the maximum amplitude level within the RBW.
10. If measured value exceeds limit, reduce RBW (no less than 3 kHz) and repeat.

4.6. Out of Band Conducted Emissions Measurement

■ Limit

In any 100 kHz bandwidth outside the frequency band in which the spread spectrum or digitally modulated intentional radiator is operating, the radio frequency power that is produced by the intentional radiator shall be at least 20 dB below that in the 100 kHz bandwidth within the band that contains the highest level of the desired power

■ Test Setup

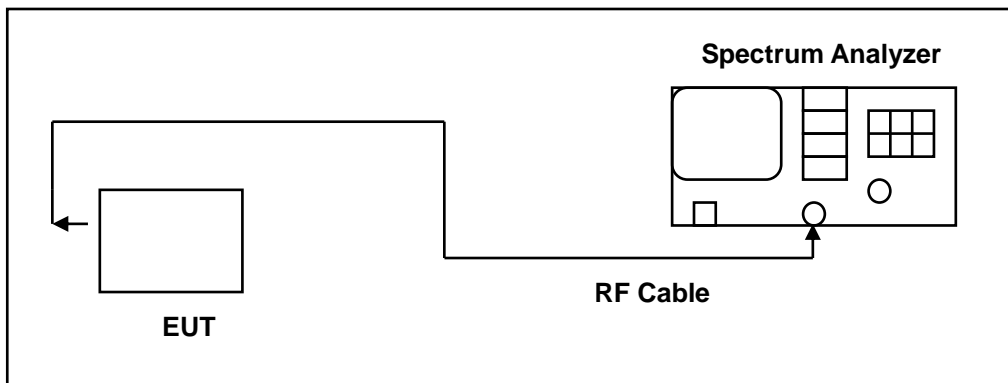

■ Test Procedure

In any 100 kHz bandwidth outside the EUT pass band, the RF power produced by the modulation products of the spreading sequence, the information sequence, and the carrier frequency shall be at least 20 dB below that of the maximum in-band 100 kHz emission, antenna output of the EUT was coupled directly to spectrum analyzer; if an external attenuator and/or cable was used, these losses are compensated for with the analyzer OFFSET function.

All other types of emissions from the EUT shall meet the general limits for radiated frequencies outside the pass band.

The test was performed at 3 channels.

4.7. Antenna Measurement

■ Limit

For intentional device, according to 15.203, an intentional radiator shall be designed to ensure that no antenna other than that furnished by the responsible party shall be used with the device.

And According to 15.247 (b), if transmitting antennas of directional gain greater than 6 dBi are used, the power shall be reduced by the amount in dB that the directional gain of the antenna exceeds 6 dBi.

■ Antenna Connector Construction

See section 2 – antenna information.

5 Test Results

5.1. Conducted Emission

Standard:	FCC Part 15.247	Line:	L1
Test item:	Conducted Emission	Power:	AC 120 V/60 Hz
Mode:	Mode 1		
Description:			

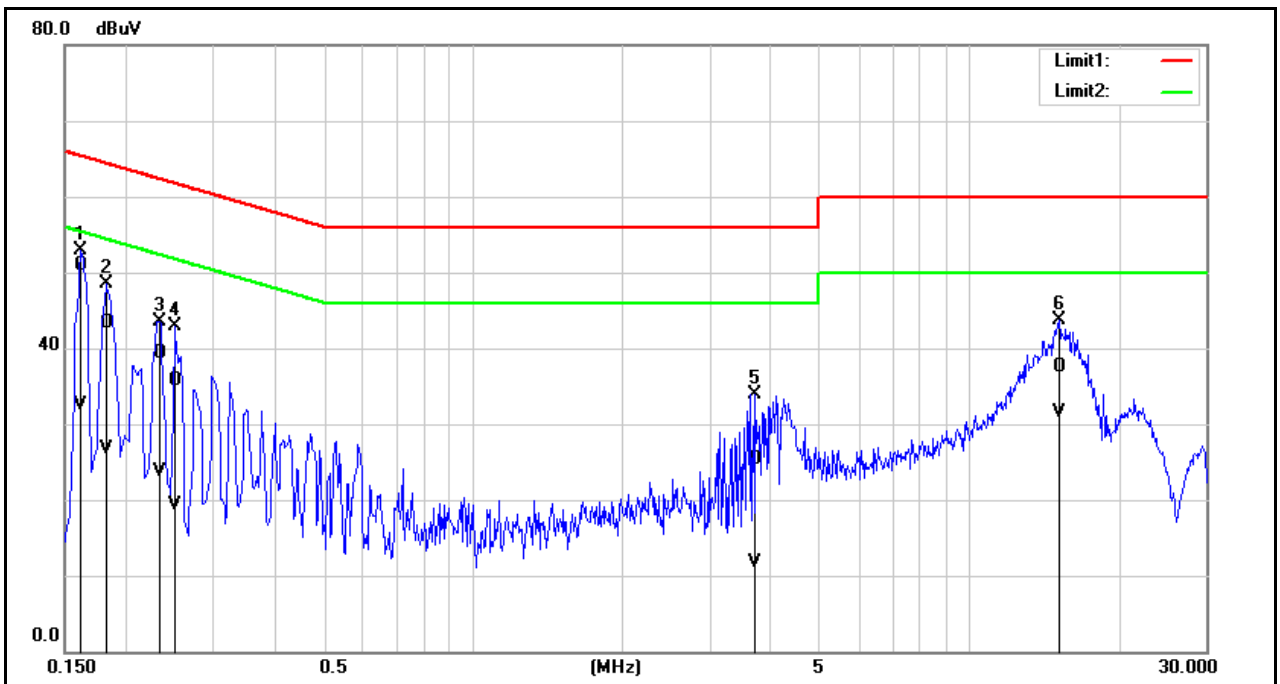

No.	Frequency (MHz)	QP reading (dBuV)	AVG reading (dBuV)	Correction factor (dB)	QP result (dBuV)	AVG result (dBuV)	QP limit (dBuV)	AVG limit (dBuV)	QP margin (dB)	AVG margin (dB)	Remark
1	0.1620	41.46	22.99	9.54	51.00	32.53	65.36	55.36	-14.36	-22.83	Pass
2	0.1820	33.73	17.14	9.54	43.27	26.68	64.39	54.39	-21.12	-27.71	Pass
3	0.2340	29.76	14.23	9.54	39.30	23.77	62.31	52.31	-23.01	-28.54	Pass
4	0.2500	26.08	9.80	9.54	35.62	19.34	61.76	51.76	-26.14	-32.42	Pass
5	3.7060	15.63	2.05	9.66	25.29	11.71	56.00	46.00	-30.71	-34.29	Pass
6	15.1660	27.66	21.77	9.83	37.49	31.60	60.00	50.00	-22.51	-18.40	Pass

Note: 1. Result (dBuV) = Correction factor (dB) + Reading(dBuV).

2. Correction factor (dB) = Cable loss (dB) + L.I.S.N. factor (dB).

Standard:	FCC Part 15.247	Line:	N
Test item:	Conducted Emission	Power:	AC 120 V/60 Hz
Mode:	Mode 1		
Description:			

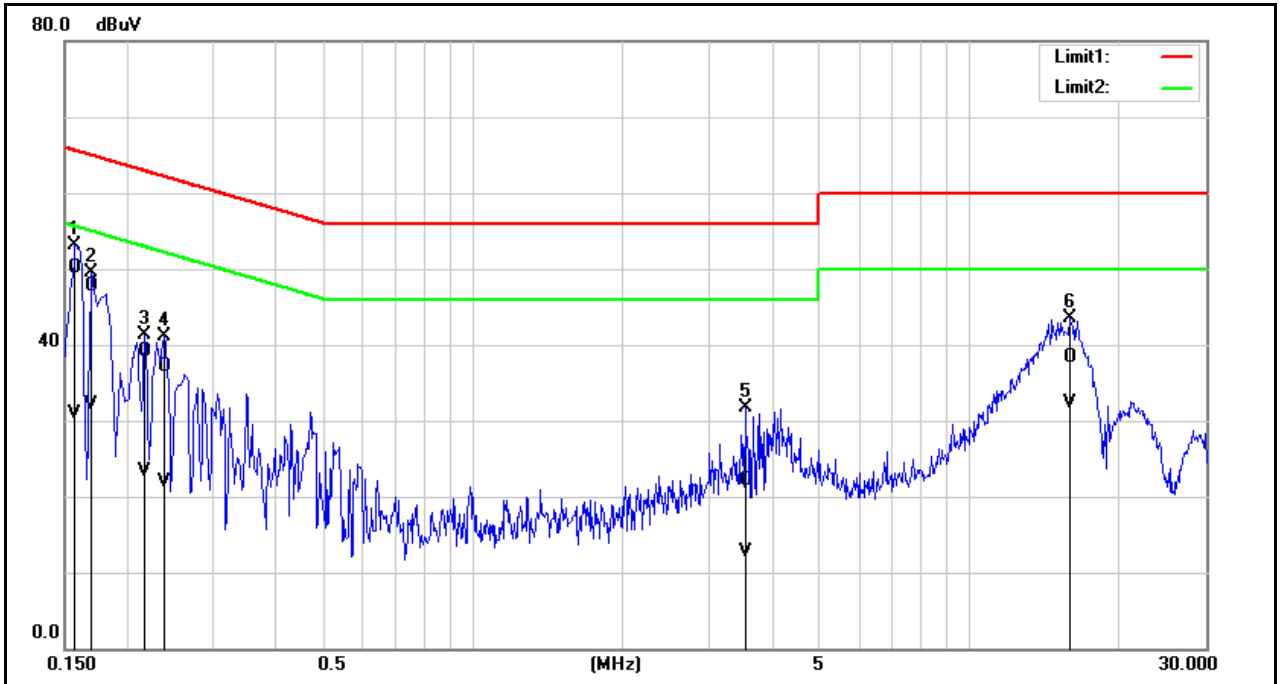

No.	Frequency (MHz)	QP reading (dBuV)	AVG reading (dBuV)	Correction factor (dB)	QP result (dBuV)	AVG result (dBuV)	QP limit (dBuV)	AVG limit (dBuV)	QP margin (dB)	AVG margin (dB)	Remark
1	0.1580	40.52	21.23	9.60	50.12	30.83	65.57	55.57	-15.45	-24.74	Pass
2	0.1700	38.16	22.49	9.60	47.76	32.09	64.96	54.96	-17.20	-22.87	Pass
3	0.2180	29.54	13.67	9.60	39.14	23.27	62.89	52.89	-23.75	-29.62	Pass
4	0.2380	27.50	12.24	9.60	37.10	21.84	62.17	52.17	-25.07	-30.33	Pass
5	3.5300	12.34	2.94	9.72	22.06	12.66	56.00	46.00	-33.94	-33.34	Pass
6	15.9620	28.28	22.32	9.97	38.25	32.29	60.00	50.00	-21.75	-17.71	Pass

Note: 1. Result (dBuV) = Correction factor (dB) + Reading(dBuV).
2. Correction factor (dB) = Cable loss (dB) + L.I.S.N. factor (dB).

5.2. Conducted Test Results

Duty cycle

Test Mode	Frequency (MHz)	on time (ms)	on+off time (ms)	Duty cycle	Duty Factor (dB)	1/T Minimum VBW (kHz)
Mode 2	2402	1.110	1.248	0.890	0.507	0.901
Mode 4	2402	17.180	17.480	0.983	0.075	0.010

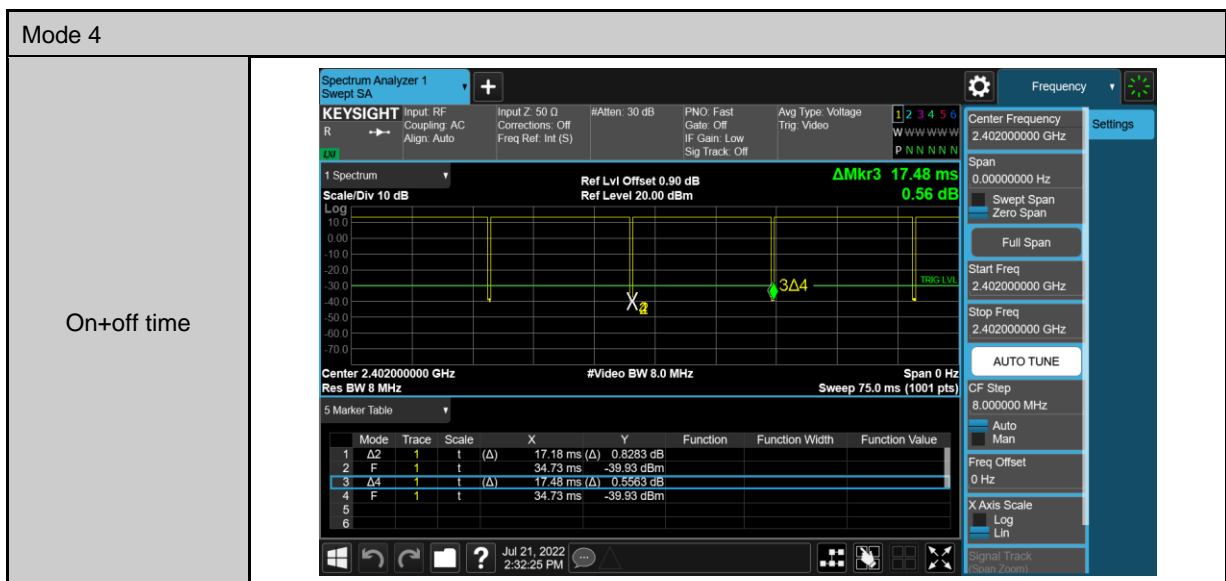
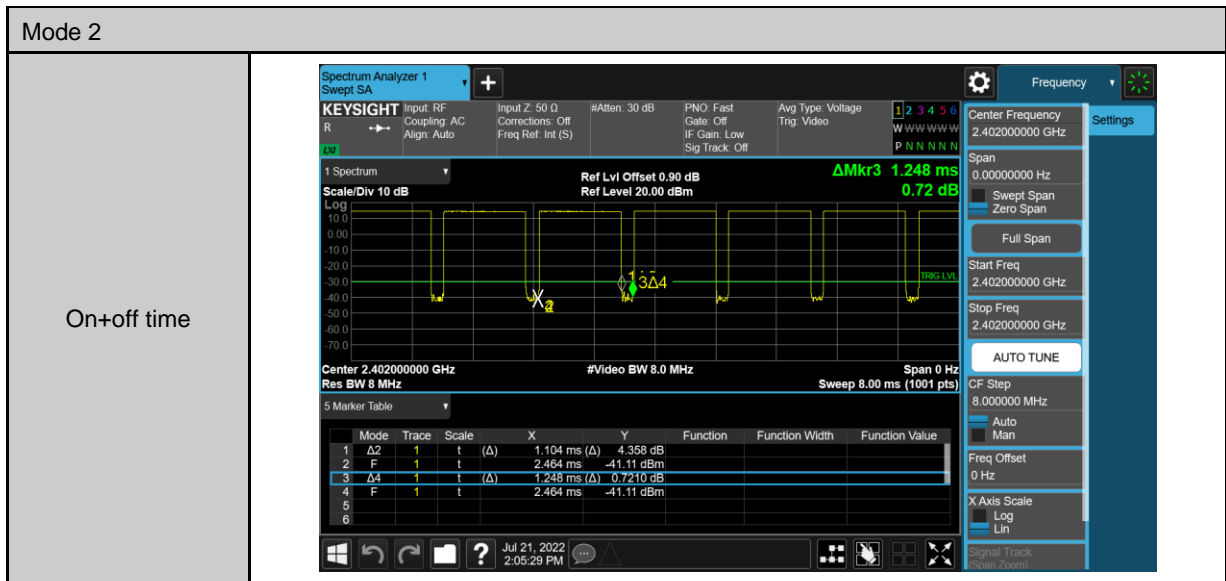

Maximum Conducted Output Power Measurement

Test Mode	Frequency (MHz)	RF Power setting in Test Software	Test Software Version
Mode 1	2402	13.00	MForm V1.16.1.6
	2440	13.00	
	2480	13.00	
Mode 2	2402	14.00	
	2440	14.00	
	2480	14.00	
Mode 3	2402	13.00	
	2440	13.00	
	2480	13.00	
Mode 4	2402	13.00	
	2440	13.00	
	2480	13.00	

Test Mode	Mode 1				
Frequency (MHz)	Average Power		Peak Power		Limit (dBm)
	(dBm)	(W)	(dBm)	(W)	
2402	12.76	0.01888	12.98	0.01986	≤ 30
2440	13.16	0.02070	13.50	0.02239	≤ 30
2480	12.75	0.01884	12.83	0.01919	≤ 30

Test Mode	Mode 2				
Frequency (MHz)	Average Power		Peak Power		Limit (dBm)
	(dBm)	(W)	(dBm)	(W)	
2402	14.35	0.02723	14.58	0.02871	≤ 30
2440	14.27	0.02673	14.48	0.02805	≤ 30
2480	13.83	0.02415	14.09	0.02564	≤ 30

Test Mode	Mode 3				
Frequency (MHz)	Average Power		Peak Power		Limit (dBm)
	(dBm)	(W)	(dBm)	(W)	
2402	13.21	0.02094	13.40	0.02188	≤ 30
2440	13.19	0.02084	13.56	0.02270	≤ 30
2480	12.75	0.01884	12.96	0.01977	≤ 30

Test Mode	Mode 4				
Frequency (MHz)	Average Power		Peak Power		Limit (dBm)
	(dBm)	(W)	(dBm)	(W)	
2402	13.25	0.02113	13.45	0.02213	≤ 30
2440	13.30	0.02138	13.60	0.02291	≤ 30
2480	12.76	0.01888	12.98	0.01986	≤ 30



Note: The relevant measured result has the offset with cable loss already.



6 dB RF Bandwidth Measurement

Test Mode	Mode 2	
Frequency (MHz)	Measurement Results (kHz)	Limit (kHz)
2402	1206.000	≥ 500
2440	1205.000	≥ 500
2480	1250.000	≥ 500

Test Mode	Mode 4	
Frequency (MHz)	Measurement Results (kHz)	Limit (kHz)
2402	690.100	≥ 500
2440	685.800	≥ 500
2480	689.800	≥ 500

■ Test Graphs

Mode 2													
2402 MHz	 <p>KEYSIGHT Spectrum Analyzer 1 Occupied BW</p> <p>Center Freq: 2.40200000 GHz Span: 6.0000 MHz Scale/Div: 10.0 dB Ref Lvl Offset: 0.90 dB Ref Value: 20.00 dBm</p> <p>2 Metrics:</p> <table border="1"> <tr> <td>Occupied Bandwidth</td> <td>2.0719 MHz</td> <td>Total Power</td> <td>22.1 dBm</td> </tr> <tr> <td>Transmit Freq Error</td> <td>11.407 kHz</td> <td>% of OBW Power</td> <td>99.00 %</td> </tr> <tr> <td>x dB Bandwidth</td> <td>1.206 MHz</td> <td>x dB</td> <td>-6.00 dB</td> </tr> </table> <p>Jul 21, 2022 2:05:52 PM</p>	Occupied Bandwidth	2.0719 MHz	Total Power	22.1 dBm	Transmit Freq Error	11.407 kHz	% of OBW Power	99.00 %	x dB Bandwidth	1.206 MHz	x dB	-6.00 dB
Occupied Bandwidth	2.0719 MHz	Total Power	22.1 dBm										
Transmit Freq Error	11.407 kHz	% of OBW Power	99.00 %										
x dB Bandwidth	1.206 MHz	x dB	-6.00 dB										
2440 MHz	 <p>KEYSIGHT Spectrum Analyzer 1 Occupied BW</p> <p>Center Freq: 2.44000000 GHz Span: 6.0000 MHz Scale/Div: 10.0 dB Ref Lvl Offset: 0.90 dB Ref Value: 20.00 dBm</p> <p>2 Metrics:</p> <table border="1"> <tr> <td>Occupied Bandwidth</td> <td>2.0720 MHz</td> <td>Total Power</td> <td>22.0 dBm</td> </tr> <tr> <td>Transmit Freq Error</td> <td>11.135 kHz</td> <td>% of OBW Power</td> <td>99.00 %</td> </tr> <tr> <td>x dB Bandwidth</td> <td>1.205 MHz</td> <td>x dB</td> <td>-6.00 dB</td> </tr> </table> <p>Jul 21, 2022 2:11:17 PM</p>	Occupied Bandwidth	2.0720 MHz	Total Power	22.0 dBm	Transmit Freq Error	11.135 kHz	% of OBW Power	99.00 %	x dB Bandwidth	1.205 MHz	x dB	-6.00 dB
Occupied Bandwidth	2.0720 MHz	Total Power	22.0 dBm										
Transmit Freq Error	11.135 kHz	% of OBW Power	99.00 %										
x dB Bandwidth	1.205 MHz	x dB	-6.00 dB										
2480 MHz	 <p>KEYSIGHT Spectrum Analyzer 1 Occupied BW</p> <p>Center Freq: 2.48000000 GHz Span: 6.0000 MHz Scale/Div: 10.0 dB Ref Lvl Offset: 0.90 dB Ref Value: 20.00 dBm</p> <p>2 Metrics:</p> <table border="1"> <tr> <td>Occupied Bandwidth</td> <td>2.0699 MHz</td> <td>Total Power</td> <td>21.7 dBm</td> </tr> <tr> <td>Transmit Freq Error</td> <td>10.808 kHz</td> <td>% of OBW Power</td> <td>99.00 %</td> </tr> <tr> <td>x dB Bandwidth</td> <td>1.250 MHz</td> <td>x dB</td> <td>-6.00 dB</td> </tr> </table> <p>Jul 21, 2022 2:15:43 PM</p>	Occupied Bandwidth	2.0699 MHz	Total Power	21.7 dBm	Transmit Freq Error	10.808 kHz	% of OBW Power	99.00 %	x dB Bandwidth	1.250 MHz	x dB	-6.00 dB
Occupied Bandwidth	2.0699 MHz	Total Power	21.7 dBm										
Transmit Freq Error	10.808 kHz	% of OBW Power	99.00 %										
x dB Bandwidth	1.250 MHz	x dB	-6.00 dB										

Mode 4	
2402 MHz	 <p>The screenshot shows the Keysight Spectrum Analyzer interface for a 2402 MHz signal. The center frequency is 2.4020000 GHz, with a span of 3.0000 MHz and a resolution bandwidth of 100.00 kHz. The occupied bandwidth is 1.0580 MHz, and the total power is 16.9 dBm. The transmit frequency error is -314 Hz, and the percentage of occupied bandwidth power is 99.00%.</p>
2440 MHz	 <p>The screenshot shows the Keysight Spectrum Analyzer interface for a 2440 MHz signal. The center frequency is 2.4400000 GHz, with a span of 3.0000 MHz and a resolution bandwidth of 100.00 kHz. The occupied bandwidth is 1.0573 MHz, and the total power is 17.0 dBm. The transmit frequency error is -569 Hz, and the percentage of occupied bandwidth power is 99.00%.</p>
2480 MHz	 <p>The screenshot shows the Keysight Spectrum Analyzer interface for a 2480 MHz signal. The center frequency is 2.4800000 GHz, with a span of 3.0000 MHz and a resolution bandwidth of 100.00 kHz. The occupied bandwidth is 1.0575 MHz, and the total power is 16.7 dBm. The transmit frequency error is -724 Hz, and the percentage of occupied bandwidth power is 99.00%.</p>

Maximum Power Density Measurement

Test Mode	Mode 2	
Frequency (MHz)	Measurement Results (dBm/ 3kHz)	Limit (dBm)
2402	-4.470	≤ 8
2440	-4.480	≤ 8
2480	-4.510	≤ 8

Test Mode	Mode 4	
Frequency (MHz)	Measurement Results (dBm/ 3kHz)	Limit (dBm)
2402	7.460	≤ 8
2440	7.410	≤ 8
2480	7.280	≤ 8

■ Test Graphs

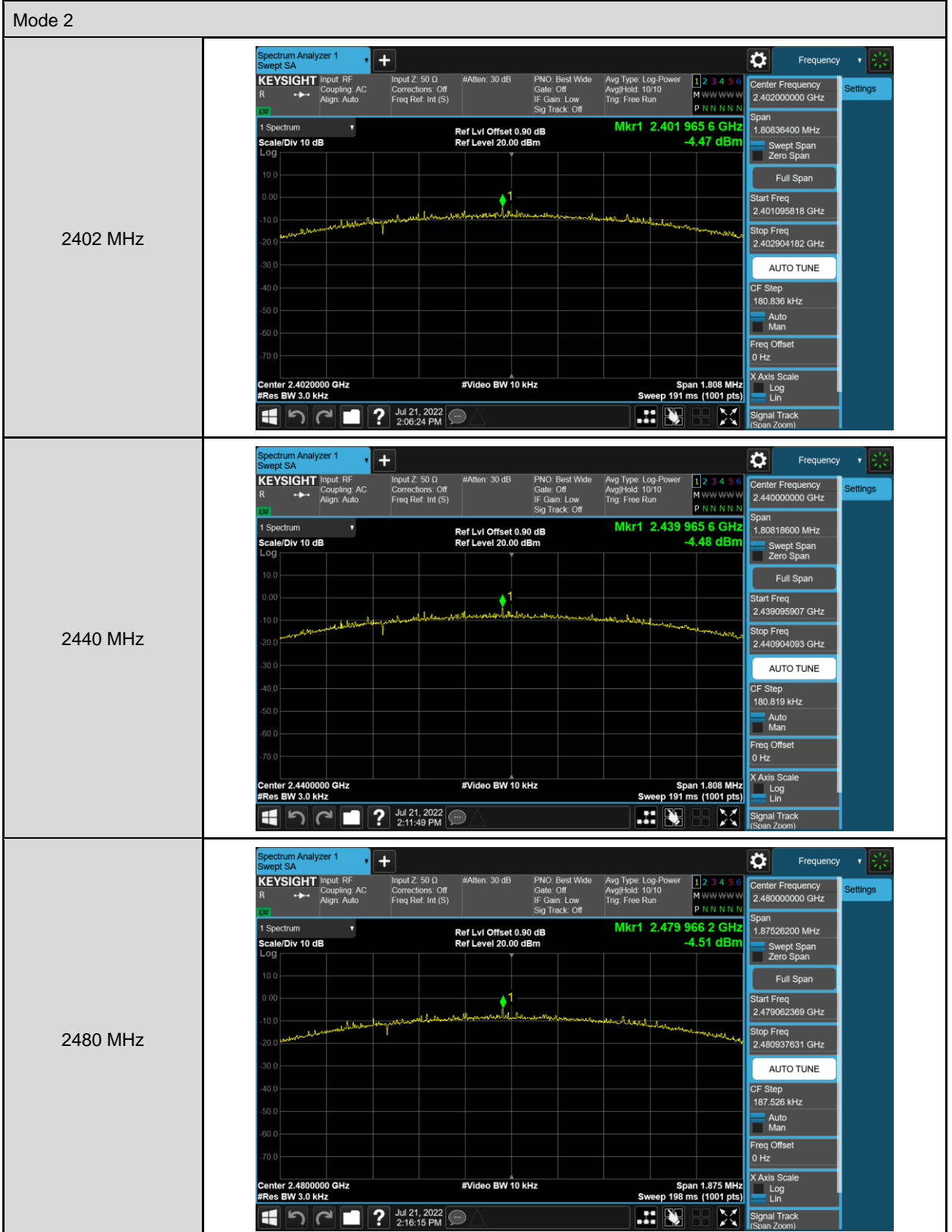

Mode 4	
2402 MHz	
2440 MHz	
2480 MHz	

Out of Band Conducted Emissions Measurement

■ Test Graphs

Reference level

Mode 2	
2402 MHz	
2440 MHz	
2480 MHz	

Mode 4	
2402 MHz	<p>Center Frequency: 2.40200000 GHz Span: 1.03515600 MHz Start Freq: 2.401482422 GHz Stop Freq: 2.402517578 GHz Mkr1 2.402 000 0 GHz 10.41 dBm</p>
2440 MHz	<p>Center Frequency: 2.44000000 GHz Span: 1.02872800 MHz Start Freq: 2.439485636 GHz Stop Freq: 2.440514364 GHz Mkr1 2.440 001 0 GHz 10.50 dBm</p>
2480 MHz	<p>Center Frequency: 2.48000000 GHz Span: 1.03477400 MHz Start Freq: 2.479482613 GHz Stop Freq: 2.480517387 GHz Mkr1 2.479 995 9 GHz 10.15 dBm</p>

Out of Band Conducted Emissions

Mode 2																																																									
2402 MHz	<table border="1"> <thead> <tr> <th>Mode</th> <th>Trace</th> <th>Scale</th> <th>X</th> <th>Y</th> <th>Function</th> <th>Function Width</th> <th>Function Value</th> </tr> </thead> <tbody> <tr> <td>1</td> <td>N</td> <td>1</td> <td>f</td> <td>2.402 GHz</td> <td></td> <td></td> <td>12.15 dBm</td> </tr> <tr> <td>2</td> <td>N</td> <td>1</td> <td>f</td> <td>24.691 GHz</td> <td></td> <td></td> <td>-39.13 dBm</td> </tr> <tr> <td>3</td> <td></td> <td></td> <td></td> <td></td> <td></td> <td></td> <td></td> </tr> <tr> <td>4</td> <td></td> <td></td> <td></td> <td></td> <td></td> <td></td> <td></td> </tr> <tr> <td>5</td> <td></td> <td></td> <td></td> <td></td> <td></td> <td></td> <td></td> </tr> <tr> <td>6</td> <td></td> <td></td> <td></td> <td></td> <td></td> <td></td> <td></td> </tr> </tbody> </table>	Mode	Trace	Scale	X	Y	Function	Function Width	Function Value	1	N	1	f	2.402 GHz			12.15 dBm	2	N	1	f	24.691 GHz			-39.13 dBm	3								4								5								6							
Mode	Trace	Scale	X	Y	Function	Function Width	Function Value																																																		
1	N	1	f	2.402 GHz			12.15 dBm																																																		
2	N	1	f	24.691 GHz			-39.13 dBm																																																		
3																																																									
4																																																									
5																																																									
6																																																									
2440 MHz	<table border="1"> <thead> <tr> <th>Mode</th> <th>Trace</th> <th>Scale</th> <th>X</th> <th>Y</th> <th>Function</th> <th>Function Width</th> <th>Function Value</th> </tr> </thead> <tbody> <tr> <td>1</td> <td>N</td> <td>1</td> <td>f</td> <td>2.440 GHz</td> <td></td> <td></td> <td>13.38 dBm</td> </tr> <tr> <td>2</td> <td>N</td> <td>1</td> <td>f</td> <td>24.727 GHz</td> <td></td> <td></td> <td>-39.57 dBm</td> </tr> <tr> <td>3</td> <td></td> <td></td> <td></td> <td></td> <td></td> <td></td> <td></td> </tr> <tr> <td>4</td> <td></td> <td></td> <td></td> <td></td> <td></td> <td></td> <td></td> </tr> <tr> <td>5</td> <td></td> <td></td> <td></td> <td></td> <td></td> <td></td> <td></td> </tr> <tr> <td>6</td> <td></td> <td></td> <td></td> <td></td> <td></td> <td></td> <td></td> </tr> </tbody> </table>	Mode	Trace	Scale	X	Y	Function	Function Width	Function Value	1	N	1	f	2.440 GHz			13.38 dBm	2	N	1	f	24.727 GHz			-39.57 dBm	3								4								5								6							
Mode	Trace	Scale	X	Y	Function	Function Width	Function Value																																																		
1	N	1	f	2.440 GHz			13.38 dBm																																																		
2	N	1	f	24.727 GHz			-39.57 dBm																																																		
3																																																									
4																																																									
5																																																									
6																																																									
2480 MHz	<table border="1"> <thead> <tr> <th>Mode</th> <th>Trace</th> <th>Scale</th> <th>X</th> <th>Y</th> <th>Function</th> <th>Function Width</th> <th>Function Value</th> </tr> </thead> <tbody> <tr> <td>1</td> <td>N</td> <td>1</td> <td>f</td> <td>2.480 GHz</td> <td></td> <td></td> <td>13.37 dBm</td> </tr> <tr> <td>2</td> <td>N</td> <td>1</td> <td>f</td> <td>24.800 GHz</td> <td></td> <td></td> <td>-38.67 dBm</td> </tr> <tr> <td>3</td> <td></td> <td></td> <td></td> <td></td> <td></td> <td></td> <td></td> </tr> <tr> <td>4</td> <td></td> <td></td> <td></td> <td></td> <td></td> <td></td> <td></td> </tr> <tr> <td>5</td> <td></td> <td></td> <td></td> <td></td> <td></td> <td></td> <td></td> </tr> <tr> <td>6</td> <td></td> <td></td> <td></td> <td></td> <td></td> <td></td> <td></td> </tr> </tbody> </table>	Mode	Trace	Scale	X	Y	Function	Function Width	Function Value	1	N	1	f	2.480 GHz			13.37 dBm	2	N	1	f	24.800 GHz			-38.67 dBm	3								4								5								6							
Mode	Trace	Scale	X	Y	Function	Function Width	Function Value																																																		
1	N	1	f	2.480 GHz			13.37 dBm																																																		
2	N	1	f	24.800 GHz			-38.67 dBm																																																		
3																																																									
4																																																									
5																																																									
6																																																									

Mode 4																																																									
2402 MHz	<table border="1"> <thead> <tr> <th>Mode</th> <th>Trace</th> <th>Scale</th> <th>X</th> <th>Y</th> <th>Function</th> <th>Function Width</th> <th>Function Value</th> </tr> </thead> <tbody> <tr> <td>1</td> <td>N</td> <td>1</td> <td>f</td> <td>2.402 2 GHz</td> <td>10.44 dBm</td> <td></td> <td></td> </tr> <tr> <td>2</td> <td>N</td> <td>1</td> <td>f</td> <td>24.742 2 GHz</td> <td>-38.01 dBm</td> <td></td> <td></td> </tr> <tr> <td>3</td> <td></td> <td></td> <td></td> <td></td> <td></td> <td></td> <td></td> </tr> <tr> <td>4</td> <td></td> <td></td> <td></td> <td></td> <td></td> <td></td> <td></td> </tr> <tr> <td>5</td> <td></td> <td></td> <td></td> <td></td> <td></td> <td></td> <td></td> </tr> <tr> <td>6</td> <td></td> <td></td> <td></td> <td></td> <td></td> <td></td> <td></td> </tr> </tbody> </table>	Mode	Trace	Scale	X	Y	Function	Function Width	Function Value	1	N	1	f	2.402 2 GHz	10.44 dBm			2	N	1	f	24.742 2 GHz	-38.01 dBm			3								4								5								6							
Mode	Trace	Scale	X	Y	Function	Function Width	Function Value																																																		
1	N	1	f	2.402 2 GHz	10.44 dBm																																																				
2	N	1	f	24.742 2 GHz	-38.01 dBm																																																				
3																																																									
4																																																									
5																																																									
6																																																									
2440 MHz	<table border="1"> <thead> <tr> <th>Mode</th> <th>Trace</th> <th>Scale</th> <th>X</th> <th>Y</th> <th>Function</th> <th>Function Width</th> <th>Function Value</th> </tr> </thead> <tbody> <tr> <td>1</td> <td>N</td> <td>1</td> <td>f</td> <td>2.440 2 GHz</td> <td>10.32 dBm</td> <td></td> <td></td> </tr> <tr> <td>2</td> <td>N</td> <td>1</td> <td>f</td> <td>24.770 9 GHz</td> <td>-38.76 dBm</td> <td></td> <td></td> </tr> <tr> <td>3</td> <td></td> <td></td> <td></td> <td></td> <td></td> <td></td> <td></td> </tr> <tr> <td>4</td> <td></td> <td></td> <td></td> <td></td> <td></td> <td></td> <td></td> </tr> <tr> <td>5</td> <td></td> <td></td> <td></td> <td></td> <td></td> <td></td> <td></td> </tr> <tr> <td>6</td> <td></td> <td></td> <td></td> <td></td> <td></td> <td></td> <td></td> </tr> </tbody> </table>	Mode	Trace	Scale	X	Y	Function	Function Width	Function Value	1	N	1	f	2.440 2 GHz	10.32 dBm			2	N	1	f	24.770 9 GHz	-38.76 dBm			3								4								5								6							
Mode	Trace	Scale	X	Y	Function	Function Width	Function Value																																																		
1	N	1	f	2.440 2 GHz	10.32 dBm																																																				
2	N	1	f	24.770 9 GHz	-38.76 dBm																																																				
3																																																									
4																																																									
5																																																									
6																																																									
2480 MHz	<table border="1"> <thead> <tr> <th>Mode</th> <th>Trace</th> <th>Scale</th> <th>X</th> <th>Y</th> <th>Function</th> <th>Function Width</th> <th>Function Value</th> </tr> </thead> <tbody> <tr> <td>1</td> <td>N</td> <td>1</td> <td>f</td> <td>2.480 2 GHz</td> <td>10.10 dBm</td> <td></td> <td></td> </tr> <tr> <td>2</td> <td>N</td> <td>1</td> <td>f</td> <td>24.762 2 GHz</td> <td>-38.41 dBm</td> <td></td> <td></td> </tr> <tr> <td>3</td> <td></td> <td></td> <td></td> <td></td> <td></td> <td></td> <td></td> </tr> <tr> <td>4</td> <td></td> <td></td> <td></td> <td></td> <td></td> <td></td> <td></td> </tr> <tr> <td>5</td> <td></td> <td></td> <td></td> <td></td> <td></td> <td></td> <td></td> </tr> <tr> <td>6</td> <td></td> <td></td> <td></td> <td></td> <td></td> <td></td> <td></td> </tr> </tbody> </table>	Mode	Trace	Scale	X	Y	Function	Function Width	Function Value	1	N	1	f	2.480 2 GHz	10.10 dBm			2	N	1	f	24.762 2 GHz	-38.41 dBm			3								4								5								6							
Mode	Trace	Scale	X	Y	Function	Function Width	Function Value																																																		
1	N	1	f	2.480 2 GHz	10.10 dBm																																																				
2	N	1	f	24.762 2 GHz	-38.41 dBm																																																				
3																																																									
4																																																									
5																																																									
6																																																									

Conducted Band Edge

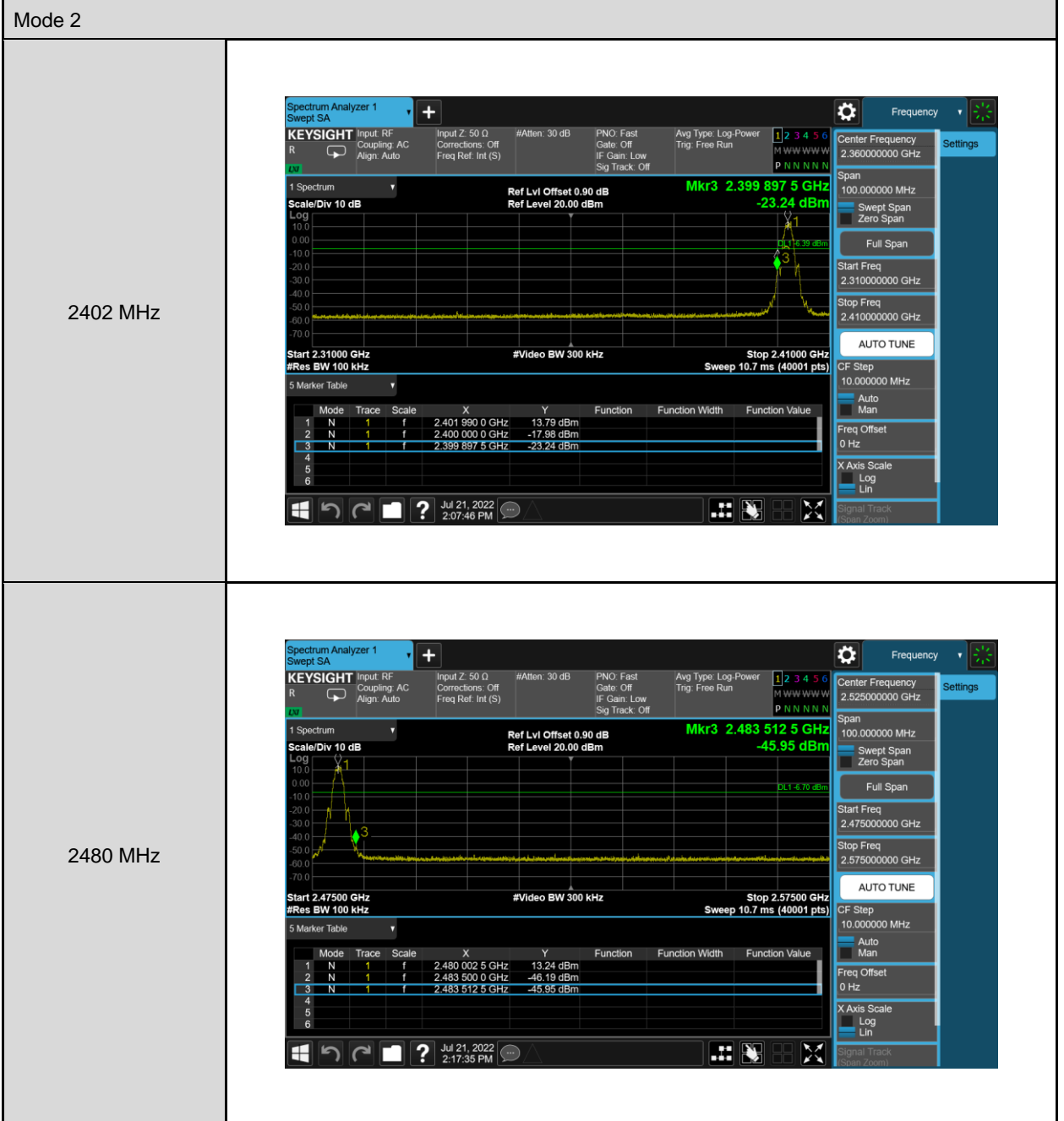

Mode 4																																																									
2402 MHz	<thead> <tr> <th>Mode</th> <th>Trace</th> <th>Scale</th> <th>X</th> <th>Y</th> <th>Function</th> <th>Function Width</th> <th>Function Value</th> </tr> </thead> <tbody> <tr> <td>1</td> <td>N</td> <td>1</td> <td>f</td> <td>2.402 002 5 GHz</td> <td></td> <td></td> <td>10.43 dBm</td> </tr> <tr> <td>2</td> <td>N</td> <td>1</td> <td>f</td> <td>2.400 000 0 GHz</td> <td></td> <td></td> <td>-50.82 dBm</td> </tr> <tr> <td>3</td> <td>N</td> <td>1</td> <td>f</td> <td>2.399 865 0 GHz</td> <td></td> <td></td> <td>-50.76 dBm</td> </tr> <tr> <td>4</td> <td></td> <td></td> <td></td> <td></td> <td></td> <td></td> <td></td> </tr> <tr> <td>5</td> <td></td> <td></td> <td></td> <td></td> <td></td> <td></td> <td></td> </tr> <tr> <td>6</td> <td></td> <td></td> <td></td> <td></td> <td></td> <td></td> <td></td> </tr> </tbody>	Mode	Trace	Scale	X	Y	Function	Function Width	Function Value	1	N	1	f	2.402 002 5 GHz			10.43 dBm	2	N	1	f	2.400 000 0 GHz			-50.82 dBm	3	N	1	f	2.399 865 0 GHz			-50.76 dBm	4								5								6							
Mode	Trace	Scale	X	Y	Function	Function Width	Function Value																																																		
1	N	1	f	2.402 002 5 GHz			10.43 dBm																																																		
2	N	1	f	2.400 000 0 GHz			-50.82 dBm																																																		
3	N	1	f	2.399 865 0 GHz			-50.76 dBm																																																		
4																																																									
5																																																									
6																																																									

| 2480 MHz | | Mode | Trace | Scale | X | Y | Function | Function Width | Function Value | | --- | --- | --- | --- | --- | --- | --- | --- | | 1 | N | 1 | f | 2.480 002 5 GHz | | | 10.16 dBm | | 2 | N | 1 | f | 2.483 500 0 GHz | | | -54.83 dBm | | 3 | N | 1 | f | 2.484 082 5 GHz | | | -53.09 dBm | | 4 | | | | | | | | | 5 | | | | | | | | | 6 | | | | | | | | |

5.3. Radiated Emission Measurement

PCB Dipole Antenna

Below 1 GHz

Standard:	FCC Part 15.247	Test Distance:	3 m
Test item:	Radiated Emission		
Frequency:	2480 MHz		
Mode:	Mode 1		
Ant.Polar.:	Horizontal		

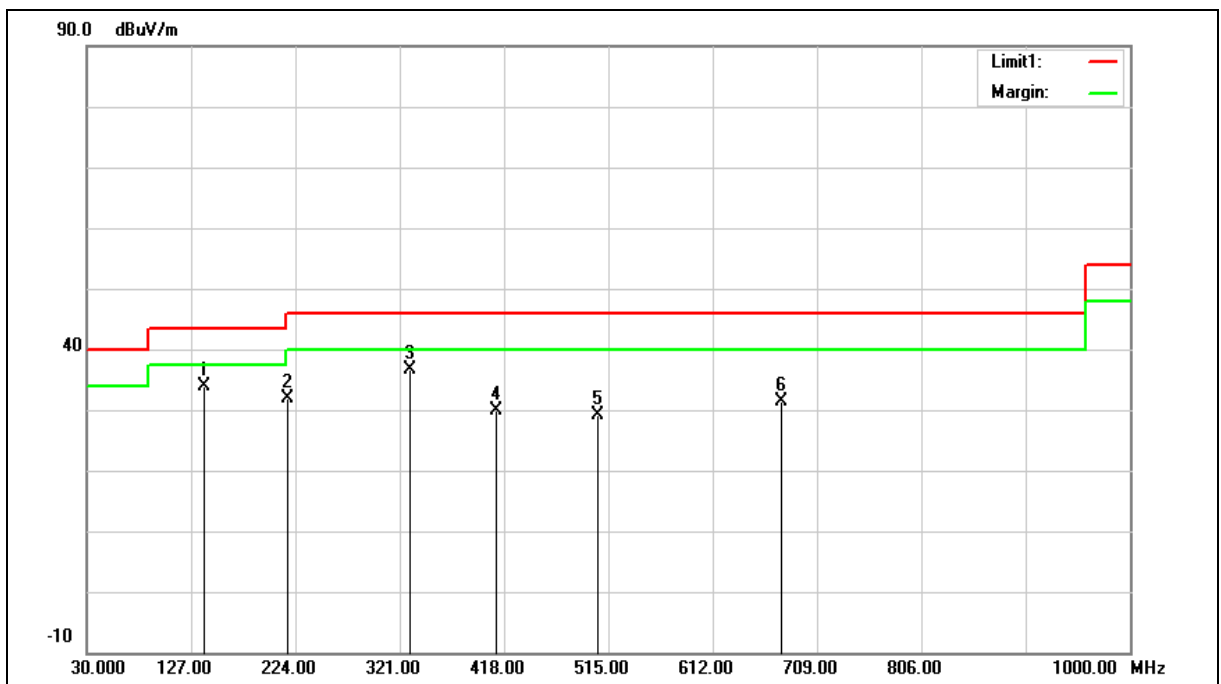

No.	Frequency (MHz)	Reading (dBuV)	Correct Factor (dB/m)	Result (dBuV/m)	Limit (dBuV/m)	Margin (dB)	Remark
1	139.6100	41.51	-7.61	33.90	43.50	-9.60	QP
2	216.2400	41.52	-9.75	31.77	46.00	-14.23	QP
3	330.7000	42.43	-5.84	36.59	46.00	-9.41	QP
4	411.2100	33.48	-3.66	29.82	46.00	-16.18	QP
5	505.3000	30.97	-1.86	29.11	46.00	-16.89	QP
6	676.0200	29.38	1.92	31.30	46.00	-14.70	QP

Note:1.Result (dBuV/m) = Correct Factor (dB/m) + Reading(dBuV).

2.Correction factor (dB/m) = Antenna Factor (dB/m) + Cable loss (dB) – Pre-Amplifier gain (dB).

3.When the peak results are less than average limit, so not need to evaluate the average.

Standard:	FCC Part 15.247	Test Distance:	3 m
Test item:	Radiated Emission		
Frequency:	2480 MHz		
Mode:	Mode 1		
Ant.Polar.:	Vertical		

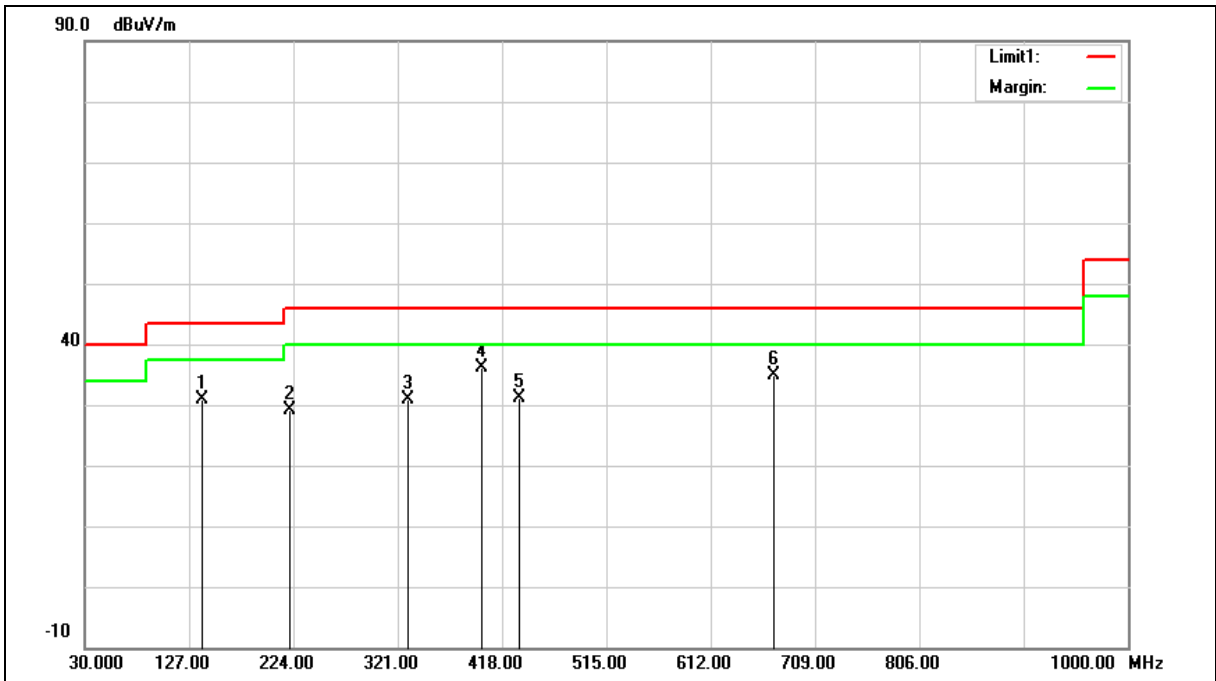

No.	Frequency (MHz)	Reading (dBuV)	Correct Factor (dB/m)	Result (dBuV/m)	Limit (dBuV/m)	Margin (dB)	Remark
1	139.6100	38.40	-7.61	30.79	43.50	-12.71	QP
2	221.0900	38.73	-9.64	29.09	46.00	-16.91	QP
3	330.7000	36.80	-5.84	30.96	46.00	-15.04	QP
4	398.6000	40.09	-3.93	36.16	46.00	-9.84	QP
5	433.5200	34.23	-3.20	31.03	46.00	-14.97	QP
6	671.1700	33.16	1.82	34.98	46.00	-11.02	QP

Note:1.Result (dBuV/m) = Correct Factor (dB/m) + Reading(dBuV).

2.Correction factor (dB/m) = Antenna Factor (dB/m) + Cable loss (dB) – Pre-Amplifier gain (dB).

3.When the peak results are less than average limit, so not need to evaluate the average.

Harmonic

Above 1 GHz

Standard:	FCC Part 15.247	Test Distance:	3 m
Test item:	Harmonic		
Frequency:	2402 MHz		
Mode:	Mode 2		
Ant.Polar.:	Horizontal		

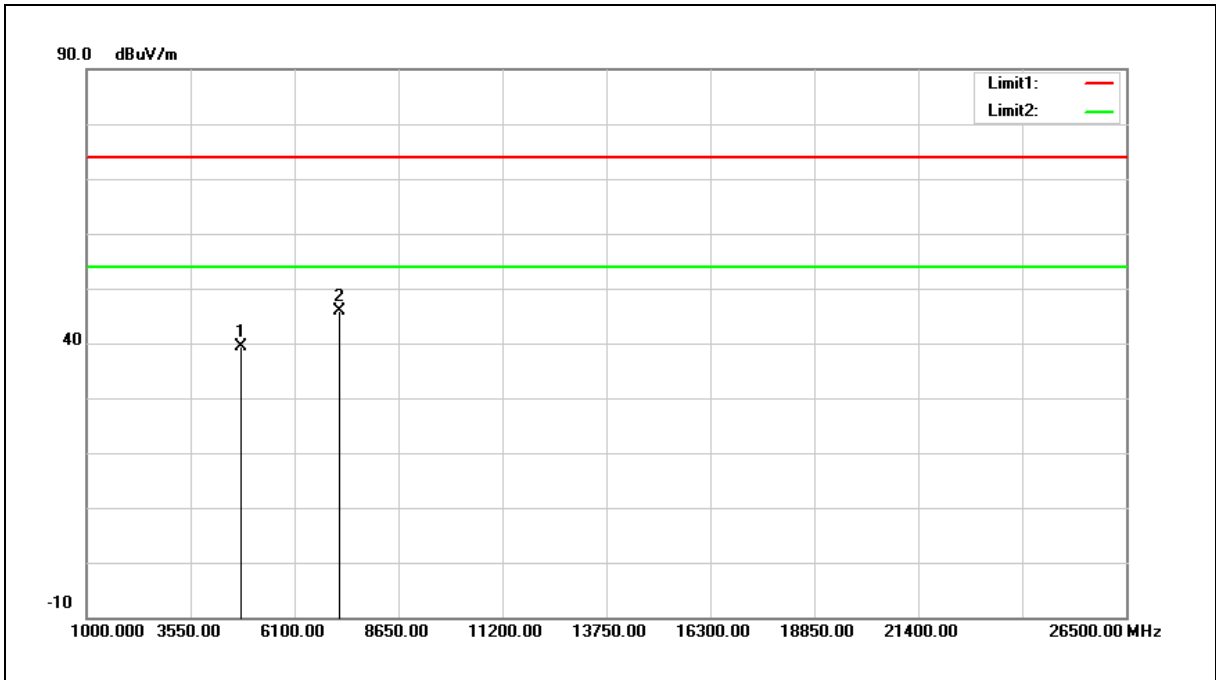

No.	Frequency (MHz)	Reading (dBuV)	Correct Factor (dB/m)	Result (dBuV/m)	Limit (dBuV/m)	Margin (dB)	Remark
1	4804.000	35.37	3.97	39.34	74.00	-34.66	peak
2	7206.000	35.80	10.10	45.90	74.00	-28.10	peak

Note:1.Result (dBuV/m) = Correct Factor (dB/m) + Reading(dBuV).

2.Correction factor (dB/m) = Antenna Factor (dB/m) + Cable loss (dB) – Pre-Amplifier gain (dB).

3.When the peak results are less than average limit, so not need to evaluate the average.

Standard:	FCC Part 15.247	Test Distance:	3 m
Test item:	Harmonic		
Frequency:	2402 MHz		
Mode:	Mode 2		
Ant.Polar.:	Vertical		

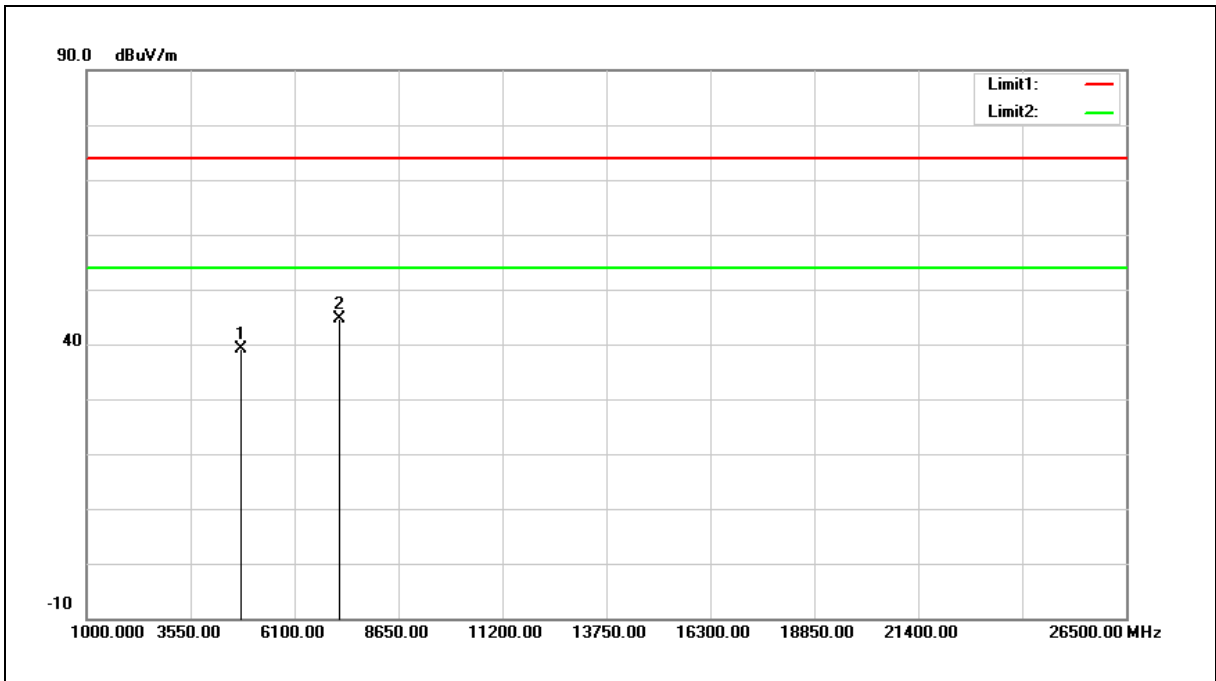

No.	Frequency (MHz)	Reading (dBuV)	Correct Factor (dB/m)	Result (dBuV/m)	Limit (dBuV/m)	Margin (dB)	Remark
1	4804.000	35.20	3.97	39.17	74.00	-34.83	peak
2	7206.000	34.41	10.10	44.51	74.00	-29.49	peak

Note:1.Result (dBuV/m) = Correct Factor (dB/m) + Reading(dBuV).

2.Correction factor (dB/m) = Antenna Factor (dB/m) + Cable loss (dB) – Pre-Amplifier gain (dB).

3.When the peak results are less than average limit, so not need to evaluate the average.

Standard:	FCC Part 15.247	Test Distance:	3 m
Test item:	Harmonic		
Frequency:	2440 MHz		
Mode:	Mode 2		
Ant.Polar.:	Horizontal		

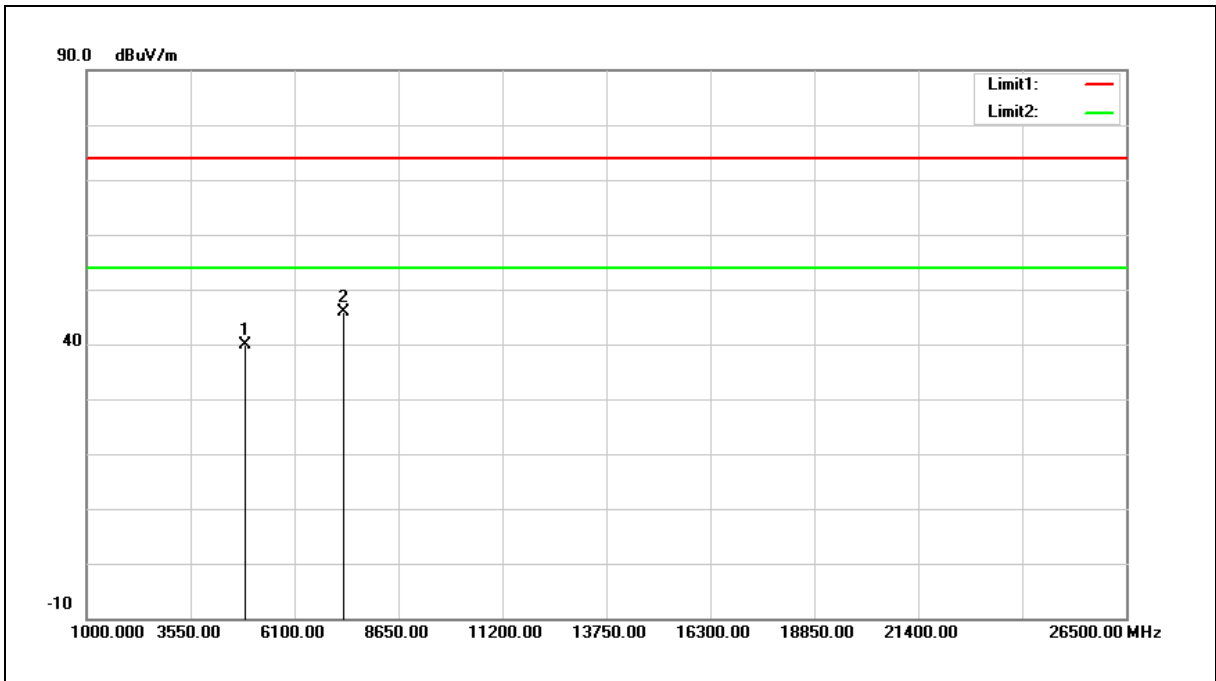

No.	Frequency (MHz)	Reading (dBuV)	Correct Factor (dB/m)	Result (dBuV/m)	Limit (dBuV/m)	Margin (dB)	Remark
1	4880.000	35.73	4.21	39.94	74.00	-34.06	peak
2	7320.000	35.42	10.44	45.86	74.00	-28.14	peak

Note:1.Result (dBuV/m) = Correct Factor (dB/m) + Reading(dBuV).

2.Correction factor (dB/m) = Antenna Factor (dB/m) + Cable loss (dB) – Pre-Amplifier gain (dB).

3.When the peak results are less than average limit, so not need to evaluate the average.

Standard:	FCC Part 15.247	Test Distance:	3 m
Test item:	Harmonic		
Frequency:	2440 MHz		
Mode:	Mode 2		
Ant.Polar.:	Vertical		

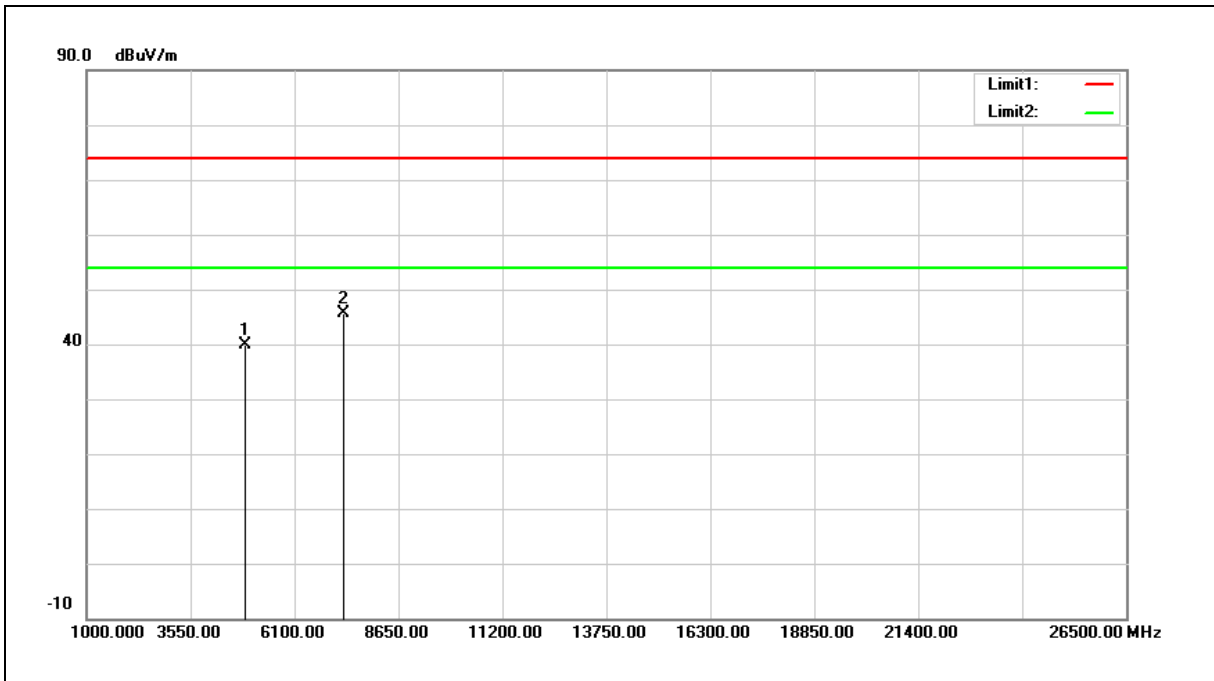

No.	Frequency (MHz)	Reading (dBuV)	Correct Factor (dB/m)	Result (dBuV/m)	Limit (dBuV/m)	Margin (dB)	Remark
1	4880.000	35.59	4.21	39.80	74.00	-34.20	peak
2	7320.000	35.18	10.44	45.62	74.00	-28.38	peak

- Note:1.Result (dBuV/m) = Correct Factor (dB/m) + Reading(dBuV).
 2.Correction factor (dB/m) = Antenna Factor (dB/m) + Cable loss (dB) – Pre-Amplifier gain (dB).
 3.When the peak results are less than average limit, so not need to evaluate the average.

Standard:	FCC Part 15.247	Test Distance:	3 m
Test item:	Harmonic		
Frequency:	2480 MHz		
Mode:	Mode 2		
Ant.Polar.:	Horizontal		

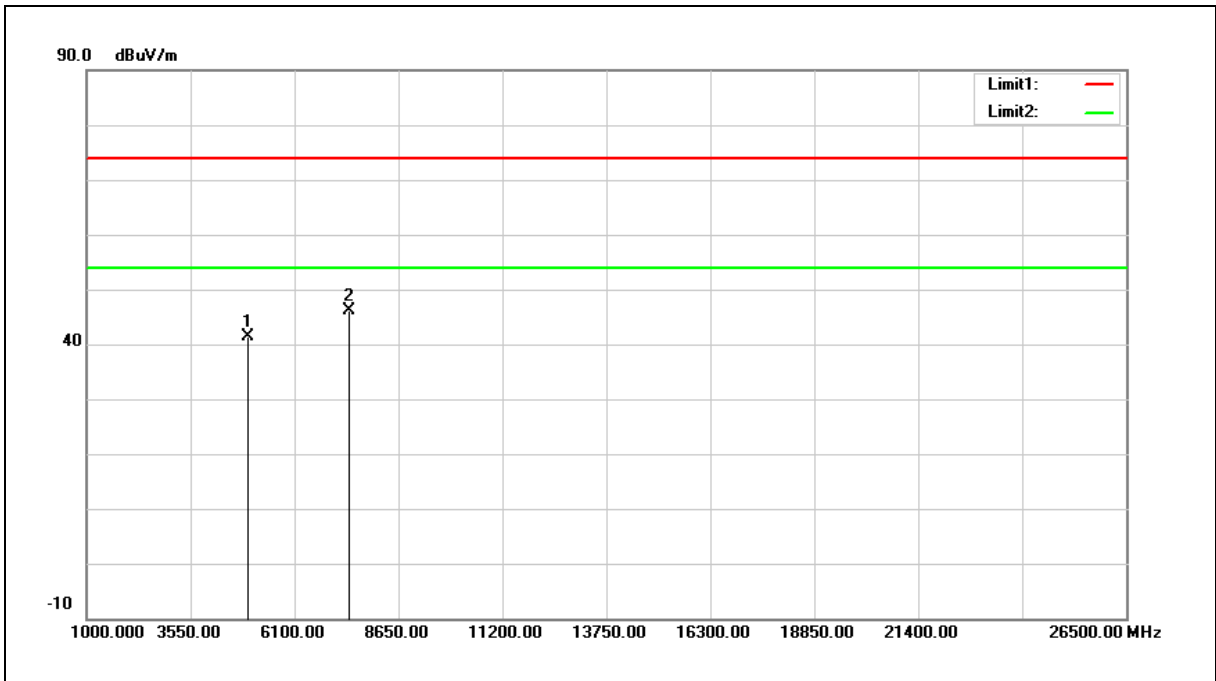

No.	Frequency (MHz)	Reading (dBuV)	Correct Factor (dB/m)	Result (dBuV/m)	Limit (dBuV/m)	Margin (dB)	Remark
1	4960.000	36.82	4.47	41.29	74.00	-32.71	peak
2	7440.000	35.25	10.81	46.06	74.00	-27.94	peak

Note:1.Result (dBuV/m) = Correct Factor (dB/m) + Reading(dBuV).

2.Correction factor (dB/m) = Antenna Factor (dB/m) + Cable loss (dB) – Pre-Amplifier gain (dB).

3.When the peak results are less than average limit, so not need to evaluate the average.

Standard:	FCC Part 15.247	Test Distance:	3 m
Test item:	Harmonic		
Frequency:	2480 MHz		
Mode:	Mode 2		
Ant.Polar.:	Vertical		

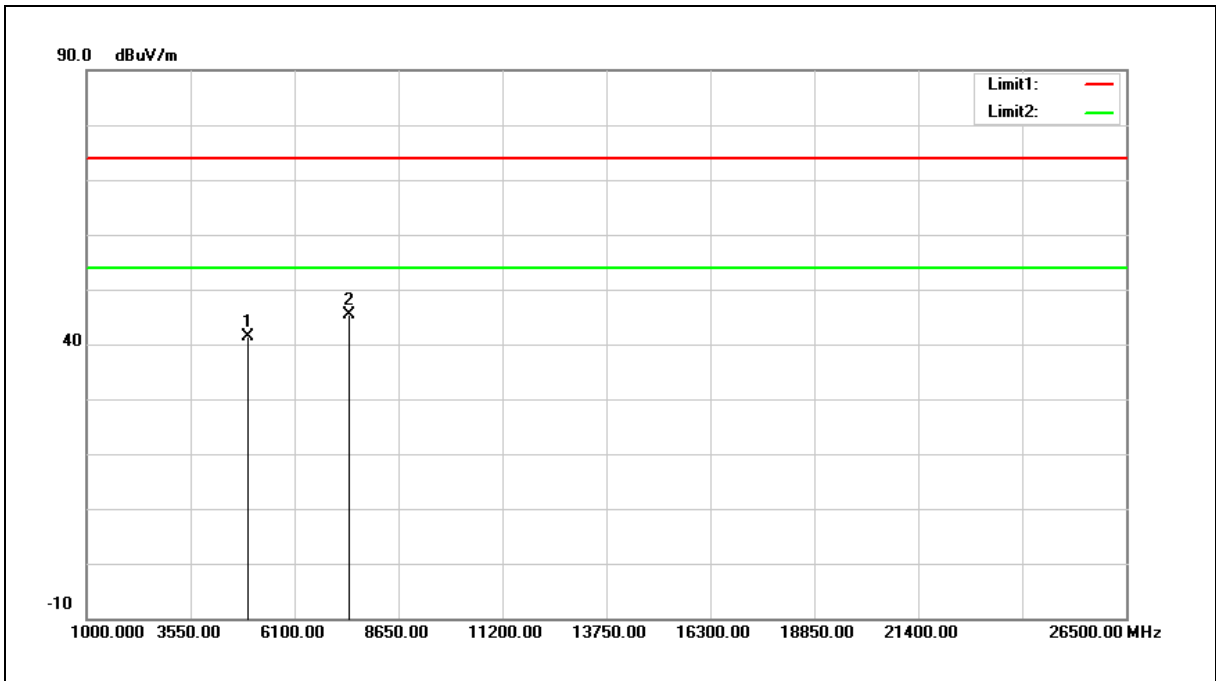

No.	Frequency (MHz)	Reading (dBuV)	Correct Factor (dB/m)	Result (dBuV/m)	Limit (dBuV/m)	Margin (dB)	Remark
1	4960.000	36.80	4.47	41.27	74.00	-32.73	peak
2	7440.000	34.55	10.81	45.36	74.00	-28.64	peak

Note:1.Result (dBuV/m) = Correct Factor (dB/m) + Reading(dBuV).

2.Correction factor (dB/m) = Antenna Factor (dB/m) + Cable loss (dB) – Pre-Amplifier gain (dB).

3.When the peak results are less than average limit, so not need to evaluate the average.

Standard:	FCC Part 15.247	Test Distance:	3 m
Test item:	Harmonic		
Frequency:	2402 MHz		
Mode:	Mode 4		
Ant.Polar.:	Horizontal		

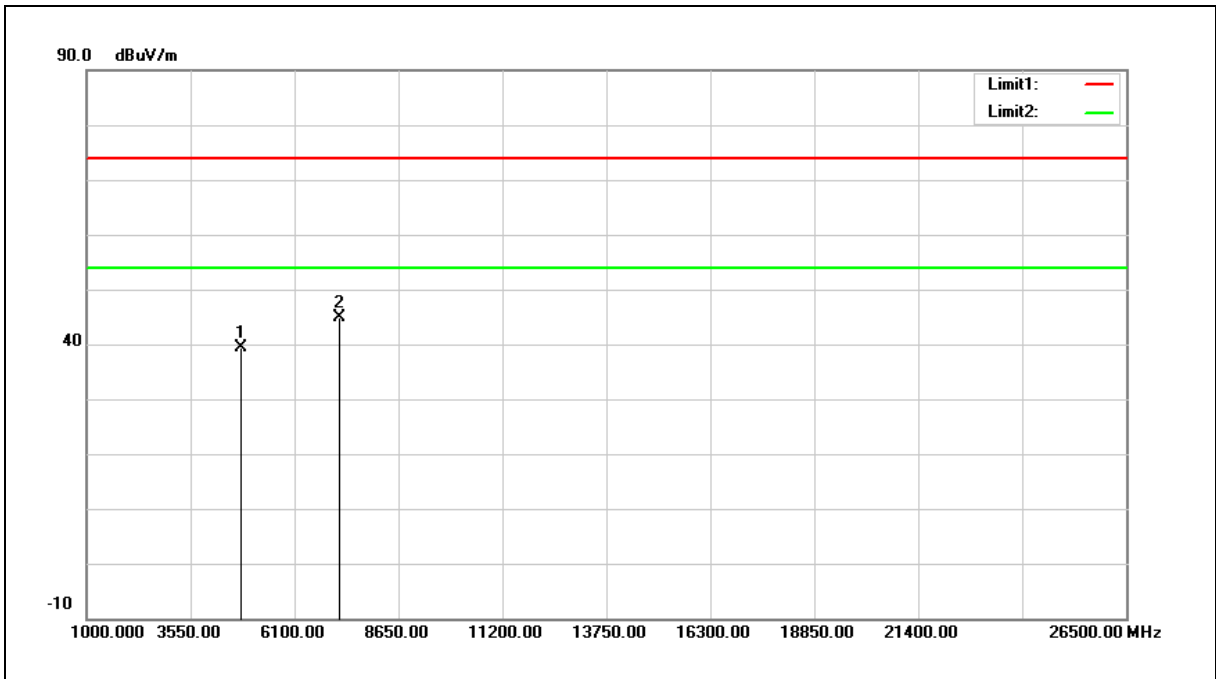

No.	Frequency (MHz)	Reading (dBuV)	Correct Factor (dB/m)	Result (dBuV/m)	Limit (dBuV/m)	Margin (dB)	Remark
1	4804.000	35.31	3.97	39.28	74.00	-34.72	peak
2	7206.000	34.67	10.10	44.77	74.00	-29.23	peak

Note:1.Result (dBuV/m) = Correct Factor (dB/m) + Reading(dBuV).

2.Correction factor (dB/m) = Antenna Factor (dB/m) + Cable loss (dB) – Pre-Amplifier gain (dB).

3.When the peak results are less than average limit, so not need to evaluate the average.

Standard:	FCC Part 15.247	Test Distance:	3 m
Test item:	Harmonic		
Frequency:	2402 MHz		
Mode:	Mode 4		
Ant.Polar.:	Vertical		

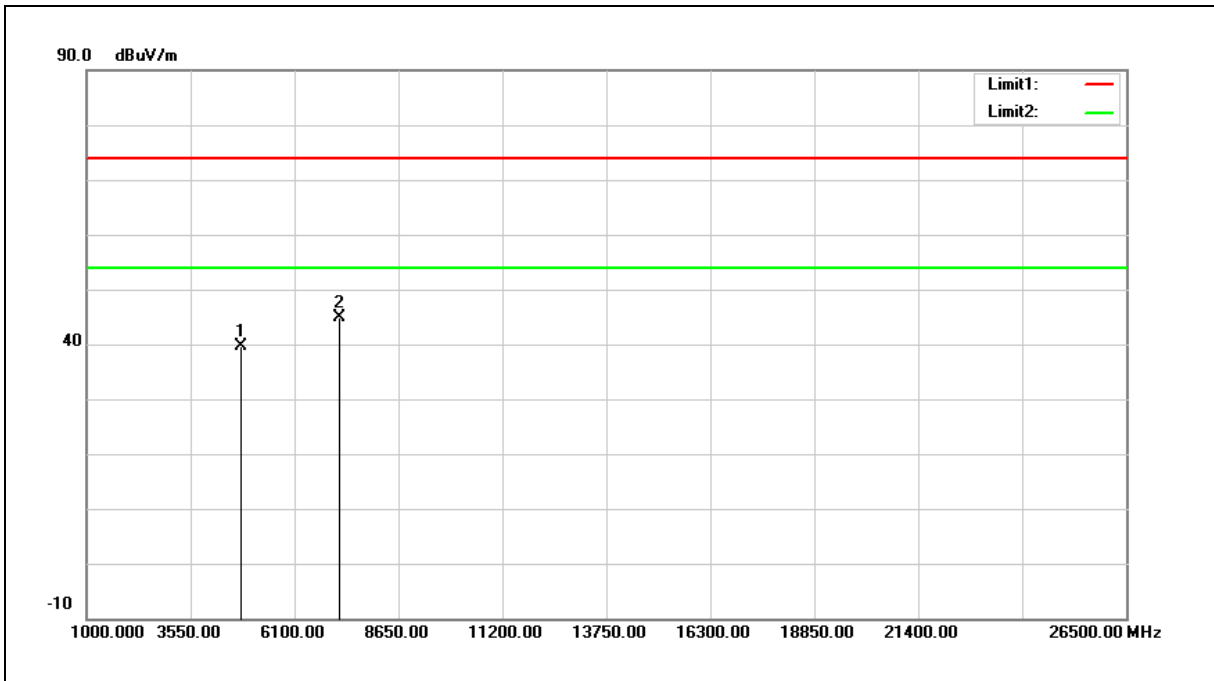

No.	Frequency (MHz)	Reading (dBuV)	Correct Factor (dB/m)	Result (dBuV/m)	Limit (dBuV/m)	Margin (dB)	Remark
1	4804.000	35.59	3.97	39.56	74.00	-34.44	peak
2	7206.000	34.87	10.10	44.97	74.00	-29.03	peak

Note:1.Result (dBuV/m) = Correct Factor (dB/m) + Reading(dBuV).

2.Correction factor (dB/m) = Antenna Factor (dB/m) + Cable loss (dB) – Pre-Amplifier gain (dB).

3.When the peak results are less than average limit, so not need to evaluate the average.

Standard:	FCC Part 15.247	Test Distance:	3 m
Test item:	Harmonic		
Frequency:	2440 MHz		
Mode:	Mode 4		
Ant.Polar.:	Horizontal		

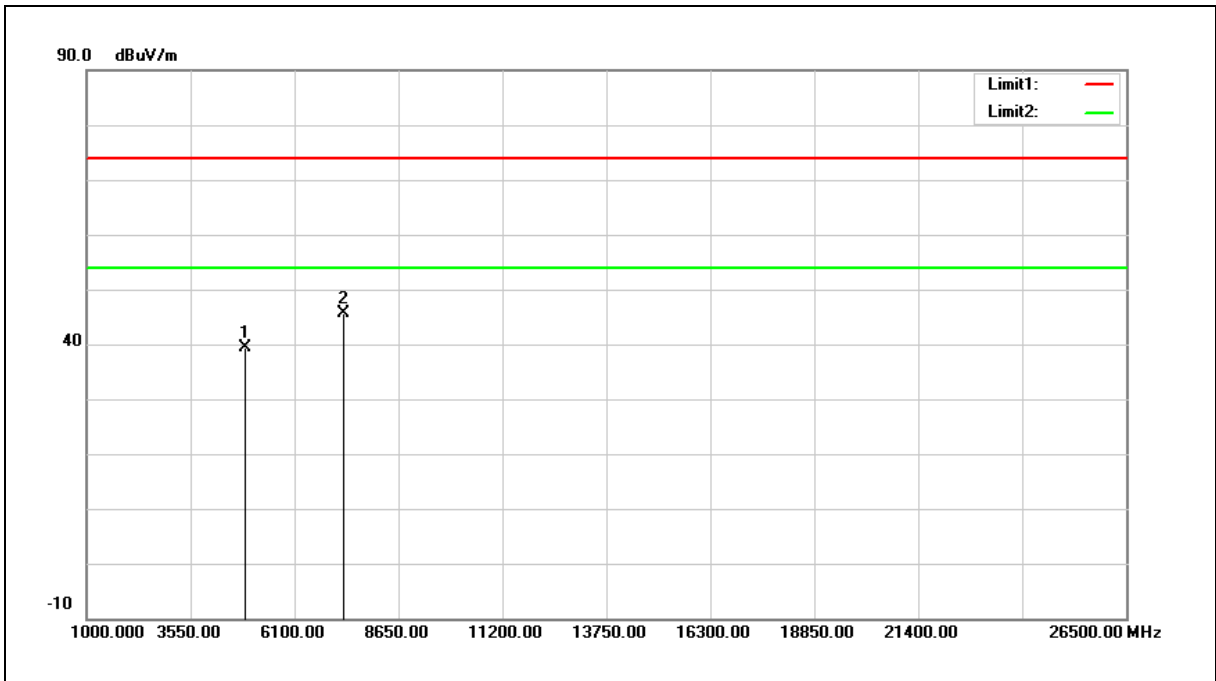

No.	Frequency (MHz)	Reading (dBuV)	Correct Factor (dB/m)	Result (dBuV/m)	Limit (dBuV/m)	Margin (dB)	Remark
1	4880.000	35.12	4.21	39.33	74.00	-34.67	peak
2	7320.000	35.28	10.44	45.72	74.00	-28.28	peak

Note:1.Result (dBuV/m) = Correct Factor (dB/m) + Reading(dBuV).

2.Correction factor (dB/m) = Antenna Factor (dB/m) + Cable loss (dB) – Pre-Amplifier gain (dB).

3.When the peak results are less than average limit, so not need to evaluate the average.

Standard:	FCC Part 15.247	Test Distance:	3 m
Test item:	Harmonic		
Frequency:	2440 MHz		
Mode:	Mode 4		
Ant.Polar.:	Vertical		

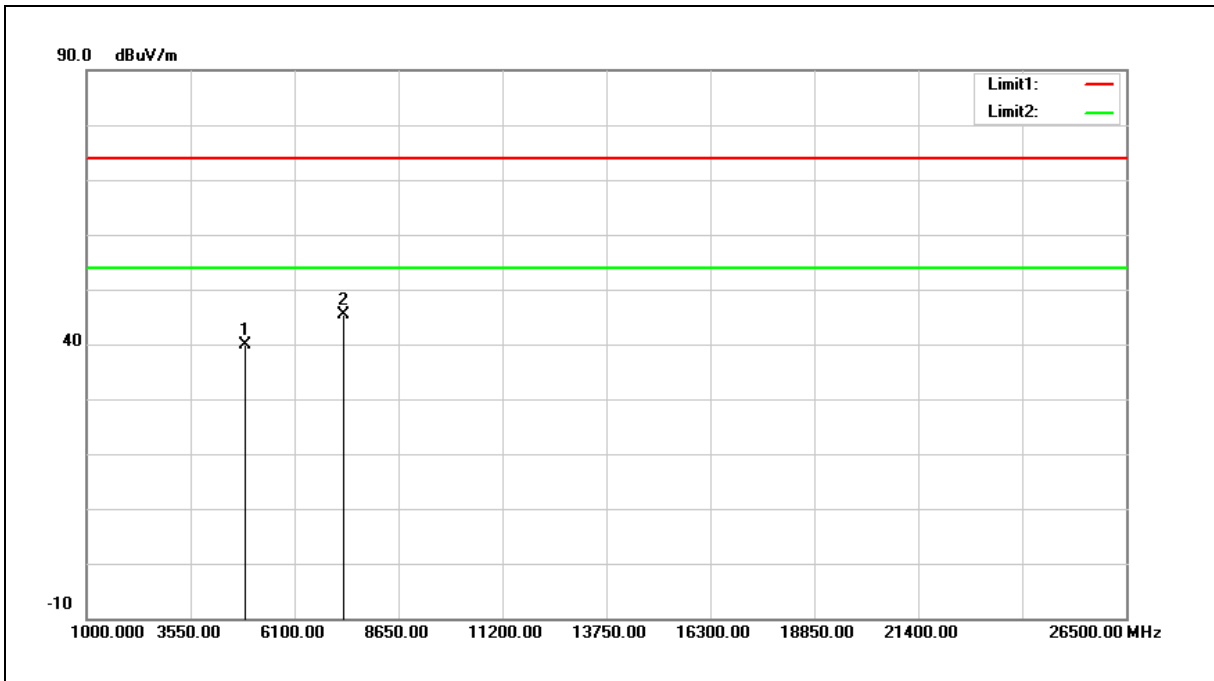

No.	Frequency (MHz)	Reading (dBuV)	Correct Factor (dB/m)	Result (dBuV/m)	Limit (dBuV/m)	Margin (dB)	Remark
1	4880.000	35.56	4.21	39.77	74.00	-34.23	peak
2	7320.000	34.85	10.44	45.29	74.00	-28.71	peak

Note:1.Result (dBuV/m) = Correct Factor (dB/m) + Reading(dBuV).

2.Correction factor (dB/m) = Antenna Factor (dB/m) + Cable loss (dB) – Pre-Amplifier gain (dB).

3.When the peak results are less than average limit, so not need to evaluate the average.

Standard:	FCC Part 15.247	Test Distance:	3 m
Test item:	Harmonic		
Frequency:	2480 MHz		
Mode:	Mode 4		
Ant.Polar.:	Horizontal		

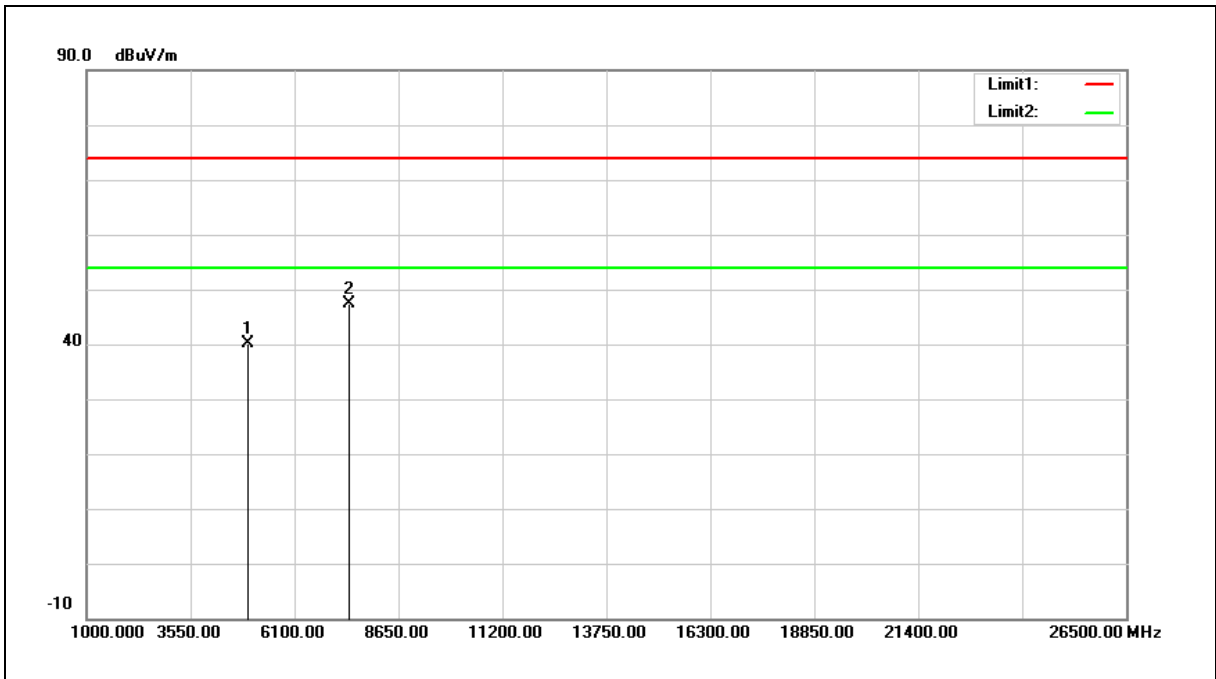

No.	Frequency (MHz)	Reading (dBuV)	Correct Factor (dB/m)	Result (dBuV/m)	Limit (dBuV/m)	Margin (dB)	Remark
1	4960.000	35.54	4.47	40.01	74.00	-33.99	peak
2	7440.000	36.54	10.81	47.35	74.00	-26.65	peak

- Note:1.Result (dBuV/m) = Correct Factor (dB/m) + Reading(dBuV).
 2.Correction factor (dB/m) = Antenna Factor (dB/m) + Cable loss (dB) – Pre-Amplifier gain (dB).
 3.When the peak results are less than average limit, so not need to evaluate the average.

Standard:	FCC Part 15.247	Test Distance:	3 m
Test item:	Harmonic		
Frequency:	2480 MHz		
Mode:	Mode 4		
Ant.Polar.:	Vertical		

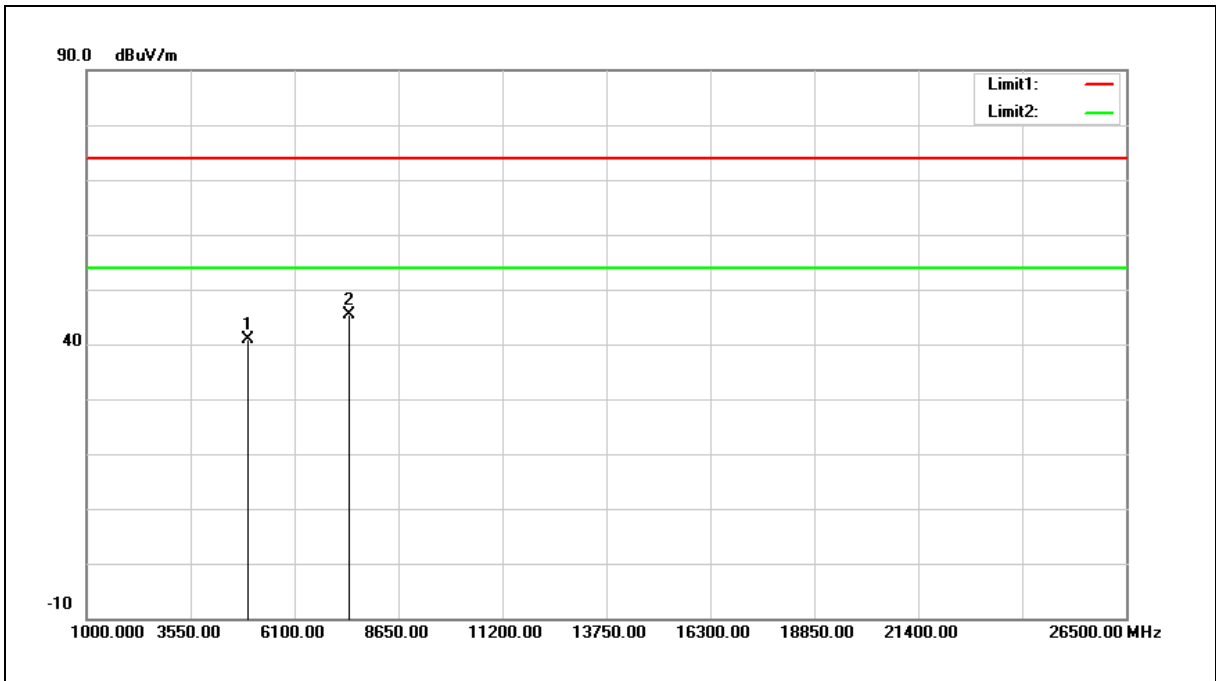

No.	Frequency (MHz)	Reading (dBuV)	Correct Factor (dB/m)	Result (dBuV/m)	Limit (dBuV/m)	Margin (dB)	Remark
1	4960.000	36.35	4.47	40.82	74.00	-33.18	peak
2	7440.000	34.47	10.81	45.28	74.00	-28.72	peak

Note:1.Result (dBuV/m) = Correct Factor (dB/m) + Reading(dBuV).

2.Correction factor (dB/m) = Antenna Factor (dB/m) + Cable loss (dB) – Pre-Amplifier gain (dB).

3.When the peak results are less than average limit, so not need to evaluate the average.

Band Edge

Peak

Standard:	FCC Part 15.247	Test Distance:	3 m
Test item:	Band edge		
Frequency:	2402 MHz		
Mode:	Mode 2		
Ant.Polar.:	Horizontal		

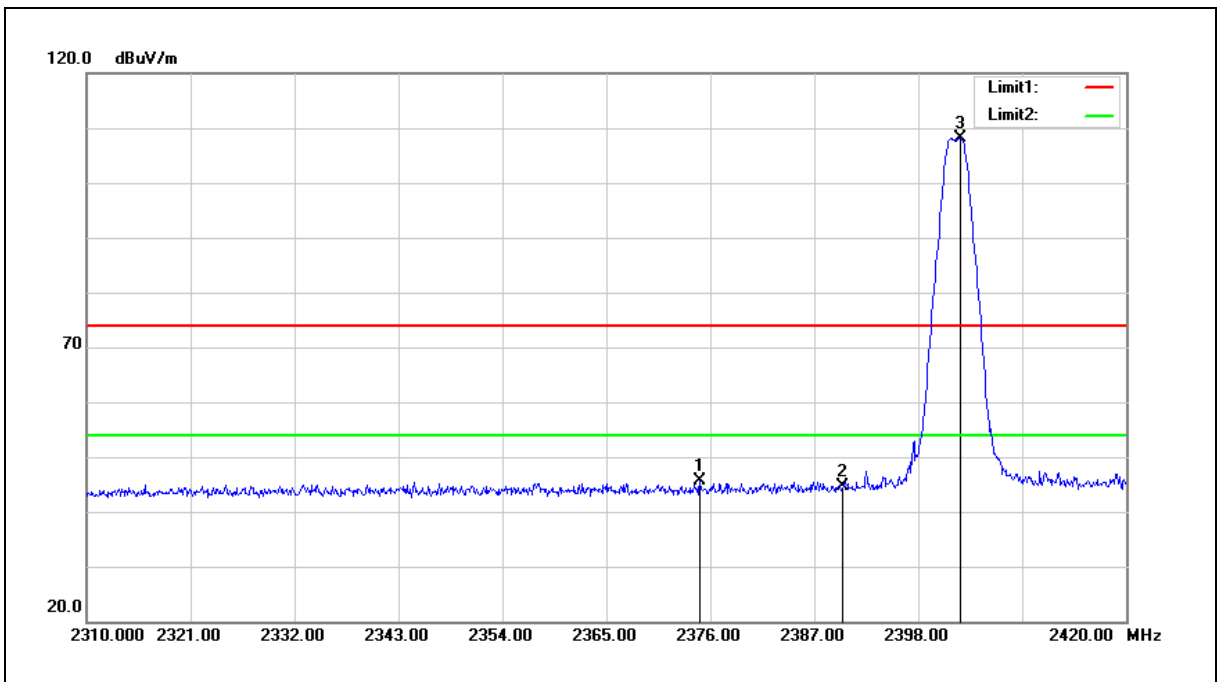

No.	Frequency (MHz)	Reading (dBuV)	Correct Factor (dB/m)	Result (dBuV/m)	Limit (dBuV/m)	Margin (dB)	Remark
1	2374.900	47.91	-2.27	45.64	74.00	-28.36	peak
2	2390.000	46.74	-2.21	44.53	74.00	-29.47	peak
3	2402.510	110.38	-2.16	108.22	74.00	34.22	peak

Note:1.Result (dBuV/m) = Correct Factor (dB/m) + Reading(dBuV).

2.Correction factor (dB/m) = Antenna Factor (dB/m) + Cable loss (dB) – Pre-Amplifier gain (dB).

3.When the peak results are less than average limit, so not need to evaluate the average.

Standard:	FCC Part 15.247	Test Distance:	3 m
Test item:	Band edge		
Frequency:	2402 MHz		
Mode:	Mode 2		
Ant.Polar.:	Vertical		

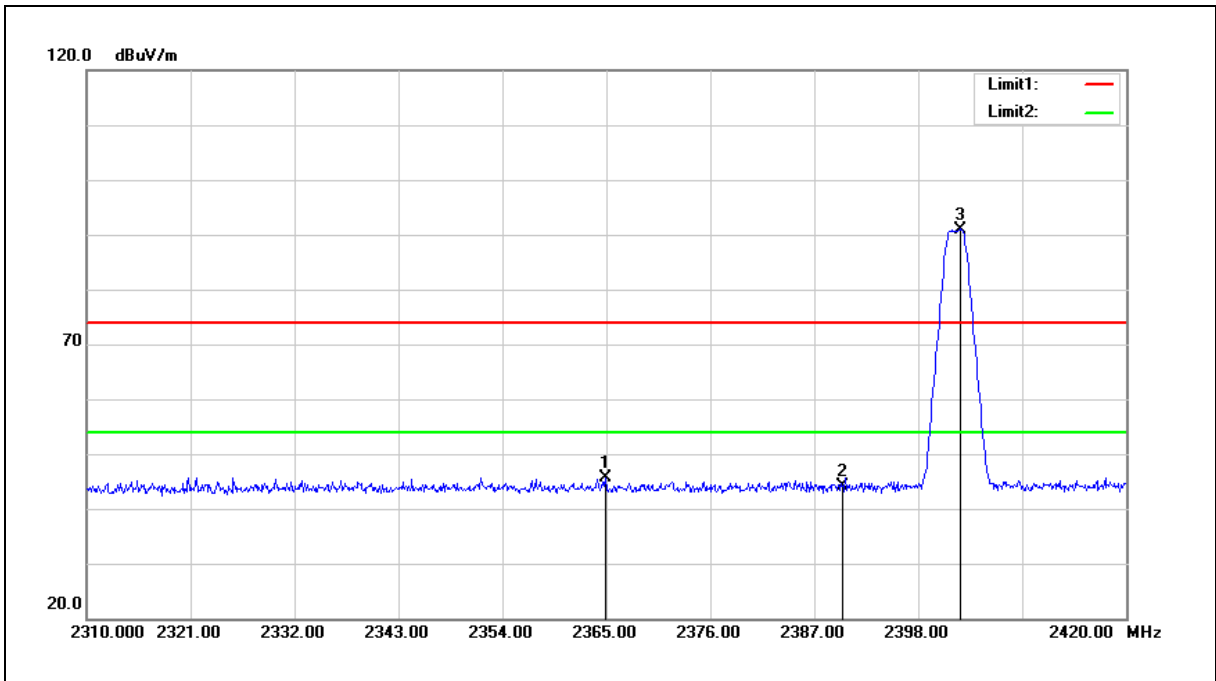

No.	Frequency (MHz)	Reading (dBuV)	Correct Factor (dB/m)	Result (dBuV/m)	Limit (dBuV/m)	Margin (dB)	Remark
1	2364.890	48.00	-2.31	45.69	74.00	-28.31	peak
2	2390.000	46.27	-2.21	44.06	74.00	-29.94	peak
3	2402.400	93.16	-2.16	91.00	74.00	17.00	peak

Note:1.Result (dBuV/m) = Correct Factor (dB/m) + Reading(dBuV).

2.Correction factor (dB/m) = Antenna Factor (dB/m) + Cable loss (dB) – Pre-Amplifier gain (dB).

3.When the peak results are less than average limit, so not need to evaluate the average.

Standard:	FCC Part 15.247	Test Distance:	3 m
Test item:	Band edge		
Mode:	Mode 2		
Ant.Polar.:	Horizontal		
Description:			

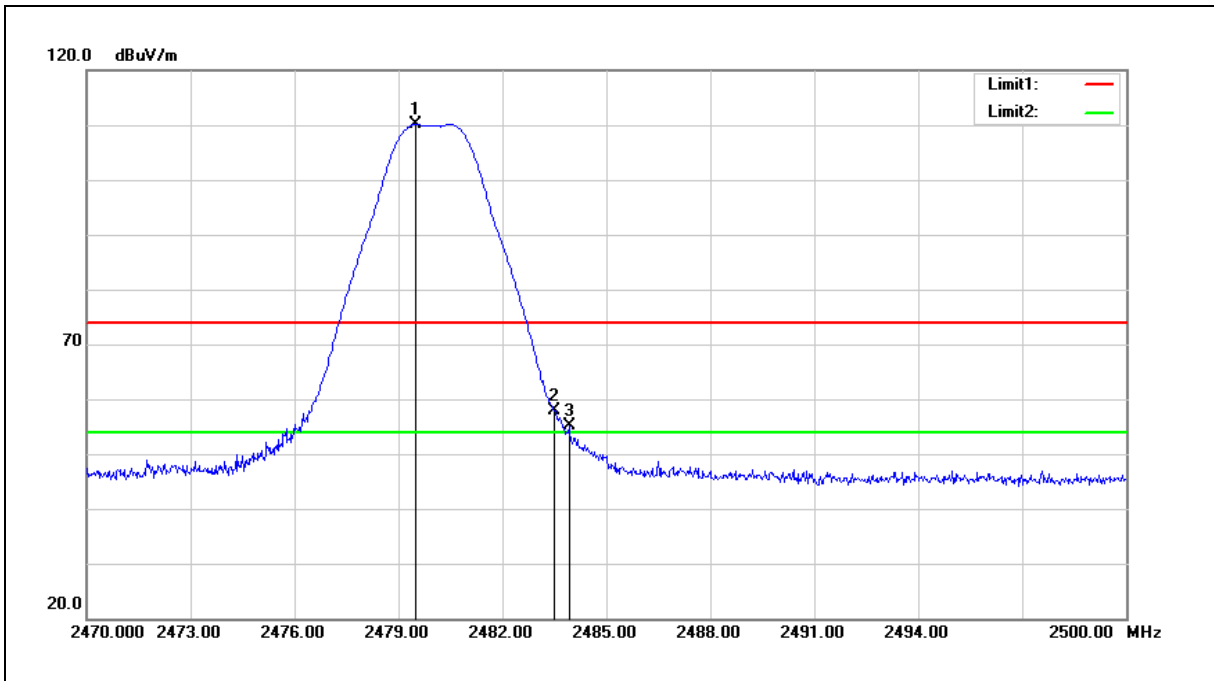

No.	Frequency (MHz)	Reading (dBuV)	Correct Factor (dB/m)	Result (dBuV/m)	Limit (dBuV/m)	Margin (dB)	Remark
1	2479.480	112.05	-1.88	110.17	74.00	36.17	peak
2	2483.500	59.65	-1.87	57.78	74.00	-16.22	peak
3	2483.920	56.88	-1.87	55.01	74.00	-18.99	peak

Note:1.Result (dBuV/m) = Correct Factor (dB/m) + Reading(dBuV).

2.Correction factor (dB/m) = Antenna Factor (dB/m) + Cable loss (dB) – Pre-Amplifier gain (dB).

3.When the peak results are less than average limit, so not need to evaluate the average.

Standard:	FCC Part 15.247	Test Distance:	3 m
Test item:	Band edge		
Frequency:	2480 MHz		
Mode:	Mode 2		
Ant.Polar.:	Vertical		

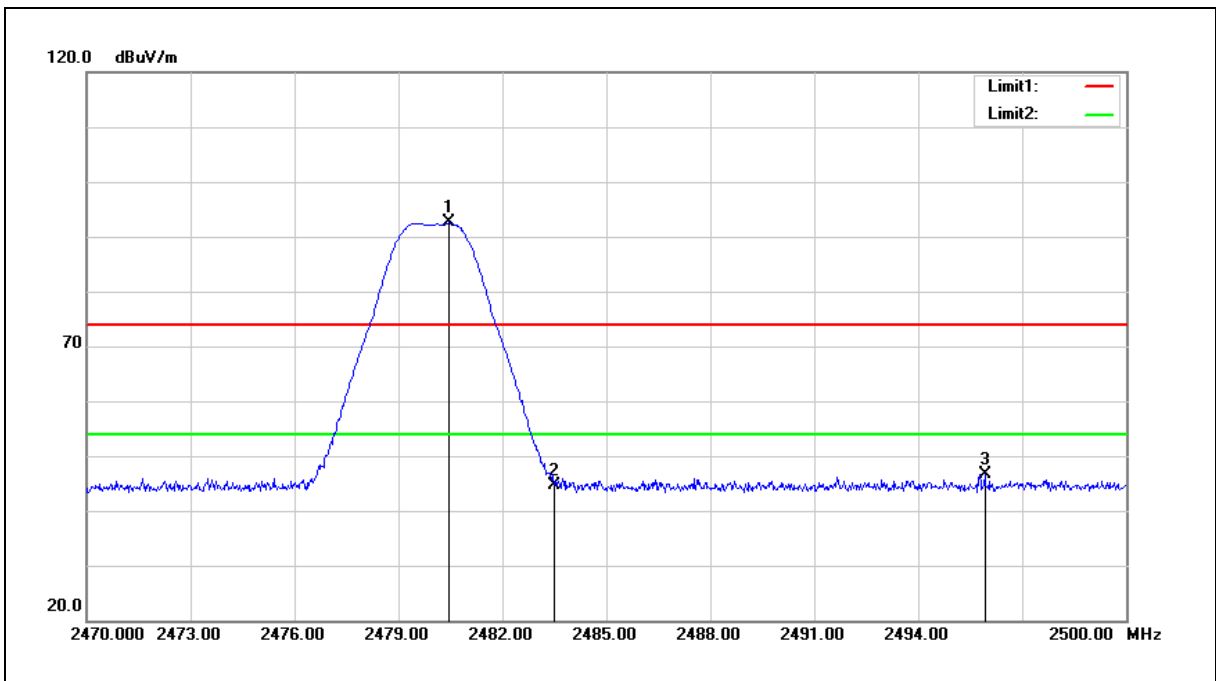

No.	Frequency (MHz)	Reading (dBuV)	Correct Factor (dB/m)	Result (dBuV/m)	Limit (dBuV/m)	Margin (dB)	Remark
1	2480.470	94.39	-1.87	92.52	74.00	18.52	peak
2	2483.500	46.62	-1.87	44.75	74.00	-29.25	peak
3	2495.920	48.44	-1.81	46.63	74.00	-27.37	peak

Note:1.Result (dBuV/m) = Correct Factor (dB/m) + Reading(dBuV).

2.Correction factor (dB/m) = Antenna Factor (dB/m) + Cable loss (dB) – Pre-Amplifier gain (dB).

3.When the peak results are less than average limit, so not need to evaluate the average.

Standard:	FCC Part 15.247	Test Distance:	3 m
Test item:	Band edge		
Frequency:	2402 MHz		
Mode:	Mode 4		
Ant.Polar.:	Horizontal		

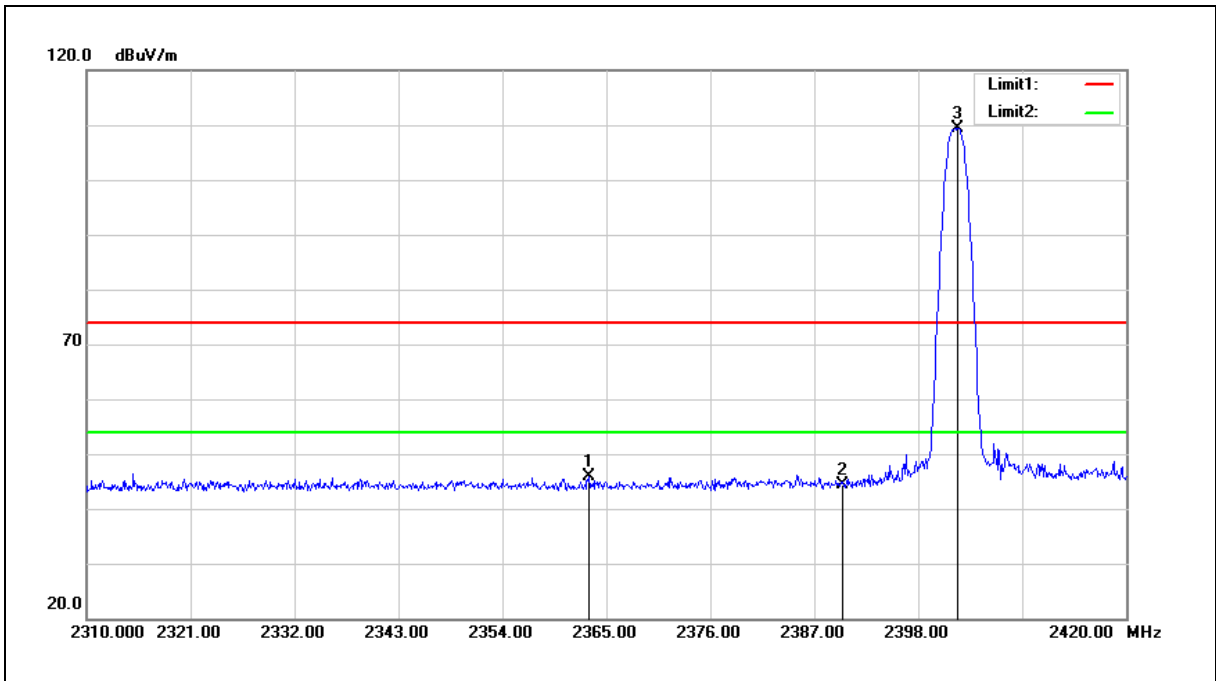

No.	Frequency (MHz)	Reading (dBuV)	Correct Factor (dB/m)	Result (dBuV/m)	Limit (dBuV/m)	Margin (dB)	Remark
1	2363.130	48.15	-2.31	45.84	74.00	-28.16	peak
2	2390.000	46.62	-2.21	44.41	74.00	-29.59	peak
3	2402.180	111.56	-2.16	109.40	74.00	35.40	peak

Note:1.Result (dBuV/m) = Correct Factor (dB/m) + Reading(dBuV).

2.Correction factor (dB/m) = Antenna Factor (dB/m) + Cable loss (dB) – Pre-Amplifier gain (dB).

3.When the peak results are less than average limit, so not need to evaluate the average.

Standard:	FCC Part 15.247	Test Distance:	3 m
Test item:	Band edge		
Frequency:	2402 MHz		
Mode:	Mode 4		
Ant.Polar.:	Vertical		

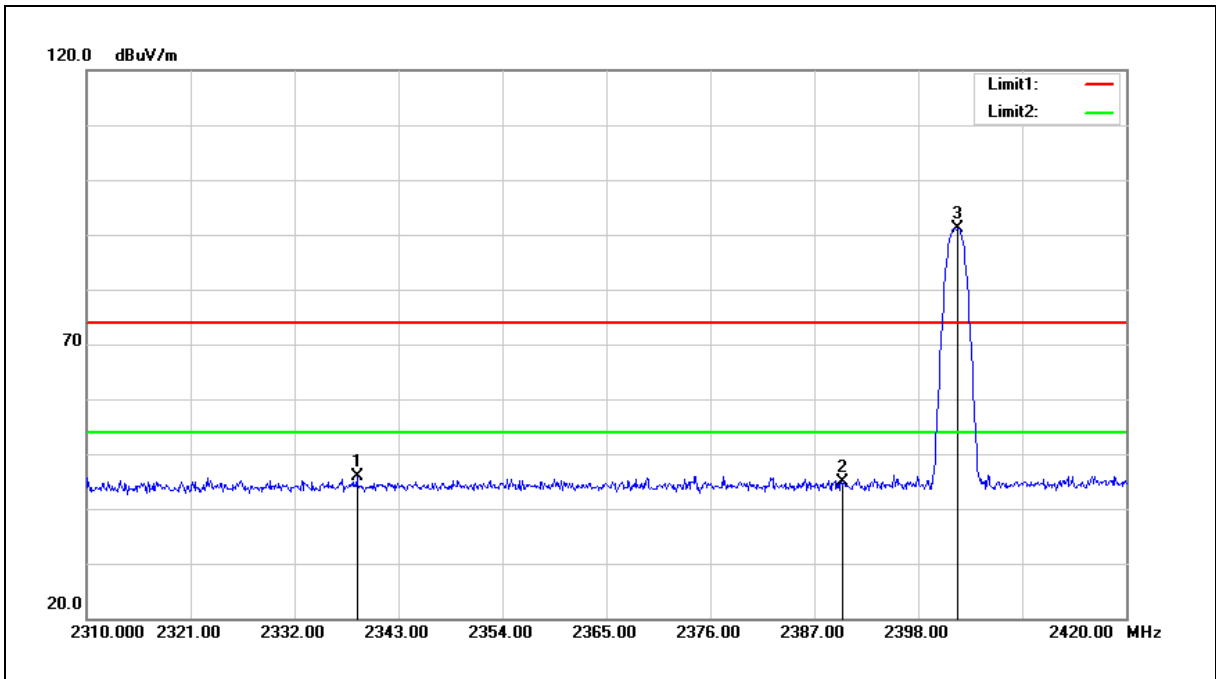

No.	Frequency (MHz)	Reading (dBuV)	Correct Factor (dB/m)	Result (dBuV/m)	Limit (dBuV/m)	Margin (dB)	Remark
1	2338.600	48.37	-2.39	45.98	74.00	-28.02	peak
2	2390.000	46.98	-2.21	44.77	74.00	-29.23	peak
3	2402.180	93.25	-2.16	91.09	74.00	17.09	peak

Note:1.Result (dBuV/m) = Correct Factor (dB/m) + Reading(dBuV).

2.Correction factor (dB/m) = Antenna Factor (dB/m) + Cable loss (dB) – Pre-Amplifier gain (dB).

3.When the peak results are less than average limit, so not need to evaluate the average.

Standard:	FCC Part 15.247	Test Distance:	3 m
Test item:	Band edge		
Frequency:	2480 MHz		
Mode:	Mode 4		
Ant.Polar.:	Horizontal		

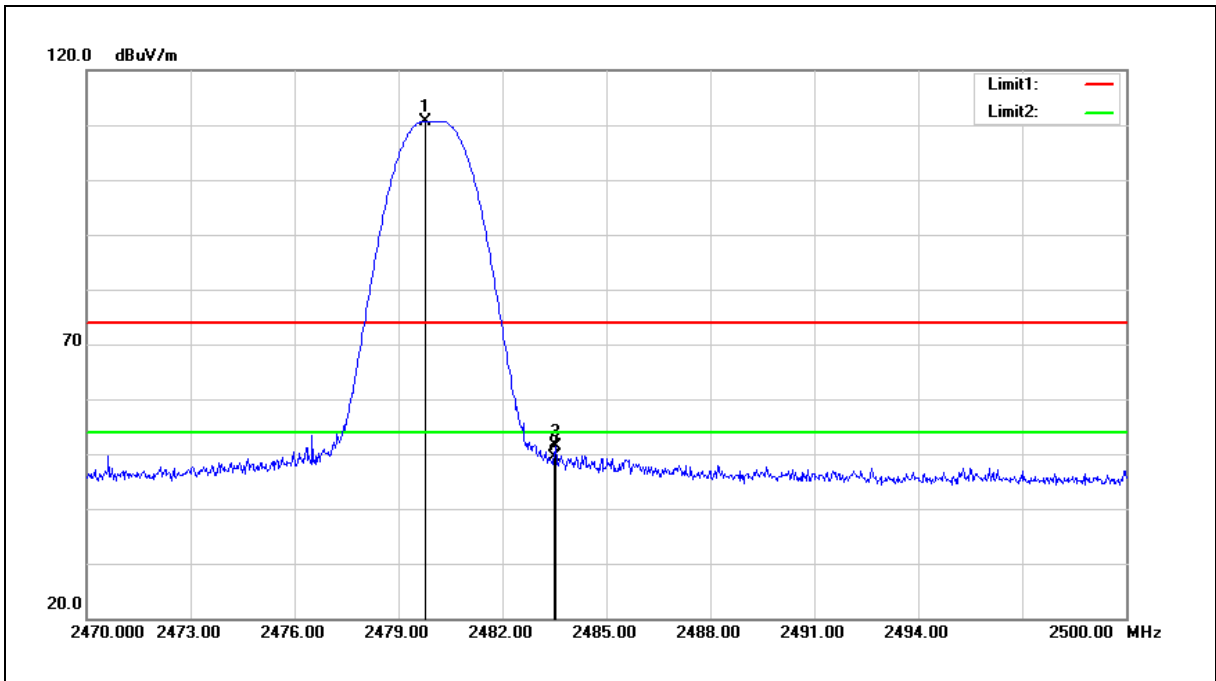

No.	Frequency (MHz)	Reading (dBuV)	Correct Factor (dB/m)	Result (dBuV/m)	Limit (dBuV/m)	Margin (dB)	Remark
1	2479.780	112.61	-1.88	110.73	74.00	36.73	peak
2	2483.500	51.20	-1.87	49.33	74.00	-24.67	peak
3	2483.530	53.16	-1.87	51.29	74.00	-22.71	peak

Note:1.Result (dBuV/m) = Correct Factor (dB/m) + Reading(dBuV).

2.Correction factor (dB/m) = Antenna Factor (dB/m) + Cable loss (dB) – Pre-Amplifier gain (dB).

3.When the peak results are less than average limit, so not need to evaluate the average.

Standard:	FCC Part 15.247	Test Distance:	3 m
Test item:	Band edge		
Frequency:	2480 MHz		
Mode:	Mode 4		
Ant.Polar.:	Vertical		

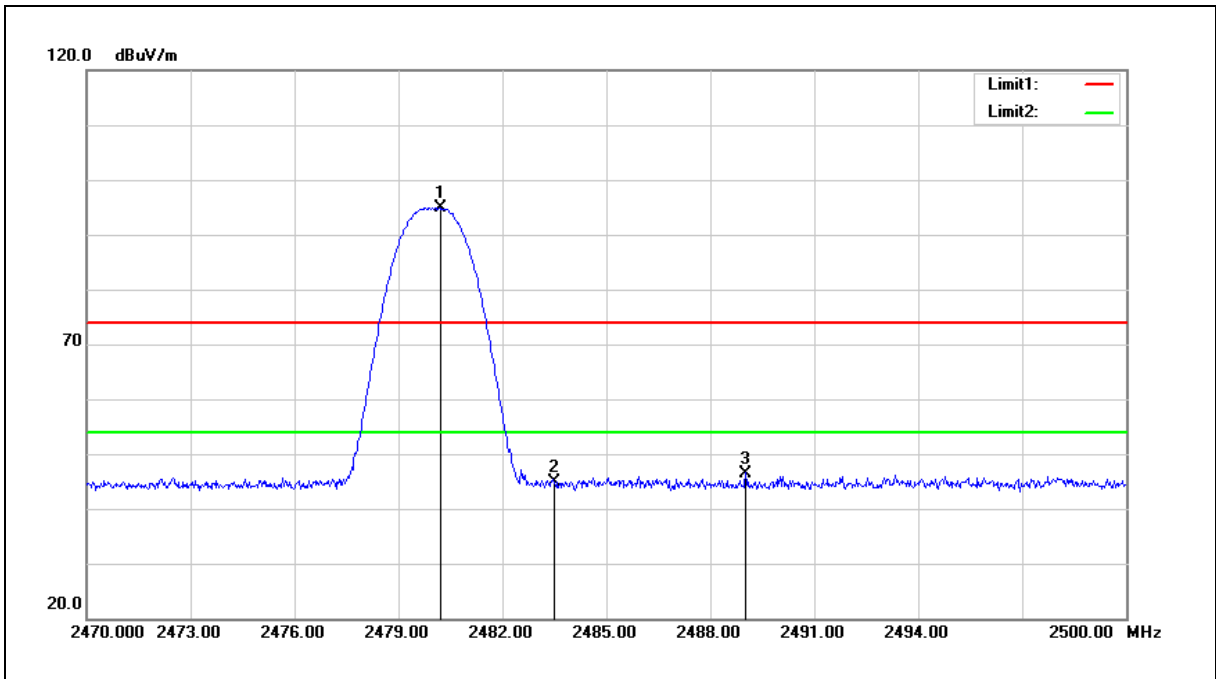

No.	Frequency (MHz)	Reading (dBuV)	Correct Factor (dB/m)	Result (dBuV/m)	Limit (dBuV/m)	Margin (dB)	Remark
1	2480.200	96.79	-1.88	94.91	74.00	20.91	peak
2	2483.500	46.68	-1.87	44.81	74.00	-29.19	peak
3	2489.020	48.34	-1.84	46.50	74.00	-27.50	peak

Note:1.Result (dBuV/m) = Correct Factor (dB/m) + Reading(dBuV).

2.Correction factor (dB/m) = Antenna Factor (dB/m) + Cable loss (dB) – Pre-Amplifier gain (dB).

3.When the peak results are less than average limit, so not need to evaluate the average.

Average

Standard:	FCC Part 15.247	Test Distance:	3 m
Test item:	Band edge		
Frequency:	2480 MHz		
Mode:	Mode 2		
Ant.Polar.:	Horizontal		

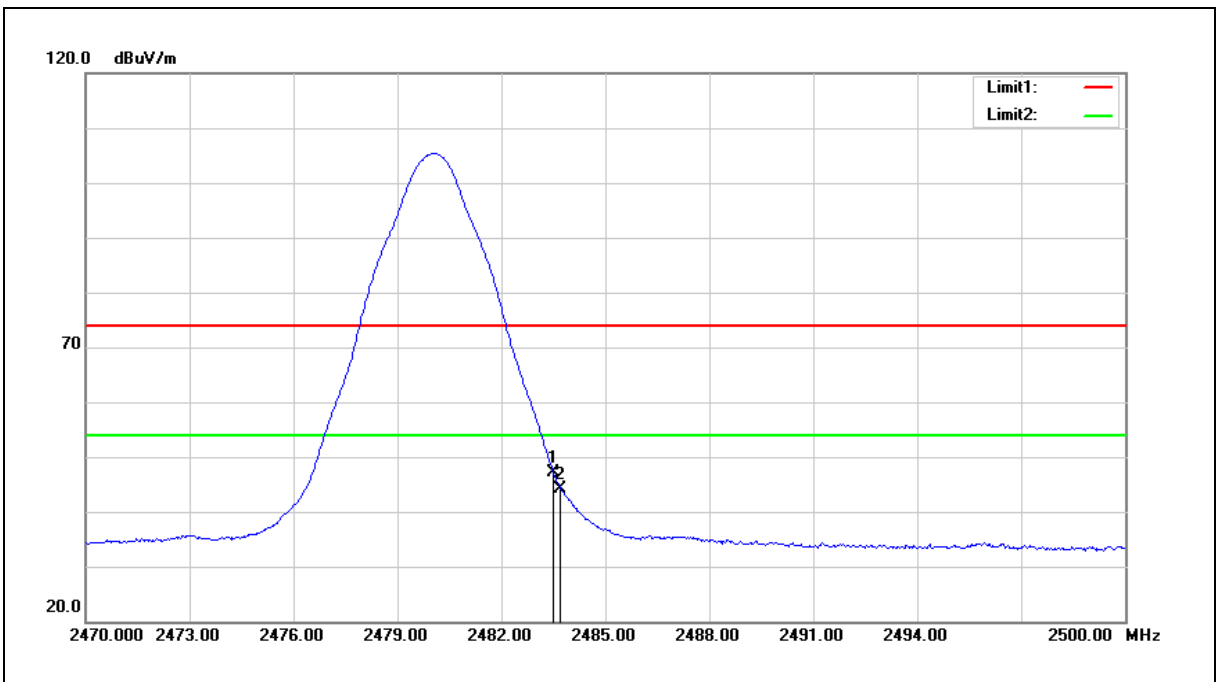

No.	Frequency (MHz)	Reading (dBuV)	Correct Factor (dB/m)	Result (dBuV/m)	Limit (dBuV/m)	Margin (dB)	Remark
1	2483.500	49.11	-1.87	47.24	54.00	-6.76	AVG
2	2483.710	46.12	-1.87	44.25	54.00	-9.75	AVG

- Note:1.Result (dBuV/m) = Correct Factor (dB/m) + Reading(dBuV).
- 2.Correction factor (dB/m) = Antenna Factor (dB/m) + Cable loss (dB) – Pre-Amplifier gain (dB).
- 3.When the peak results are less than average limit, so not need to evaluate the average.

Standard:	FCC Part 15.247	Test Distance:	3 m
Test item:	Band edge		
Frequency:	2480 MHz		
Mode:	Mode 2		
Ant.Polar.:	Vertical		

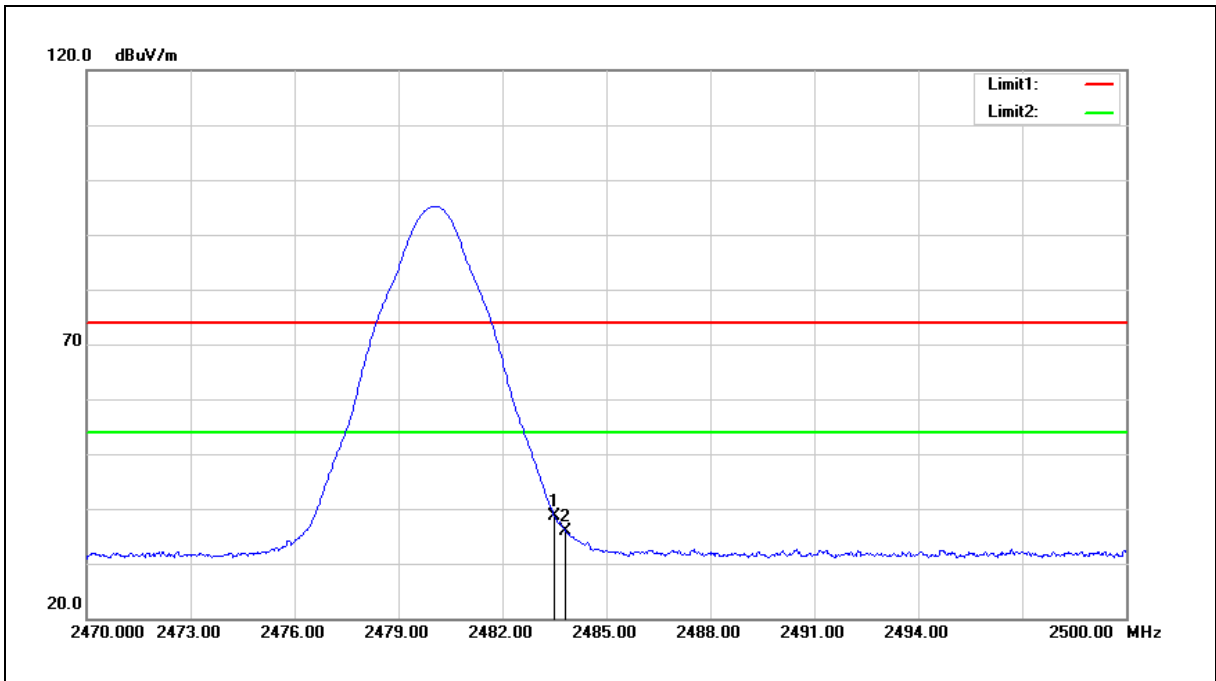

No.	Frequency (MHz)	Reading (dBuV)	Correct Factor (dB/m)	Result (dBuV/m)	Limit (dBuV/m)	Margin (dB)	Remark
1	2483.500	40.54	-1.87	38.67	54.00	-15.33	AVG
2	2483.830	37.70	-1.87	35.83	54.00	-18.17	AVG

- Note:1.Result (dBuV/m) = Correct Factor (dB/m) + Reading(dBuV).
- 2.Correction factor (dB/m) = Antenna Factor (dB/m) + Cable loss (dB) – Pre-Amplifier gain (dB).
- 3.When the peak results are less than average limit, so not need to evaluate the average.

FPC Dipole Antenna

Below 1 GHz

Standard:	FCC Part 15.247	Test Distance:	3 m
Frequency:	2480 MHz		
Mode:	Mode 1		
Ant.Polar.:	Horizontal		

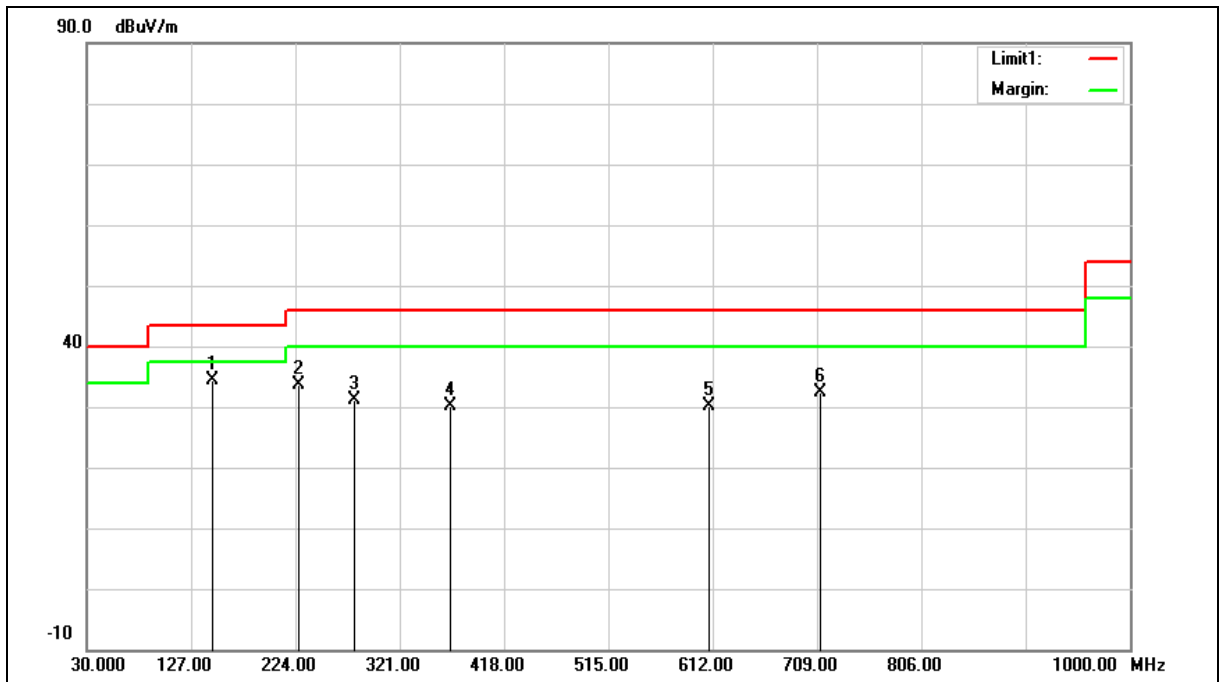

No.	Frequency (MHz)	Reading (dBuV)	Correct Factor (dB/m)	Result (dBuV/m)	Limit (dBuV/m)	Margin (dB)	Remark
1	147.3700	41.54	-7.10	34.44	43.50	-9.06	QP
2	226.9100	43.36	-9.62	33.74	46.00	-12.26	QP
3	279.2900	37.74	-6.69	31.05	46.00	-14.95	QP
4	367.5600	35.01	-4.95	30.06	46.00	-15.94	QP
5	608.1200	29.33	0.76	30.09	46.00	-15.91	QP
6	711.9100	29.67	2.69	32.36	46.00	-13.64	QP

Note:1.Result (dBuV/m) = Correct Factor (dB/m) + Reading(dBuV).

2.Correction factor (dB/m) = Antenna Factor (dB/m) + Cable loss (dB) – Pre-Amplifier gain (dB).

3.When the peak results are less than average limit, so not need to evaluate the average.

Standard:	FCC Part 15.247	Test Distance:	3 m
Frequency:	2480 MHz		
Mode:	Mode 1		
Ant.Polar.:	Vertical		

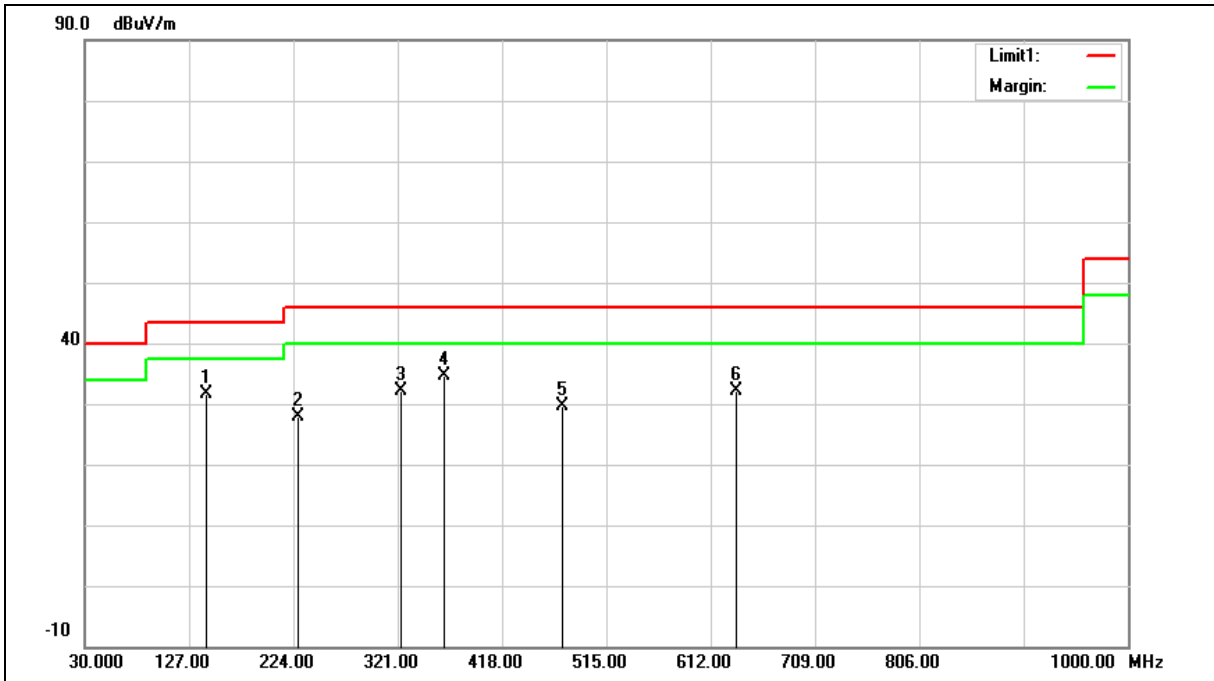

No.	Frequency (MHz)	Reading (dBuV)	Correct Factor (dB/m)	Result (dBuV/m)	Limit (dBuV/m)	Margin (dB)	Remark
1	143.4900	38.97	-7.38	31.59	43.50	-11.91	QP
2	227.8800	37.40	-9.61	27.79	46.00	-18.21	QP
3	323.9100	38.10	-5.94	32.16	46.00	-13.84	QP
4	363.6800	39.62	-5.09	34.53	46.00	-11.47	QP
5	474.2600	31.94	-2.42	29.52	46.00	-16.48	QP
6	635.2800	30.95	1.15	32.10	46.00	-13.90	QP

Note:1.Result (dBuV/m) = Correct Factor (dB/m) + Reading(dBuV).

2.Correction factor (dB/m) = Antenna Factor (dB/m) + Cable loss (dB) – Pre-Amplifier gain (dB).

3.When the peak results are less than average limit, so not need to evaluate the average.

Harmonic

Above 1 GHz

Standard:	FCC Part 15.247	Test Distance:	3 m
Test item:	Harmonic		
Frequency:	2402 MHz		
Mode:	Mode 2		
Ant.Polar.:	Horizontal		

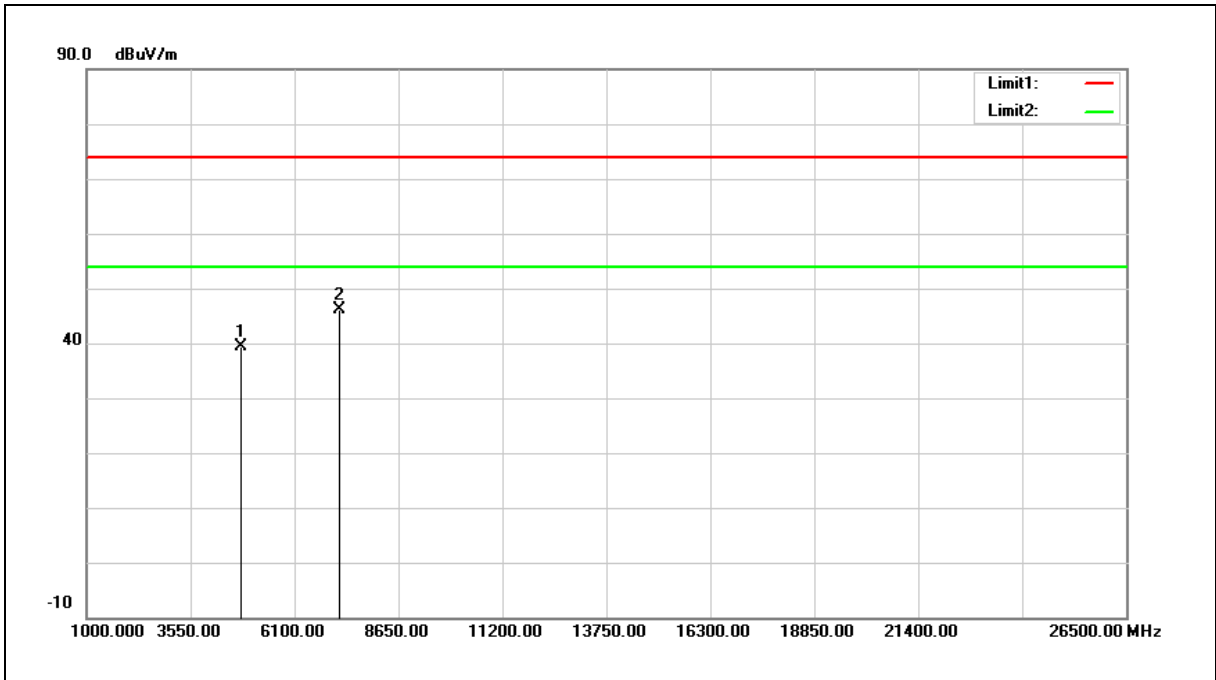

No.	Frequency (MHz)	Reading (dBuV)	Correct Factor (dB/m)	Result (dBuV/m)	Limit (dBuV/m)	Margin (dB)	Remark
1	4804.000	35.30	3.97	39.27	74.00	-34.73	peak
2	7206.000	36.01	10.10	46.11	74.00	-27.89	peak

Note:1.Result (dBuV/m) = Correct Factor (dB/m) + Reading(dBuV).

2.Correction factor (dB/m) = Antenna Factor (dB/m) + Cable loss (dB) – Pre-Amplifier gain (dB).

3.When the peak results are less than average limit, so not need to evaluate the average.

Standard:	FCC Part 15.247	Test Distance:	3 m
Test item:	Harmonic		
Frequency:	2402 MHz		
Mode:	Mode 2		
Ant.Polar.:	Vertical		

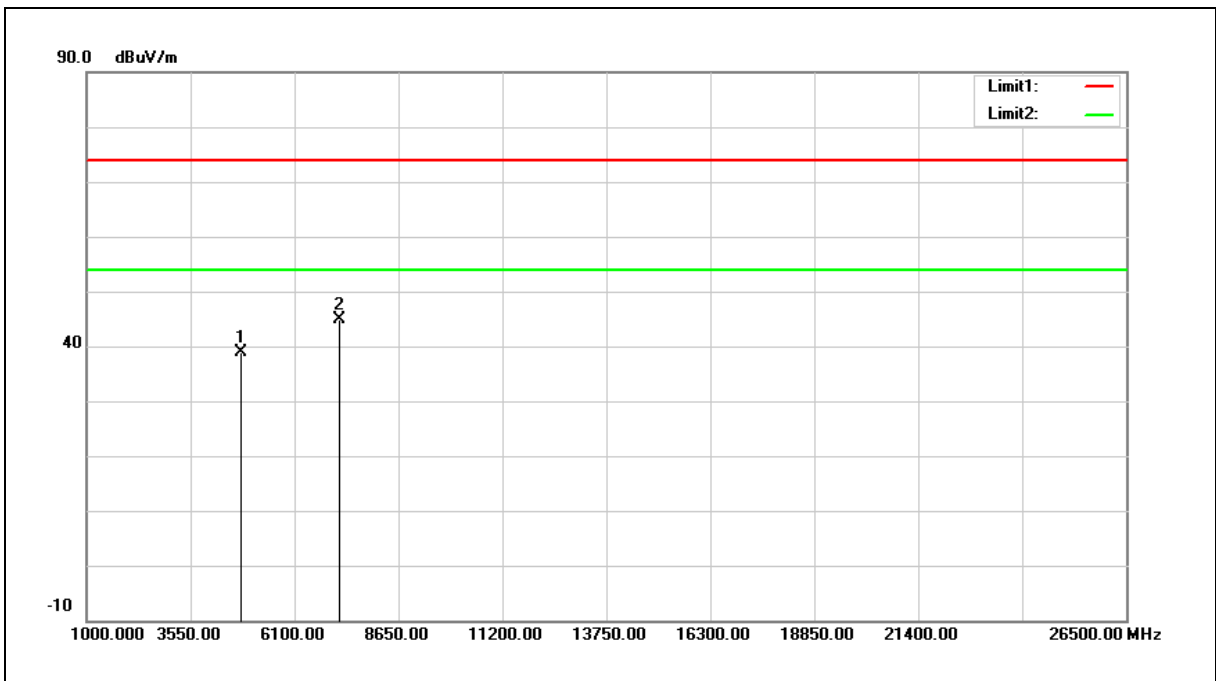

No.	Frequency (MHz)	Reading (dBuV)	Correct Factor (dB/m)	Result (dBuV/m)	Limit (dBuV/m)	Margin (dB)	Remark
1	4804.000	35.02	3.97	38.99	74.00	-35.01	peak
2	7206.000	34.78	10.10	44.88	74.00	-29.12	peak

- Note:1.Result (dBuV/m) = Correct Factor (dB/m) + Reading(dBuV).
 2.Correction factor (dB/m) = Antenna Factor (dB/m) + Cable loss (dB) – Pre-Amplifier gain (dB).
 3.When the peak results are less than average limit, so not need to evaluate the average.

Standard:	FCC Part 15.247	Test Distance:	3 m
Test item:	Harmonic		
Frequency:	2440 MHz		
Mode:	Mode 2		
Ant.Polar.:	Horizontal		

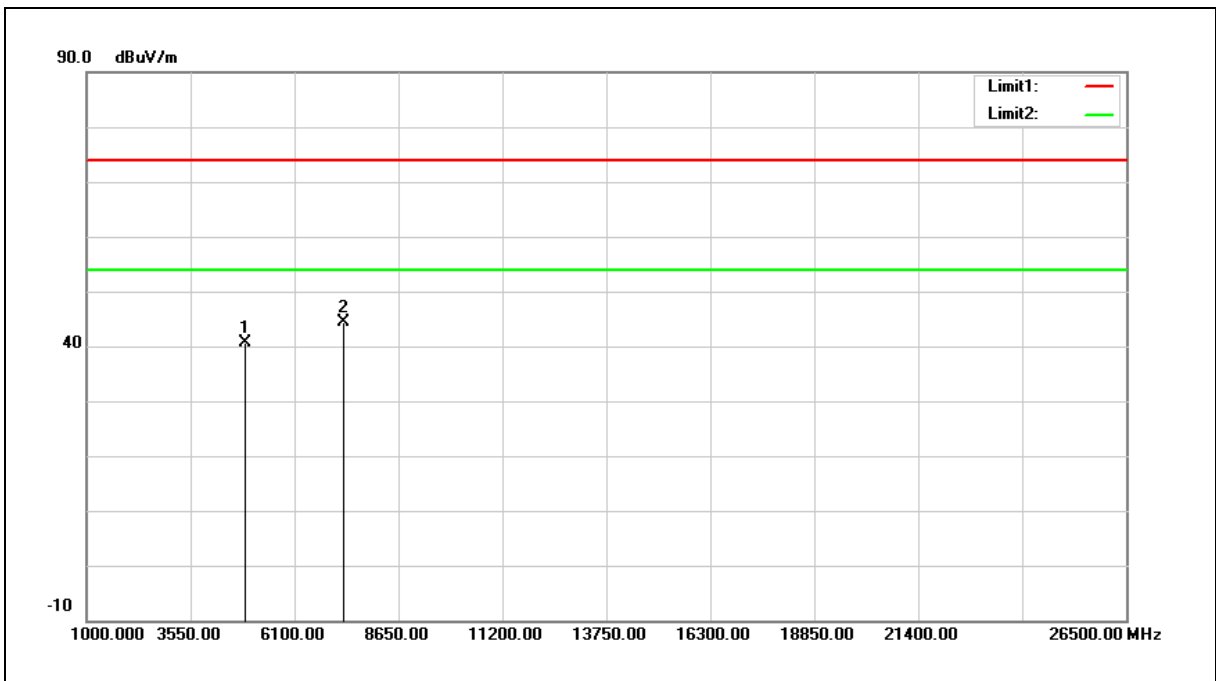

No.	Frequency (MHz)	Reading (dBuV)	Correct Factor (dB/m)	Result (dBuV/m)	Limit (dBuV/m)	Margin (dB)	Remark
1	4880.000	36.45	4.21	40.66	74.00	-33.34	peak
2	7320.000	33.96	10.44	44.40	74.00	-29.60	peak

- Note:1.Result (dBuV/m) = Correct Factor (dB/m) + Reading(dBuV).
 2.Correction factor (dB/m) = Antenna Factor (dB/m) + Cable loss (dB) – Pre-Amplifier gain (dB).
 3.When the peak results are less than average limit, so not need to evaluate the average.

Standard:	FCC Part 15.247	Test Distance:	3 m
Test item:	Harmonic		
Frequency:	2440 MHz		
Mode:	Mode 2		
Ant.Polar.:	Vertical		

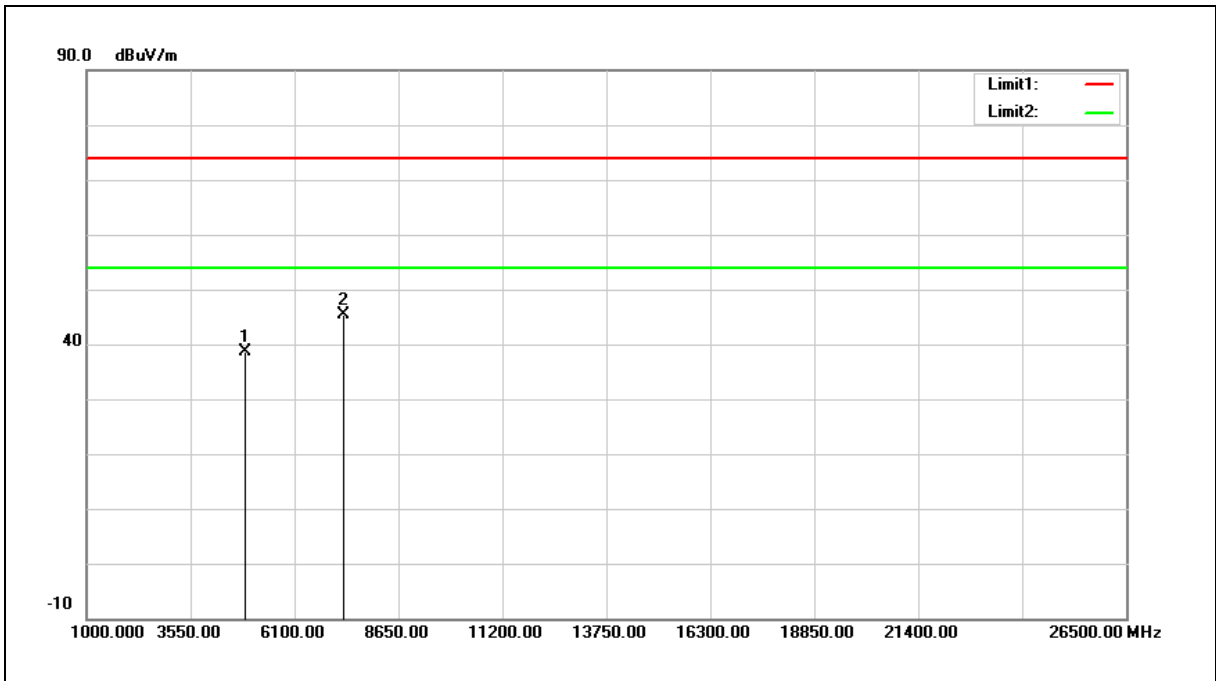

No.	Frequency (MHz)	Reading (dBuV)	Correct Factor (dB/m)	Result (dBuV/m)	Limit (dBuV/m)	Margin (dB)	Remark
1	4880.000	34.49	4.21	38.70	74.00	-35.30	peak
2	7320.000	35.06	10.44	45.50	74.00	-28.50	peak

- Note:1.Result (dBuV/m) = Correct Factor (dB/m) + Reading(dBuV).
 2.Correction factor (dB/m) = Antenna Factor (dB/m) + Cable loss (dB) – Pre-Amplifier gain (dB).
 3.When the peak results are less than average limit, so not need to evaluate the average.

Standard:	FCC Part 15.247	Test Distance:	3 m
Test item:	Harmonic		
Frequency:	2480 MHz		
Mode:	Mode 2		
Ant.Polar.:	Horizontal		

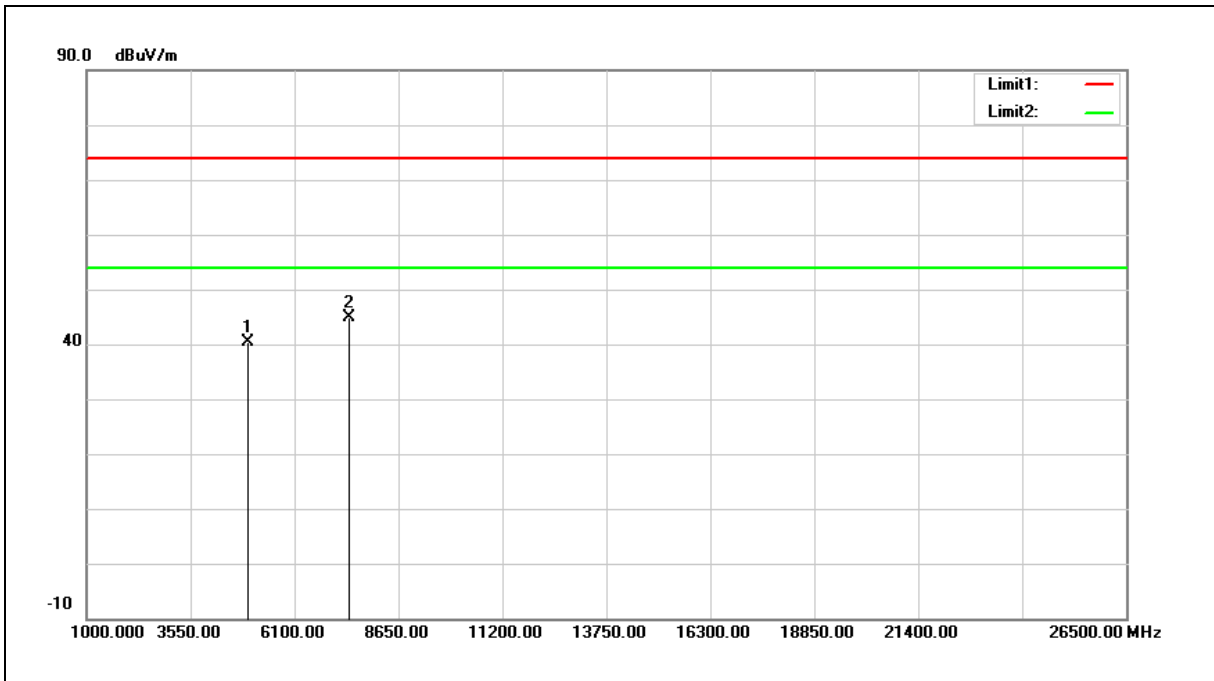

No.	Frequency (MHz)	Reading (dBuV)	Correct Factor (dB/m)	Result (dBuV/m)	Limit (dBuV/m)	Margin (dB)	Remark
1	4960.000	35.89	4.47	40.36	74.00	-33.64	peak
2	7440.000	33.95	10.81	44.76	74.00	-29.24	peak

Note:1.Result (dBuV/m) = Correct Factor (dB/m) + Reading(dBuV).

2.Correction factor (dB/m) = Antenna Factor (dB/m) + Cable loss (dB) – Pre-Amplifier gain (dB).

3.When the peak results are less than average limit, so not need to evaluate the average.

Standard:	FCC Part 15.247	Test Distance:	3 m
Test item:	Harmonic		
Frequency:	2480 MHz		
Mode:	Mode 2		
Ant.Polar.:	Vertical		

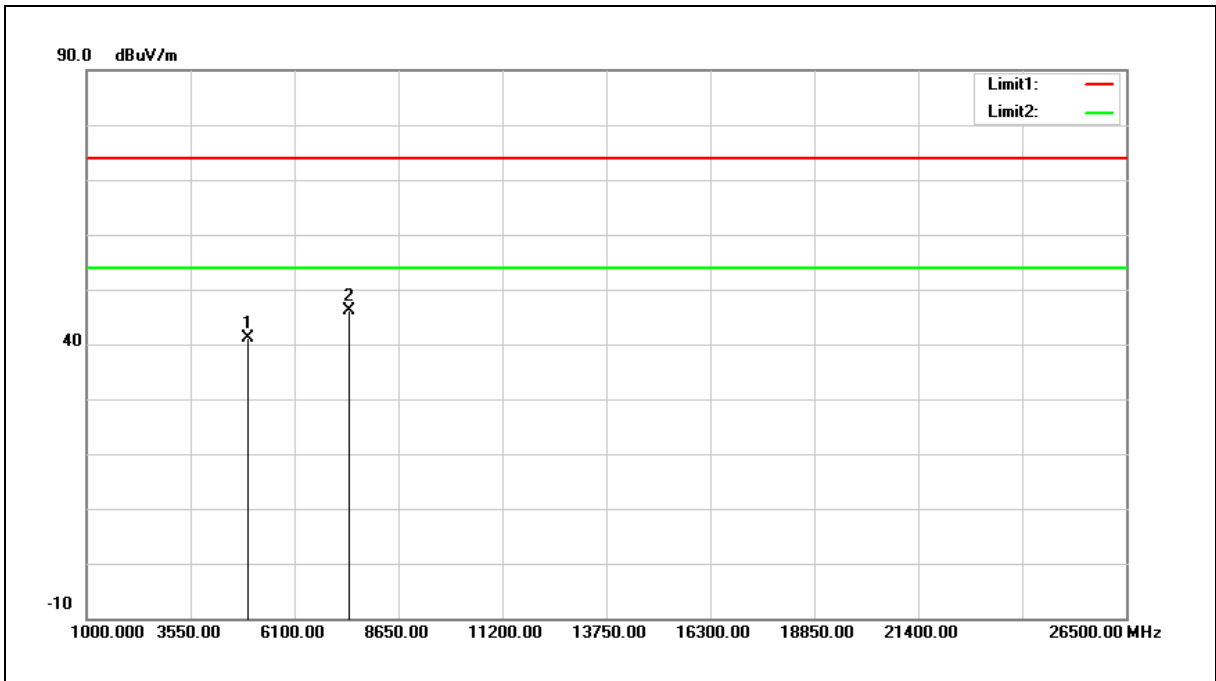

No.	Frequency (MHz)	Reading (dBuV)	Correct Factor (dB/m)	Result (dBuV/m)	Limit (dBuV/m)	Margin (dB)	Remark
1	4960.000	36.59	4.47	41.06	74.00	-32.94	peak
2	7440.000	35.22	10.81	46.03	74.00	-27.97	peak

- Note:1.Result (dBuV/m) = Correct Factor (dB/m) + Reading(dBuV).
 2.Correction factor (dB/m) = Antenna Factor (dB/m) + Cable loss (dB) – Pre-Amplifier gain (dB).
 3.When the peak results are less than average limit, so not need to evaluate the average.

Standard:	FCC Part 15.247	Test Distance:	3 m
Test item:	Harmonic		
Frequency:	2402 MHz		
Mode:	Mode 4		
Ant.Polar.:	Horizontal		

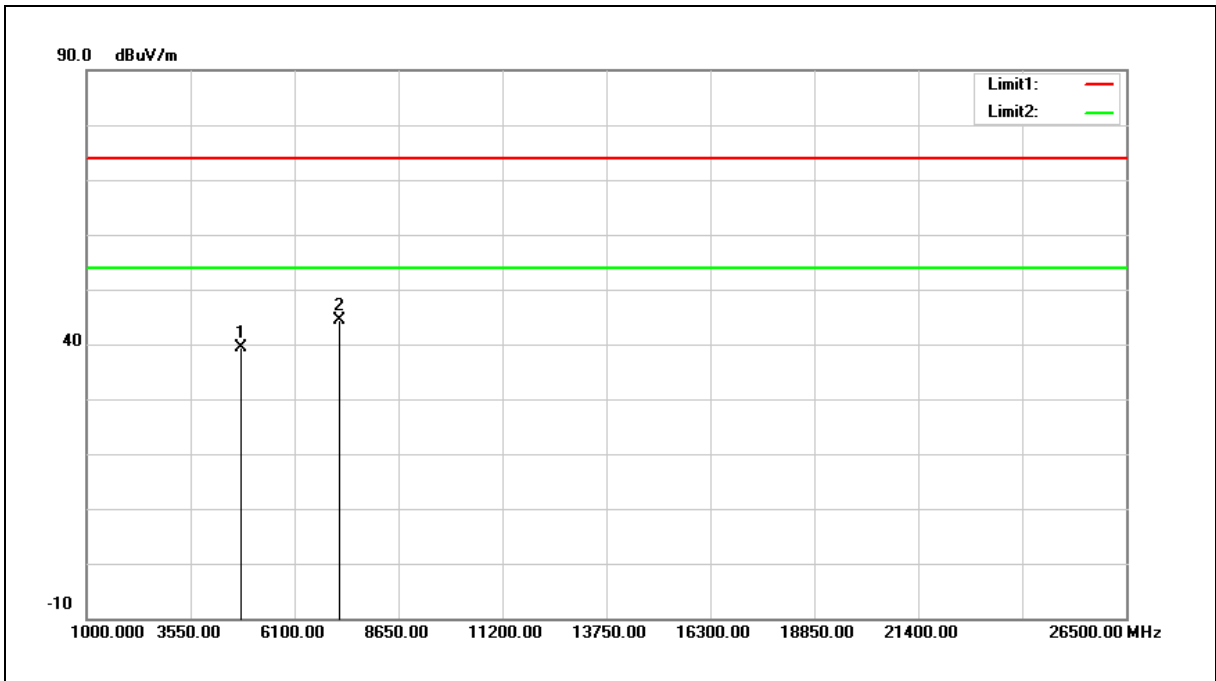

No.	Frequency (MHz)	Reading (dBuV)	Correct Factor (dB/m)	Result (dBuV/m)	Limit (dBuV/m)	Margin (dB)	Remark
1	4804.000	35.46	3.97	39.43	74.00	-34.57	peak
2	7206.000	34.37	10.10	44.47	74.00	-29.53	peak

Note:1.Result (dBuV/m) = Correct Factor (dB/m) + Reading(dBuV).

2.Correction factor (dB/m) = Antenna Factor (dB/m) + Cable loss (dB) – Pre-Amplifier gain (dB).

3.When the peak results are less than average limit, so not need to evaluate the average.

Standard:	FCC Part 15.247	Test Distance:	3 m
Test item:	Harmonic		
Frequency:	2402 MHz		
Mode:	Mode 4		
Ant.Polar.:	Vertical		

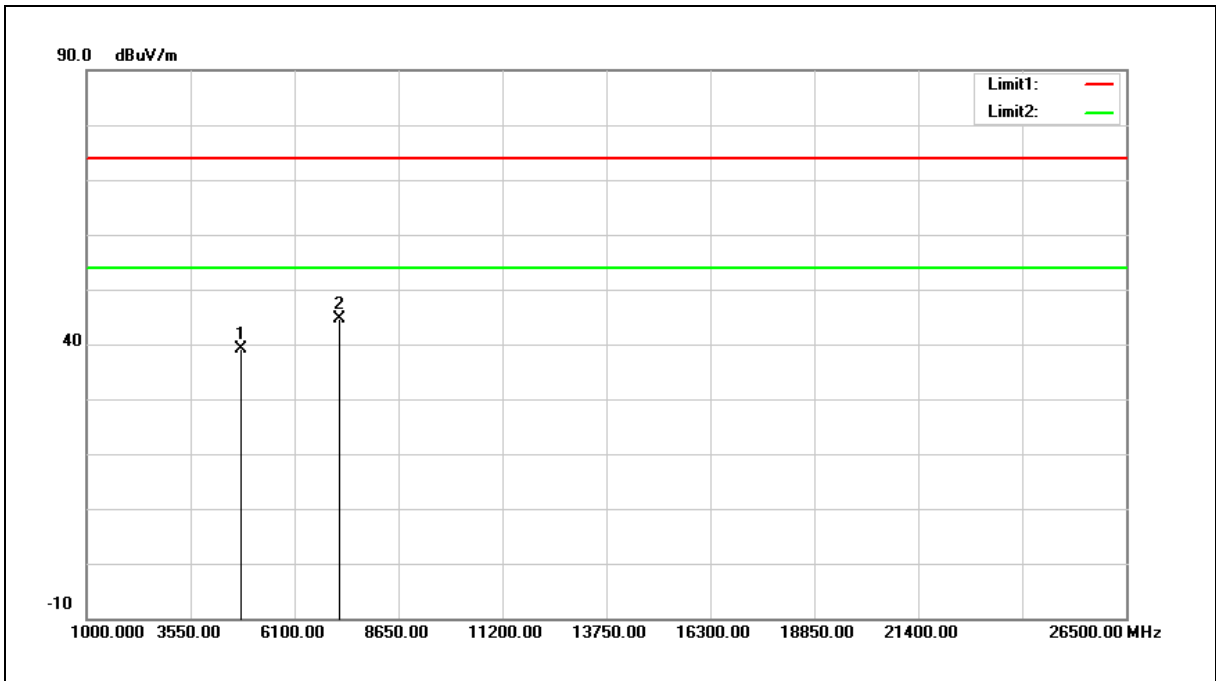

No.	Frequency (MHz)	Reading (dBuV)	Correct Factor (dB/m)	Result (dBuV/m)	Limit (dBuV/m)	Margin (dB)	Remark
1	4804.000	35.27	3.97	39.24	74.00	-34.76	peak
2	7206.000	34.60	10.10	44.70	74.00	-29.30	peak

Note:1.Result (dBuV/m) = Correct Factor (dB/m) + Reading(dBuV).

2.Correction factor (dB/m) = Antenna Factor (dB/m) + Cable loss (dB) – Pre-Amplifier gain (dB).

3.When the peak results are less than average limit, so not need to evaluate the average.

Standard:	FCC Part 15.247	Test Distance:	3 m
Test item:	Harmonic		
Frequency:	2440 MHz		
Mode:	Mode 4		
Ant.Polar.:	Horizontal		

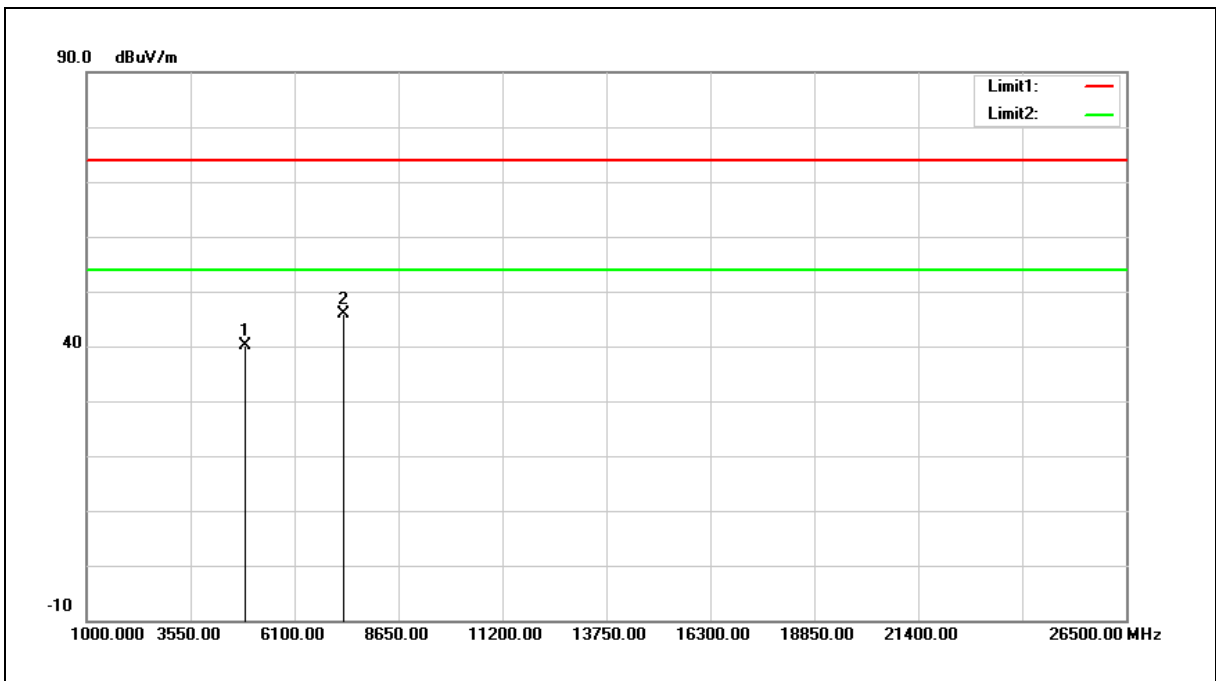

No.	Frequency (MHz)	Reading (dBuV)	Correct Factor (dB/m)	Result (dBuV/m)	Limit (dBuV/m)	Margin (dB)	Remark
1	4880.000	35.88	4.21	40.09	74.00	-33.91	peak
2	7320.000	35.51	10.44	45.95	74.00	-28.05	peak

- Note:1.Result (dBuV/m) = Correct Factor (dB/m) + Reading(dBuV).
 2.Correction factor (dB/m) = Antenna Factor (dB/m) + Cable loss (dB) – Pre-Amplifier gain (dB).
 3.When the peak results are less than average limit, so not need to evaluate the average.

Standard:	FCC Part 15.247	Test Distance:	3 m
Test item:	Harmonic		
Frequency:	2440 MHz		
Mode:	Mode 4		
Ant.Polar.:	Vertical		

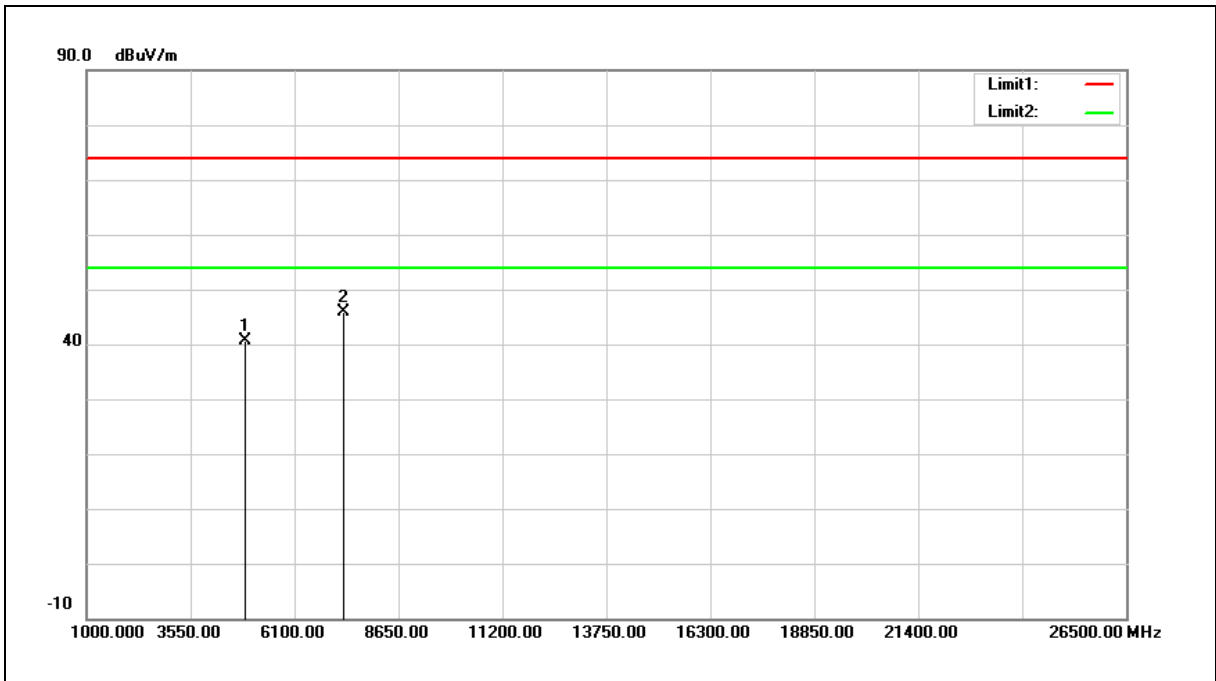

No.	Frequency (MHz)	Reading (dBuV)	Correct Factor (dB/m)	Result (dBuV/m)	Limit (dBuV/m)	Margin (dB)	Remark
1	4880.000	36.31	4.21	40.52	74.00	-33.48	peak
2	7320.000	35.51	10.44	45.95	74.00	-28.05	peak

Note:1.Result (dBuV/m) = Correct Factor (dB/m) + Reading(dBuV).

2.Correction factor (dB/m) = Antenna Factor (dB/m) + Cable loss (dB) – Pre-Amplifier gain (dB).

3.When the peak results are less than average limit, so not need to evaluate the average.

Standard:	FCC Part 15.247	Test Distance:	3 m
Test item:	Harmonic		
Frequency:	2480 MHz		
Mode:	Mode 4		
Ant.Polar.:	Horizontal		

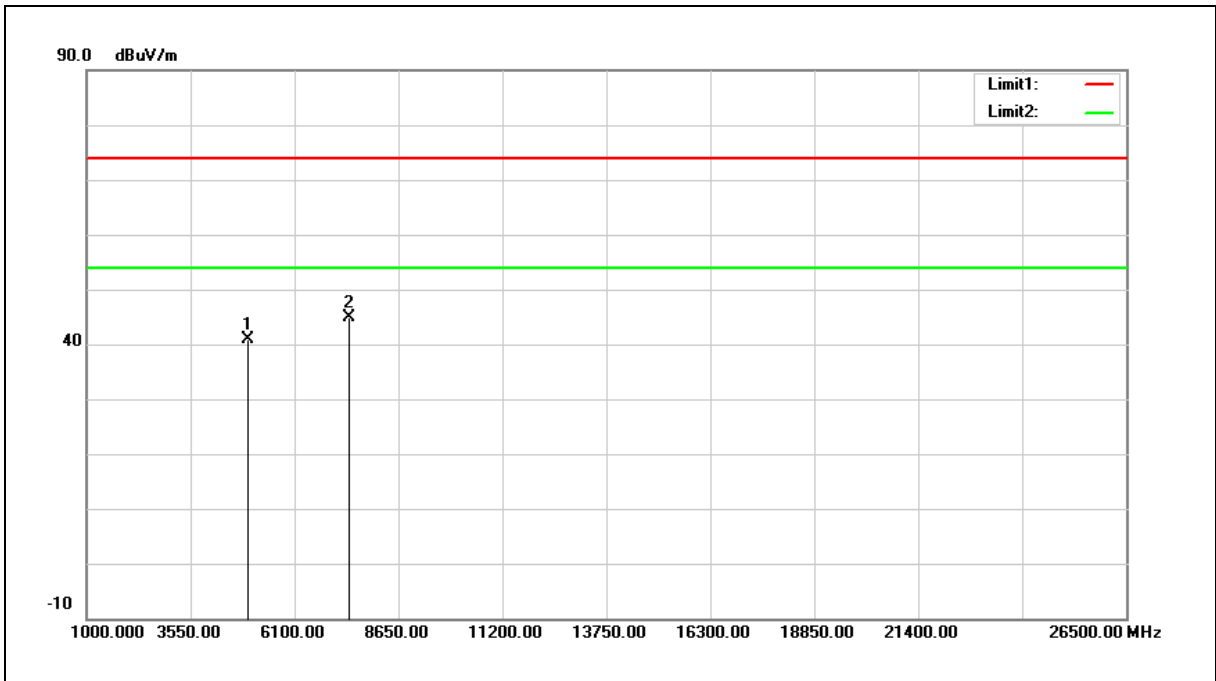

No.	Frequency (MHz)	Reading (dBuV)	Correct Factor (dB/m)	Result (dBuV/m)	Limit (dBuV/m)	Margin (dB)	Remark
1	4960.000	36.30	4.47	40.77	74.00	-33.23	peak
2	7440.000	34.09	10.81	44.90	74.00	-29.10	peak

Note:1.Result (dBuV/m) = Correct Factor (dB/m) + Reading(dBuV).

2.Correction factor (dB/m) = Antenna Factor (dB/m) + Cable loss (dB) – Pre-Amplifier gain (dB).

3.When the peak results are less than average limit, so not need to evaluate the average.

Standard:	FCC Part 15.247	Test Distance:	3 m
Test item:	Harmonic		
Frequency:	2480 MHz		
Mode:	Mode 4		
Ant.Polar.:	Vertical		

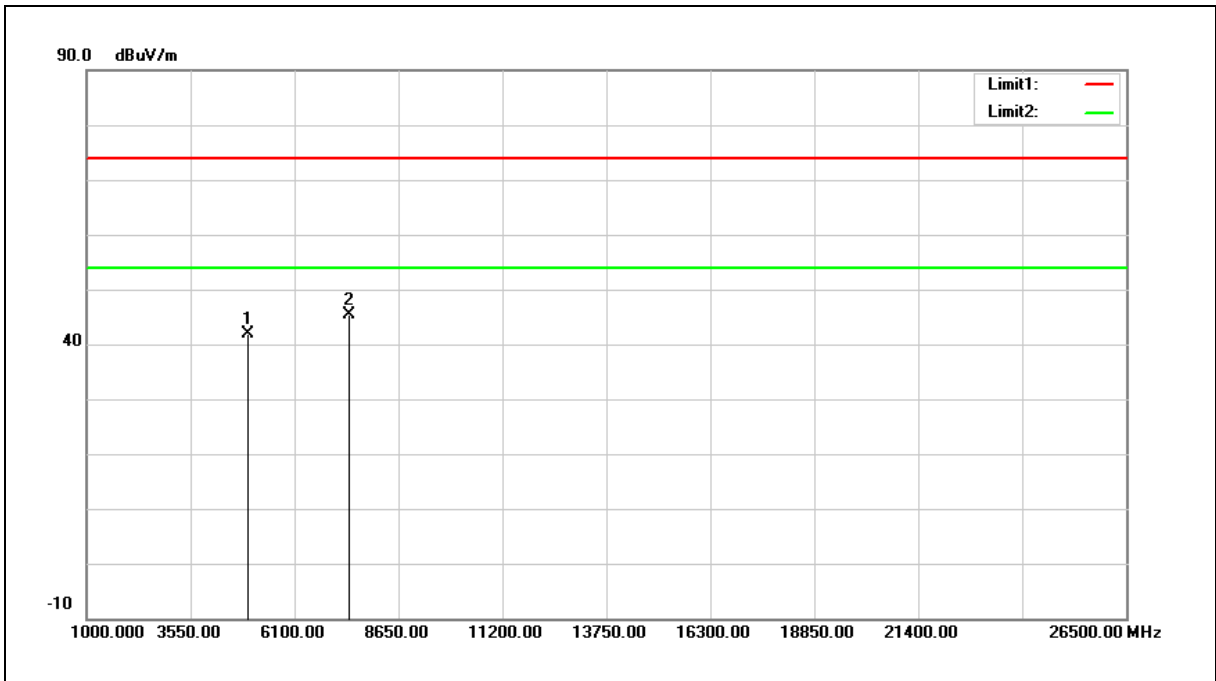

No.	Frequency (MHz)	Reading (dBuV)	Correct Factor (dB/m)	Result (dBuV/m)	Limit (dBuV/m)	Margin (dB)	Remark
1	4960.000	37.43	4.47	41.90	74.00	-32.10	peak
2	7440.000	34.64	10.81	45.45	74.00	-28.55	peak

Note:1.Result (dBuV/m) = Correct Factor (dB/m) + Reading(dBuV).

2.Correction factor (dB/m) = Antenna Factor (dB/m) + Cable loss (dB) – Pre-Amplifier gain (dB).

3.When the peak results are less than average limit, so not need to evaluate the average.

Band Edge

Peak

Standard:	FCC Part 15.247	Test Distance:	3 m
Test item:	Band edge		
Frequency:	2402 MHz		
Mode:	Mode 2		
Ant.Polar.:	Horizontal		

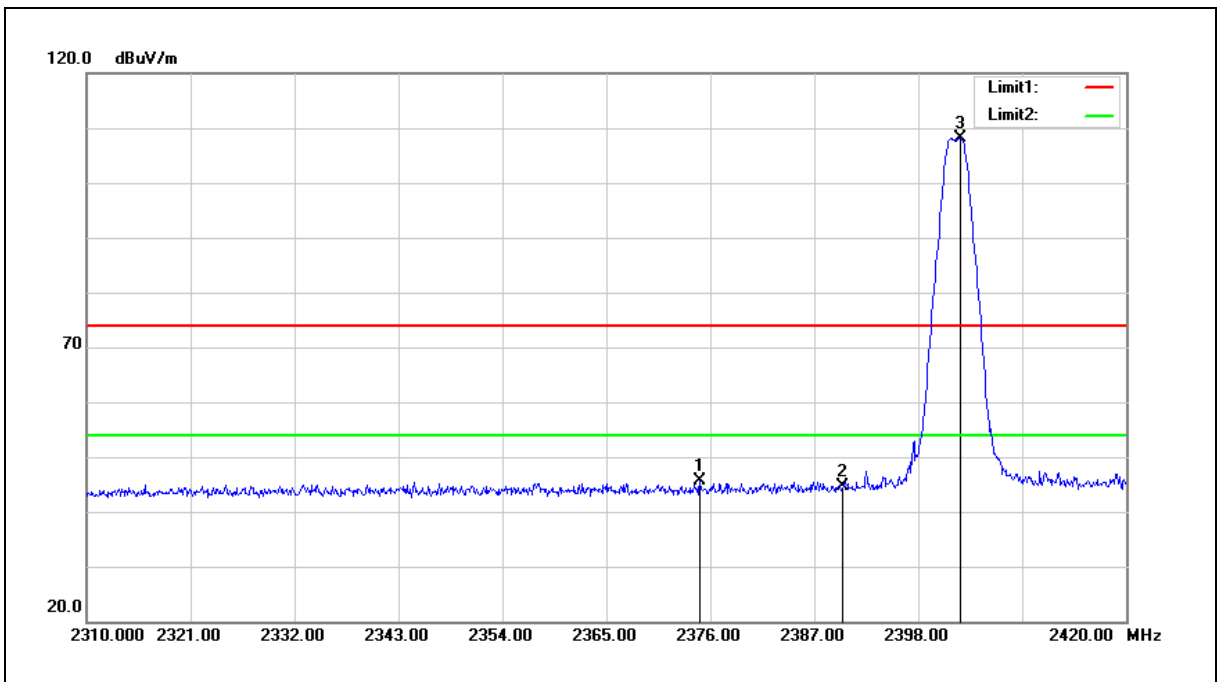

No.	Frequency (MHz)	Reading (dBuV)	Correct Factor (dB/m)	Result (dBuV/m)	Limit (dBuV/m)	Margin (dB)	Remark
1	2374.900	47.91	-2.27	45.64	74.00	-28.36	peak
2	2390.000	46.74	-2.21	44.53	74.00	-29.47	peak
3	2402.510	110.38	-2.16	108.22	74.00	34.22	peak

Note:1.Result (dBuV/m) = Correct Factor (dB/m) + Reading(dBuV).

2.Correction factor (dB/m) = Antenna Factor (dB/m) + Cable loss (dB) – Pre-Amplifier gain (dB).

3.When the peak results are less than average limit, so not need to evaluate the average.

Standard:	FCC Part 15.247	Test Distance:	3 m
Test item:	Band edge		
Frequency:	2402 MHz		
Mode:	Mode 2		
Ant.Polar.:	Vertical		

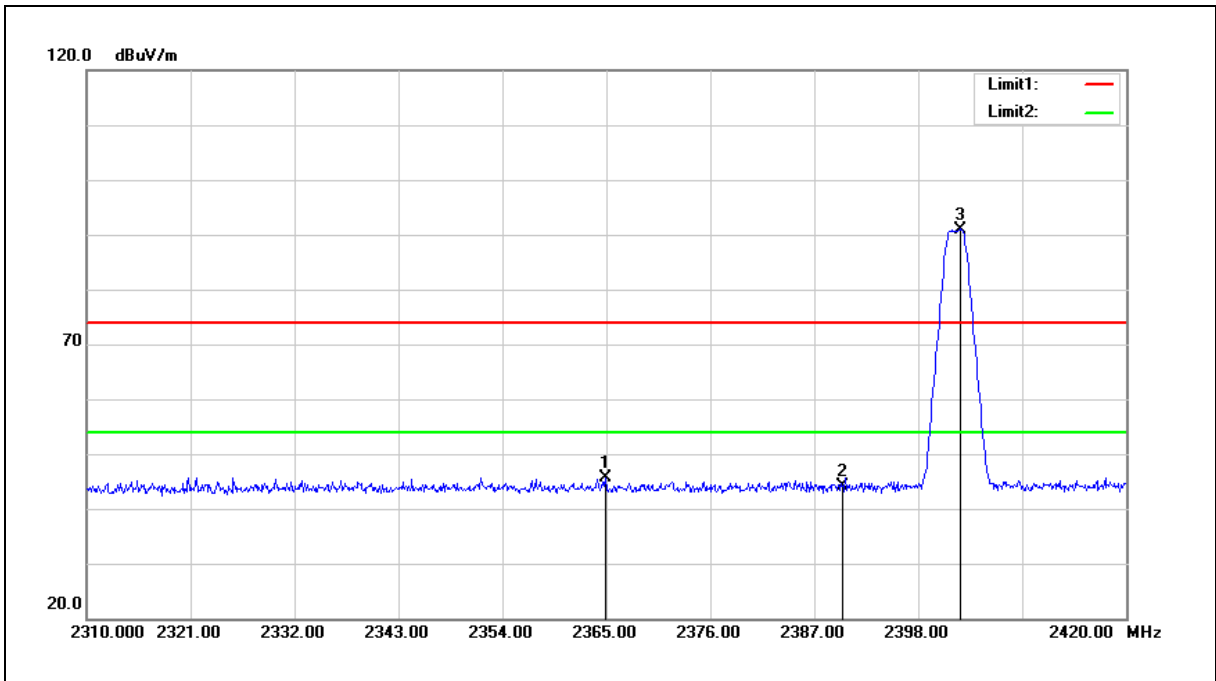

No.	Frequency (MHz)	Reading (dBuV)	Correct Factor (dB/m)	Result (dBuV/m)	Limit (dBuV/m)	Margin (dB)	Remark
1	2364.890	48.00	-2.31	45.69	74.00	-28.31	peak
2	2390.000	46.27	-2.21	44.06	74.00	-29.94	peak
3	2402.400	93.16	-2.16	91.00	74.00	17.00	peak

Note:1.Result (dBuV/m) = Correct Factor (dB/m) + Reading(dBuV).

2.Correction factor (dB/m) = Antenna Factor (dB/m) + Cable loss (dB) – Pre-Amplifier gain (dB).

3.When the peak results are less than average limit, so not need to evaluate the average.

Standard:	FCC Part 15.247	Test Distance:	3 m
Test item:	Band edge		
Mode:	Mode 2		
Ant.Polar.:	Horizontal		
Description:			

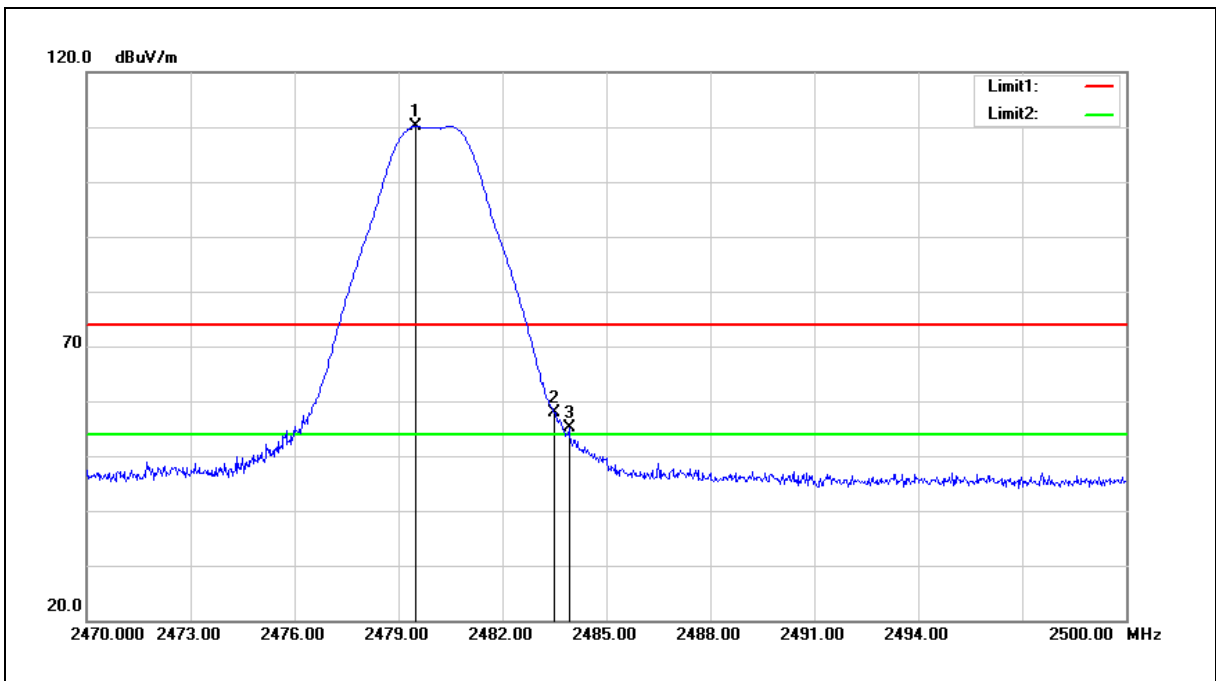

No.	Frequency (MHz)	Reading (dBuV)	Correct Factor (dB/m)	Result (dBuV/m)	Limit (dBuV/m)	Margin (dB)	Remark
1	2479.480	112.05	-1.88	110.17	74.00	36.17	peak
2	2483.500	59.65	-1.87	57.78	74.00	-16.22	peak
3	2483.920	56.88	-1.87	55.01	74.00	-18.99	peak

Note:1.Result (dBuV/m) = Correct Factor (dB/m) + Reading(dBuV).

2.Correction factor (dB/m) = Antenna Factor (dB/m) + Cable loss (dB) – Pre-Amplifier gain (dB).

3.When the peak results are less than average limit, so not need to evaluate the average.

Standard:	FCC Part 15.247	Test Distance:	3 m
Test item:	Band edge		
Frequency:	2480 MHz		
Mode:	Mode 2		
Ant.Polar.:	Vertical		

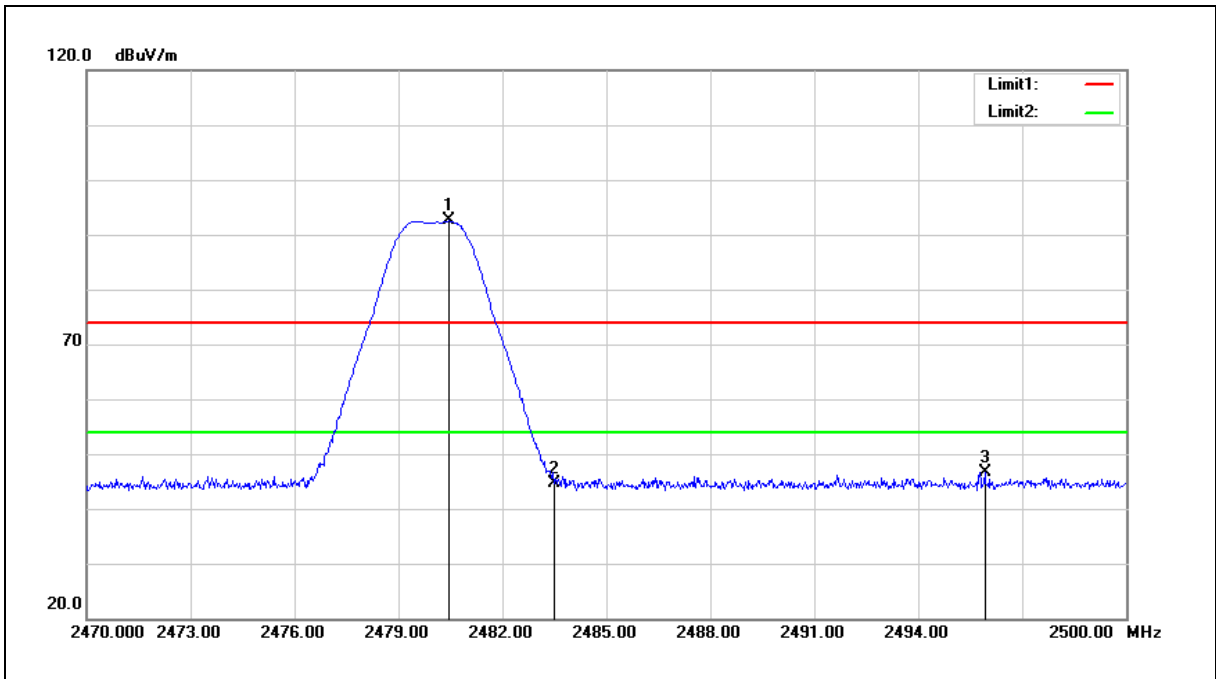

No.	Frequency (MHz)	Reading (dBuV)	Correct Factor (dB/m)	Result (dBuV/m)	Limit (dBuV/m)	Margin (dB)	Remark
1	2480.470	94.39	-1.87	92.52	74.00	18.52	peak
2	2483.500	46.62	-1.87	44.75	74.00	-29.25	peak
3	2495.920	48.44	-1.81	46.63	74.00	-27.37	peak

Note:1.Result (dBuV/m) = Correct Factor (dB/m) + Reading(dBuV).

2.Correction factor (dB/m) = Antenna Factor (dB/m) + Cable loss (dB) – Pre-Amplifier gain (dB).

3.When the peak results are less than average limit, so not need to evaluate the average.

Standard:	FCC Part 15.247	Test Distance:	3 m
Test item:	Band edge		
Frequency:	2402 MHz		
Mode:	Mode 4		
Ant.Polar.:	Horizontal		

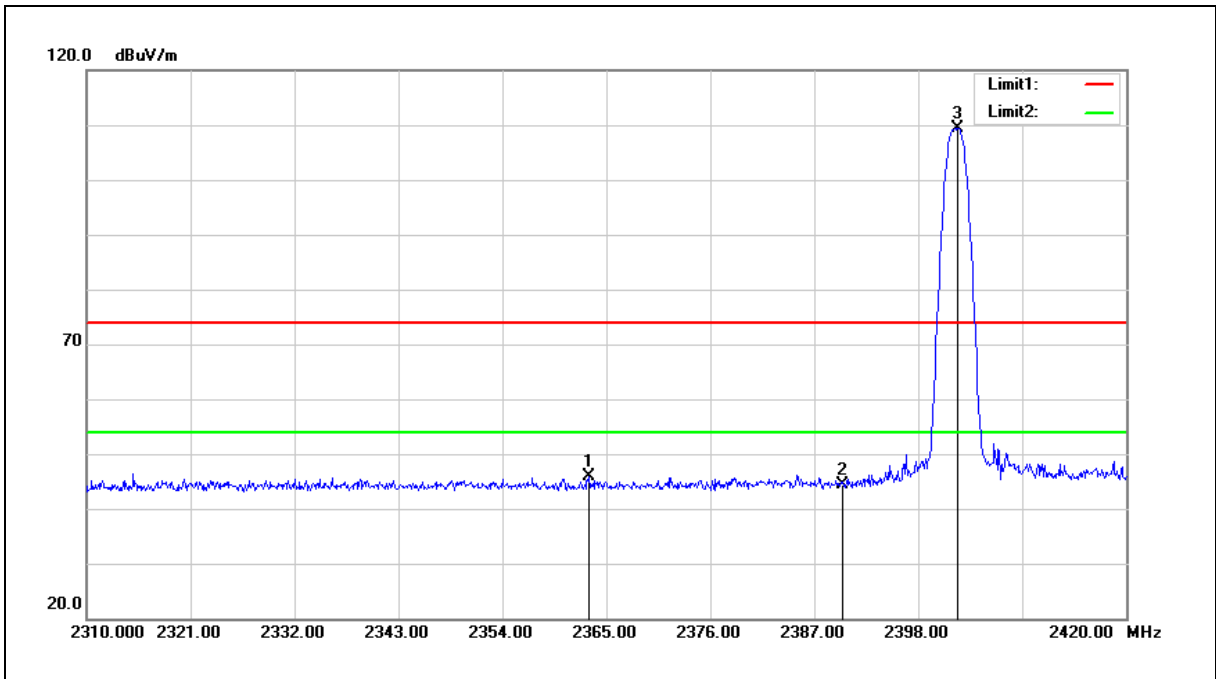

No.	Frequency (MHz)	Reading (dBuV)	Correct Factor (dB/m)	Result (dBuV/m)	Limit (dBuV/m)	Margin (dB)	Remark
1	2363.130	48.15	-2.31	45.84	74.00	-28.16	peak
2	2390.000	46.62	-2.21	44.41	74.00	-29.59	peak
3	2402.180	111.56	-2.16	109.40	74.00	35.40	peak

Note:1.Result (dBuV/m) = Correct Factor (dB/m) + Reading(dBuV).

2.Correction factor (dB/m) = Antenna Factor (dB/m) + Cable loss (dB) – Pre-Amplifier gain (dB).

3.When the peak results are less than average limit, so not need to evaluate the average.

Standard:	FCC Part 15.247	Test Distance:	3 m
Test item:	Band edge		
Frequency:	2402 MHz		
Mode:	Mode 4		
Ant.Polar.:	Vertical		

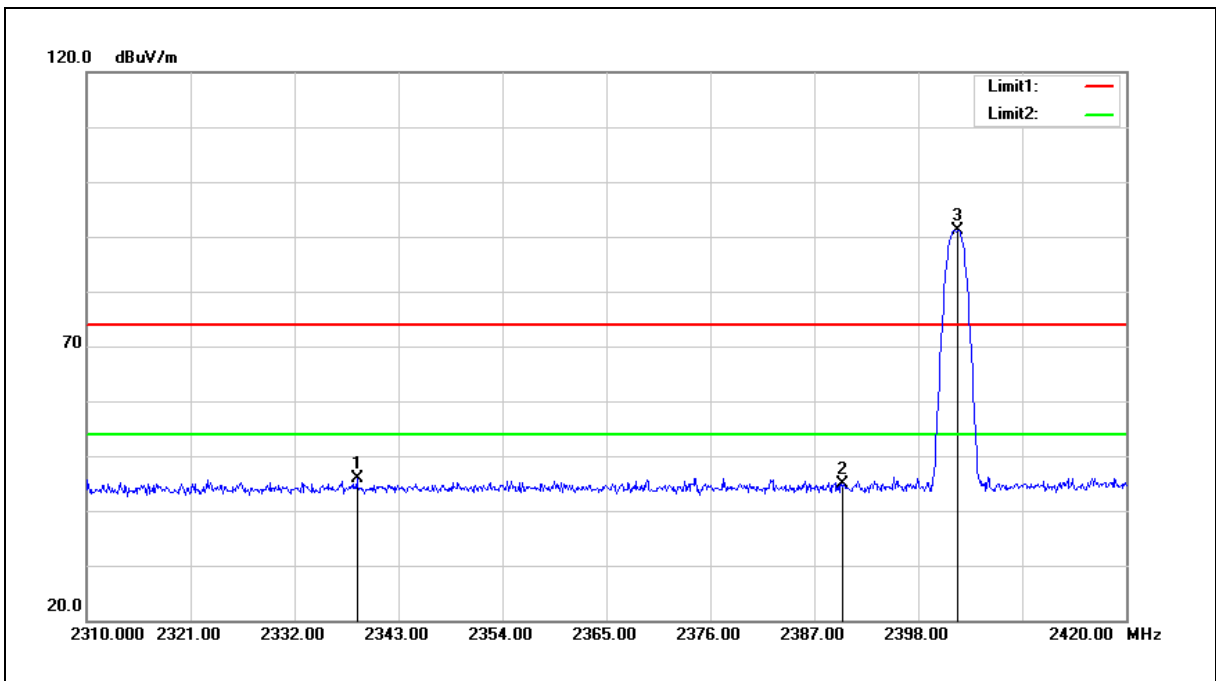

No.	Frequency (MHz)	Reading (dBuV)	Correct Factor (dB/m)	Result (dBuV/m)	Limit (dBuV/m)	Margin (dB)	Remark
1	2338.600	48.37	-2.39	45.98	74.00	-28.02	peak
2	2390.000	46.98	-2.21	44.77	74.00	-29.23	peak
3	2402.180	93.25	-2.16	91.09	74.00	17.09	peak

Note:1.Result (dBuV/m) = Correct Factor (dB/m) + Reading(dBuV).

2.Correction factor (dB/m) = Antenna Factor (dB/m) + Cable loss (dB) – Pre-Amplifier gain (dB).

3.When the peak results are less than average limit, so not need to evaluate the average.

Standard:	FCC Part 15.247	Test Distance:	3 m
Test item:	Band edge		
Frequency:	2480 MHz		
Mode:	Mode 4		
Ant.Polar.:	Horizontal		

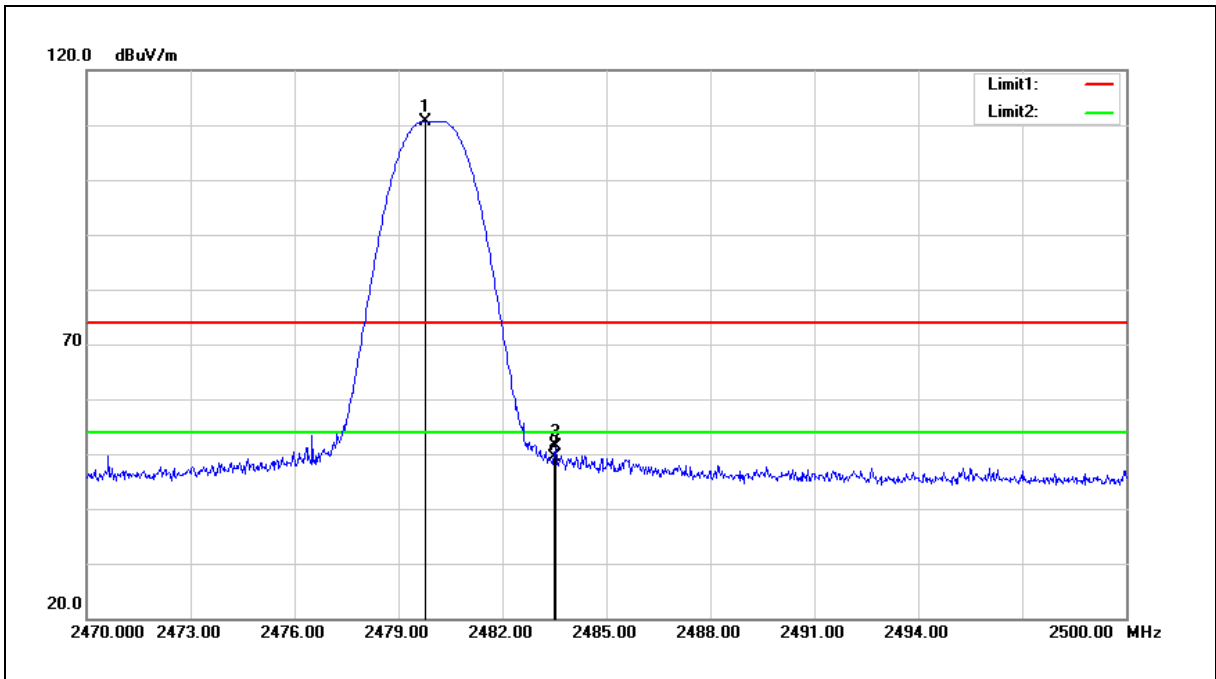

No.	Frequency (MHz)	Reading (dBuV)	Correct Factor (dB/m)	Result (dBuV/m)	Limit (dBuV/m)	Margin (dB)	Remark
1	2479.780	112.61	-1.88	110.73	74.00	36.73	peak
2	2483.500	51.20	-1.87	49.33	74.00	-24.67	peak
3	2483.530	53.16	-1.87	51.29	74.00	-22.71	peak

Note:1.Result (dBuV/m) = Correct Factor (dB/m) + Reading(dBuV).

2.Correction factor (dB/m) = Antenna Factor (dB/m) + Cable loss (dB) – Pre-Amplifier gain (dB).

3.When the peak results are less than average limit, so not need to evaluate the average.

Standard:	FCC Part 15.247	Test Distance:	3 m
Test item:	Band edge		
Frequency:	2480 MHz		
Mode:	Mode 4		
Ant.Polar.:	Vertical		

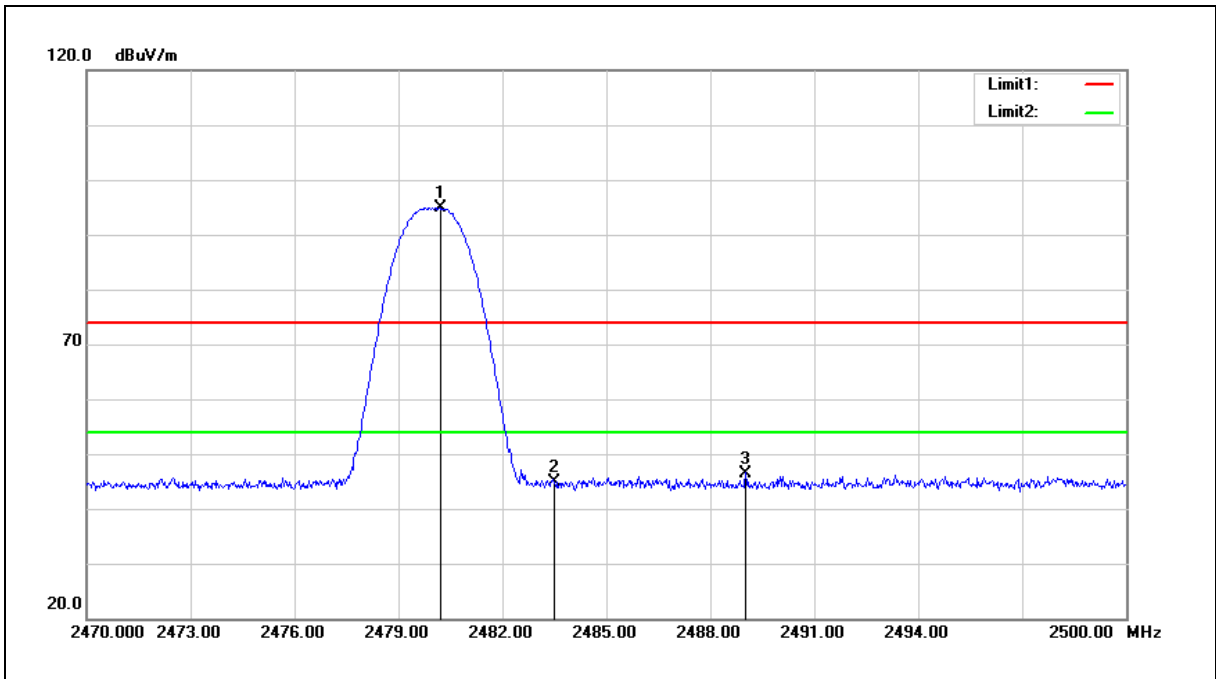

No.	Frequency (MHz)	Reading (dBuV)	Correct Factor (dB/m)	Result (dBuV/m)	Limit (dBuV/m)	Margin (dB)	Remark
1	2480.200	96.79	-1.88	94.91	74.00	20.91	peak
2	2483.500	46.68	-1.87	44.81	74.00	-29.19	peak
3	2489.020	48.34	-1.84	46.50	74.00	-27.50	peak

Note:1.Result (dBuV/m) = Correct Factor (dB/m) + Reading(dBuV).

2.Correction factor (dB/m) = Antenna Factor (dB/m) + Cable loss (dB) – Pre-Amplifier gain (dB).

3.When the peak results are less than average limit, so not need to evaluate the average.

Average

Standard:	FCC Part 15.247	Test Distance:	3 m
Test item:	Band edge		
Frequency:	2480 MHz		
Mode:	Mode 2		
Ant.Polar.:	Horizontal		

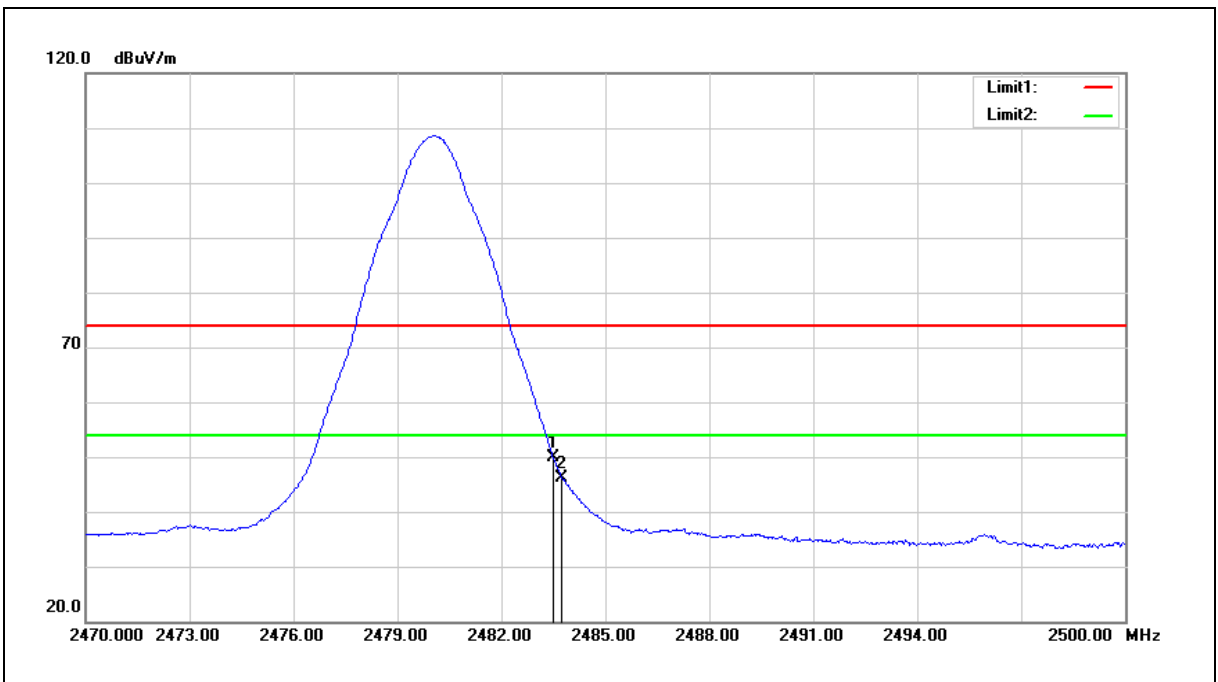

No.	Frequency (MHz)	Reading (dBuV)	Correct Factor (dB/m)	Result (dBuV/m)	Limit (dBuV/m)	Margin (dB)	Remark
1	2483.500	51.72	-1.87	49.85	54.00	-4.15	AVG
2	2483.740	48.00	-1.87	46.13	54.00	-7.87	AVG

Note:1.Result (dBuV/m) = Correct Factor (dB/m) + Reading(dBuV).

2.Correction factor (dB/m) = Antenna Factor (dB/m) + Cable loss (dB) – Pre-Amplifier gain (dB).

3.When the peak results are less than average limit, so not need to evaluate the average.

Standard:	FCC Part 15.247	Test Distance:	3 m
Test item:	Band edge		
Frequency:	2480 MHz		
Mode:	Mode 2		
Ant.Polar.:	Vertical		

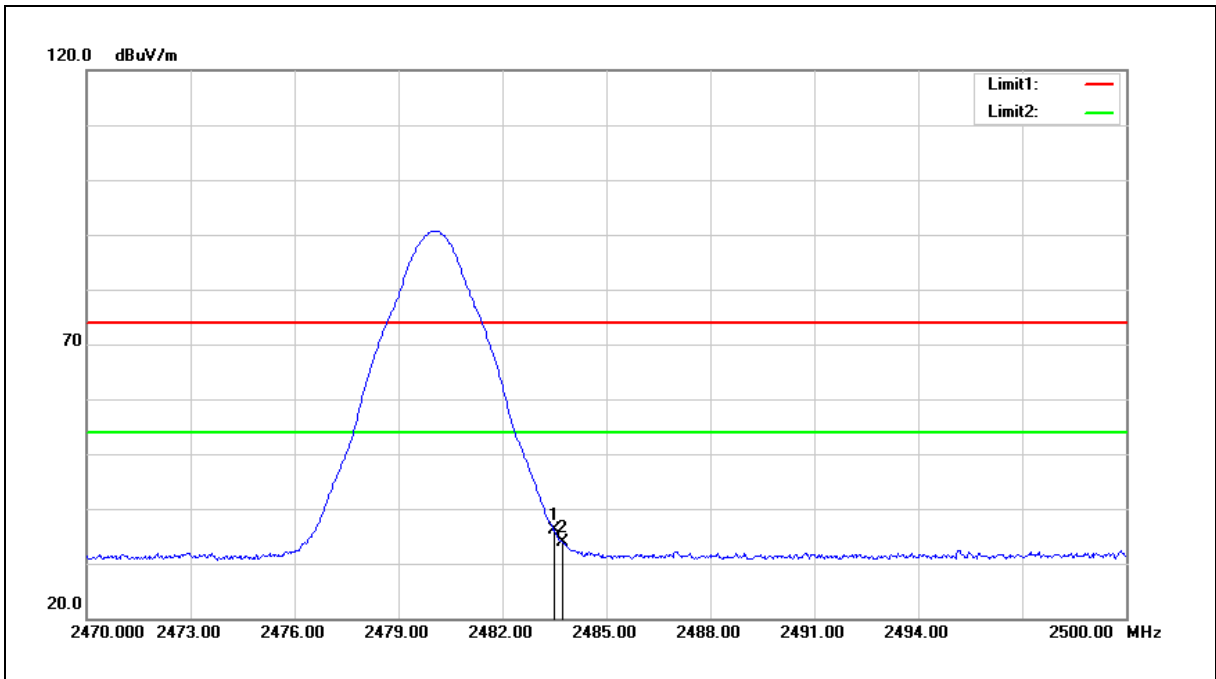

No.	Frequency (MHz)	Reading (dBuV)	Correct Factor (dB/m)	Result (dBuV/m)	Limit (dBuV/m)	Margin (dB)	Remark
1	2483.500	37.89	-1.87	36.02	54.00	-17.98	AVG
2	2483.740	35.78	-1.87	33.91	54.00	-20.09	AVG

- Note:1.Result (dBuV/m) = Correct Factor (dB/m) + Reading(dBuV).
 2.Correction factor (dB/m) = Antenna Factor (dB/m) + Cable loss (dB) – Pre-Amplifier gain (dB).
 3.When the peak results are less than average limit, so not need to evaluate the average.

---END---