

## Variant FCC Test Report

**Report No.:** RF170818C25B

**FCC ID:** 2ADWC-AI7697HD

**Test Model:** AI7697HD

**Received Date:** Aug. 30, 2018

**Test Date:** Sep. 07, 2018 ~ Sep. 18, 2018

**Issued Date:** Sep. 21, 2018

**Applicant:** AcSiP Technology Corporation

**Address:** 3F.-1, No.207, Fusing Rd., Taoyuan Dist., Taoyuan County 330, Taiwan  
(R.O.C.)

**Issued By:** Bureau Veritas Consumer Products Services (H.K.) Ltd., Taoyuan Branch

**Lab Address:** No. 47-2, 14th Ling, Chia Pau Vil., Lin Kou Dist., New Taipei City, Taiwan  
( R.O.C )

**Test Location:** No.19, Hwa Ya 2nd Rd., Wen Hwa Vil., Kwei Shan Dist., Taoyuan City  
33383, Taiwan, R.O.C.

**FCC Registration /  
Designation Number:** 788550 / TW0003



This report is for your exclusive use. Any copying or replication of this report to or for any other person or entity, or use of our name or trademark, is permitted only with our prior written permission. This report sets forth our findings solely with respect to the test samples identified herein. The results set forth in this report are not indicative or representative of the quality or characteristics of the lot from which a test sample was taken or any similar or identical product unless specifically and expressly noted. Our report includes all of the tests requested by you and the results thereof based upon the information that you provided to us. You have 60 days from date of issuance of this report to notify us of any material error or omission caused by our negligence, provided, however, that such notice shall be in writing and shall specifically address the issue you wish to raise. A failure to raise such issue within the prescribed time shall constitute your unqualified acceptance of the completeness of this report, the tests conducted and the correctness of the report contents. Unless specific mention, the uncertainty of measurement has been explicitly taken into account to declare the compliance or non-compliance to the specification. The report must not be used by the client to claim product certification, approval, or endorsement by TAF or any government agencies.

## Table of Contents

<b>Release Control Record .....</b>	<b>3</b>
<b>1 Certificate of Conformity .....</b>	<b>4</b>
<b>2 Summary of Test Results.....</b>	<b>5</b>
2.1 Measurement Uncertainty.....	5
2.2 Modification Record .....	5
<b>3 General Information .....</b>	<b>6</b>
3.1 General Description of EUT .....	6
3.2 Description of Test Modes.....	7
3.2.1 Test Mode Applicability and Tested Channel Detail.....	8
3.3 Description of Support Units .....	9
3.3.1 Configuration of System under Test .....	9
3.4 General Description of Applied Standards.....	9
<b>4 Test Types and Results .....</b>	<b>10</b>
4.1 Radiated Emission and Bandedge Measurement .....	10
4.1.1 Limits of Radiated Emission and Bandedge Measurement .....	10
4.1.2 Test Instruments .....	11
4.1.3 Test Procedures.....	12
4.1.4 Deviation from Test Standard .....	12
4.1.5 Test Set Up .....	13
4.1.6 EUT Operating Conditions.....	14
4.1.7 Test Results .....	15
4.2 Conducted Emission Measurement.....	23
4.2.1 Limits of Conducted Emission Measurement .....	23
4.2.2 Test Instruments .....	23
4.2.3 Test Procedures.....	23
4.2.4 Deviation from Test Standard .....	24
4.2.5 Test Setup.....	24
4.2.6 EUT Operating Conditions.....	24
4.2.7 Test Results .....	25
<b>5 Pictures of Test Arrangements.....</b>	<b>29</b>
<b>Appendix – Information on the Testing Laboratories .....</b>	<b>30</b>

### Release Control Record

Issue No.	Description	Date Issued
RF170818C25B	Original Release	Sep. 21, 2018

## 1 Certificate of Conformity

**Product:** 802.11 IoT Module

**Brand:** AcSiP

**Test Model:** AI7697HD

**Sample Status:** Production Unit

**Applicant:** AcSiP Technology Corporation

**Test Date:** Sep. 07, 2018 ~ Sep. 18, 2018

**Standards:** 47 CFR FCC Part 15, Subpart C (Section 15.247)  
ANSI C63.10:2013

This report is issued as a supplementary report to BV CPS report no.: RF170818C25. This report shall be used by combining with its original report.

**Prepared by :** Gina Liu, **Date:** Sep. 21, 2018  
Gina Liu / Specialist

**Approved by :** Dylan Chiou, **Date:** Sep. 21, 2018  
Dylan Chiou / Project Engineer

## 2 Summary of Test Results

47 CFR FCC Part 15, Subpart C (Section 15.247)			
FCC Clause	Test Item	Result	Remarks
15.207	AC Power Conducted Emission	Pass	Meet the requirement of limit. Minimum passing margin is -19.69 dB at 0.15782 MHz.
15.205 & 209	Radiated Emissions	Pass	Meet the requirement of limit. Minimum passing margin is -2.94 dB at 746.83 MHz.
15.247(d)	Band Edge Measurement	N/A	Refer to Note
15.247(d)	Antenna Port Emission	N/A	Refer to Note
15.247(a)(2)	6 dB Bandwidth	N/A	Refer to Note
---	Occupied Bandwidth Measurement	N/A	Refer to Note
15.247(b)	Conducted Power	N/A	Refer to Note
15.247(e)	Power Spectral Density	N/A	Refer to Note
15.203	Antenna Requirement	N/A	Refer to Note

**Note:** Only conducted emission and radiated emission tests had been performed for the addendum. Refer to original report for other test data.

### 2.1 Measurement Uncertainty

Where relevant, the following measurement uncertainty levels have been estimated for tests performed on the EUT as specified in CISPR 16-4-2:

Measurement	Frequency	Expanded Uncertainty (k=2) ( $\pm$ )
Conducted Emissions at mains ports	150 kHz ~ 30 MHz	2.44 dB
Radiated Emissions up to 1 GHz	30 MHz ~ 200 MHz	2.93 dB
	200 MHz ~ 1000 MHz	2.95 dB
Radiated Emissions above 1 GHz	1 GHz ~ 18 GHz	2.26 dB
	18 GHz ~ 40 GHz	1.94 dB

### 2.2 Modification Record

There were no modifications required for compliance.

### 3 General Information

#### 3.1 General Description of EUT

<b>Product</b>	802.11 IoT Module
<b>Brand</b>	AcSiP
<b>Test Model</b>	AI7697HD
<b>Status of EUT</b>	Production Unit
<b>Power Supply Rating</b>	5.0 Vdc (host equipment)
<b>Modulation Type</b>	GFSK
<b>Transfer Rate</b>	1 Mbps
<b>Operating Frequency</b>	2402 ~ 2480 MHz
<b>Number of Channel</b>	40
<b>Antenna Type</b>	Refer to Note as below
<b>Antenna Connector</b>	IPEX-MHF-4
<b>Accessory Device</b>	N/A
<b>Data Cable Supplied</b>	N/A

Note:

1. This report is issued as a supplementary report to BV CPS report no.: RF170818C25. The difference compared with original report is adding new antennas. Therefore, only conducted emission and radiated emission tests had been performed for this report.
2. The antenna information is listed as below.

SKU	Brand	Antenna Type	Model	Antenna Gain (dBi)		
				BT	WLAN 2.4 GHz	WLAN 5 GHz
1	Compal	Coupled	81.EKB15.G14	3.34	3.34	1.44
2		PIFA	DC33002520U	3.46	3.46	5.37

3. The above EUT information is declared by manufacturer and for more detailed features description, please refers to the manufacturer's specifications or User's Manual.

### 3.2 Description of Test Modes

40 channels are provided to this EUT:

Channel	Freq. (MHz)	Channel	Freq. (MHz)	Channel	Freq. (MHz)	Channel	Freq. (MHz)
0	2402	10	2422	20	2442	30	2462
1	2404	11	2424	21	2444	31	2464
2	2406	12	2426	22	2446	32	2466
3	2408	13	2428	23	2448	33	2468
4	2410	14	2430	24	2450	34	2470
5	2412	15	2432	25	2452	35	2472
6	2414	16	2434	26	2454	36	2474
7	2416	17	2436	27	2456	37	2476
8	2418	18	2438	28	2458	38	2478
9	2420	19	2440	29	2460	39	2480

### 3.2.1 Test Mode Applicability and Tested Channel Detail

EUT Configure Mode	Applicable To			Description
	RE $\geq$ 1G	RE $<$ 1G	PLC	
A	√	√	√	SKU 1
B	√	√	√	SKU 2

Where **RE $\geq$ 1G**: Radiated Emission above 1 GHz      **RE $<$ 1G**: Radiated Emission below 1 GHz  
**PLC**: Power Line Conducted Emission

**Note:** The EUT had been pre-tested on the positioned of each 3 axis. The worst case was found when positioned on **X-plane**.  
**Note:** “-” means no effect.

#### **Radiated Emission Test (Above 1 GHz):**

- Pre-Scan has been conducted to determine the worst-case mode from all possible combinations between available modulations, data rates and antenna ports (if EUT with antenna diversity architecture).
- Following channel(s) was (were) selected for the final test as listed below.

EUT Configure Mode	Available Channel	Tested Channel	Modulation Type	Data Rate (Mbps)
A, B	0 to 39	0, 19, 39	GFSK	1

#### **Radiated Emission Test (Below 1 GHz):**

- Pre-Scan has been conducted to determine the worst-case mode from all possible combinations between available modulations, data rates and antenna ports (if EUT with antenna diversity architecture).
- Following channel(s) was (were) selected for the final test as listed below.

EUT Configure Mode	Available Channel	Tested Channel	Modulation Type	Data Rate (Mbps)
A, B	0 to 39	39	GFSK	1

#### **Power Line Conducted Emission Test:**

- Pre-Scan has been conducted to determine the worst-case mode from all possible combinations between available modulations, data rates and antenna ports (if EUT with antenna diversity architecture).
- Following channel(s) was (were) selected for the final test as listed below.

EUT Configure Mode	Available Channel	Tested Channel	Modulation Type	Data Rate (Mbps)
A, B	0 to 39	39	GFSK	1

#### **Test Condition:**

Applicable To	Environmental Conditions	Input Power	Tested by
RE $\geq$ 1G	25 deg. C, 65 % RH	120 Vac, 60 Hz	Jisyong Wang, Thomas Wei
RE $<$ 1G	25 deg. C, 65 % RH	120 Vac, 60 Hz	Jisyong Wang
PLC	25 deg. C, 65 % RH	120 Vac, 60 Hz	Getaz Yang, Jisyong Wang



### 3.3 Description of Support Units

The EUT has been tested as an independent unit together with other necessary accessories or support units. The following support units or accessories were used to form a representative test configuration during the tests.

No.	Product	Brand	Model No.	Serial No.	FCC ID
1.	NB	N/A	N/A	N/A	N/A

No.	Signal Cable Description Of The Above Support Units
1.	N/A

Note:

1. All power cords of the above support units are non-shielded (1.8m).

#### 3.3.1 Configuration of System under Test

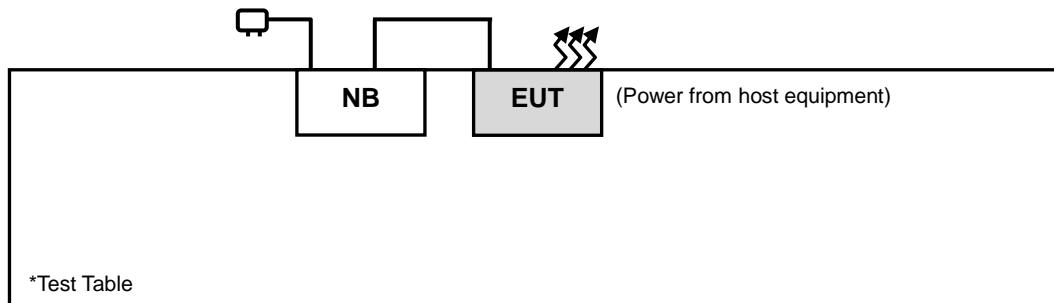

### 3.4 General Description of Applied Standards

The EUT is a RF Product. According to the specifications of the manufacturer, it must comply with the requirements of the following standards:

**FCC Part 15, Subpart C (15.247)**

**KDB 558074 D01 15.247 Meas Guidance v05**

ANSI C63.10-2013

All test items have been performed and recorded as per the above standards.

## 4 Test Types and Results

### 4.1 Radiated Emission and Bandedge Measurement

#### 4.1.1 Limits of Radiated Emission and Bandedge Measurement

Radiated emissions which fall in the restricted bands must comply with the radiated emission limits specified as below table. Other emissions shall be at least 20 dB below the highest level of the desired power:

Frequencies (MHz)	Field Strength (microvolts/meter)	Measurement Distance (meters)
0.009 ~ 0.490	2400/F (kHz)	300
0.490 ~ 1.705	24000/F (kHz)	30
1.705 ~ 30.0	30	30
30 ~ 88	100	3
88 ~ 216	150	3
216 ~ 960	200	3
Above 960	500	3

**Note:**

1. The lower limit shall apply at the transition frequencies.
2. Emission level (dBuV/m) = 20 log Emission level (uV/m).
3. For frequencies above 1000 MHz, the field strength limits are based on average detector, however, the peak field strength of any emission shall not exceed the maximum permitted average limits, specified above by more than 20 dB under any condition of modulation.

## 4.1.2 Test Instruments

Description & Manufacturer	Model No.	Serial No.	Date of Calibration	Due Date of Calibration
Test Receiver Agilent	N9038A	MY51210203	Mar. 16, 2018	Mar. 15, 2019
Spectrum Analyzer Agilent	N9010A	MY52220314	Nov. 24, 2017	Nov. 23, 2018
Spectrum Analyzer ROHDE & SCHWARZ	FSU43	101261	Jan. 11, 2018	Jan. 10, 2019
BILOG Antenna SCHWARZBECK	VULB 9168	9168-472	Dec. 06, 2017	Dec. 05, 2018
Horn Antenna SCHWARZBECK	BBHA 9120D	9120D-969	Dec. 12, 2017	Dec. 11, 2018
HORN Antenna SCHWARZBECK	BBHA 9170	148	Dec. 13, 2017	Dec. 12, 2018
Fixed Attenuator Mini-Circuits	BW-N10W5+	1301	Aug. 13, 2018	Aug. 12, 2019
Loop Antenna	EM-6879	269	Sep. 07, 2018	Sep. 06, 2019
Preamplifier EMCI	EMC001340	980201	Nov. 01, 2017	Oct. 30, 2018
Preamplifier EMCI	EMC 012645	980115	Oct. 20, 2017	Oct. 19, 2018
Preamplifier EMCI	EMC 330H	980112	Oct. 13, 2017	Oct. 12, 2018
Power Meter Anritsu	ML2495A	1012010	Sep. 05, 2018	Sep. 04, 2019
Power Sensor Anritsu	MA2411B	1315050	Sep. 04, 2018	Sep. 03, 2019
RF Coaxial Cable HUBER+SUHNNER	EMC104-SM-SM-8 000&3000	140811+170717	Oct. 20, 2017	Oct. 19, 2018
RF Coaxial Cable HUBER+SUHNNER	SUCOFLEX 104	EMC104-SM-SM-1 000(140807)	Oct. 20, 2017	Oct. 19, 2018
RF Coaxial Cable Worken	8D-FB	Cable-Ch10-01	Oct. 20, 2017	Oct. 19, 2018
Software BV ADT	E3 6.120103	NA	NA	NA
Antenna Tower MF	MFA-440H	NA	NA	NA
Turn Table MF	MFT-201SS	NA	NA	NA
Antenna Tower & Turn Table Controller MF	MF-7802	NA	NA	NA

- Note: 1. The calibration interval of the above test instruments is 12 months and the calibrations are traceable to NML/ROC and NIST/USA.
2. The test was performed in HwaYa Chamber 10.
3. The horn antenna and preamplifier (model: EMC 184045) are used only for the measurement of emission frequency above 1 GHz if tested.
4. The IC Site Registration No. is IC7450F-10.

#### 4.1.3 Test Procedures

##### **For Radiated Emission below 30 MHz**

- a. The EUT was placed on the top of a rotating table 0.8 meters above the ground at a 3 meter chamber room. The table was rotated 360 degrees to determine the position of the highest radiation.
- b. The EUT was set 3 meters away from the interference-receiving antenna, which was mounted on the top of a variable-height antenna tower.
- c. Parallel, perpendicular, and ground-parallel orientations of the antenna are set to make the measurement.
- d. For each suspected emission, the EUT was arranged to its worst case and the rotatable table was turned from 0 degrees to 360 degrees to find the maximum reading.
- e. The test-receiver system was set to Quasi-Peak Detect Function and Specified Bandwidth with Maximum Hold Mode.

##### **Note:**

1. The resolution bandwidth and video bandwidth of test receiver/spectrum analyzer is 9 kHz at frequency below 30 MHz.

##### **For Radiated Emission above 30 MHz**

- a. The EUT was placed on the top of a rotating table 0.8 meters (for 30 MHz ~ 1 GHz) / 1.5 meters (for above 1 GHz) above the ground at 3 meter chamber room for test. The table was rotated 360 degrees to determine the position of the highest radiation.
- b. The EUT was set 3 meters away from the interference-receiving antenna, which was mounted on the top of a variable-height antenna tower.
- c. The height of antenna is varied from one meter to four meters above the ground to determine the maximum value of the field strength. Both horizontal and vertical polarizations of the antenna are set to make the measurement.
- d. For each suspected emission, the EUT was arranged to its worst case and then the antenna was tuned to heights from 1 meter to 4 meters and the rotatable table was turned from 0 degrees to 360 degrees to find the maximum reading.
- e. The test-receiver system was set to quasi-peak detect function and specified bandwidth with maximum hold mode when the test frequency is below 1 GHz.
- f. The test-receiver system was set to peak and average detected function and specified bandwidth with maximum hold mode when the test frequency is above 1 GHz. If the peak reading value also meets average limit, measurement with the average detector is unnecessary.

##### **Note:**

1. The resolution bandwidth and video bandwidth of test receiver/spectrum analyzer is 120 kHz for Quasi-peak detection (QP) at frequency below 1 GHz.
2. The resolution bandwidth of test receiver/spectrum analyzer is 1 MHz and the video bandwidth is 3 MHz for Peak detection (PK) at frequency above 1 GHz.
3. The resolution bandwidth of test receiver/spectrum analyzer is 1 MHz and the video bandwidth is  $\geq 1/T$  (Duty cycle < 98 %) or 10 Hz (Duty cycle  $\geq 98$  %) for Average detection (AV) at frequency above 1 GHz. (RBW = 1 MHz, VBW = 3 kHz)
4. All modes of operation were investigated and the worst-case emissions are reported.

#### 4.1.4 Deviation from Test Standard

No deviation.

#### 4.1.5 Test Set Up

##### <Radiated Emission below 30 MHz>

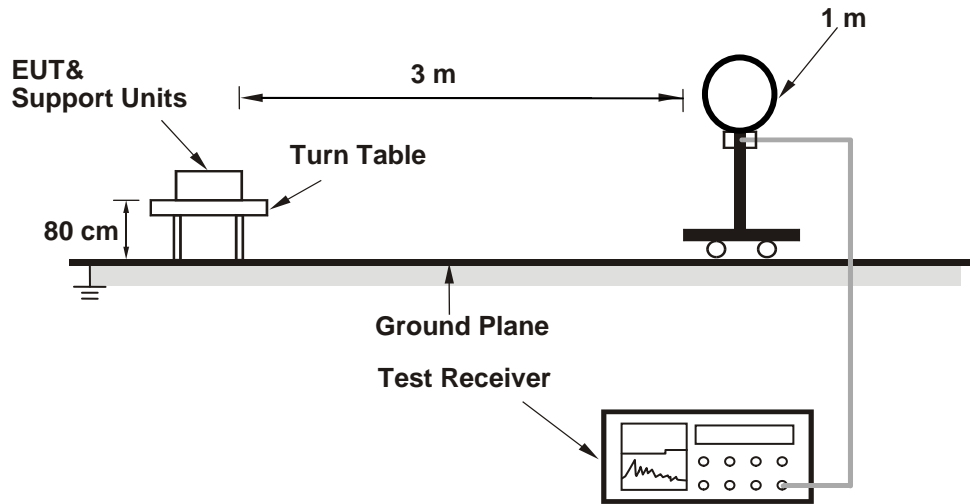

##### <Radiated Emission 30 MHz to 1 GHz>

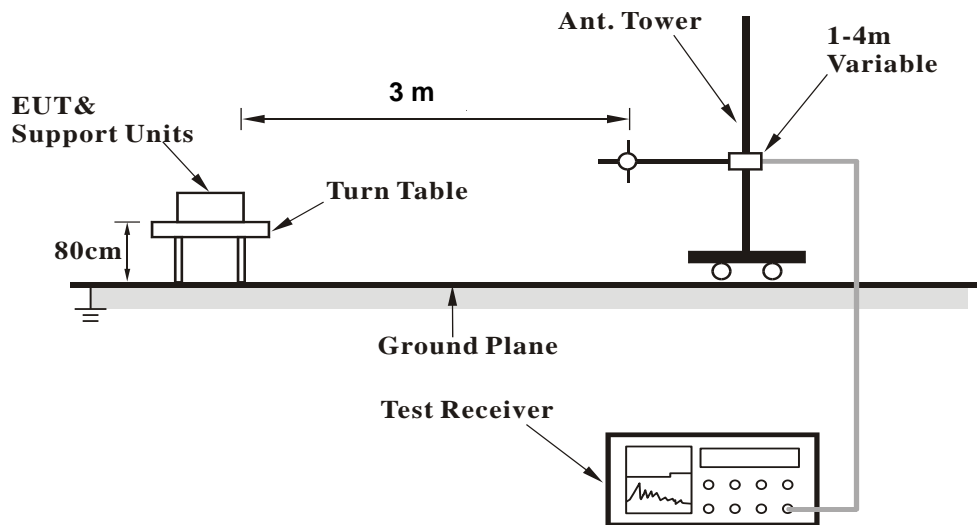

**<Radiated Emission above 1 GHz>**

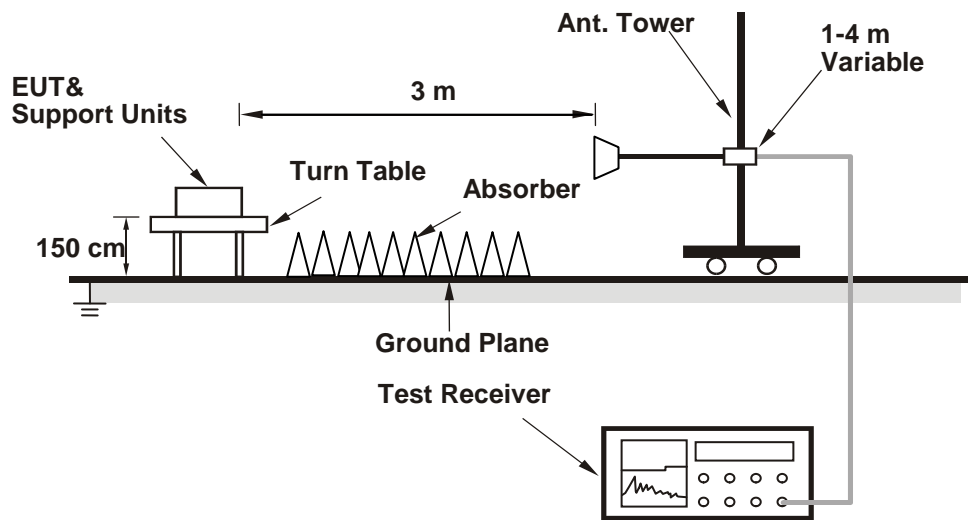

For the actual test configuration, please refer to the attached file (Test Setup Photo).

**4.1.6 EUT Operating Conditions**

- a. Placed the EUT on the testing table.
- b. Set the EUT under transmission condition continuously at specific channel frequency.

4.1.7 Test Results

**Above 1 GHz Data:**  
**Mode A**

EUT Test Condition		Measurement Detail	
Channel	Channel 0	Frequency Range	1 GHz ~ 25 GHz
Input Power	120 Vac, 60 Hz	Detector Function	Peak (PK) Average (AV)
Environmental Conditions	25 deg. C, 65 % RH	Tested By	Jisyong Wang

Antenna Polarity & Test Distance: Horizontal at 3 m										
Frequency (MHz)	Emission Level (dBuV/m)	Read Level (dBuV)	Limit (dBuV/m)	Margin (dB)	Antenna Factor (dB/m)	Cable Loss (dB)	Preamp Factor (dB)	Antenna Height (cm)	Table Angle (Degree)	Remark
2343.84	35.58	57.87	54	-18.42	26.77	4.79	53.85	101	244	Average
2343.84	47.99	54.4	74	-26.01	26.77	4.31	37.49	101	244	Peak
2402	101.94	108.18			26.91	4.37	37.52	101	244	Average
2402	102.83	109.07			26.91	4.37	37.52	101	244	Peak
4804	38.31	53.45	54	-15.69	30.97	6.79	52.9	148	137	Average
4804	45.85	60.99	74	-28.15	30.97	6.79	52.9	148	137	Peak
Antenna Polarity & Test Distance: Vertical at 3 m										
Frequency (MHz)	Emission Level (dBuV/m)	Read Level (dBuV)	Limit (dBuV/m)	Margin (dB)	Antenna Factor (dB/m)	Cable Loss (dB)	Preamp Factor (dB)	Antenna Height (cm)	Table Angle (Degree)	Remark
2342.58	35.24	57.37	54	-18.76	26.77	4.79	53.69	111	273	Average
2342.58	47.07	53.48	74	-26.93	26.77	4.31	37.49	111	273	Peak
2402	95.62	101.86			26.91	4.37	37.52	111	273	Average
2402	96.42	102.66			26.91	4.37	37.52	111	273	Peak
4804	34.42	49.76	54	-19.58	30.97	6.79	53.1	100	265	Average
4804	44.85	60.19	74	-29.15	30.97	6.79	53.1	100	265	Peak

Remarks:

- Emission Level = Read Level + Antenna Factor + Cable Loss - Preamp Factor  
Margin value = Emission level – Limit value
- 2402 MHz: Fundamental frequency.
- The other emission levels were very low against the limit.

EUT Test Condition		Measurement Detail	
Channel	Channel 19	Frequency Range	1 GHz ~ 25 GHz
Input Power	120 Vac, 60 Hz	Detector Function	Peak (PK) Average (AV)
Environmental Conditions	25 deg. C, 65 % RH	Tested By	Jisyong Wang

Antenna Polarity & Test Distance: Horizontal at 3 m										
Frequency (MHz)	Emission Level (dBuV/m)	Read Level (dBuV)	Limit (dBuV/m)	Margin (dB)	Antenna Factor (dB/m)	Cable Loss (dB)	Preamp Factor (dB)	Antenna Height (cm)	Table Angle (Degree)	Remark
2344.29	35.22	57.51	54	-18.78	26.77	4.79	53.85	107	236	Average
2344.29	47.12	53.53	74	-26.88	26.77	4.31	37.49	107	236	Peak
2440	102.16	108.16			27.06	4.4	37.46	107	236	Average
2440	102.92	108.92			27.06	4.4	37.46	107	236	Peak
2485.72	35.92	57.79	54	-18.08	27.15	4.94	53.96	107	236	Average
2485.72	47.82	53.56	74	-26.18	27.15	4.43	37.32	107	236	Peak
4880	38.62	53.56	54	-15.38	31.06	6.86	52.86	115	268	Average
4880	46.63	61.57	74	-27.37	31.06	6.86	52.86	115	268	Peak
Antenna Polarity & Test Distance: Vertical at 3 m										
Frequency (MHz)	Emission Level (dBuV/m)	Read Level (dBuV)	Limit (dBuV/m)	Margin (dB)	Antenna Factor (dB/m)	Cable Loss (dB)	Preamp Factor (dB)	Antenna Height (cm)	Table Angle (Degree)	Remark
2369.22	35.2	57.39	54	-18.8	26.86	4.82	53.87	107	292	Average
2369.22	47.07	53.37	74	-26.93	26.86	4.34	37.5	107	292	Peak
2440	96.34	102.34			27.06	4.4	37.46	107	292	Average
2440	97.13	103.13			27.06	4.4	37.46	107	292	Peak
2496.44	35.77	57.6	54	-18.23	27.2	4.95	53.98	107	292	Average
2496.44	48.15	53.76	74	-25.85	27.2	4.44	37.25	107	292	Peak
4880	35.84	50.78	54	-18.16	31.06	6.86	52.86	170	312	Average
4880	45.24	60.18	74	-28.76	31.06	6.86	52.86	170	312	Peak

Remarks:

- Emission Level = Read Level + Antenna Factor + Cable Loss - Preamp Factor  
Margin value = Emission level – Limit value
- 2440 MHz: Fundamental frequency.
- The other emission levels were very low against the limit.



EUT Test Condition		Measurement Detail	
Channel	Channel 39	Frequency Range	1 GHz ~ 25 GHz
Input Power	120 Vac, 60 Hz	Detector Function	Peak (PK) Average (AV)
Environmental Conditions	25 deg. C, 65 % RH	Tested By	Jisyong Wang

Antenna Polarity & Test Distance: Horizontal at 3 m										
Frequency (MHz)	Emission Level (dBuV/m)	Read Level (dBuV)	Limit (dBuV/m)	Margin (dB)	Antenna Factor (dB/m)	Cable Loss (dB)	Preamp Factor (dB)	Antenna Height (cm)	Table Angle (Degree)	Remark
2480	101.73	107.47			27.15	4.43	37.32	100	237	Average
2480	102.51	108.25			27.15	4.43	37.32	100	237	Peak
2485	40.02	61.89	54	-13.98	27.15	4.94	53.96	100	237	Average
2485	55.25	60.99	74	-18.75	27.15	4.43	37.32	100	237	Peak
4960	39.9	54.76	54	-14.1	31.16	6.9	52.92	115	142	Average
4960	46.7	61.56	74	-27.3	31.16	6.9	52.92	115	142	Peak
Antenna Polarity & Test Distance: Vertical at 3 m										
Frequency (MHz)	Emission Level (dBuV/m)	Read Level (dBuV)	Limit (dBuV/m)	Margin (dB)	Antenna Factor (dB/m)	Cable Loss (dB)	Preamp Factor (dB)	Antenna Height (cm)	Table Angle (Degree)	Remark
2480	96.38	102.12			27.15	4.43	37.32	106	291	Average
2480	97.12	102.86			27.15	4.43	37.32	106	291	Peak
2484.52	38.19	60.06	54	-15.81	27.15	4.94	53.96	106	291	Average
2484.52	53.08	58.82	74	-20.92	27.15	4.43	37.32	106	291	Peak
4960	35.19	50.05	54	-18.81	31.16	6.9	52.92	142	256	Average
4960	45.3	60.16	74	-28.7	31.16	6.9	52.92	142	256	Peak

Remarks:

- Emission Level = Read Level + Antenna Factor + Cable Loss - Preamp Factor  
Margin value = Emission level – Limit value
- 2480 MHz: Fundamental frequency.
- The other emission levels were very low against the limit.

**Mode B**

EUT Test Condition		Measurement Detail	
Channel	Channel 0	Frequency Range	1 GHz ~ 25 GHz
Input Power	120 Vac, 60 Hz	Detector Function	Peak (PK) Average (AV)
Environmental Conditions	25 deg. C, 65 % RH	Tested By	Thomas Wei

Antenna Polarity & Test Distance: Horizontal at 3 m										
Frequency (MHz)	Emission Level (dBuV/m)	Read Level (dBuV)	Limit (dBuV/m)	Margin (dB)	Antenna Factor (dB/m)	Cable Loss (dB)	Preamp Factor (dB)	Antenna Height (cm)	Table Angle (Degree)	Remark
2389.66	36.04	42.02	54	-17.96	27.16	4.36	37.5	141	346	Average
2389.66	48.37	54.35	74	-25.63	27.16	4.36	37.5	141	346	Peak
2402	101.87	107.86			27.16	4.37	37.52	141	346	Average
2402	102.7	108.69			27.16	4.37	37.52	141	346	Peak
4804	35.69	50.66	54	-18.31	31.14	6.79	52.9	155	304	Average
4804	45.02	59.99	74	-28.98	31.14	6.79	52.9	155	304	Peak
Antenna Polarity & Test Distance: Vertical at 3 m										
Frequency (MHz)	Emission Level (dBuV/m)	Read Level (dBuV)	Limit (dBuV/m)	Margin (dB)	Antenna Factor (dB/m)	Cable Loss (dB)	Preamp Factor (dB)	Antenna Height (cm)	Table Angle (Degree)	Remark
2386.3	35.42	41.41	54	-18.58	27.16	4.35	37.5	100	286	Average
2386.3	47.43	53.42	74	-26.57	27.16	4.35	37.5	100	286	Peak
2402	90.17	96.16			27.16	4.37	37.52	100	286	Average
2402	91.02	97.01			27.16	4.37	37.52	100	286	Peak
4804	36.32	51.29	54	-17.68	31.14	6.79	52.9	108	266	Average
4804	45.25	60.22	74	-28.75	31.14	6.79	52.9	108	266	Peak

Remarks:

- Emission Level = Read Level + Antenna Factor + Cable Loss - Preamp Factor  
Margin value = Emission level – Limit value
- 2402 MHz: Fundamental frequency.
- The other emission levels were very low against the limit.

EUT Test Condition		Measurement Detail	
Channel	Channel 19	Frequency Range	1 GHz ~ 25 GHz
Input Power	120 Vac, 60 Hz	Detector Function	Peak (PK) Average (AV)
Environmental Conditions	25 deg. C, 65 % RH	Tested By	Thomas Wei

Antenna Polarity & Test Distance: Horizontal at 3 m										
Frequency (MHz)	Emission Level (dBuV/m)	Read Level (dBuV)	Limit (dBuV/m)	Margin (dB)	Antenna Factor (dB/m)	Cable Loss (dB)	Preamp Factor (dB)	Antenna Height (cm)	Table Angle (Degree)	Remark
2389.38	35.28	41.26	54	-18.72	27.16	4.36	37.5	174	198	Average
2389.38	48.41	54.39	74	-25.59	27.16	4.36	37.5	174	198	Peak
2440	101.12	106.8			27.38	4.4	37.46	174	198	Average
2440	101.94	107.62			27.38	4.4	37.46	174	198	Peak
2496.04	36.26	41.46	54	-17.74	27.61	4.44	37.25	174	198	Average
2496.04	48.3	53.5	74	-25.7	27.61	4.44	37.25	174	198	Peak
4880	35.74	50.49	54	-18.26	31.25	6.86	52.86	151	307	Average
4880	43.63	58.38	74	-30.37	31.25	6.86	52.86	151	307	Peak
Antenna Polarity & Test Distance: Vertical at 3 m										
Frequency (MHz)	Emission Level (dBuV/m)	Read Level (dBuV)	Limit (dBuV/m)	Margin (dB)	Antenna Factor (dB/m)	Cable Loss (dB)	Preamp Factor (dB)	Antenna Height (cm)	Table Angle (Degree)	Remark
2352	35.27	41.43	54	-18.73	27.01	4.32	37.49	100	285	Average
2352	47.18	53.34	74	-26.82	27.01	4.32	37.49	100	285	Peak
2440	92.38	98.06			27.38	4.4	37.46	100	285	Average
2440	93.15	98.83			27.38	4.4	37.46	100	285	Peak
2495.64	36.09	41.29	54	-17.91	27.61	4.44	37.25	100	285	Average
2495.64	47.94	53.14	74	-26.06	27.61	4.44	37.25	100	285	Peak
4880	36.16	50.91	54	-17.84	31.25	6.86	52.86	129	254	Average
4880	43.97	58.72	74	-30.03	31.25	6.86	52.86	129	254	Peak

Remarks:

- Emission Level = Read Level + Antenna Factor + Cable Loss - Preamp Factor  
Margin value = Emission level – Limit value
- 2440 MHz: Fundamental frequency.
- The other emission levels were very low against the limit.

EUT Test Condition		Measurement Detail	
Channel	Channel 39	Frequency Range	1 GHz ~ 25 GHz
Input Power	120 Vac, 60 Hz	Detector Function	Peak (PK) Average (AV)
Environmental Conditions	25 deg. C, 65 % RH	Tested By	Thomas Wei

Antenna Polarity & Test Distance: Horizontal at 3 m										
Frequency (MHz)	Emission Level (dBuV/m)	Read Level (dBuV)	Limit (dBuV/m)	Margin (dB)	Antenna Factor (dB/m)	Cable Loss (dB)	Preamp Factor (dB)	Antenna Height (cm)	Table Angle (Degree)	Remark
2480	103.4	108.76			27.53	4.43	37.32	170	349	Average
2480	104.21	109.57			27.53	4.43	37.32	170	349	Peak
2483.72	41.9	47.26	54	-12.1	27.53	4.43	37.32	170	349	Average
2483.72	57.57	62.93	74	-16.43	27.53	4.43	37.32	170	349	Peak
4960	36.1	50.72	54	-17.9	31.4	6.9	52.92	166	275	Average
4960	43.08	57.7	74	-30.92	31.4	6.9	52.92	166	275	Peak
Antenna Polarity & Test Distance: Vertical at 3 m										
Frequency (MHz)	Emission Level (dBuV/m)	Read Level (dBuV)	Limit (dBuV/m)	Margin (dB)	Antenna Factor (dB/m)	Cable Loss (dB)	Preamp Factor (dB)	Antenna Height (cm)	Table Angle (Degree)	Remark
2480	94.06	99.42			27.53	4.43	37.32	122	283	Average
2480	94.89	100.25			27.53	4.43	37.32	122	283	Peak
2484.72	36.95	42.31	54	-17.05	27.53	4.43	37.32	122	283	Average
2484.72	49.67	55.03	74	-24.33	27.53	4.43	37.32	122	283	Peak
4960	37.18	51.8	54	-16.82	31.4	6.9	52.92	148	181	Average
4960	44.84	59.46	74	-29.16	31.4	6.9	52.92	148	181	Peak

Remarks:

- Emission Level = Read Level + Antenna Factor + Cable Loss - Preamp Factor  
Margin value = Emission level – Limit value
- 2480 MHz: Fundamental frequency.
- The other emission levels were very low against the limit.

**9 kHz ~ 30 MHz Data:**

The amplitude of spurious emissions attenuated more than 20 dB below the permissible value is not required to be report.

**30 MHz ~ 1 GHz Worst-Case Data:**

**Mode A**

EUT Test Condition		Measurement Detail	
Channel	Channel 39	Frequency Range	30 MHz ~ 1 GHz
Input Power	120 Vac, 60 Hz	Detector Function	Peak (PK)
Environmental Conditions	25 deg. C, 65 % RH	Tested By	Jisyong Wang

Antenna Polarity & Test Distance: Horizontal at 3 m										
Frequency (MHz)	Emission Level (dBuV/m)	Read Level (dBuV)	Limit (dBuV/m)	Margin (dB)	Antenna Factor (dB/m)	Cable Loss (dB)	Preamp Factor (dB)	Antenna Height (cm)	Table Angle (Degree)	Remark
90.14	26.1	49.05	43.5	-17.4	8.3	0.71	31.96	106	80	Peak
179.38	28.89	48.77	43.5	-14.61	10.83	1.12	31.83	125	84	Peak
242.43	31.6	50.82	46	-14.4	11.15	1.45	31.82	139	13	Peak
366.59	25.92	41.37	46	-20.08	14.54	1.95	31.94	119	231	Peak
651.77	25.36	34.02	46	-20.64	20.23	3.12	32.01	129	158	Peak
864.2	28.94	33.93	46	-17.06	23.05	3.9	31.94	100	300	Peak
Antenna Polarity & Test Distance: Vertical at 3 m										
Frequency (MHz)	Emission Level (dBuV/m)	Read Level (dBuV)	Limit (dBuV/m)	Margin (dB)	Antenna Factor (dB/m)	Cable Loss (dB)	Preamp Factor (dB)	Antenna Height (cm)	Table Angle (Degree)	Remark
36.79	28.44	45.9	40	-11.56	13.09	0.48	31.03	127	132	Peak
68.8	34.41	54.66	40	-5.59	10.89	0.63	31.77	123	139	Peak
114.39	30.57	51.17	43.5	-12.93	10.46	0.81	31.87	138	134	Peak
239.52	25.82	45.13	46	-20.18	11.03	1.44	31.78	102	124	Peak
530.52	25.58	36.62	46	-20.42	18.02	2.63	31.69	101	225	Peak
821.52	28.43	33.8	46	-17.57	22.5	3.75	31.62	119	356	Peak

Remarks:

1. Emission Level = Read Level + Antenna Factor + Cable Loss - Preamp Factor
2. Margin value = Emission level – Limit value
3. The other emission levels were very low against the limit.

**Mode B**

EUT Test Condition		Measurement Detail	
Channel	Channel 39	Frequency Range	30 MHz ~ 1 GHz
Input Power	120 Vac, 60 Hz	Detector Function	Peak (PK)
Environmental Conditions	25 deg. C, 65 % RH	Tested By	Jisyong Wang

Antenna Polarity & Test Distance: Horizontal at 3 m										
Frequency (MHz)	Emission Level (dBuV/m)	Read Level (dBuV)	Limit (dBuV/m)	Margin (dB)	Antenna Factor (dB/m)	Cable Loss (dB)	Preamp Factor (dB)	Antenna Height (cm)	Table Angle (Degree)	Remark
143.49	33.93	52.14	43.5	-9.57	12.47	0.95	31.63	102	214	Peak
191.99	30.36	50.96	43.5	-13.14	9.91	1.18	31.69	165	285	Peak
288.02	42.38	59.87	46	-3.62	12.6	1.61	31.7	195	241	Peak
480.08	40.89	53.4	46	-5.11	16.93	2.41	31.85	111	162	Peak
673.11	41.16	49.3	46	-4.84	20.49	3.19	31.82	132	285	Peak
816.67	36.52	41.91	46	-9.48	22.44	3.73	31.56	165	285	Peak
Antenna Polarity & Test Distance: Vertical at 3 m										
Frequency (MHz)	Emission Level (dBuV/m)	Read Level (dBuV)	Limit (dBuV/m)	Margin (dB)	Antenna Factor (dB/m)	Cable Loss (dB)	Preamp Factor (dB)	Antenna Height (cm)	Table Angle (Degree)	Remark
44.55	26.15	43.18	40	-13.85	13.6	0.51	31.14	174	185	Peak
288.02	33.18	50.67	46	-12.82	12.6	1.61	31.7	165	295	Peak
480.08	38.67	51.18	46	-7.33	16.93	2.41	31.85	111	152	Peak
577.08	34.15	44.38	46	-11.85	19.08	2.8	32.11	132	265	Peak
746.83	43.06	49.43	46	-2.94	21.48	3.5	31.35	111	185	Peak
912.7	36.34	40.7	46	-9.66	23.58	4.1	32.04	102	162	Peak

Remarks:

1. Emission Level = Read Level + Antenna Factor + Cable Loss - Preamp Factor
2. Margin value = Emission level – Limit value
3. The other emission levels were very low against the limit.

## 4.2 Conducted Emission Measurement

### 4.2.1 Limits of Conducted Emission Measurement

Frequency (MHz)	Conducted Limit (dBUV)	
	Quasi-Peak	Average
0.15 - 0.5	66 - 56	56 - 46
0.50 - 5.0	56	46
5.0 - 30.0	60	50

- Note: 1. The lower limit shall apply at the transition frequencies.  
 2. The limit decreases in line with the logarithm of the frequency in the range of 0.15 to 0.50 MHz.

### 4.2.2 Test Instruments

Description & Manufacturer	Model No.	Serial No.	Date of Calibration	Due Date of Calibration
Test Receiver ROHDE & SCHWARZ	ESCI	100613	Nov. 23, 2017	Nov. 22, 2018
RF signal cable Woken	5D-FB	Cable-cond1-01	Sep. 05, 2018	Sep. 04, 2019
LISN/AMN ROHDE & SCHWARZ (EUT)	ENV216	101826	Feb. 26, 2018	Feb. 25, 2019
LISN/AMN ROHDE & SCHWARZ (Peripheral)	ESH3-Z5	100311	Aug. 19, 2018	Aug. 18, 2019
Software ADT	BV ADT_Cond_ V7.3.7.4	NA	NA	NA

- Note: 1. The calibration interval of the above test instruments is 12 months and the calibrations are traceable to NML/ROC and NIST/USA.  
 2. The test was performed in HwaYa Shielded Room 1.  
 3. The VCCI Site Registration No. is C-2040.

### 4.2.3 Test Procedures

- The EUT was placed 0.4 meters from the conducting wall of the shielded room with EUT being connected to the power mains through a line impedance stabilization network (LISN). Other support units were connected to the power mains through another LISN. The two LISNs provide 50 ohm/50 uH of coupling impedance for the measuring instrument.
- Both lines of the power mains connected to the EUT were checked for maximum conducted interference.
- The frequency range from 150 kHz to 30 MHz was searched. Emission levels under (Limit – 20 dB) was not recorded.

**Note:** The resolution bandwidth and video bandwidth of test receiver is 9 kHz for quasi-peak detection (QP) and average detection (AV) at frequency 0.15 MHz - 30 MHz.

#### 4.2.4 Deviation from Test Standard

No deviation.

#### 4.2.5 Test Setup

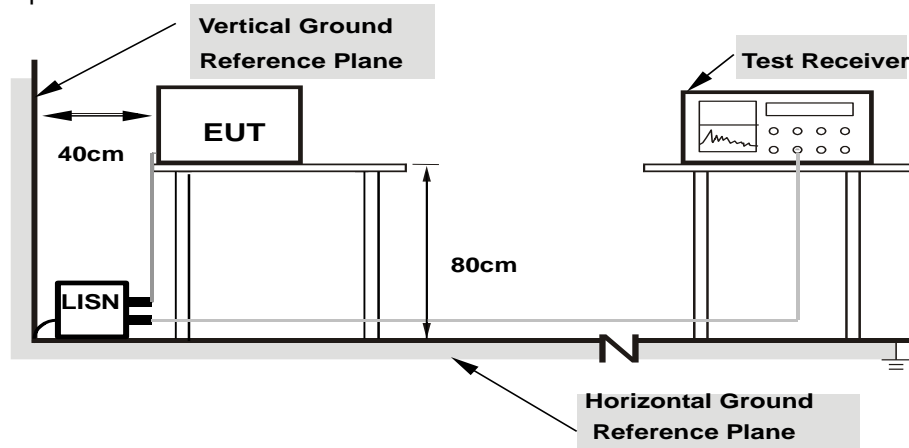

**Note: 1.Support units were connected to second LISN.  
2.Both of LISNs (AMN) are 80 cm from EUT and at least 80  
from other units and other metal planes**

#### 4.2.6 EUT Operating Conditions

- Placed the EUT on the testing table.
- Set the EUT under transmission condition continuously at specific channel frequency.



#### 4.2.7 Test Results

### CONDUCTED WORST-CASE DATA

#### Mode A

Frequency Range	150kHz ~ 30MHz	Detector Function & Resolution Bandwidth	Quasi-Peak (QP) / Average (AV), 9kHz
Input Power	120Vac, 60Hz	Environmental Conditions	25°C, 65%RH
Tested by	Getaz Yang	Test Date	2018/9/9

Phase Of Power : Line (L)										
No	Frequency (MHz)	Correction Factor (dB)	Reading Value (dBuV)		Emission Level (dBuV)		Limit (dBuV)		Margin (dB)	
			Q.P.	AV.	Q.P.	AV.	Q.P.	AV.	Q.P.	AV.
1	0.16190	10.39	34.29	19.43	44.68	29.82	65.37	55.37	-20.69	-25.55
2	0.19400	10.39	28.66	14.84	39.05	25.23	63.86	53.86	-24.81	-28.63
3	0.48957	10.41	11.61	7.17	22.02	17.58	56.18	46.18	-34.16	-28.60
4	1.71400	10.45	4.14	0.34	14.59	10.79	56.00	46.00	-41.41	-35.21
5	4.73400	10.59	6.28	0.32	16.87	10.91	56.00	46.00	-39.13	-35.09
6	23.12600	11.47	6.61	1.81	18.08	13.28	60.00	50.00	-41.92	-36.72

#### Remarks:

1. Q.P. and AV. are abbreviations of quasi-peak and average individually.
2. The emission levels of other frequencies were very low against the limit.
3. Margin value = Emission level – Limit value
4. Correction factor = Insertion loss + Cable loss
5. Emission Level = Correction Factor + Reading Value

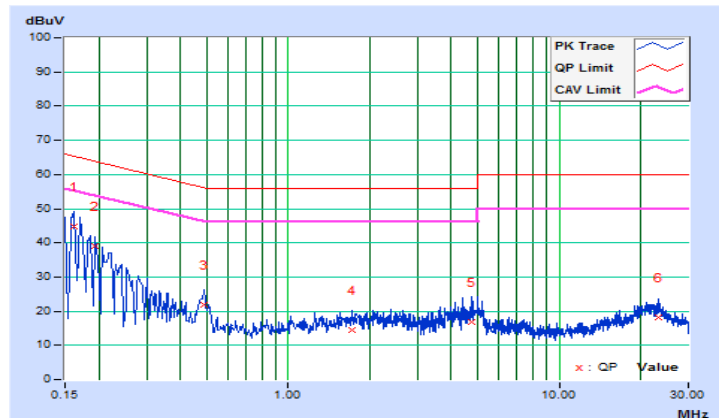

Frequency Range	150kHz ~ 30MHz	Detector Function & Resolution Bandwidth	Quasi-Peak (QP) / Average (AV), 9kHz
Input Power	120Vac, 60Hz	Environmental Conditions	25°C, 65%RH
Tested by	Getaz Yang	Test Date	2018/9/9

Phase Of Power : Neutral (N)										
No	Frequency (MHz)	Correction Factor (dB)	Reading Value (dBuV)		Emission Level (dBuV)		Limit (dBuV)		Margin (dB)	
			Q.P.	AV.	Q.P.	AV.	Q.P.	AV.	Q.P.	AV.
1	0.15800	10.16	34.89	20.42	45.05	30.58	65.57	55.57	-20.52	-24.99
2	0.17801	10.16	31.90	17.79	42.06	27.95	64.58	54.58	-22.52	-26.63
3	0.22985	10.16	24.03	10.41	34.19	20.57	62.46	52.46	-28.27	-31.89
4	0.48957	10.17	14.16	9.44	24.33	19.61	56.18	46.18	-31.85	-26.57
5	4.67800	10.35	8.50	2.03	18.85	12.38	56.00	46.00	-37.15	-33.62
6	20.16200	10.97	6.00	0.86	16.97	11.83	60.00	50.00	-43.03	-38.17

Remarks:

1. Q.P. and AV. are abbreviations of quasi-peak and average individually.
2. The emission levels of other frequencies were very low against the limit.
3. Margin value = Emission level – Limit value
4. Correction factor = Insertion loss + Cable loss
5. Emission Level = Correction Factor + Reading Value

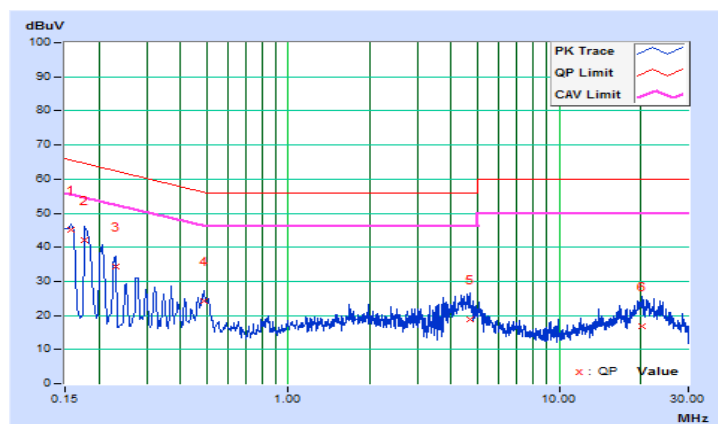

**Mode B**

Frequency Range	150kHz ~ 30MHz	Detector Function & Resolution Bandwidth	Quasi-Peak (QP) / Average (AV), 9kHz
Input Power	120Vac, 60Hz	Environmental Conditions	25°C, 65%RH
Tested by	Jisyong Wang	Test Date	2018/9/9

Phase Of Power : Line (L)										
No	Frequency (MHz)	Correction Factor (dB)	Reading Value (dBuV)		Emission Level (dBuV)		Limit (dBuV)		Margin (dB)	
			Q.P.	AV.	Q.P.	AV.	Q.P.	AV.	Q.P.	AV.
1	0.15782	9.67	36.22	20.44	45.89	30.11	65.58	55.58	-19.69	-25.47
2	0.16569	9.67	34.42	19.43	44.09	29.10	65.17	55.17	-21.08	-26.07
3	0.20243	9.67	28.03	14.03	37.70	23.70	63.51	53.51	-25.81	-29.81
4	0.23211	9.67	23.65	10.16	33.32	19.83	62.37	52.37	-29.05	-32.54
5	0.25557	9.67	20.11	7.20	29.78	16.87	61.57	51.57	-31.79	-34.70
6	23.98927	9.91	21.43	7.95	31.34	17.86	60.00	50.00	-28.66	-32.14

Remarks:

1. Q.P. and AV. are abbreviations of quasi-peak and average individually.
2. The emission levels of other frequencies were very low against the limit.
3. Margin value = Emission level – Limit value
4. Correction factor = Insertion loss + Cable loss
5. Emission Level = Correction Factor + Reading Value

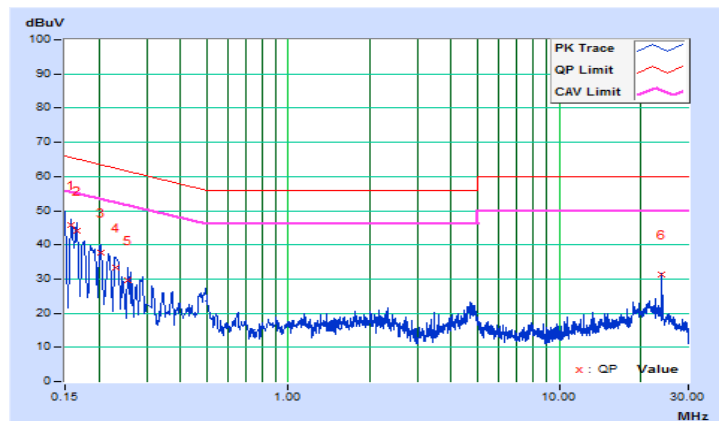

Frequency Range	150kHz ~ 30MHz	Detector Function & Resolution Bandwidth	Quasi-Peak (QP) / Average (AV), 9kHz
Input Power	120Vac, 60Hz	Environmental Conditions	25°C, 65%RH
Tested by	Jisyong Wang	Test Date	2018/9/9

Phase Of Power : Neutral (N)										
No	Frequency (MHz)	Correction Factor (dB)	Reading Value (dBuV)		Emission Level (dBuV)		Limit (dBuV)		Margin (dB)	
			Q.P.	AV.	Q.P.	AV.	Q.P.	AV.	Q.P.	AV.
1	0.15719	9.68	35.09	19.36	44.77	29.04	65.61	55.61	-20.84	-26.57
2	0.19301	9.67	29.33	15.11	39.00	24.78	63.91	53.91	-24.91	-29.13
3	0.21647	9.67	25.47	12.05	35.14	21.72	62.95	52.95	-27.81	-31.23
4	0.48935	9.67	15.89	3.94	25.56	13.61	56.18	46.18	-30.62	-32.57
5	4.45882	9.74	12.77	0.34	22.51	10.08	56.00	46.00	-33.49	-35.92
6	23.99318	10.03	19.72	7.35	29.75	17.38	60.00	50.00	-30.25	-32.62

Remarks:

1. Q.P. and AV. are abbreviations of quasi-peak and average individually.
2. The emission levels of other frequencies were very low against the limit.
3. Margin value = Emission level – Limit value
4. Correction factor = Insertion loss + Cable loss
5. Emission Level = Correction Factor + Reading Value

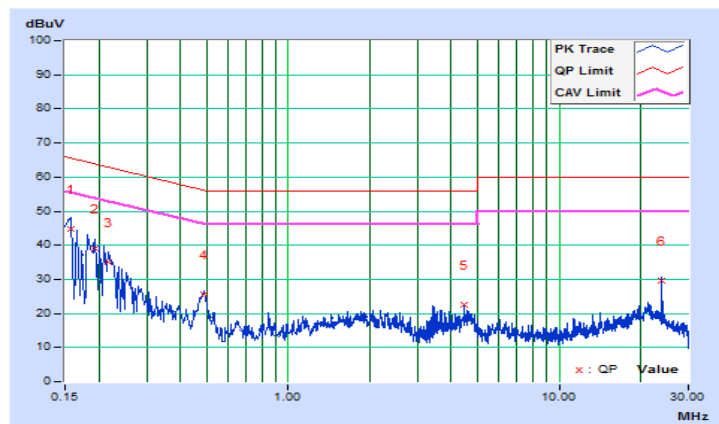

## 5 Pictures of Test Arrangements

Please refer to the attached file (Test Setup Photo).

## Appendix – Information on the Testing Laboratories

We, Bureau Veritas Consumer Products Services (H.K.) Ltd., Taoyuan Branch, were founded in 1988 to provide our best service in EMC, Radio, Telecom and Safety consultation. Our laboratories are FCC recognized accredited test firms and accredited according to ISO/IEC 17025.

If you have any comments, please feel free to contact us at the following:

**Linko EMC/RF Lab**

Tel: 886-2-26052180

Fax: 886-2-26051924

**Hsin Chu EMC/RF/Telecom Lab**

Tel: 886-3-6668565

Fax: 886-3-6668323

**Hwa Ya EMC/RF/Safety**

Tel: 886-3-3183232

Fax: 886-3-3270892

**Email:** [service.adt@tw.bureauveritas.com](mailto:service.adt@tw.bureauveritas.com)

**Web Site:** [www.bureauveritas-adt.com](http://www.bureauveritas-adt.com)

The address and road map of all our labs can be found in our web site also.

--- END ---