

## Variant FCC Test Report

**Report No.:** RF170818C25B-1

**FCC ID:** 2ADWC-AI7697HD

**Test Model:** AI7697HD

**Received Date:** Aug. 30, 2018

**Test Date:** Sep. 06, 2018 ~ Sep. 18, 2018

**Issued Date:** Sep. 21, 2018

**Applicant:** AcSiP Technology Corporation

**Address:** 3F.-1, No.207, Fusing Rd., Taoyuan Dist., Taoyuan County 330, Taiwan  
(R.O.C.)

**Issued By:** Bureau Veritas Consumer Products Services (H.K.) Ltd., Taoyuan Branch

**Lab Address:** No. 47-2, 14th Ling, Chia Pau Vil., Lin Kou Dist., New Taipei City, Taiwan  
( R.O.C )

**Test Location:** No.19, Hwa Ya 2nd Rd., Wen Hwa Vil., Kwei Shan Dist., Taoyuan City  
33383, Taiwan, R.O.C.

**FCC Registration /  
Designation Number:** 788550 / TW0003



This report is for your exclusive use. Any copying or replication of this report to or for any other person or entity, or use of our name or trademark, is permitted only with our prior written permission. This report sets forth our findings solely with respect to the test samples identified herein. The results set forth in this report are not indicative or representative of the quality or characteristics of the lot from which a test sample was taken or any similar or identical product unless specifically and expressly noted. Our report includes all of the tests requested by you and the results thereof based upon the information that you provided to us. You have 60 days from date of issuance of this report to notify us of any material error or omission caused by our negligence, provided, however, that such notice shall be in writing and shall specifically address the issue you wish to raise. A failure to raise such issue within the prescribed time shall constitute your unqualified acceptance of the completeness of this report, the tests conducted and the correctness of the report contents. Unless specific mention, the uncertainty of measurement has been explicitly taken into account to declare the compliance or non-compliance to the specification. The report must not be used by the client to claim product certification, approval, or endorsement by TAF or any government agencies.

## Table of Contents

<b>Release Control Record .....</b>	<b>3</b>
<b>1 Certificate of Conformity .....</b>	<b>4</b>
<b>2 Summary of Test Results.....</b>	<b>5</b>
2.1 Measurement Uncertainty.....	5
2.2 Modification Record .....	5
<b>3 General Information .....</b>	<b>6</b>
3.1 General Description of EUT .....	6
3.2 Description of Test Modes.....	7
3.2.1 Test Mode Applicability and Tested Channel Detail.....	8
3.3 Description of Support Units .....	9
3.3.1 Configuration of System under Test .....	9
3.4 General Description of Applied Standards.....	9
<b>4 Test Types and Results .....</b>	<b>10</b>
4.1 Radiated Emission and Bandedge Measurement .....	10
4.1.1 Limits of Radiated Emission and Bandedge Measurement .....	10
4.1.2 Test Instruments .....	11
4.1.3 Test Procedures.....	12
4.1.4 Deviation from Test Standard .....	13
4.1.5 Test Set Up .....	13
4.1.6 EUT Operating Conditions.....	14
4.1.7 Test Results .....	15
4.2 Conducted Emission Measurement.....	41
4.2.1 Limits of Conducted Emission Measurement .....	41
4.2.2 Test Instruments .....	41
4.2.3 Test Procedures.....	42
4.2.4 Deviation from Test Standard .....	42
4.2.5 Test Setup.....	42
4.2.6 EUT Operating Conditions.....	42
4.2.7 Test Results .....	43
<b>5 Pictures of Test Arrangements.....</b>	<b>47</b>
<b>Appendix – Information on the Testing Laboratories .....</b>	<b>48</b>

### Release Control Record

Issue No.	Description	Date Issued
RF170818C25B-1	Original Release	Sep. 21, 2018

## 1 Certificate of Conformity

**Product:** 802.11 IoT Module

**Brand:** AcSiP

**Test Model:** AI7697HD

**Sample Status:** Production Unit

**Applicant:** AcSiP Technology Corporation

**Test Date:** Sep. 06, 2018 ~ Sep. 18, 2018

**Standards:** 47 CFR FCC Part 15, Subpart C (Section 15.247)  
ANSI C63.10:2013

This report is issued as a supplementary report to BV CPS report no.: RF170818C25-1. This report shall be used by combining with its original report.

**Prepared by :** , **Date:** Sep. 21, 2018  
Gina Liu / Specialist

**Approved by :** , **Date:** Sep. 21, 2018  
Dylan Chiou / Project Engineer

## 2 Summary of Test Results

47 CFR FCC Part 15, Subpart C (Section 15.247)			
FCC Clause	Test Item	Result	Remarks
15.207	AC Power Conducted Emission	Pass	Meet the requirement of limit. Minimum passing margin is -19.81 dB at 0.15400 MHz and 0.15391 MHz.
15.205 / 15.209 / 15.247(d)	Radiated Emissions and Band Edge Measurement	Pass	Meet the requirement of limit. Minimum passing margin is -0.1 dB at 4924 MHz.
15.247(d)	Antenna Port Emission	N/A	Refer to Note
15.247(a)(2)	6 dB Bandwidth	N/A	Refer to Note
---	Occupied Bandwidth Measurement	N/A	Refer to Note
15.247(b)	Conducted power	N/A	Refer to Note
15.247(e)	Power Spectral Density	N/A	Refer to Note
15.203	Antenna Requirement	N/A	Refer to Note

**Note:** Only conducted emission and radiated emission tests had been performed for the addendum. Refer to original report for other test data.

### 2.1 Measurement Uncertainty

Where relevant, the following measurement uncertainty levels have been estimated for tests performed on the EUT as specified in CISPR 16-4-2:

Measurement	Frequency	Expanded Uncertainty (k=2) (±)
Conducted Emissions at mains ports	150 kHz ~ 30 MHz	2.44 dB
Radiated Emissions up to 1 GHz	30 MHz ~ 200 MHz	2.93 dB
	200 MHz ~ 1000 MHz	2.95 dB
Radiated Emissions above 1 GHz	1 GHz ~ 18 GHz	2.26 dB
	18 GHz ~ 40 GHz	1.94 dB

### 2.2 Modification Record

There were no modifications required for compliance.

### 3 General Information

#### 3.1 General Description of EUT

<b>Product</b>	802.11 IoT Module
<b>Brand</b>	AcSiP
<b>Test Model</b>	AI7697HD
<b>Status of EUT</b>	Production Unit
<b>Power Supply Rating</b>	5.0 Vdc (host equipment)
<b>Modulation Type</b>	CCK, DQPSK, DBPSK for DSSS 64QAM, 16QAM, QPSK, BPSK for OFDM
<b>Modulation Technology</b>	DSSS, OFDM
<b>Transfer Rate</b>	802.11b: 11.0 / 5.5 / 2.0 / 1.0 Mbps 802.11g: 54.0 / 48.0 / 36.0 / 24.0 / 18.0 / 12.0 / 9.0 / 6.0 Mbps 802.11n: up to 150.0 Mbps
<b>Operating Frequency</b>	2412 ~ 2462 MHz
<b>Number of Channel</b>	11 for 802.11b, 802.11g, 802.11n (HT20) 7 for 802.11n (HT40)
<b>Antenna Type</b>	Refer to Note as below
<b>Antenna Connector</b>	IPEX-MHF-4
<b>Accessory Device</b>	N/A
<b>Data Cable Supplied</b>	N/A

Note:

1. This report is issued as a supplementary report to BV CPS report no.: RF170818C25-1. The difference compared with original report is adding new antennas. Therefore, only conducted emission and radiated emission tests had been performed for this report.
2. The antenna information is listed as below.

SKU	Brand	Antenna Type	Model	Antenna Gain (dBi)		
				BT	WLAN 2.4 GHz	WLAN 5 GHz
1	Compal	Coupled	81.EKB15.G14	3.34	3.34	1.44
2		PIFA	DC33002520U	3.46	3.46	5.37

3. The above EUT information is declared by manufacturer and for more detailed features description, please refers to the manufacturer's specifications or user's manual.

### 3.2 Description of Test Modes

11 channels are provided for 802.11b, 802.11g and 802.11n (HT20):

Channel	Frequency (MHz)	Channel	Frequency (MHz)
1	2412	7	2442
2	2417	8	2447
3	2422	9	2452
4	2427	10	2457
5	2432	11	2462
6	2437		

7 channels are provided for 802.11n (HT40):

Channel	Frequency (MHz)	Channel	Frequency (MHz)
3	2422	7	2442
4	2427	8	2447
5	2432	9	2452
6	2437		

### 3.2.1 Test Mode Applicability and Tested Channel Detail

EUT Configure Mode	Applicable To			Description
	RE $\geq$ 1G	RE $<$ 1G	PLC	
A	√	√	√	SKU 1
B	√	√	√	SKU 2

Where **RE $\geq$ 1G**: Radiated Emission above 1 GHz      **RE $<$ 1G**: Radiated Emission below 1 GHz  
**PLC**: Power Line Conducted Emission

**NOTE:** The EUT had been pre-tested on the positioned of each 3 axis. The worst case was found when positioned on **Y-plane**.  
**NOTE:** “-” means no effect.

#### **Radiated Emission Test (Above 1 GHz):**

- Pre-Scan has been conducted to determine the worst-case mode from all possible combinations between available modulations, data rates and antenna ports (if EUT with antenna diversity architecture).
- Following channel(s) was (were) selected for the final test as listed below.

EUT Configure Mode	Mode	Available Channel	Tested Channel	Modulation Technology	Modulation Type	Data Rate (Mbps)
A, B	802.11b	1 to 11	1, 6, 11	DSSS	DBPSK	1.0
	802.11g	1 to 11	1, 6, 11	OFDM	BPSK	6.0
	802.11n (HT20)	1 to 11	1, 6, 11	OFDM	BPSK	6.5
	802.11n (HT40)	3 to 9	3, 6, 9	OFDM	BPSK	13.5

#### **Radiated Emission Test (Below 1 GHz):**

- Pre-Scan has been conducted to determine the worst-case mode from all possible combinations between available modulations, data rates and antenna ports (if EUT with antenna diversity architecture).
- Following channel(s) was (were) selected for the final test as listed below.

EUT Configure Mode	Mode	Available Channel	Tested Channel	Modulation Technology	Modulation Type	Data Rate (Mbps)
A	802.11n (HT40)	3 to 9	9	OFDM	BPSK	13.5
B	802.11b	1 to 11	11	DSSS	DBPSK	1.0

#### **Power Line Conducted Emission Test:**

- Pre-Scan has been conducted to determine the worst-case mode from all possible combinations between available modulations, data rates and antenna ports (if EUT with antenna diversity architecture).
- Following channel(s) was (were) selected for the final test as listed below.

EUT Configure Mode	Mode	Available Channel	Tested Channel	Modulation Technology	Modulation Type	Data Rate (Mbps)
A	802.11n (HT40)	3 to 9	9	OFDM	BPSK	13.5
B	802.11b	1 to 11	11	DSSS	DBPSK	1.0



**Test Condition:**

Applicable To	Environmental Conditions	Input Power	Tested by
RE≥1G	25 deg. C, 65 % RH	120 Vac, 60 Hz	Gavin Wu, Thomas Wei
RE<1G	25 deg. C, 65 % RH	120 Vac, 60 Hz	Jisyong Wang
PLC	25 deg. C, 65 % RH	120 Vac, 60 Hz	Getaz Yang, Jisyong Wang

**3.3 Description of Support Units**

The EUT has been tested as an independent unit together with other necessary accessories or support units. The following support units or accessories were used to form a representative test configuration during the tests.

No.	Product	Brand	Model No.	Serial No.	FCC ID
1.	NB	N/A	N/A	N/A	N/A

No.	Signal Cable Description Of The Above Support Units
1.	N/A

Note:

1. All power cords of the above support units are non-shielded (1.8m).

**3.3.1 Configuration of System under Test**

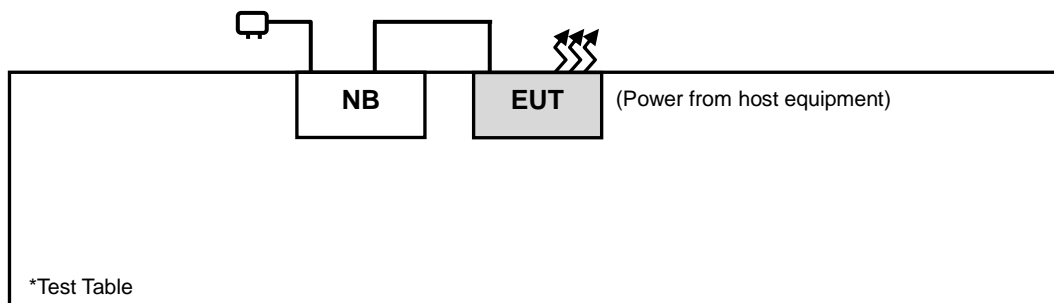

**3.4 General Description of Applied Standards**

The EUT is a RF Product. According to the specifications of the manufacturer, it must comply with the requirements of the following standards:

**FCC Part 15, Subpart C (15.247)**

**KDB 558074 D01 15.247 Meas Guidance v05**

ANSI C63.10-2013

All test items have been performed and recorded as per the above standards.

## 4 Test Types and Results

### 4.1 Radiated Emission and Bandedge Measurement

#### 4.1.1 Limits of Radiated Emission and Bandedge Measurement

Radiated emissions which fall in the restricted bands must comply with the radiated emission limits specified as below table. Other emissions shall be at least 20 dB below the highest level of the desired power:

Frequencies (MHz)	Field Strength (microvolts/meter)	Measurement Distance (meters)
0.009 ~ 0.490	2400/F (kHz)	300
0.490 ~ 1.705	24000/F (kHz)	30
1.705 ~ 30.0	30	30
30 ~ 88	100	3
88 ~ 216	150	3
216 ~ 960	200	3
Above 960	500	3

**NOTE:**

1. The lower limit shall apply at the transition frequencies.
2. Emission level (dBuV/m) = 20 log Emission level (uV/m).
3. For frequencies above 1000 MHz, the field strength limits are based on average detector, however, the peak field strength of any emission shall not exceed the maximum permitted average limits, specified above by more than 20 dB under any condition of modulation.

## 4.1.2 Test Instruments

Description & Manufacturer	Model No.	Serial No.	Date of Calibration	Due Date of Calibration
Test Receiver Agilent	N9038A	MY51210203	Mar. 16, 2018	Mar. 15, 2019
Spectrum Analyzer Agilent	N9010A	MY52220314	Nov. 24, 2017	Nov. 23, 2018
Spectrum Analyzer ROHDE & SCHWARZ	FSU43	101261	Jan. 11, 2018	Jan. 10, 2019
BILOG Antenna SCHWARZBECK	VULB 9168	9168-472	Dec. 06, 2017	Dec. 05, 2018
Horn Antenna SCHWARZBECK	BBHA 9120D	9120D-969	Dec. 12, 2017	Dec. 11, 2018
HORN Antenna SCHWARZBECK	BBHA 9170	148	Dec. 13, 2017	Dec. 12, 2018
Fixed Attenuator Mini-Circuits	BW-N10W5+	1301	Aug. 13, 2018	Aug. 12, 2019
Loop Antenna	EM-6879	269	Sep. 07, 2018	Sep. 06, 2019
Preamplifier EMCI	EMC001340	980201	Nov. 01, 2017	Oct. 30, 2018
Preamplifier EMCI	EMC 012645	980115	Oct. 20, 2017	Oct. 19, 2018
Preamplifier EMCI	EMC 330H	980112	Oct. 13, 2017	Oct. 12, 2018
Power Meter Anritsu	ML2495A	1012010	Sep. 05, 2018	Sep. 04, 2019
Power Sensor Anritsu	MA2411B	1315050	Sep. 04, 2018	Sep. 03, 2019
RF Coaxial Cable HUBER+SUHNNER	EMC104-SM-SM-8 000&3000	140811+170717	Oct. 20, 2017	Oct. 19, 2018
RF Coaxial Cable HUBER+SUHNNER	SUCOFLEX 104	EMC104-SM-SM-1 000(140807)	Oct. 20, 2017	Oct. 19, 2018
RF Coaxial Cable Worken	8D-FB	Cable-Ch10-01	Oct. 20, 2017	Oct. 19, 2018
Software BV ADT	E3 6.120103	NA	NA	NA
Antenna Tower MF	MFA-440H	NA	NA	NA
Turn Table MF	MFT-201SS	NA	NA	NA
Antenna Tower & Turn Table Controller MF	MF-7802	NA	NA	NA

- Note: 1. The calibration interval of the above test instruments is 12 months and the calibrations are traceable to NML/ROC and NIST/USA.
2. The test was performed in HwaYa Chamber 10.
3. The horn antenna and preamplifier (model: EMC 184045) are used only for the measurement of emission frequency above 1 GHz if tested.
4. The IC Site Registration No. is IC7450F-10.

#### 4.1.3 Test Procedures

##### **For Radiated Emission below 30 MHz**

- a. The EUT was placed on the top of a rotating table 0.8 meters above the ground at a 3 meter chamber room. The table was rotated 360 degrees to determine the position of the highest radiation.
- b. The EUT was set 3 meters away from the interference-receiving antenna, which was mounted on the top of a variable-height antenna tower.
- c. Parallel, perpendicular, and ground-parallel orientations of the antenna are set to make the measurement.
- d. For each suspected emission, the EUT was arranged to its worst case and the rotatable table was turned from 0 degrees to 360 degrees to find the maximum reading.
- e. The test-receiver system was set to Quasi-Peak Detect Function and Specified Bandwidth with Maximum Hold Mode.

##### **Note:**

1. The resolution bandwidth and video bandwidth of test receiver/spectrum analyzer is 9 kHz at frequency below 30 MHz.

##### **For Radiated Emission above 30 MHz**

- a. The EUT was placed on the top of a rotating table 0.8 meters (for 30 MHz ~ 1 GHz) / 1.5 meters (for above 1 GHz) above the ground at 3 meter chamber room for test. The table was rotated 360 degrees to determine the position of the highest radiation.
- b. The EUT was set 3 meters away from the interference-receiving antenna, which was mounted on the top of a variable-height antenna tower.
- c. The height of antenna is varied from one meter to four meters above the ground to determine the maximum value of the field strength. Both horizontal and vertical polarizations of the antenna are set to make the measurement.
- d. For each suspected emission, the EUT was arranged to its worst case and then the antenna was tuned to heights from 1 meter to 4 meters and the rotatable table was turned from 0 degrees to 360 degrees to find the maximum reading.
- e. The test-receiver system was set to quasi-peak detect function and specified bandwidth with maximum hold mode when the test frequency is below 1 GHz.
- f. The test-receiver system was set to peak and average detected function and specified bandwidth with maximum hold mode when the test frequency is above 1 GHz. If the peak reading value also meets average limit, measurement with the average detector is unnecessary.

##### **Note:**

1. The resolution bandwidth and video bandwidth of test receiver/spectrum analyzer is 120 kHz for Quasi-peak detection (QP) at frequency below 1 GHz.
2. The resolution bandwidth of test receiver/spectrum analyzer is 1 MHz and the video bandwidth is 3 MHz for Peak detection (PK) at frequency above 1 GHz.
3. The resolution bandwidth of test receiver/spectrum analyzer is 1 MHz and the video bandwidth is  $\geq 1/T$  (Duty cycle < 98 %) or 10 Hz (Duty cycle  $\geq 98$  %) for Average detection (AV) at frequency above 1 GHz.  
(11b: RBW = 1 MHz, VBW = 10 Hz ; 11g: RBW = 1 MHz, VBW = 10 Hz ;  
11n (HT20): RBW = 1 MHz, VBW = 10 Hz ; 11n (HT40): RBW = 1 MHz, VBW = 10 Hz)
4. All modes of operation were investigated and the worst-case emissions are reported.

4.1.4 Deviation from Test Standard

No deviation.

4.1.5 Test Set Up

<Radiated Emission below 30 MHz>

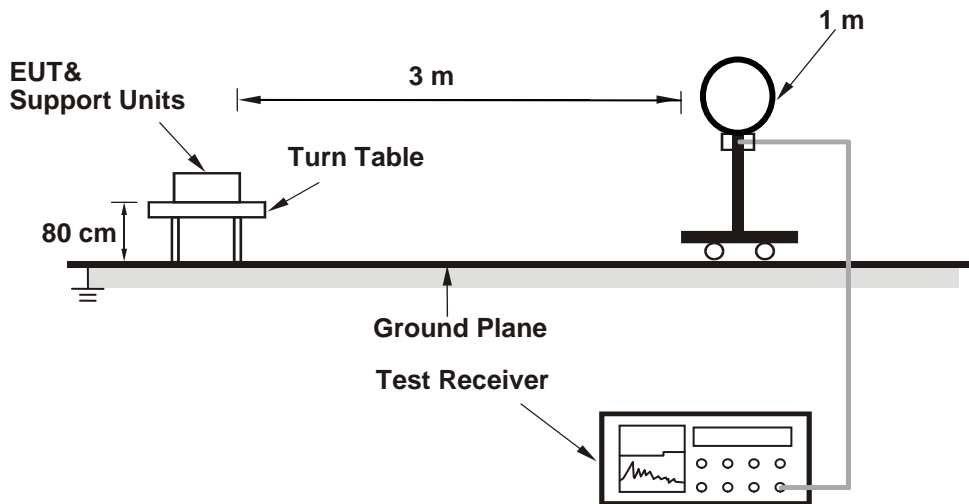

<Radiated Emission 30 MHz to 1 GHz>

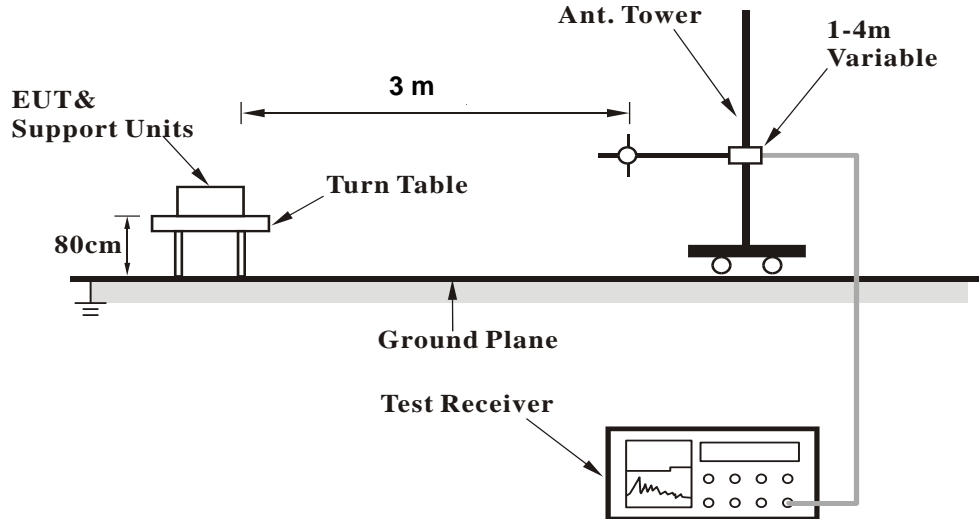

**<Radiated Emission above 1 GHz>**

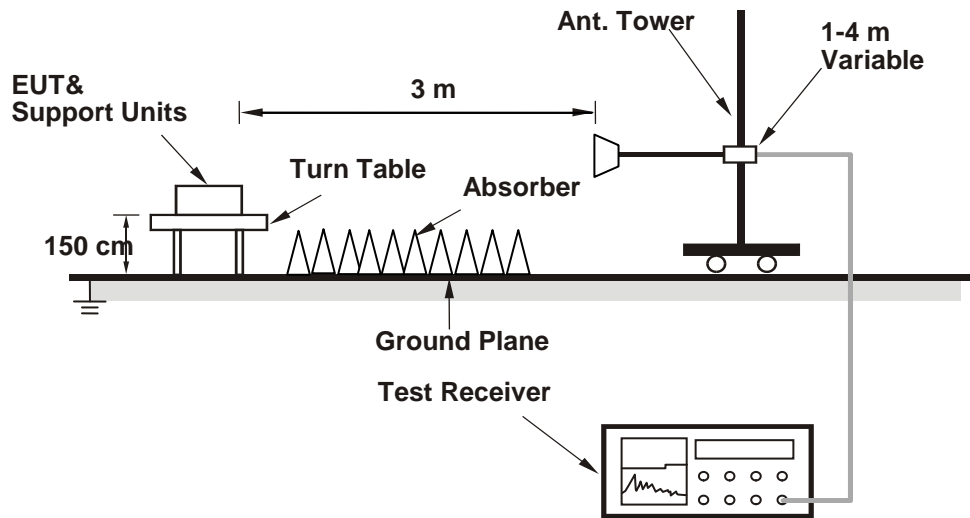

For the actual test configuration, please refer to the attached file (Test Setup Photo).

**4.1.6 EUT Operating Conditions**

- a. Placed the EUT on a testing table.
- b. Use the software to control the EUT under transmission condition continuously at specific channel frequency.

4.1.7 Test Results

Above 1 GHz Data :  
 Mode A  
 802.11b

EUT Test Condition		Measurement Detail	
Channel	Channel 1	Frequency Range	1 GHz ~ 25 GHz
Input Power	120 Vac, 60 Hz	Detector Function	Peak (PK) Average (AV)
Environmental Conditions	25 deg. C, 65 % RH	Tested By	Gavin Wu

Antenna Polarity & Test Distance: Horizontal at 3 m										
Frequency (MHz)	Emission Level (dBuV/m)	Read Level (dBuV)	Limit (dBuV/m)	Margin (dB)	Antenna Factor (dB/m)	Cable Loss (dB)	Preamp Factor (dB)	Antenna Height (cm)	Table Angle (Degree)	Remark
2386.32	52.94	75.06	54	-1.06	26.91	4.84	53.87	167	236	Average
2386.32	60.2	66.44	74	-13.8	26.91	4.35	37.5	167	236	Peak
2412	103.28	109.46			26.96	4.38	37.52	167	236	Average
2412	107.16	113.34			26.96	4.38	37.52	167	236	Peak
4824	45.54	60.63	54	-8.46	30.99	6.81	52.89	100	30	Average
4824	49.48	64.57	74	-24.52	30.99	6.81	52.89	100	30	Peak
Antenna Polarity & Test Distance: Vertical at 3 m										
Frequency (MHz)	Emission Level (dBuV/m)	Read Level (dBuV)	Limit (dBuV/m)	Margin (dB)	Antenna Factor (dB/m)	Cable Loss (dB)	Preamp Factor (dB)	Antenna Height (cm)	Table Angle (Degree)	Remark
2386.14	47.26	69.38	54	-6.74	26.91	4.84	53.87	100	86	Average
2386.14	55.19	61.43	74	-18.81	26.91	4.35	37.5	100	86	Peak
2412	99.94	106.12			26.96	4.38	37.52	100	86	Average
2412	103.82	110			26.96	4.38	37.52	100	86	Peak
4824	41.28	56.37	54	-12.72	30.99	6.81	52.89	100	276	Average
4824	47.68	62.77	74	-26.32	30.99	6.81	52.89	100	276	Peak

Remarks:

- Emission Level = Read Level + Antenna Factor + Cable Loss - Preamp Factor  
 Margin value = Emission level – Limit value
- 2412 MHz: Fundamental frequency.
- The other emission levels were very low against the limit.

EUT Test Condition		Measurement Detail	
Channel	Channel 6	Frequency Range	1 GHz ~ 25 GHz
Input Power	120 Vac, 60 Hz	Detector Function	Peak (PK) Average (AV)
Environmental Conditions	25 deg. C, 65 % RH	Tested By	Gavin Wu

Antenna Polarity & Test Distance: Horizontal at 3 m										
Frequency (MHz)	Emission Level (dBuV/m)	Read Level (dBuV)	Limit (dBuV/m)	Margin (dB)	Antenna Factor (dB/m)	Cable Loss (dB)	Preamp Factor (dB)	Antenna Height (cm)	Table Angle (Degree)	Remark
2386.86	37.76	59.88	54	-16.24	26.91	4.84	53.87	183	238	Average
2386.86	51.15	57.38	74	-22.85	26.91	4.36	37.5	183	238	Peak
2437	101.57	107.57			27.06	4.4	37.46	183	238	Average
2437	105.48	111.48			27.06	4.4	37.46	183	238	Peak
2484.56	36.64	58.51	54	-17.36	27.15	4.94	53.96	183	238	Average
2484.56	49.71	55.45	74	-24.29	27.15	4.43	37.32	183	238	Peak
4874	42.53	57.47	54	-11.47	31.06	6.86	52.86	100	51	Average
4874	46.99	61.93	74	-27.01	31.06	6.86	52.86	100	51	Peak
Antenna Polarity & Test Distance: Vertical at 3 m										
Frequency (MHz)	Emission Level (dBuV/m)	Read Level (dBuV)	Limit (dBuV/m)	Margin (dB)	Antenna Factor (dB/m)	Cable Loss (dB)	Preamp Factor (dB)	Antenna Height (cm)	Table Angle (Degree)	Remark
2386.68	36.15	58.27	54	-17.85	26.91	4.84	53.87	100	87	Average
2386.68	49.4	55.63	74	-24.6	26.91	4.36	37.5	100	87	Peak
2437	99.52	105.52			27.06	4.4	37.46	100	87	Average
2437	103.42	109.42			27.06	4.4	37.46	100	87	Peak
2488.32	35.51	57.33	54	-18.49	27.2	4.94	53.96	100	87	Average
2488.32	48.72	54.41	74	-25.28	27.2	4.43	37.32	100	87	Peak
4874	37.66	52.6	54	-16.34	31.06	6.86	52.86	100	258	Average
4874	44.5	59.44	74	-29.5	31.06	6.86	52.86	100	258	Peak

Remarks:

- Emission Level = Read Level + Antenna Factor + Cable Loss - Preamp Factor  
Margin value = Emission level – Limit value
- 2437 MHz: Fundamental frequency.
- The other emission levels were very low against the limit.



EUT Test Condition		Measurement Detail	
Channel	Channel 11	Frequency Range	1 GHz ~ 25 GHz
Input Power	120 Vac, 60 Hz	Detector Function	Peak (PK) Average (AV)
Environmental Conditions	25 deg. C, 65 % RH	Tested By	Gavin Wu

Antenna Polarity & Test Distance: Horizontal at 3 m										
Frequency (MHz)	Emission Level (dBuV/m)	Read Level (dBuV)	Limit (dBuV/m)	Margin (dB)	Antenna Factor (dB/m)	Cable Loss (dB)	Preamp Factor (dB)	Antenna Height (cm)	Table Angle (Degree)	Remark
2462	102.1	107.98			27.1	4.41	37.39	180	236	Average
2462	105.92	111.8			27.1	4.41	37.39	180	236	Peak
2483.92	40.69	62.56	54	-13.31	27.15	4.94	53.96	180	236	Average
2483.92	53.04	58.78	74	-20.96	27.15	4.43	37.32	180	236	Peak
4924	51.15	66.03	54	-2.85	31.12	6.89	52.89	119	47	Average
4924	53.49	68.37	74	-20.51	31.12	6.89	52.89	119	47	Peak
Antenna Polarity & Test Distance: Vertical at 3 m										
Frequency (MHz)	Emission Level (dBuV/m)	Read Level (dBuV)	Limit (dBuV/m)	Margin (dB)	Antenna Factor (dB/m)	Cable Loss (dB)	Preamp Factor (dB)	Antenna Height (cm)	Table Angle (Degree)	Remark
2462	100.49	106.37			27.1	4.41	37.39	100	74	Average
2462	104.39	110.27			27.1	4.41	37.39	100	74	Peak
2486.56	38.94	60.81	54	-15.06	27.15	4.94	53.96	100	74	Average
2486.56	52.33	58.07	74	-21.67	27.15	4.43	37.32	100	74	Peak
4924	45.94	60.82	54	-8.06	31.12	6.89	52.89	109	258	Average
4924	49.47	64.35	74	-24.53	31.12	6.89	52.89	109	258	Peak

Remarks:

- Emission Level = Read Level + Antenna Factor + Cable Loss - Preamp Factor  
Margin value = Emission level – Limit value
- 2462 MHz: Fundamental frequency.
- The other emission levels were very low against the limit.

802.11g

EUT Test Condition		Measurement Detail	
Channel	Channel 1	Frequency Range	1 GHz ~ 25 GHz
Input Power	120 Vac, 60 Hz	Detector Function	Peak (PK) Average (AV)
Environmental Conditions	25 deg. C, 65 % RH	Tested By	Gavin Wu

Antenna Polarity & Test Distance: Horizontal at 3 m										
Frequency (MHz)	Emission Level (dBuV/m)	Read Level (dBuV)	Limit (dBuV/m)	Margin (dB)	Antenna Factor (dB/m)	Cable Loss (dB)	Preamp Factor (dB)	Antenna Height (cm)	Table Angle (Degree)	Remark
2389.92	47.12	69.25	54	-6.88	26.91	4.85	53.89	200	237	Average
2389.92	68.34	74.59	74	-5.66	26.91	4.36	37.52	200	237	Peak
2412	94.79	100.97			26.96	4.38	37.52	200	237	Average
2412	105.06	111.24			26.96	4.38	37.52	200	237	Peak
4824	34.74	49.83	54	-19.26	30.99	6.81	52.89	100	29	Average
4824	45.76	60.85	74	-28.24	30.99	6.81	52.89	100	29	Peak
Antenna Polarity & Test Distance: Vertical at 3 m										
Frequency (MHz)	Emission Level (dBuV/m)	Read Level (dBuV)	Limit (dBuV/m)	Margin (dB)	Antenna Factor (dB/m)	Cable Loss (dB)	Preamp Factor (dB)	Antenna Height (cm)	Table Angle (Degree)	Remark
2387.22	43.79	65.91	54	-10.21	26.91	4.84	53.87	100	94	Average
2387.22	65.31	71.54	74	-8.69	26.91	4.36	37.5	100	94	Peak
2412	92.1	98.28			26.96	4.38	37.52	100	94	Average
2412	102.59	108.77			26.96	4.38	37.52	100	94	Peak
4824	33.69	48.78	54	-20.31	30.99	6.81	52.89	100	278	Average
4824	44.55	59.64	74	-29.45	30.99	6.81	52.89	100	278	Peak

Remarks:

- Emission Level = Read Level + Antenna Factor + Cable Loss - Preamp Factor  
Margin value = Emission level – Limit value
- 2412 MHz: Fundamental frequency.
- The other emission levels were very low against the limit.

EUT Test Condition		Measurement Detail	
Channel	Channel 6	Frequency Range	1 GHz ~ 25 GHz
Input Power	120 Vac, 60 Hz	Detector Function	Peak (PK) Average (AV)
Environmental Conditions	25 deg. C, 65 % RH	Tested By	Gavin Wu

Antenna Polarity & Test Distance: Horizontal at 3 m										
Frequency (MHz)	Emission Level (dBuV/m)	Read Level (dBuV)	Limit (dBuV/m)	Margin (dB)	Antenna Factor (dB/m)	Cable Loss (dB)	Preamp Factor (dB)	Antenna Height (cm)	Table Angle (Degree)	Remark
2388.75	39.33	61.44	54	-14.67	26.91	4.85	53.87	100	239	Average
2388.75	52.11	58.34	74	-21.89	26.91	4.36	37.5	100	239	Peak
2437	97.01	103.01			27.06	4.4	37.46	100	239	Average
2437	105.92	111.92			27.06	4.4	37.46	100	239	Peak
2487.28	37.55	59.42	54	-16.45	27.15	4.94	53.96	100	239	Average
2487.28	50.17	55.91	74	-23.83	27.15	4.43	37.32	100	239	Peak
4874	33.47	48.41	54	-20.53	31.06	6.86	52.86	100	52	Average
4874	43.45	58.39	74	-30.55	31.06	6.86	52.86	100	52	Peak
Antenna Polarity & Test Distance: Vertical at 3 m										
Frequency (MHz)	Emission Level (dBuV/m)	Read Level (dBuV)	Limit (dBuV/m)	Margin (dB)	Antenna Factor (dB/m)	Cable Loss (dB)	Preamp Factor (dB)	Antenna Height (cm)	Table Angle (Degree)	Remark
2389.02	37.84	59.95	54	-16.16	26.91	4.85	53.87	100	91	Average
2389.02	49.03	55.26	74	-24.97	26.91	4.36	37.5	100	91	Peak
2437	95.41	101.41			27.06	4.4	37.46	100	91	Average
2437	104.61	110.61			27.06	4.4	37.46	100	91	Peak
2486.48	37.47	59.34	54	-16.53	27.15	4.94	53.96	100	91	Average
2486.48	49.66	55.4	74	-24.34	27.15	4.43	37.32	100	91	Peak
4874	33.46	48.4	54	-20.54	31.06	6.86	52.86	100	276	Average
4874	44.7	59.64	74	-29.3	31.06	6.86	52.86	100	276	Peak

Remarks:

- Emission Level = Read Level + Antenna Factor + Cable Loss - Preamp Factor  
Margin value = Emission level – Limit value
- 2437 MHz: Fundamental frequency.
- The other emission levels were very low against the limit.

EUT Test Condition		Measurement Detail	
Channel	Channel 11	Frequency Range	1 GHz ~ 25 GHz
Input Power	120 Vac, 60 Hz	Detector Function	Peak (PK) Average (AV)
Environmental Conditions	25 deg. C, 65 % RH	Tested By	Gavin Wu

Antenna Polarity & Test Distance: Horizontal at 3 m										
Frequency (MHz)	Emission Level (dBuV/m)	Read Level (dBuV)	Limit (dBuV/m)	Margin (dB)	Antenna Factor (dB/m)	Cable Loss (dB)	Preamp Factor (dB)	Antenna Height (cm)	Table Angle (Degree)	Remark
2462	96.9	102.78			27.1	4.41	37.39	200	233	Average
2462	105.99	111.87			27.1	4.41	37.39	200	233	Peak
2483.56	44.69	66.56	54	-9.31	27.15	4.94	53.96	200	233	Average
2483.56	64.2	69.94	74	-9.8	27.15	4.43	37.32	200	233	Peak
4924	33.77	48.65	54	-20.23	31.12	6.89	52.89	100	56	Average
4924	44.51	59.39	74	-29.49	31.12	6.89	52.89	100	56	Peak
Antenna Polarity & Test Distance: Vertical at 3 m										
Frequency (MHz)	Emission Level (dBuV/m)	Read Level (dBuV)	Limit (dBuV/m)	Margin (dB)	Antenna Factor (dB/m)	Cable Loss (dB)	Preamp Factor (dB)	Antenna Height (cm)	Table Angle (Degree)	Remark
2462	94.54	100.42			27.1	4.41	37.39	110	93	Average
2462	103.88	109.76			27.1	4.41	37.39	110	93	Peak
2484.12	44.13	66	54	-9.87	27.15	4.94	53.96	110	93	Average
2484.12	61.94	67.68	74	-12.06	27.15	4.43	37.32	110	93	Peak
4924	32.68	47.56	54	-21.32	31.12	6.89	52.89	100	56	Average
4924	43.92	58.8	74	-30.08	31.12	6.89	52.89	100	56	Peak

Remarks:

- Emission Level = Read Level + Antenna Factor + Cable Loss - Preamp Factor  
Margin value = Emission level – Limit value
- 2462 MHz: Fundamental frequency.
- The other emission levels were very low against the limit.

### 802.11n (HT20)

EUT Test Condition		Measurement Detail	
Channel	Channel 1	Frequency Range	1 GHz ~ 25 GHz
Input Power	120 Vac, 60 Hz	Detector Function	Peak (PK) Average (AV)
Environmental Conditions	25 deg. C, 65 % RH	Tested By	Gavin Wu

Antenna Polarity & Test Distance: Horizontal at 3 m										
Frequency (MHz)	Emission Level (dBuV/m)	Read Level (dBuV)	Limit (dBuV/m)	Margin (dB)	Antenna Factor (dB/m)	Cable Loss (dB)	Preamp Factor (dB)	Antenna Height (cm)	Table Angle (Degree)	Remark
2389.74	52.63	74.74	54	-1.37	26.91	4.85	53.87	223	237	Average
2389.74	72.73	78.96	74	-1.27	26.91	4.36	37.5	223	237	Peak
2412	96.66	102.84			26.96	4.38	37.52	223	237	Average
2412	105.95	112.13			26.96	4.38	37.52	223	237	Peak
4824	37.81	52.9	54	-16.19	30.99	6.81	52.89	100	48	Average
4824	48.24	63.33	74	-25.76	30.99	6.81	52.89	100	48	Peak
Antenna Polarity & Test Distance: Vertical at 3 m										
Frequency (MHz)	Emission Level (dBuV/m)	Read Level (dBuV)	Limit (dBuV/m)	Margin (dB)	Antenna Factor (dB/m)	Cable Loss (dB)	Preamp Factor (dB)	Antenna Height (cm)	Table Angle (Degree)	Remark
2389.11	51.13	73.24	54	-2.87	26.91	4.85	53.87	109	289	Average
2389.11	70.85	77.08	74	-3.15	26.91	4.36	37.5	109	289	Peak
2412	94.36	100.54			26.96	4.38	37.52	109	289	Average
2412	104.11	110.29			26.96	4.38	37.52	109	289	Peak
4824	34.29	49.38	54	-19.71	30.99	6.81	52.89	100	111	Average
4824	43.08	58.17	74	-30.92	30.99	6.81	52.89	100	111	Peak

Remarks:

- Emission Level = Read Level + Antenna Factor + Cable Loss - Preamp Factor  
Margin value = Emission level – Limit value
- 2412 MHz: Fundamental frequency.
- The other emission levels were very low against the limit.

EUT Test Condition		Measurement Detail	
Channel	Channel 6	Frequency Range	1 GHz ~ 25 GHz
Input Power	120 Vac, 60 Hz	Detector Function	Peak (PK) Average (AV)
Environmental Conditions	25 deg. C, 65 % RH	Tested By	Gavin Wu

Antenna Polarity & Test Distance: Horizontal at 3 m										
Frequency (MHz)	Emission Level (dBuV/m)	Read Level (dBuV)	Limit (dBuV/m)	Margin (dB)	Antenna Factor (dB/m)	Cable Loss (dB)	Preamp Factor (dB)	Antenna Height (cm)	Table Angle (Degree)	Remark
2389.47	51.76	57.99	74	-22.24	26.91	4.36	37.5	219	236	Peak
2389.74	39.39	61.5	54	-14.61	26.91	4.85	53.87	219	236	Average
2437	98.19	104.19			27.06	4.4	37.46	219	236	Average
2437	107.98	113.98			27.06	4.4	37.46	219	236	Peak
2486.32	39.69	61.56	54	-14.31	27.15	4.94	53.96	219	236	Average
2486.32	52.39	58.13	74	-21.61	27.15	4.43	37.32	219	236	Peak
4874	37.53	52.47	54	-16.47	31.06	6.86	52.86	100	249	Average
4874	49.98	64.92	74	-24.02	31.06	6.86	52.86	100	249	Peak
Antenna Polarity & Test Distance: Vertical at 3 m										
Frequency (MHz)	Emission Level (dBuV/m)	Read Level (dBuV)	Limit (dBuV/m)	Margin (dB)	Antenna Factor (dB/m)	Cable Loss (dB)	Preamp Factor (dB)	Antenna Height (cm)	Table Angle (Degree)	Remark
2384.16	39.28	61.45	54	-14.72	26.86	4.84	53.87	110	293	Average
2384.16	51.37	57.66	74	-22.63	26.86	4.35	37.5	110	293	Peak
2437	96.63	102.63			27.06	4.4	37.46	110	293	Average
2437	105.77	111.77			27.06	4.4	37.46	110	293	Peak
2483.52	38.9	60.77	54	-15.1	27.15	4.94	53.96	110	293	Average
2483.52	51.43	57.17	74	-22.57	27.15	4.43	37.32	110	293	Peak
4874	35.87	50.81	54	-18.13	31.06	6.86	52.86	100	255	Average
4874	46.28	61.22	74	-27.72	31.06	6.86	52.86	100	255	Peak

Remarks:

- Emission Level = Read Level + Antenna Factor + Cable Loss - Preamp Factor  
Margin value = Emission level – Limit value
- 2437 MHz: Fundamental frequency.
- The other emission levels were very low against the limit.

EUT Test Condition		Measurement Detail	
Channel	Channel 11	Frequency Range	1 GHz ~ 25 GHz
Input Power	120 Vac, 60 Hz	Detector Function	Peak (PK) Average (AV)
Environmental Conditions	25 deg. C, 65 % RH	Tested By	Gavin Wu

Antenna Polarity & Test Distance: Horizontal at 3 m										
Frequency (MHz)	Emission Level (dBuV/m)	Read Level (dBuV)	Limit (dBuV/m)	Margin (dB)	Antenna Factor (dB/m)	Cable Loss (dB)	Preamp Factor (dB)	Antenna Height (cm)	Table Angle (Degree)	Remark
2462	97.66	103.54			27.1	4.41	37.39	200	238	Average
2462	107.04	112.92			27.1	4.41	37.39	200	238	Peak
2483.52	52.98	58.72	54	-1.02	27.15	4.43	37.32	200	238	Average
2483.52	72.93	78.67	74	-1.07	27.15	4.43	37.32	200	238	Peak
4924	38.18	53.06	54	-15.82	31.12	6.89	52.89	100	44	Average
4924	50.06	64.94	74	-23.94	31.12	6.89	52.89	100	44	Peak
Antenna Polarity & Test Distance: Vertical at 3 m										
Frequency (MHz)	Emission Level (dBuV/m)	Read Level (dBuV)	Limit (dBuV/m)	Margin (dB)	Antenna Factor (dB/m)	Cable Loss (dB)	Preamp Factor (dB)	Antenna Height (cm)	Table Angle (Degree)	Remark
2462	95.96	101.84			27.1	4.41	37.39	100	72	Average
2462	105.89	111.77			27.1	4.41	37.39	100	72	Peak
2483.52	51.14	56.88	54	-2.86	27.15	4.43	37.32	100	72	Average
2483.52	71.73	77.47	74	-2.27	27.15	4.43	37.32	100	72	Peak
4924	35.43	50.31	54	-18.57	31.12	6.89	52.89	100	257	Average
4924	46.68	61.56	74	-27.32	31.12	6.89	52.89	100	257	Peak

Remarks:

1. Emission Level = Read Level + Antenna Factor + Cable Loss - Preamp Factor  
Margin value = Emission level – Limit value
2. 2462 MHz: Fundamental frequency.
3. The other emission levels were very low against the limit.

802.11n (HT40)

EUT Test Condition		Measurement Detail	
Channel	Channel 3	Frequency Range	1 GHz ~ 25 GHz
Input Power	120 Vac, 60 Hz	Detector Function	Peak (PK) Average (AV)
Environmental Conditions	25 deg. C, 65 % RH	Tested By	Gavin Wu

Antenna Polarity & Test Distance: Horizontal at 3 m										
Frequency (MHz)	Emission Level (dBuV/m)	Read Level (dBuV)	Limit (dBuV/m)	Margin (dB)	Antenna Factor (dB/m)	Cable Loss (dB)	Preamp Factor (dB)	Antenna Height (cm)	Table Angle (Degree)	Remark
2386.59	53	75.12	54	-1	26.91	4.84	53.87	200	251	Average
2386.59	71.18	77.41	74	-2.82	26.91	4.36	37.5	200	251	Peak
2422	94.17	100.23			27.01	4.39	37.46	200	251	Average
2422	103.45	109.51			27.01	4.39	37.46	200	251	Peak
2499.08	38.06	59.89	54	-15.94	27.2	4.95	53.98	200	251	Average
2499.08	50.28	55.89	74	-23.72	27.2	4.44	37.25	200	251	Peak
4844	36.71	51.75	54	-17.29	31.01	6.83	52.88	100	48	Average
4844	46.45	61.49	74	-27.55	31.01	6.83	52.88	100	48	Peak
Antenna Polarity & Test Distance: Vertical at 3 m										
Frequency (MHz)	Emission Level (dBuV/m)	Read Level (dBuV)	Limit (dBuV/m)	Margin (dB)	Antenna Factor (dB/m)	Cable Loss (dB)	Preamp Factor (dB)	Antenna Height (cm)	Table Angle (Degree)	Remark
2389.65	50.81	72.92	54	-3.19	26.91	4.85	53.87	109	270	Average
2389.65	68.24	74.47	74	-5.76	26.91	4.36	37.5	109	270	Peak
2422	92.58	98.64			27.01	4.39	37.46	109	270	Average
2422	101.72	107.78			27.01	4.39	37.46	109	270	Peak
2484.84	36.85	58.72	54	-17.15	27.15	4.94	53.96	109	270	Average
2484.84	49.04	54.78	74	-24.96	27.15	4.43	37.32	109	270	Peak
4844	35.37	50.41	54	-18.63	31.01	6.83	52.88	100	255	Average
4844	45.83	60.87	74	-28.17	31.01	6.83	52.88	100	255	Peak

Remarks:

- Emission Level = Read Level + Antenna Factor + Cable Loss - Preamp Factor  
Margin value = Emission level – Limit value
- 2422 MHz: Fundamental frequency.
- The other emission levels were very low against the limit.



EUT Test Condition		Measurement Detail	
Channel	Channel 6	Frequency Range	1 GHz ~ 25 GHz
Input Power	120 Vac, 60 Hz	Detector Function	Peak (PK) Average (AV)
Environmental Conditions	25 deg. C, 65 % RH	Tested By	Gavin Wu

Antenna Polarity & Test Distance: Horizontal at 3 m										
Frequency (MHz)	Emission Level (dBuV/m)	Read Level (dBuV)	Limit (dBuV/m)	Margin (dB)	Antenna Factor (dB/m)	Cable Loss (dB)	Preamp Factor (dB)	Antenna Height (cm)	Table Angle (Degree)	Remark
2389.38	53	75.11	54	-1	26.91	4.85	53.87	200	248	Average
2389.38	70.89	77.12	74	-3.11	26.91	4.36	37.5	200	248	Peak
2437	95.4	101.4			27.06	4.4	37.46	200	248	Average
2437	104.56	110.56			27.06	4.4	37.46	200	248	Peak
2484.04	46.66	68.53	54	-7.34	27.15	4.94	53.96	200	248	Average
2484.04	65.65	71.39	74	-8.35	27.15	4.43	37.32	200	248	Peak
4874	37.95	52.89	54	-16.05	31.06	6.86	52.86	100	225	Average
4874	46.64	61.58	74	-27.36	31.06	6.86	52.86	100	225	Peak
Antenna Polarity & Test Distance: Vertical at 3 m										
Frequency (MHz)	Emission Level (dBuV/m)	Read Level (dBuV)	Limit (dBuV/m)	Margin (dB)	Antenna Factor (dB/m)	Cable Loss (dB)	Preamp Factor (dB)	Antenna Height (cm)	Table Angle (Degree)	Remark
2389.83	52.1	74.23	54	-1.9	26.91	4.85	53.89	110	269	Average
2389.83	68.9	75.15	74	-5.1	26.91	4.36	37.52	110	269	Peak
2437	93.22	99.22			27.06	4.4	37.46	110	269	Average
2437	102.3	108.3			27.06	4.4	37.46	110	269	Peak
2485.28	48	69.87	54	-6	27.15	4.94	53.96	110	269	Average
2485.28	68.32	74.06	74	-5.68	27.15	4.43	37.32	110	269	Peak
4874	36.04	50.98	54	-17.96	31.06	6.86	52.86	100	83	Average
4874	45.93	60.87	74	-28.07	31.06	6.86	52.86	100	83	Peak

Remarks:

- Emission Level = Read Level + Antenna Factor + Cable Loss - Preamp Factor  
Margin value = Emission level – Limit value
- 2437 MHz: Fundamental frequency.
- The other emission levels were very low against the limit.

EUT Test Condition		Measurement Detail	
Channel	Channel 9	Frequency Range	1 GHz ~ 25 GHz
Input Power	120 Vac, 60 Hz	Detector Function	Peak (PK) Average (AV)
Environmental Conditions	25 deg. C, 65 % RH	Tested By	Gavin Wu

Antenna Polarity & Test Distance: Horizontal at 3 m										
Frequency (MHz)	Emission Level (dBuV/m)	Read Level (dBuV)	Limit (dBuV/m)	Margin (dB)	Antenna Factor (dB/m)	Cable Loss (dB)	Preamp Factor (dB)	Antenna Height (cm)	Table Angle (Degree)	Remark
2389.47	40.57	46.8	54	-13.43	26.91	4.36	37.5	200	246	Average
2389.47	55.99	62.22	74	-18.01	26.91	4.36	37.5	200	246	Peak
2452	94.44	100.36			27.06	4.41	37.39	200	246	Average
2452	103.51	109.43			27.06	4.41	37.39	200	246	Peak
2484.44	53.47	75.34	54	-0.53	27.15	4.94	53.96	200	246	Average
2484.44	72.11	77.85	74	-1.89	27.15	4.43	37.32	200	246	Peak
4904	36.61	51.48	54	-17.39	31.1	6.88	52.85	100	126	Average
4904	46.38	61.25	74	-27.62	31.1	6.88	52.85	100	126	Peak
Antenna Polarity & Test Distance: Vertical at 3 m										
Frequency (MHz)	Emission Level (dBuV/m)	Read Level (dBuV)	Limit (dBuV/m)	Margin (dB)	Antenna Factor (dB/m)	Cable Loss (dB)	Preamp Factor (dB)	Antenna Height (cm)	Table Angle (Degree)	Remark
2387.94	39.89	62	54	-14.11	26.91	4.85	53.87	110	268	Average
2387.94	54.2	60.43	74	-19.8	26.91	4.36	37.5	110	268	Peak
2452	92.42	98.34			27.06	4.41	37.39	110	268	Average
2452	101.04	106.96			27.06	4.41	37.39	110	268	Peak
2486.08	53.01	74.88	54	-0.99	27.15	4.94	53.96	110	268	Average
2486.08	71.14	76.88	74	-2.86	27.15	4.43	37.32	110	268	Peak
4904	35.52	50.39	54	-18.48	31.1	6.88	52.85	100	51	Average
4904	45.16	60.03	74	-28.84	31.1	6.88	52.85	100	51	Peak

Remarks:

- Emission Level = Read Level + Antenna Factor + Cable Loss - Preamp Factor  
Margin value = Emission level – Limit value
- 2452 MHz: Fundamental frequency.
- The other emission levels were very low against the limit.

**Mode B**  
**802.11b**

EUT Test Condition		Measurement Detail	
Channel	Channel 1	Frequency Range	1 GHz ~ 25 GHz
Input Power	120 Vac, 60 Hz	Detector Function	Peak (PK) Average (AV)
Environmental Conditions	25 deg. C, 65 % RH	Tested By	Thomas Wei

Antenna Polarity & Test Distance: Horizontal at 3 m										
Frequency (MHz)	Emission Level (dBuV/m)	Read Level (dBuV)	Limit (dBuV/m)	Margin (dB)	Antenna Factor (dB/m)	Cable Loss (dB)	Preamp Factor (dB)	Antenna Height (cm)	Table Angle (Degree)	Remark
2387	45.76	51.74	54	-8.24	27.16	4.36	37.5	175	170	Average
2387	57.85	63.83	74	-16.15	27.16	4.36	37.5	175	170	Peak
2412	108.65	114.56			27.23	4.38	37.52	175	170	Average
2412	111.62	117.53			27.23	4.38	37.52	175	170	Peak
4824	53.22	68.13	54	-0.78	31.17	6.81	52.89	185	265	Average
4824	55.4	70.31	74	-18.6	31.17	6.81	52.89	185	265	Peak

Antenna Polarity & Test Distance: Vertical at 3 m										
Frequency (MHz)	Emission Level (dBuV/m)	Read Level (dBuV)	Limit (dBuV/m)	Margin (dB)	Antenna Factor (dB/m)	Cable Loss (dB)	Preamp Factor (dB)	Antenna Height (cm)	Table Angle (Degree)	Remark
2386.86	37.22	43.2	54	-16.78	27.16	4.36	37.5	100	261	Average
2386.86	49.8	55.78	74	-24.2	27.16	4.36	37.5	100	261	Peak
2412	97.02	102.93			27.23	4.38	37.52	100	261	Average
2412	100.96	106.87			27.23	4.38	37.52	100	261	Peak
4824	52.42	67.33	54	-1.58	31.17	6.81	52.89	124	289	Average
4824	53.6	68.51	74	-20.4	31.17	6.81	52.89	124	289	Peak

Remarks:

- Emission Level = Read Level + Antenna Factor + Cable Loss - Preamp Factor  
Margin value = Emission level – Limit value
- 2412 MHz: Fundamental frequency.
- The other emission levels were very low against the limit.

EUT Test Condition		Measurement Detail	
Channel	Channel 6	Frequency Range	1 GHz ~ 25 GHz
Input Power	120 Vac, 60 Hz	Detector Function	Peak (PK) Average (AV)
Environmental Conditions	25 deg. C, 65 % RH	Tested By	Thomas Wei

Antenna Polarity & Test Distance: Horizontal at 3 m										
Frequency (MHz)	Emission Level (dBuV/m)	Read Level (dBuV)	Limit (dBuV/m)	Margin (dB)	Antenna Factor (dB/m)	Cable Loss (dB)	Preamp Factor (dB)	Antenna Height (cm)	Table Angle (Degree)	Remark
2389.94	41.85	47.85	54	-12.15	27.16	4.36	37.52	154	170	Average
2389.94	54.03	60.03	74	-19.97	27.16	4.36	37.52	154	170	Peak
2437	107.24	112.92			27.38	4.4	37.46	154	170	Average
2437	111.12	116.8			27.38	4.4	37.46	154	170	Peak
2483.52	43.49	48.85	54	-10.51	27.53	4.43	37.32	154	170	Average
2483.52	56.83	62.19	74	-17.17	27.53	4.43	37.32	154	170	Peak
4874	52.56	68.02	54	-1.44	31.25	6.15	52.86	142	202	Average
4874	53.83	69.29	74	-20.17	31.25	6.15	52.86	142	202	Peak
Antenna Polarity & Test Distance: Vertical at 3 m										
Frequency (MHz)	Emission Level (dBuV/m)	Read Level (dBuV)	Limit (dBuV/m)	Margin (dB)	Antenna Factor (dB/m)	Cable Loss (dB)	Preamp Factor (dB)	Antenna Height (cm)	Table Angle (Degree)	Remark
2382.1	35.83	41.9	54	-18.17	27.08	4.35	37.5	100	262	Average
2382.1	48.54	54.61	74	-25.46	27.08	4.35	37.5	100	262	Peak
2437	97.52	103.2			27.38	4.4	37.46	100	262	Average
2437	101.44	107.12			27.38	4.4	37.46	100	262	Peak
2483.52	37.24	42.6	54	-16.76	27.53	4.43	37.32	100	262	Average
2483.52	49.92	55.28	74	-24.08	27.53	4.43	37.32	100	262	Peak
4874	50.7	66.16	54	-3.3	31.25	6.15	52.86	131	262	Average
4874	52.56	68.02	74	-21.44	31.25	6.15	52.86	131	262	Peak

Remarks:

- Emission Level = Read Level + Antenna Factor + Cable Loss - Preamp Factor  
Margin value = Emission level – Limit value
- 2437 MHz: Fundamental frequency.
- The other emission levels were very low against the limit.

EUT Test Condition		Measurement Detail	
Channel	Channel 11	Frequency Range	1 GHz ~ 25 GHz
Input Power	120 Vac, 60 Hz	Detector Function	Peak (PK) Average (AV)
Environmental Conditions	25 deg. C, 65 % RH	Tested By	Thomas Wei

Antenna Polarity & Test Distance: Horizontal at 3 m										
Frequency (MHz)	Emission Level (dBuV/m)	Read Level (dBuV)	Limit (dBuV/m)	Margin (dB)	Antenna Factor (dB/m)	Cable Loss (dB)	Preamp Factor (dB)	Antenna Height (cm)	Table Angle (Degree)	Remark
2462	108.62	114.14			27.46	4.41	37.39	171	170	Average
2462	112.53	118.05			27.46	4.41	37.39	171	170	Peak
2483.88	46.5	51.86	54	-7.5	27.53	4.43	37.32	171	170	Average
2483.88	59.26	64.62	74	-14.74	27.53	4.43	37.32	171	170	Peak
4924	53.9	68.56	54	-0.1	31.34	6.89	52.89	149	198	Average
4924	55.24	69.9	74	-18.76	31.34	6.89	52.89	149	198	Peak
Antenna Polarity & Test Distance: Vertical at 3 m										
Frequency (MHz)	Emission Level (dBuV/m)	Read Level (dBuV)	Limit (dBuV/m)	Margin (dB)	Antenna Factor (dB/m)	Cable Loss (dB)	Preamp Factor (dB)	Antenna Height (cm)	Table Angle (Degree)	Remark
2462	98.9	104.42			27.46	4.41	37.39	100	261	Average
2462	102.85	108.37			27.46	4.41	37.39	100	261	Peak
2483.8	39.02	44.38	54	-14.98	27.53	4.43	37.32	100	261	Average
2483.8	51.98	57.34	74	-22.02	27.53	4.43	37.32	100	261	Peak
4924	51.7	66.36	54	-2.3	31.34	6.89	52.89	129	262	Average
4924	52.91	67.57	74	-21.09	31.34	6.89	52.89	129	262	Peak

Remarks:

1. Emission Level = Read Level + Antenna Factor + Cable Loss - Preamp Factor  
Margin value = Emission level – Limit value
2. 2462 MHz: Fundamental frequency.
3. The other emission levels were very low against the limit.

802.11g

EUT Test Condition		Measurement Detail	
Channel	Channel 1	Frequency Range	1 GHz ~ 25 GHz
Input Power	120 Vac, 60 Hz	Detector Function	Peak (PK) Average (AV)
Environmental Conditions	25 deg. C, 65 % RH	Tested By	Thomas Wei

Antenna Polarity & Test Distance: Horizontal at 3 m										
Frequency (MHz)	Emission Level (dBuV/m)	Read Level (dBuV)	Limit (dBuV/m)	Margin (dB)	Antenna Factor (dB/m)	Cable Loss (dB)	Preamp Factor (dB)	Antenna Height (cm)	Table Angle (Degree)	Remark
2389.94	50.2	56.2	54	-3.8	27.16	4.36	37.52	156	174	Average
2389.94	69.48	75.48	74	-4.52	27.16	4.36	37.52	156	174	Peak
2412	102.29	108.2			27.23	4.38	37.52	156	174	Average
2412	111.95	117.86			27.23	4.38	37.52	156	174	Peak
4824	40.21	55.12	54	-13.79	31.17	6.81	52.89	145	201	Average
4824	51.16	66.07	74	-22.84	31.17	6.81	52.89	145	201	Peak
Antenna Polarity & Test Distance: Vertical at 3 m										
Frequency (MHz)	Emission Level (dBuV/m)	Read Level (dBuV)	Limit (dBuV/m)	Margin (dB)	Antenna Factor (dB/m)	Cable Loss (dB)	Preamp Factor (dB)	Antenna Height (cm)	Table Angle (Degree)	Remark
2389.94	41.06	47.06	54	-12.94	27.16	4.36	37.52	100	263	Average
2389.94	58.91	64.91	74	-15.09	27.16	4.36	37.52	100	263	Peak
2412	92.76	98.67			27.23	4.38	37.52	100	263	Average
2412	102.95	108.86			27.23	4.38	37.52	100	263	Peak
4824	38.52	53.43	54	-15.48	31.17	6.81	52.89	133	262	Average
4824	48.89	63.8	74	-25.11	31.17	6.81	52.89	133	262	Peak

Remarks:

- Emission Level = Read Level + Antenna Factor + Cable Loss - Preamp Factor  
Margin value = Emission level – Limit value
- 2412 MHz: Fundamental frequency.
- The other emission levels were very low against the limit.

EUT Test Condition		Measurement Detail	
Channel	Channel 6	Frequency Range	1 GHz ~ 25 GHz
Input Power	120 Vac, 60 Hz	Detector Function	Peak (PK) Average (AV)
Environmental Conditions	25 deg. C, 65 % RH	Tested By	Thomas Wei

Antenna Polarity & Test Distance: Horizontal at 3 m										
Frequency (MHz)	Emission Level (dBuV/m)	Read Level (dBuV)	Limit (dBuV/m)	Margin (dB)	Antenna Factor (dB/m)	Cable Loss (dB)	Preamp Factor (dB)	Antenna Height (cm)	Table Angle (Degree)	Remark
2389.94	42.68	48.68	54	-11.32	27.16	4.36	37.52	154	171	Average
2389.94	55.49	61.49	74	-18.51	27.16	4.36	37.52	154	171	Peak
2437	102.99	108.67			27.38	4.4	37.46	154	171	Average
2437	113.13	118.81			27.38	4.4	37.46	154	171	Peak
2483.56	44.46	49.82	54	-9.54	27.53	4.43	37.32	154	171	Average
2483.56	57.97	63.33	74	-16.03	27.53	4.43	37.32	154	171	Peak
4874	40.44	55.19	54	-13.56	31.25	6.86	52.86	147	205	Average
4874	51.35	66.1	74	-22.65	31.25	6.86	52.86	147	205	Peak
Antenna Polarity & Test Distance: Vertical at 3 m										
Frequency (MHz)	Emission Level (dBuV/m)	Read Level (dBuV)	Limit (dBuV/m)	Margin (dB)	Antenna Factor (dB/m)	Cable Loss (dB)	Preamp Factor (dB)	Antenna Height (cm)	Table Angle (Degree)	Remark
2389.66	36.18	42.16	54	-17.82	27.16	4.36	37.5	100	262	Average
2389.66	48.96	54.94	74	-25.04	27.16	4.36	37.5	100	262	Peak
2437	92.99	98.67			27.38	4.4	37.46	100	262	Average
2437	103.14	108.82			27.38	4.4	37.46	100	262	Peak
2483.52	37.92	43.28	54	-16.08	27.53	4.43	37.32	100	262	Average
2483.52	51.35	56.71	74	-22.65	27.53	4.43	37.32	100	262	Peak
4874	38.79	53.54	54	-15.21	31.25	6.86	52.86	128	261	Average
4874	49.03	63.78	74	-24.97	31.25	6.86	52.86	128	261	Peak

Remarks:

- Emission Level = Read Level + Antenna Factor + Cable Loss - Preamp Factor  
Margin value = Emission level – Limit value
- 2437 MHz: Fundamental frequency.
- The other emission levels were very low against the limit.

EUT Test Condition		Measurement Detail	
Channel	Channel 11	Frequency Range	1 GHz ~ 25 GHz
Input Power	120 Vac, 60 Hz	Detector Function	Peak (PK) Average (AV)
Environmental Conditions	25 deg. C, 65 % RH	Tested By	Thomas Wei

Antenna Polarity & Test Distance: Horizontal at 3 m										
Frequency (MHz)	Emission Level (dBuV/m)	Read Level (dBuV)	Limit (dBuV/m)	Margin (dB)	Antenna Factor (dB/m)	Cable Loss (dB)	Preamp Factor (dB)	Antenna Height (cm)	Table Angle (Degree)	Remark
2462	101.16	106.68			27.46	4.41	37.39	165	166	Average
2462	111.12	116.64			27.46	4.41	37.39	165	166	Peak
2483.52	53.09	58.45	54	-0.91	27.53	4.43	37.32	165	166	Average
2483.52	73.59	78.95	74	-0.41	27.53	4.43	37.32	165	166	Peak
4924	38.85	53.51	54	-15.15	31.34	6.89	52.89	144	207	Average
4924	49.74	64.4	74	-24.26	31.34	6.89	52.89	144	207	Peak
Antenna Polarity & Test Distance: Vertical at 3 m										
Frequency (MHz)	Emission Level (dBuV/m)	Read Level (dBuV)	Limit (dBuV/m)	Margin (dB)	Antenna Factor (dB/m)	Cable Loss (dB)	Preamp Factor (dB)	Antenna Height (cm)	Table Angle (Degree)	Remark
2462	92.82	98.34			27.46	4.41	37.39	100	264	Average
2462	103.06	108.58			27.46	4.41	37.39	100	264	Peak
2483.52	44.22	49.58	54	-9.78	27.53	4.43	37.32	100	264	Average
2483.52	64.63	69.99	74	-9.37	27.53	4.43	37.32	100	264	Peak
4924	37.37	52.03	54	-16.63	31.34	6.89	52.89	136	265	Average
4924	46.78	61.44	74	-27.22	31.34	6.89	52.89	136	265	Peak

Remarks:

1. Emission Level = Read Level + Antenna Factor + Cable Loss - Preamp Factor  
Margin value = Emission level – Limit value
2. 2462 MHz: Fundamental frequency.
3. The other emission levels were very low against the limit.



802.11n (HT20)

EUT Test Condition		Measurement Detail	
Channel	Channel 1	Frequency Range	1 GHz ~ 25 GHz
Input Power	120 Vac, 60 Hz	Detector Function	Peak (PK) Average (AV)
Environmental Conditions	25 deg. C, 65 % RH	Tested By	Thomas Wei

Antenna Polarity & Test Distance: Horizontal at 3 m										
Frequency (MHz)	Emission Level (dBuV/m)	Read Level (dBuV)	Limit (dBuV/m)	Margin (dB)	Antenna Factor (dB/m)	Cable Loss (dB)	Preamp Factor (dB)	Antenna Height (cm)	Table Angle (Degree)	Remark
2389.94	51.05	57.05	54	-2.95	27.16	4.36	37.52	157	170	Average
2389.94	69.93	75.93	74	-4.07	27.16	4.36	37.52	157	170	Peak
2412	101.85	107.76			27.23	4.38	37.52	157	170	Average
2412	111.54	117.45			27.23	4.38	37.52	157	170	Peak
4824	38.5	54.12	54	-15.5	31.17	6.1	52.89	144	201	Average
4824	49.94	65.56	74	-24.06	31.17	6.1	52.89	144	201	Peak
Antenna Polarity & Test Distance: Vertical at 3 m										
Frequency (MHz)	Emission Level (dBuV/m)	Read Level (dBuV)	Limit (dBuV/m)	Margin (dB)	Antenna Factor (dB/m)	Cable Loss (dB)	Preamp Factor (dB)	Antenna Height (cm)	Table Angle (Degree)	Remark
2389.94	41.99	47.99	54	-12.01	27.16	4.36	37.52	100	260	Average
2389.94	60.35	66.35	74	-13.65	27.16	4.36	37.52	100	260	Peak
2412	92.28	98.19			27.23	4.38	37.52	100	260	Average
2412	102.69	108.6			27.23	4.38	37.52	100	260	Peak
4824	38.43	53.34	54	-15.57	31.17	6.81	52.89	133	289	Average
4824	49.77	64.68	74	-24.23	31.17	6.81	52.89	133	289	Peak

Remarks:

- Emission Level = Read Level + Antenna Factor + Cable Loss - Preamp Factor  
Margin value = Emission level – Limit value
- 2412 MHz: Fundamental frequency.
- The other emission levels were very low against the limit.

EUT Test Condition		Measurement Detail	
Channel	Channel 6	Frequency Range	1 GHz ~ 25 GHz
Input Power	120 Vac, 60 Hz	Detector Function	Peak (PK) Average (AV)
Environmental Conditions	25 deg. C, 65 % RH	Tested By	Thomas Wei

Antenna Polarity & Test Distance: Horizontal at 3 m										
Frequency (MHz)	Emission Level (dBuV/m)	Read Level (dBuV)	Limit (dBuV/m)	Margin (dB)	Antenna Factor (dB/m)	Cable Loss (dB)	Preamp Factor (dB)	Antenna Height (cm)	Table Angle (Degree)	Remark
2389.94	43.09	49.09	54	-10.91	27.16	4.36	37.52	154	169	Average
2389.94	55.92	61.92	74	-18.08	27.16	4.36	37.52	154	169	Peak
2437	101.98	107.66			27.38	4.4	37.46	154	169	Average
2437	111.7	117.38			27.38	4.4	37.46	154	169	Peak
2484.4	44.59	49.95	54	-9.41	27.53	4.43	37.32	154	169	Average
2484.4	58.21	63.57	74	-15.79	27.53	4.43	37.32	154	169	Peak
4874	38.74	53.49	54	-15.26	31.25	6.86	52.86	146	203	Average
4874	50.11	64.86	74	-23.89	31.25	6.86	52.86	146	203	Peak
Antenna Polarity & Test Distance: Vertical at 3 m										
Frequency (MHz)	Emission Level (dBuV/m)	Read Level (dBuV)	Limit (dBuV/m)	Margin (dB)	Antenna Factor (dB/m)	Cable Loss (dB)	Preamp Factor (dB)	Antenna Height (cm)	Table Angle (Degree)	Remark
2389.94	37.74	43.74	54	-16.26	27.16	4.36	37.52	100	262	Average
2389.94	50.34	56.34	74	-23.66	27.16	4.36	37.52	100	262	Peak
2437	92.06	97.74			27.38	4.4	37.46	100	262	Average
2437	102.28	107.96			27.38	4.4	37.46	100	262	Peak
2483.52	38.95	44.31	54	-15.05	27.53	4.43	37.32	100	262	Average
2483.52	52.09	57.45	74	-21.91	27.53	4.43	37.32	100	262	Peak
4874	38.08	52.83	54	-15.92	31.25	6.86	52.86	137	275	Average
4874	49.38	64.13	74	-24.62	31.25	6.86	52.86	137	275	Peak

Remarks:

- Emission Level = Read Level + Antenna Factor + Cable Loss - Preamp Factor  
Margin value = Emission level – Limit value
- 2437 MHz: Fundamental frequency.
- The other emission levels were very low against the limit.

EUT Test Condition		Measurement Detail	
Channel	Channel 11	Frequency Range	1 GHz ~ 25 GHz
Input Power	120 Vac, 60 Hz	Detector Function	Peak (PK) Average (AV)
Environmental Conditions	25 deg. C, 65 % RH	Tested By	Thomas Wei

Antenna Polarity & Test Distance: Horizontal at 3 m										
Frequency (MHz)	Emission Level (dBuV/m)	Read Level (dBuV)	Limit (dBuV/m)	Margin (dB)	Antenna Factor (dB/m)	Cable Loss (dB)	Preamp Factor (dB)	Antenna Height (cm)	Table Angle (Degree)	Remark
2462	99.47	104.99			27.46	4.41	37.39	194	161	Average
2462	109.5	115.02			27.46	4.41	37.39	194	161	Peak
2483.5	53.29	58.65	54	-0.71	27.53	4.43	37.32	194	161	Average
2483.5	73.85	79.21	74	-0.15	27.53	4.43	37.32	194	161	Peak
4924	37.41	52.07	54	-16.59	31.34	6.89	52.89	156	211	Average
4924	48.72	63.38	74	-25.28	31.34	6.89	52.89	156	211	Peak
Antenna Polarity & Test Distance: Vertical at 3 m										
Frequency (MHz)	Emission Level (dBuV/m)	Read Level (dBuV)	Limit (dBuV/m)	Margin (dB)	Antenna Factor (dB/m)	Cable Loss (dB)	Preamp Factor (dB)	Antenna Height (cm)	Table Angle (Degree)	Remark
2462	91.89	97.41			27.46	4.41	37.39	100	263	Average
2462	102.14	107.66			27.46	4.41	37.39	100	263	Peak
2483.52	44.29	49.65	54	-9.71	27.53	4.43	37.32	100	263	Average
2483.88	66.33	71.69	74	-7.67	27.53	4.43	37.32	100	263	Peak
4924	36.96	51.62	54	-17.04	31.34	6.89	52.89	146	251	Average
4924	47.86	62.52	74	-26.14	31.34	6.89	52.89	146	251	Peak

Remarks:

1. Emission Level = Read Level + Antenna Factor + Cable Loss - Preamp Factor  
Margin value = Emission level – Limit value
2. 2462 MHz: Fundamental frequency.
3. The other emission levels were very low against the limit.

### 802.11n (HT40)

EUT Test Condition		Measurement Detail	
Channel	Channel 3	Frequency Range	1 GHz ~ 25 GHz
Input Power	120 Vac, 60 Hz	Detector Function	Peak (PK) Average (AV)
Environmental Conditions	25 deg. C, 65 % RH	Tested By	Thomas Wei

Antenna Polarity & Test Distance: Horizontal at 3 m										
Frequency (MHz)	Emission Level (dBuV/m)	Read Level (dBuV)	Limit (dBuV/m)	Margin (dB)	Antenna Factor (dB/m)	Cable Loss (dB)	Preamp Factor (dB)	Antenna Height (cm)	Table Angle (Degree)	Remark
2389.94	48.86	54.86	54	-5.14	27.16	4.36	37.52	158	170	Average
2389.94	65.54	71.54	74	-8.46	27.16	4.36	37.52	158	170	Peak
2422	95.09	100.85			27.31	4.39	37.46	158	170	Average
2422	105.34	111.1			27.31	4.39	37.46	158	170	Peak
2483.96	40.37	45.73	54	-13.63	27.53	4.43	37.32	158	170	Average
2483.96	54.38	59.74	74	-19.62	27.53	4.43	37.32	158	170	Peak
4844	35.94	50.79	54	-18.06	31.2	6.83	52.88	158	224	Average
4844	46	60.85	74	-28	31.2	6.83	52.88	158	224	Peak
Antenna Polarity & Test Distance: Vertical at 3 m										
Frequency (MHz)	Emission Level (dBuV/m)	Read Level (dBuV)	Limit (dBuV/m)	Margin (dB)	Antenna Factor (dB/m)	Cable Loss (dB)	Preamp Factor (dB)	Antenna Height (cm)	Table Angle (Degree)	Remark
2389.94	40.14	46.14	54	-13.86	27.16	4.36	37.52	100	261	Average
2389.94	57.14	63.14	74	-16.86	27.16	4.36	37.52	100	261	Peak
2422	86.76	92.52			27.31	4.39	37.46	100	261	Average
2422	96.95	102.71			27.31	4.39	37.46	100	261	Peak
2484.12	36.03	41.39	54	-17.97	27.53	4.43	37.32	100	261	Average
2484.12	49.93	55.29	74	-24.07	27.53	4.43	37.32	100	261	Peak
4844	35.44	50.29	54	-18.56	31.2	6.83	52.88	131	254	Average
4844	45.71	60.56	74	-28.29	31.2	6.83	52.88	131	254	Peak

Remarks:

- Emission Level = Read Level + Antenna Factor + Cable Loss - Preamp Factor  
Margin value = Emission level – Limit value
- 2422 MHz: Fundamental frequency.
- The other emission levels were very low against the limit.

EUT Test Condition		Measurement Detail	
Channel	Channel 6	Frequency Range	1 GHz ~ 25 GHz
Input Power	120 Vac, 60 Hz	Detector Function	Peak (PK) Average (AV)
Environmental Conditions	25 deg. C, 65 % RH	Tested By	Thomas Wei

Antenna Polarity & Test Distance: Horizontal at 3 m										
Frequency (MHz)	Emission Level (dBuV/m)	Read Level (dBuV)	Limit (dBuV/m)	Margin (dB)	Antenna Factor (dB/m)	Cable Loss (dB)	Preamp Factor (dB)	Antenna Height (cm)	Table Angle (Degree)	Remark
2389.94	42.34	48.34	54	-11.66	27.16	4.36	37.52	153	169	Average
2389.94	56.95	62.95	74	-17.05	27.16	4.36	37.52	153	169	Peak
2437	97.04	102.72			27.38	4.4	37.46	153	169	Average
2437	107.47	113.15			27.38	4.4	37.46	153	169	Peak
2483.52	44.95	50.31	54	-9.05	27.53	4.43	37.32	153	169	Average
2483.52	62.28	67.64	74	-11.72	27.53	4.43	37.32	153	169	Peak
4874	38.01	52.76	54	-15.99	31.25	6.86	52.86	137	232	Average
4874	49.3	64.05	74	-24.7	31.25	6.86	52.86	137	232	Peak
Antenna Polarity & Test Distance: Vertical at 3 m										
Frequency (MHz)	Emission Level (dBuV/m)	Read Level (dBuV)	Limit (dBuV/m)	Margin (dB)	Antenna Factor (dB/m)	Cable Loss (dB)	Preamp Factor (dB)	Antenna Height (cm)	Table Angle (Degree)	Remark
2389.94	36.18	42.18	54	-17.82	27.16	4.36	37.52	100	262	Average
2389.94	48.8	54.8	74	-25.2	27.16	4.36	37.52	100	262	Peak
2437	87.49	93.17			27.38	4.4	37.46	100	262	Average
2437	97.73	103.41			27.38	4.4	37.46	100	262	Peak
2483.52	38.21	43.57	54	-15.79	27.53	4.43	37.32	100	262	Average
2483.52	52.19	57.55	74	-21.81	27.53	4.43	37.32	100	262	Peak
4874	37.62	52.37	54	-16.38	31.25	6.86	52.86	155	251	Average
4874	48.09	62.84	74	-25.91	31.25	6.86	52.86	155	251	Peak

Remarks:

- Emission Level = Read Level + Antenna Factor + Cable Loss - Preamp Factor  
Margin value = Emission level – Limit value
- 2437 MHz: Fundamental frequency.
- The other emission levels were very low against the limit.

EUT Test Condition		Measurement Detail	
Channel	Channel 9	Frequency Range	1 GHz ~ 25 GHz
Input Power	120 Vac, 60 Hz	Detector Function	Peak (PK) Average (AV)
Environmental Conditions	25 deg. C, 65 % RH	Tested By	Thomas Wei

Antenna Polarity & Test Distance: Horizontal at 3 m										
Frequency (MHz)	Emission Level (dBuV/m)	Read Level (dBuV)	Limit (dBuV/m)	Margin (dB)	Antenna Factor (dB/m)	Cable Loss (dB)	Preamp Factor (dB)	Antenna Height (cm)	Table Angle (Degree)	Remark
2389.66	37.25	43.25	54	-16.75	27.16	4.36	37.52	197	167	Average
2389.66	49.19	55.19	74	-24.81	27.16	4.36	37.52	197	167	Peak
2452	96.31	101.91			27.38	4.41	37.39	197	167	Average
2452	106.01	111.61			27.38	4.41	37.39	197	167	Peak
2486.16	51.82	57.18	54	-2.18	27.53	4.43	37.32	197	167	Average
2486.16	69.92	75.28	74	-4.08	27.53	4.43	37.32	197	167	Peak
4904	36.68	51.34	54	-17.32	31.31	6.88	52.85	146	238	Average
4904	46.37	61.03	74	-27.63	31.31	6.88	52.85	146	238	Peak
Antenna Polarity & Test Distance: Vertical at 3 m										
Frequency (MHz)	Emission Level (dBuV/m)	Read Level (dBuV)	Limit (dBuV/m)	Margin (dB)	Antenna Factor (dB/m)	Cable Loss (dB)	Preamp Factor (dB)	Antenna Height (cm)	Table Angle (Degree)	Remark
2389.52	34.8	40.78	54	-19.2	27.16	4.36	37.5	100	264	Average
2389.52	48.06	54.04	74	-25.94	27.16	4.36	37.5	100	264	Peak
2452	87.5	93.1			27.38	4.41	37.39	100	264	Average
2452	97.42	103.02			27.38	4.41	37.39	100	264	Peak
2483.52	44.14	49.5	54	-9.86	27.53	4.43	37.32	100	264	Average
2483.52	63.99	69.35	74	-10.01	27.53	4.43	37.32	100	264	Peak
4904	36.03	50.69	54	-17.97	31.31	6.88	52.85	132	264	Average
4904	45.57	60.23	74	-28.43	31.31	6.88	52.85	132	264	Peak

Remarks:

- Emission Level = Read Level + Antenna Factor + Cable Loss - Preamp Factor  
Margin value = Emission level – Limit value
- 2452 MHz: Fundamental frequency.
- The other emission levels were very low against the limit.

**9 kHz ~ 30 MHz Data:**

The amplitude of spurious emissions attenuated more than 20 dB below the permissible value is not required to be report.

**30 MHz ~ 1 GHz Worst-Case Data:**

**Mode A**

**802.11n (HT40)**

EUT Test Condition		Measurement Detail	
Channel	Channel 9	Frequency Range	30 MHz ~ 1 GHz
Input Power	120 Vac, 60 Hz	Detector Function	Peak (PK)
Environmental Conditions	25 deg. C, 65 % RH	Tested By	Jisyong Wang

Antenna Polarity & Test Distance: Horizontal at 3 m										
Frequency (MHz)	Emission Level (dBuV/m)	Read Level (dBuV)	Limit (dBuV/m)	Margin (dB)	Antenna Factor (dB/m)	Cable Loss (dB)	Preamp Factor (dB)	Antenna Height (cm)	Table Angle (Degree)	Remark
43.58	21.46	38.48	40	-18.54	13.59	0.5	31.11	113	290	Peak
127.97	27.78	47.23	43.5	-15.72	11.55	0.88	31.88	114	297	Peak
181.32	29.53	49.55	43.5	-13.97	10.67	1.13	31.82	100	200	Peak
240.49	35.09	54.37	46	-10.91	11.07	1.44	31.79	117	233	Peak
472.32	23.51	36.24	46	-22.49	16.77	2.38	31.88	119	266	Peak
798.24	28.55	34.1	46	-17.45	22.2	3.67	31.42	131	32	Peak
Antenna Polarity & Test Distance: Vertical at 3 m										
Frequency (MHz)	Emission Level (dBuV/m)	Read Level (dBuV)	Limit (dBuV/m)	Margin (dB)	Antenna Factor (dB/m)	Cable Loss (dB)	Preamp Factor (dB)	Antenna Height (cm)	Table Angle (Degree)	Remark
46.49	29.66	46.94	40	-10.34	13.39	0.52	31.19	127	206	Peak
69.77	35.15	55.56	40	-4.85	10.77	0.64	31.82	139	166	Peak
180.35	26.94	46.92	43.5	-16.56	10.74	1.12	31.84	122	163	Peak
353.98	21.78	37.53	46	-24.22	14.24	1.9	31.89	132	178	Peak
500.45	25.78	37.55	46	-20.22	17.33	2.52	31.62	131	192	Peak
823.46	27.33	32.68	46	-18.67	22.53	3.76	31.64	118	299	Peak

Remarks:

1. Emission Level = Read Level + Antenna Factor + Cable Loss - Preamp Factor
2. Margin value = Emission level – Limit value
3. The other emission levels were very low against the limit.

**Mode B**  
**802.11b**

EUT Test Condition		Measurement Detail	
Channel	Channel 11	Frequency Range	30 MHz ~ 1 GHz
Input Power	120 Vac, 60 Hz	Detector Function	Peak (PK)
Environmental Conditions	25 deg. C, 65 % RH	Tested By	Jisyong Wang

Antenna Polarity & Test Distance: Horizontal at 3 m										
Frequency (MHz)	Emission Level (dBuV/m)	Read Level (dBuV)	Limit (dBuV/m)	Margin (dB)	Antenna Factor (dB/m)	Cable Loss (dB)	Preamp Factor (dB)	Antenna Height (cm)	Table Angle (Degree)	Remark
288.02	41.43	58.92	46	-4.57	12.6	1.61	31.7	102	222	Peak
336.52	43.06	59.24	46	-2.94	13.82	1.82	31.82	111	165	Peak
432.55	42.5	56.33	46	-3.5	15.98	2.2	32.01	174	185	Peak
480.08	43.4	55.91	46	-2.6	16.93	2.41	31.85	103	251	Peak
599.39	32.57	42.32	46	-13.43	19.59	2.9	32.24	165	295	Peak
912.7	35.2	39.56	46	-10.8	23.58	4.1	32.04	111	185	Peak
Antenna Polarity & Test Distance: Vertical at 3 m										
Frequency (MHz)	Emission Level (dBuV/m)	Read Level (dBuV)	Limit (dBuV/m)	Margin (dB)	Antenna Factor (dB/m)	Cable Loss (dB)	Preamp Factor (dB)	Antenna Height (cm)	Table Angle (Degree)	Remark
144.46	29.37	47.54	43.5	-14.13	12.51	0.95	31.63	165	231	Peak
336.52	32.5	48.68	46	-13.5	13.82	1.82	31.82	111	195	Peak
384.05	35.75	50.76	46	-10.25	14.96	2.02	31.99	174	182	Peak
528.58	35.94	47.03	46	-10.06	17.97	2.62	31.68	132	251	Peak
576.11	34.32	44.56	46	-11.68	19.06	2.8	32.1	165	295	Peak
912.7	36.03	40.39	46	-9.97	23.58	4.1	32.04	111	152	Peak

Remarks:

1. Emission Level = Read Level + Antenna Factor + Cable Loss - Preamp Factor
2. Margin value = Emission level – Limit value
3. The other emission levels were very low against the limit.



## 4.2 Conducted Emission Measurement

### 4.2.1 Limits of Conducted Emission Measurement

Frequency (MHz)	Conducted Limit (dBuV)	
	Quasi-Peak	Average
0.15 - 0.5	66 - 56	56 - 46
0.50 - 5.0	56	46
5.0 - 30.0	60	50

- Note: 1. The lower limit shall apply at the transition frequencies.  
 2. The limit decreases in line with the logarithm of the frequency in the range of 0.15 to 0.50 MHz.

### 4.2.2 Test Instruments

Description & Manufacturer	Model No.	Serial No.	Date of Calibration	Due Date of Calibration
Test Receiver ROHDE & SCHWARZ	ESCI	100613	Nov. 23, 2017	Nov. 22, 2018
RF signal cable Woken	5D-FB	Cable-cond1-01	Sep. 05, 2018	Sep. 04, 2019
LISN/AMN ROHDE & SCHWARZ (EUT)	ENV216	101826	Feb. 26, 2018	Feb. 25, 2019
LISN/AMN ROHDE & SCHWARZ (Peripheral)	ESH3-Z5	100311	Aug. 19, 2018	Aug. 18, 2019
Software ADT	BV ADT_Cond_ V7.3.7.4	NA	NA	NA

- Note: 1. The calibration interval of the above test instruments is 12 months and the calibrations are traceable to NML/ROC and NIST/USA.  
 2. The test was performed in HwaYa Shielded Room 1.  
 3. The VCCI Site Registration No. is C-2040.

#### 4.2.3 Test Procedures

- a. The EUT was placed 0.4 meters from the conducting wall of the shielded room with EUT being connected to the power mains through a line impedance stabilization network (LISN). Other support units were connected to the power mains through another LISN. The two LISNs provide 50 ohm/50 uH of coupling impedance for the measuring instrument.
- b. Both lines of the power mains connected to the EUT were checked for maximum conducted interference.
- c. The frequency range from 150 kHz to 30 MHz was searched. Emission levels under (Limit – 20 dB) was not recorded.

**Note:** The resolution bandwidth and video bandwidth of test receiver is 9 kHz for quasi-peak detection (QP) and average detection (AV) at frequency 0.15 MHz – 30 MHz.

#### 4.2.4 Deviation from Test Standard

No deviation.

#### 4.2.5 Test Setup

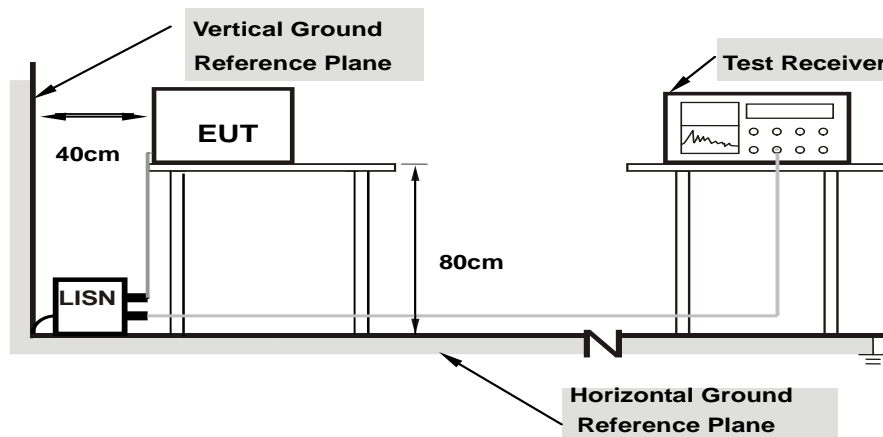

**Note:** 1.Support units were connected to second LISN.

For the actual test configuration, please refer to the attached file (Test Setup Photo).

#### 4.2.6 EUT Operating Conditions

- a. Placed the EUT on a testing table.
- b. Use the software to control the EUT under transmission condition continuously at specific channel frequency.

#### 4.2.7 Test Results

##### Mode A

Frequency Range	150kHz ~ 30MHz	Detector Function & Resolution Bandwidth	Quasi-Peak (QP) / Average (AV), 9kHz
Input Power	120Vac, 60Hz	Environmental Conditions	25°C, 65%RH
Tested by	Getaz Yang	Test Date	2018/9/9

Phase Of Power : Line (L)										
No	Frequency (MHz)	Correction Factor (dB)	Reading Value (dBuV)		Emission Level (dBuV)		Limit (dBuV)		Margin (dB)	
			Q.P.	AV.	Q.P.	AV.	Q.P.	AV.	Q.P.	AV.
1	0.15800	10.39	34.97	20.22	45.36	30.61	65.57	55.57	-20.21	-24.96
2	0.18228	10.39	30.23	16.27	40.62	26.66	64.38	54.38	-23.76	-27.72
3	0.22624	10.40	22.99	10.05	33.39	20.45	62.59	52.59	-29.20	-32.14
4	0.34214	10.40	11.84	3.14	22.24	13.54	59.15	49.15	-36.91	-35.61
5	0.49476	10.41	10.82	6.63	21.23	17.04	56.09	46.09	-34.86	-29.05
6	4.94200	10.60	9.43	3.26	20.03	13.86	56.00	46.00	-35.97	-32.14

##### Remarks:

1. Q.P. and AV. are abbreviations of quasi-peak and average individually.
2. The emission levels of other frequencies were very low against the limit.
3. Margin value = Emission level – Limit value
4. Correction factor = Insertion loss + Cable loss
5. Emission Level = Correction Factor + Reading Value

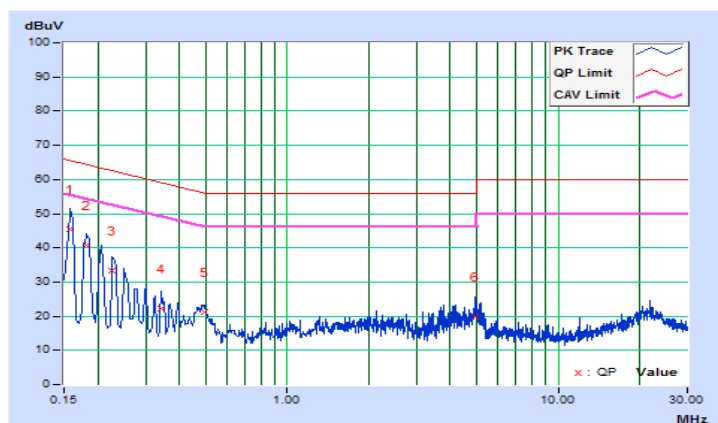

Frequency Range	150kHz ~ 30MHz	Detector Function & Resolution Bandwidth	Quasi-Peak (QP) / Average (AV), 9kHz
Input Power	120Vac, 60Hz	Environmental Conditions	25°C, 65%RH
Tested by	Getaz Yang	Test Date	2018/9/9

Phase Of Power : Neutral (N)										
No	Frequency (MHz)	Correction Factor (dB)	Reading Value (dBuV)		Emission Level (dBuV)		Limit (dBuV)		Margin (dB)	
			Q.P.	AV.	Q.P.	AV.	Q.P.	AV.	Q.P.	AV.
1	<b>0.15400</b>	<b>10.15</b>	<b>35.82</b>	<b>20.97</b>	<b>45.97</b>	<b>31.12</b>	<b>65.78</b>	<b>55.78</b>	<b>-19.81</b>	<b>-24.66</b>
2	0.17801	10.16	31.71	17.48	41.87	27.64	64.58	54.58	-22.71	-26.94
3	0.22200	10.16	26.33	12.49	36.49	22.65	62.74	52.74	-26.25	-30.09
4	0.48200	10.17	14.05	8.89	24.22	19.06	56.30	46.30	-32.08	-27.24
5	5.03800	10.37	7.16	0.64	17.53	11.01	60.00	50.00	-42.47	-38.99
6	21.57801	11.01	6.95	1.26	17.96	12.27	60.00	50.00	-42.04	-37.73

Remarks:

1. Q.P. and AV. are abbreviations of quasi-peak and average individually.
2. The emission levels of other frequencies were very low against the limit.
3. Margin value = Emission level – Limit value
4. Correction factor = Insertion loss + Cable loss
5. Emission Level = Correction Factor + Reading Value

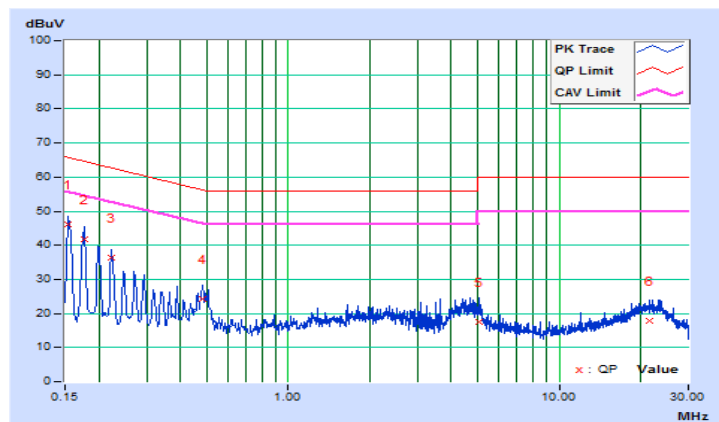

**Mode B**

Frequency Range	150kHz ~ 30MHz	Detector Function & Resolution Bandwidth	Quasi-Peak (QP) / Average (AV), 9kHz
Input Power	120Vac, 60Hz	Environmental Conditions	25°C, 65%RH
Tested by	Jisyong Wang	Test Date	2018/9/9

Phase Of Power : Line (L)										
No	Frequency (MHz)	Correction Factor (dB)	Reading Value (dBuV)		Emission Level (dBuV)		Limit (dBuV)		Margin (dB)	
			Q.P.	AV.	Q.P.	AV.	Q.P.	AV.	Q.P.	AV.
1	0.15391	9.67	36.31	20.18	45.98	29.85	65.79	55.79	-19.81	-25.94
2	0.18128	9.67	31.57	16.63	41.24	26.30	64.43	54.43	-23.19	-28.13
3	0.20893	9.67	27.57	13.32	37.24	22.99	63.25	53.25	-26.01	-30.26
4	0.23993	9.67	22.48	9.22	32.15	18.89	62.10	52.10	-29.95	-33.21
5	0.47844	9.66	16.27	3.90	25.93	13.56	56.37	46.37	-30.44	-32.81
6	23.98927	9.91	21.20	8.79	31.11	18.70	60.00	50.00	-28.89	-31.30

Remarks:

1. Q.P. and AV. are abbreviations of quasi-peak and average individually.
2. The emission levels of other frequencies were very low against the limit.
3. Margin value = Emission level – Limit value
4. Correction factor = Insertion loss + Cable loss
5. Emission Level = Correction Factor + Reading Value

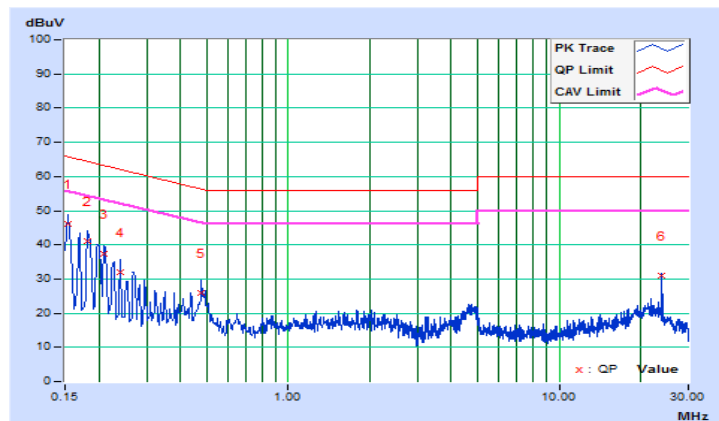

Frequency Range	150kHz ~ 30MHz	Detector Function & Resolution Bandwidth	Quasi-Peak (QP) / Average (AV), 9kHz
Input Power	120Vac, 60Hz	Environmental Conditions	25°C, 65%RH
Tested by	Jisyong Wang	Test Date	2018/9/9

Phase Of Power : Neutral (N)										
No	Frequency (MHz)	Correction Factor (dB)	Reading Value (dBuV)		Emission Level (dBuV)		Limit (dBuV)		Margin (dB)	
			Q.P.	AV.	Q.P.	AV.	Q.P.	AV.	Q.P.	AV.
1	0.16173	9.68	35.15	19.71	44.83	29.39	65.37	55.37	-20.54	-25.98
2	0.19692	9.67	29.16	14.94	38.83	24.61	63.74	53.74	-24.91	-29.13
3	0.21508	9.67	25.42	11.96	35.09	21.63	63.01	53.01	-27.92	-31.38
4	0.24796	9.67	20.50	8.00	30.17	17.67	61.83	51.83	-31.66	-34.16
5	0.48935	9.67	16.89	3.86	26.56	13.53	56.18	46.18	-29.62	-32.65
6	23.98927	10.03	20.87	7.18	30.90	17.21	60.00	50.00	-29.10	-32.79

Remarks:

1. Q.P. and AV. are abbreviations of quasi-peak and average individually.
2. The emission levels of other frequencies were very low against the limit.
3. Margin value = Emission level – Limit value
4. Correction factor = Insertion loss + Cable loss
5. Emission Level = Correction Factor + Reading Value

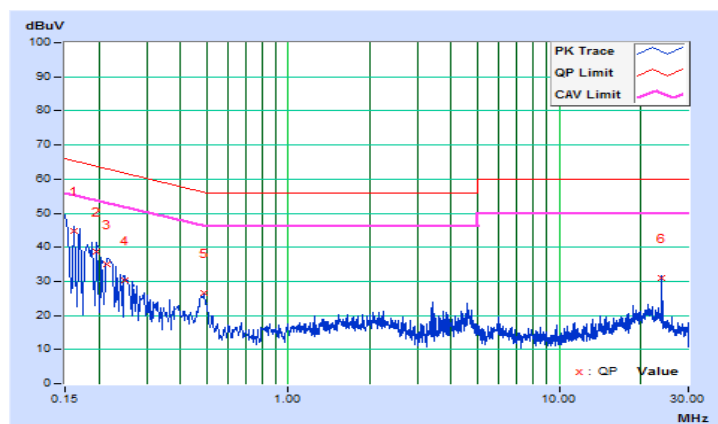

## 5 Pictures of Test Arrangements

Please refer to the attached file (Test Setup Photo).

## Appendix – Information on the Testing Laboratories

We, Bureau Veritas Consumer Products Services (H.K.) Ltd., Taoyuan Branch, were founded in 1988 to provide our best service in EMC, Radio, Telecom and Safety consultation. Our laboratories are FCC recognized accredited test firms and accredited according to ISO/IEC 17025.

If you have any comments, please feel free to contact us at the following:

**Linko EMC/RF Lab**

Tel: 886-2-26052180

Fax: 886-2-26051924

**Hsin Chu EMC/RF/Telecom Lab**

Tel: 886-3-6668565

Fax: 886-3-6668323

**Hwa Ya EMC/RF/Safety Lab**

Tel: 886-3-3183232

Fax: 886-3-3270892

**Email:** [service.adt@tw.bureauveritas.com](mailto:service.adt@tw.bureauveritas.com)

**Web Site:** [www.bureauveritas-adt.com](http://www.bureauveritas-adt.com)

The address and road map of all our labs can be found in our web site also.

--- END ---