

## Variant FCC Test Report

**Report No.:** RF170818C25B-2

**FCC ID:** 2ADWC-AI7697HD

**Test Model:** AI7697HD

**Received Date:** Aug. 30, 2018

**Test Date:** Sep. 09, 2018 ~ Sep. 18, 2018

**Issued Date:** Sep. 21, 2018

**Applicant:** AcSiP Technology Corporation

**Address:** 3F.-1, No.207, Fusing Rd., Taoyuan Dist., Taoyuan County 330, Taiwan  
(R.O.C.)

**Issued By:** Bureau Veritas Consumer Products Services (H.K.) Ltd., Taoyuan Branch

**Lab Address:** No. 47-2, 14th Ling, Chia Pau Vil., Lin Kou Dist., New Taipei City, Taiwan  
( R.O.C )

**Test Location:** No. 19, Hwa Ya 2nd Rd, Wen Hwa Tsuen, Kwei Shan Hsiang, Taoyuan  
Hsien 333, Taiwan, R.O.C.

**FCC Registration /  
Designation Number:** 788550 / TW0003



This report is for your exclusive use. Any copying or replication of this report to or for any other person or entity, or use of our name or trademark, is permitted only with our prior written permission. This report sets forth our findings solely with respect to the test samples identified herein. The results set forth in this report are not indicative or representative of the quality or characteristics of the lot from which a test sample was taken or any similar or identical product unless specifically and expressly noted. Our report includes all of the tests requested by you and the results thereof based upon the information that you provided to us. You have 60 days from date of issuance of this report to notify us of any material error or omission caused by our negligence, provided, however, that such notice shall be in writing and shall specifically address the issue you wish to raise. A failure to raise such issue within the prescribed time shall constitute your unqualified acceptance of the completeness of this report, the tests conducted and the correctness of the report contents. Unless specific mention, the uncertainty of measurement has been explicitly taken into account to declare the compliance or non-compliance to the specification. The report must not be used by the client to claim product certification, approval, or endorsement by TAF or any government agencies.

## Table of Contents

<b>Release Control Record .....</b>	<b>3</b>
<b>1 Certificate of Conformity .....</b>	<b>4</b>
<b>2 Summary of Test Results.....</b>	<b>5</b>
2.1 Measurement Uncertainty.....	5
2.2 Modification Record .....	5
<b>3 General Information .....</b>	<b>6</b>
3.1 General Description of EUT .....	6
3.2 Description of Test Modes.....	7
3.2.1 Test Mode Applicability and Tested Channel Detail.....	8
3.3 Description of Support Units .....	9
3.3.1 Configuration of System under Test .....	9
3.4 General Description of Applied Standards.....	9
<b>4 Test Types and Results .....</b>	<b>10</b>
4.1 Radiated Emission and Bandedge Measurement .....	10
4.1.1 Limits of Radiated Emission and Bandedge Measurement .....	10
4.1.2 Limits of Unwanted Emission Out of the Restricted Bands.....	11
4.1.3 Test Instruments .....	12
4.1.4 Test Procedures.....	13
4.1.5 Deviation from Test Standard .....	14
4.1.6 Test Setup.....	14
4.1.7 EUT Operating Conditions.....	15
4.1.8 Test Results .....	16
4.2 Conducted Emission Measurement.....	50
4.2.1 Limits of Conducted Emission Measurement .....	50
4.2.2 Test Instruments .....	50
4.2.3 Test Procedures.....	51
4.2.4 Deviation from Test Standard .....	51
4.2.5 Test Setup.....	51
4.2.6 EUT Operating Conditions.....	51
4.2.7 Test Results .....	52
<b>5 Pictures of Test Arrangements.....</b>	<b>56</b>
<b>Annex A- Radiated Out of Band Emisison (OOBE) Measurement (For U-NII-3 band).....</b>	<b>57</b>
<b>Appendix – Information on the Testing Laboratories .....</b>	<b>63</b>

### Release Control Record

Issue No.	Description	Date Issued
RF170818C25B-2	Original Release	Sep. 21, 2018

## 1 Certificate of Conformity

**Product:** 802.11 IoT Module

**Brand:** AcSiP

**Test Model:** AI7697HD

**Sample Status:** Production Unit

**Applicant:** AcSiP Technology Corporation

**Test Date:** Sep. 09, 2018 ~ Sep. 18, 2018

**Standards:** 47 CFR FCC Part 15, Subpart E (Section 15.407)  
ANSI C63.10:2013

This report is issued as a supplementary report to BV CPS report no.: RF170818C25-2. This report shall be used by combining with its original report.

**Prepared by :** Gina Liu , **Date:** Sep. 21, 2018  
Gina Liu / Specialist

**Approved by :** Dylan Chiou , **Date:** Sep. 21, 2018  
Dylan Chiou / Project Engineer

## 2 Summary of Test Results

47 CFR FCC Part 15, Subpart E (Section 15.407)			
FCC Clause	Test Item	Result	Remarks
15.407(b)(6)	AC Power Conducted Emissions	Pass	Meet the requirement of limit. Minimum passing margin is -19.34 dB at 0.15000 MHz.
15.407(b)(1/2/3/4(i/ii)/6)	Radiated Emissions & Band Edge Measurement	Pass	Meet the requirement of limit. Minimum passing margin is -1.39 dB at 5148.8 MHz.
15.407(a)(1/2/3)	Max Average Transmit Power	N/A	Refer to Note
---	Occupied Bandwidth Measurement	N/A	Refer to Note
15.407(a)(1/2/3)	Peak Power Spectral Density	N/A	Refer to Note
15.407(e)	6 dB Bandwidth	N/A	Refer to Note
15.407(g)	Frequency Stability	N/A	Refer to Note
15.203	Antenna Requirement	N/A	Refer to Note

\*For U-NII-3 band compliance with rule part 15.407(b)(4)(i), the OOB test plots were recorded in Annex A.

**Note:** Only conducted emission and radiated emission tests had been performed for the addendum. Refer to original report for other test data.

### 2.1 Measurement Uncertainty

Where relevant, the following measurement uncertainty levels have been estimated for tests performed on the EUT as specified in CISPR 16-4-2:

Measurement	Frequency	Expanded Uncertainty (k=2) (±)
Conducted Emissions at mains ports	150 kHz ~ 30 MHz	2.44 dB
Radiated Emissions up to 1 GHz	30 MHz ~ 200 MHz	2.93 dB
	200 MHz ~ 1000 MHz	2.95 dB
Radiated Emissions above 1 GHz	1 GHz ~ 18 GHz	2.26 dB
	18 GHz ~ 40 GHz	1.94 dB

### 2.2 Modification Record

There were no modifications required for compliance.

### 3 General Information

#### 3.1 General Description of EUT

<b>Product</b>	802.11 IoT Module
<b>Brand</b>	AcSiP
<b>Test Model</b>	AI7697HD
<b>Status of EUT</b>	Production Unit
<b>Power Supply Rating</b>	5.0 Vdc (host equipment)
<b>Modulation Type</b>	64QAM, 16QAM, QPSK, BPSK
<b>Modulation Technology</b>	OFDM
<b>Transfer Rate</b>	802.11a: 54.0/ 48.0/ 36.0/ 24.0/ 18.0/ 12.0/ 9.0/ 6.0 Mbps 802.11n: up to 150.0 Mbps
<b>Operating Frequency</b>	5180 ~ 5240 MHz, 5745 ~ 5825 MHz
<b>Number of Channel</b>	5180 ~ 5240 MHz: 4 for 802.11a, 802.11n (HT20) 2 for 802.11n (HT40) 5745 ~ 5825 MHz: 5 for 802.11a, 802.11n (HT20) 2 for 802.11n (HT40)
<b>Antenna Type</b>	Refer to Note as below
<b>Antenna Connector</b>	IPEX-MHF-4
<b>Accessory Device</b>	N/A
<b>Data Cable Supplied</b>	N/A

**Note:**

1. This report is issued as a supplementary report to BV CPS report no.: RF170818C25-2. The difference compared with original report is adding new antennas. Therefore, only conducted emission and radiated emission tests had been performed for this report.
2. The antenna information is listed as below.

SKU	Brand	Antenna Type	Model	Antenna Gain (dBi)		
				BT	WLAN 2.4 GHz	WLAN 5 GHz
1	Compal	Coupled	81.EKB15.G14	3.34	3.34	1.44
2		PIFA	DC33002520U	3.46	3.46	5.37

3. The above EUT information is declared by manufacturer and for more detailed features description, please refers to the manufacturer's specifications or user's manual.

### 3.2 Description of Test Modes

#### For 5180 ~ 5240 MHz

4 channels are provided for 802.11a, 802.11n (HT20):

Channel	Frequency (MHz)	Channel	Frequency (MHz)
36	5180	44	5220
40	5200	48	5240

2 channels are provided for 802.11n (HT40):

Channel	Frequency (MHz)	Channel	Frequency (MHz)
38	5190	46	5230

#### For 5745 ~ 5825 MHz:

5 channels are provided for 802.11a, 802.11n (HT20):

Channel	Frequency (MHz)	Channel	Frequency (MHz)
149	5745	161	5805
153	5765	165	5825
157	5785		

2 channels are provided for 802.11n (HT40):

Channel	Frequency (MHz)	Channel	Frequency (MHz)
151	5755	159	5795

### 3.2.1 Test Mode Applicability and Tested Channel Detail

EUT Configure Mode	Applicable To			Description
	RE $\geq$ 1G	RE $<$ 1G	PLC	
A	√	√	√	SKU 1
B	√	√	√	SKU 2

Where **RE $\geq$ 1G**: Radiated Emission above 1 GHz      **RE $<$ 1G**: Radiated Emission below 1 GHz  
**PLC**: Power Line Conducted Emission

**Note:**

- The EUT had been pre-tested on the positioned of each 3 axis. The worst case was found when positioned on **Y-plane** for Mode A and **X-plane** for Mode B.
- "-" means no effect.

#### **Radiated Emission Test (Above 1 GHz):**

- Pre-Scan has been conducted to determine the worst-case mode from all possible combinations between available modulations, data rates and antenna ports (if EUT with antenna diversity architecture).
- Following channel(s) was (were) selected for the final test as listed below.

EUT Configure Mode	Frequency Band (MHz)	Mode	Available Channel	Tested Channel	Modulation Technology	Modulation Type	Data Rate (Mbps)
A	5180-5240	802.11a	36 to 48	36, 44, 48	OFDM	BPSK	6.0
B				36, 40, 48			
A		802.11n (HT20)	36 to 48	36, 44, 48	OFDM	BPSK	6.5
B				36, 40, 48			
A, B	802.11n (HT40)	38 to 46	38, 46	OFDM	BPSK	13.5	
A, B	5745-5825	802.11a	149 to 165	149, 157, 165	OFDM	BPSK	6.0
		802.11n (HT20)	149 to 165	149, 157, 165	OFDM	BPSK	6.5
		802.11n (HT40)	151 to 159	151, 159	OFDM	BPSK	13.5

#### **Radiated Emission Test (Below 1 GHz):**

- Pre-Scan has been conducted to determine the worst-case mode from all possible combinations between available modulations, data rates and antenna ports (if EUT with antenna diversity architecture).
- Following channel(s) was (were) selected for the final test as listed below.

EUT Configure Mode	Frequency Band (MHz)	Mode	Available Channel	Tested Channel	Modulation Technology	Modulation Type	Data Rate (Mbps)
A	5180-5240	802.11n (HT40)	38 to 46	38	OFDM	BPSK	13.5
B	5745-5825	802.11a	149 to 165	157	OFDM	BPSK	6.0

#### **Power Line Conducted Emission Test:**

- Pre-Scan has been conducted to determine the worst-case mode from all possible combinations between available modulations, data rates and antenna ports (if EUT with antenna diversity architecture).
- Following channel(s) was (were) selected for the final test as listed below.

EUT Configure Mode	Frequency Band (MHz)	Mode	Available Channel	Tested Channel	Modulation Technology	Modulation Type	Data Rate (Mbps)
A	5180-5320	802.11n (HT40)	38 to 46	38	OFDM	BPSK	13.5
B	5745-5825	802.11a	149 to 165	157	OFDM	BPSK	6.0



**Test Condition:**

Applicable To	Environmental Conditions	Input Power	Tested by
RE≥1G	25 deg. C, 65 % RH	120 Vac, 60 Hz	Gavin Wu, Thomas Wei, Jisyong Wang
RE<1G	25 deg. C, 65 % RH	120 Vac, 60 Hz	Jisyong Wang
PLC	25 deg. C, 65 % RH	120 Vac, 60 Hz	Getaz Yang, Jisyong Wang

**3.3 Description of Support Units**

The EUT has been tested as an independent unit together with other necessary accessories or support units. The following support units or accessories were used to form a representative test configuration during the tests.

No.	Product	Brand	Model No.	Serial No.	FCC ID
1.	NB	N/A	N/A	N/A	N/A

No.	Signal Cable Description Of The Above Support Units
1.	N/A
2.	

Note:

1. All power cords of the above support units are non-shielded (1.8m).

**3.3.1 Configuration of System under Test**

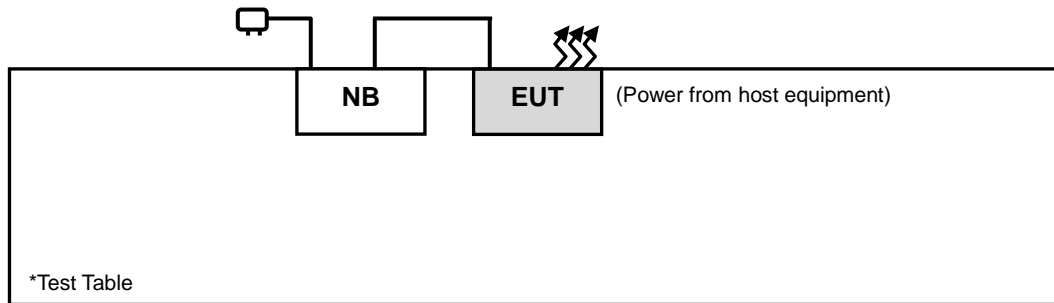

**3.4 General Description of Applied Standards**

The EUT is a RF Product. According to the specifications of the manufacturer, it must comply with the requirements of the following standards:

**FCC Part 15, Subpart E (15.407)**

**KDB 789033 D02 General UNII Test Procedures New Rules v02r01**

ANSI C63.10-2013

All test items have been performed and recorded as per the above standards.

## 4 Test Types and Results

### 4.1 Radiated Emission and Bandedge Measurement

#### 4.1.1 Limits of Radiated Emission and Bandedge Measurement

Radiated emissions which fall in the restricted bands must comply with the radiated emission limits specified as below table. Other emissions shall be at least 20 dB below the highest level of the desired power:

Frequencies (MHz)	Field Strength (microvolts/meter)	Measurement Distance (meters)
0.009 ~ 0.490	2400/F (kHz)	300
0.490 ~ 1.705	24000/F (kHz)	30
1.705 ~ 30.0	30	30
30 ~ 88	100	3
88 ~ 216	150	3
216 ~ 960	200	3
Above 960	500	3

**Note:**

1. The lower limit shall apply at the transition frequencies.
2. Emission level (dBuV/m) = 20 log Emission level (uV/m).
3. For frequencies above 1000 MHz, the field strength limits are based on average detector, however, the peak field strength of any emission shall not exceed the maximum permitted average limits, specified above by more than 20 dB under any condition of modulation.

## 4.1.2 Limits of Unwanted Emission Out of the Restricted Bands

Applicable To		Limit	
789033 D02 General UNII Test Procedures New Rules v02r01		Field Strength at 3 m	
		PK: 74 (dBµV/m)	AV: 54 (dBµV/m)
Frequency Band	Applicable To	EIRP Limit	Equivalent Field Strength at 3 m
5150~5250 MHz	15.407(b)(1)	PK: -27 (dBm/MHz)	PK: 68.2 (dBµV/m)
5250~5350 MHz	15.407(b)(2)		
5470~5725 MHz	15.407(b)(3)		
5725~5850 MHz	15.407(b)(4)(i)	PK:-27 (dBm/MHz) <sup>*1</sup> PK:10 (dBm/MHz) <sup>*2</sup> PK:15.6 (dBm/MHz) <sup>*3</sup> PK:27 (dBm/MHz) <sup>*4</sup>	PK: 68.2 (dBµV/m) <sup>*1</sup> PK:105.2 (dBµV/m) <sup>*2</sup> PK: 110.8 (dBµV/m) <sup>*3</sup> PK:122.2 (dBµV/m) <sup>*4</sup>
	15.407(b)(4)(ii)	Emission limits in section 15.247(d)	
<sup>*1</sup> beyond 75 MHz or more above of the band edge. <sup>*2</sup> below the band edge increasing linearly to 10 dBm/MHz at 25 MHz above. <sup>*3</sup> below the band edge increasing linearly to a level of 15.6 dBm/MHz at 5 MHz above. <sup>*4</sup> from 5 MHz above or below the band edge increasing linearly to a level of 27 dBm/MHz at the band edge.			

**Note:**

The following formula is used to convert the equipment isotropic radiated power (eirp) to field strength:

$$E = \frac{1000000\sqrt{30P}}{3} \mu\text{V/m, where } P \text{ is the eirp (Watts).}$$

#### 4.1.3 Test Instruments

Description & Manufacturer	Model No.	Serial No.	Date of Calibration	Due Date of Calibration
Test Receiver Agilent	N9038A	MY51210203	Mar. 16, 2018	Mar. 15, 2019
Spectrum Analyzer Agilent	N9010A	MY52220314	Nov. 24, 2017	Nov. 23, 2018
Spectrum Analyzer ROHDE & SCHWARZ	FSU43	101261	Jan. 11, 2018	Jan. 10, 2019
BILOG Antenna SCHWARZBECK	VULB 9168	9168-472	Dec. 06, 2017	Dec. 05, 2018
Horn Antenna SCHWARZBECK	BBHA 9120D	9120D-969	Dec. 12, 2017	Dec. 11, 2018
HORN Antenna SCHWARZBECK	BBHA 9170	148	Dec. 13, 2017	Dec. 12, 2018
Fixed Attenuator Mini-Circuits	BW-N10W5+	1301	Aug. 13, 2018	Aug. 12, 2019
Loop Antenna	EM-6879	269	Sep. 07, 2018	Sep. 06, 2019
Preamplifier EMCI	EMC001340	980201	Nov. 01, 2017	Oct. 30, 2018
Preamplifier EMCI	EMC 012645	980115	Oct. 20, 2017	Oct. 19, 2018
Preamplifier EMCI	EMC 184045	980116	Oct. 20, 2017	Oct. 19, 2018
Preamplifier EMCI	EMC 330H	980112	Oct. 13, 2017	Oct. 12, 2018
Power Meter Anritsu	ML2495A	1012010	Sep. 05, 2018	Sep. 04, 2019
Power Sensor Anritsu	MA2411B	1315050	Sep. 04, 2018	Sep. 03, 2019
RF Coaxial Cable HUBER+SUHNNER	EMC104-SM-SM-8 000&3000	140811+170717	Oct. 20, 2017	Oct. 19, 2018
RF Coaxial Cable HUBER+SUHNNER	SUCOFLEX 104	EMC104-SM-SM-1 000(140807)	Oct. 20, 2017	Oct. 19, 2018
RF Coaxial Cable Worken	8D-FB	Cable-Ch10-01	Oct. 20, 2017	Oct. 19, 2018
Software BV ADT	E3 6.120103	NA	NA	NA
Antenna Tower MF	MFA-440H	NA	NA	NA
Turn Table MF	MFT-201SS	NA	NA	NA
Antenna Tower & Turn Table Controller MF	MF-7802	NA	NA	NA

- Note: 1. The calibration interval of the above test instruments is 12 months and the calibrations are traceable to NML/ROC and NIST/USA.
2. The test was performed in HwaYa Chamber 10.
3. The horn antenna and preamplifier (model: EMC 184045) are used only for the measurement of emission frequency above 1 GHz if tested.
4. The IC Site Registration No. is IC7450F-10.

#### 4.1.4 Test Procedures

##### **For Radiated Emission below 30 MHz**

- a. The EUT was placed on the top of a rotating table 0.8 meters above the ground at a 3 meter chamber room. The table was rotated 360 degrees to determine the position of the highest radiation.
- b. The EUT was set 3 meters away from the interference-receiving antenna, which was mounted on the top of a variable-height antenna tower.
- c. Both Parallel, perpendicular, and ground-parallel orientations of the antenna are set to make the measurement.
- d. For each suspected emission, the EUT was arranged to its worst case and the rotatable table was turned from 0 degrees to 360 degrees to find the maximum reading.
- e. The test-receiver system was set to Quasi-Peak Detect Function and Specified Bandwidth with Maximum Hold Mode.

##### **Note:**

1. The resolution bandwidth and video bandwidth of test receiver/spectrum analyzer is 9 kHz at frequency below 30 MHz.

##### **For Radiated Emission above 30 MHz**

- a. The EUT was placed on the top of a rotating table 0.8 meters (for 30 MHz ~ 1 GHz) / 1.5 meters (for above 1 GHz) above the ground at 3 meter chamber room for test. The table was rotated 360 degrees to determine the position of the highest radiation.
- b. The EUT was set 3 meters away from the interference-receiving antenna, which was mounted on the top of a variable-height antenna tower.
- c. The height of antenna is varied from one meter to four meters above the ground to determine the maximum value of the field strength. Both horizontal and vertical polarizations of the antenna are set to make the measurement.
- d. For each suspected emission, the EUT was arranged to its worst case and then the antenna was tuned to heights from 1 meter to 4 meters and the rotatable table was turned from 0 degrees to 360 degrees to find the maximum reading.
- e. The test-receiver system was set to quasi-peak detect function and specified bandwidth with maximum hold mode when the test frequency is below 1 GHz.
- f. The test-receiver system was set to peak and average detected function and specified bandwidth with maximum hold mode when the test frequency is above 1 GHz. If the peak reading value also meets average limit, measurement with the average detector is unnecessary.

##### **Note:**

1. The resolution bandwidth and video bandwidth of test receiver/spectrum analyzer is 120 kHz for Quasi-peak detection (QP) at frequency below 1 GHz.
2. The resolution bandwidth of test receiver/spectrum analyzer is 1 MHz and the video bandwidth is 3 MHz for Peak detection (PK) at frequency above 1 GHz.
3. The resolution bandwidth of test receiver/spectrum analyzer is 1 MHz and the video bandwidth is  $\geq 1/T$  (Duty cycle < 98 %) or 10 Hz (Duty cycle  $\geq 98$  %) for Average detection (AV) at frequency above 1 GHz.  
(11a: RBW = 1 MHz, VBW = 10 Hz ; 11n (HT20): RBW = 1 MHz, VBW = 10 Hz ;  
11n (HT40): RBW = 1 MHz, VBW = 10 Hz ; 11ac (VHT80): RBW = 1 MHz, VBW = 10 Hz)
4. All modes of operation were investigated and the worst-case emissions are reported.

4.1.5 Deviation from Test Standard

No deviation.

4.1.6 Test Setup

<Radiated Emission below 30 MHz>

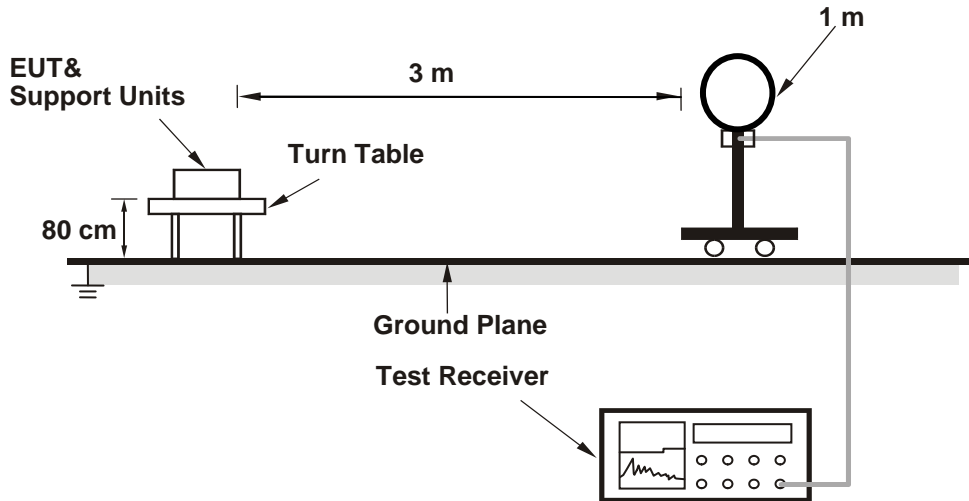

<Radiated Emission 30 MHz to 1 GHz>

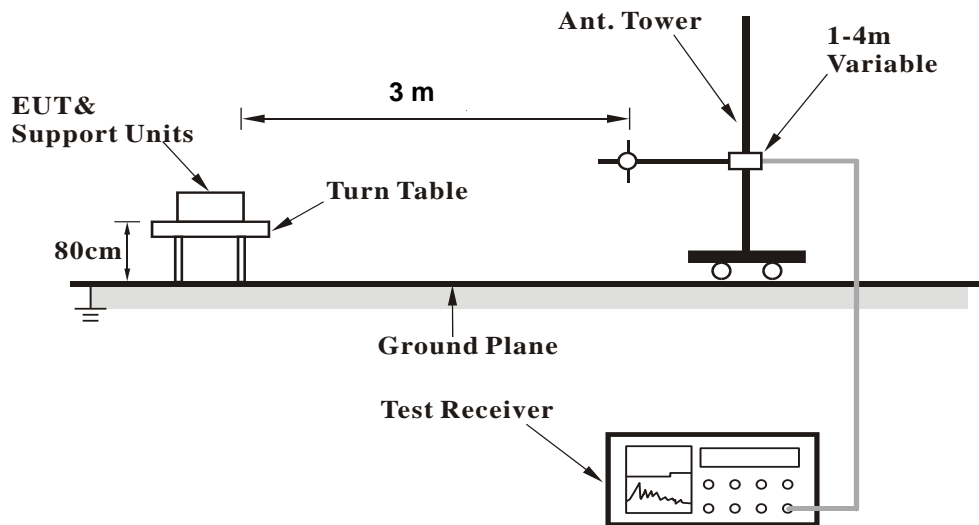

**<Radiated Emission above 1 GHz>**

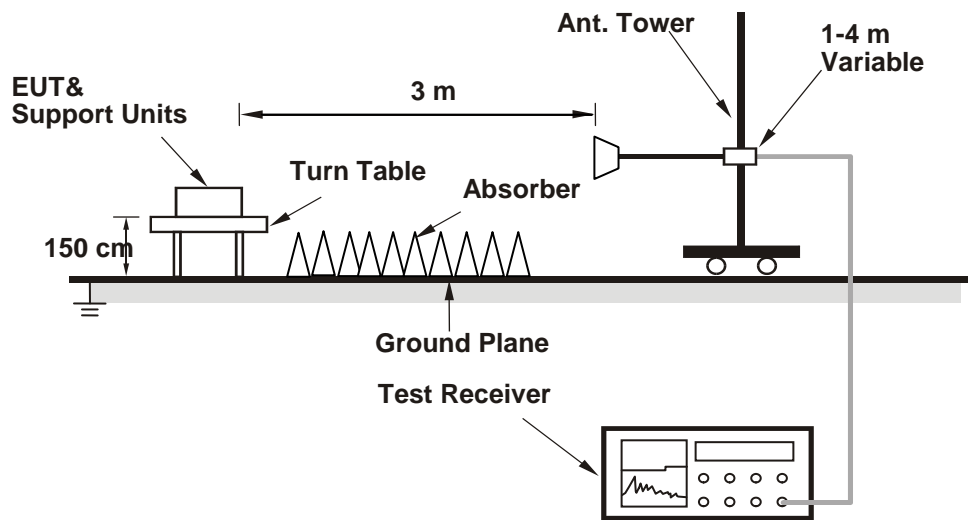

For the actual test configuration, please refer to the attached file (Test Setup Photo).

**4.1.7 EUT Operating Conditions**

- a. Placed the EUT on a testing table.
- b. Use the software to control the EUT under transmission condition continuously at specific channel frequency.

4.1.8 Test Results  
**Above 1 GHz Data :**  
**Mode A**  
**802.11a**

EUT Test Condition		Measurement Detail	
Channel	Channel 36	Frequency Range	1 GHz ~ 40 GHz
Input Power	120 Vac, 60 Hz	Detector Function	Peak (PK) Average (AV)
Environmental Conditions	25 deg. C, 65 % RH	Tested By	Gavin Wu

Antenna Polarity & Test Distance: Horizontal at 3 m										
Frequency (MHz)	Emission Level (dBuV/m)	Read Level (dBuV)	Limit (dBuV/m)	Margin (dB)	Antenna Factor (dB/m)	Cable Loss (dB)	Preamp Factor (dB)	Antenna Height (cm)	Table Angle (Degree)	Remark
5146.1	43.66	58.31	54	-10.34	31.32	7.04	53.01	128	3	Average
5146.1	55.6	55.26	74	-18.4	31.32	6.34	37.32	128	3	Peak
5180	96.46	96.08			31.35	6.37	37.34	128	3	Average
5180	105.13	104.75			31.35	6.37	37.34	128	3	Peak
*10360	56.89	59.94	68.2	-11.31	39.19	10.21	52.45	115	212	Peak

Antenna Polarity & Test Distance: Vertical at 3 m										
Frequency (MHz)	Emission Level (dBuV/m)	Read Level (dBuV)	Limit (dBuV/m)	Margin (dB)	Antenna Factor (dB/m)	Cable Loss (dB)	Preamp Factor (dB)	Antenna Height (cm)	Table Angle (Degree)	Remark
5148.5	40.77	55.19	54	-13.23	31.32	7.04	52.78	240	53	Average
5148.5	54.65	54.31	74	-19.35	31.32	6.34	37.32	240	53	Peak
5180	93.34	92.96			31.35	6.37	37.34	240	53	Average
5180	102.35	101.97			31.35	6.37	37.34	240	53	Peak
*10360	56.23	58.97	68.2	-11.97	39.19	10.21	52.14	100	108	Peak

Remarks:

- Emission Level = Read Level + Antenna Factor + Cable Loss - Preamp Factor  
Margin value = Emission level – Limit value
- 5180 MHz: Fundamental Frequency
- \*: Out of Restricted Band
- The other emission levels were very low against the limit.



EUT Test Condition		Measurement Detail	
Channel	Channel 44	Frequency Range	1 GHz ~ 40 GHz
Input Power	120 Vac, 60 Hz	Detector Function	Peak (PK) Average (AV)
Environmental Conditions	25 deg. C, 65 % RH	Tested By	Gavin Wu

Antenna Polarity & Test Distance: Horizontal at 3 m										
Frequency (MHz)	Emission Level (dBuV/m)	Read Level (dBuV)	Limit (dBuV/m)	Margin (dB)	Antenna Factor (dB/m)	Cable Loss (dB)	Preamp Factor (dB)	Antenna Height (cm)	Table Angle (Degree)	Remark
5137.7	42.11	56.8	54	-11.89	31.31	7.03	53.03	140	3	Average
5137.7	53.44	53.1	74	-20.56	31.31	6.33	37.3	140	3	Peak
5220	96.35	95.94			31.37	6.4	37.36	140	3	Average
5220	105.13	104.72			31.37	6.4	37.36	140	3	Peak
5392.13	39.65	53.75	54	-14.35	31.51	7.17	52.78	140	3	Average
5392.13	51.77	50.97	74	-22.23	31.51	6.47	37.18	140	3	Peak
*10440	56.8	59.82	68.2	-11.4	39.29	10.21	52.52	115	212	Peak
Antenna Polarity & Test Distance: Vertical at 3 m										
Frequency (MHz)	Emission Level (dBuV/m)	Read Level (dBuV)	Limit (dBuV/m)	Margin (dB)	Antenna Factor (dB/m)	Cable Loss (dB)	Preamp Factor (dB)	Antenna Height (cm)	Table Angle (Degree)	Remark
5105.6	39.86	54.43	54	-14.14	31.29	7	52.86	233	69	Average
5105.6	52.14	51.83	74	-21.86	31.29	6.3	37.28	233	69	Peak
5220	93.09	92.68			31.37	6.4	37.36	233	69	Average
5220	102	101.59			31.37	6.4	37.36	233	69	Peak
5445.48	38.86	52.69	54	-15.14	31.55	7.21	52.59	233	69	Average
5445.48	51.32	50.4	74	-22.68	31.55	6.5	37.13	233	69	Peak
*10440	55.25	58.23	68.2	-12.95	39.29	10.21	52.48	100	108	Peak

Remarks:

- Emission Level = Read Level + Antenna Factor + Cable Loss - Preamp Factor  
Margin value = Emission level – Limit value
- 5220 MHz: Fundamental Frequency
- \*: Out of Restricted Band
- The other emission levels were very low against the limit.

EUT Test Condition		Measurement Detail	
Channel	Channel 48	Frequency Range	1 GHz ~ 40 GHz
Input Power	120 Vac, 60 Hz	Detector Function	Peak (PK) Average (AV)
Environmental Conditions	25 deg. C, 65 % RH	Tested By	Gavin Wu

Antenna Polarity & Test Distance: Horizontal at 3 m										
Frequency (MHz)	Emission Level (dBuV/m)	Read Level (dBuV)	Limit (dBuV/m)	Margin (dB)	Antenna Factor (dB/m)	Cable Loss (dB)	Preamp Factor (dB)	Antenna Height (cm)	Table Angle (Degree)	Remark
5135.75	40.63	55.32	54	-13.37	31.31	7.03	53.03	117	4	Average
5135.75	52.1	51.76	74	-21.9	31.31	6.33	37.3	117	4	Peak
5240	96.75	96.26			31.39	6.42	37.32	117	4	Average
5240	105.84	105.35			31.39	6.42	37.32	117	4	Peak
5360.89	39.4	53.56	54	-14.6	31.49	7.18	52.83	117	4	Average
5360.89	51.49	50.71	74	-22.51	31.49	6.47	37.18	117	4	Peak
*10480	57.11	60.18	68.2	-11.09	39.37	10.22	52.66	115	212	Peak
Antenna Polarity & Test Distance: Vertical at 3 m										
Frequency (MHz)	Emission Level (dBuV/m)	Read Level (dBuV)	Limit (dBuV/m)	Margin (dB)	Antenna Factor (dB/m)	Cable Loss (dB)	Preamp Factor (dB)	Antenna Height (cm)	Table Angle (Degree)	Remark
5148.5	39.43	53.85	54	-14.57	31.32	7.04	52.78	232	62	Average
5148.5	52	51.66	74	-22	31.32	6.34	37.32	232	62	Peak
5240	92.89	92.4			31.39	6.42	37.32	232	62	Average
5240	102.07	101.58			31.39	6.42	37.32	232	62	Peak
5354.95	39.08	53.16	54	-14.92	31.48	7.18	52.74	232	62	Average
5354.95	51.63	50.86	74	-22.37	31.48	6.47	37.18	232	62	Peak
*10480	56.01	59.13	68.2	-12.19	39.37	10.22	52.71	100	108	Peak

Remarks:

- Emission Level = Read Level + Antenna Factor + Cable Loss - Preamp Factor  
Margin value = Emission level – Limit value
- 5240 MHz: Fundamental Frequency
- \*: Out of Restricted Band
- The other emission levels were very low against the limit.

EUT Test Condition		Measurement Detail	
Channel	Channel 149	Frequency Range	1 GHz ~ 40 GHz
Input Power	120 Vac, 60 Hz	Detector Function	Peak (PK) Average (AV)
Environmental Conditions	25 deg. C, 65 % RH	Tested By	Gavin Wu

### <Spurious Emission>

Antenna Polarity & Test Distance: Horizontal at 3 m										
Frequency (MHz)	Emission Level (dBuV/m)	Read Level (dBuV)	Limit (dBuV/m)	Margin (dB)	Antenna Factor (dB/m)	Cable Loss (dB)	Preamp Factor (dB)	Antenna Height (cm)	Table Angle (Degree)	Remark
5745	96.86	95.56			31.99	6.78	37.47	148	350	Average
5745	105.52	104.22			31.99	6.78	37.47	148	350	Peak
11490	48.6	50.81	54	-5.4	39.91	10.66	52.78	100	353	Average
11490	59.87	62.08	74	-14.13	39.91	10.66	52.78	100	353	Peak
Antenna Polarity & Test Distance: Vertical at 3 m										
Frequency (MHz)	Emission Level (dBuV/m)	Read Level (dBuV)	Limit (dBuV/m)	Margin (dB)	Antenna Factor (dB/m)	Cable Loss (dB)	Preamp Factor (dB)	Antenna Height (cm)	Table Angle (Degree)	Remark
5745	95.44	94.17			31.99	6.75	37.47	222	42	Average
5745	104.38	103.11			31.99	6.75	37.47	222	42	Peak
11490	46.42	48.63	54	-7.58	39.91	10.66	52.78	172	25	Average
11490	56.88	59.09	74	-17.12	39.91	10.66	52.78	172	25	Peak

### <Out of Band Emission (OOBE)>

Antenna Polarity & Test Distance: Horizontal at 3 m										
Frequency (MHz)	Emission Level (dBuV/m)	Read Level (dBuV)	Limit (dBuV/m)	Margin (dB)	Antenna Factor (dB/m)	Cable Loss (dB)	Preamp Factor (dB)	Antenna Height (cm)	Table Angle (Degree)	Remark
5624.1	55.06	53.93	68.2	-13.14	31.79	6.56	37.22	148	350	Peak
5652.6	53.33	52.14	70.13	-16.8	31.85	6.62	37.28	148	350	Peak
5921.925	49.42	47.62	70.47	-21.05	32.29	7.01	37.5	148	350	Peak
5949.475	53.49	51.59	68.2	-14.71	32.32	7.08	37.5	148	350	Peak
Antenna Polarity & Test Distance: Vertical at 3 m										
Frequency (MHz)	Emission Level (dBuV/m)	Read Level (dBuV)	Limit (dBuV/m)	Margin (dB)	Antenna Factor (dB/m)	Cable Loss (dB)	Preamp Factor (dB)	Antenna Height (cm)	Table Angle (Degree)	Remark
5637.875	53.37	52.27	68.2	-14.83	31.82	6.56	37.28	222	42	Peak
5653.075	50.97	49.78	70.49	-19.52	31.85	6.62	37.28	222	42	Peak
5921.925	49.86	48.06	70.47	-20.61	32.29	7.01	37.5	222	42	Peak
6002.2	52.87	50.84	68.2	-15.33	32.4	7.14	37.51	222	42	Peak

Remarks:

- Emission Level = Read Level + Antenna Factor + Cable Loss - Preamp Factor  
Margin value = Emission level – Limit value
- 5745 MHz: Fundamental Frequency
- \*: Out of Restricted Band
- The other emission levels were very low against the limit.

EUT Test Condition		Measurement Detail	
Channel	Channel 157	Frequency Range	1 GHz ~ 40 GHz
Input Power	120 Vac, 60 Hz	Detector Function	Peak (PK) Average (AV)
Environmental Conditions	25 deg. C, 65 % RH	Tested By	Gavin Wu

### <Spurious Emission>

Antenna Polarity & Test Distance: Horizontal at 3 m										
Frequency (MHz)	Emission Level (dBuV/m)	Read Level (dBuV)	Limit (dBuV/m)	Margin (dB)	Antenna Factor (dB/m)	Cable Loss (dB)	Preamp Factor (dB)	Antenna Height (cm)	Table Angle (Degree)	Remark
5785	97.11	95.79			32.04	6.82	37.54	150	349	Average
5785	105.86	104.54			32.04	6.82	37.54	150	349	Peak
11570	47.05	49.52	54	-6.95	39.78	10.76	53.01	100	355	Average
11570	58.51	60.98	74	-15.49	39.78	10.76	53.01	100	355	Peak
Antenna Polarity & Test Distance: Vertical at 3 m										
Frequency (MHz)	Emission Level (dBuV/m)	Read Level (dBuV)	Limit (dBuV/m)	Margin (dB)	Antenna Factor (dB/m)	Cable Loss (dB)	Preamp Factor (dB)	Antenna Height (cm)	Table Angle (Degree)	Remark
5785	95.15	93.83			32.04	6.82	37.54	227	81	Average
5785	103.68	102.36			32.04	6.82	37.54	227	81	Peak
11570	47	49.47	54	-7	39.78	10.76	53.01	172	64	Average
11570	57.13	59.6	74	-16.87	39.78	10.76	53.01	172	64	Peak

### <Out of Band Emission (OOBE)>

Antenna Polarity & Test Distance: Horizontal at 3 m										
Frequency (MHz)	Emission Level (dBuV/m)	Read Level (dBuV)	Limit (dBuV/m)	Margin (dB)	Antenna Factor (dB/m)	Cable Loss (dB)	Preamp Factor (dB)	Antenna Height (cm)	Table Angle (Degree)	Remark
5635.5	54.95	53.85	68.2	-13.25	31.82	6.56	37.28	150	349	Peak
5651.65	53.73	52.54	69.43	-15.7	31.85	6.62	37.28	150	349	Peak
5921.45	52.95	51.18	70.82	-17.87	32.26	7.01	37.5	150	349	Peak
5959.45	53.07	51.15	68.2	-15.13	32.34	7.08	37.5	150	349	Peak
Antenna Polarity & Test Distance: Vertical at 3 m										
Frequency (MHz)	Emission Level (dBuV/m)	Read Level (dBuV)	Limit (dBuV/m)	Margin (dB)	Antenna Factor (dB/m)	Cable Loss (dB)	Preamp Factor (dB)	Antenna Height (cm)	Table Angle (Degree)	Remark
5639.3	53.91	52.81	68.2	-14.29	31.82	6.56	37.28	227	81	Peak
5653.075	52.75	51.56	70.49	-17.74	31.85	6.62	37.28	227	81	Peak
5921.925	51.6	49.8	70.47	-18.87	32.29	7.01	37.5	227	81	Peak
5984.15	52.55	50.55	68.2	-15.65	32.37	7.14	37.51	227	81	Peak

Remarks:

- Emission Level = Read Level + Antenna Factor + Cable Loss - Preamp Factor  
Margin value = Emission level – Limit value
- 5785 MHz: Fundamental Frequency
- \*: Out of Restricted Band
- The other emission levels were very low against the limit.

EUT Test Condition		Measurement Detail	
Channel	Channel 165	Frequency Range	1 GHz ~ 40 GHz
Input Power	120 Vac, 60 Hz	Detector Function	Peak (PK) Average (AV)
Environmental Conditions	25 deg. C, 65 % RH	Tested By	Gavin Wu

### <Spurious Emission>

Antenna Polarity & Test Distance: Horizontal at 3 m										
Frequency (MHz)	Emission Level (dBuV/m)	Read Level (dBuV)	Limit (dBuV/m)	Margin (dB)	Antenna Factor (dB/m)	Cable Loss (dB)	Preamp Factor (dB)	Antenna Height (cm)	Table Angle (Degree)	Remark
5825	97.08	95.61			32.12	6.88	37.53	135	348	Average
5825	105.93	104.46			32.12	6.88	37.53	135	348	Peak
11650	48.29	50.98	54	-5.71	39.65	10.8	53.14	102	59	Average
11650	59.44	62.13	74	-14.56	39.65	10.8	53.14	102	59	Peak
Antenna Polarity & Test Distance: Vertical at 3 m										
Frequency (MHz)	Emission Level (dBuV/m)	Read Level (dBuV)	Limit (dBuV/m)	Margin (dB)	Antenna Factor (dB/m)	Cable Loss (dB)	Preamp Factor (dB)	Antenna Height (cm)	Table Angle (Degree)	Remark
5825	95.05	93.58			32.12	6.88	37.53	226	67	Average
5825	104.08	102.61			32.12	6.88	37.53	226	67	Peak
11650	46.22	49.12	54	-7.78	39.65	10.8	53.35	152	249	Average
11650	56.63	59.53	74	-17.37	39.65	10.8	53.35	152	249	Peak

### <Out of Band Emission (OOBE)>

Antenna Polarity & Test Distance: Horizontal at 3 m										
Frequency (MHz)	Emission Level (dBuV/m)	Read Level (dBuV)	Limit (dBuV/m)	Margin (dB)	Antenna Factor (dB/m)	Cable Loss (dB)	Preamp Factor (dB)	Antenna Height (cm)	Table Angle (Degree)	Remark
5621.725	53.95	52.82	68.2	-14.25	31.79	6.56	37.22	135	348	Peak
5655.45	53.45	52.32	72.25	-18.8	31.85	6.62	37.34	135	348	Peak
5920.5	52.83	51.06	71.52	-18.69	32.26	7.01	37.5	135	348	Peak
5938.55	53.23	51.4	68.2	-14.97	32.32	7.01	37.5	135	348	Peak
Antenna Polarity & Test Distance: Vertical at 3 m										
Frequency (MHz)	Emission Level (dBuV/m)	Read Level (dBuV)	Limit (dBuV/m)	Margin (dB)	Antenna Factor (dB/m)	Cable Loss (dB)	Preamp Factor (dB)	Antenna Height (cm)	Table Angle (Degree)	Remark
5640.725	52.39	51.29	68.2	-15.81	31.82	6.56	37.28	226	67	Peak
5651.65	51.62	50.43	69.43	-17.81	31.85	6.62	37.28	226	67	Peak
5923.35	52.15	50.35	69.42	-17.27	32.29	7.01	37.5	226	67	Peak
5955.65	52.81	50.89	68.2	-15.39	32.34	7.08	37.5	226	67	Peak

Remarks:

- Emission Level = Read Level + Antenna Factor + Cable Loss - Preamp Factor  
Margin value = Emission level – Limit value
- 5825 MHz: Fundamental Frequency
- \*: Out of Restricted Band
- The other emission levels were very low against the limit.

### 802.11n (HT20)

EUT Test Condition		Measurement Detail	
Channel	Channel 36	Frequency Range	1 GHz ~ 40 GHz
Input Power	120 Vac, 60 Hz	Detector Function	Peak (PK) Average (AV)
Environmental Conditions	25 deg. C, 65 % RH	Tested By	Gavin Wu

#### Antenna Polarity & Test Distance: Horizontal at 3 m

Frequency (MHz)	Emission Level (dBuV/m)	Read Level (dBuV)	Limit (dBuV/m)	Margin (dB)	Antenna Factor (dB/m)	Cable Loss (dB)	Preamp Factor (dB)	Antenna Height (cm)	Table Angle (Degree)	Remark
5147.75	41.95	56.6	54	-12.05	31.32	7.04	53.01	130	4	Average
5147.75	56.27	55.93	74	-17.73	31.32	6.34	37.32	130	4	Peak
5180	89.5	89.12			31.35	6.37	37.34	130	4	Average
5180	104.28	103.9			31.35	6.37	37.34	130	4	Peak
*10360	56.14	59.19	68.2	-12.06	39.19	10.21	52.45	115	221	Peak

#### Antenna Polarity & Test Distance: Vertical at 3 m

Frequency (MHz)	Emission Level (dBuV/m)	Read Level (dBuV)	Limit (dBuV/m)	Margin (dB)	Antenna Factor (dB/m)	Cable Loss (dB)	Preamp Factor (dB)	Antenna Height (cm)	Table Angle (Degree)	Remark
5142.35	39.97	54.44	54	-14.03	31.32	7.03	52.82	205	59	Average
5142.35	52.85	52.5	74	-21.15	31.32	6.33	37.3	205	59	Peak
5180	93.29	92.91			31.35	6.37	37.34	205	59	Average
5180	102.08	101.7			31.35	6.37	37.34	205	59	Peak
*10360	56.82	59.56	68.2	-11.38	39.19	10.21	52.14	100	112	Peak

#### Remarks:

- Emission Level = Read Level + Antenna Factor + Cable Loss - Preamp Factor  
Margin value = Emission level – Limit value
- 5180 MHz: Fundamental Frequency
- \*: Out of Restricted Band
- The other emission levels were very low against the limit.

EUT Test Condition		Measurement Detail	
Channel	Channel 44	Frequency Range	1 GHz ~ 40 GHz
Input Power	120 Vac, 60 Hz	Detector Function	Peak (PK) Average (AV)
Environmental Conditions	25 deg. C, 65 % RH	Tested By	Gavin Wu

Antenna Polarity & Test Distance: Horizontal at 3 m										
Frequency (MHz)	Emission Level (dBuV/m)	Read Level (dBuV)	Limit (dBuV/m)	Margin (dB)	Antenna Factor (dB/m)	Cable Loss (dB)	Preamp Factor (dB)	Antenna Height (cm)	Table Angle (Degree)	Remark
5120.15	40.78	55.51	54	-13.22	31.29	7.01	53.03	139	4	Average
5120.15	53.6	53.3	74	-20.4	31.29	6.31	37.3	139	4	Peak
5220	95.28	94.87			31.37	6.4	37.36	139	4	Average
5220	104.12	103.71			31.37	6.4	37.36	139	4	Peak
5353.96	39.34	53.51	54	-14.66	31.48	7.18	52.83	139	4	Average
5353.96	51.73	50.96	74	-22.27	31.48	6.47	37.18	139	4	Peak
*10440	54.57	57.59	68.2	-13.63	39.29	10.21	52.52	116	241	Peak
Antenna Polarity & Test Distance: Vertical at 3 m										
Frequency (MHz)	Emission Level (dBuV/m)	Read Level (dBuV)	Limit (dBuV/m)	Margin (dB)	Antenna Factor (dB/m)	Cable Loss (dB)	Preamp Factor (dB)	Antenna Height (cm)	Table Angle (Degree)	Remark
5013.95	39.2	54.12	54	-14.8	31.21	6.92	53.05	225	55	Average
5013.95	51.05	50.85	74	-22.95	31.21	6.22	37.23	225	55	Peak
5220	93.79	93.38			31.37	6.4	37.36	225	55	Average
5220	102.63	102.22			31.37	6.4	37.36	225	55	Peak
5372.77	38.92	52.99	54	-15.08	31.49	7.18	52.74	225	55	Average
5372.77	51.1	50.32	74	-22.9	31.49	6.47	37.18	225	55	Peak
*10440	53.69	56.67	68.2	-14.51	39.29	10.21	52.48	100	54	Peak

Remarks:

- Emission Level = Read Level + Antenna Factor + Cable Loss - Preamp Factor  
Margin value = Emission level – Limit value
- 5220 MHz: Fundamental Frequency
- \*: Out of Restricted Band
- The other emission levels were very low against the limit.

EUT Test Condition		Measurement Detail	
Channel	Channel 48	Frequency Range	1 GHz ~ 40 GHz
Input Power	120 Vac, 60 Hz	Detector Function	Peak (PK) Average (AV)
Environmental Conditions	25 deg. C, 65 % RH	Tested By	Gavin Wu

Antenna Polarity & Test Distance: Horizontal at 3 m										
Frequency (MHz)	Emission Level (dBuV/m)	Read Level (dBuV)	Limit (dBuV/m)	Margin (dB)	Antenna Factor (dB/m)	Cable Loss (dB)	Preamp Factor (dB)	Antenna Height (cm)	Table Angle (Degree)	Remark
5139.35	40.56	55.25	54	-13.44	31.31	7.03	53.03	135	2	Average
5139.35	53.12	52.78	74	-20.88	31.31	6.33	37.3	135	2	Peak
5240	95.54	95.05			31.39	6.42	37.32	135	2	Average
5240	104.49	104			31.39	6.42	37.32	135	2	Peak
5393.01	39.57	53.67	54	-14.43	31.51	7.17	52.78	135	2	Average
5393.01	51.77	50.97	74	-22.23	31.51	6.47	37.18	135	2	Peak
*10480	55.02	58.09	68.2	-13.18	39.37	10.22	52.66	116	238	Peak
Antenna Polarity & Test Distance: Vertical at 3 m										
Frequency (MHz)	Emission Level (dBuV/m)	Read Level (dBuV)	Limit (dBuV/m)	Margin (dB)	Antenna Factor (dB/m)	Cable Loss (dB)	Preamp Factor (dB)	Antenna Height (cm)	Table Angle (Degree)	Remark
5133.05	39.16	53.65	54	-14.84	31.31	7.02	52.82	224	54	Average
5133.05	50.83	50.5	74	-23.17	31.31	6.32	37.3	224	54	Peak
5240	93.79	93.3			31.39	6.42	37.32	224	54	Average
5240	102.33	101.84			31.39	6.42	37.32	224	54	Peak
5405.11	38.96	52.97	54	-15.04	31.52	7.17	52.7	224	54	Average
5405.11	51.39	50.58	74	-22.61	31.52	6.47	37.18	224	54	Peak
*10480	54.86	57.98	68.2	-13.34	39.37	10.22	52.71	101	77	Peak

Remarks:

- Emission Level = Read Level + Antenna Factor + Cable Loss - Preamp Factor  
Margin value = Emission level – Limit value
- 5240 MHz: Fundamental Frequency
- \*: Out of Restricted Band
- The other emission levels were very low against the limit.



EUT Test Condition		Measurement Detail	
Channel	Channel 149	Frequency Range	1 GHz ~ 40 GHz
Input Power	120 Vac, 60 Hz	Detector Function	Peak (PK) Average (AV)
Environmental Conditions	25 deg. C, 65 % RH	Tested By	Gavin Wu

### <Spurious Emission>

Antenna Polarity & Test Distance: Horizontal at 3 m										
Frequency (MHz)	Emission Level (dBuV/m)	Read Level (dBuV)	Limit (dBuV/m)	Margin (dB)	Antenna Factor (dB/m)	Cable Loss (dB)	Preamp Factor (dB)	Antenna Height (cm)	Table Angle (Degree)	Remark
5745	95.53	94.26			31.99	6.75	37.47	149	346	Average
5745	104.77	103.5			31.99	6.75	37.47	149	346	Peak
11490	47.9	50.11	54	-6.1	39.91	10.66	52.78	154	265	Average
11490	55.48	57.69	74	-18.52	39.91	10.66	52.78	154	265	Peak
Antenna Polarity & Test Distance: Vertical at 3 m										
Frequency (MHz)	Emission Level (dBuV/m)	Read Level (dBuV)	Limit (dBuV/m)	Margin (dB)	Antenna Factor (dB/m)	Cable Loss (dB)	Preamp Factor (dB)	Antenna Height (cm)	Table Angle (Degree)	Remark
5745	93.41	92.14			31.99	6.75	37.47	221	84	Average
5745	102.36	101.09			31.99	6.75	37.47	221	84	Peak
11490	46.52	48.78	54	-7.48	39.91	10.66	52.83	144	261	Average
11490	56.95	59.21	74	-17.05	39.91	10.66	52.83	144	261	Peak

### <Out of Band Emission (OOBE)>

Antenna Polarity & Test Distance: Horizontal at 3 m										
Frequency (MHz)	Emission Level (dBuV/m)	Read Level (dBuV)	Limit (dBuV/m)	Margin (dB)	Antenna Factor (dB/m)	Cable Loss (dB)	Preamp Factor (dB)	Antenna Height (cm)	Table Angle (Degree)	Remark
5594.175	54.33	53.26	68.2	-13.87	31.74	6.49	37.16	149	346	Peak
5653.075	51.6	50.41	70.49	-18.89	31.85	6.62	37.28	149	346	Peak
5921.925	50.67	48.87	70.47	-19.8	32.29	7.01	37.5	149	346	Peak
5994.125	52.99	50.96	68.2	-15.21	32.4	7.14	37.51	149	346	Peak
Antenna Polarity & Test Distance: Vertical at 3 m										
Frequency (MHz)	Emission Level (dBuV/m)	Read Level (dBuV)	Limit (dBuV/m)	Margin (dB)	Antenna Factor (dB/m)	Cable Loss (dB)	Preamp Factor (dB)	Antenna Height (cm)	Table Angle (Degree)	Remark
5625.525	53.88	52.75	68.2	-14.32	31.79	6.56	37.22	221	84	Peak
5652.6	52.47	51.28	70.13	-17.66	31.85	6.62	37.28	221	84	Peak
5921.45	50.17	48.4	70.82	-20.65	32.26	7.01	37.5	221	84	Peak
5982.725	52.32	50.38	68.2	-15.88	32.37	7.08	37.51	221	84	Peak

Remarks:

- Emission Level = Read Level + Antenna Factor + Cable Loss - Preamp Factor  
Margin value = Emission level – Limit value
- 5745 MHz: Fundamental Frequency
- \*: Out of Restricted Band
- The other emission levels were very low against the limit.

EUT Test Condition		Measurement Detail	
Channel	Channel 157	Frequency Range	1 GHz ~ 40 GHz
Input Power	120 Vac, 60 Hz	Detector Function	Peak (PK) Average (AV)
Environmental Conditions	25 deg. C, 65 % RH	Tested By	Gavin Wu

### <Spurious Emission>

Antenna Polarity & Test Distance: Horizontal at 3 m										
Frequency (MHz)	Emission Level (dBuV/m)	Read Level (dBuV)	Limit (dBuV/m)	Margin (dB)	Antenna Factor (dB/m)	Cable Loss (dB)	Preamp Factor (dB)	Antenna Height (cm)	Table Angle (Degree)	Remark
5785	95.64	94.32			32.04	6.82	37.54	147	349	Average
5785	104.27	102.95			32.04	6.82	37.54	147	349	Peak
11570	47.42	49.89	54	-6.58	39.78	10.76	53.01	101	164	Average
11570	54.72	57.19	74	-19.28	39.78	10.76	53.01	101	164	Peak
Antenna Polarity & Test Distance: Vertical at 3 m										
Frequency (MHz)	Emission Level (dBuV/m)	Read Level (dBuV)	Limit (dBuV/m)	Margin (dB)	Antenna Factor (dB/m)	Cable Loss (dB)	Preamp Factor (dB)	Antenna Height (cm)	Table Angle (Degree)	Remark
5785	93.5	92.18			32.04	6.82	37.54	222	82	Average
5785	102.2	100.88			32.04	6.82	37.54	222	82	Peak
11570	46.01	48.8	54	-7.99	39.78	10.76	53.33	147	258	Average
11570	54.44	57.23	74	-19.56	39.78	10.76	53.33	147	258	Peak

### <Out of Band Emission (OOBE)>

Antenna Polarity & Test Distance: Horizontal at 3 m										
Frequency (MHz)	Emission Level (dBuV/m)	Read Level (dBuV)	Limit (dBuV/m)	Margin (dB)	Antenna Factor (dB/m)	Cable Loss (dB)	Preamp Factor (dB)	Antenna Height (cm)	Table Angle (Degree)	Remark
5605.1	55.08	53.97	68.2	-13.12	31.77	6.56	37.22	147	349	Peak
5653.075	53.17	51.98	70.49	-17.32	31.85	6.62	37.28	147	349	Peak
5921.925	50.71	48.91	70.47	-19.76	32.29	7.01	37.5	147	349	Peak
5938.075	53.16	51.36	68.2	-15.04	32.29	7.01	37.5	147	349	Peak
Antenna Polarity & Test Distance: Vertical at 3 m										
Frequency (MHz)	Emission Level (dBuV/m)	Read Level (dBuV)	Limit (dBuV/m)	Margin (dB)	Antenna Factor (dB/m)	Cable Loss (dB)	Preamp Factor (dB)	Antenna Height (cm)	Table Angle (Degree)	Remark
5643.1	54	52.84	68.2	-14.2	31.82	6.62	37.28	222	82	Peak
5653.075	50.95	49.76	70.49	-19.54	31.85	6.62	37.28	222	82	Peak
5922.875	51.15	49.35	69.77	-18.62	32.29	7.01	37.5	222	82	Peak
5992.225	52.35	50.32	68.2	-15.85	32.4	7.14	37.51	222	82	Peak

Remarks:

- Emission Level = Read Level + Antenna Factor + Cable Loss - Preamp Factor  
Margin value = Emission level – Limit value
- 5785 MHz: Fundamental Frequency
- \*: Out of Restricted Band
- The other emission levels were very low against the limit.

EUT Test Condition		Measurement Detail	
Channel	Channel 165	Frequency Range	1 GHz ~ 40 GHz
Input Power	120 Vac, 60 Hz	Detector Function	Peak (PK) Average (AV)
Environmental Conditions	25 deg. C, 65 % RH	Tested By	Gavin Wu

### <Spurious Emission>

Antenna Polarity & Test Distance: Horizontal at 3 m										
Frequency (MHz)	Emission Level (dBuV/m)	Read Level (dBuV)	Limit (dBuV/m)	Margin (dB)	Antenna Factor (dB/m)	Cable Loss (dB)	Preamp Factor (dB)	Antenna Height (cm)	Table Angle (Degree)	Remark
5825	96.22	94.75			32.12	6.88	37.53	115	348	Average
5825	104.85	103.38			32.12	6.88	37.53	115	348	Peak
11653	46.93	49.65	54	-7.07	39.62	10.8	53.14	100	165	Average
11653	55.39	58.11	74	-18.61	39.62	10.8	53.14	100	165	Peak
Antenna Polarity & Test Distance: Vertical at 3 m										
Frequency (MHz)	Emission Level (dBuV/m)	Read Level (dBuV)	Limit (dBuV/m)	Margin (dB)	Antenna Factor (dB/m)	Cable Loss (dB)	Preamp Factor (dB)	Antenna Height (cm)	Table Angle (Degree)	Remark
5825	92.76	91.29			32.12	6.88	37.53	219	92	Average
5825	102.09	100.62			32.12	6.88	37.53	219	92	Peak
11650	45.94	48.84	54	-8.06	39.65	10.8	53.35	124	255	Average
11650	54.09	56.99	74	-19.91	39.65	10.8	53.35	124	255	Peak

### <Out of Band Emission (OOBE)>

Antenna Polarity & Test Distance: Horizontal at 3 m										
Frequency (MHz)	Emission Level (dBuV/m)	Read Level (dBuV)	Limit (dBuV/m)	Margin (dB)	Antenna Factor (dB/m)	Cable Loss (dB)	Preamp Factor (dB)	Antenna Height (cm)	Table Angle (Degree)	Remark
5639.775	54.02	52.92	68.2	-14.18	31.82	6.56	37.28	115	348	Peak
5652.6	52.74	51.55	70.13	-17.39	31.85	6.62	37.28	115	348	Peak
5922.4	51.11	49.31	70.12	-19.01	32.29	7.01	37.5	115	348	Peak
5974.175	53.08	51.14	68.2	-15.12	32.37	7.08	37.51	115	348	Peak
Antenna Polarity & Test Distance: Vertical at 3 m										
Frequency (MHz)	Emission Level (dBuV/m)	Read Level (dBuV)	Limit (dBuV/m)	Margin (dB)	Antenna Factor (dB/m)	Cable Loss (dB)	Preamp Factor (dB)	Antenna Height (cm)	Table Angle (Degree)	Remark
5640.725	53.14	52.04	68.2	-15.06	31.82	6.56	37.28	219	92	Peak
5652.6	50.39	49.2	70.13	-19.74	31.85	6.62	37.28	219	92	Peak
5921.45	51.23	49.46	70.82	-19.59	32.26	7.01	37.5	219	92	Peak
5958.975	52.8	50.88	68.2	-15.4	32.34	7.08	37.5	219	92	Peak

Remarks:

- Emission Level = Read Level + Antenna Factor + Cable Loss - Preamp Factor  
Margin value = Emission level – Limit value
- 5825 MHz: Fundamental Frequency
- \*: Out of Restricted Band
- The other emission levels were very low against the limit.

### 802.11n (HT40)

EUT Test Condition		Measurement Detail	
Channel	Channel 38	Frequency Range	1 GHz ~ 40 GHz
Input Power	120 Vac, 60 Hz	Detector Function	Peak (PK) Average (AV)
Environmental Conditions	25 deg. C, 65 % RH	Tested By	Gavin Wu

#### Antenna Polarity & Test Distance: Horizontal at 3 m

Frequency (MHz)	Emission Level (dBUV/m)	Read Level (dBUV)	Limit (dBUV/m)	Margin (dB)	Antenna Factor (dB/m)	Cable Loss (dB)	Preamp Factor (dB)	Antenna Height (cm)	Table Angle (Degree)	Remark
5148.8	52.61	67.26	54	-1.39	31.32	7.04	53.01	109	5	Average
5148.8	64.87	64.53	74	-9.13	31.32	6.34	37.32	109	5	Peak
5190	96.32	95.93			31.35	6.38	37.34	109	5	Average
5190	104.89	104.5			31.35	6.38	37.34	109	5	Peak
5372.55	39.82	53.98	54	-14.18	31.49	7.18	52.83	109	5	Average
5372.55	51.21	50.43	74	-22.79	31.49	6.47	37.18	109	5	Peak
*10380	54.25	57.28	68.2	-13.95	39.21	10.21	52.45	112	256	Peak

#### Antenna Polarity & Test Distance: Vertical at 3 m

Frequency (MHz)	Emission Level (dBUV/m)	Read Level (dBUV)	Limit (dBUV/m)	Margin (dB)	Antenna Factor (dB/m)	Cable Loss (dB)	Preamp Factor (dB)	Antenna Height (cm)	Table Angle (Degree)	Remark
5149.25	48.14	47.8	54	-5.86	31.32	6.34	37.32	227	58	Average
5149.25	64.71	64.37	74	-9.29	31.32	6.34	37.32	227	58	Peak
5190	93.12	92.73			31.35	6.38	37.34	227	58	Average
5190	101.41	101.02			31.35	6.38	37.34	227	58	Peak
5457.69	39.56	53.27	54	-14.44	31.56	7.22	52.49	227	58	Average
5457.69	51.37	50.38	74	-22.63	31.56	6.51	37.08	227	58	Peak
*10380	56.6	59.43	68.2	-11.6	39.21	10.21	52.25	102	59	Peak

#### Remarks:

- Emission Level = Read Level + Antenna Factor + Cable Loss - Preamp Factor  
Margin value = Emission level – Limit value
- 5190 MHz: Fundamental Frequency
- \*: Out of Restricted Band
- The other emission levels were very low against the limit.

EUT Test Condition		Measurement Detail	
Channel	Channel 46	Frequency Range	1 GHz ~ 40 GHz
Input Power	120 Vac, 60 Hz	Detector Function	Peak (PK) Average (AV)
Environmental Conditions	25 deg. C, 65 % RH	Tested By	Gavin Wu

Antenna Polarity & Test Distance: Horizontal at 3 m										
Frequency (MHz)	Emission Level (dBuV/m)	Read Level (dBuV)	Limit (dBuV/m)	Margin (dB)	Antenna Factor (dB/m)	Cable Loss (dB)	Preamp Factor (dB)	Antenna Height (cm)	Table Angle (Degree)	Remark
5134.25	41.57	56.27	54	-12.43	31.31	7.02	53.03	118	5	Average
5134.25	53.42	53.09	74	-20.58	31.31	6.32	37.3	118	5	Peak
5230	94.98	94.5			31.39	6.41	37.32	118	5	Average
5230	103.78	103.3			31.39	6.41	37.32	118	5	Peak
5362.87	39.89	54.05	54	-14.11	31.49	7.18	52.83	118	5	Average
5362.87	51.31	50.53	74	-22.69	31.49	6.47	37.18	118	5	Peak
10460	54.82	57.87	68.2	-13.38	39.32	10.22	52.59	118	271	Peak
Antenna Polarity & Test Distance: Vertical at 3 m										
Frequency (MHz)	Emission Level (dBuV/m)	Read Level (dBuV)	Limit (dBuV/m)	Margin (dB)	Antenna Factor (dB/m)	Cable Loss (dB)	Preamp Factor (dB)	Antenna Height (cm)	Table Angle (Degree)	Remark
5118.5	40.1	54.62	54	-13.9	31.29	7.01	52.82	220	59	Average
5118.5	51.64	51.34	74	-22.36	31.29	6.31	37.3	220	59	Peak
5230	92.71	92.23			31.39	6.41	37.32	220	59	Average
5230	101.42	100.94			31.39	6.41	37.32	220	59	Peak
5379.59	39.66	53.7	54	-14.34	31.51	7.17	52.72	220	59	Average
5379.59	51.29	50.49	74	-22.71	31.51	6.47	37.18	220	59	Peak
10460	55.42	58.48	68.2	-12.78	39.32	10.22	52.6	100	49	Peak

Remarks:

- Emission Level = Read Level + Antenna Factor + Cable Loss - Preamp Factor  
Margin value = Emission level – Limit value
- 5230 MHz: Fundamental Frequency
- \*: Out of Restricted Band
- The other emission levels were very low against the limit.

EUT Test Condition		Measurement Detail	
Channel	Channel 151	Frequency Range	1 GHz ~ 40 GHz
Input Power	120 Vac, 60 Hz	Detector Function	Peak (PK) Average (AV)
Environmental Conditions	25 deg. C, 65 % RH	Tested By	Gavin Wu

### <Spurious Emission>

Antenna Polarity & Test Distance: Horizontal at 3 m										
Frequency (MHz)	Emission Level (dBuV/m)	Read Level (dBuV)	Limit (dBuV/m)	Margin (dB)	Antenna Factor (dB/m)	Cable Loss (dB)	Preamp Factor (dB)	Antenna Height (cm)	Table Angle (Degree)	Remark
5755	96.55	95.26			32.01	6.75	37.47	134	350	Average
5755	104.73	103.44			32.01	6.75	37.47	134	350	Peak
11510	47.53	49.75	54	-6.47	39.9	10.69	52.81	100	174	Average
11510	55.85	58.07	74	-18.15	39.9	10.69	52.81	100	174	Peak
Antenna Polarity & Test Distance: Vertical at 3 m										
Frequency (MHz)	Emission Level (dBuV/m)	Read Level (dBuV)	Limit (dBuV/m)	Margin (dB)	Antenna Factor (dB/m)	Cable Loss (dB)	Preamp Factor (dB)	Antenna Height (cm)	Table Angle (Degree)	Remark
5755	94.92	93.63			32.01	6.75	37.47	221	96	Average
5755	103.74	102.45			32.01	6.75	37.47	221	96	Peak
11510	46.27	48.75	54	-7.73	39.9	10.69	53.07	114	254	Average
11510	56.25	58.73	74	-17.75	39.9	10.69	53.07	114	254	Peak

### <Out of Band Emission (OOBE)>

Antenna Polarity & Test Distance: Horizontal at 3 m										
Frequency (MHz)	Emission Level (dBuV/m)	Read Level (dBuV)	Limit (dBuV/m)	Margin (dB)	Antenna Factor (dB/m)	Cable Loss (dB)	Preamp Factor (dB)	Antenna Height (cm)	Table Angle (Degree)	Remark
5627.425	55.58	54.45	68.2	-12.62	31.79	6.56	37.22	134	350	Peak
5652.125	53.33	52.14	69.78	-16.45	31.85	6.62	37.28	134	350	Peak
5923.35	50.85	49.05	69.42	-18.57	32.29	7.01	37.5	134	350	Peak
5996.5	52.82	50.79	68.2	-15.38	32.4	7.14	37.51	134	350	Peak
Antenna Polarity & Test Distance: Vertical at 3 m										
Frequency (MHz)	Emission Level (dBuV/m)	Read Level (dBuV)	Limit (dBuV/m)	Margin (dB)	Antenna Factor (dB/m)	Cable Loss (dB)	Preamp Factor (dB)	Antenna Height (cm)	Table Angle (Degree)	Remark
5594.175	55.01	53.94	68.2	-13.19	31.74	6.49	37.16	221	96	Peak
5652.125	52.35	51.16	69.78	-17.43	31.85	6.62	37.28	221	96	Peak
5921.925	50.17	48.37	70.47	-20.3	32.29	7.01	37.5	221	96	Peak
5964.2	52.03	50.12	68.2	-16.17	32.34	7.08	37.51	221	96	Peak

Remarks:

- Emission Level = Read Level + Antenna Factor + Cable Loss - Preamp Factor  
Margin value = Emission level – Limit value
- 5755 MHz: Fundamental Frequency
- \*: Out of Restricted Band
- The other emission levels were very low against the limit.

EUT Test Condition		Measurement Detail	
Channel	Channel 159	Frequency Range	1 GHz ~ 40 GHz
Input Power	120 Vac, 60 Hz	Detector Function	Peak (PK) Average (AV)
Environmental Conditions	25 deg. C, 65 % RH	Tested By	Gavin Wu

### <Spurious Emission>

Antenna Polarity & Test Distance: Horizontal at 3 m										
Frequency (MHz)	Emission Level (dBuV/m)	Read Level (dBuV)	Limit (dBuV/m)	Margin (dB)	Antenna Factor (dB/m)	Cable Loss (dB)	Preamp Factor (dB)	Antenna Height (cm)	Table Angle (Degree)	Remark
5795	96.15	94.8			32.07	6.82	37.54	130	348	Average
5795	104.79	103.44			32.07	6.82	37.54	130	348	Peak
11590	46.74	49.23	54	-7.26	39.74	10.78	53.01	100	334	Average
11590	54.54	57.03	74	-19.46	39.74	10.78	53.01	100	334	Peak
Antenna Polarity & Test Distance: Vertical at 3 m										
Frequency (MHz)	Emission Level (dBuV/m)	Read Level (dBuV)	Limit (dBuV/m)	Margin (dB)	Antenna Factor (dB/m)	Cable Loss (dB)	Preamp Factor (dB)	Antenna Height (cm)	Table Angle (Degree)	Remark
5795	93.55	92.2			32.07	6.82	37.54	221	93	Average
5795	102.46	101.11			32.07	6.82	37.54	221	93	Peak
11590	46.25	48.74	54	-7.75	39.74	10.78	53.01	137	298	Average
11590	54.75	57.24	74	-19.25	39.74	10.78	53.01	137	298	Peak

### <Out of Band Emission (OOBE)>

Antenna Polarity & Test Distance: Horizontal at 3 m										
Frequency (MHz)	Emission Level (dBuV/m)	Read Level (dBuV)	Limit (dBuV/m)	Margin (dB)	Antenna Factor (dB/m)	Cable Loss (dB)	Preamp Factor (dB)	Antenna Height (cm)	Table Angle (Degree)	Remark
5612.7	54.83	53.72	68.2	-13.37	31.77	6.56	37.22	130	348	Peak
5652.6	53.74	52.55	70.13	-16.39	31.85	6.62	37.28	130	348	Peak
5921.925	49.78	47.98	70.47	-20.69	32.29	7.01	37.5	130	348	Peak
5928.1	52.59	50.79	68.2	-15.61	32.29	7.01	37.5	130	348	Peak
Antenna Polarity & Test Distance: Vertical at 3 m										
Frequency (MHz)	Emission Level (dBuV/m)	Read Level (dBuV)	Limit (dBuV/m)	Margin (dB)	Antenna Factor (dB/m)	Cable Loss (dB)	Preamp Factor (dB)	Antenna Height (cm)	Table Angle (Degree)	Remark
5636.45	54.23	53.13	68.2	-13.97	31.82	6.56	37.28	221	93	Peak
5652.6	52.92	51.73	70.13	-17.21	31.85	6.62	37.28	221	93	Peak
5923.825	52.62	50.82	69.07	-16.45	32.29	7.01	37.5	221	93	Peak
5955.175	52.44	50.54	68.2	-15.76	32.32	7.08	37.5	221	93	Peak

Remarks:

- Emission Level = Read Level + Antenna Factor + Cable Loss - Preamp Factor  
Margin value = Emission level – Limit value
- 5795 MHz: Fundamental Frequency
- \*: Out of Restricted Band
- The other emission levels were very low against the limit.

**Mode B**  
**802.11a**

EUT Test Condition		Measurement Detail	
Channel	Channel 36	Frequency Range	1 GHz ~ 40 GHz
Input Power	120 Vac, 60 Hz	Detector Function	Peak (PK) Average (AV)
Environmental Conditions	25 deg. C, 65 % RH	Tested By	Thomas Wei

Antenna Polarity & Test Distance: Horizontal at 3 m										
Frequency (MHz)	Emission Level (dBuV/m)	Read Level (dBuV)	Limit (dBuV/m)	Margin (dB)	Antenna Factor (dB/m)	Cable Loss (dB)	Preamp Factor (dB)	Antenna Height (cm)	Table Angle (Degree)	Remark
5150	45.08	44.5	54	-8.92	31.56	6.34	37.32	113	117	Average
5150	60.67	60.09	74	-13.33	31.56	6.34	37.32	113	117	Peak
5180	98.96	98.34			31.59	6.37	37.34	113	117	Average
5180	107.65	107.03			31.59	6.37	37.34	113	117	Peak
*10360	56.1	58.86	68.2	-12.1	39.48	10.21	52.45	141	203	Peak

Antenna Polarity & Test Distance: Vertical at 3 m										
Frequency (MHz)	Emission Level (dBuV/m)	Read Level (dBuV)	Limit (dBuV/m)	Margin (dB)	Antenna Factor (dB/m)	Cable Loss (dB)	Preamp Factor (dB)	Antenna Height (cm)	Table Angle (Degree)	Remark
5150	39.7	39.12	54	-14.3	31.56	6.34	37.32	222	20	Average
5150	51.92	51.34	74	-22.08	31.56	6.34	37.32	222	20	Peak
5180	90.53	89.91			31.59	6.37	37.34	222	20	Average
5180	100.18	99.56			31.59	6.37	37.34	222	20	Peak
*10360	56.36	59.12	68.2	-11.84	39.48	10.21	52.45	129	255	Peak

Remarks:

- Emission Level = Read Level + Antenna Factor + Cable Loss - Preamp Factor  
Margin value = Emission level – Limit value
- 5180 MHz: Fundamental Frequency
- \*: Out of Restricted Band
- The other emission levels were very low against the limit.



EUT Test Condition		Measurement Detail	
Channel	Channel 40	Frequency Range	1 GHz ~ 40 GHz
Input Power	120 Vac, 60 Hz	Detector Function	Peak (PK) Average (AV)
Environmental Conditions	25 deg. C, 65 % RH	Tested By	Thomas Wei

Antenna Polarity & Test Distance: Horizontal at 3 m										
Frequency (MHz)	Emission Level (dBuV/m)	Read Level (dBuV)	Limit (dBuV/m)	Margin (dB)	Antenna Factor (dB/m)	Cable Loss (dB)	Preamp Factor (dB)	Antenna Height (cm)	Table Angle (Degree)	Remark
5149.94	43.39	5.48	54	-10.61	31.57	6.34	0	111	114	Average
5149.94	54.77	54.19	74	-19.23	31.56	6.34	37.32	111	114	Peak
5200	99.09	98.46			31.6	6.39	37.36	111	114	Average
5200	108.49	107.86			31.6	6.39	37.36	111	114	Peak
5350.11	38.85	37.86	54	-15.15	31.7	6.47	37.18	111	114	Average
5350.11	51.78	50.79	74	-22.22	31.7	6.47	37.18	111	114	Peak
*10400	54.33	57.07	68.2	-13.87	39.51	10.2	52.45	147	139	Peak
Antenna Polarity & Test Distance: Vertical at 3 m										
Frequency (MHz)	Emission Level (dBuV/m)	Read Level (dBuV)	Limit (dBuV/m)	Margin (dB)	Antenna Factor (dB/m)	Cable Loss (dB)	Preamp Factor (dB)	Antenna Height (cm)	Table Angle (Degree)	Remark
5149.22	39.57	38.99	54	-14.43	31.56	6.34	37.32	268	33	Average
5149.22	52.04	51.46	74	-21.96	31.56	6.34	37.32	268	33	Peak
5200	89.64	89.01			31.6	6.39	37.36	268	33	Average
5200	100.34	99.71			31.6	6.39	37.36	268	33	Peak
5442.29	38.19	37.06	54	-15.81	31.76	6.5	37.13	268	33	Average
5442.29	50.58	49.45	74	-23.42	31.76	6.5	37.13	268	33	Peak
*10400	54	56.74	68.2	-14.2	39.51	10.2	52.45	161	197	Peak

Remarks:

- Emission Level = Read Level + Antenna Factor + Cable Loss - Preamp Factor  
Margin value = Emission level – Limit value
- 5200 MHz: Fundamental Frequency
- \*: Out of Restricted Band
- The other emission levels were very low against the limit.

EUT Test Condition		Measurement Detail	
Channel	Channel 48	Frequency Range	1 GHz ~ 40 GHz
Input Power	120 Vac, 60 Hz	Detector Function	Peak (PK) Average (AV)
Environmental Conditions	25 deg. C, 65 % RH	Tested By	Thomas Wei

Antenna Polarity & Test Distance: Horizontal at 3 m										
Frequency (MHz)	Emission Level (dBuV/m)	Read Level (dBuV)	Limit (dBuV/m)	Margin (dB)	Antenna Factor (dB/m)	Cable Loss (dB)	Preamp Factor (dB)	Antenna Height (cm)	Table Angle (Degree)	Remark
5149.94	41.5	40.92	54	-12.5	31.56	6.34	37.32	148	131	Average
5149.94	53.5	52.92	74	-20.5	31.56	6.34	37.32	148	131	Peak
5240	98.7	97.98			31.62	6.42	37.32	148	131	Average
5240	107.8	107.08			31.62	6.42	37.32	148	131	Peak
5360.56	40.12	39.11	54	-13.88	31.72	6.47	37.18	148	131	Average
5360.56	53	51.99	74	-21	31.72	6.47	37.18	148	131	Peak
*10480	53.79	56.63	68.2	-14.41	39.6	10.22	52.66	139	94	Peak
Antenna Polarity & Test Distance: Vertical at 3 m										
Frequency (MHz)	Emission Level (dBuV/m)	Read Level (dBuV)	Limit (dBuV/m)	Margin (dB)	Antenna Factor (dB/m)	Cable Loss (dB)	Preamp Factor (dB)	Antenna Height (cm)	Table Angle (Degree)	Remark
5133.56	38.61	38.04	54	-15.39	31.55	6.32	37.3	225	19	Average
5133.56	51.56	50.99	74	-22.44	31.55	6.32	37.3	225	19	Peak
5240	91.42	90.7			31.62	6.42	37.32	225	19	Average
5240	101.06	100.34			31.62	6.42	37.32	225	19	Peak
5442.18	38.21	37.08	54	-15.79	31.76	6.5	37.13	225	19	Average
5442.18	51.53	50.4	74	-22.47	31.76	6.5	37.13	225	19	Peak
*10480	54.5	57.34	68.2	-13.7	39.6	10.22	52.66	164	77	Peak

Remarks:

- Emission Level = Read Level + Antenna Factor + Cable Loss - Preamp Factor  
Margin value = Emission level – Limit value
- 5240 MHz: Fundamental Frequency
- \*: Out of Restricted Band
- The other emission levels were very low against the limit.

EUT Test Condition		Measurement Detail	
Channel	Channel 149	Frequency Range	1 GHz ~ 40 GHz
Input Power	120 Vac, 60 Hz	Detector Function	Peak (PK) Average (AV)
Environmental Conditions	25 deg. C, 65 % RH	Tested By	Jisyong Wang

### <Spurious Emission>

Antenna Polarity & Test Distance: Horizontal at 3 m										
Frequency (MHz)	Emission Level (dBuV/m)	Read Level (dBuV)	Limit (dBuV/m)	Margin (dB)	Antenna Factor (dB/m)	Cable Loss (dB)	Preamp Factor (dB)	Antenna Height (cm)	Table Angle (Degree)	Remark
5745	95.59	94.07			32.21	6.78	37.47	117	327	Average
5745	105.67	104.15			32.21	6.78	37.47	117	327	Peak
11490	47.64	49.51	54	-6.36	40.25	10.66	52.78	152	111	Average
11490	57.55	59.42	74	-16.45	40.25	10.66	52.78	152	111	Peak
Antenna Polarity & Test Distance: Vertical at 3 m										
Frequency (MHz)	Emission Level (dBuV/m)	Read Level (dBuV)	Limit (dBuV/m)	Margin (dB)	Antenna Factor (dB/m)	Cable Loss (dB)	Preamp Factor (dB)	Antenna Height (cm)	Table Angle (Degree)	Remark
5745	86.79	85.27			32.21	6.78	37.47	274	59	Average
5745	96.86	95.34			32.21	6.78	37.47	274	59	Peak
11490	47.48	49.35	54	-6.52	40.25	10.66	52.78	165	231	Average
11490	57.49	59.36	74	-16.51	40.25	10.66	52.78	165	231	Peak

### <Out of Band Emission (OOBE)>

Antenna Polarity & Test Distance: Horizontal at 3 m										
Frequency (MHz)	Emission Level (dBuV/m)	Read Level (dBuV)	Limit (dBuV/m)	Margin (dB)	Antenna Factor (dB/m)	Cable Loss (dB)	Preamp Factor (dB)	Antenna Height (cm)	Table Angle (Degree)	Remark
5557.6	51.91	50.52	68.2	-16.29	31.89	6.62	37.12	117	327	Peak
5653.075	52.27	50.78	70.49	-18.22	32.06	6.71	37.28	117	327	Peak
5920.975	51.37	49.52	71.17	-19.8	32.49	6.86	37.5	117	327	Peak
5968.95	52.66	50.72	68.2	-15.54	32.57	6.88	37.51	117	327	Peak
Antenna Polarity & Test Distance: Vertical at 3 m										
Frequency (MHz)	Emission Level (dBuV/m)	Read Level (dBuV)	Limit (dBuV/m)	Margin (dB)	Antenna Factor (dB/m)	Cable Loss (dB)	Preamp Factor (dB)	Antenna Height (cm)	Table Angle (Degree)	Remark
5638.825	51.38	49.92	68.2	-16.82	32.04	6.7	37.28	274	59	Peak
5651.65	50.76	49.27	69.43	-18.67	32.06	6.71	37.28	274	59	Peak
5915.75	52.27	50.42	75.02	-22.75	32.49	6.86	37.5	274	59	Peak
5958.025	52.2	50.26	68.2	-16	32.57	6.87	37.5	274	59	Peak

Remarks:

- Emission Level = Read Level + Antenna Factor + Cable Loss - Preamp Factor  
Margin value = Emission level – Limit value
- 5745 MHz: Fundamental Frequency
- \*: Out of Restricted Band
- The other emission levels were very low against the limit.

EUT Test Condition		Measurement Detail	
Channel	Channel 157	Frequency Range	1 GHz ~ 40 GHz
Input Power	120 Vac, 60 Hz	Detector Function	Peak (PK) Average (AV)
Environmental Conditions	25 deg. C, 65 % RH	Tested By	Jisyong Wang

### <Spurious Emission>

Antenna Polarity & Test Distance: Horizontal at 3 m										
Frequency (MHz)	Emission Level (dBuV/m)	Read Level (dBuV)	Limit (dBuV/m)	Margin (dB)	Antenna Factor (dB/m)	Cable Loss (dB)	Preamp Factor (dB)	Antenna Height (cm)	Table Angle (Degree)	Remark
5785	95.67	94.13			32.26	6.82	37.54	121	327	Average
5785	105.67	104.13			32.26	6.82	37.54	121	327	Peak
11570	48.59	50.71	54	-5.41	40.13	10.76	53.01	152	231	Average
11570	58.59	60.71	74	-15.41	40.13	10.76	53.01	152	231	Peak
Antenna Polarity & Test Distance: Vertical at 3 m										
Frequency (MHz)	Emission Level (dBuV/m)	Read Level (dBuV)	Limit (dBuV/m)	Margin (dB)	Antenna Factor (dB/m)	Cable Loss (dB)	Preamp Factor (dB)	Antenna Height (cm)	Table Angle (Degree)	Remark
5785	87.41	85.87			32.26	6.82	37.54	276	60	Average
5785	97.42	95.88			32.26	6.82	37.54	276	60	Peak
11570	46.04	48.16	54	-7.96	40.13	10.76	53.01	165	231	Average
11570	56.05	58.17	74	-17.95	40.13	10.76	53.01	165	231	Peak

### <Out of Band Emission (OOBE)>

Antenna Polarity & Test Distance: Horizontal at 3 m										
Frequency (MHz)	Emission Level (dBuV/m)	Read Level (dBuV)	Limit (dBuV/m)	Margin (dB)	Antenna Factor (dB/m)	Cable Loss (dB)	Preamp Factor (dB)	Antenna Height (cm)	Table Angle (Degree)	Remark
5633.6	54.1	52.64	68.2	-14.1	32.04	6.7	37.28	121	327	Peak
5651.175	52.53	51.04	69.07	-16.54	32.06	6.71	37.28	121	327	Peak
5922.4	52.86	50.98	70.12	-17.26	32.52	6.86	37.5	121	327	Peak
5969.425	52.81	50.87	68.2	-15.39	32.57	6.88	37.51	121	327	Peak
Antenna Polarity & Test Distance: Vertical at 3 m										
Frequency (MHz)	Emission Level (dBuV/m)	Read Level (dBuV)	Limit (dBuV/m)	Margin (dB)	Antenna Factor (dB/m)	Cable Loss (dB)	Preamp Factor (dB)	Antenna Height (cm)	Table Angle (Degree)	Remark
5569	51.82	50.38	68.2	-16.38	31.92	6.64	37.12	276	60	Peak
5655.925	51.48	50.05	72.6	-21.12	32.06	6.71	37.34	276	60	Peak
5919.075	51.06	49.21	72.57	-21.51	32.49	6.86	37.5	276	60	Peak
5972.75	52.55	50.58	68.2	-15.65	32.6	6.88	37.51	276	60	Peak

Remarks:

- Emission Level = Read Level + Antenna Factor + Cable Loss - Preamp Factor  
Margin value = Emission level – Limit value
- 5785 MHz: Fundamental Frequency
- \*: Out of Restricted Band
- The other emission levels were very low against the limit.

EUT Test Condition		Measurement Detail	
Channel	Channel 165	Frequency Range	1 GHz ~ 40 GHz
Input Power	120 Vac, 60 Hz	Detector Function	Peak (PK) Average (AV)
Environmental Conditions	25 deg. C, 65 % RH	Tested By	Jisyong Wang

### <Spurious Emission>

Antenna Polarity & Test Distance: Horizontal at 3 m										
Frequency (MHz)	Emission Level (dBuV/m)	Read Level (dBuV)	Limit (dBuV/m)	Margin (dB)	Antenna Factor (dB/m)	Cable Loss (dB)	Preamp Factor (dB)	Antenna Height (cm)	Table Angle (Degree)	Remark
5825	93.52	91.86			32.35	6.84	37.53	124	325	Average
5825	103.53	101.87			32.35	6.84	37.53	124	325	Peak
11650	46.87	49.18	54	-7.13	40.03	10.8	53.14	165	231	Average
11650	56.88	59.19	74	-17.12	40.03	10.8	53.14	165	231	Peak
Antenna Polarity & Test Distance: Vertical at 3 m										
Frequency (MHz)	Emission Level (dBuV/m)	Read Level (dBuV)	Limit (dBuV/m)	Margin (dB)	Antenna Factor (dB/m)	Cable Loss (dB)	Preamp Factor (dB)	Antenna Height (cm)	Table Angle (Degree)	Remark
5825	85.56	83.9			32.35	6.84	37.53	257	62	Average
5825	95.57	93.91			32.35	6.84	37.53	257	62	Peak
11650	45.86	48.17	54	-8.14	40.03	10.8	53.14	196	251	Average
11650	55.87	58.18	74	-18.13	40.03	10.8	53.14	196	251	Peak

### <Out of Band Emission (OOBE)>

Antenna Polarity & Test Distance: Horizontal at 3 m										
Frequency (MHz)	Emission Level (dBuV/m)	Read Level (dBuV)	Limit (dBuV/m)	Margin (dB)	Antenna Factor (dB/m)	Cable Loss (dB)	Preamp Factor (dB)	Antenna Height (cm)	Table Angle (Degree)	Remark
5635.025	52.83	51.37	68.2	-15.37	32.04	6.7	37.28	124	325	Peak
5657.35	53.87	52.44	73.66	-19.79	32.06	6.71	37.34	124	325	Peak
5915.75	52.38	50.53	75.02	-22.64	32.49	6.86	37.5	124	325	Peak
5966.575	53	51.06	68.2	-15.2	32.57	6.88	37.51	124	325	Peak
Antenna Polarity & Test Distance: Vertical at 3 m										
Frequency (MHz)	Emission Level (dBuV/m)	Read Level (dBuV)	Limit (dBuV/m)	Margin (dB)	Antenna Factor (dB/m)	Cable Loss (dB)	Preamp Factor (dB)	Antenna Height (cm)	Table Angle (Degree)	Remark
5619.35	51.87	50.39	68.2	-16.33	32.01	6.69	37.22	257	62	Peak
5657.825	50.43	49	74.01	-23.58	32.06	6.71	37.34	257	62	Peak
5917.65	51.77	49.92	73.62	-21.85	32.49	6.86	37.5	257	62	Peak
5947.575	53.4	51.48	68.2	-14.8	32.55	6.87	37.5	257	62	Peak

Remarks:

- Emission Level = Read Level + Antenna Factor + Cable Loss - Preamp Factor  
Margin value = Emission level – Limit value
- 5825 MHz: Fundamental Frequency
- \*: Out of Restricted Band
- The other emission levels were very low against the limit.

### 802.11n (HT20)

EUT Test Condition		Measurement Detail	
Channel	Channel 36	Frequency Range	1 GHz ~ 40 GHz
Input Power	120 Vac, 60 Hz	Detector Function	Peak (PK) Average (AV)
Environmental Conditions	25 deg. C, 65 % RH	Tested By	Thomas Wei

#### Antenna Polarity & Test Distance: Horizontal at 3 m

Frequency (MHz)	Emission Level (dBuV/m)	Read Level (dBuV)	Limit (dBuV/m)	Margin (dB)	Antenna Factor (dB/m)	Cable Loss (dB)	Preamp Factor (dB)	Antenna Height (cm)	Table Angle (Degree)	Remark
5150	44.55	43.97	54	-9.45	31.56	6.34	37.32	113	119	Average
5150	59	58.42	74	-15	31.56	6.34	37.32	113	119	Peak
5180	97.64	97.02			31.59	6.37	37.34	113	119	Average
5180	107.65	107.03			31.59	6.37	37.34	113	119	Peak
*10360	53.55	56.31	68.2	-14.65	39.48	10.21	52.45	127	214	Peak

#### Antenna Polarity & Test Distance: Vertical at 3 m

Frequency (MHz)	Emission Level (dBuV/m)	Read Level (dBuV)	Limit (dBuV/m)	Margin (dB)	Antenna Factor (dB/m)	Cable Loss (dB)	Preamp Factor (dB)	Antenna Height (cm)	Table Angle (Degree)	Remark
5150	39.64	39.06	54	-14.36	31.56	6.34	37.32	220	30	Average
5150	51.88	51.3	74	-22.12	31.56	6.34	37.32	220	30	Peak
5180	89.99	89.37			31.59	6.37	37.34	220	30	Average
5180	99.61	98.99			31.59	6.37	37.34	220	30	Peak
*10360	53.9	56.66	68.2	-14.3	39.48	10.21	52.45	118	153	Peak

#### Remarks:

- Emission Level = Read Level + Antenna Factor + Cable Loss - Preamp Factor  
Margin value = Emission level – Limit value
- 5180 MHz: Fundamental Frequency
- \*: Out of Restricted Band
- The other emission levels were very low against the limit.

EUT Test Condition		Measurement Detail	
Channel	Channel 40	Frequency Range	1 GHz ~ 40 GHz
Input Power	120 Vac, 60 Hz	Detector Function	Peak (PK) Average (AV)
Environmental Conditions	25 deg. C, 65 % RH	Tested By	Thomas Wei

Antenna Polarity & Test Distance: Horizontal at 3 m										
Frequency (MHz)	Emission Level (dBuV/m)	Read Level (dBuV)	Limit (dBuV/m)	Margin (dB)	Antenna Factor (dB/m)	Cable Loss (dB)	Preamp Factor (dB)	Antenna Height (cm)	Table Angle (Degree)	Remark
5149.94	41.83	41.25	54	-12.17	31.56	6.34	37.32	124	114	Average
5149.94	54.11	53.53	74	-19.89	31.56	6.34	37.32	124	114	Peak
5200	97.64	97.01			31.6	6.39	37.36	124	114	Average
5200	107.36	106.73			31.6	6.39	37.36	124	114	Peak
5350.55	38.67	37.68	54	-15.33	31.7	6.47	37.18	124	114	Average
5350.55	52.09	51.1	74	-21.91	31.7	6.47	37.18	124	114	Peak
*10400	54.34	57.08	68.2	-13.86	39.51	10.2	52.45	174	83	Peak
Antenna Polarity & Test Distance: Vertical at 3 m										
Frequency (MHz)	Emission Level (dBuV/m)	Read Level (dBuV)	Limit (dBuV/m)	Margin (dB)	Antenna Factor (dB/m)	Cable Loss (dB)	Preamp Factor (dB)	Antenna Height (cm)	Table Angle (Degree)	Remark
5145.26	39.01	38.43	54	-14.99	31.56	6.34	37.32	268	32	Average
5145.26	51.13	50.55	74	-22.87	31.56	6.34	37.32	268	32	Peak
5200	89.84	89.21			31.6	6.39	37.36	268	32	Average
5200	99.05	98.42			31.6	6.39	37.36	268	32	Peak
5444.05	38.12	36.99	54	-15.88	31.76	6.5	37.13	268	32	Average
5444.05	51.14	50.01	74	-22.86	31.76	6.5	37.13	268	32	Peak
*10400	54.09	56.83	68.2	-14.11	39.51	10.2	52.45	157	207	Peak

Remarks:

- Emission Level = Read Level + Antenna Factor + Cable Loss - Preamp Factor  
Margin value = Emission level – Limit value
- 5220 MHz: Fundamental Frequency
- \*: Out of Restricted Band
- The other emission levels were very low against the limit.

EUT Test Condition		Measurement Detail	
Channel	Channel 48	Frequency Range	1 GHz ~ 40 GHz
Input Power	120 Vac, 60 Hz	Detector Function	Peak (PK) Average (AV)
Environmental Conditions	25 deg. C, 65 % RH	Tested By	Thomas Wei

Antenna Polarity & Test Distance: Horizontal at 3 m										
Frequency (MHz)	Emission Level (dBuV/m)	Read Level (dBuV)	Limit (dBuV/m)	Margin (dB)	Antenna Factor (dB/m)	Cable Loss (dB)	Preamp Factor (dB)	Antenna Height (cm)	Table Angle (Degree)	Remark
5149.94	41.6	41.02	54	-12.4	31.56	6.34	37.32	120	133	Average
5149.94	53.47	52.89	74	-20.53	31.56	6.34	37.32	120	133	Peak
5240	98.17	97.45			31.62	6.42	37.32	120	133	Average
5240	107.57	106.85			31.62	6.42	37.32	120	133	Peak
5350	40.25	39.26	54	-13.75	31.7	6.47	37.18	120	133	Average
5350	52.54	51.55	74	-21.46	31.7	6.47	37.18	120	133	Peak
*10480	53.8	56.64	68.2	-14.4	39.6	10.22	52.66	165	306	Peak
Antenna Polarity & Test Distance: Vertical at 3 m										
Frequency (MHz)	Emission Level (dBuV/m)	Read Level (dBuV)	Limit (dBuV/m)	Margin (dB)	Antenna Factor (dB/m)	Cable Loss (dB)	Preamp Factor (dB)	Antenna Height (cm)	Table Angle (Degree)	Remark
5139.32	38.49	37.91	54	-15.51	31.55	6.33	37.3	207	32	Average
5139.32	50.75	50.17	74	-23.25	31.55	6.33	37.3	207	32	Peak
5240	90.42	89.7			31.62	6.42	37.32	207	32	Average
5240	100	99.28			31.62	6.42	37.32	207	32	Peak
5352.42	38.25	37.26	54	-15.75	31.7	6.47	37.18	207	32	Average
5352.42	51.42	50.43	74	-22.58	31.7	6.47	37.18	207	32	Peak
*10480	53.65	56.49	68.2	-14.55	39.6	10.22	52.66	129	137	Peak

Remarks:

- Emission Level = Read Level + Antenna Factor + Cable Loss - Preamp Factor  
Margin value = Emission level – Limit value
- 5240 MHz: Fundamental Frequency
- \*: Out of Restricted Band
- The other emission levels were very low against the limit.



EUT Test Condition		Measurement Detail	
Channel	Channel 149	Frequency Range	1 GHz ~ 40 GHz
Input Power	120 Vac, 60 Hz	Detector Function	Peak (PK) Average (AV)
Environmental Conditions	25 deg. C, 65 % RH	Tested By	Jisyong Wang

### <Spurious Emission>

Antenna Polarity & Test Distance: Horizontal at 3 m										
Frequency (MHz)	Emission Level (dBuV/m)	Read Level (dBuV)	Limit (dBuV/m)	Margin (dB)	Antenna Factor (dB/m)	Cable Loss (dB)	Preamp Factor (dB)	Antenna Height (cm)	Table Angle (Degree)	Remark
5745	94.67	93.15			32.21	6.78	37.47	136	323	Average
5745	104.67	103.15			32.21	6.78	37.47	136	323	Peak
11490	47.42	49.29	54	-6.58	40.25	10.66	52.78	152	231	Average
11490	57.43	59.3	74	-16.57	40.25	10.66	52.78	152	231	Peak
Antenna Polarity & Test Distance: Vertical at 3 m										
Frequency (MHz)	Emission Level (dBuV/m)	Read Level (dBuV)	Limit (dBuV/m)	Margin (dB)	Antenna Factor (dB/m)	Cable Loss (dB)	Preamp Factor (dB)	Antenna Height (cm)	Table Angle (Degree)	Remark
5745	87.27	85.75			32.21	6.78	37.47	274	61	Average
5745	97.27	95.75			32.21	6.78	37.47	274	61	Peak
11490	47.47	49.34	54	-6.53	40.25	10.66	52.78	152	222	Average
11490	57.48	59.35	74	-16.52	40.25	10.66	52.78	152	222	Peak

### <Out of Band Emission (OOBE)>

Antenna Polarity & Test Distance: Horizontal at 3 m										
Frequency (MHz)	Emission Level (dBuV/m)	Read Level (dBuV)	Limit (dBuV/m)	Margin (dB)	Antenna Factor (dB/m)	Cable Loss (dB)	Preamp Factor (dB)	Antenna Height (cm)	Table Angle (Degree)	Remark
5618.875	52.75	51.27	68.2	-15.45	32.01	6.69	37.22	136	323	Peak
5655.45	52.89	51.46	72.25	-19.36	32.06	6.71	37.34	136	323	Peak
5922.4	51	49.12	70.12	-19.12	32.52	6.86	37.5	136	323	Peak
5945.2	53.1	51.18	68.2	-15.1	32.55	6.87	37.5	136	323	Peak
Antenna Polarity & Test Distance: Vertical at 3 m										
Frequency (MHz)	Emission Level (dBuV/m)	Read Level (dBuV)	Limit (dBuV/m)	Margin (dB)	Antenna Factor (dB/m)	Cable Loss (dB)	Preamp Factor (dB)	Antenna Height (cm)	Table Angle (Degree)	Remark
5614.125	51.95	50.5	68.2	-16.25	31.98	6.69	37.22	274	61	Peak
5652.125	51.05	49.56	69.78	-18.73	32.06	6.71	37.28	274	61	Peak
5919.55	50.75	48.9	72.22	-21.47	32.49	6.86	37.5	274	61	Peak
6003.15	53.01	51	68.2	-15.19	32.63	6.89	37.51	274	61	Peak

Remarks:

- Emission Level = Read Level + Antenna Factor + Cable Loss - Preamp Factor  
Margin value = Emission level – Limit value
- 5745 MHz: Fundamental Frequency
- \*: Out of Restricted Band
- The other emission levels were very low against the limit.

EUT Test Condition		Measurement Detail	
Channel	Channel 157	Frequency Range	1 GHz ~ 40 GHz
Input Power	120 Vac, 60 Hz	Detector Function	Peak (PK) Average (AV)
Environmental Conditions	25 deg. C, 65 % RH	Tested By	Jisyong Wang

### <Spurious Emission>

Antenna Polarity & Test Distance: Horizontal at 3 m										
Frequency (MHz)	Emission Level (dBuV/m)	Read Level (dBuV)	Limit (dBuV/m)	Margin (dB)	Antenna Factor (dB/m)	Cable Loss (dB)	Preamp Factor (dB)	Antenna Height (cm)	Table Angle (Degree)	Remark
5785	93.69	92.15			32.26	6.82	37.54	116	327	Average
5785	103.77	102.23			32.26	6.82	37.54	116	327	Peak
11570	46.66	48.78	54	-7.34	40.13	10.76	53.01	102	231	Average
11570	56.61	58.73	74	-17.39	40.13	10.76	53.01	102	231	Peak
Antenna Polarity & Test Distance: Vertical at 3 m										
Frequency (MHz)	Emission Level (dBuV/m)	Read Level (dBuV)	Limit (dBuV/m)	Margin (dB)	Antenna Factor (dB/m)	Cable Loss (dB)	Preamp Factor (dB)	Antenna Height (cm)	Table Angle (Degree)	Remark
5785	86.86	85.32			32.26	6.82	37.54	277	59	Average
5785	96.86	95.32			32.26	6.82	37.54	277	59	Peak
11570	46.4	48.52	54	-7.6	40.13	10.76	53.01	265	231	Average
11570	56.4	58.52	74	-17.6	40.13	10.76	53.01	265	231	Peak

### <Out of Band Emission (OOBE)>

Antenna Polarity & Test Distance: Horizontal at 3 m										
Frequency (MHz)	Emission Level (dBuV/m)	Read Level (dBuV)	Limit (dBuV/m)	Margin (dB)	Antenna Factor (dB/m)	Cable Loss (dB)	Preamp Factor (dB)	Antenna Height (cm)	Table Angle (Degree)	Remark
5631.225	53.12	51.69	68.2	-15.08	32.01	6.7	37.28	116	327	Peak
5657.825	53.71	52.28	74.01	-20.3	32.06	6.71	37.34	116	327	Peak
5920.025	51.9	50.05	71.87	-19.97	32.49	6.86	37.5	116	327	Peak
5987.475	52.44	50.47	68.2	-15.76	32.6	6.88	37.51	116	327	Peak
Antenna Polarity & Test Distance: Vertical at 3 m										
Frequency (MHz)	Emission Level (dBuV/m)	Read Level (dBuV)	Limit (dBuV/m)	Margin (dB)	Antenna Factor (dB/m)	Cable Loss (dB)	Preamp Factor (dB)	Antenna Height (cm)	Table Angle (Degree)	Remark
5639.775	51.27	49.81	68.2	-16.93	32.04	6.7	37.28	277	59	Peak
5654.975	51.04	49.61	71.9	-20.86	32.06	6.71	37.34	277	59	Peak
5923.825	51.81	49.93	69.07	-17.26	32.52	6.86	37.5	277	59	Peak
6012.65	52.19	50.12	68.2	-16.01	32.67	6.9	37.5	277	59	Peak

Remarks:

- Emission Level = Read Level + Antenna Factor + Cable Loss - Preamp Factor  
Margin value = Emission level – Limit value
- 5785 MHz: Fundamental Frequency
- \*: Out of Restricted Band
- The other emission levels were very low against the limit.

EUT Test Condition		Measurement Detail	
Channel	Channel 165	Frequency Range	1 GHz ~ 40 GHz
Input Power	120 Vac, 60 Hz	Detector Function	Peak (PK) Average (AV)
Environmental Conditions	25 deg. C, 65 % RH	Tested By	Jisyong Wang

### <Spurious Emission>

Antenna Polarity & Test Distance: Horizontal at 3 m										
Frequency (MHz)	Emission Level (dBuV/m)	Read Level (dBuV)	Limit (dBuV/m)	Margin (dB)	Antenna Factor (dB/m)	Cable Loss (dB)	Preamp Factor (dB)	Antenna Height (cm)	Table Angle (Degree)	Remark
5825	92.25	90.59			32.35	6.84	37.53	127	326	Average
5825	102.25	100.59			32.35	6.84	37.53	127	326	Peak
11650	46.45	48.76	54	-7.55	40.03	10.8	53.14	123	251	Average
11650	56.46	58.77	74	-17.54	40.03	10.8	53.14	123	251	Peak
Antenna Polarity & Test Distance: Vertical at 3 m										
Frequency (MHz)	Emission Level (dBuV/m)	Read Level (dBuV)	Limit (dBuV/m)	Margin (dB)	Antenna Factor (dB/m)	Cable Loss (dB)	Preamp Factor (dB)	Antenna Height (cm)	Table Angle (Degree)	Remark
5825	94.48	92.82			32.35	6.84	37.53	268	60	Average
5825	95.49	93.83			32.35	6.84	37.53	268	60	Peak
11650	47.09	49.4	54	-6.91	40.03	10.8	53.14	132	265	Average
11650	57.1	59.41	74	-16.9	40.03	10.8	53.14	132	265	Peak

### <Out of Band Emission (OOBE)>

Antenna Polarity & Test Distance: Horizontal at 3 m										
Frequency (MHz)	Emission Level (dBuV/m)	Read Level (dBuV)	Limit (dBuV/m)	Margin (dB)	Antenna Factor (dB/m)	Cable Loss (dB)	Preamp Factor (dB)	Antenna Height (cm)	Table Angle (Degree)	Remark
5639.775	52.46	51	68.2	-15.74	32.04	6.7	37.28	127	326	Peak
5660.2	51.74	50.31	75.77	-24.03	32.06	6.71	37.34	127	326	Peak
5915.275	52.08	50.23	75.37	-23.29	32.49	6.86	37.5	127	326	Peak
5983.675	53.12	51.15	68.2	-15.08	32.6	6.88	37.51	127	326	Peak
Antenna Polarity & Test Distance: Vertical at 3 m										
Frequency (MHz)	Emission Level (dBuV/m)	Read Level (dBuV)	Limit (dBuV/m)	Margin (dB)	Antenna Factor (dB/m)	Cable Loss (dB)	Preamp Factor (dB)	Antenna Height (cm)	Table Angle (Degree)	Remark
5638.825	51.54	50.08	68.2	-16.66	32.04	6.7	37.28	268	60	Peak
5657.35	50.97	49.54	73.66	-22.69	32.06	6.71	37.34	268	60	Peak
5923.35	51.2	49.32	69.42	-18.22	32.52	6.86	37.5	268	60	Peak
5930.95	52.49	50.61	68.2	-15.71	32.52	6.86	37.5	268	60	Peak

Remarks:

- Emission Level = Read Level + Antenna Factor + Cable Loss - Preamp Factor  
Margin value = Emission level – Limit value
- 5825 MHz: Fundamental Frequency
- \*: Out of Restricted Band
- The other emission levels were very low against the limit.

### 802.11n (HT40)

EUT Test Condition		Measurement Detail	
Channel	Channel 38	Frequency Range	1 GHz ~ 40 GHz
Input Power	120 Vac, 60 Hz	Detector Function	Peak (PK) Average (AV)
Environmental Conditions	25 deg. C, 65 % RH	Tested By	Jisyong Wang

Antenna Polarity & Test Distance: Horizontal at 3 m										
Frequency (MHz)	Emission Level (dBUV/m)	Read Level (dBUV)	Limit (dBUV/m)	Margin (dB)	Antenna Factor (dB/m)	Cable Loss (dB)	Preamp Factor (dB)	Antenna Height (cm)	Table Angle (Degree)	Remark
5146	45.56	44.98	54	-8.44	31.56	6.34	37.32	112	335	Average
5146	61.05	60.47	74	-12.95	31.56	6.34	37.32	112	335	Peak
5190	91.7	91.07			31.59	6.38	37.34	112	335	Average
5190	101.71	101.08			31.59	6.38	37.34	112	335	Peak
5357	39.32	38.33	54	-14.68	31.7	6.47	37.18	112	335	Average
5357	51.71	50.72	74	-22.29	31.7	6.47	37.18	112	335	Peak
*10380	56.16	58.9	68.2	-12.04	39.5	10.21	52.45	165	222	Peak

Antenna Polarity & Test Distance: Vertical at 3 m										
Frequency (MHz)	Emission Level (dBUV/m)	Read Level (dBUV)	Limit (dBUV/m)	Margin (dB)	Antenna Factor (dB/m)	Cable Loss (dB)	Preamp Factor (dB)	Antenna Height (cm)	Table Angle (Degree)	Remark
5149	41.49	40.91	54	-12.51	31.56	6.34	37.32	100	285	Average
5149	53.42	52.84	74	-20.58	31.56	6.34	37.32	100	285	Peak
5190	85.86	85.23			31.59	6.38	37.34	100	285	Average
5190	95.86	95.23			31.59	6.38	37.34	100	285	Peak
5370	39.15	38.14	54	-14.85	31.72	6.47	37.18	100	285	Average
5370	51.34	50.33	74	-22.66	31.72	6.47	37.18	100	285	Peak
*10380	56.43	59.17	68.2	-11.77	39.5	10.21	52.45	165	231	Peak

Remarks:

- Emission Level = Read Level + Antenna Factor + Cable Loss - Preamp Factor  
Margin value = Emission level – Limit value
- 5190 MHz: Fundamental Frequency
- \*: Out of Restricted Band
- The other emission levels were very low against the limit.

EUT Test Condition		Measurement Detail	
Channel	Channel 46	Frequency Range	1 GHz ~ 40 GHz
Input Power	120 Vac, 60 Hz	Detector Function	Peak (PK) Average (AV)
Environmental Conditions	25 deg. C, 65 % RH	Tested By	Jisyong Wang

Antenna Polarity & Test Distance: Horizontal at 3 m										
Frequency (MHz)	Emission Level (dBuV/m)	Read Level (dBuV)	Limit (dBuV/m)	Margin (dB)	Antenna Factor (dB/m)	Cable Loss (dB)	Preamp Factor (dB)	Antenna Height (cm)	Table Angle (Degree)	Remark
5091.26	40.27	39.73	54	-13.73	31.53	6.28	37.27	127	338	Average
5091.26	52.43	51.89	74	-21.57	31.53	6.28	37.27	127	338	Peak
5230	89.93	89.22			31.62	6.41	37.32	127	338	Average
5230	99.96	99.25			31.62	6.41	37.32	127	338	Peak
5387.29	39.84	38.82	54	-14.16	31.73	6.47	37.18	127	338	Average
5387.29	51.59	50.57	74	-22.41	31.73	6.47	37.18	127	338	Peak
*10460	56.04	58.84	68.2	-12.16	39.57	10.22	52.59	152	222	Peak
Antenna Polarity & Test Distance: Vertical at 3 m										
Frequency (MHz)	Emission Level (dBuV/m)	Read Level (dBuV)	Limit (dBuV/m)	Margin (dB)	Antenna Factor (dB/m)	Cable Loss (dB)	Preamp Factor (dB)	Antenna Height (cm)	Table Angle (Degree)	Remark
5029	39.16	38.69	54	-14.84	31.48	6.23	37.24	100	292	Average
5029	50.64	50.17	74	-23.36	31.48	6.23	37.24	100	292	Peak
5230	85.93	85.22			31.62	6.41	37.32	100	292	Average
5230	95.94	95.23			31.62	6.41	37.32	100	292	Peak
5454	39.34	38.14	54	-14.66	31.77	6.51	37.08	100	292	Average
5454	51.37	50.17	74	-22.63	31.77	6.51	37.08	100	292	Peak
*10460	55.97	58.77	68.2	-12.23	39.57	10.22	52.59	185	231	Peak

Remarks:

- Emission Level = Read Level + Antenna Factor + Cable Loss - Preamp Factor  
Margin value = Emission level – Limit value
- 5230 MHz: Fundamental Frequency
- \*: Out of Restricted Band
- The other emission levels were very low against the limit.

EUT Test Condition		Measurement Detail	
Channel	Channel 151	Frequency Range	1 GHz ~ 40 GHz
Input Power	120 Vac, 60 Hz	Detector Function	Peak (PK) Average (AV)
Environmental Conditions	25 deg. C, 65 % RH	Tested By	Jisyong Wang

### <Spurious Emission>

Antenna Polarity & Test Distance: Horizontal at 3 m										
Frequency (MHz)	Emission Level (dBuV/m)	Read Level (dBuV)	Limit (dBuV/m)	Margin (dB)	Antenna Factor (dB/m)	Cable Loss (dB)	Preamp Factor (dB)	Antenna Height (cm)	Table Angle (Degree)	Remark
5755	93.07	91.52			32.23	6.79	37.47	118	327	Average
5755	103.12	101.57			32.23	6.79	37.47	118	327	Peak
11510	47.28	49.17	54	-6.72	40.23	10.69	52.81	165	231	Average
11510	57.29	59.18	74	-16.71	40.23	10.69	52.81	165	231	Peak
Antenna Polarity & Test Distance: Vertical at 3 m										
Frequency (MHz)	Emission Level (dBuV/m)	Read Level (dBuV)	Limit (dBuV/m)	Margin (dB)	Antenna Factor (dB/m)	Cable Loss (dB)	Preamp Factor (dB)	Antenna Height (cm)	Table Angle (Degree)	Remark
5755	82.6	81.05			32.23	6.79	37.47	278	56	Average
5755	92.38	90.83			32.23	6.79	37.47	278	56	Peak
11510	47.48	49.37	54	-6.52	40.23	10.69	52.81	132	295	Average
11510	57.49	59.38	74	-16.51	40.23	10.69	52.81	132	295	Peak

### <Out of Band Emission (OOBE)>

Antenna Polarity & Test Distance: Horizontal at 3 m										
Frequency (MHz)	Emission Level (dBuV/m)	Read Level (dBuV)	Limit (dBuV/m)	Margin (dB)	Antenna Factor (dB/m)	Cable Loss (dB)	Preamp Factor (dB)	Antenna Height (cm)	Table Angle (Degree)	Remark
5600.825	53.69	52.19	68.2	-14.51	31.98	6.68	37.16	118	327	Peak
5656.4	53.08	51.65	72.95	-19.87	32.06	6.71	37.34	118	327	Peak
5918.125	52.44	50.59	73.27	-20.83	32.49	6.86	37.5	118	327	Peak
5988.425	52.61	50.63	68.2	-15.59	32.6	6.89	37.51	118	327	Peak
Antenna Polarity & Test Distance: Vertical at 3 m										
Frequency (MHz)	Emission Level (dBuV/m)	Read Level (dBuV)	Limit (dBuV/m)	Margin (dB)	Antenna Factor (dB/m)	Cable Loss (dB)	Preamp Factor (dB)	Antenna Height (cm)	Table Angle (Degree)	Remark
5636.45	53.37	51.91	68.2	-14.83	32.04	6.7	37.28	278	56	Peak
5654.025	51.2	49.77	71.19	-19.99	32.06	6.71	37.34	278	56	Peak
5921.45	51.7	49.85	70.82	-19.12	32.49	6.86	37.5	278	56	Peak
5998.875	52.59	50.58	68.2	-15.61	32.63	6.89	37.51	278	56	Peak

Remarks:

- Emission Level = Read Level + Antenna Factor + Cable Loss - Preamp Factor  
Margin value = Emission level – Limit value
- 5755 MHz: Fundamental Frequency
- \*: Out of Restricted Band
- The other emission levels were very low against the limit.

EUT Test Condition		Measurement Detail	
Channel	Channel 159	Frequency Range	1 GHz ~ 40 GHz
Input Power	120 Vac, 60 Hz	Detector Function	Peak (PK) Average (AV)
Environmental Conditions	25 deg. C, 65 % RH	Tested By	Jisyong Wang

### <Spurious Emission>

Antenna Polarity & Test Distance: Horizontal at 3 m										
Frequency (MHz)	Emission Level (dBuV/m)	Read Level (dBuV)	Limit (dBuV/m)	Margin (dB)	Antenna Factor (dB/m)	Cable Loss (dB)	Preamp Factor (dB)	Antenna Height (cm)	Table Angle (Degree)	Remark
5795	91.36	89.78			32.29	6.83	37.54	128	324	Average
5795	101.44	99.86			32.29	6.83	37.54	128	324	Peak
11590	46.97	49.09	54	-7.03	40.11	10.78	53.01	132	256	Average
11590	56.98	59.1	74	-17.02	40.11	10.78	53.01	132	256	Peak
Antenna Polarity & Test Distance: Vertical at 3 m										
Frequency (MHz)	Emission Level (dBuV/m)	Read Level (dBuV)	Limit (dBuV/m)	Margin (dB)	Antenna Factor (dB/m)	Cable Loss (dB)	Preamp Factor (dB)	Antenna Height (cm)	Table Angle (Degree)	Remark
5795	84.05	82.47			32.29	6.83	37.54	283	61	Average
5795	94.05	92.47			32.29	6.83	37.54	283	61	Peak
11590	46.27	48.39	54	-7.73	40.11	10.78	53.01	231	256	Average
11590	56.32	58.44	74	-17.68	40.11	10.78	53.01	231	256	Peak

### <Out of Band Emission (OOBE)>

Antenna Polarity & Test Distance: Horizontal at 3 m										
Frequency (MHz)	Emission Level (dBuV/m)	Read Level (dBuV)	Limit (dBuV/m)	Margin (dB)	Antenna Factor (dB/m)	Cable Loss (dB)	Preamp Factor (dB)	Antenna Height (cm)	Table Angle (Degree)	Remark
5635.975	52.72	51.26	68.2	-15.48	32.04	6.7	37.28	128	324	Peak
5651.175	53.87	52.38	69.07	-15.2	32.06	6.71	37.28	128	324	Peak
5919.075	53.32	51.47	72.57	-19.25	32.49	6.86	37.5	128	324	Peak
5950.425	52.74	50.82	68.2	-15.46	32.55	6.87	37.5	128	324	Peak
Antenna Polarity & Test Distance: Vertical at 3 m										
Frequency (MHz)	Emission Level (dBuV/m)	Read Level (dBuV)	Limit (dBuV/m)	Margin (dB)	Antenna Factor (dB/m)	Cable Loss (dB)	Preamp Factor (dB)	Antenna Height (cm)	Table Angle (Degree)	Remark
5597.975	51.49	50.02	68.2	-16.71	31.95	6.68	37.16	283	61	Peak
5651.175	51.32	49.83	69.07	-17.75	32.06	6.71	37.28	283	61	Peak
5923.35	51.31	49.43	69.42	-18.11	32.52	6.86	37.5	283	61	Peak
6020.725	52.24	50.17	68.2	-15.96	32.67	6.9	37.5	283	61	Peak

Remarks:

- Emission Level = Read Level + Antenna Factor + Cable Loss - Preamp Factor  
Margin value = Emission level – Limit value
- 5795 MHz: Fundamental Frequency
- \*: Out of Restricted Band
- The other emission levels were very low against the limit.

**9 kHz ~ 30 MHz Data:**

The amplitude of spurious emissions attenuated more than 20 dB below the permissible value is not required to be report.

**30 MHz ~ 1 GHz Worst-Case Data:**

**Mode A**

**802.11n (HT40)**

EUT Test Condition		Measurement Detail	
Channel	Channel 38	Frequency Range	30 MHz ~ 1 GHz
Input Power	120 Vac, 60 Hz	Detector Function	Peak (PK)
Environmental Conditions	25 deg. C, 65 % RH	Tested By	Jisyong Wang

Antenna Polarity & Test Distance: Horizontal at 3 m										
Frequency (MHz)	Emission Level (dBuV/m)	Read Level (dBuV)	Limit (dBuV/m)	Margin (dB)	Antenna Factor (dB/m)	Cable Loss (dB)	Preamp Factor (dB)	Antenna Height (cm)	Table Angle (Degree)	Remark
99.84	23.92	46.07	43.5	-19.58	9.06	0.75	31.96	130	65	Peak
167.74	30.55	49.29	43.5	-12.95	11.96	1.06	31.76	112	354	Peak
237.58	31.43	50.85	46	-14.57	10.95	1.43	31.8	116	329	Peak
321	26.98	43.66	46	-19.02	13.45	1.75	31.88	138	302	Peak
444.19	24.78	38.3	46	-21.22	16.21	2.26	31.99	135	338	Peak
803.09	28.88	34.37	46	-17.12	22.27	3.68	31.44	125	103	Peak
Antenna Polarity & Test Distance: Vertical at 3 m										
Frequency (MHz)	Emission Level (dBuV/m)	Read Level (dBuV)	Limit (dBuV/m)	Margin (dB)	Antenna Factor (dB/m)	Cable Loss (dB)	Preamp Factor (dB)	Antenna Height (cm)	Table Angle (Degree)	Remark
47.46	28.82	46.24	40	-11.18	13.28	0.52	31.22	106	34	Peak
69.77	32.18	52.59	40	-7.82	10.77	0.64	31.82	130	317	Peak
170.65	28.1	47.1	43.5	-15.4	11.67	1.07	31.74	114	358	Peak
229.82	26.62	46.48	46	-19.38	10.62	1.38	31.86	101	296	Peak
444.19	26.76	40.28	46	-19.24	16.21	2.26	31.99	136	296	Peak
757.5	27.21	33.46	46	-18.79	21.63	3.53	31.41	121	147	Peak

Remarks:

1. Emission Level = Read Level + Antenna Factor + Cable Loss - Preamp Factor
2. Margin value = Emission level – Limit value
3. The other emission levels were very low against the limit.



**Mode B**  
**802.11a**

EUT Test Condition		Measurement Detail	
Channel	Channel 157	Frequency Range	30 MHz ~ 1 GHz
Input Power	120 Vac, 60 Hz	Detector Function	Peak (PK)
Environmental Conditions	25 deg. C, 65 % RH	Tested By	Jisyong Wang

Antenna Polarity & Test Distance: Horizontal at 3 m										
Frequency (MHz)	Emission Level (dBuV/m)	Read Level (dBuV)	Limit (dBuV/m)	Margin (dB)	Antenna Factor (dB/m)	Cable Loss (dB)	Preamp Factor (dB)	Antenna Height (cm)	Table Angle (Degree)	Remark
288.02	42.38	59.87	46	-3.62	12.6	1.61	31.7	152	231	Peak
335.55	42.61	58.81	46	-3.39	13.8	1.82	31.82	165	295	Peak
384.05	42.47	57.48	46	-3.53	14.96	2.02	31.99	147	185	Peak
480.08	40.89	53.4	46	-5.11	16.93	2.41	31.85	102	231	Peak
576.11	34.46	44.7	46	-11.54	19.06	2.8	32.1	165	285	Peak
673.11	41.16	49.3	46	-4.84	20.49	3.19	31.82	111	147	Peak
Antenna Polarity & Test Distance: Vertical at 3 m										
Frequency (MHz)	Emission Level (dBuV/m)	Read Level (dBuV)	Limit (dBuV/m)	Margin (dB)	Antenna Factor (dB/m)	Cable Loss (dB)	Preamp Factor (dB)	Antenna Height (cm)	Table Angle (Degree)	Remark
86.26	26.43	49.28	40	-13.57	8.23	0.7	31.78	165	295	Peak
288.02	33.18	50.67	46	-12.82	12.6	1.61	31.7	111	102	Peak
384.05	36.15	51.16	46	-9.85	14.96	2.02	31.99	285	295	Peak
480.08	38.67	51.18	46	-7.33	16.93	2.41	31.85	165	247	Peak
577.08	34.15	44.38	46	-11.85	19.08	2.8	32.11	100	360	Peak
746.83	43.06	49.43	46	-2.94	21.48	3.5	31.35	152	360	Peak

Remarks:

1. Emission Level = Read Level + Antenna Factor + Cable Loss - Preamp Factor
2. Margin value = Emission level – Limit value
3. The other emission levels were very low against the limit.

## 4.2 Conducted Emission Measurement

### 4.2.1 Limits of Conducted Emission Measurement

Frequency (MHz)	Conducted Limit (dBuV)	
	Quasi-Peak	Average
0.15 - 0.5	66 - 56	56 - 46
0.50 - 5.0	56	46
5.0 - 30.0	60	50

- Note: 1. The lower limit shall apply at the transition frequencies.  
 2. The limit decreases in line with the logarithm of the frequency in the range of 0.15 to 0.50 MHz.

### 4.2.2 Test Instruments

Description & Manufacturer	Model No.	Serial No.	Date of Calibration	Due Date of Calibration
Test Receiver ROHDE & SCHWARZ	ESCI	100613	Nov. 23, 2017	Nov. 22, 2018
RF signal cable Woken	5D-FB	Cable-cond1-01	Sep. 05, 2018	Sep. 04, 2019
LISN/AMN ROHDE & SCHWARZ (EUT)	ENV216	101826	Feb. 26, 2018	Feb. 25, 2019
LISN/AMN ROHDE & SCHWARZ (Peripheral)	ESH3-Z5	100311	Aug. 19, 2018	Aug. 18, 2019
Software ADT	BV ADT_Cond_ V7.3.7.4	NA	NA	NA

- Note: 1. The calibration interval of the above test instruments is 12 months and the calibrations are traceable to NML/ROC and NIST/USA.  
 2. The test was performed in HwaYa Shielded Room 1.  
 3. The VCCI Site Registration No. is C-2040.

#### 4.2.3 Test Procedures

- a. The EUT was placed 0.4 meters from the conducting wall of the shielded room with EUT being connected to the power mains through a line impedance stabilization network (LISN). Other support units were connected to the power mains through another LISN. The two LISNs provide 50 ohm/ 50uH of coupling impedance for the measuring instrument.
- b. Both lines of the power mains connected to the EUT were checked for maximum conducted interference.
- c. The frequency range from 150 kHz to 30 MHz was searched. Emission levels under (Limit -20 dB) was not recorded.

**Note:** All modes of operation were investigated and the worst-case emissions are reported.

#### 4.2.4 Deviation from Test Standard

No deviation.

#### 4.2.5 Test Setup

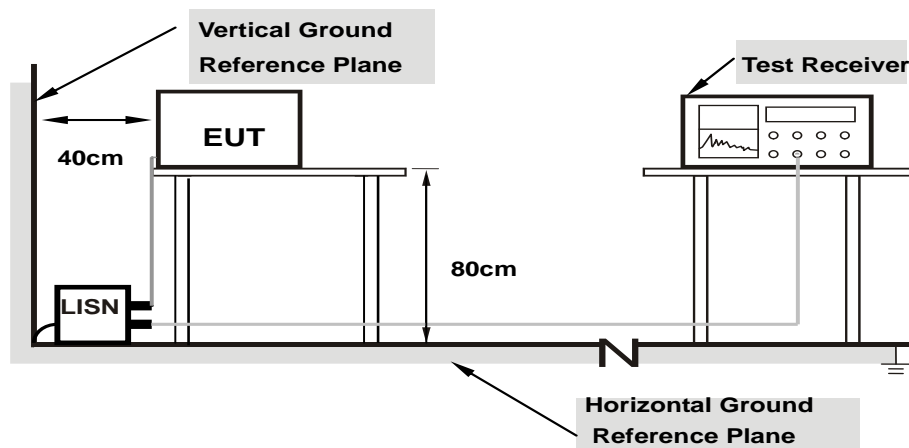

- Note:**
- 1.Support units were connected to second LISN.
  - 2.Both of LISNs (AMN) are 80 cm from EUT and at least 80 from other units and other metal planes

For the actual test configuration, please refer to the attached file (Test Setup Photo).

#### 4.2.6 EUT Operating Conditions

- a. Placed the EUT on a testing table.
- b. Use the software to control the EUT under transmission condition continuously at specific channel frequency.

#### 4.2.7 Test Results

##### Mode A

Frequency Range	150kHz ~ 30MHz	Detector Function & Resolution Bandwidth	Quasi-Peak (QP) / Average (AV), 9kHz
Input Power	120Vac, 60Hz	Environmental Conditions	25°C, 65%RH
Tested by	Getaz Yang	Test Date	2018/9/9

Phase Of Power : Line (L)										
No	Frequency (MHz)	Correction Factor (dB)	Reading Value (dBuV)		Emission Level (dBuV)		Limit (dBuV)		Margin (dB)	
			Q.P.	AV.	Q.P.	AV.	Q.P.	AV.	Q.P.	AV.
1	0.15000	10.39	35.62	20.83	46.01	31.22	66.00	56.00	-19.99	-24.78
2	0.17022	10.39	32.88	18.14	43.27	28.53	64.95	54.95	-21.68	-26.42
3	0.20600	10.39	28.51	14.00	38.90	24.39	63.37	53.37	-24.47	-28.98
4	0.47559	10.41	11.15	6.53	21.56	16.94	56.42	46.42	-34.86	-29.48
5	4.25788	10.57	6.33	-0.95	16.90	9.62	56.00	46.00	-39.10	-36.38
6	21.71800	11.42	5.81	0.56	17.23	11.98	60.00	50.00	-42.77	-38.02

##### Remarks:

1. Q.P. and AV. are abbreviations of quasi-peak and average individually.
2. The emission levels of other frequencies were very low against the limit.
3. Margin value = Emission level – Limit value
4. Correction factor = Insertion loss + Cable loss
5. Emission Level = Correction Factor + Reading Value

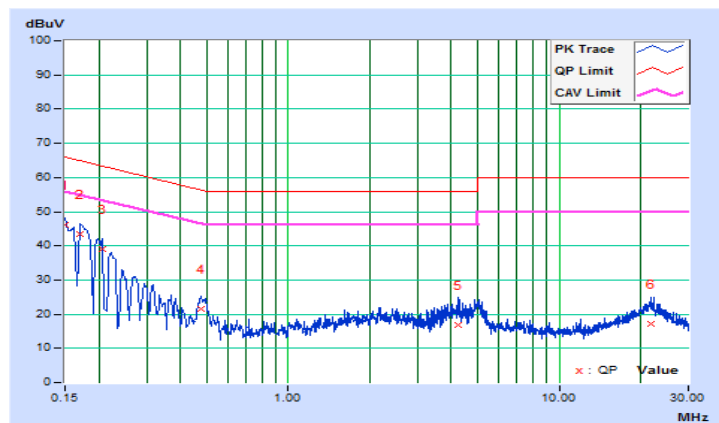

Frequency Range	150kHz ~ 30MHz	Detector Function & Resolution Bandwidth	Quasi-Peak (QP) / Average (AV), 9kHz
Input Power	120Vac, 60Hz	Environmental Conditions	25°C, 65%RH
Tested by	Getaz Yang	Test Date	2018/9/9

Phase Of Power : Neutral (N)										
No	Frequency (MHz)	Correction Factor (dB)	Reading Value (dBuV)		Emission Level (dBuV)		Limit (dBuV)		Margin (dB)	
			Q.P.	AV.	Q.P.	AV.	Q.P.	AV.	Q.P.	AV.
1	0.15000	10.15	36.51	21.72	46.66	31.87	66.00	56.00	-19.34	-24.13
2	0.16579	10.16	34.09	19.63	44.25	29.79	65.17	55.17	-20.92	-25.38
3	0.21400	10.16	25.78	12.56	35.94	22.72	63.05	53.05	-27.11	-30.33
4	0.49346	10.17	13.60	9.24	23.77	19.41	56.11	46.11	-32.34	-26.70
5	4.68200	10.35	8.61	2.28	18.96	12.63	56.00	46.00	-37.04	-33.37
6	21.86200	11.01	6.86	1.28	17.87	12.29	60.00	50.00	-42.13	-37.71

Remarks:

1. Q.P. and AV. are abbreviations of quasi-peak and average individually.
2. The emission levels of other frequencies were very low against the limit.
3. Margin value = Emission level – Limit value
4. Correction factor = Insertion loss + Cable loss
5. Emission Level = Correction Factor + Reading Value

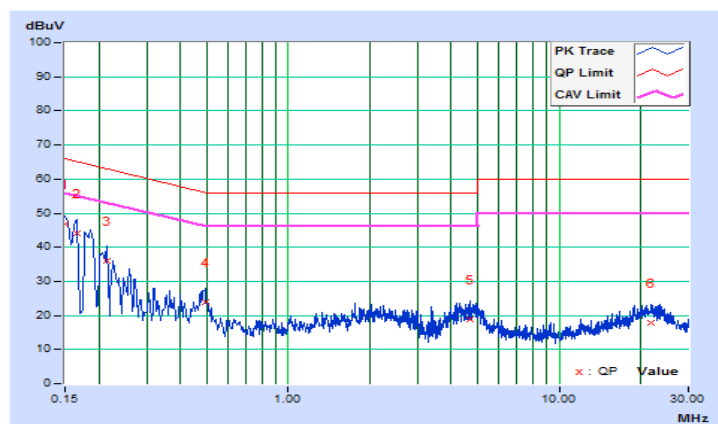

**Mode B**

Frequency Range	150kHz ~ 30MHz	Detector Function & Resolution Bandwidth	Quasi-Peak (QP) / Average (AV), 9kHz
Input Power	120Vac, 60Hz	Environmental Conditions	25°C, 65%RH
Tested by	Jisyong Wang	Test Date	2018/9/9

Phase Of Power : Line (L)										
No	Frequency (MHz)	Correction Factor (dB)	Reading Value (dBuV)		Emission Level (dBuV)		Limit (dBuV)		Margin (dB)	
			Q.P.	AV.	Q.P.	AV.	Q.P.	AV.	Q.P.	AV.
1	0.15802	9.67	35.78	19.94	45.45	29.61	65.57	55.57	-20.12	-25.96
2	0.17346	9.67	33.45	18.12	43.12	27.79	64.79	54.79	-21.67	-27.00
3	0.18903	9.67	30.25	15.68	39.92	25.35	64.08	54.08	-24.16	-28.73
4	0.20031	9.67	28.37	14.34	38.04	24.01	63.60	53.60	-25.56	-29.59
5	0.25948	9.67	19.17	6.34	28.84	16.01	61.45	51.45	-32.61	-35.44
6	23.98927	9.91	21.22	8.32	31.13	18.23	60.00	50.00	-28.87	-31.77

Remarks:

1. Q.P. and AV. are abbreviations of quasi-peak and average individually.
2. The emission levels of other frequencies were very low against the limit.
3. Margin value = Emission level – Limit value
4. Correction factor = Insertion loss + Cable loss
5. Emission Level = Correction Factor + Reading Value

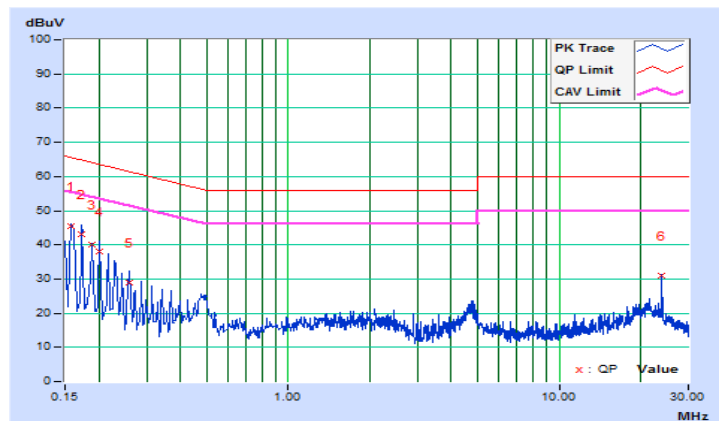

Frequency Range	150kHz ~ 30MHz	Detector Function & Resolution Bandwidth	Quasi-Peak (QP) / Average (AV), 9kHz
Input Power	120Vac, 60Hz	Environmental Conditions	25°C, 65%RH
Tested by	Jisyong Wang	Test Date	2018/9/9

Phase Of Power : Neutral (N)										
No	Frequency (MHz)	Correction Factor (dB)	Reading Value (dBuV)		Emission Level (dBuV)		Limit (dBuV)		Margin (dB)	
			Q.P.	AV.	Q.P.	AV.	Q.P.	AV.	Q.P.	AV.
1	0.15760	9.68	35.41	19.68	45.09	29.36	65.59	55.59	-20.50	-26.23
2	0.16967	9.68	33.68	18.47	43.36	28.15	64.98	54.98	-21.62	-26.83
3	0.19717	9.67	29.21	15.10	38.88	24.77	63.73	53.73	-24.85	-28.96
4	0.22434	9.67	24.28	11.05	33.95	20.72	62.66	52.66	-28.71	-31.94
5	0.25557	9.67	18.95	6.86	28.62	16.53	61.57	51.57	-32.95	-35.04
6	23.98927	10.03	21.03	6.92	31.06	16.95	60.00	50.00	-28.94	-33.05

Remarks:

1. Q.P. and AV. are abbreviations of quasi-peak and average individually.
2. The emission levels of other frequencies were very low against the limit.
3. Margin value = Emission level – Limit value
4. Correction factor = Insertion loss + Cable loss
5. Emission Level = Correction Factor + Reading Value

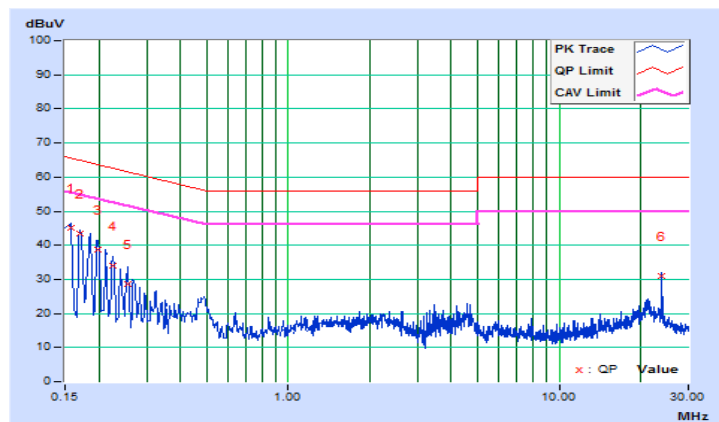

## 5 Pictures of Test Arrangements

Please refer to the attached file (Test Setup Photo).



### Annex A- Radiated Out of Band Emisison (OOBE) Measurement (For U-NII-3 band)

Mode A  
802.11a

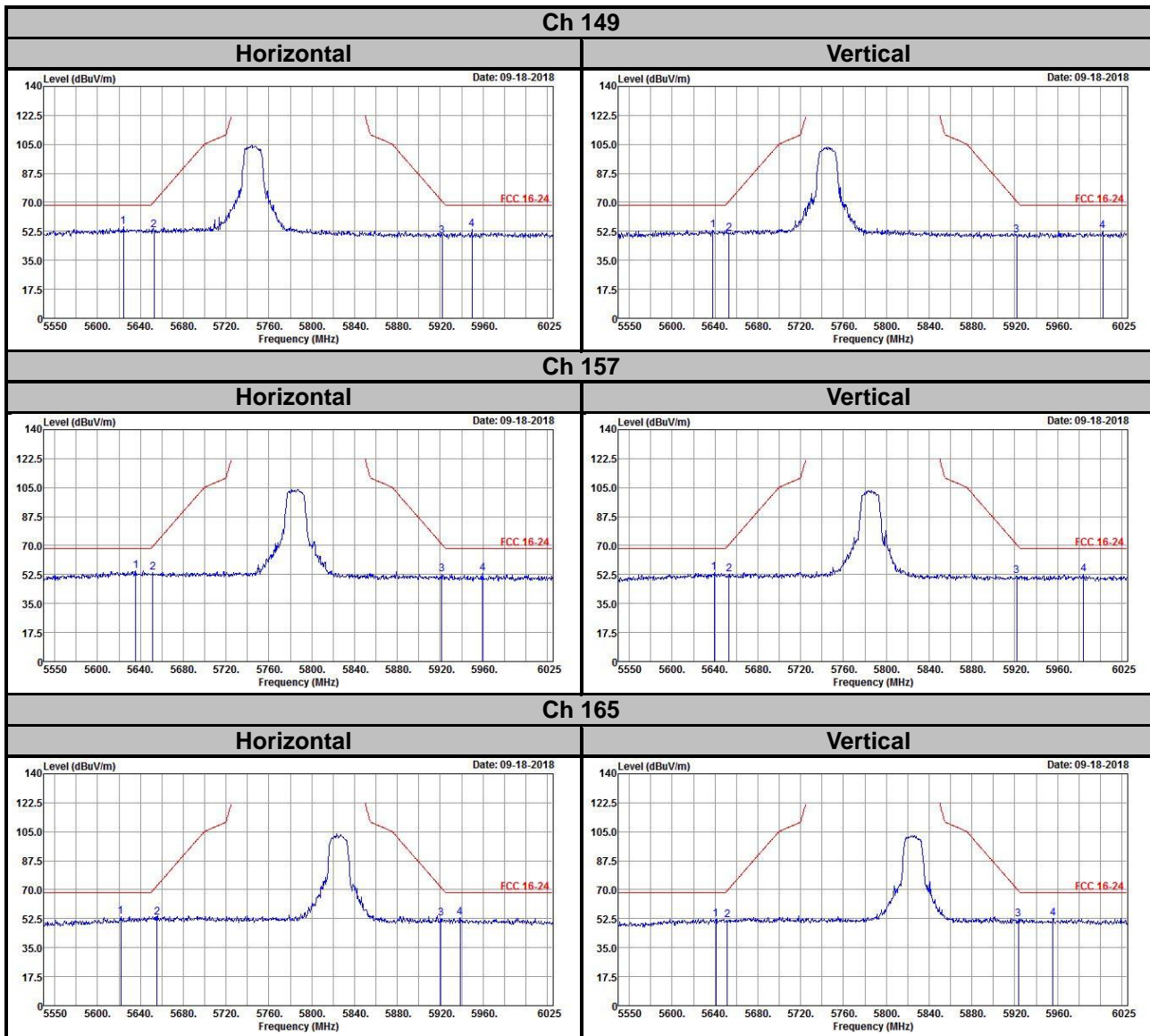

802.11n (HT20)

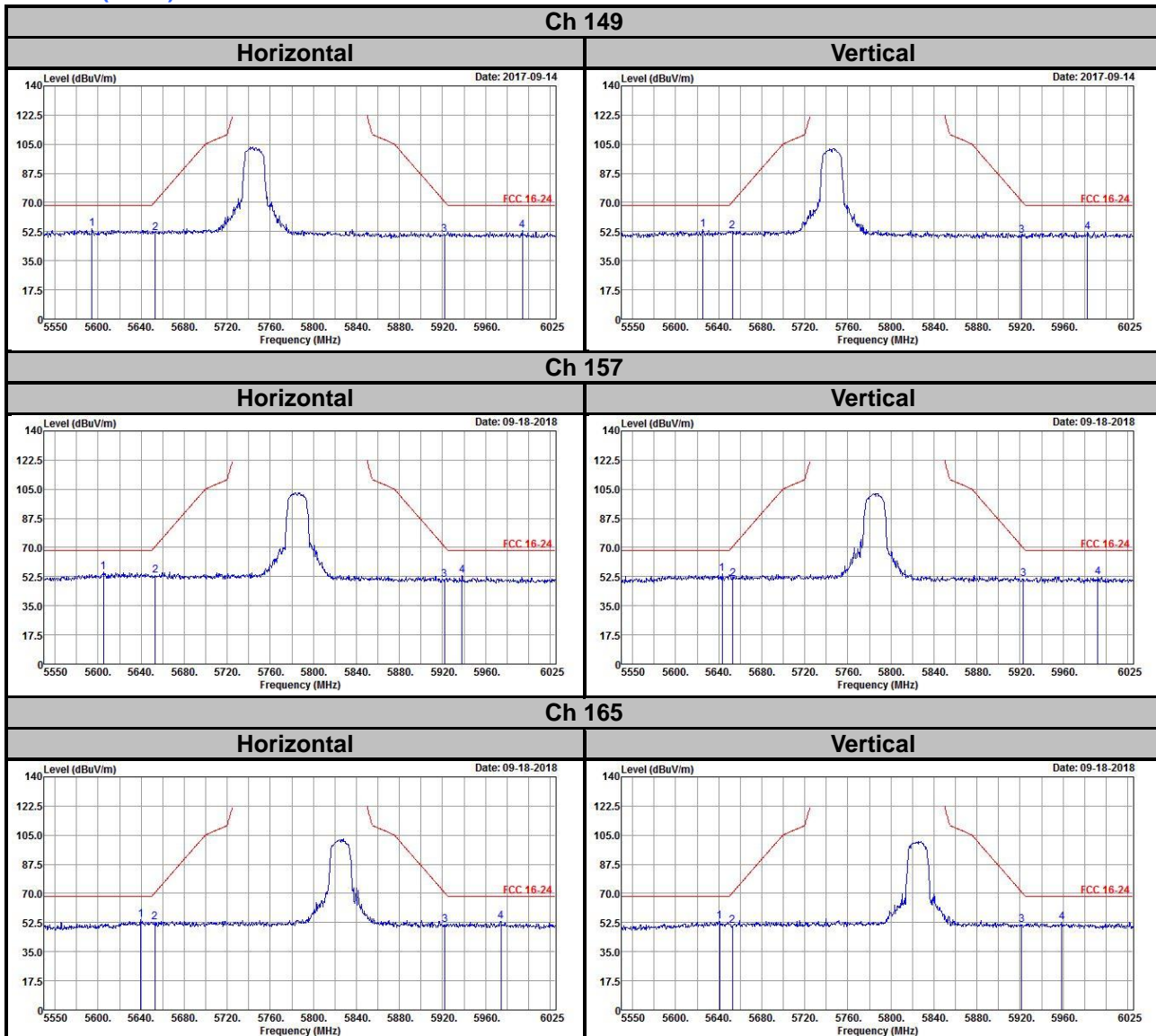

802.11n (HT40)

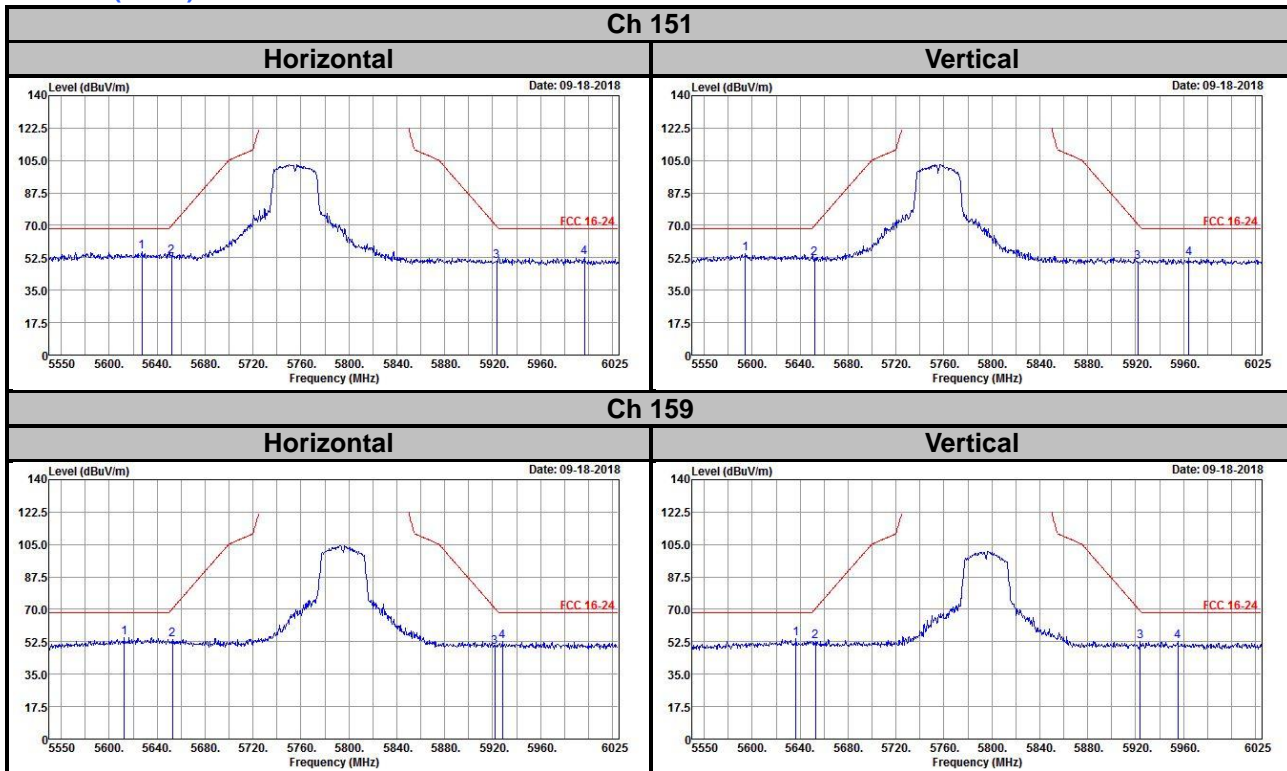

Mode B  
802.11a

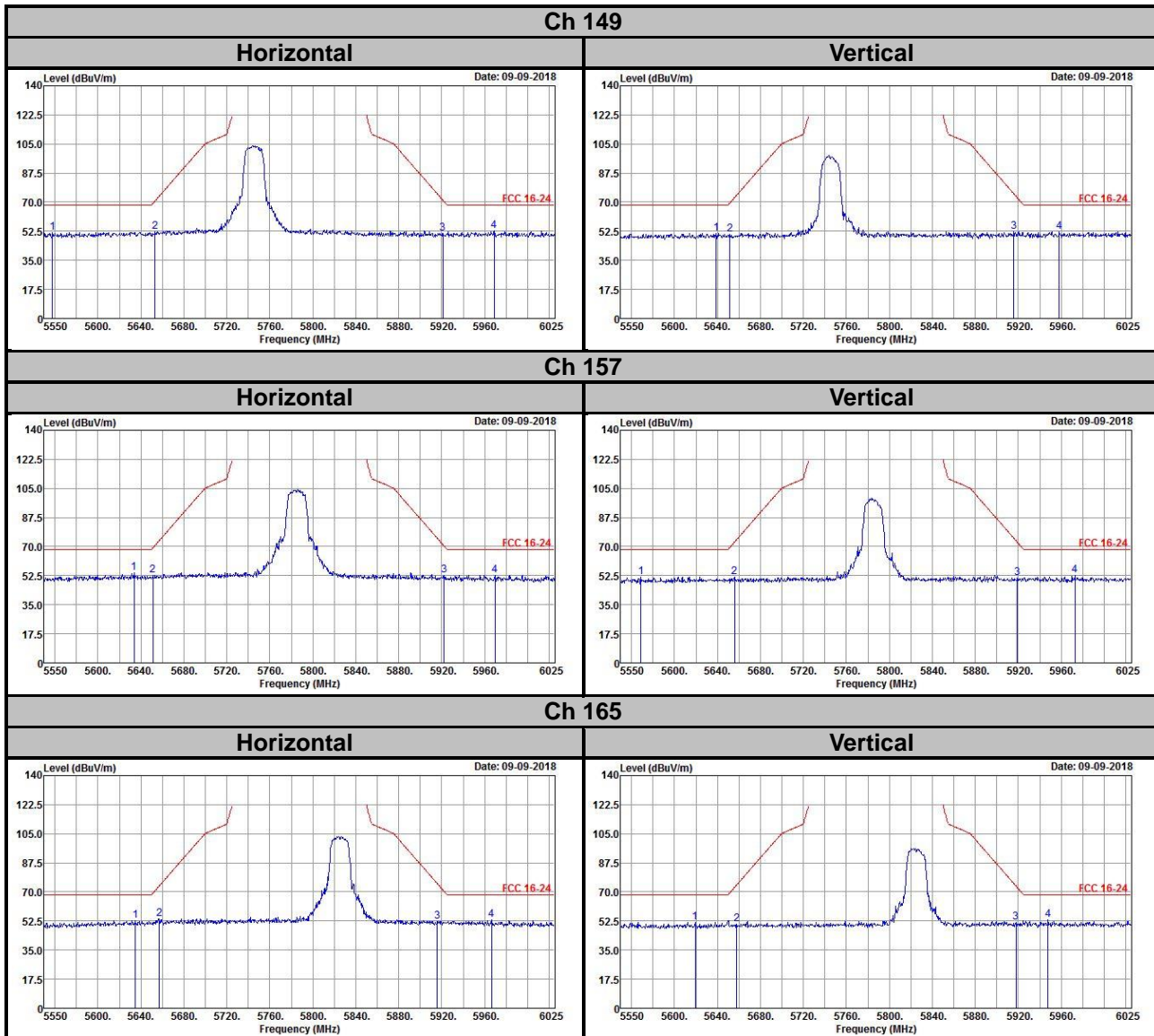

802.11n (HT20)

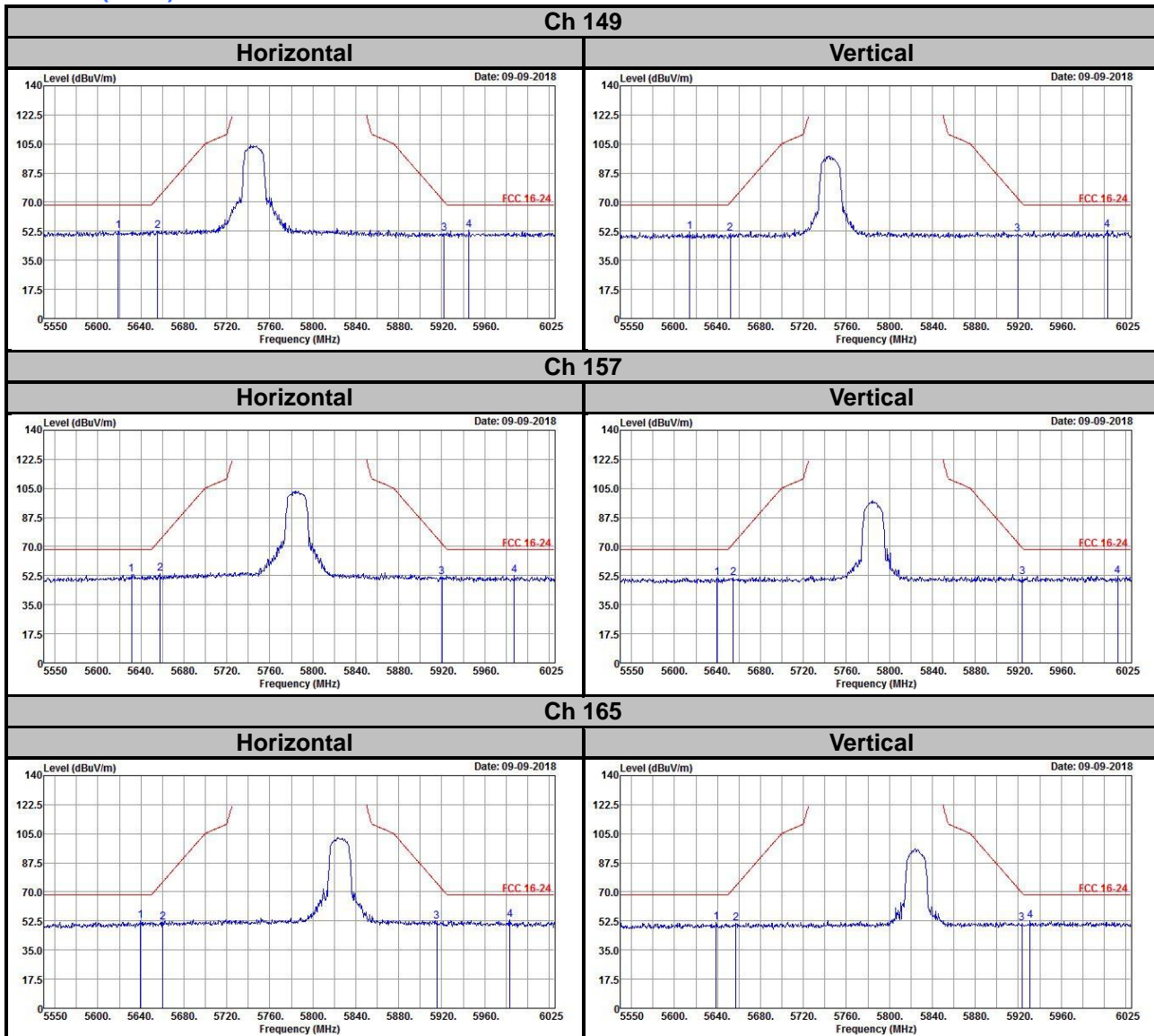

802.11n (HT40)

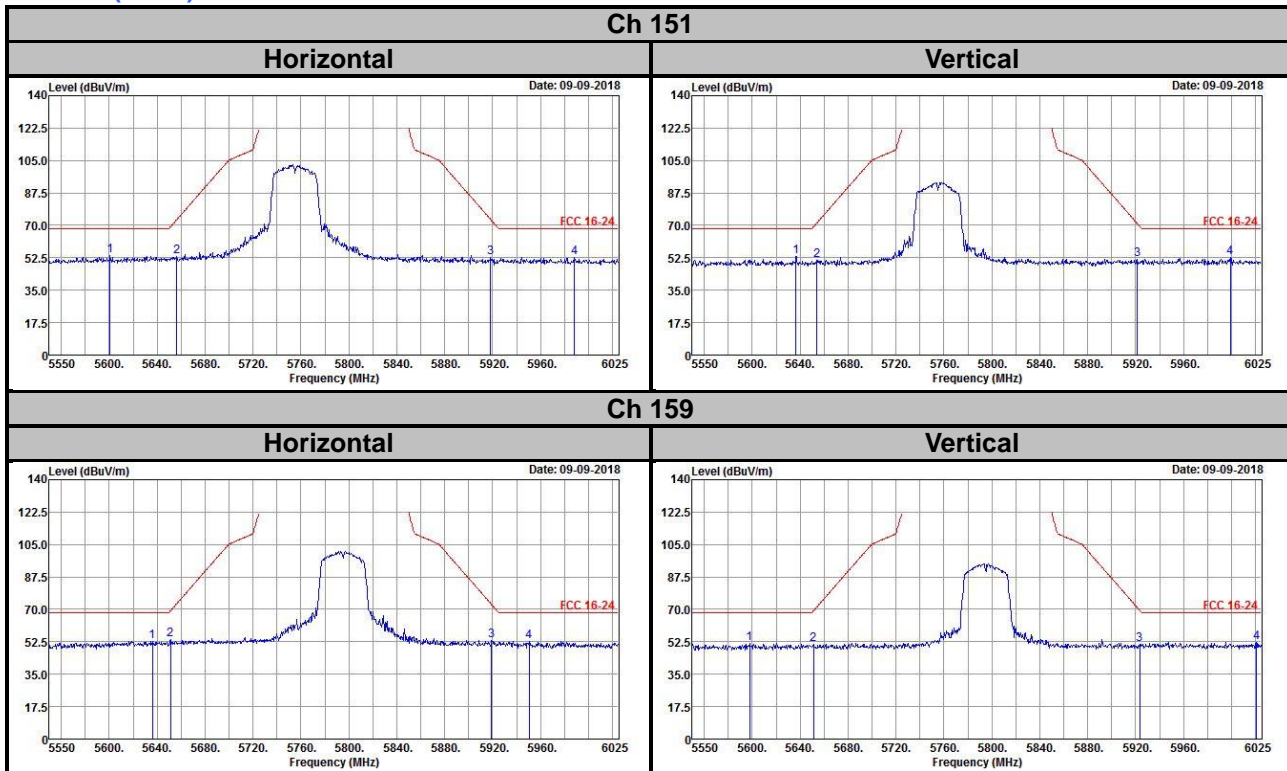

## Appendix – Information on the Testing Laboratories

We, Bureau Veritas Consumer Products Services (H.K.) Ltd., Taoyuan Branch, were founded in 1988 to provide our best service in EMC, Radio, Telecom and Safety consultation. Our laboratories are FCC recognized accredited test firms and accredited according to ISO/IEC 17025.

If you have any comments, please feel free to contact us at the following:

**Linko EMC/RF Lab**

Tel: 886-2-26052180

Fax: 886-2-26051924

**Hsin Chu EMC/RF/Telecom Lab**

Tel: 886-3-6668565

Fax: 886-3-6668323

**Hwa Ya EMC/RF/Safety**

Tel: 886-3-3183232

Fax: 886-3-3270892

**Email:** [service.adt@tw.bureauveritas.com](mailto:service.adt@tw.bureauveritas.com)

**Web Site:** [www.bureauveritas-adt.com](http://www.bureauveritas-adt.com)

The address and road map of all our labs can be found in our web site also.

--- END ---