

FCC Test Report

Report No.: RF170818C25-1

FCC ID: 2ADWC-AI7697HD

Test Model: AI7697HD

Received Date: Aug. 18, 2017

Test Date: Sep. 12, 2017 ~ Sep. 18, 2017

Issued Date: Oct. 06, 2017

Applicant: AcSiP Technology Corporation

Address: 3F.-1, No.207, Fusing Rd., Taoyuan Dist., Taoyuan County 330, Taiwan
(R.O.C.)

Issued By: Bureau Veritas Consumer Products Services (H.K.) Ltd., Taoyuan Branch

Lab Address: No. 47-2, 14th Ling, Chia Pau Vil., Lin Kou Dist., New Taipei City, Taiwan
(R.O.C)

Test Location: No. 19, Hwa Ya 2nd Rd, Wen Hwa Tsuen, Kwei Shan Hsiang, Taoyuan
Hsien 333, Taiwan, R.O.C.



This report is for your exclusive use. Any copying or replication of this report to or for any other person or entity, or use of our name or trademark, is permitted only with our prior written permission. This report sets forth our findings solely with respect to the test samples identified herein. The results set forth in this report are not indicative or representative of the quality or characteristics of the lot from which a test sample was taken or any similar or identical product unless specifically and expressly noted. Our report includes all of the tests requested by you and the results thereof based upon the information that you provided to us. You have 60 days from date of issuance of this report to notify us of any material error or omission caused by our negligence, provided, however, that such notice shall be in writing and shall specifically address the issue you wish to raise. A failure to raise such issue within the prescribed time shall constitute your unqualified acceptance of the completeness of this report, the tests conducted and the correctness of the report contents. Unless specifically mentioned, the uncertainty of measurement has been explicitly taken into account to declare the compliance or non-compliance to the specification.

Table of Contents

Release Control Record	4
1 Certificate of Conformity	5
2 Summary of Test Results	6
2.1 Measurement Uncertainty.....	6
2.2 Modification Record	6
3 General Information	7
3.1 General Description of EUT	7
3.2 Description of Test Modes.....	8
3.2.1 Test Mode Applicability and Tested Channel Detail.....	9
3.3 Duty Cycle of Test Signal	11
3.4 Description of Support Units	12
3.4.1 Configuration of System under Test	12
3.5 General Description of Applied Standards.....	12
4 Test Types and Results	13
4.1 Radiated Emission and Bandedge Measurement	13
4.1.1 Limits of Radiated Emission and Bandedge Measurement	13
4.1.2 Test Instruments	14
4.1.3 Test Procedures.....	16
4.1.4 Deviation from Test Standard	16
4.1.5 Test Set Up	17
4.1.6 EUT Operating Conditions.....	18
4.1.7 Test Results	19
4.2 Conducted Emission Measurement.....	32
4.2.1 Limits of Conducted Emission Measurement	32
4.2.2 Test Instruments	32
4.2.3 Test Procedures.....	33
4.2.4 Deviation from Test Standard	33
4.2.5 Test Setup.....	33
4.2.6 EUT Operating Conditions.....	33
4.2.7 Test Results	34
4.3 6 dB Bandwidth Measurement.....	36
4.3.1 Limits of 6 dB Bandwidth Measurement.....	36
4.3.2 Test Setup.....	36
4.3.3 Test Instruments	36
4.3.4 Test Procedure	36
4.3.5 Deviation from Test Standard	36
4.3.6 EUT Operating Conditions.....	36
4.3.7 Test Result	37
4.4 Occupied Bandwidth Measurement.....	39
4.4.1 Test Setup.....	39
4.4.2 Test Instruments	39
4.4.3 Test Procedure	39
4.4.4 Deviation from Test Standard	39
4.4.5 EUT Operating Conditions.....	39
4.4.6 Test Results	40
4.5 Conducted Output Power Measurement	42
4.5.1 Limits of Conducted Output Power Measurement.....	42
4.5.2 Test Setup.....	42
4.5.3 Test Instruments	42
4.5.4 Test Procedures.....	42
4.5.5 Deviation from Test Standard	42
4.5.6 EUT Operating Conditions.....	42
4.5.7 Test Results	43

4.6	Power Spectral Density Measurement	44
4.6.1	Limits of Power Spectral Density Measurement.....	44
4.6.2	Test Setup.....	44
4.6.3	Test Instruments	44
4.6.4	Test Procedure	44
4.6.5	Deviation from Test Standard	44
4.6.6	EUT Operating Condition	44
4.6.7	Test Results	45
4.7	Conducted Out of Band Emission Measurement	47
4.7.1	Limits of Conducted Out of Band Emission Measurement.....	47
4.7.2	Test Setup.....	47
4.7.3	Test Instruments	47
4.7.4	Test Procedure	47
4.7.5	Deviation from Test Standard	47
4.7.6	EUT Operating Condition	47
4.7.7	Test Results	48
5	Pictures of Test Arrangements.....	56
	Appendix – Information on the Testing Laboratories	57

Release Control Record

Issue No.	Description	Date Issued
RF170818C25-1	Original Release	Oct. 06, 2017

1 Certificate of Conformity

Product: 802.11 IoT Module

Brand: AcSiP

Test Model: AI7697HD

Sample Status: Production Unit

Applicant: AcSiP Technology Corporation

Test Date: Sep. 12, 2017 ~ Sep. 18, 2017

Standards: 47 CFR FCC Part 15, Subpart C (Section 15.247)
ANSI C63.10:2013

The above equipment has been tested by **Bureau Veritas Consumer Products Services (H.K.) Ltd., Taoyuan Branch**, and found compliance with the requirement of the above standards. The test record, data evaluation & Equipment Under Test (EUT) configurations represented herein are true and accurate accounts of the measurements of the sample's EMC characteristics under the conditions specified in this report.

Prepared by : Evonne Liu , **Date:** Oct. 06, 2017
Evonne Liu / Specialist

Approved by : David Huang , **Date:** Oct. 06, 2017
David Huang / Project Engineer

2 Summary of Test Results

47 CFR FCC Part 15, Subpart C (Section 15.247)			
FCC Clause	Test Item	Result	Remarks
15.207	AC Power Conducted Emission	Pass	Meet the requirement of limit. Minimum passing margin is -19.81 dB at 0.15400 MHz.
15.205 / 15.209 / 15.247(d)	Radiated Emissions and Band Edge Measurement	Pass	Meet the requirement of limit. Minimum passing margin is -0.53 dB at 2484.44 MHz.
15.247(d)	Antenna Port Emission	Pass	Meet the requirement of limit.
15.247(a)(2)	6 dB Bandwidth	Pass	Meet the requirement of limit.
---	Occupied Bandwidth Measurement	Pass	Reference only
15.247(b)	Conducted power	Pass	Meet the requirement of limit.
15.247(e)	Power Spectral Density	Pass	Meet the requirement of limit.
15.203	Antenna Requirement	Pass	No antenna connector is used.

2.1 Measurement Uncertainty

Where relevant, the following measurement uncertainty levels have been estimated for tests performed on the EUT:

The listed uncertainties are the worst case uncertainty for the entire range of measurement. Please note that the uncertainty values are provided for informational purposes only and are not used in determining the PASS/FAIL results.

Measurement	Frequency	Expanded Uncertainty (k=2) (\pm)
Conducted Emissions at mains ports	150 kHz ~ 30 MHz	2.44 dB
Radiated Emissions up to 1 GHz	30 MHz ~ 200 MHz	2.93 dB
	200 MHz ~ 1000 MHz	2.95 dB
Radiated Emissions above 1 GHz	1 GHz ~ 18 GHz	2.26 dB
	18 GHz ~ 40 GHz	1.94 dB

2.2 Modification Record

There were no modifications required for compliance.

3 General Information

3.1 General Description of EUT

Product	802.11 IoT Module
Brand	AcSiP
Test Model	AI7697HD
Status of EUT	Production Unit
Power Supply Rating	5.0 Vdc (host equipment)
Modulation Type	CCK, DQPSK, DBPSK for DSSS 64QAM, 16QAM, QPSK, BPSK for OFDM
Modulation Technology	DSSS, OFDM
Transfer Rate	802.11b: 11.0 / 5.5 / 2.0 / 1.0 Mbps 802.11g: 54.0 / 48.0 / 36.0 / 24.0 / 18.0 / 12.0 / 9.0 / 6.0 Mbps 802.11n: up to MCS7
Operating Frequency	2412 ~ 2462 MHz
Number of Channel	11 for 802.11b, 802.11g, 802.11n (HT20) 7 for 802.11n (HT40)
Output Power	281.19 mW
Antenna Type	PIFA antenna with 3.34 dBi gain
Antenna Connector	N/A
Accessory Device	N/A
Data Cable Supplied	N/A

Note:

1. The above EUT information is declared by manufacturer and for more detailed features description, please refer to the manufacturer's specifications or user's manual.

3.2 Description of Test Modes

11 channels are provided for 802.11b, 802.11g and 802.11n (HT20):

Channel	Frequency (MHz)	Channel	Frequency (MHz)
1	2412	7	2442
2	2417	8	2447
3	2422	9	2452
4	2427	10	2457
5	2432	11	2462
6	2437		

7 channels are provided for 802.11n (HT40):

Channel	Frequency (MHz)	Channel	Frequency (MHz)
3	2422	7	2442
4	2427	8	2447
5	2432	9	2452
6	2437		

3.2.1 Test Mode Applicability and Tested Channel Detail

EUT Configure Mode	Applicable To				Description
	RE \geq 1G	RE<1G	PLC	APCM	
-	√	√	√	√	-

Where **RE \geq 1G**: Radiated Emission above 1 GHz **RE<1G**: Radiated Emission below 1 GHz
PLC: Power Line Conducted Emission **APCM**: Antenna Port Conducted Measurement

NOTE: The EUT had been pre-tested on the positioned of each 3 axis. The worst case was found when positioned on **Y-plane**.

Radiated Emission Test (Above 1 GHz):

- Pre-Scan has been conducted to determine the worst-case mode from all possible combinations between available modulations, data rates and antenna ports (if EUT with antenna diversity architecture).
- Following channel(s) was (were) selected for the final test as listed below.

EUT Configure Mode	Mode	Available Channel	Tested Channel	Modulation Technology	Modulation Type	Data Rate (Mbps)
-	802.11b	1 to 11	1, 6, 11	DSSS	DBPSK	1.0
-	802.11g	1 to 11	1, 6, 11	OFDM	BPSK	6.0
-	802.11n (HT20)	1 to 11	1, 6, 11	OFDM	BPSK	MCS0
-	802.11n (HT40)	3 to 9	3, 6, 9	OFDM	BPSK	MCS0

Radiated Emission Test (Below 1 GHz):

- Pre-Scan has been conducted to determine the worst-case mode from all possible combinations between available modulations, data rates and antenna ports (if EUT with antenna diversity architecture).
- Following channel(s) was (were) selected for the final test as listed below.

EUT Configure Mode	Mode	Available Channel	Tested Channel	Modulation Technology	Modulation Type	Data Rate (Mbps)
-	802.11n (HT40)	1 to 11	9	OFDM	BPSK	MCS0

Power Line Conducted Emission Test:

- Pre-Scan has been conducted to determine the worst-case mode from all possible combinations between available modulations, data rates and antenna ports (if EUT with antenna diversity architecture).
- Following channel(s) was (were) selected for the final test as listed below.

EUT Configure Mode	Mode	Available Channel	Tested Channel	Modulation Technology	Modulation Type	Data Rate (Mbps)
-	802.11n (HT40)	1 to 11	9	OFDM	BPSK	MCS0

Bandedge Measurement:

- Pre-Scan has been conducted to determine the worst-case mode from all possible combinations between available modulations, data rates and antenna ports (if EUT with antenna diversity architecture).
- Following channel(s) was (were) selected for the final test as listed below.

EUT Configure Mode	Mode	Available Channel	Tested Channel	Modulation Technology	Modulation Type	Data Rate (Mbps)
-	802.11b	1 to 11	1, 11	DSSS	DBPSK	1.0
-	802.11g	1 to 11	1, 11	OFDM	BPSK	6.0
-	802.11n (HT20)	1 to 11	1, 11	OFDM	BPSK	MCS0
-	802.11n (HT40)	3 to 9	3, 9	OFDM	BPSK	MCS0

Antenna Port Conducted Measurement:

- This item includes all test value of each mode, but only includes spectrum plot of worst value of each mode.
- Pre-Scan has been conducted to determine the worst-case mode from all possible combinations between available modulations, data rates and antenna ports (if EUT with antenna diversity architecture).
- Following channel(s) was (were) selected for the final test as listed below.

EUT Configure Mode	Mode	Available Channel	Tested Channel	Modulation Technology	Modulation Type	Data Rate (Mbps)
-	802.11b	1 to 11	1, 6, 11	DSSS	DBPSK	1.0
-	802.11g	1 to 11	1, 6, 11	OFDM	BPSK	6.0
-	802.11n (HT20)	1 to 11	1, 6, 11	OFDM	BPSK	MCS0
-	802.11n (HT40)	3 to 9	3, 6, 9	OFDM	BPSK	MCS0

Test Condition:

Applicable To	Environmental Conditions	Input Power	Tested by
RE \geq 1G	25 deg. C, 65 % RH	120 Vac, 60 Hz	Gavin Wu
RE<1G	25 deg. C, 65 % RH	120 Vac, 60 Hz	Gavin Wu
PLC	25 deg. C, 65 % RH	120 Vac, 60 Hz	Getaz Yang
APCM	25 deg. C, 65 % RH	120 Vac, 60 Hz	Carlos Chen

3.3 Duty Cycle of Test Signal

802.11b / 802.11g / 802.11n (HT20) / 802.11n (HT40):

Duty cycle of test signal is 100 %, duty factor is not required.

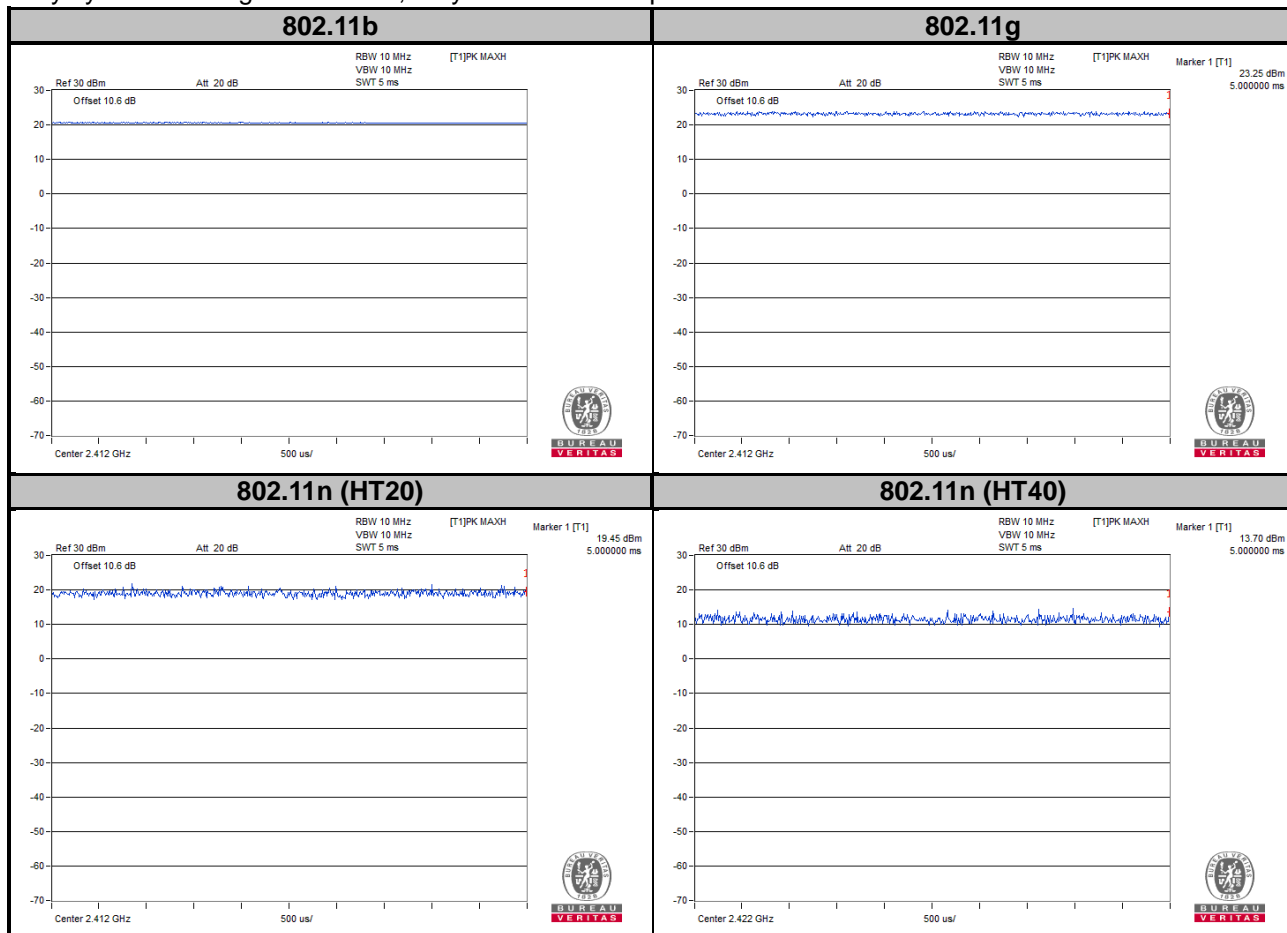

3.4 Description of Support Units

The EUT has been tested as an independent unit together with other necessary accessories or support units. The following support units or accessories were used to form a representative test configuration during the tests.

No.	Product	Brand	Model No.	Serial No.	FCC ID
1.	NB	N/A	N/A	N/A	N/A

No.	Signal Cable Description Of The Above Support Units
1.	N/A

Note:

1. All power cords of the above support units are non-shielded (1.8m).

3.4.1 Configuration of System under Test

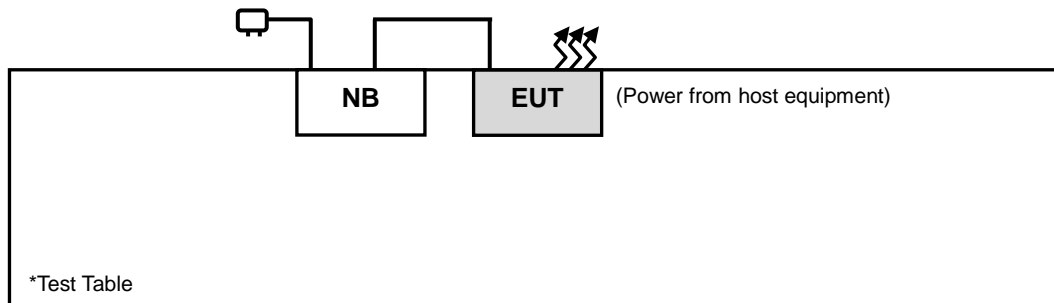

3.5 General Description of Applied Standards

The EUT is a RF Product. According to the specifications of the manufacturer, it must comply with the requirements of the following standards:

FCC Part 15, Subpart C (15.247)
558074 D01 DTS Meas Guidance v04
 ANSI C63.10-2013

All test items have been performed and recorded as per the above standards.

NOTE: The EUT has been verified to comply with the requirements of FCC Part 15, Subpart B, Class B (DoC). The test report has been issued separately.

4 Test Types and Results

4.1 Radiated Emission and Bandedge Measurement

4.1.1 Limits of Radiated Emission and Bandedge Measurement

Radiated emissions which fall in the restricted bands must comply with the radiated emission limits specified as below table. Other emissions shall be at least 20 dB below the highest level of the desired power:

Frequencies (MHz)	Field Strength (microvolts/meter)	Measurement Distance (meters)
0.009 ~ 0.490	2400/F (kHz)	300
0.490 ~ 1.705	24000/F (kHz)	30
1.705 ~ 30.0	30	30
30 ~ 88	100	3
88 ~ 216	150	3
216 ~ 960	200	3
Above 960	500	3

NOTE:

1. The lower limit shall apply at the transition frequencies.
2. Emission level (dBuV/m) = 20 log Emission level (uV/m).
3. For frequencies above 1000 MHz, the field strength limits are based on average detector, however, the peak field strength of any emission shall not exceed the maximum permitted average limits, specified above by more than 20 dB under any condition of modulation.

4.1.2 Test Instruments

Description & Manufacturer	Model No.	Serial No.	Date of Calibration	Due Date of Calibration
Test Receiver Agilent	N9038A	MY51210203	Feb. 17, 2017	Feb. 16, 2018
Spectrum Analyzer Agilent	N9010A	MY52220314	Dec. 16, 2016	Dec. 15, 2017
Spectrum Analyzer ROHDE & SCHWARZ	FSU43	101261	Dec. 13, 2016	Dec. 12, 2017
BILOG Antenna SCHWARZBECK	VULB9168	9168-472	Dec. 26, 2016	Dec. 27, 2017
HORN Antenna SCHWARZBECK	BBHA 9120 D	9120D-969	Dec. 12, 2016	Dec. 13, 2017
HORN Antenna SCHWARZBECK	BBHA 9170	9170-480	Dec. 14, 2016	Dec. 13, 2017
Fixed Attenuator Mini-Circuits	MDCS18N-10	MDCS18N-10-01	Apr. 17, 2017	Apr. 16, 2018
Loop Antenna	HLA 6121	45745	May 19, 2017	May 18, 2018
Preamplifier EMCI	EMC001340	980201	Nov. 02, 2016	Nov. 01, 2017
Bluetooth Tester	CBT	100946	Jul. 29, 2016	Jul. 28, 2018
Preamplifier EMCI	EMC 012645	980115	Oct. 21, 2016	Oct. 20, 2017
Preamplifier EMCI	EMC 184045	980116	Oct. 21, 2016	Oct. 20, 2017
Preamplifier EMCI	EMC 330H	980112	Oct. 21, 2016	Oct. 20, 2017
Power Meter Anritsu	ML2495A	1145013	Mar. 07, 2017	Mar. 06, 2018
Power Sensor Anritsu	MA2411B	1126085	Mar. 07, 2017	Mar. 06, 2018
RF signal cable HUBER+SUHNNER	SUCOFLEX 104	309219/4 2950114	Oct. 21, 2016	Oct. 20, 2017
RF signal cable HUBER+SUHNNER	SUCOFLEX 104	250130/4	Oct. 21, 2016	Oct. 20, 2017
RF Coaxial Cable Worken	8D-FB	Cable-Ch10-01	Oct. 21, 2016	Oct. 20, 2017
Software BV ADT	E3 6.120103	NA	NA	NA
Antenna Tower MF	MFA-440H	NA	NA	NA
Turn Table MF	MFT-201SS	NA	NA	NA
Antenna Tower & Turn Table Controller MF	MF-7802	NA	NA	NA

- Note:
1. The calibration interval of the above test instruments is 12 months and the calibrations are traceable to NML/ROC and NIST/USA.
 2. The test was performed in HwaYa Chamber 10.
 3. The horn antenna and preamplifier (model: EMC 184045) are used only for the measurement of emission frequency above 1 GHz if tested.
 4. The FCC Designation Number is TW0003. The number will be varied with the Lab location and scope as attached.
 5. The IC Site Registration No. is IC7450F-10.

4.1.3 Test Procedures

- a. The EUT was placed on the top of a rotating table 0.8 meters (for below 1 GHz) / 1.5 meters (for above 1 GHz) above the ground at 3 meter chamber room for test. The table was rotated 360 degrees to determine the position of the highest radiation.
- b. The EUT was set 3 meters away from the interference-receiving antenna, which was mounted on the top of a variable-height antenna tower.
- c. The height of antenna is varied from one meter to four meters above the ground to determine the maximum value of the field strength. Both horizontal and vertical polarizations of the antenna are set to make the measurement.
- d. For each suspected emission, the EUT was arranged to its worst case and then the antenna was tuned to heights from 1 meter to 4 meters and the rotatable table was turned from 0 degrees to 360 degrees to find the maximum reading.
- e. The test-receiver system was set to quasi-peak detect function and specified bandwidth with maximum hold mode when the test frequency is below 1 GHz.
- f. The test-receiver system was set to peak and average detected function and specified bandwidth with maximum hold mode when the test frequency is above 1 GHz. If the peak reading value also meets average limit, measurement with the average detector is unnecessary.

Note:

1. The resolution bandwidth and video bandwidth of test receiver/spectrum analyzer is 120 kHz & 360 KHz for Quasi-peak detection (QP) at frequency below 1 GHz.
2. The resolution bandwidth of test receiver/spectrum analyzer is 1 MHz and the video bandwidth is 3 MHz for Peak detection (PK) at frequency above 1 GHz.
3. The resolution bandwidth of test receiver/spectrum analyzer is 1 MHz and the video bandwidth is 1/T for Average (Duty cycle < 98 %) detection at frequency above 1 GHz.
4. The resolution bandwidth of test receiver/spectrum analyzer is 1 MHz and the video bandwidth is 10 Hz (Duty cycle \geq 98 %) for Average detection (AV) at frequency above 1 GHz.
5. All modes of operation were investigated and the worst-case emissions are reported.

4.1.4 Deviation from Test Standard

No deviation.

4.1.5 Test Set Up

<Radiated emission below 30 MHz>

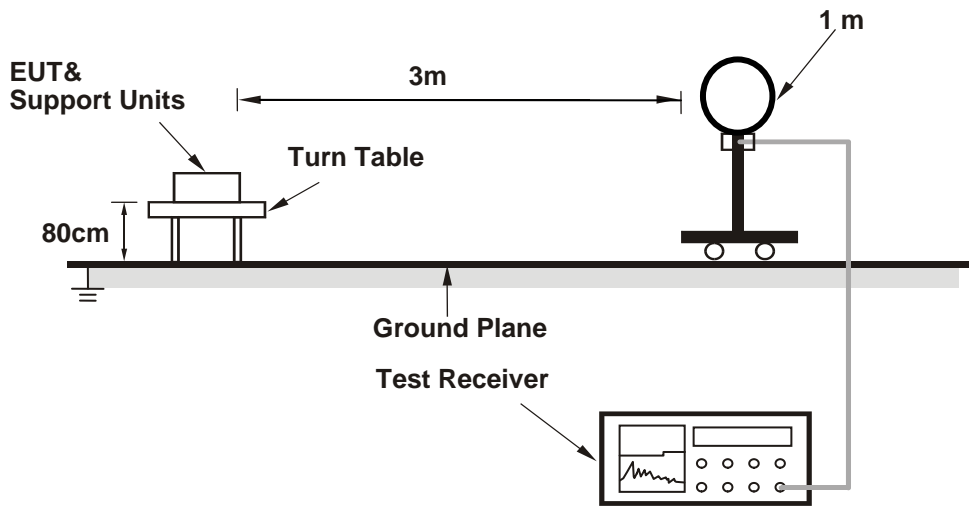

<Frequency Range below 1 GHz>

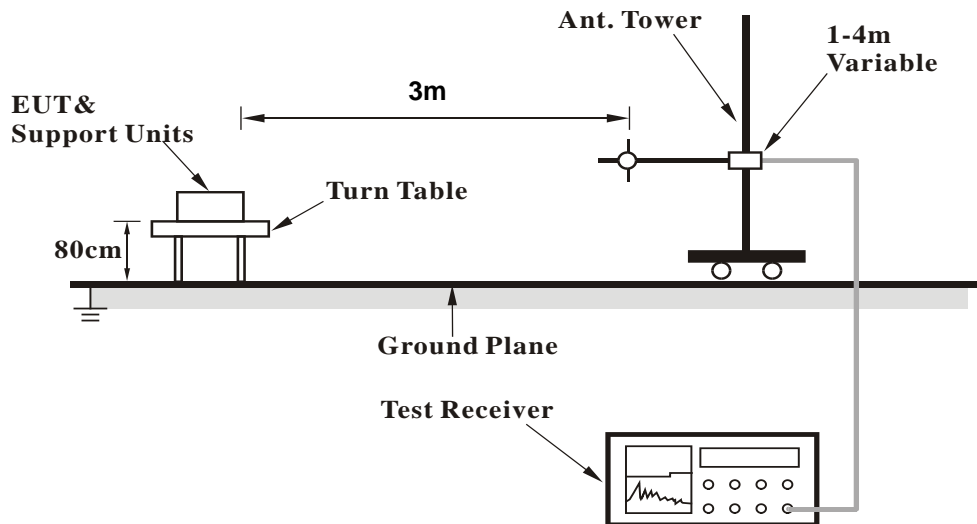

<Frequency Range above 1 GHz>

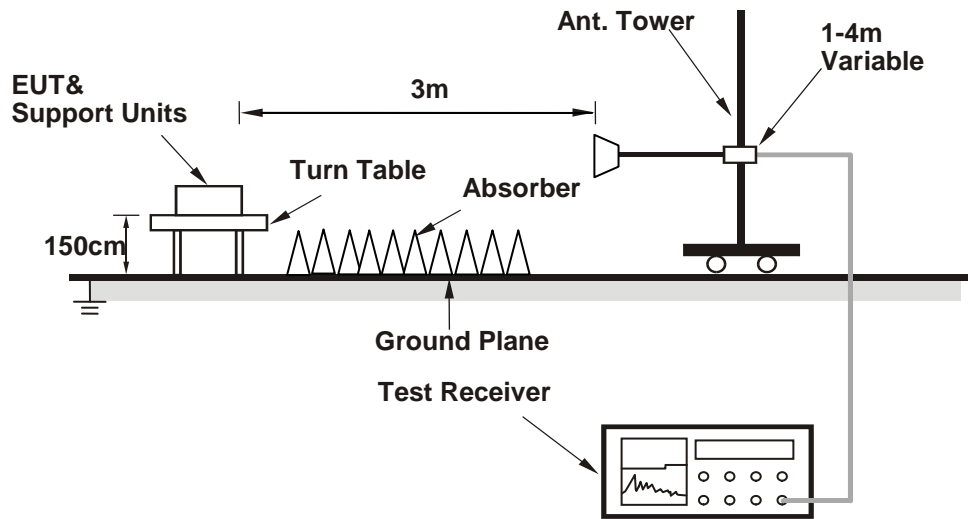

For the actual test configuration, please refer to the attached file (Test Setup Photo).

4.1.6 EUT Operating Conditions

- a. Placed the EUT on a testing table.
- b. Use the software to control the EUT under transmission condition continuously at specific channel frequency.

4.1.7 Test Results

Above 1 GHz Data :
802.11b

EUT Test Condition		Measurement Detail	
Channel	Channel 1	Frequency Range	1 GHz ~ 25 GHz
Input Power	120 Vac, 60 Hz	Detector Function	Peak (PK) Average (AV)
Environmental Conditions	25 deg. C, 65 % RH	Tested By	Gavin Wu

Antenna Polarity & Test Distance: Horizontal at 3 m										
Frequency (MHz)	Emission Level (dBuV/m)	Read Level (dBuV)	Limit (dBuV/m)	Margin (dB)	Antenna Factor (dB/m)	Cable Loss (dB)	Preamp Factor (dB)	Antenna Height (cm)	Table Angle (Degree)	Remark
2386.32	52.94	75.06	54	-1.06	26.91	4.84	53.87	167	236	Average
2386.32	60.2	66.44	74	-13.8	26.91	4.35	37.5	167	236	Peak
2412	103.28	109.46			26.96	4.38	37.52	167	236	Average
2412	107.16	113.34			26.96	4.38	37.52	167	236	Peak
4824	45.54	60.63	54	-8.46	30.99	6.81	52.89	100	30	Average
4824	49.48	64.57	74	-24.52	30.99	6.81	52.89	100	30	Peak

Antenna Polarity & Test Distance: Vertical at 3 m										
Frequency (MHz)	Emission Level (dBuV/m)	Read Level (dBuV)	Limit (dBuV/m)	Margin (dB)	Antenna Factor (dB/m)	Cable Loss (dB)	Preamp Factor (dB)	Antenna Height (cm)	Table Angle (Degree)	Remark
2386.14	47.26	69.38	54	-6.74	26.91	4.84	53.87	100	86	Average
2386.14	55.19	61.43	74	-18.81	26.91	4.35	37.5	100	86	Peak
2412	99.94	106.12			26.96	4.38	37.52	100	86	Average
2412	103.82	110			26.96	4.38	37.52	100	86	Peak
4824	41.28	56.37	54	-12.72	30.99	6.81	52.89	100	276	Average
4824	47.68	62.77	74	-26.32	30.99	6.81	52.89	100	276	Peak

Remarks:

- Emission Level = Read Level + Antenna Factor + Cable Loss - Preamp Factor
Margin value = Emission level – Limit value
- 2412 MHz: Fundamental frequency.

EUT Test Condition		Measurement Detail	
Channel	Channel 6	Frequency Range	1 GHz ~ 25 GHz
Input Power	120 Vac, 60 Hz	Detector Function	Peak (PK) Average (AV)
Environmental Conditions	25 deg. C, 65 % RH	Tested By	Gavin Wu

Antenna Polarity & Test Distance: Horizontal at 3 m										
Frequency (MHz)	Emission Level (dBuV/m)	Read Level (dBuV)	Limit (dBuV/m)	Margin (dB)	Antenna Factor (dB/m)	Cable Loss (dB)	Preamp Factor (dB)	Antenna Height (cm)	Table Angle (Degree)	Remark
2386.86	37.76	59.88	54	-16.24	26.91	4.84	53.87	183	238	Average
2386.86	51.15	57.38	74	-22.85	26.91	4.36	37.5	183	238	Peak
2437	101.57	107.57			27.06	4.4	37.46	183	238	Average
2437	105.48	111.48			27.06	4.4	37.46	183	238	Peak
2484.56	36.64	58.51	54	-17.36	27.15	4.94	53.96	183	238	Average
2484.56	49.71	55.45	74	-24.29	27.15	4.43	37.32	183	238	Peak
4874	42.53	57.47	54	-11.47	31.06	6.86	52.86	100	51	Average
4874	46.99	61.93	74	-27.01	31.06	6.86	52.86	100	51	Peak
Antenna Polarity & Test Distance: Vertical at 3 m										
Frequency (MHz)	Emission Level (dBuV/m)	Read Level (dBuV)	Limit (dBuV/m)	Margin (dB)	Antenna Factor (dB/m)	Cable Loss (dB)	Preamp Factor (dB)	Antenna Height (cm)	Table Angle (Degree)	Remark
2386.68	36.15	58.27	54	-17.85	26.91	4.84	53.87	100	87	Average
2386.68	49.4	55.63	74	-24.6	26.91	4.36	37.5	100	87	Peak
2437	99.52	105.52			27.06	4.4	37.46	100	87	Average
2437	103.42	109.42			27.06	4.4	37.46	100	87	Peak
2488.32	35.51	57.33	54	-18.49	27.2	4.94	53.96	100	87	Average
2488.32	48.72	54.41	74	-25.28	27.2	4.43	37.32	100	87	Peak
4874	37.66	52.6	54	-16.34	31.06	6.86	52.86	100	258	Average
4874	44.5	59.44	74	-29.5	31.06	6.86	52.86	100	258	Peak

Remarks:

- Emission Level = Read Level + Antenna Factor + Cable Loss - Preamp Factor
Margin value = Emission level – Limit value
- 2437 MHz: Fundamental frequency.

EUT Test Condition		Measurement Detail	
Channel	Channel 11	Frequency Range	1 GHz ~ 25 GHz
Input Power	120 Vac, 60 Hz	Detector Function	Peak (PK) Average (AV)
Environmental Conditions	25 deg. C, 65 % RH	Tested By	Gavin Wu

Antenna Polarity & Test Distance: Horizontal at 3 m										
Frequency (MHz)	Emission Level (dBuV/m)	Read Level (dBuV)	Limit (dBuV/m)	Margin (dB)	Antenna Factor (dB/m)	Cable Loss (dB)	Preamp Factor (dB)	Antenna Height (cm)	Table Angle (Degree)	Remark
2462	102.1	107.98			27.1	4.41	37.39	180	236	Average
2462	105.92	111.8			27.1	4.41	37.39	180	236	Peak
2483.92	40.69	62.56	54	-13.31	27.15	4.94	53.96	180	236	Average
2483.92	53.04	58.78	74	-20.96	27.15	4.43	37.32	180	236	Peak
4924	51.15	66.03	54	-2.85	31.12	6.89	52.89	119	47	Average
4924	53.49	68.37	74	-20.51	31.12	6.89	52.89	119	47	Peak
Antenna Polarity & Test Distance: Vertical at 3 m										
Frequency (MHz)	Emission Level (dBuV/m)	Read Level (dBuV)	Limit (dBuV/m)	Margin (dB)	Antenna Factor (dB/m)	Cable Loss (dB)	Preamp Factor (dB)	Antenna Height (cm)	Table Angle (Degree)	Remark
2462	100.49	106.37			27.1	4.41	37.39	100	74	Average
2462	104.39	110.27			27.1	4.41	37.39	100	74	Peak
2486.56	38.94	60.81	54	-15.06	27.15	4.94	53.96	100	74	Average
2486.56	52.33	58.07	74	-21.67	27.15	4.43	37.32	100	74	Peak
4924	45.94	60.82	54	-8.06	31.12	6.89	52.89	109	258	Average
4924	49.47	64.35	74	-24.53	31.12	6.89	52.89	109	258	Peak

Remarks:

- Emission Level = Read Level + Antenna Factor + Cable Loss - Preamp Factor
Margin value = Emission level – Limit value
- 2462 MHz: Fundamental frequency.

802.11g

EUT Test Condition		Measurement Detail	
Channel	Channel 1	Frequency Range	1 GHz ~ 25 GHz
Input Power	120 Vac, 60 Hz	Detector Function	Peak (PK) Average (AV)
Environmental Conditions	25 deg. C, 65 % RH	Tested By	Gavin Wu

Antenna Polarity & Test Distance: Horizontal at 3 m										
Frequency (MHz)	Emission Level (dBuV/m)	Read Level (dBuV)	Limit (dBuV/m)	Margin (dB)	Antenna Factor (dB/m)	Cable Loss (dB)	Preamp Factor (dB)	Antenna Height (cm)	Table Angle (Degree)	Remark
2389.92	47.12	69.25	54	-6.88	26.91	4.85	53.89	200	237	Average
2389.92	68.34	74.59	74	-5.66	26.91	4.36	37.52	200	237	Peak
2412	94.79	100.97			26.96	4.38	37.52	200	237	Average
2412	105.06	111.24			26.96	4.38	37.52	200	237	Peak
4824	34.74	49.83	54	-19.26	30.99	6.81	52.89	100	29	Average
4824	45.76	60.85	74	-28.24	30.99	6.81	52.89	100	29	Peak
Antenna Polarity & Test Distance: Vertical at 3 m										
Frequency (MHz)	Emission Level (dBuV/m)	Read Level (dBuV)	Limit (dBuV/m)	Margin (dB)	Antenna Factor (dB/m)	Cable Loss (dB)	Preamp Factor (dB)	Antenna Height (cm)	Table Angle (Degree)	Remark
2387.22	43.79	65.91	54	-10.21	26.91	4.84	53.87	100	94	Average
2387.22	65.31	71.54	74	-8.69	26.91	4.36	37.5	100	94	Peak
2412	92.1	98.28			26.96	4.38	37.52	100	94	Average
2412	102.59	108.77			26.96	4.38	37.52	100	94	Peak
4824	33.69	48.78	54	-20.31	30.99	6.81	52.89	100	278	Average
4824	44.55	59.64	74	-29.45	30.99	6.81	52.89	100	278	Peak

Remarks:

- Emission Level = Read Level + Antenna Factor + Cable Loss - Preamp Factor
Margin value = Emission level – Limit value
- 2412 MHz: Fundamental frequency.

EUT Test Condition		Measurement Detail	
Channel	Channel 6	Frequency Range	1 GHz ~ 25 GHz
Input Power	120 Vac, 60 Hz	Detector Function	Peak (PK) Average (AV)
Environmental Conditions	25 deg. C, 65 % RH	Tested By	Gavin Wu

Antenna Polarity & Test Distance: Horizontal at 3 m										
Frequency (MHz)	Emission Level (dBuV/m)	Read Level (dBuV)	Limit (dBuV/m)	Margin (dB)	Antenna Factor (dB/m)	Cable Loss (dB)	Preamp Factor (dB)	Antenna Height (cm)	Table Angle (Degree)	Remark
2388.75	39.33	61.44	54	-14.67	26.91	4.85	53.87	100	239	Average
2388.75	52.11	58.34	74	-21.89	26.91	4.36	37.5	100	239	Peak
2437	97.01	103.01			27.06	4.4	37.46	100	239	Average
2437	105.92	111.92			27.06	4.4	37.46	100	239	Peak
2487.28	37.55	59.42	54	-16.45	27.15	4.94	53.96	100	239	Average
2487.28	50.17	55.91	74	-23.83	27.15	4.43	37.32	100	239	Peak
4874	33.47	48.41	54	-20.53	31.06	6.86	52.86	100	52	Average
4874	43.45	58.39	74	-30.55	31.06	6.86	52.86	100	52	Peak
Antenna Polarity & Test Distance: Vertical at 3 m										
Frequency (MHz)	Emission Level (dBuV/m)	Read Level (dBuV)	Limit (dBuV/m)	Margin (dB)	Antenna Factor (dB/m)	Cable Loss (dB)	Preamp Factor (dB)	Antenna Height (cm)	Table Angle (Degree)	Remark
2389.02	37.84	59.95	54	-16.16	26.91	4.85	53.87	100	91	Average
2389.02	49.03	55.26	74	-24.97	26.91	4.36	37.5	100	91	Peak
2437	95.41	101.41			27.06	4.4	37.46	100	91	Average
2437	104.61	110.61			27.06	4.4	37.46	100	91	Peak
2486.48	37.47	59.34	54	-16.53	27.15	4.94	53.96	100	91	Average
2486.48	49.66	55.4	74	-24.34	27.15	4.43	37.32	100	91	Peak
4874	33.46	48.4	54	-20.54	31.06	6.86	52.86	100	276	Average
4874	44.7	59.64	74	-29.3	31.06	6.86	52.86	100	276	Peak

Remarks:

- Emission Level = Read Level + Antenna Factor + Cable Loss - Preamp Factor
Margin value = Emission level – Limit value
- 2437 MHz: Fundamental frequency.

EUT Test Condition		Measurement Detail	
Channel	Channel 11	Frequency Range	1 GHz ~ 25 GHz
Input Power	120 Vac, 60 Hz	Detector Function	Peak (PK) Average (AV)
Environmental Conditions	25 deg. C, 65 % RH	Tested By	Gavin Wu

Antenna Polarity & Test Distance: Horizontal at 3 m										
Frequency (MHz)	Emission Level (dBuV/m)	Read Level (dBuV)	Limit (dBuV/m)	Margin (dB)	Antenna Factor (dB/m)	Cable Loss (dB)	Preamp Factor (dB)	Antenna Height (cm)	Table Angle (Degree)	Remark
2462	96.9	102.78			27.1	4.41	37.39	200	233	Average
2462	105.99	111.87			27.1	4.41	37.39	200	233	Peak
2483.56	44.69	66.56	54	-9.31	27.15	4.94	53.96	200	233	Average
2483.56	64.2	69.94	74	-9.8	27.15	4.43	37.32	200	233	Peak
4924	33.77	48.65	54	-20.23	31.12	6.89	52.89	100	56	Average
4924	44.51	59.39	74	-29.49	31.12	6.89	52.89	100	56	Peak
Antenna Polarity & Test Distance: Vertical at 3 m										
Frequency (MHz)	Emission Level (dBuV/m)	Read Level (dBuV)	Limit (dBuV/m)	Margin (dB)	Antenna Factor (dB/m)	Cable Loss (dB)	Preamp Factor (dB)	Antenna Height (cm)	Table Angle (Degree)	Remark
2462	94.54	100.42			27.1	4.41	37.39	110	93	Average
2462	103.88	109.76			27.1	4.41	37.39	110	93	Peak
2484.12	44.13	66	54	-9.87	27.15	4.94	53.96	110	93	Average
2484.12	61.94	67.68	74	-12.06	27.15	4.43	37.32	110	93	Peak
4924	32.68	47.56	54	-21.32	31.12	6.89	52.89	100	56	Average
4924	43.92	58.8	74	-30.08	31.12	6.89	52.89	100	56	Peak

Remarks:

- Emission Level = Read Level + Antenna Factor + Cable Loss - Preamp Factor
Margin value = Emission level – Limit value
- 2462 MHz: Fundamental frequency.

802.11n (HT20)

EUT Test Condition		Measurement Detail	
Channel	Channel 1	Frequency Range	1 GHz ~ 25 GHz
Input Power	120 Vac, 60 Hz	Detector Function	Peak (PK) Average (AV)
Environmental Conditions	25 deg. C, 65 % RH	Tested By	Gavin Wu

Antenna Polarity & Test Distance: Horizontal at 3 m

Frequency (MHz)	Emission Level (dBuV/m)	Read Level (dBuV)	Limit (dBuV/m)	Margin (dB)	Antenna Factor (dB/m)	Cable Loss (dB)	Preamp Factor (dB)	Antenna Height (cm)	Table Angle (Degree)	Remark
2389.74	52.63	74.74	54	-1.37	26.91	4.85	53.87	223	237	Average
2389.74	72.73	78.96	74	-1.27	26.91	4.36	37.5	223	237	Peak
2412	96.66	102.84			26.96	4.38	37.52	223	237	Average
2412	105.95	112.13			26.96	4.38	37.52	223	237	Peak
4824	37.81	52.9	54	-16.19	30.99	6.81	52.89	100	48	Average
4824	48.24	63.33	74	-25.76	30.99	6.81	52.89	100	48	Peak

Antenna Polarity & Test Distance: Vertical at 3 m

Frequency (MHz)	Emission Level (dBuV/m)	Read Level (dBuV)	Limit (dBuV/m)	Margin (dB)	Antenna Factor (dB/m)	Cable Loss (dB)	Preamp Factor (dB)	Antenna Height (cm)	Table Angle (Degree)	Remark
2389.11	51.13	73.24	54	-2.87	26.91	4.85	53.87	109	289	Average
2389.11	70.85	77.08	74	-3.15	26.91	4.36	37.5	109	289	Peak
2412	94.36	100.54			26.96	4.38	37.52	109	289	Average
2412	104.11	110.29			26.96	4.38	37.52	109	289	Peak
4824	34.29	49.38	54	-19.71	30.99	6.81	52.89	100	111	Average
4824	43.08	58.17	74	-30.92	30.99	6.81	52.89	100	111	Peak

Remarks:

- Emission Level = Read Level + Antenna Factor + Cable Loss - Preamp Factor
Margin value = Emission level – Limit value
- 2412 MHz: Fundamental frequency.

EUT Test Condition		Measurement Detail	
Channel	Channel 6	Frequency Range	1 GHz ~ 25 GHz
Input Power	120 Vac, 60 Hz	Detector Function	Peak (PK) Average (AV)
Environmental Conditions	25 deg. C, 65 % RH	Tested By	Gavin Wu

Antenna Polarity & Test Distance: Horizontal at 3 m										
Frequency (MHz)	Emission Level (dBuV/m)	Read Level (dBuV)	Limit (dBuV/m)	Margin (dB)	Antenna Factor (dB/m)	Cable Loss (dB)	Preamp Factor (dB)	Antenna Height (cm)	Table Angle (Degree)	Remark
2389.47	51.76	57.99	74	-22.24	26.91	4.36	37.5	219	236	Peak
2389.74	39.39	61.5	54	-14.61	26.91	4.85	53.87	219	236	Average
2437	98.19	104.19			27.06	4.4	37.46	219	236	Average
2437	107.98	113.98			27.06	4.4	37.46	219	236	Peak
2486.32	39.69	61.56	54	-14.31	27.15	4.94	53.96	219	236	Average
2486.32	52.39	58.13	74	-21.61	27.15	4.43	37.32	219	236	Peak
4874	37.53	52.47	54	-16.47	31.06	6.86	52.86	100	249	Average
4874	49.98	64.92	74	-24.02	31.06	6.86	52.86	100	249	Peak
Antenna Polarity & Test Distance: Vertical at 3 m										
Frequency (MHz)	Emission Level (dBuV/m)	Read Level (dBuV)	Limit (dBuV/m)	Margin (dB)	Antenna Factor (dB/m)	Cable Loss (dB)	Preamp Factor (dB)	Antenna Height (cm)	Table Angle (Degree)	Remark
2384.16	39.28	61.45	54	-14.72	26.86	4.84	53.87	110	293	Average
2384.16	51.37	57.66	74	-22.63	26.86	4.35	37.5	110	293	Peak
2437	96.63	102.63			27.06	4.4	37.46	110	293	Average
2437	105.77	111.77			27.06	4.4	37.46	110	293	Peak
2483.52	38.9	60.77	54	-15.1	27.15	4.94	53.96	110	293	Average
2483.52	51.43	57.17	74	-22.57	27.15	4.43	37.32	110	293	Peak
4874	35.87	50.81	54	-18.13	31.06	6.86	52.86	100	255	Average
4874	46.28	61.22	74	-27.72	31.06	6.86	52.86	100	255	Peak

Remarks:

- Emission Level = Read Level + Antenna Factor + Cable Loss - Preamp Factor
Margin value = Emission level – Limit value
- 2437 MHz: Fundamental frequency.

EUT Test Condition		Measurement Detail	
Channel	Channel 11	Frequency Range	1 GHz ~ 25 GHz
Input Power	120 Vac, 60 Hz	Detector Function	Peak (PK) Average (AV)
Environmental Conditions	25 deg. C, 65 % RH	Tested By	Gavin Wu

Antenna Polarity & Test Distance: Horizontal at 3 m										
Frequency (MHz)	Emission Level (dBuV/m)	Read Level (dBuV)	Limit (dBuV/m)	Margin (dB)	Antenna Factor (dB/m)	Cable Loss (dB)	Preamp Factor (dB)	Antenna Height (cm)	Table Angle (Degree)	Remark
2462	97.66	103.54			27.1	4.41	37.39	200	238	Average
2462	107.04	112.92			27.1	4.41	37.39	200	238	Peak
2483.52	52.98	58.72	54	-1.02	27.15	4.43	37.32	200	238	Average
2483.52	72.93	78.67	74	-1.07	27.15	4.43	37.32	200	238	Peak
4924	38.18	53.06	54	-15.82	31.12	6.89	52.89	100	44	Average
4924	50.06	64.94	74	-23.94	31.12	6.89	52.89	100	44	Peak
Antenna Polarity & Test Distance: Vertical at 3 m										
Frequency (MHz)	Emission Level (dBuV/m)	Read Level (dBuV)	Limit (dBuV/m)	Margin (dB)	Antenna Factor (dB/m)	Cable Loss (dB)	Preamp Factor (dB)	Antenna Height (cm)	Table Angle (Degree)	Remark
2462	95.96	101.84			27.1	4.41	37.39	100	72	Average
2462	105.89	111.77			27.1	4.41	37.39	100	72	Peak
2483.52	51.14	56.88	54	-2.86	27.15	4.43	37.32	100	72	Average
2483.52	71.73	77.47	74	-2.27	27.15	4.43	37.32	100	72	Peak
4924	35.43	50.31	54	-18.57	31.12	6.89	52.89	100	257	Average
4924	46.68	61.56	74	-27.32	31.12	6.89	52.89	100	257	Peak

Remarks:

- Emission Level = Read Level + Antenna Factor + Cable Loss - Preamp Factor
Margin value = Emission level – Limit value
- 2462 MHz: Fundamental frequency.

802.11n (HT40)

EUT Test Condition		Measurement Detail	
Channel	Channel 3	Frequency Range	1 GHz ~ 25 GHz
Input Power	120 Vac, 60 Hz	Detector Function	Peak (PK) Average (AV)
Environmental Conditions	25 deg. C, 65 % RH	Tested By	Gavin Wu

Antenna Polarity & Test Distance: Horizontal at 3 m

Frequency (MHz)	Emission Level (dBuV/m)	Read Level (dBuV)	Limit (dBuV/m)	Margin (dB)	Antenna Factor (dB/m)	Cable Loss (dB)	Preamp Factor (dB)	Antenna Height (cm)	Table Angle (Degree)	Remark
2386.59	53	75.12	54	-1	26.91	4.84	53.87	200	251	Average
2386.59	71.18	77.41	74	-2.82	26.91	4.36	37.5	200	251	Peak
2422	94.17	100.23			27.01	4.39	37.46	200	251	Average
2422	103.45	109.51			27.01	4.39	37.46	200	251	Peak
2499.08	38.06	59.89	54	-15.94	27.2	4.95	53.98	200	251	Average
2499.08	50.28	55.89	74	-23.72	27.2	4.44	37.25	200	251	Peak
4844	36.71	51.75	54	-17.29	31.01	6.83	52.88	100	48	Average
4844	46.45	61.49	74	-27.55	31.01	6.83	52.88	100	48	Peak

Antenna Polarity & Test Distance: Vertical at 3 m

Frequency (MHz)	Emission Level (dBuV/m)	Read Level (dBuV)	Limit (dBuV/m)	Margin (dB)	Antenna Factor (dB/m)	Cable Loss (dB)	Preamp Factor (dB)	Antenna Height (cm)	Table Angle (Degree)	Remark
2389.65	50.81	72.92	54	-3.19	26.91	4.85	53.87	109	270	Average
2389.65	68.24	74.47	74	-5.76	26.91	4.36	37.5	109	270	Peak
2422	92.58	98.64			27.01	4.39	37.46	109	270	Average
2422	101.72	107.78			27.01	4.39	37.46	109	270	Peak
2484.84	36.85	58.72	54	-17.15	27.15	4.94	53.96	109	270	Average
2484.84	49.04	54.78	74	-24.96	27.15	4.43	37.32	109	270	Peak
4844	35.37	50.41	54	-18.63	31.01	6.83	52.88	100	255	Average
4844	45.83	60.87	74	-28.17	31.01	6.83	52.88	100	255	Peak

Remarks:

- Emission Level = Read Level + Antenna Factor + Cable Loss - Preamp Factor
Margin value = Emission level – Limit value
- 2422 MHz: Fundamental frequency.

EUT Test Condition		Measurement Detail	
Channel	Channel 6	Frequency Range	1 GHz ~ 25 GHz
Input Power	120 Vac, 60 Hz	Detector Function	Peak (PK) Average (AV)
Environmental Conditions	25 deg. C, 65 % RH	Tested By	Gavin Wu

Antenna Polarity & Test Distance: Horizontal at 3 m										
Frequency (MHz)	Emission Level (dBuV/m)	Read Level (dBuV)	Limit (dBuV/m)	Margin (dB)	Antenna Factor (dB/m)	Cable Loss (dB)	Preamp Factor (dB)	Antenna Height (cm)	Table Angle (Degree)	Remark
2389.38	53	75.11	54	-1	26.91	4.85	53.87	200	248	Average
2389.38	70.89	77.12	74	-3.11	26.91	4.36	37.5	200	248	Peak
2437	95.4	101.4			27.06	4.4	37.46	200	248	Average
2437	104.56	110.56			27.06	4.4	37.46	200	248	Peak
2484.04	46.66	68.53	54	-7.34	27.15	4.94	53.96	200	248	Average
2484.04	65.65	71.39	74	-8.35	27.15	4.43	37.32	200	248	Peak
4874	37.95	52.89	54	-16.05	31.06	6.86	52.86	100	225	Average
4874	46.64	61.58	74	-27.36	31.06	6.86	52.86	100	225	Peak
Antenna Polarity & Test Distance: Vertical at 3 m										
Frequency (MHz)	Emission Level (dBuV/m)	Read Level (dBuV)	Limit (dBuV/m)	Margin (dB)	Antenna Factor (dB/m)	Cable Loss (dB)	Preamp Factor (dB)	Antenna Height (cm)	Table Angle (Degree)	Remark
2389.83	52.1	74.23	54	-1.9	26.91	4.85	53.89	110	269	Average
2389.83	68.9	75.15	74	-5.1	26.91	4.36	37.52	110	269	Peak
2437	93.22	99.22			27.06	4.4	37.46	110	269	Average
2437	102.3	108.3			27.06	4.4	37.46	110	269	Peak
2485.28	48	69.87	54	-6	27.15	4.94	53.96	110	269	Average
2485.28	68.32	74.06	74	-5.68	27.15	4.43	37.32	110	269	Peak
4874	36.04	50.98	54	-17.96	31.06	6.86	52.86	100	83	Average
4874	45.93	60.87	74	-28.07	31.06	6.86	52.86	100	83	Peak

Remarks:

- Emission Level = Read Level + Antenna Factor + Cable Loss - Preamp Factor
Margin value = Emission level – Limit value
- 2437 MHz: Fundamental frequency.

EUT Test Condition		Measurement Detail	
Channel	Channel 9	Frequency Range	1 GHz ~ 25 GHz
Input Power	120 Vac, 60 Hz	Detector Function	Peak (PK) Average (AV)
Environmental Conditions	25 deg. C, 65 % RH	Tested By	Gavin Wu

Antenna Polarity & Test Distance: Horizontal at 3 m										
Frequency (MHz)	Emission Level (dBuV/m)	Read Level (dBuV)	Limit (dBuV/m)	Margin (dB)	Antenna Factor (dB/m)	Cable Loss (dB)	Preamp Factor (dB)	Antenna Height (cm)	Table Angle (Degree)	Remark
2389.47	40.57	46.8	54	-13.43	26.91	4.36	37.5	200	246	Average
2389.47	55.99	62.22	74	-18.01	26.91	4.36	37.5	200	246	Peak
2452	94.44	100.36			27.06	4.41	37.39	200	246	Average
2452	103.51	109.43			27.06	4.41	37.39	200	246	Peak
2484.44	53.47	75.34	54	-0.53	27.15	4.94	53.96	200	246	Average
2484.44	72.11	77.85	74	-1.89	27.15	4.43	37.32	200	246	Peak
4904	36.61	51.48	54	-17.39	31.1	6.88	52.85	100	126	Average
4904	46.38	61.25	74	-27.62	31.1	6.88	52.85	100	126	Peak
Antenna Polarity & Test Distance: Vertical at 3 m										
Frequency (MHz)	Emission Level (dBuV/m)	Read Level (dBuV)	Limit (dBuV/m)	Margin (dB)	Antenna Factor (dB/m)	Cable Loss (dB)	Preamp Factor (dB)	Antenna Height (cm)	Table Angle (Degree)	Remark
2387.94	39.89	62	54	-14.11	26.91	4.85	53.87	110	268	Average
2387.94	54.2	60.43	74	-19.8	26.91	4.36	37.5	110	268	Peak
2452	92.42	98.34			27.06	4.41	37.39	110	268	Average
2452	101.04	106.96			27.06	4.41	37.39	110	268	Peak
2486.08	53.01	74.88	54	-0.99	27.15	4.94	53.96	110	268	Average
2486.08	71.14	76.88	74	-2.86	27.15	4.43	37.32	110	268	Peak
4904	35.52	50.39	54	-18.48	31.1	6.88	52.85	100	51	Average
4904	45.16	60.03	74	-28.84	31.1	6.88	52.85	100	51	Peak

Remarks:

- Emission Level = Read Level + Antenna Factor + Cable Loss - Preamp Factor
Margin value = Emission level – Limit value
- 2452 MHz: Fundamental frequency.

9 kHz ~ 30 MHz Data:

The amplitude of spurious emissions attenuated more than 20 dB below the permissible value is not required to be report.

30 MHz ~ 1 GHz Worst-Case Data:

802.11n (HT40)

EUT Test Condition		Measurement Detail	
Channel	Channel 9	Frequency Range	30 MHz ~ 1 GHz
Input Power	120 Vac, 60 Hz	Detector Function	Peak (PK) Quasi-peak (QP)
Environmental Conditions	25 deg. C, 65 % RH	Tested By	Gavin Wu

Antenna Polarity & Test Distance: Horizontal at 3 m										
Frequency (MHz)	Emission Level (dBuV/m)	Read Level (dBuV)	Limit (dBuV/m)	Margin (dB)	Antenna Factor (dB/m)	Cable Loss (dB)	Preamp Factor (dB)	Antenna Height (cm)	Table Angle (Degree)	Remark
43.58	21.46	38.48	40	-18.54	13.59	0.5	31.11	113	290	Peak
127.97	27.78	47.23	43.5	-15.72	11.55	0.88	31.88	114	297	Peak
181.32	29.53	49.55	43.5	-13.97	10.67	1.13	31.82	100	200	Peak
240.49	35.09	54.37	46	-10.91	11.07	1.44	31.79	117	233	Peak
472.32	23.51	36.24	46	-22.49	16.77	2.38	31.88	119	266	Peak
798.24	28.55	34.1	46	-17.45	22.2	3.67	31.42	131	32	Peak
Antenna Polarity & Test Distance: Vertical at 3 m										
Frequency (MHz)	Emission Level (dBuV/m)	Read Level (dBuV)	Limit (dBuV/m)	Margin (dB)	Antenna Factor (dB/m)	Cable Loss (dB)	Preamp Factor (dB)	Antenna Height (cm)	Table Angle (Degree)	Remark
46.49	29.66	46.94	40	-10.34	13.39	0.52	31.19	127	206	Peak
69.77	35.15	55.56	40	-4.85	10.77	0.64	31.82	139	166	Peak
180.35	26.94	46.92	43.5	-16.56	10.74	1.12	31.84	122	163	Peak
353.98	21.78	37.53	46	-24.22	14.24	1.9	31.89	132	178	Peak
500.45	25.78	37.55	46	-20.22	17.33	2.52	31.62	131	192	Peak
823.46	27.33	32.68	46	-18.67	22.53	3.76	31.64	118	299	Peak

Remarks:

- Emission Level = Read Level + Antenna Factor + Cable Loss - Preamp Factor
Margin value = Emission level – Limit value

4.2 Conducted Emission Measurement

4.2.1 Limits of Conducted Emission Measurement

Frequency (MHz)	Conducted Limit (dBuV)	
	Quasi-peak	Average
0.15 - 0.5	66 - 56	56 - 46
0.50 - 5.0	56	46
5.0 - 30.0	60	50

- Note: 1. The lower limit shall apply at the transition frequencies.
 2. The limit decreases in line with the logarithm of the frequency in the range of 0.15 to 0.50 MHz.

4.2.2 Test Instruments

Description & Manufacturer	Model No.	Serial No.	Date of Calibration	Due Date of Calibration
Test Receiver ROHDE & SCHWARZ	ESCI	100613	Nov. 21, 2016	Nov. 20, 2017
RF signal cable (with 10dB PAD) Woken	5D-FB	Cable-cond1-01	Sep. 05, 2017	Sep. 04, 2018
LISN/AMN ROHDE & SCHWARZ (EUT)	ESH3-Z5	835239/001	Mar. 10, 2017	Mar. 09, 2018
LISN/AMN ROHDE & SCHWARZ (Peripheral)	ENV216	101196	Apr. 20, 2017	Apr. 19, 2018
Software ADT	BV ADT_Cond_ V7.3.7.3	NA	NA	NA

- Note: 1. The calibration interval of the above test instruments is 12 months and the calibrations are traceable to NML/ROC and NIST/USA.
 2. The test was performed in HwaYa Shielded Room 1.
 3. The VCCI Site Registration No. is C-2040.

4.2.3 Test Procedures

- a. The EUT was placed 0.4 meters from the conducting wall of the shielded room with EUT being connected to the power mains through a line impedance stabilization network (LISN). Other support units were connected to the power mains through another LISN. The two LISNs provide 50 ohm/50 uH of coupling impedance for the measuring instrument.
- b. Both lines of the power mains connected to the EUT were checked for maximum conducted interference.
- c. The frequency range from 150 kHz to 30 MHz was searched. Emission levels under (Limit – 20 dB) was not recorded.

NOTE: All modes of operation were investigated and the worst-case emissions are reported.

4.2.4 Deviation from Test Standard

No deviation.

4.2.5 Test Setup

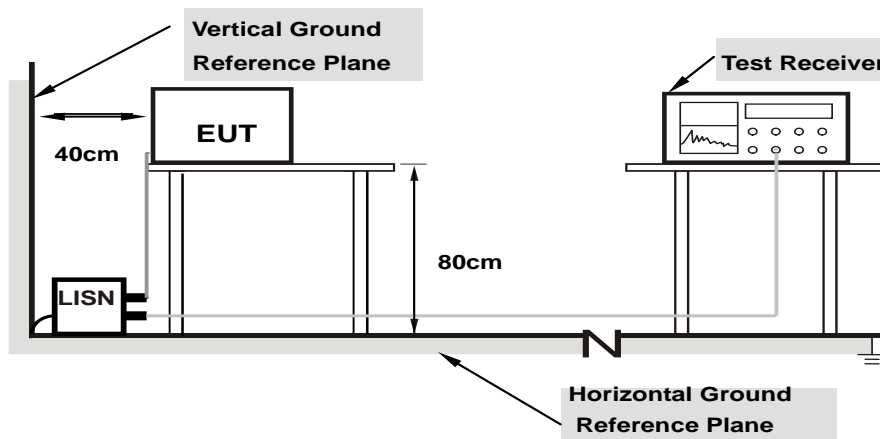

Note: 1.Support units were connected to second LISN.

For the actual test configuration, please refer to the attached file (Test Setup Photo).

4.2.6 EUT Operating Conditions

- a. Placed the EUT on a testing table.
- b. Use the software to control the EUT under transmission condition continuously at specific channel frequency.

4.2.7 Test Results

Frequency Range	150kHz ~ 30MHz	Detector Function & Resolution Bandwidth	Quasi-Peak (QP) / Average (AV), 9kHz
Input Power	120Vac, 60Hz	Environmental Conditions	25°C, 65%RH
Tested by	Getaz Yang	Test Date	2017/9/19

Phase Of Power : Line (L)										
No	Frequency (MHz)	Correction Factor (dB)	Reading Value (dBuV)		Emission Level (dBuV)		Limit (dBuV)		Margin (dB)	
			Q.P.	AV.	Q.P.	AV.	Q.P.	AV.	Q.P.	AV.
1	0.15800	10.39	34.97	20.22	45.36	30.61	65.57	55.57	-20.21	-24.96
2	0.18228	10.39	30.23	16.27	40.62	26.66	64.38	54.38	-23.76	-27.72
3	0.22624	10.40	22.99	10.05	33.39	20.45	62.59	52.59	-29.20	-32.14
4	0.34214	10.40	11.84	3.14	22.24	13.54	59.15	49.15	-36.91	-35.61
5	0.49476	10.41	10.82	6.63	21.23	17.04	56.09	46.09	-34.86	-29.05
6	4.94200	10.60	9.43	3.26	20.03	13.86	56.00	46.00	-35.97	-32.14

Remarks:

1. Q.P. and AV. are abbreviations of quasi-peak and average individually.
2. The emission levels of other frequencies were very low against the limit.
3. Margin value = Emission level – Limit value
4. Correction factor = Insertion loss + Cable loss
5. Emission Level = Correction Factor + Reading Value

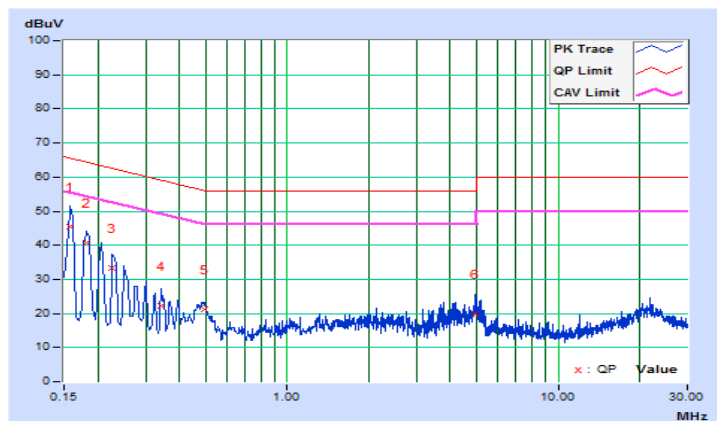

Frequency Range	150kHz ~ 30MHz	Detector Function & Resolution Bandwidth	Quasi-Peak (QP) / Average (AV), 9kHz
Input Power	120Vac, 60Hz	Environmental Conditions	25°C, 65%RH
Tested by	Getaz Yang	Test Date	2017/9/19

Phase Of Power : Neutral (N)										
No	Frequency (MHz)	Correction Factor (dB)	Reading Value (dBuV)		Emission Level (dBuV)		Limit (dBuV)		Margin (dB)	
			Q.P.	AV.	Q.P.	AV.	Q.P.	AV.	Q.P.	AV.
1	0.15400	10.15	35.82	20.97	45.97	31.12	65.78	55.78	-19.81	-24.66
2	0.17801	10.16	31.71	17.48	41.87	27.64	64.58	54.58	-22.71	-26.94
3	0.22200	10.16	26.33	12.49	36.49	22.65	62.74	52.74	-26.25	-30.09
4	0.48200	10.17	14.05	8.89	24.22	19.06	56.30	46.30	-32.08	-27.24
5	5.03800	10.37	7.16	0.64	17.53	11.01	60.00	50.00	-42.47	-38.99
6	21.57801	11.01	6.95	1.26	17.96	12.27	60.00	50.00	-42.04	-37.73

Remarks:

1. Q.P. and AV. are abbreviations of quasi-peak and average individually.
2. The emission levels of other frequencies were very low against the limit.
3. Margin value = Emission level – Limit value
4. Correction factor = Insertion loss + Cable loss
5. Emission Level = Correction Factor + Reading Value

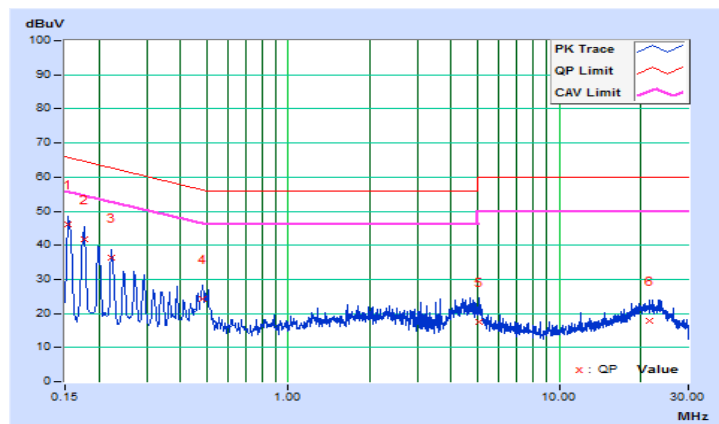

4.3 6 dB Bandwidth Measurement

4.3.1 Limits of 6 dB Bandwidth Measurement

The minimum of 6 dB Bandwidth Measurement is 0.5 MHz.

4.3.2 Test Setup

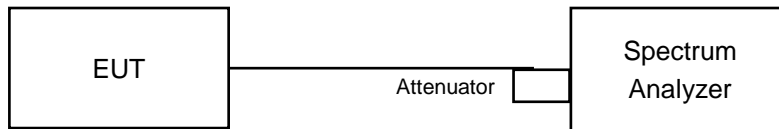

4.3.3 Test Instruments

Refer to section 4.1.2 to get information of above instrument.

4.3.4 Test Procedure

- a. Set resolution bandwidth (RBW) = 100 kHz
- b. Set the video bandwidth (VBW) $\geq 3 \times$ RBW, Detector = Peak.
- c. Trace mode = max hold.
- d. Sweep = auto couple.
- e. Measure the maximum width of the emission that is constrained by the frequencies associated with the two amplitude points (upper and lower) that are attenuated by 6 dB relative to the maximum level measured in the fundamental emission

4.3.5 Deviation from Test Standard

No deviation.

4.3.6 EUT Operating Conditions

The software provided by client to enable the EUT under transmission condition continuously at lowest, middle and highest channel frequencies individually.

4.3.7 Test Result

802.11b

Channel	Frequency (MHz)	6 dB Bandwidth (MHz)	Minimum Limit (MHz)	Pass / Fail
1	2412	9.59	0.5	Pass
6	2437	9.56	0.5	Pass
11	2462	10.04	0.5	Pass

802.11g

Channel	Frequency (MHz)	6 dB Bandwidth (MHz)	Minimum Limit (MHz)	Pass / Fail
1	2412	16.35	0.5	Pass
6	2437	16.36	0.5	Pass
11	2462	16.36	0.5	Pass

802.11n (HT20)

Channel	Frequency (MHz)	6 dB Bandwidth (MHz)	Minimum Limit (MHz)	Pass / Fail
1	2412	17.57	0.5	Pass
6	2437	17.60	0.5	Pass
11	2462	17.59	0.5	Pass

802.11n (HT40)

Channel	Frequency (MHz)	6 dB Bandwidth (MHz)	Minimum Limit (MHz)	Pass / Fail
3	2422	35.08	0.5	Pass
6	2437	35.78	0.5	Pass
9	2452	35.89	0.5	Pass

Spectrum Plot of Worst Value

802.11b

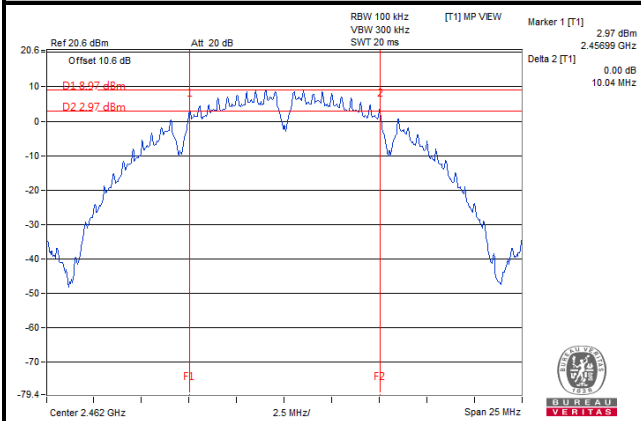

802.11g

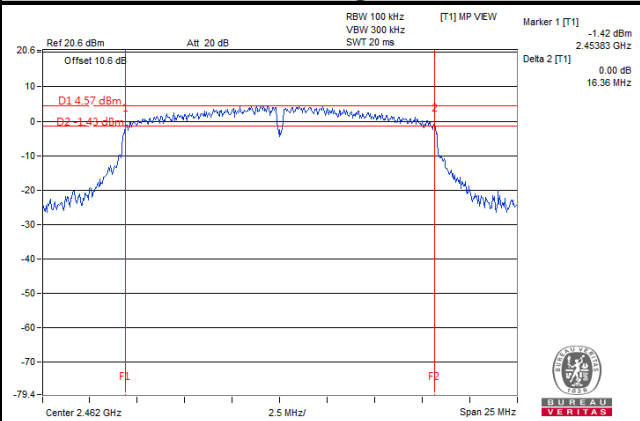

802.11n (HT20)

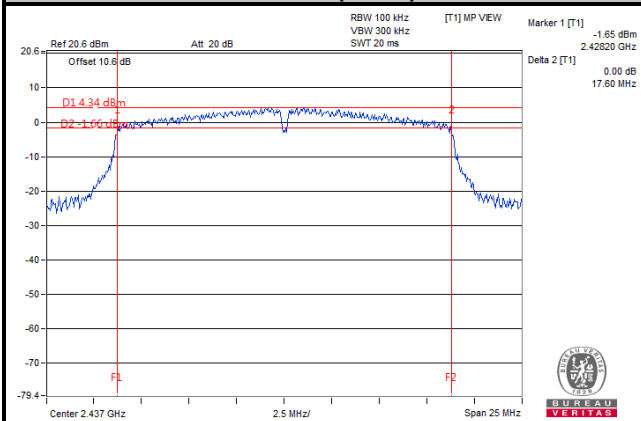

802.11n (HT40)

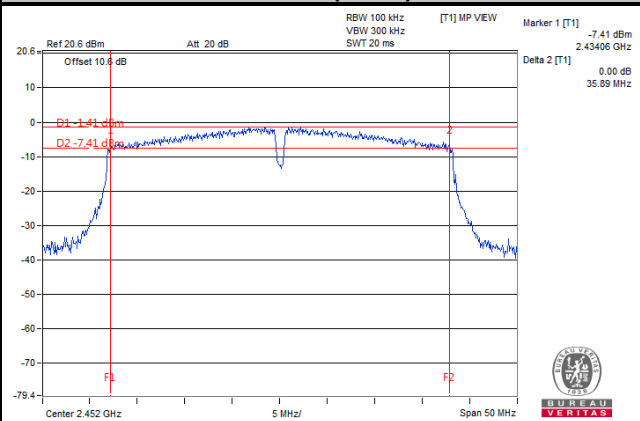

4.4 Occupied Bandwidth Measurement

4.4.1 Test Setup

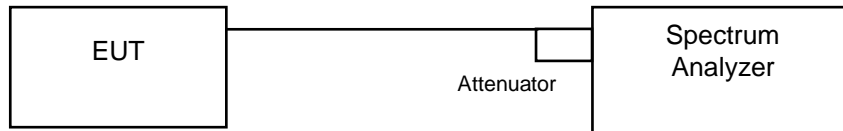

4.4.2 Test Instruments

Refer to section 4.1.2 to get information of above instrument.

4.4.3 Test Procedure

The transmitter output was connected to the spectrum analyzer through an attenuator. The bandwidth of the fundamental frequency was measured by spectrum analyzer with resolution bandwidth in the range of 1 % to 5 % of the anticipated emission bandwidth, and a video bandwidth at least 3x the resolution bandwidth and set the detector to PEAK. The width of a frequency band such that, below the lower and above the upper frequency limits, the mean powers emitted are each equal to a specified percentage 0.5 % of the total mean power of a given emission.

4.4.4 Deviation from Test Standard

No deviation.

4.4.5 EUT Operating Conditions

The software provided by client to enable the EUT under transmission condition continuously at lowest, middle and highest channel frequencies individually.

4.4.6 Test Results

802.11b

Channel	Frequency (MHz)	Occupied Bandwidth (MHz)	Pass / Fail
1	2412	14.42	Pass
6	2437	14.20	Pass
11	2462	14.40	Pass

802.11g

Channel	Frequency (MHz)	Occupied Bandwidth (MHz)	Pass / Fail
1	2412	16.73	Pass
6	2437	16.70	Pass
11	2462	16.70	Pass

802.11n (HT20)

Channel	Frequency (MHz)	Occupied Bandwidth (MHz)	Pass / Fail
1	2412	17.69	Pass
6	2437	17.70	Pass
11	2462	17.70	Pass

802.11n (HT40)

Channel	Frequency (MHz)	Occupied Bandwidth (MHz)	Pass / Fail
3	2422	36.05	Pass
6	2437	36.16	Pass
9	2452	36.33	Pass

Spectrum Plot of Worst Value

802.11b

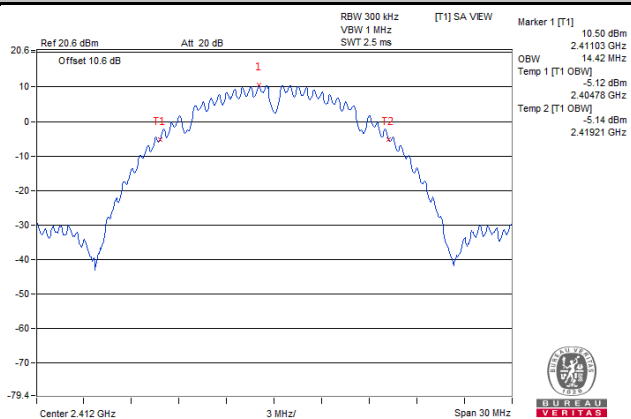

802.11g

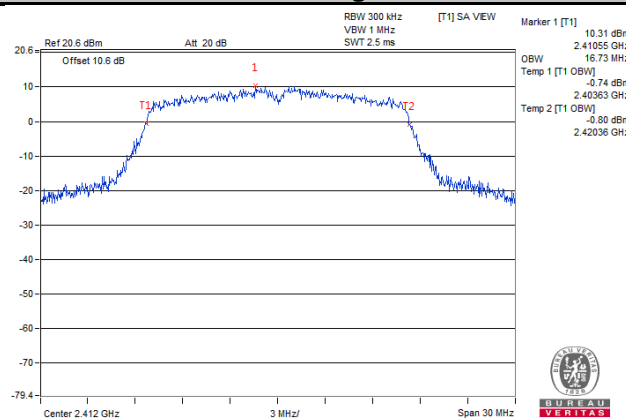

802.11n (HT20)

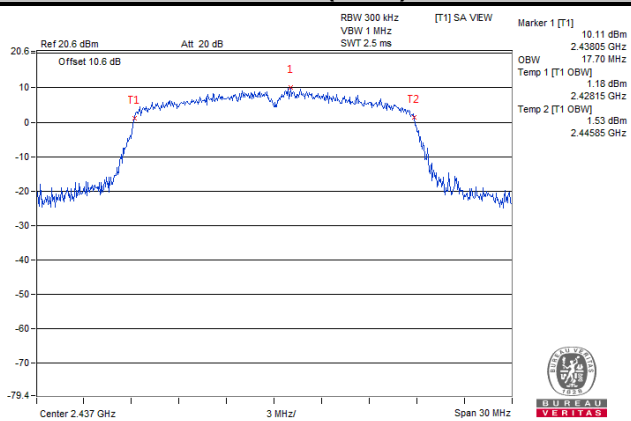

802.11n (HT40)

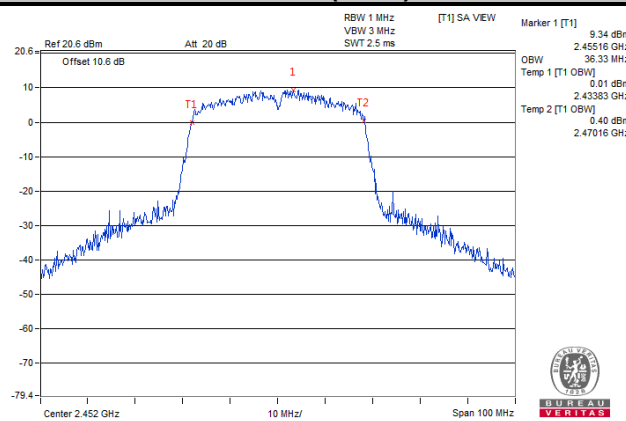

4.5 Conducted Output Power Measurement

4.5.1 Limits of Conducted Output Power Measurement

For systems using digital modulation in the 2400–2483.5 MHz bands: 1 Watt (30 dBm)

4.5.2 Test Setup

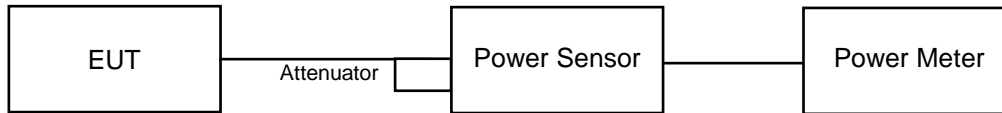

4.5.3 Test Instruments

Refer to section 4.1.2 to get information of above instrument.

4.5.4 Test Procedures

A peak power sensor was used on the output port of the EUT. A power meter was used to read the response of the peak power sensor. Record the power level.

4.5.5 Deviation from Test Standard

No deviation.

4.5.6 EUT Operating Conditions

The software provided by client to enable the EUT under transmission condition continuously at lowest, middle and highest channel frequencies individually.

4.5.7 Test Results

802.11b

Channel	Frequency (MHz)	Peak Power (mW)	Peak Power (dBm)	Limit (dBm)	Pass / Fail
1	2412	136.773	21.36	30	Pass
6	2437	159.588	22.03	30	Pass
11	2462	154.525	21.89	30	Pass

802.11g

Channel	Frequency (MHz)	Peak Power (mW)	Peak Power (dBm)	Limit (dBm)	Pass / Fail
1	2412	274.789	24.39	30	Pass
6	2437	281.19	24.49	30	Pass
11	2462	276.694	24.42	30	Pass

802.11n (HT20)

Channel	Frequency (MHz)	Peak Power (mW)	Peak Power (dBm)	Limit (dBm)	Pass / Fail
1	2412	179.061	22.53	30	Pass
6	2437	255.859	24.08	30	Pass
11	2462	247.172	23.93	30	Pass

802.11n (HT40)

Channel	Frequency (MHz)	Peak Power (mW)	Peak Power (dBm)	Limit (dBm)	Pass / Fail
3	2422	177.419	22.49	30	Pass
6	2437	206.063	23.14	30	Pass
9	2452	169.434	22.29	30	Pass

4.6 Power Spectral Density Measurement

4.6.1 Limits of Power Spectral Density Measurement

The Maximum of Power Spectral Density Measurement is 8 dBm.

4.6.2 Test Setup

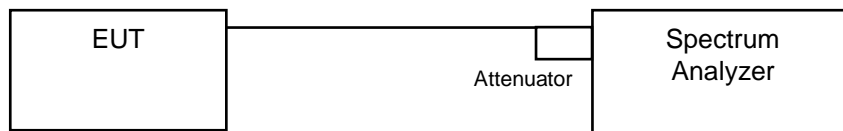

4.6.3 Test Instruments

Refer to section 4.1.2 to get information of above instrument.

4.6.4 Test Procedure

- a. Set analyzer center frequency to DTS channel center frequency.
- b. Set the span to 1.5 times the DTS bandwidth.
- c. Set the RBW to: $3 \text{ kHz} \leq \text{RBW} \leq 100 \text{ kHz}$.
- d. Set the VBW $\geq 3 \times \text{RBW}$.
- e. Detector = peak.
- f. Sweep time = auto couple.
- g. Trace mode = max hold.
- h. Allow trace to fully stabilize.
- i. Use the peak marker function to determine the maximum amplitude level within the RBW.

4.6.5 Deviation from Test Standard

No deviation.

4.6.6 EUT Operating Condition

The software provided by client to enable the EUT under transmission condition continuously at lowest, middle and highest channel frequencies individually.

4.6.7 Test Results

802.11b

Channel	Frequency (MHz)	PSD (dBm/3 kHz)	Limit (dBm/3 kHz)	Pass / Fail
1	2412	-6.05	8	Pass
6	2437	-6.55	8	Pass
11	2462	-6.66	8	Pass

802.11g

Channel	Frequency (MHz)	PSD (dBm/3 kHz)	Limit (dBm/3 kHz)	Pass / Fail
1	2412	-7.48	8	Pass
6	2437	-7.62	8	Pass
11	2462	-7.23	8	Pass

802.11n (HT20)

Channel	Frequency (MHz)	PSD (dBm/3 kHz)	Limit (dBm/3 kHz)	Pass / Fail
1	2412	-9.46	8	Pass
6	2437	-8.61	8	Pass
11	2462	-8.61	8	Pass

802.11n (HT40)

Channel	Frequency (MHz)	PSD (dBm/3 kHz)	Limit (dBm/3 kHz)	Pass / Fail
3	2422	-13.58	8	Pass
6	2437	-12.93	8	Pass
9	2452	-12.83	8	Pass

Spectrum Plot of Worst Value

802.11b

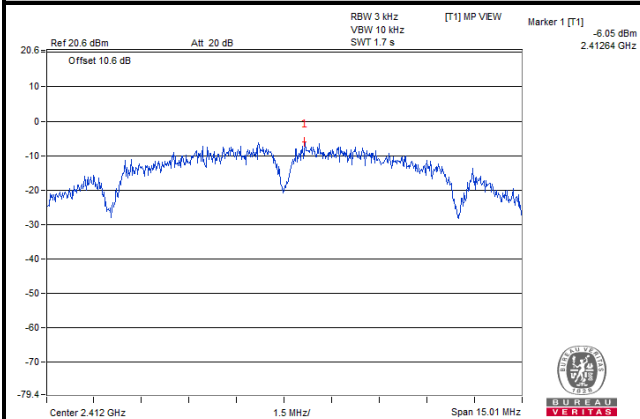

802.11g

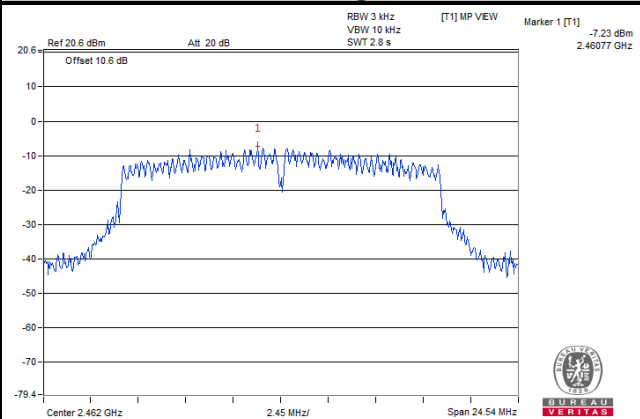

802.11n (HT20)

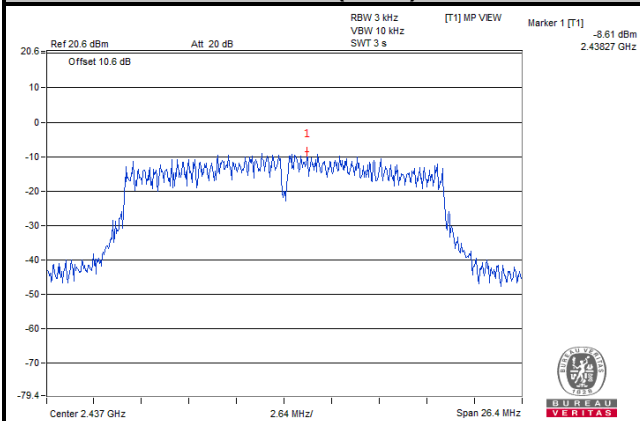

802.11n (HT40)

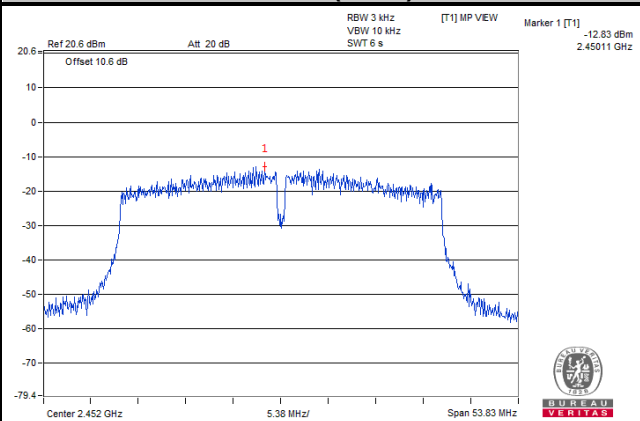

4.7 Conducted Out of Band Emission Measurement

4.7.1 Limits of Conducted Out of Band Emission Measurement

Below 20 dB of the highest emission level of operating band (in 100 kHz Resolution Bandwidth).

4.7.2 Test Setup

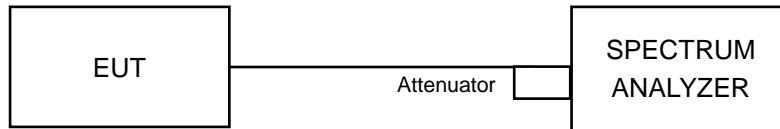

4.7.3 Test Instruments

Refer to section 4.1.2 to get information of above instrument.

4.7.4 Test Procedure

MEASUREMENT PROCEDURE REF

1. Set the RBW = 100 kHz.
2. Set the VBW \geq 300 kHz.
3. Detector = peak.
4. Sweep time = auto couple.
5. Trace mode = max hold.
6. Allow trace to fully stabilize.
7. Use the peak marker function to determine the maximum power level in any 100 kHz band segment within the fundamental EBW.

MEASUREMENT PROCEDURE OOB

1. Set RBW = 100 kHz.
2. Set VBW \geq 300 kHz.
3. Detector = peak.
4. Sweep = auto couple.
5. Trace Mode = max hold.
6. Allow trace to fully stabilize.
7. Use the peak marker function to determine the maximum amplitude level.

4.7.5 Deviation from Test Standard

No deviation.

4.7.6 EUT Operating Condition

The software provided by client to enable the EUT under transmission condition continuously at lowest, middle and highest channel frequencies individually.

4.7.7 Test Results

The spectrum plots are attached on the following images. D1 line indicates the highest level, and D2 line indicates the 20 dB offset below D1. It shows compliance with the requirement.

802.11b

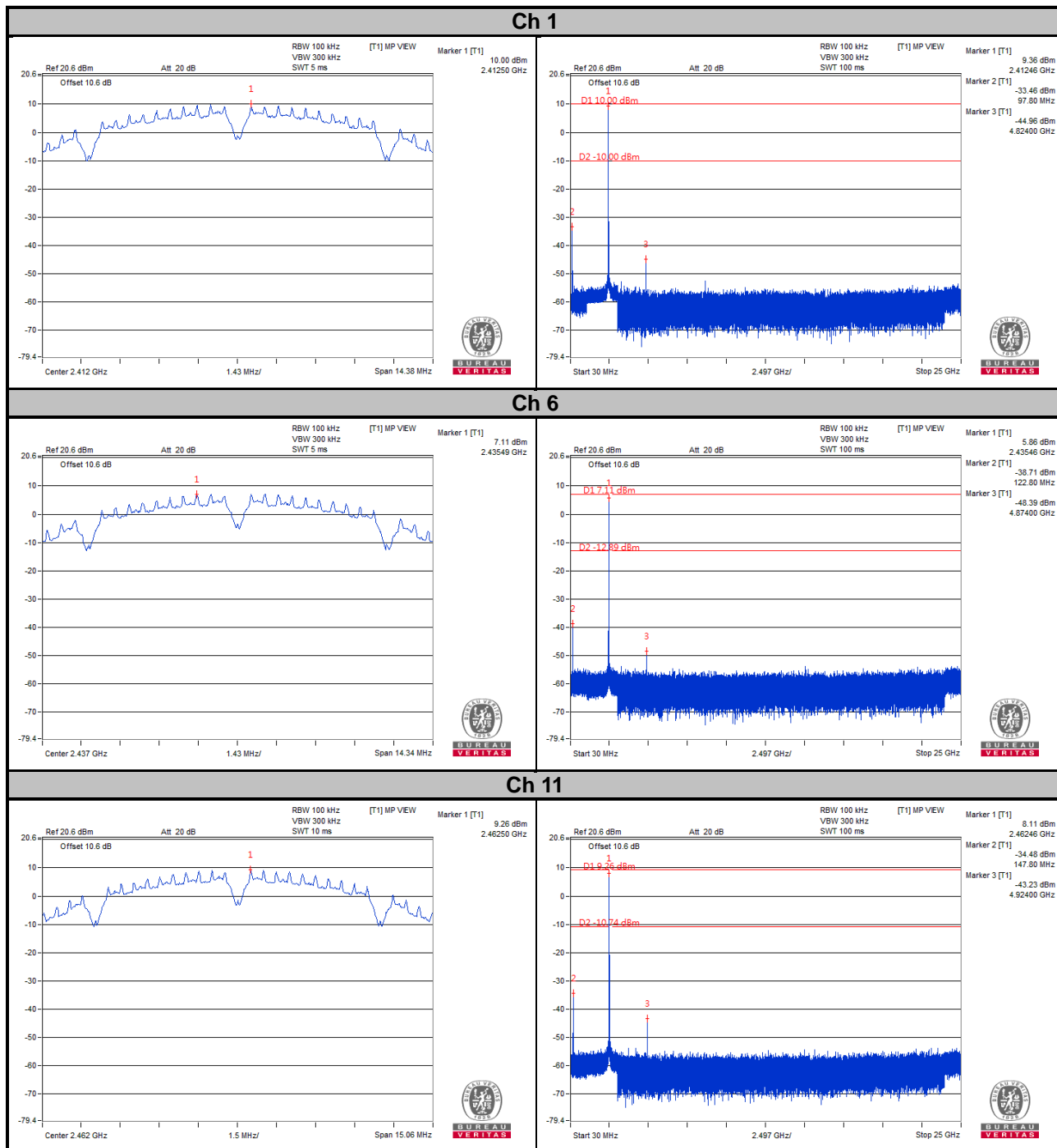

Ch 1 Band Edge

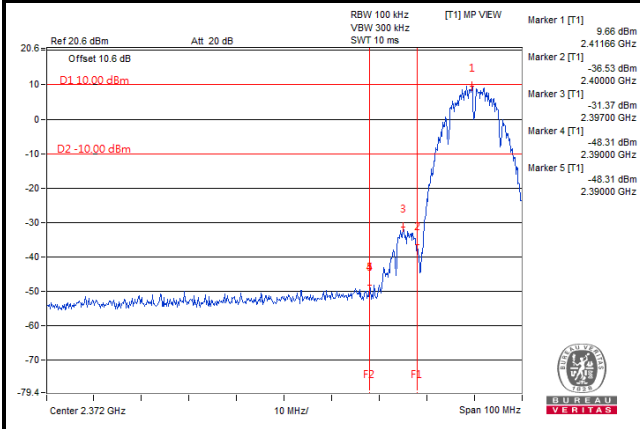

Ch 11 Band Edge

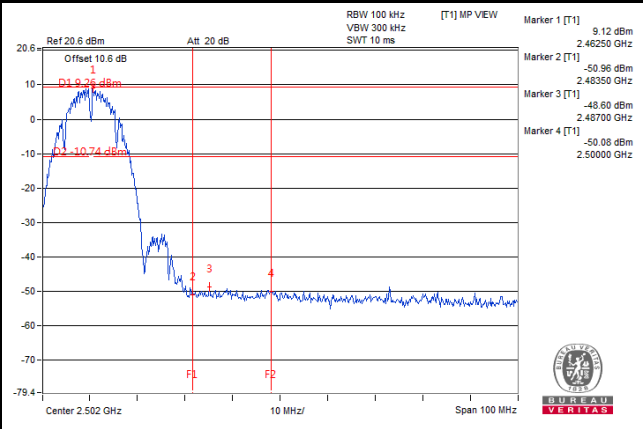

802.11g

Ch 1

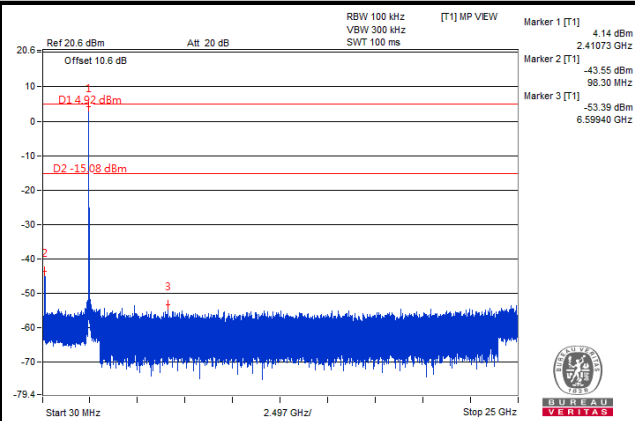
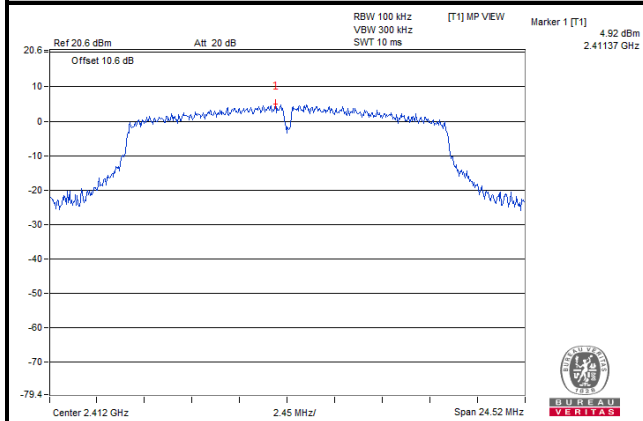

Ch 6

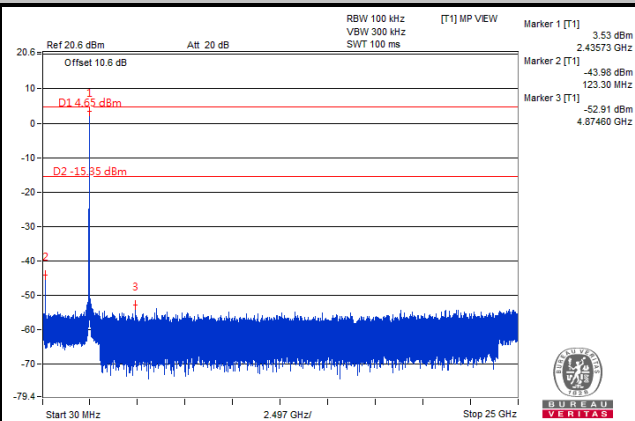
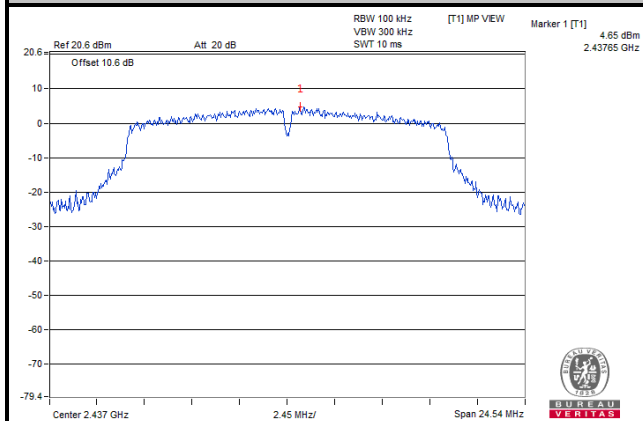

Ch 11

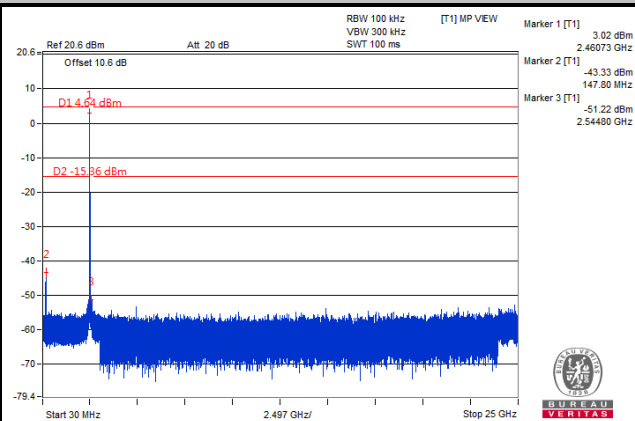
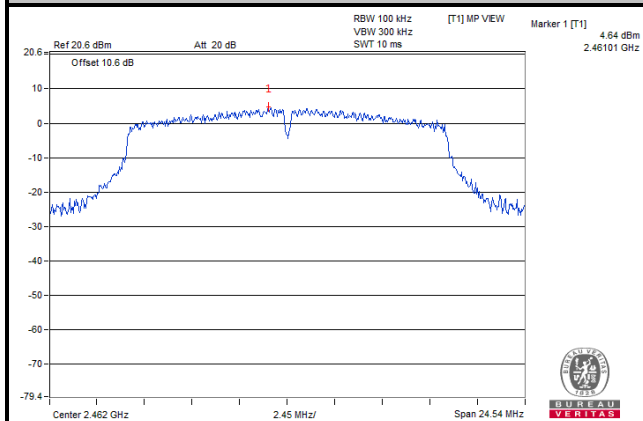

Ch 1 Band Edge

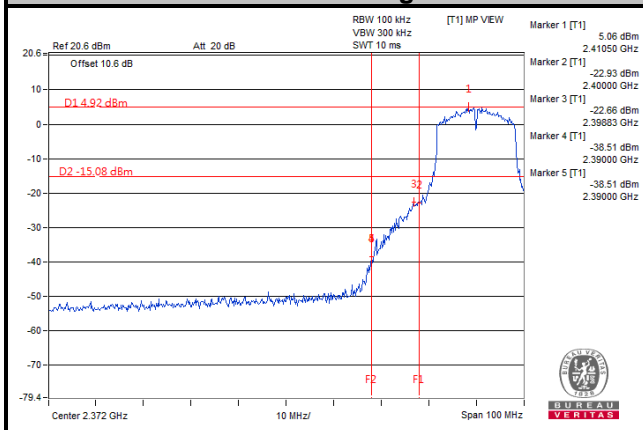

Ch 11 Band Edge

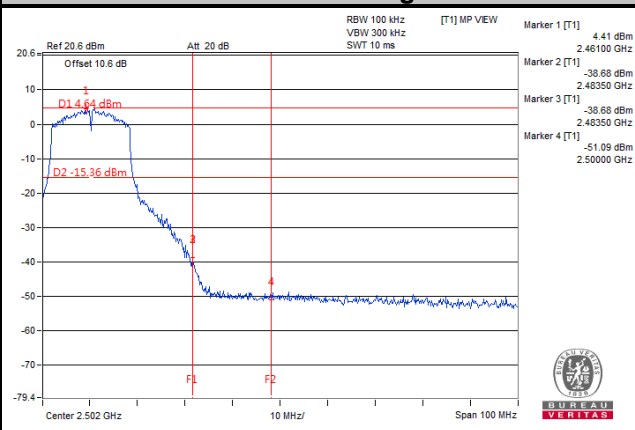

802.11n (HT20)

Ch 1

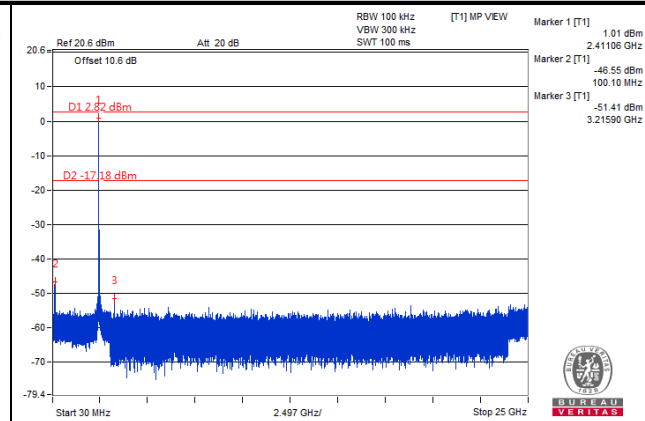
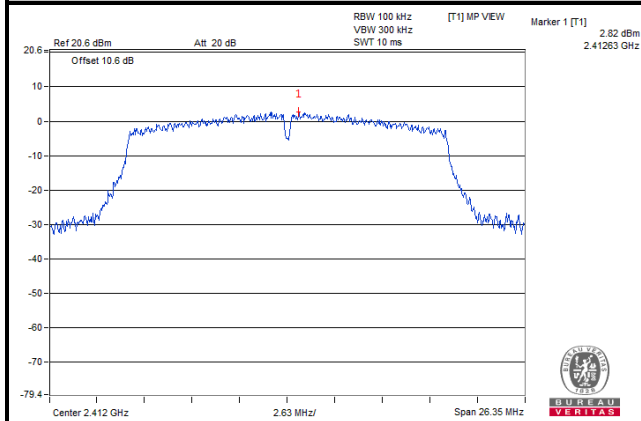

Ch 6

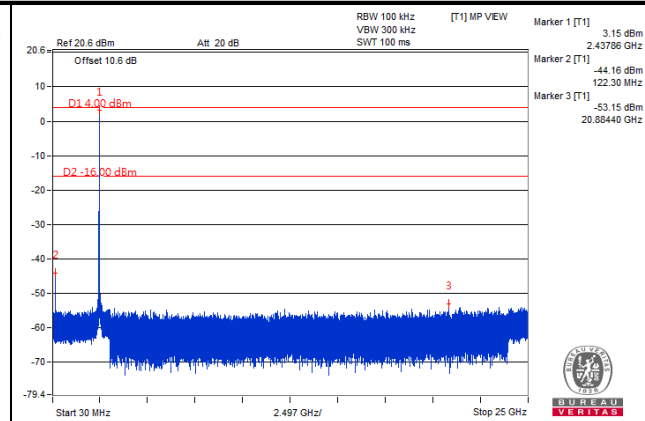
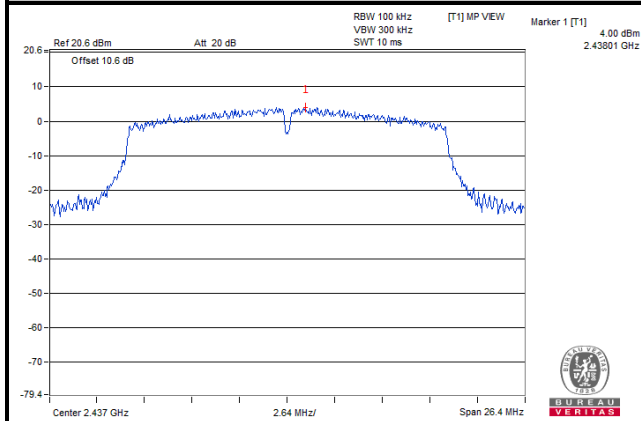

Ch 11

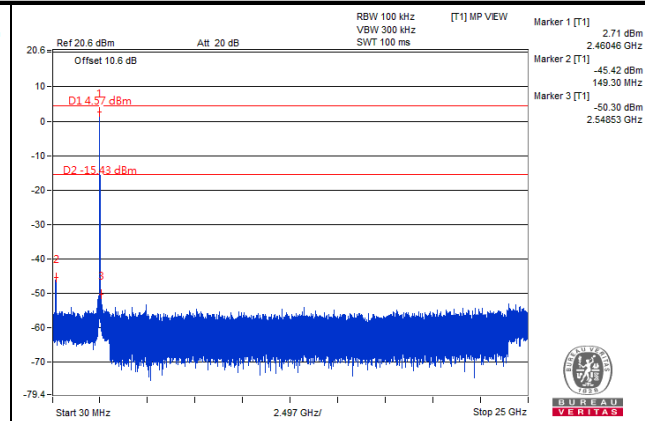
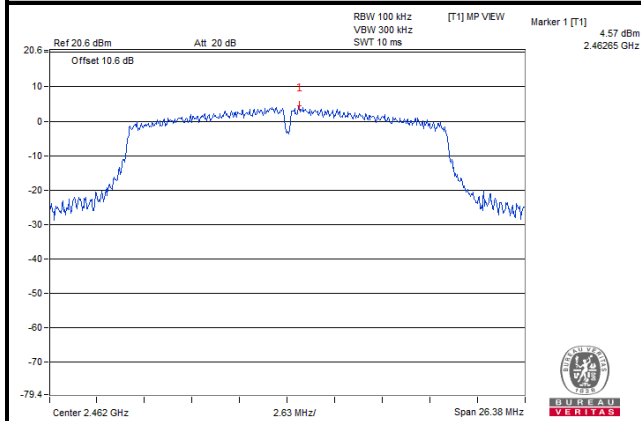

Ch 1 Band Edge

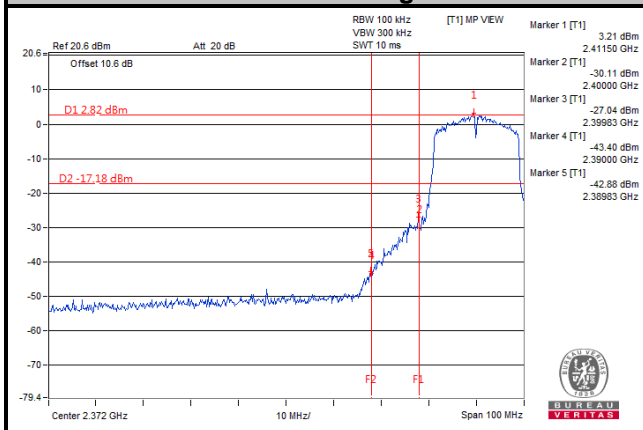

Ch 11 Band Edge

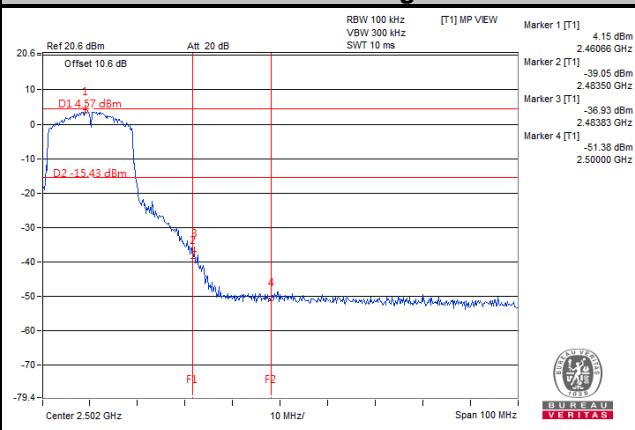

802.11n (HT40)

Ch 3

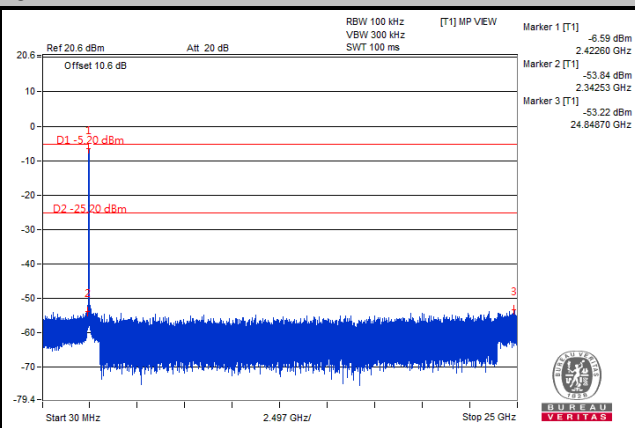
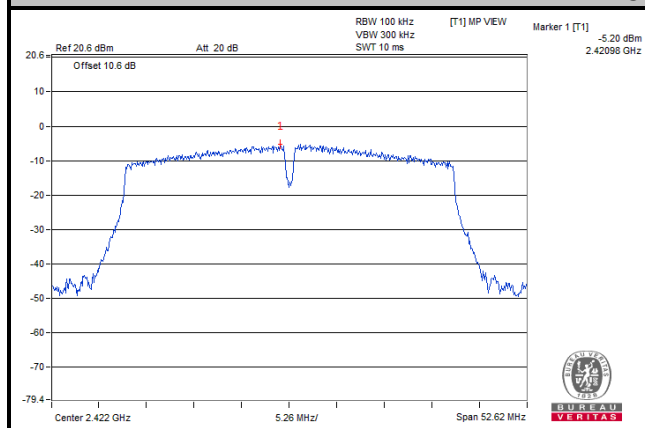

Ch 6

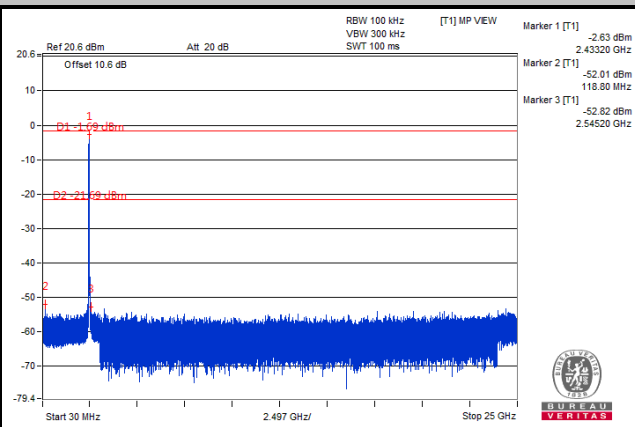
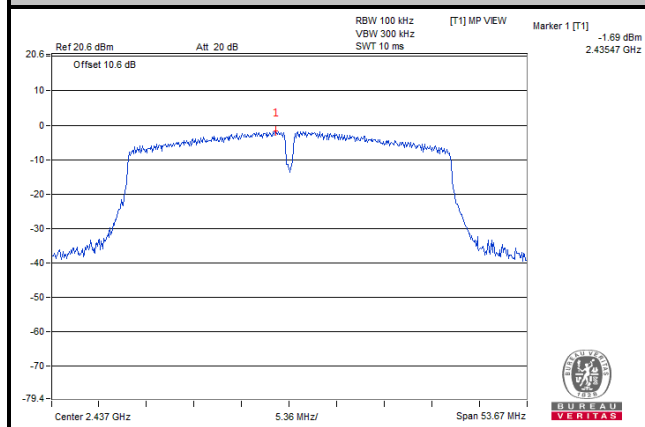

Ch 9

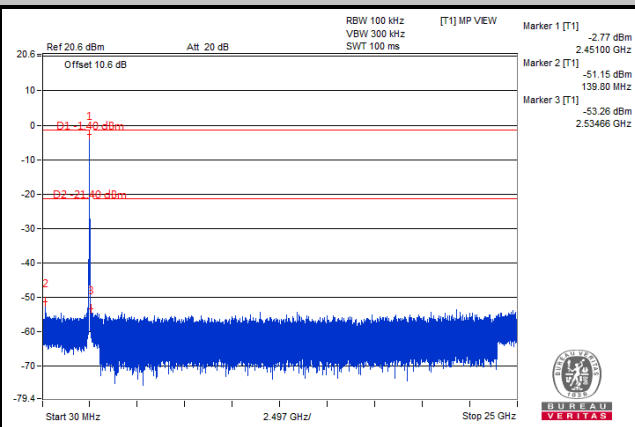
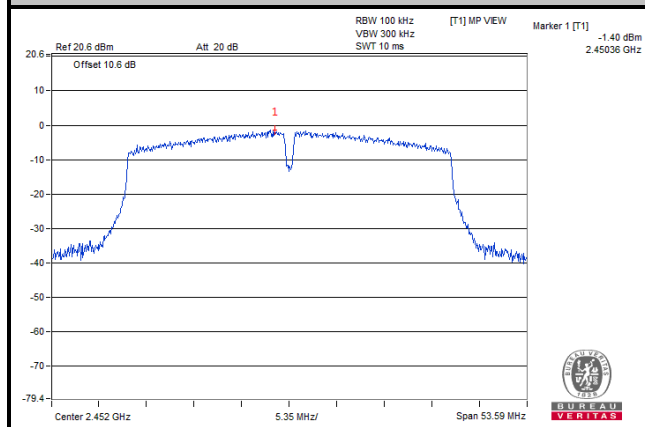

Ch 3 Band Edge

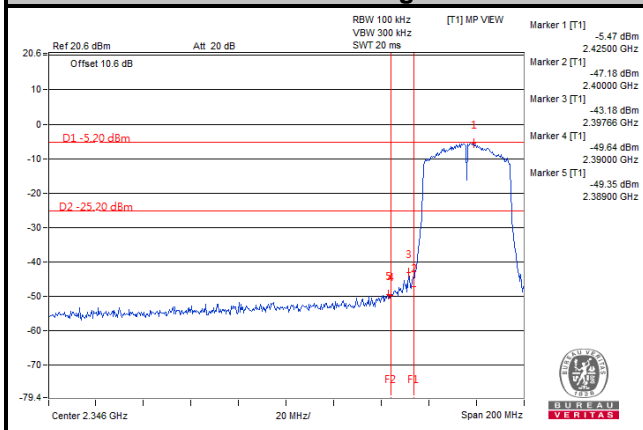

Ch 9 Band Edge

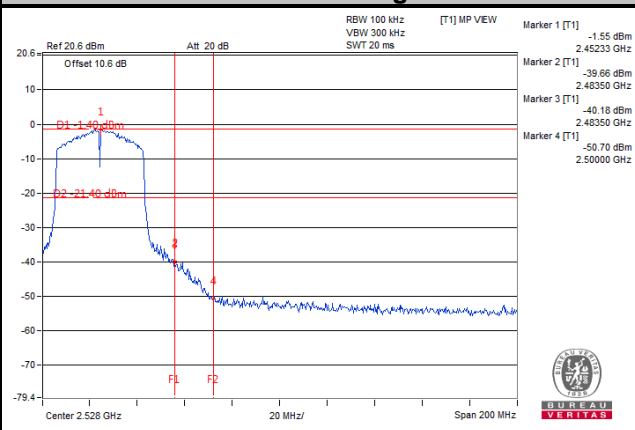

5 Pictures of Test Arrangements

Please refer to the attached file (Test Setup Photo).

Appendix – Information on the Testing Laboratories

We, Bureau Veritas Consumer Products Services (H.K.) Ltd., Taoyuan Branch, were founded in 1988 to provide our best service in EMC, Radio, Telecom and Safety consultation. Our laboratories are FCC recognized accredited test firms and accredited according to ISO/IEC 17025.

If you have any comments, please feel free to contact us at the following:

Linko EMC/RF Lab

Tel: 886-2-26052180

Fax: 886-2-26051924

Hsin Chu EMC/RF/Telecom Lab

Tel: 886-3-6668565

Fax: 886-3-6668323

Hwa Ya EMC/RF/Safety Lab

Tel: 886-3-3183232

Fax: 886-3-3270892

Email: service.adt@tw.bureauveritas.com

Web Site: www.bureauveritas-adt.com

The address and road map of all our labs can be found in our web site also.

--- END ---