

FCC Test Report

FCC ID : 2ADWC-AI50H
Equipment : LoRa module
Model No. : AI50H
Brand Name : Acsip
Applicant : AcSiP Technology Corp.
Address : 9F, No. 242, Bo'ai St., Shulin Dist., New Taipei
City 238005, Taiwan (R.O.C.)
Standard : 47 CFR FCC Part 15.247
Received Date : Aug. 16, 2021
Tested Date : Aug. 20 ~ Aug. 30, 2021

We, International Certification Corp., would like to declare that the tested sample has been evaluated and in compliance with the requirement of the above standards. The test results contained in this report refer exclusively to the product. It may be duplicated completely for legal use with the approval of the applicant. It shall not be reproduced except in full without the written approval of our laboratory.

Reviewed by:



Along Chen / Assistant Manager

Approved by:



Gary Chang / Manager



Table of Contents

1	GENERAL DESCRIPTION	5
1.1	Information.....	5
1.2	Local Support Equipment List	8
1.3	Test Setup Chart	8
1.4	The Equipment List	9
1.5	Test Standards	10
1.6	Reference Guidance	10
1.7	Deviation from Test Standard and Measurement Procedure.....	10
1.8	Measurement Uncertainty	10
2	TEST CONFIGURATION	11
2.1	Testing Facility.....	11
2.2	The Worst Test Modes and Channel Details	11
3	TRANSMITTER TEST RESULTS.....	12
3.1	Conducted Emissions.....	12
3.2	Unwanted Emissions into Restricted Frequency Bands	25
3.3	Unwanted Emissions into Non-Restricted Frequency Bands	51
3.4	Conducted Output Power	56
3.5	Number of Hopping Frequency	57
3.6	20dB and Occupied Bandwidth	60
3.7	Channel Separation.....	63
3.8	Number of Dwell Time.....	66
3.9	Power Spectral Density	74
4	TEST LABORATORY INFORMATION	77

Release Record

Report No.	Version	Description	Issued Date
FR181602	Rev. 01	Initial issue	Sep. 17, 2021

Summary of Test Results

FCC Rules	Test Items	Measured	Result
15.207	Conducted Emissions	[dBuV]: 0.538MHz 29.93 (Margin -16.07dB) - AV	Pass
15.247(d) 15.209	Radiated Emissions	[dBuV/m at 3m]: 7268.00MHz 52.74 (Margin -1.26dB) - AV	Pass
15.247(d)	Band Edge	Meet the requirement of limit	Pass
15.247(b)(2)(3)	Conducted Output Power	Power [dBm]: 21.09	Pass
15.247(a)(1)(i)	Number of Hopping Channels	Meet the requirement of limit	Pass
15.247(a)(1)	Hopping Channel Separation	Meet the requirement of limit	Pass
15.247(f)	Dwell Time	Meet the requirement of limit	Pass
15.247(f)	Power spectral density	Meet the requirement of limit	Pass
15.203	Antenna Requirement	Meet the requirement of limit	Pass

Declaration of Conformity:

The test results with all measurement uncertainty excluded are presented in accordance with the regulation limits or requirements declared by manufacturers.

Comments and Explanations:

The declared of product specification for EUT presented in the report are provided by the manufacturer, and the manufacturer takes all the responsibilities for the accuracy of product specification.

1 General Description

1.1 Information

1.1.1 Specification of the Equipment under Test (EUT)

RF General Information					
Frequency Range (MHz)	Ch. Freq. (MHz)	Channel List	Data Rate (bit/sec)	Spread Factor	Channel Bandwidth (kHz)
902 ~ 928	902.3 ~ 914.9	64 channels	980-5.47k bps	7 ~ 10	125
902 ~ 928	903 ~ 914.2	8 channels	12.5k bps	8	500

Note 1: RF output power specifies that Maximum Conducted (Average) Output Power.
 Note 2: The device uses LoRa modulation.
 Note 3: The device supports hybrid mode.

1.1.2 Antenna Details

Ant. No.	Model	Type	Connector	Gain (dBi)
1	RFA-WAVE-C55-U-B70-1	Dipole	R-SMA	2
2	OMA-G01	Dipole	N type	8

1.1.3 Power Supply Type of Equipment under Test (EUT)

Power Supply Type	3.3Vdc from host
--------------------------	------------------

1.1.4 Accessories

N/A

1.1.5 Channel List

Channel Bandwidth: 125KHz							
Channel	Frequency (MHz)	Channel	Frequency (MHz)	Channel	Frequency (MHz)	Channel	Frequency (MHz)
0	902.3	16	905.5	32	908.7	48	911.9
1	902.5	17	905.7	33	908.9	49	912.1
2	902.7	18	905.9	34	909.1	50	912.3
3	902.9	19	906.1	35	909.3	51	912.5
4	903.1	20	906.3	36	909.5	52	912.7
5	903.3	21	906.5	37	909.7	53	912.9
6	903.5	22	906.7	38	909.9	54	913.1
7	903.7	23	906.9	39	910.1	55	913.3
8	903.9	24	907.1	40	910.3	56	913.5
9	904.1	25	907.3	41	910.5	57	913.7
10	904.3	26	907.5	42	910.7	58	913.9
11	904.5	27	907.7	43	910.9	59	914.1
12	904.7	28	907.9	44	911.1	60	914.3
13	904.9	29	908.1	45	911.3	61	914.5
14	905.1	30	908.3	46	911.5	62	914.7
15	905.3	31	908.5	47	911.7	63	914.9

Channel Bandwidth: 500KHz			
Channel	Frequency(MHz)	Channel	Frequency(MHz)
64	903	68	909.4
65	904.6	69	911
66	906.2	70	912.6
67	907.8	71	914.2

1.1.6 Test Tool and Duty Cycle

Test Tool	Termite, ver. 3.3	
Duty Cycle and Duty Factor	Duty Cycle (%)	Duty Factor (dB)
Channel Bandwidth: 125KHz	98.75%	0.05
Channel Bandwidth: 500KHz	79.84%	0.98

1.1.7 Power Setting

Channel Bandwidth: 125KHz	
Test Frequency (MHz)	Power Index
902.3	21
908.5	21
914.9	21

Channel Bandwidth: 500KHz	
Test Frequency (MHz)	Power Index
903	22
907.8	22
914.2	22

1.2 Local Support Equipment List

Support Equipment List					
No.	Equipment	Brand	Model	FCC ID	Remarks
1	Notebook	DELL	Latitude E5470	DoC	---
2	Fixture	---	---	---	Provided by applicant.

1.3 Test Setup Chart

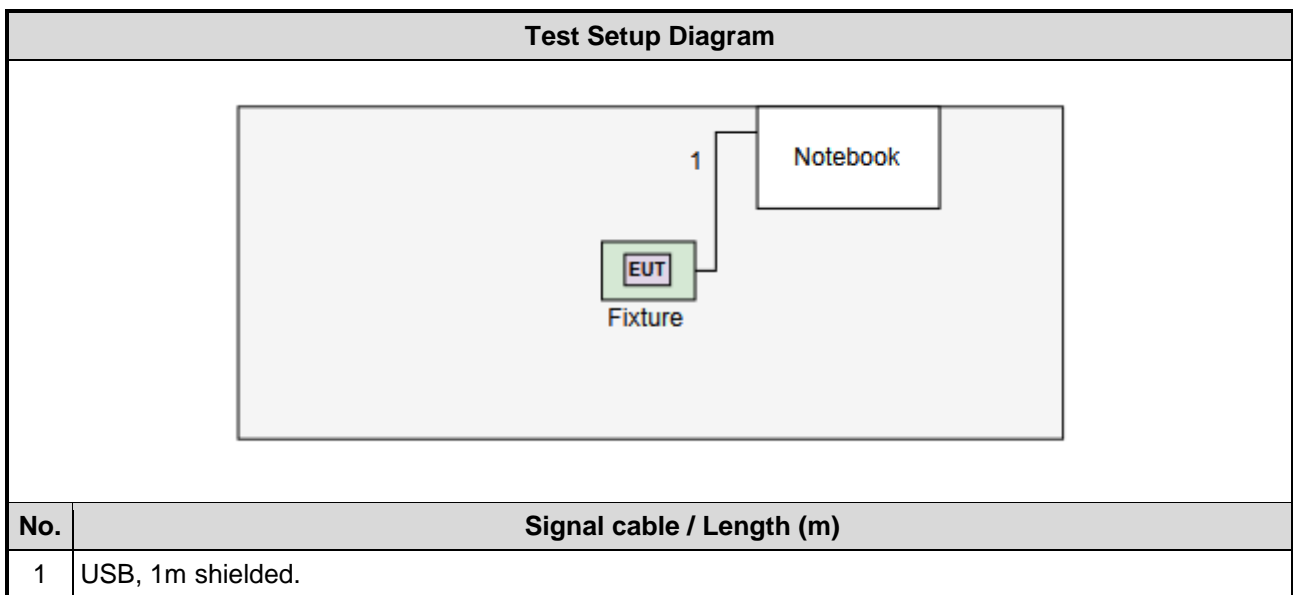

1.4 The Equipment List

Test Item	Conducted Emission				
Test Site	Conduction room 1 / (CO01-WS)				
Tested Date	Aug. 30, 2021				
Instrument	Brand	Model No.	Serial No.	Calibration Date	Calibration Until
Receiver	R&S	ESR3	101658	Feb. 08, 2021	Feb. 07, 2022
LISN	R&S	ENV216	101579	Mar. 17, 2021	Mar. 16, 2022
LISN (Support Unit)	SCHWARZBECK	Schwarzbeck 8127	8127-666	Dec. 29, 2020	Dec. 28, 2021
RF Cable-CON	Woken	CFD200-NL	CFD200-NL-001	Oct. 21, 2020	Oct. 20, 2021
50 ohm terminal (Support Unit)	NA	50	04	May 25, 2021	May 24, 2022
Measurement Software	AUDIX	e3	6.120210k	NA	NA
Note: Calibration Interval of instruments listed above is one year.					

Test Item	Radiated Emission				
Test Site	966 chamber1 / (03CH01-WS)				
Tested Date	Aug. 20, 2021				
Instrument	Brand	Model No.	Serial No.	Calibration Date	Calibration Until
Receiver	R&S	ESR3	101657	Mar. 12, 2021	Mar. 11, 2022
Spectrum Analyzer	R&S	FSV40	101498	Dec. 04, 2020	Dec. 03, 2021
Loop Antenna	R&S	HFH2-Z2	100330	Nov. 17, 2020	Nov. 16, 2021
Bilog Antenna	SCHWARZBECK	VULB9168	VULB9168-522	Jun. 30, 2021	Jun. 29, 2022
Horn Antenna 1G-18G	SCHWARZBECK	BBHA 9120 D	BBHA 9120 D 1096	Dec. 11, 2020	Dec. 10, 2021
Horn Antenna 18G-40G	SCHWARZBECK	BBHA 9170	BBHA 9170517	Nov. 06, 2020	Nov. 05, 2021
Preamplifier	EMC	EMC02325	980225	Jun. 29, 2021	Jun. 28, 2022
Preamplifier	Agilent	83017A	MY39501308	Sep. 26, 2020	Sep. 25, 2021
Preamplifier	EMC	EMC184045B	980192	Jul. 14, 2021	Jul. 13, 2022
Loop Antenna Cable	KOAX KABEL	101354-BW	101354-BW	Oct. 06, 2020	Oct. 05, 2021
LF cable 3M	Woken	CFD400NL-LW	CFD400NL-001	Oct. 06, 2020	Oct. 05, 2021
LF cable 11M	EMC	EMCCFD400-NW-N W-11000	200801	Oct. 06, 2020	Oct. 05, 2021
LF cable 1M	EMC	EMCCFD400-NM-N M-1000	160502	Oct. 06, 2020	Oct. 05, 2021
RF Cable	HUBER+SUHNER	SUCOFLEX104	MY16019/4	Oct. 06, 2020	Oct. 05, 2021
RF Cable	HUBER+SUHNER	SUCOFLEX104	MY16014/4	Oct. 06, 2020	Oct. 05, 2021
Measurement Software	AUDIX	e3	6.120210g	NA	NA
Note: Calibration Interval of instruments listed above is one year.					

Test Item	RF Conducted				
Test Site	(TH01-WS)				
Tested Date	Aug. 24 ~ Aug. 30, 2021				
Instrument	Brand	Model No.	Serial No.	Calibration Date	Calibration Until
Spectrum Analyzer	R&S	FSV40	101063	Apr. 19, 2021	Apr. 18, 2022
Power Meter	Anritsu	ML2495A	1241002	Nov. 04, 2020	Nov. 03, 2021
Power Sensor	Anritsu	MA2411B	1207366	Nov. 04, 2020	Nov. 03, 2021
Spectrum Analyzer	R&S	FSV40	101063	Apr. 19, 2021	Apr. 18, 2022
Note: Calibration Interval of instruments listed above is one year.					

1.5 Test Standards

47 CFR FCC Part 15.247

ANSI C63.10-2013

1.6 Reference Guidance

FCC KDB 558074 D01 15.247 Meas Guidance v05r02

1.7 Deviation from Test Standard and Measurement Procedure

None

1.8 Measurement Uncertainty

The measurement uncertainties given below are based on a 95% confidence level (based on a coverage factor ($k=2$)).

Measurement Uncertainty	
Parameters	Uncertainty
Bandwidth	± 34.130 Hz
Conducted power	± 0.808 dB
Power density	± 0.583 dB
Radiated emission ≤ 1 GHz	± 3.41 dB
Radiated emission > 1 GHz	± 4.59 dB

2 Test Configuration

2.1 Testing Facility

Test Laboratory	International Certification Corp.
Test Site	CO01-WS, 03CH01-WS, TH01-WS
Address of Test Site	No. 3-1, Lane 6, Wen San 3rd St., Kwei Shan District, Tao Yuan City 333, Taiwan, R.O.C.

- FCC Designation No.: TW2732
- FCC site registration No.: 181692
- ISED#: 10807A
- CAB identifier: TW2732

2.2 The Worst Test Modes and Channel Details

Test item	Channel Bandwidth (kHz)	Test Frequency (MHz)	Separating Factor
Conducted Emissions Radiated Emissions Conducted Output Power	125	902.3 / 908.5 / 914.9	SF10
Hopping Channel Separation 20dB and Occupied bandwidth Power Spectral Density	500	903 / 907.8 / 914.2	SF8
Number of Hopping Channels	125	902.3 ~ 914.9	SF10
	500	903 ~ 914.2	SF8
Dwell Time	125	902.3	SF10, 9, 8, 7
	500	903	SF8

NOTE:

1. The EUT was pretested with 3 orientations placed on the table for the radiated emission measurement – X, Y, and Z-plane. The **Z-plane** result was found as the worst case and was shown in this report.

3 Transmitter Test Results

3.1 Conducted Emissions

3.1.1 Limit of Conducted Emissions

Conducted Emissions Limit		
Frequency Emission (MHz)	Quasi-Peak	Average
0.15-0.5	66 - 56 *	56 - 46 *
0.5-5	56	46
5-30	60	50

Note 1: * Decreases with the logarithm of the frequency.

3.1.2 Test Procedures

1. The device is placed on a test table, raised 80 cm above the reference ground plane. The vertical conducting plane is located 40 cm to the rear of the device.
2. The device is connected to line impedance stabilization network (LISN) and other accessories are connected to other LISN. Measured levels of AC power line conducted emission are across the 50 Ω LISN port.
3. AC conducted emission measurements is made over frequency range from 150 kHz to 30 MHz.
4. This measurement was performed with AC 120V / 60Hz.

3.1.3 Test Setup



- Note: 1. Support units were connected to second LISN.
 2. Both of LISNs (AMN) are 80 cm from EUT and at least 80 cm from other units and other metal planes

3.1.4 Test Result of Conducted Emissions

Channel Bandwidth 125kHz

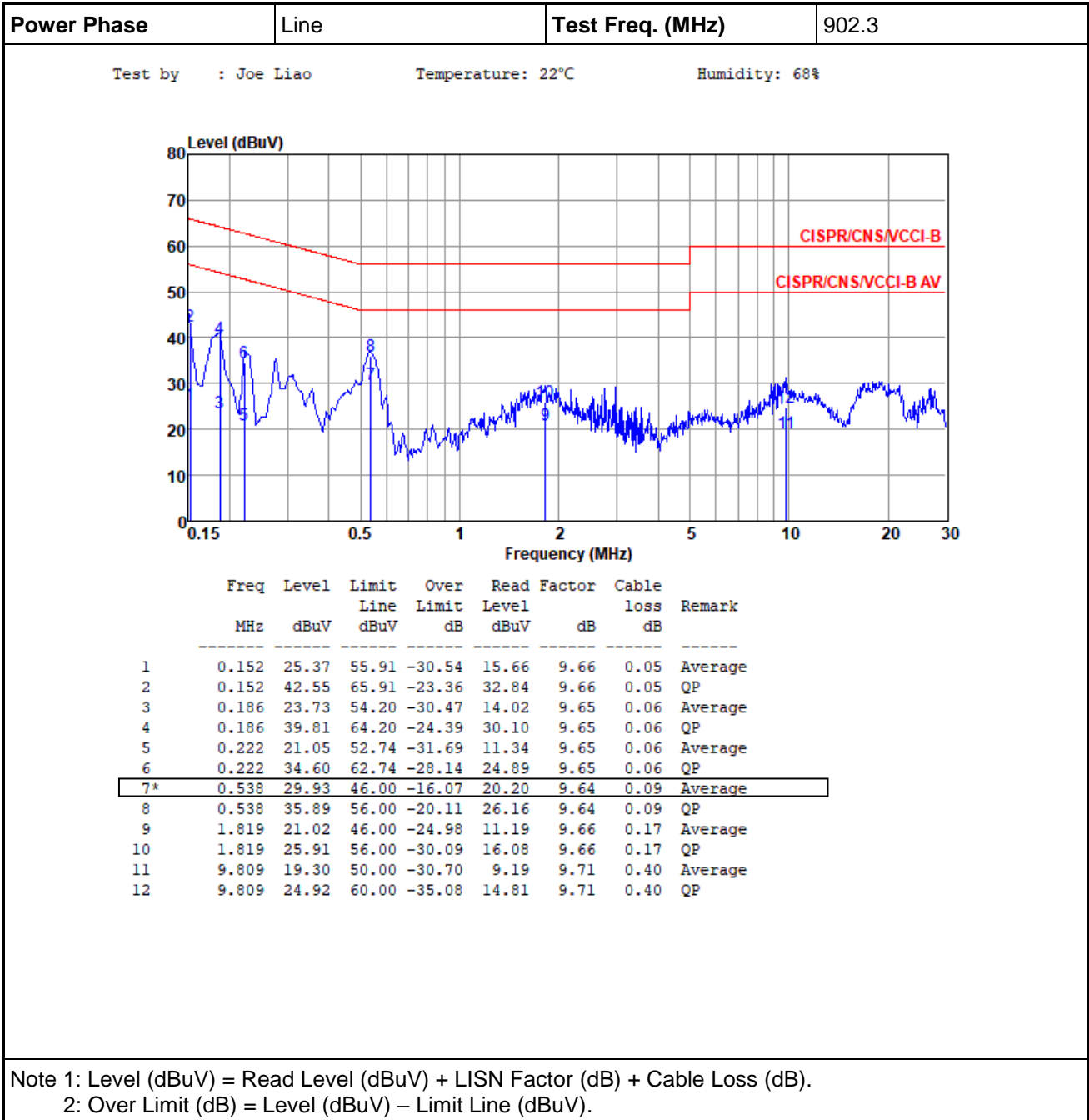

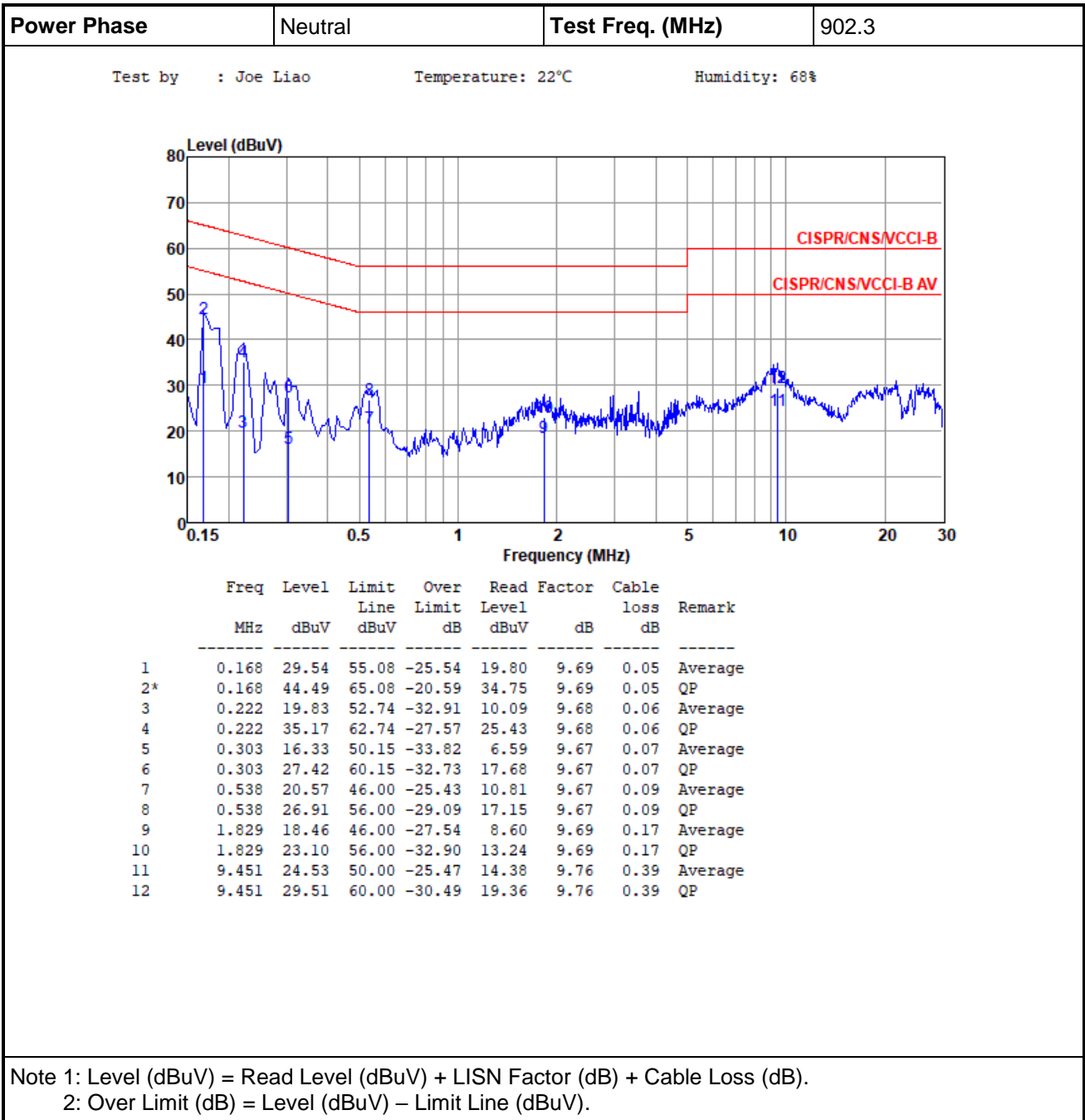

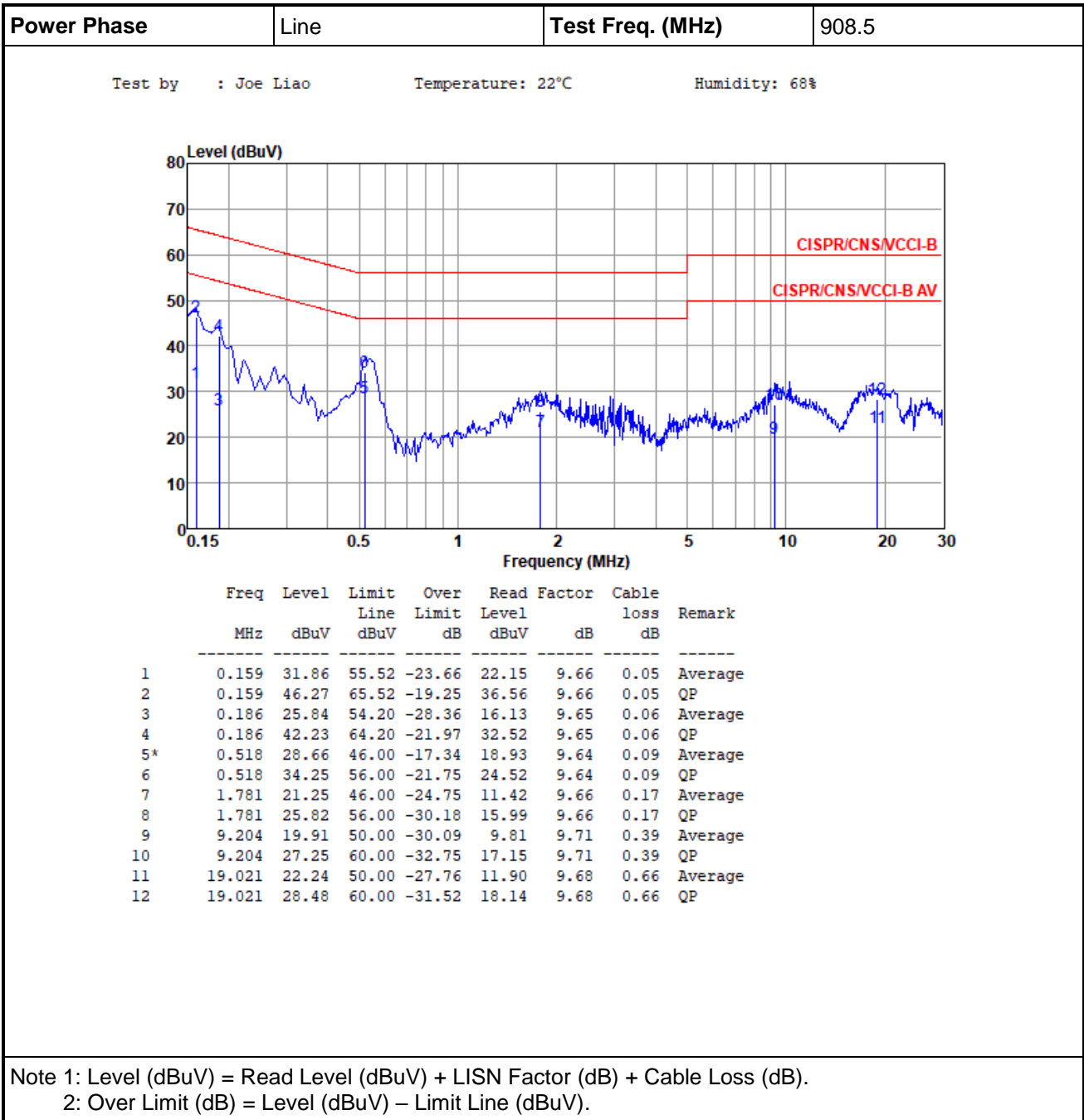

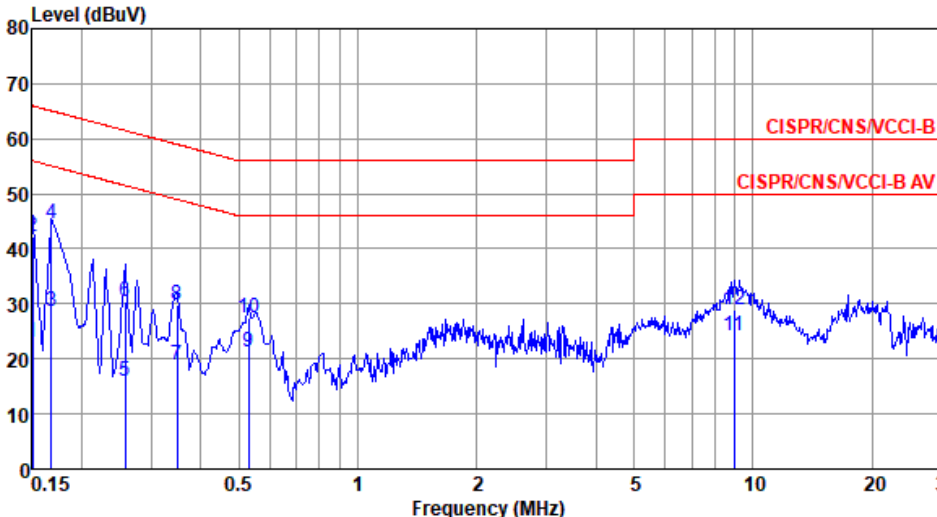
Power Phase	Neutral	Test Freq. (MHz)	908.5																																																																																																																																							
<p>Test by : Joe Liao Temperature: 22°C Humidity: 68%</p>																																																																																																																																										
																																																																																																																																										
<table border="1"> <thead> <tr> <th></th> <th>Freq</th> <th>Level</th> <th>Limit</th> <th>Over</th> <th>Read</th> <th>Factor</th> <th>Cable</th> <th>Remark</th> </tr> <tr> <th></th> <th>MHz</th> <th>dBuV</th> <th>Line</th> <th>Limit</th> <th>Level</th> <th>dB</th> <th>loss</th> <th></th> </tr> <tr> <th></th> <th></th> <th></th> <th>dBuV</th> <th>dB</th> <th>dBuV</th> <th></th> <th>dB</th> <th></th> </tr> </thead> <tbody> <tr> <td>1</td> <td>0.150</td> <td>23.08</td> <td>56.00</td> <td>-32.92</td> <td>13.34</td> <td>9.69</td> <td>0.05</td> <td>Average</td> </tr> <tr> <td>2</td> <td>0.150</td> <td>42.20</td> <td>66.00</td> <td>-23.80</td> <td>32.46</td> <td>9.69</td> <td>0.05</td> <td>QP</td> </tr> <tr> <td>3</td> <td>0.168</td> <td>28.75</td> <td>55.08</td> <td>-26.33</td> <td>19.01</td> <td>9.69</td> <td>0.05</td> <td>Average</td> </tr> <tr> <td>4*</td> <td>0.168</td> <td>44.49</td> <td>65.08</td> <td>-20.59</td> <td>34.75</td> <td>9.69</td> <td>0.05</td> <td>QP</td> </tr> <tr> <td>5</td> <td>0.258</td> <td>15.99</td> <td>51.51</td> <td>-35.52</td> <td>6.24</td> <td>9.68</td> <td>0.07</td> <td>Average</td> </tr> <tr> <td>6</td> <td>0.258</td> <td>30.30</td> <td>61.51</td> <td>-31.21</td> <td>20.55</td> <td>9.68</td> <td>0.07</td> <td>QP</td> </tr> <tr> <td>7</td> <td>0.348</td> <td>18.99</td> <td>49.00</td> <td>-30.01</td> <td>9.24</td> <td>9.67</td> <td>0.08</td> <td>Average</td> </tr> <tr> <td>8</td> <td>0.348</td> <td>29.83</td> <td>59.00</td> <td>-29.17</td> <td>20.08</td> <td>9.67</td> <td>0.08</td> <td>QP</td> </tr> <tr> <td>9</td> <td>0.529</td> <td>21.18</td> <td>46.00</td> <td>-24.82</td> <td>11.42</td> <td>9.67</td> <td>0.09</td> <td>Average</td> </tr> <tr> <td>10</td> <td>0.529</td> <td>27.45</td> <td>56.00</td> <td>-28.55</td> <td>17.69</td> <td>9.67</td> <td>0.09</td> <td>QP</td> </tr> <tr> <td>11</td> <td>8.964</td> <td>24.27</td> <td>50.00</td> <td>-25.73</td> <td>14.13</td> <td>9.75</td> <td>0.39</td> <td>Average</td> </tr> <tr> <td>12</td> <td>8.964</td> <td>29.06</td> <td>60.00</td> <td>-30.94</td> <td>18.92</td> <td>9.75</td> <td>0.39</td> <td>QP</td> </tr> </tbody> </table>					Freq	Level	Limit	Over	Read	Factor	Cable	Remark		MHz	dBuV	Line	Limit	Level	dB	loss					dBuV	dB	dBuV		dB		1	0.150	23.08	56.00	-32.92	13.34	9.69	0.05	Average	2	0.150	42.20	66.00	-23.80	32.46	9.69	0.05	QP	3	0.168	28.75	55.08	-26.33	19.01	9.69	0.05	Average	4*	0.168	44.49	65.08	-20.59	34.75	9.69	0.05	QP	5	0.258	15.99	51.51	-35.52	6.24	9.68	0.07	Average	6	0.258	30.30	61.51	-31.21	20.55	9.68	0.07	QP	7	0.348	18.99	49.00	-30.01	9.24	9.67	0.08	Average	8	0.348	29.83	59.00	-29.17	20.08	9.67	0.08	QP	9	0.529	21.18	46.00	-24.82	11.42	9.67	0.09	Average	10	0.529	27.45	56.00	-28.55	17.69	9.67	0.09	QP	11	8.964	24.27	50.00	-25.73	14.13	9.75	0.39	Average	12	8.964	29.06	60.00	-30.94	18.92	9.75	0.39	QP
	Freq	Level	Limit	Over	Read	Factor	Cable	Remark																																																																																																																																		
	MHz	dBuV	Line	Limit	Level	dB	loss																																																																																																																																			
			dBuV	dB	dBuV		dB																																																																																																																																			
1	0.150	23.08	56.00	-32.92	13.34	9.69	0.05	Average																																																																																																																																		
2	0.150	42.20	66.00	-23.80	32.46	9.69	0.05	QP																																																																																																																																		
3	0.168	28.75	55.08	-26.33	19.01	9.69	0.05	Average																																																																																																																																		
4*	0.168	44.49	65.08	-20.59	34.75	9.69	0.05	QP																																																																																																																																		
5	0.258	15.99	51.51	-35.52	6.24	9.68	0.07	Average																																																																																																																																		
6	0.258	30.30	61.51	-31.21	20.55	9.68	0.07	QP																																																																																																																																		
7	0.348	18.99	49.00	-30.01	9.24	9.67	0.08	Average																																																																																																																																		
8	0.348	29.83	59.00	-29.17	20.08	9.67	0.08	QP																																																																																																																																		
9	0.529	21.18	46.00	-24.82	11.42	9.67	0.09	Average																																																																																																																																		
10	0.529	27.45	56.00	-28.55	17.69	9.67	0.09	QP																																																																																																																																		
11	8.964	24.27	50.00	-25.73	14.13	9.75	0.39	Average																																																																																																																																		
12	8.964	29.06	60.00	-30.94	18.92	9.75	0.39	QP																																																																																																																																		
<p>Note 1: Level (dBuV) = Read Level (dBuV) + LISN Factor (dB) + Cable Loss (dB). Note 2: Over Limit (dB) = Level (dBuV) – Limit Line (dBuV).</p>																																																																																																																																										

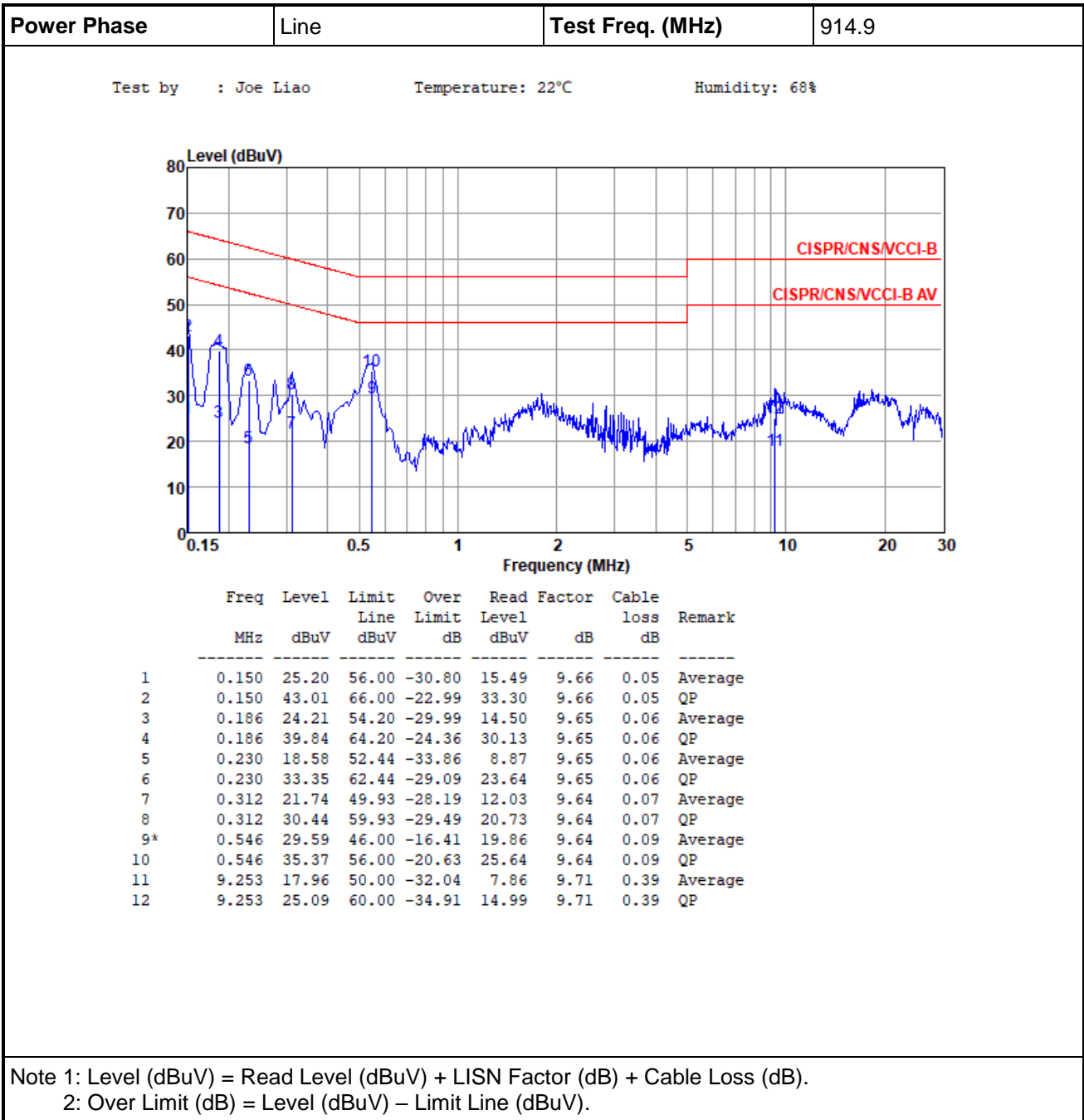

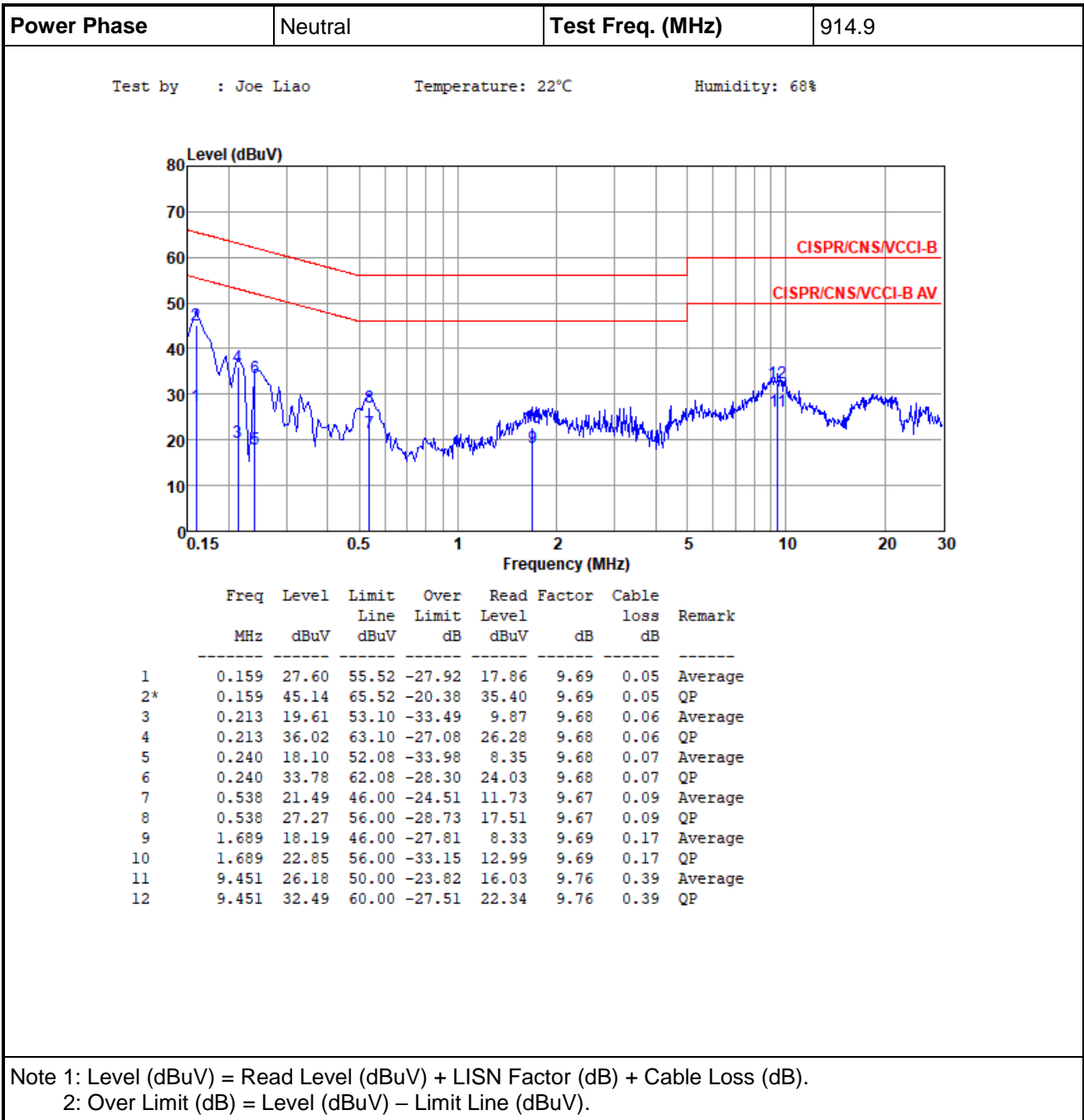

Channel Bandwidth 500kHz

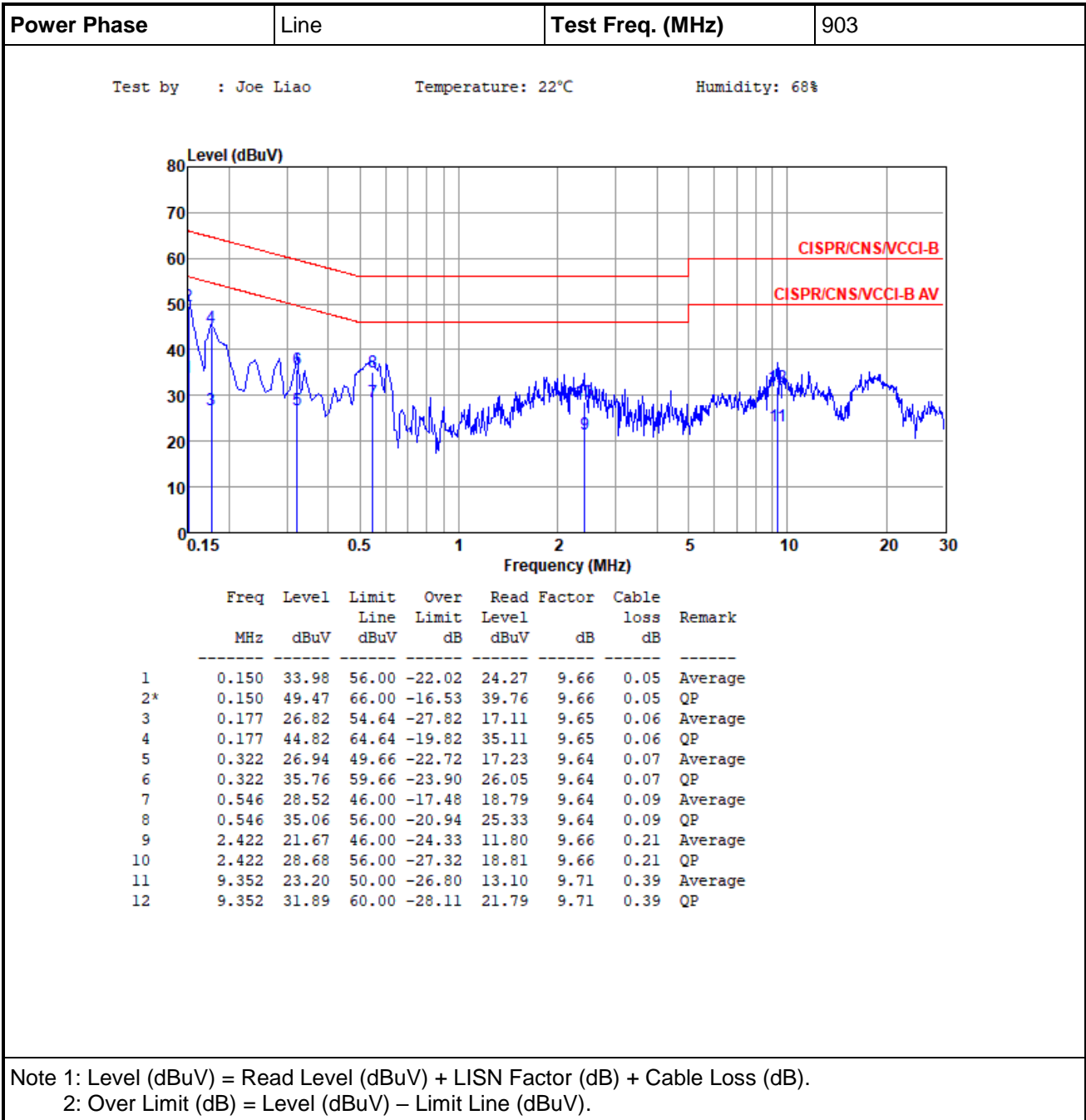

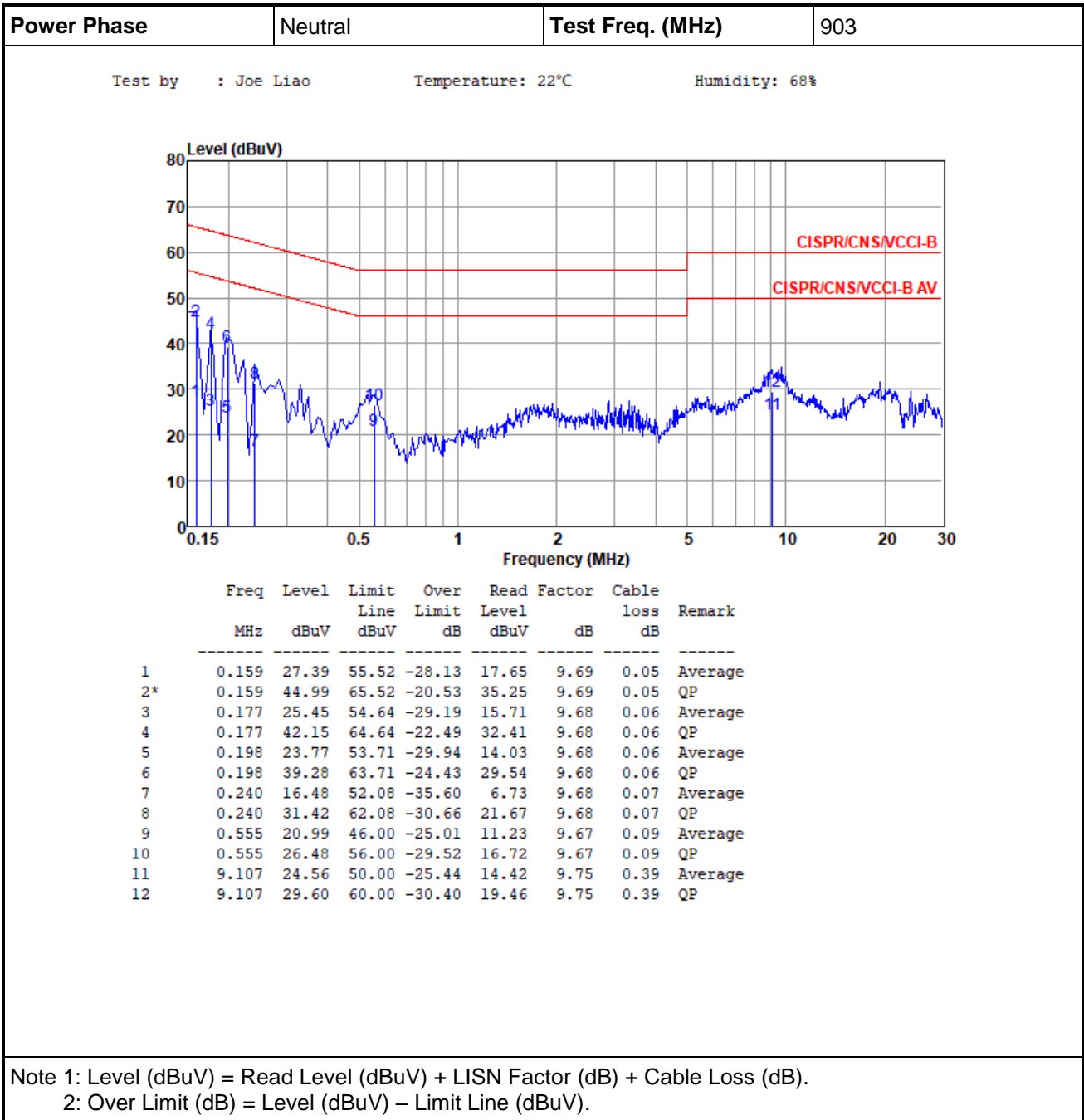

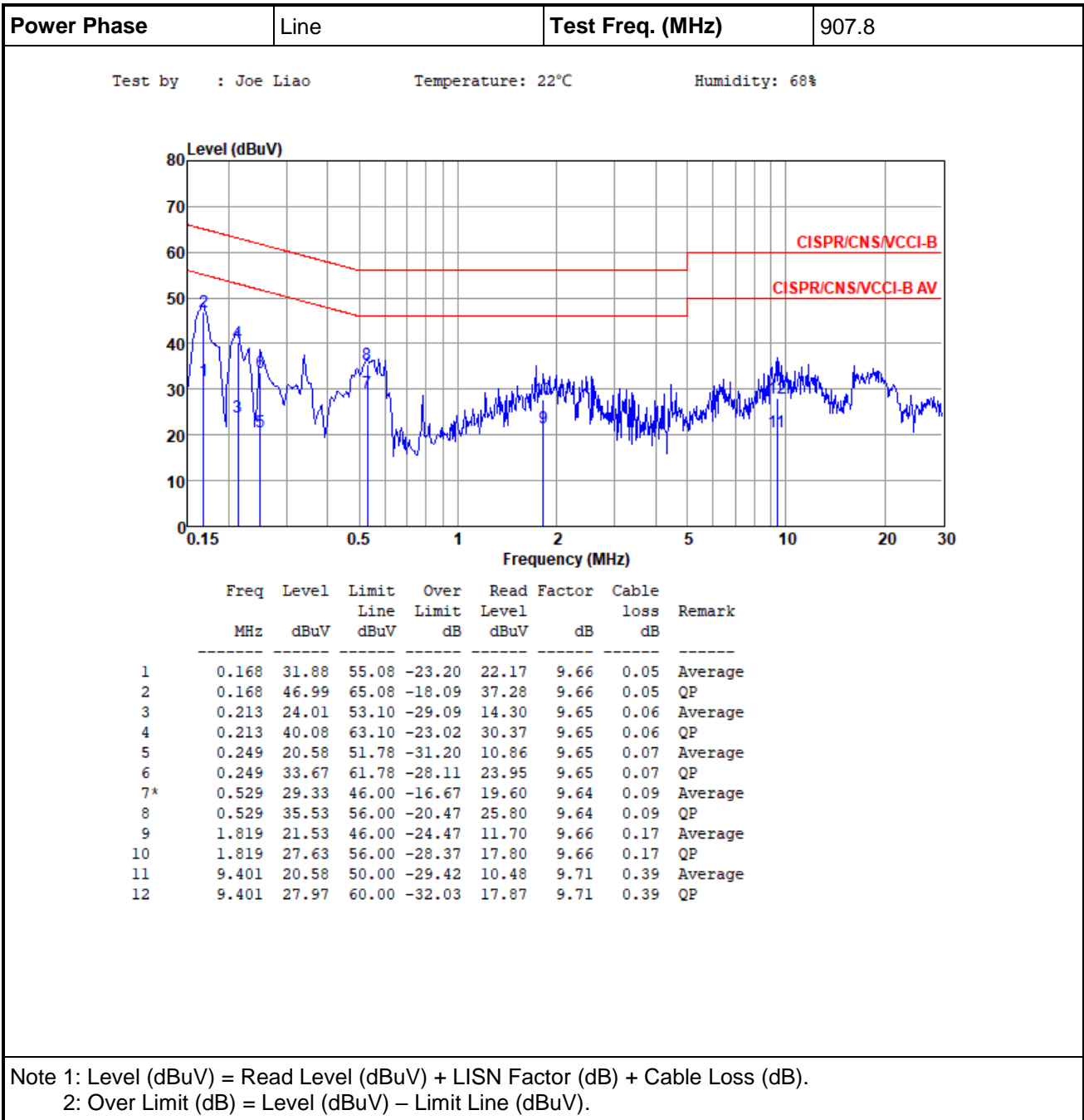

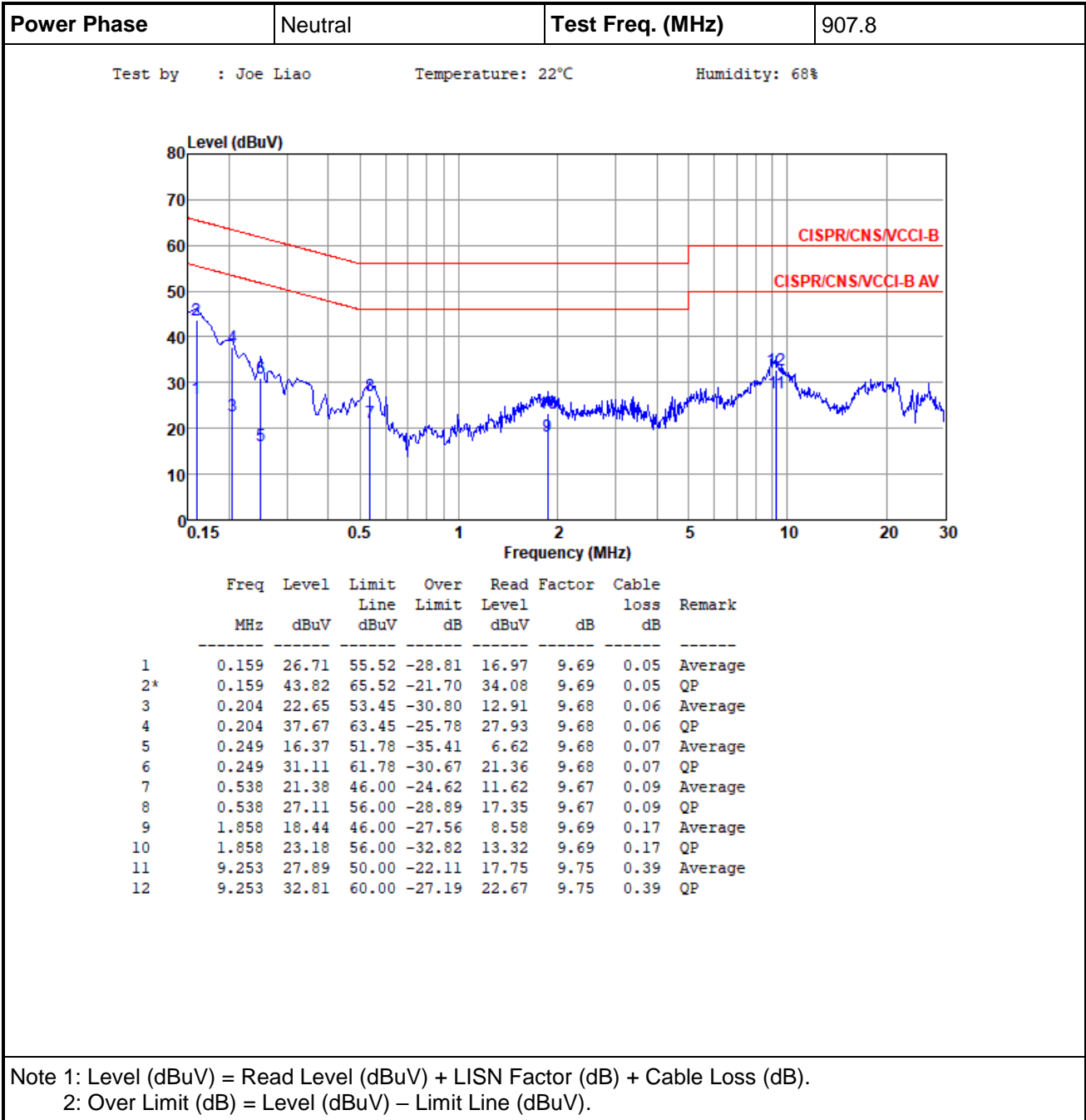

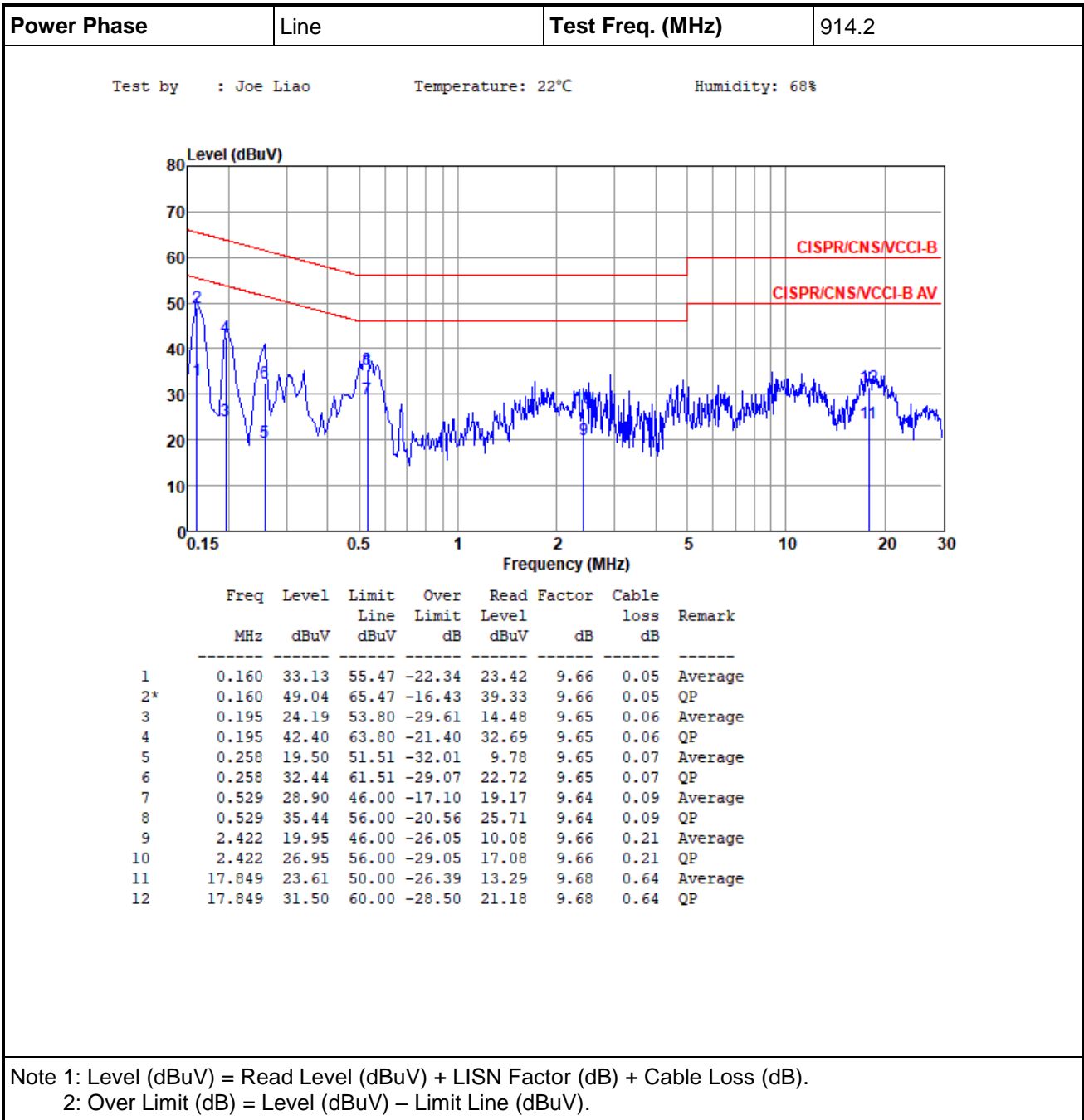

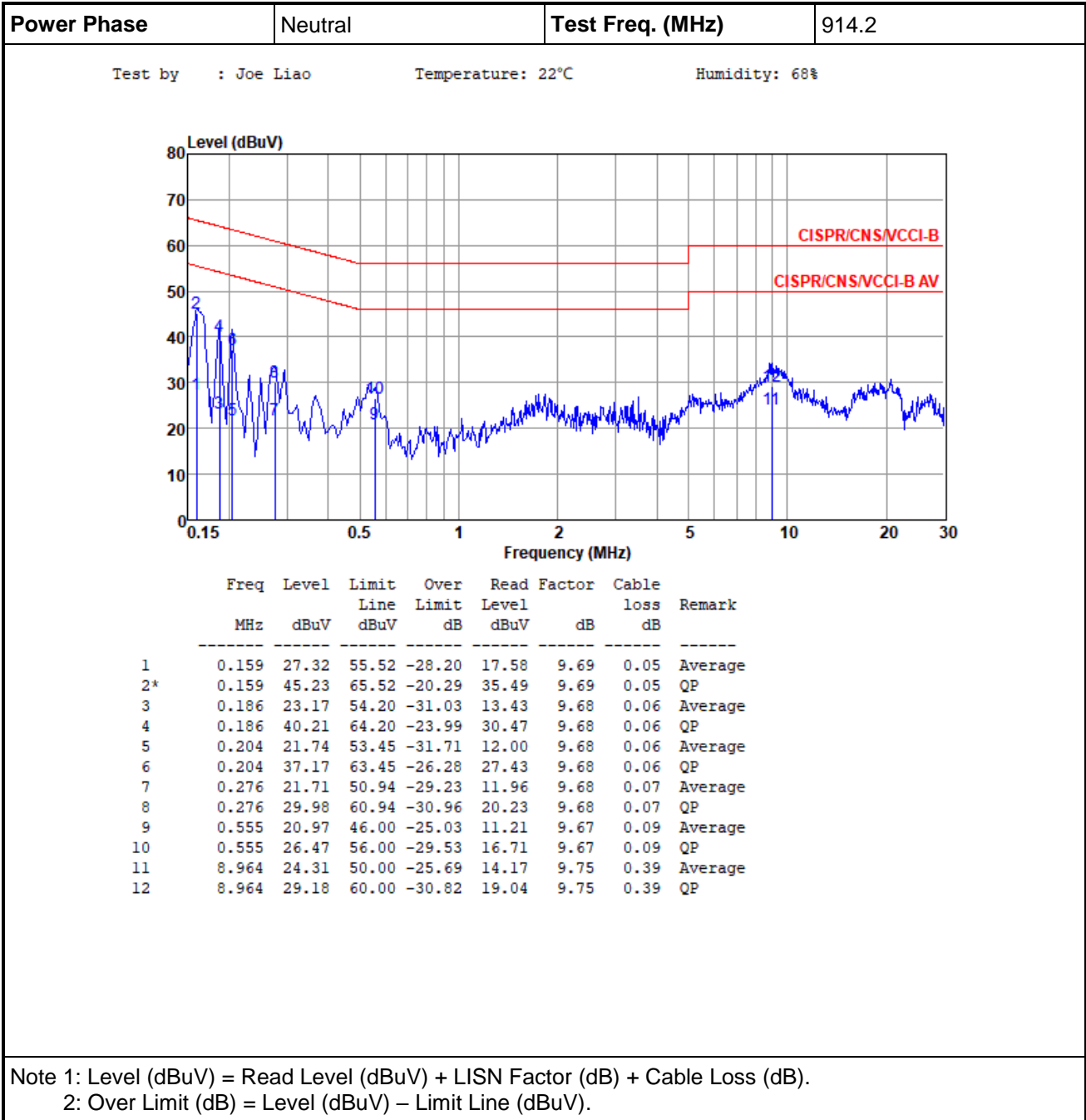

3.2 Unwanted Emissions into Restricted Frequency Bands

3.2.1 Limit of Unwanted Emissions into Restricted Frequency Bands

Restricted Band Emissions Limit			
Frequency Range (MHz)	Field Strength (uV/m)	Field Strength (dBuV/m)	Measure Distance (m)
0.009~0.490	2400/F(kHz)	48.5 - 13.8	300
0.490~1.705	24000/F(kHz)	33.8 - 23	30
1.705~30.0	30	29	30
30~88	100	40	3
88~216	150	43.5	3
216~960	200	46	3
Above 960	500	54	3

Note 1:
Quasi-Peak value is measured for frequency below 1GHz except for 9–90 kHz, 110–490 kHz frequency band. Peak and average value are measured for frequency above 1GHz. The limit on average radio frequency emission is as above table. The limit on peak radio frequency emissions is 20 dB above the maximum permitted average emission limit

Note 2:
Measurements may be performed at a distance other than what is specified provided. When performing measurements at a distance other than that specified, the results shall be extrapolated to the specified distance using an extrapolation factor as below, Frequency at or above 30 MHz: 20 dB/decade Frequency below 30 MHz: 40 dB/decade.

3.2.2 Test Procedures

1. Measurement is made at a semi-anechoic chamber that incorporates a turntable allowing a EUT rotation of 360°. A continuously-rotating, remotely-controlled turntable is installed at the test site to support the EUT and facilitate determination of the direction of maximum radiation for each EUT emission frequency. The EUT is placed at test table. For emissions testing at or below 1 GHz, the table height is 80 cm above the reference ground plane. For emission measurements above 1 GHz, the table height is 1.5 m
2. Measurement is made with the antenna positioned in both the horizontal and vertical planes of polarization. The measurement antenna is varied in height (1m ~ 4m) above the reference ground plane to obtain the maximum signal strength. Distance between EUT and antenna is 3 m.
3. This investigation is performed with the EUT rotated 360°, the antenna height scanned between 1 m and 4 m, and the antenna rotated to repeat the measurements for both the horizontal and vertical antenna polarizations.

Note:

1. 120kHz measurement bandwidth of test receiver and Quasi-peak detector is for radiated emission below 1GHz.
2. RBW=1MHz, VBW=3MHz and Peak detector is for peak measured value of radiated emission above 1GHz.
3. RBW=1MHz, VBW=1/T and Peak detector is for average measured value of radiated emission above 1GHz.

3.2.3 Test Setup

Radiated Emissions below 1 GHz

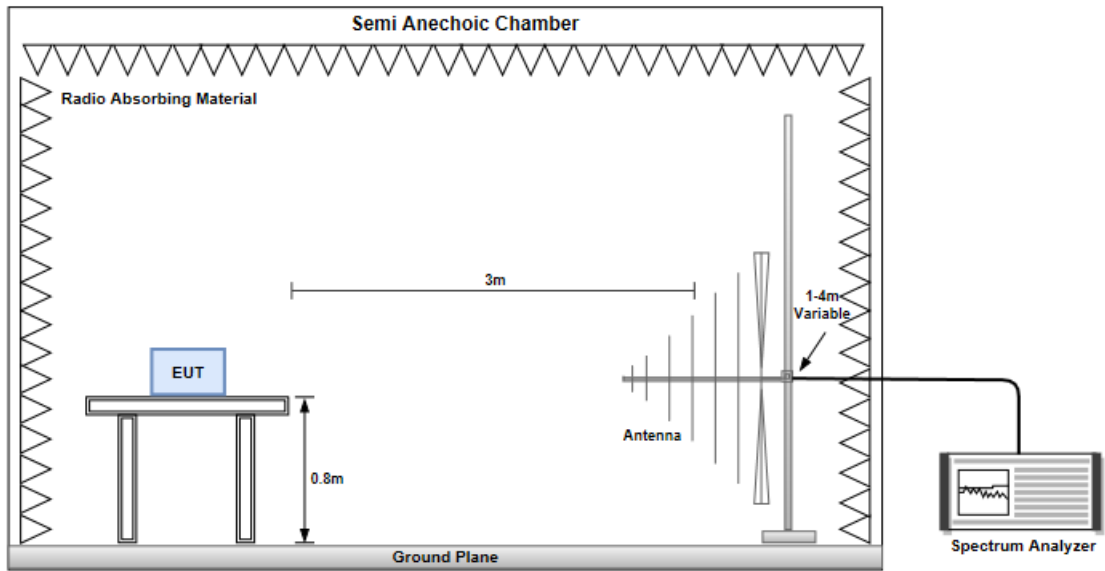

Radiated Emissions above 1 GHz

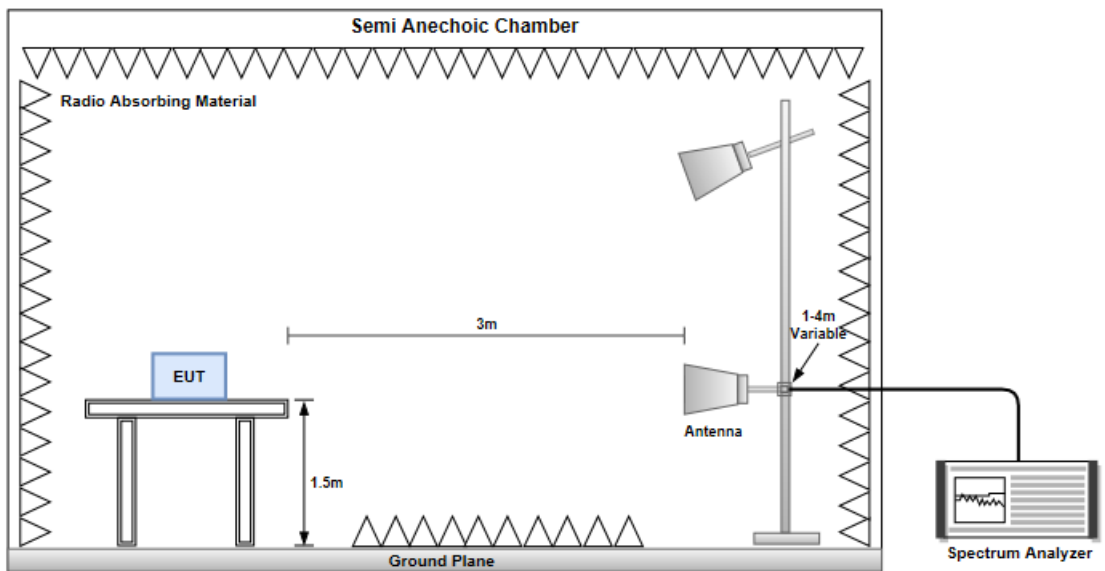

Channel Bandwidth 125kHz

3.2.4 Transmitter Radiated Unwanted Emissions (Below 1GHz)

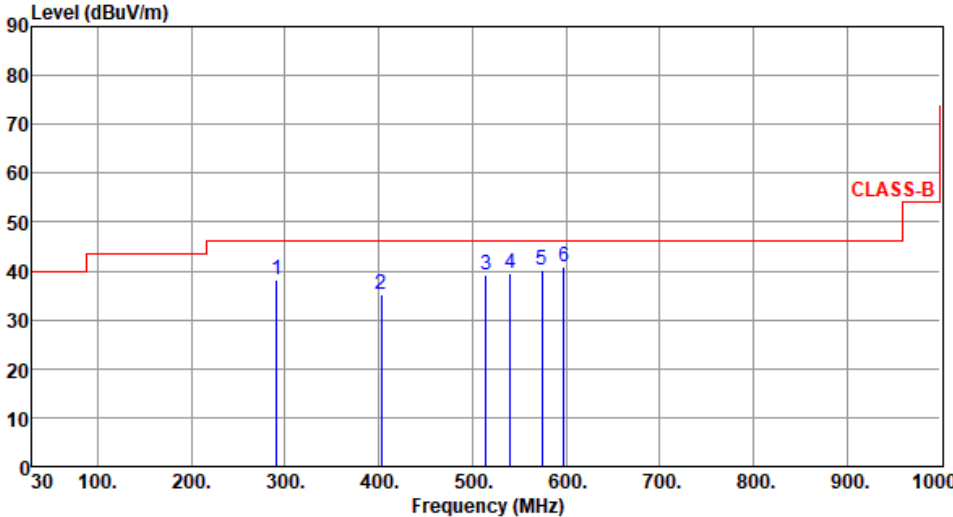
Polarization	Horizontal		Test Freq. (MHz)	902.3					
Test By	:Brad Wu		Temperature(°C):24	Humidity(%):64					
 <p>The graph plots Level (dBuV/m) on the y-axis (0 to 90) against Frequency (MHz) on the x-axis (30 to 1000). A red step function represents the CLASS-B limit, starting at 40 dBuV/m from 30 MHz to 100 MHz, rising to 45 dBuV/m at 200 MHz, and rising to 55 dBuV/m at 900 MHz. Six blue vertical lines indicate emission peaks at 291.20 MHz (1), 403.20 MHz (2), 514.40 MHz (3), 540.80 MHz (4), 574.40 MHz (5), and 597.60 MHz (6). All peaks are below the 46 dBuV/m limit.</p>									
	Freq.	Emission level	Limit	Margin	SA reading	Factor	Remark	ANT High	Turn Table
	MHz	dBuV/m	dBuV/m	dB	dBuV	dB/m		cm	deg
1	291.20	38.31	46.00	-7.69	46.73	-8.42	Peak	---	---
2	403.20	35.17	46.00	-10.83	40.96	-5.79	Peak	---	---
3	514.40	39.29	46.00	-6.71	42.32	-3.03	Peak	---	---
4	540.80	39.57	46.00	-6.43	42.32	-2.75	Peak	---	---
5	574.40	40.15	46.00	-5.85	42.04	-1.89	Peak	---	---
6	597.60	40.71	46.00	-5.29	41.98	-1.27	Peak	---	---
<p>Note 1: Emission Level (dBuV/m) = SA Reading (dBuV/m) + Factor* (dB) *Factor includes antenna factor , cable loss and amplifier gain Note 2: Margin (dB) = Emission level (dBuV/m) – Limit (dBuV/m).</p>									

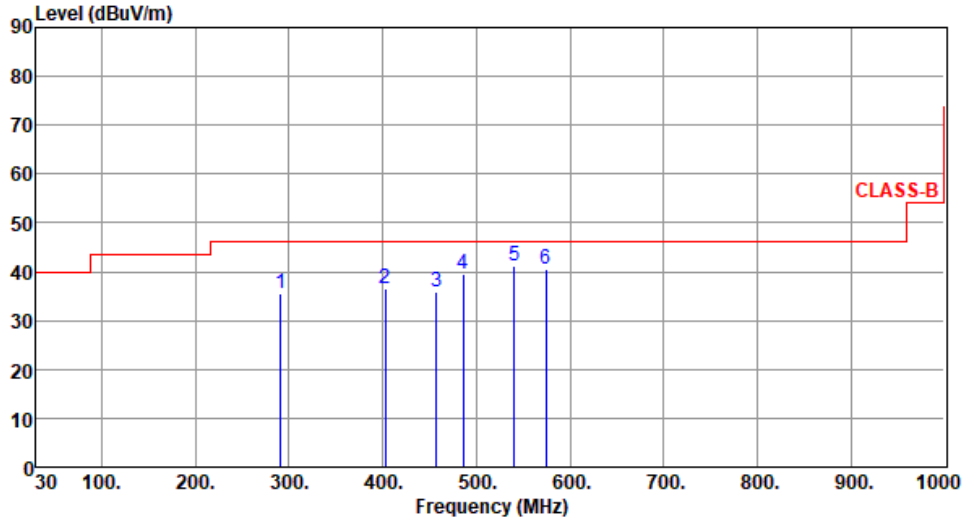
Polarization	Vertical	Test Freq. (MHz)	902.3						
Test By	:Brad Wu	Temperature(°C):24	Humidity(%):64						
									
	Freq. MHz	Emission level dBuV/m	Limit dBuV/m	Margin dB	SA reading dBuV	Factor dB/m	Remark	ANT High cm	Turn Table deg
1	291.20	35.60	46.00	-10.40	44.02	-8.42	Peak	---	---
2	403.20	36.41	46.00	-9.59	42.20	-5.79	Peak	---	---
3	457.60	36.00	46.00	-10.00	40.17	-4.17	Peak	---	---
4	486.40	39.57	46.00	-6.43	43.34	-3.77	Peak	---	---
5	540.80	41.10	46.00	-4.90	43.85	-2.75	Peak	---	---
6	574.40	40.65	46.00	-5.35	42.54	-1.89	Peak	---	---
<p>Note 1: Emission Level (dBuV/m) = SA Reading (dBuV/m) + Factor* (dB) *Factor includes antenna factor , cable loss and amplifier gain Note 2: Margin (dB) = Emission level (dBuV/m) – Limit (dBuV/m).</p>									

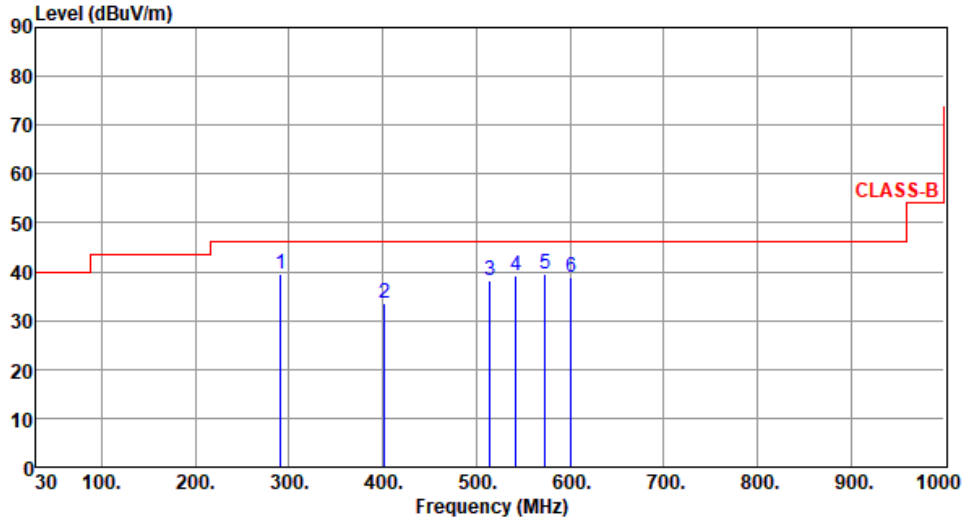
Polarization	Horizontal	Test Freq. (MHz)	908.5						
Test By	:Brad Wu	Temperature(°C):24	Humidity(%) :64						
									
	Freq. MHz	Emission level dBuV/m	Limit dBuV/m	Margin dB	SA reading dBuV	Factor dB/m	Remark	ANT High cm	Turn Table deg
1	291.20	39.50	46.00	-6.50	47.92	-8.42	Peak	---	---
2	401.60	33.42	46.00	-12.58	39.25	-5.83	Peak	---	---
3	514.40	38.27	46.00	-7.73	41.30	-3.03	Peak	---	---
4	542.40	39.32	46.00	-6.68	42.07	-2.75	Peak	---	---
5	573.60	39.52	46.00	-6.48	41.43	-1.91	Peak	---	---
6	600.80	38.97	46.00	-7.03	40.10	-1.13	Peak	---	---
<p>Note 1: Emission Level (dBuV/m) = SA Reading (dBuV/m) + Factor* (dB) *Factor includes antenna factor , cable loss and amplifier gain Note 2: Margin (dB) = Emission level (dBuV/m) – Limit (dBuV/m).</p>									

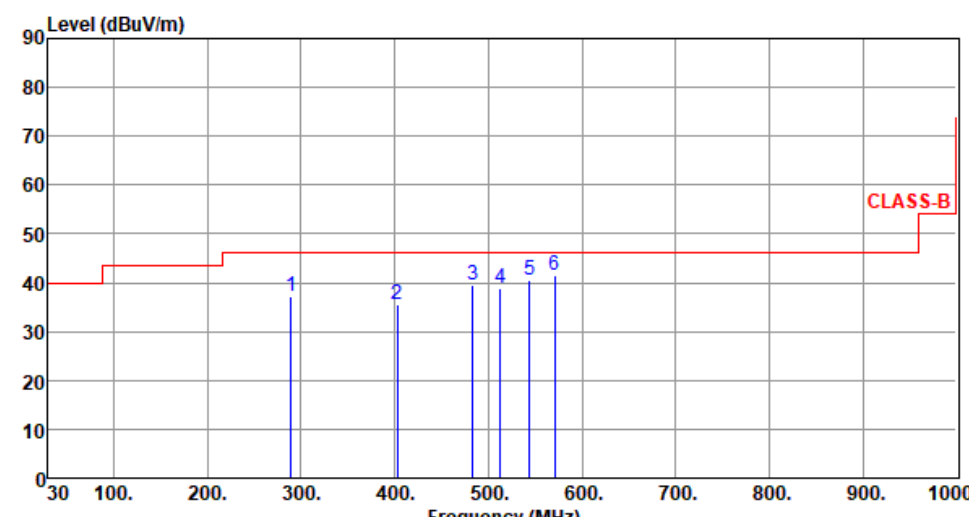
Polarization	Vertical	Test Freq. (MHz)	908.5						
Test By	:Brad Wu	Temperature(°C):24	Humidity(%):64						
									
	Freq. MHz	Emission level dBUV/m	Limit dBUV/m	Margin dB	SA reading dBUV	Factor dB/m	Remark	ANT High cm	Turn Table deg
1	289.60	37.24	46.00	-8.76	45.70	-8.46	Peak	---	---
2	403.20	35.48	46.00	-10.52	41.27	-5.79	Peak	---	---
3	483.20	39.59	46.00	-6.41	43.40	-3.81	Peak	---	---
4	512.80	38.85	46.00	-7.15	41.91	-3.06	Peak	---	---
5	544.00	40.46	46.00	-5.54	43.20	-2.74	Peak	---	---
6	571.20	41.63	46.00	-4.37	43.59	-1.96	Peak	---	---
<p>Note 1: Emission Level (dBUV/m) = SA Reading (dBUV/m) + Factor* (dB) *Factor includes antenna factor , cable loss and amplifier gain Note 2: Margin (dB) = Emission level (dBUV/m) – Limit (dBUV/m).</p>									

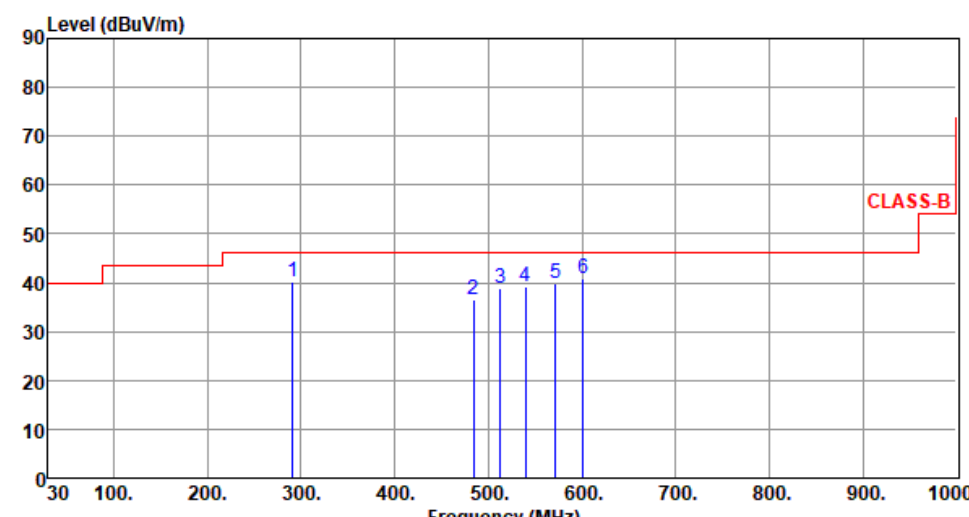
Polarization	Horizontal		Test Freq. (MHz)	914.9					
Test By	:Brad Wu		Temperature(°C):24	Humidity(%):64					
									
	Freq.	Emission level	Limit	Margin	SA reading	Factor	Remark	ANT High	Turn Table
	MHz	dBuV/m	dBuV/m	dB	dBuV	dB/m		cm	deg
1	291.20	40.32	46.00	-5.68	48.74	-8.42	Peak	---	---
2	484.00	36.42	46.00	-9.58	40.23	-3.81	Peak	---	---
3	512.80	38.93	46.00	-7.07	41.99	-3.06	Peak	---	---
4	540.00	39.04	46.00	-6.96	41.79	-2.75	Peak	---	---
5	572.00	39.91	46.00	-6.09	41.85	-1.94	Peak	---	---
6	600.80	40.89	46.00	-5.11	42.02	-1.13	Peak	---	---
<p>Note 1: Emission Level (dBuV/m) = SA Reading (dBuV/m) + Factor* (dB) *Factor includes antenna factor , cable loss and amplifier gain Note 2: Margin (dB) = Emission level (dBuV/m) – Limit (dBuV/m).</p>									

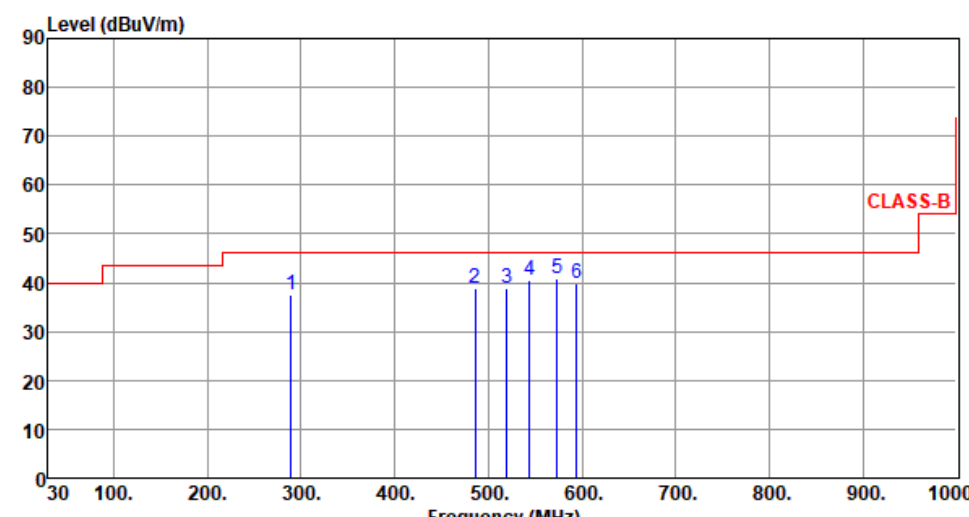
Polarization	Vertical	Test Freq. (MHz)	914.9						
Test By	:Brad Wu	Temperature(°C):24	Humidity(%):64						
									
	Freq. MHz	Emission level dBuV/m	Limit dBuV/m	Margin dB	SA reading dBuV	Factor dB/m	Remark	ANT High cm	Turn Table deg
1	289.60	37.51	46.00	-8.49	45.97	-8.46	Peak	---	---
2	486.40	38.75	46.00	-7.25	42.52	-3.77	Peak	---	---
3	520.00	38.90	46.00	-7.10	41.91	-3.01	Peak	---	---
4	544.00	40.62	46.00	-5.38	43.36	-2.74	Peak	---	---
5	573.60	40.95	46.00	-5.05	42.86	-1.91	Peak	---	---
6	594.40	39.69	46.00	-6.31	41.13	-1.44	Peak	---	---
<p>Note 1: Emission Level (dBuV/m) = SA Reading (dBuV/m) + Factor* (dB) *Factor includes antenna factor , cable loss and amplifier gain Note 2: Margin (dB) = Emission level (dBuV/m) – Limit (dBuV/m).</p>									

3.2.5 Transmitter Radiated Unwanted Emissions (Above 1GHz)

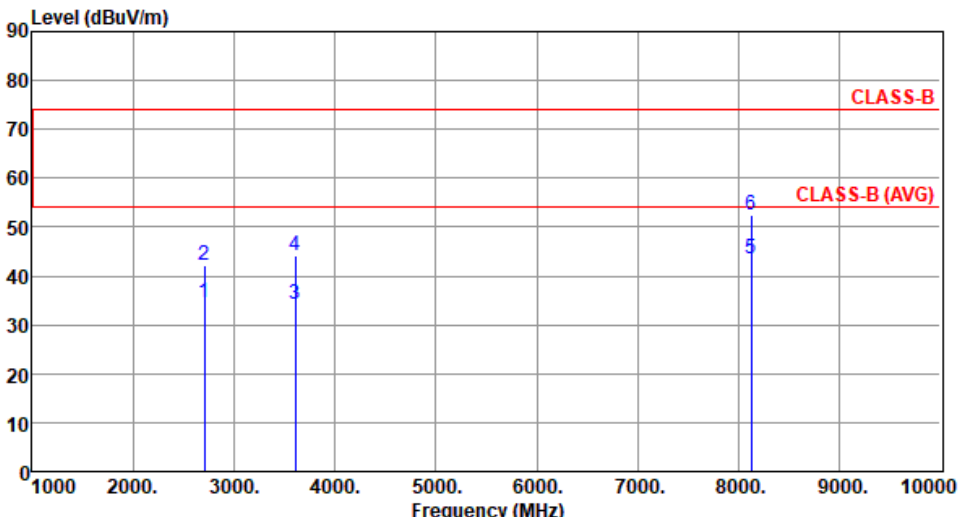
Polarization	Horizontal		Test Freq. (MHz)	902.3					
Test By	:Akun Chung		Temperature(°C):24	Humidity(%):64					
									
	Freq.	Emission level	Limit	Margin	SA reading	Factor	Remark	ANT High	Turn Table
	MHz	dBuV/m	dBuV/m	dB	dBuV	dB/m		cm	deg
1	2706.90	34.70	54.00	-19.30	36.89	-2.19	Average	372	79
2	2706.90	42.03	74.00	-31.97	44.22	-2.19	Peak	372	79
3	3609.20	34.15	54.00	-19.85	33.95	0.20	Average	156	45
4	3609.20	44.16	74.00	-29.84	43.96	0.20	Peak	156	45
5	8120.70	43.56	54.00	-10.44	33.87	9.69	Average	128	29
6	8120.70	52.57	74.00	-21.43	42.88	9.69	Peak	128	29

Note 1: Emission Level (dBuV/m) = SA Reading (dBuV/m) + Factor* (dB)
 *Factor includes antenna factor , cable loss and amplifier gain
 Note 2: Margin (dB) = Emission level (dBuV/m) – Limit (dBuV/m).

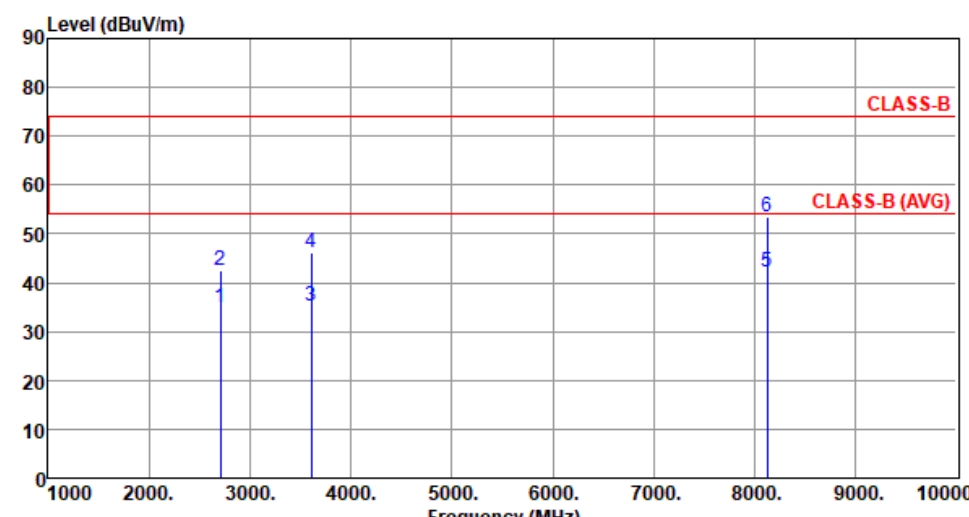
Polarization	Vertical	Test Freq. (MHz)	902.3																																																																												
Test By	:Akun Chung	Temperature(°C):24	Humidity(%) :64																																																																												
																																																																															
	<table border="1"> <thead> <tr> <th></th> <th>Freq. MHz</th> <th>Emission level dBUV/m</th> <th>Limit dBUV/m</th> <th>Margin dB</th> <th>SA reading dBUV</th> <th>Factor dB/m</th> <th>Remark</th> <th>ANT High cm</th> <th>Turn Table deg</th> </tr> </thead> <tbody> <tr> <td>1</td> <td>2706.90</td> <td>34.93</td> <td>54.00</td> <td>-19.07</td> <td>37.12</td> <td>-2.19</td> <td>Average</td> <td>195</td> <td>341</td> </tr> <tr> <td>2</td> <td>2706.90</td> <td>42.45</td> <td>74.00</td> <td>-31.55</td> <td>44.64</td> <td>-2.19</td> <td>Peak</td> <td>195</td> <td>341</td> </tr> <tr> <td>3</td> <td>3609.20</td> <td>35.05</td> <td>54.00</td> <td>-18.95</td> <td>34.85</td> <td>0.20</td> <td>Average</td> <td>100</td> <td>177</td> </tr> <tr> <td>4</td> <td>3609.20</td> <td>46.08</td> <td>74.00</td> <td>-27.92</td> <td>45.88</td> <td>0.20</td> <td>Peak</td> <td>100</td> <td>177</td> </tr> <tr> <td>5</td> <td>8120.70</td> <td>42.31</td> <td>54.00</td> <td>-11.69</td> <td>32.62</td> <td>9.69</td> <td>Average</td> <td>100</td> <td>235</td> </tr> <tr> <td>6</td> <td>8120.70</td> <td>53.34</td> <td>74.00</td> <td>-20.66</td> <td>43.65</td> <td>9.69</td> <td>Peak</td> <td>100</td> <td>235</td> </tr> </tbody> </table>		Freq. MHz	Emission level dBUV/m	Limit dBUV/m	Margin dB	SA reading dBUV	Factor dB/m	Remark	ANT High cm	Turn Table deg	1	2706.90	34.93	54.00	-19.07	37.12	-2.19	Average	195	341	2	2706.90	42.45	74.00	-31.55	44.64	-2.19	Peak	195	341	3	3609.20	35.05	54.00	-18.95	34.85	0.20	Average	100	177	4	3609.20	46.08	74.00	-27.92	45.88	0.20	Peak	100	177	5	8120.70	42.31	54.00	-11.69	32.62	9.69	Average	100	235	6	8120.70	53.34	74.00	-20.66	43.65	9.69	Peak	100	235								
	Freq. MHz	Emission level dBUV/m	Limit dBUV/m	Margin dB	SA reading dBUV	Factor dB/m	Remark	ANT High cm	Turn Table deg																																																																						
1	2706.90	34.93	54.00	-19.07	37.12	-2.19	Average	195	341																																																																						
2	2706.90	42.45	74.00	-31.55	44.64	-2.19	Peak	195	341																																																																						
3	3609.20	35.05	54.00	-18.95	34.85	0.20	Average	100	177																																																																						
4	3609.20	46.08	74.00	-27.92	45.88	0.20	Peak	100	177																																																																						
5	8120.70	42.31	54.00	-11.69	32.62	9.69	Average	100	235																																																																						
6	8120.70	53.34	74.00	-20.66	43.65	9.69	Peak	100	235																																																																						
<p>Note 1: Emission Level (dBUV/m) = SA Reading (dBUV/m) + Factor* (dB) *Factor includes antenna factor , cable loss and amplifier gain Note 2: Margin (dB) = Emission level (dBUV/m) – Limit (dBUV/m).</p>																																																																															

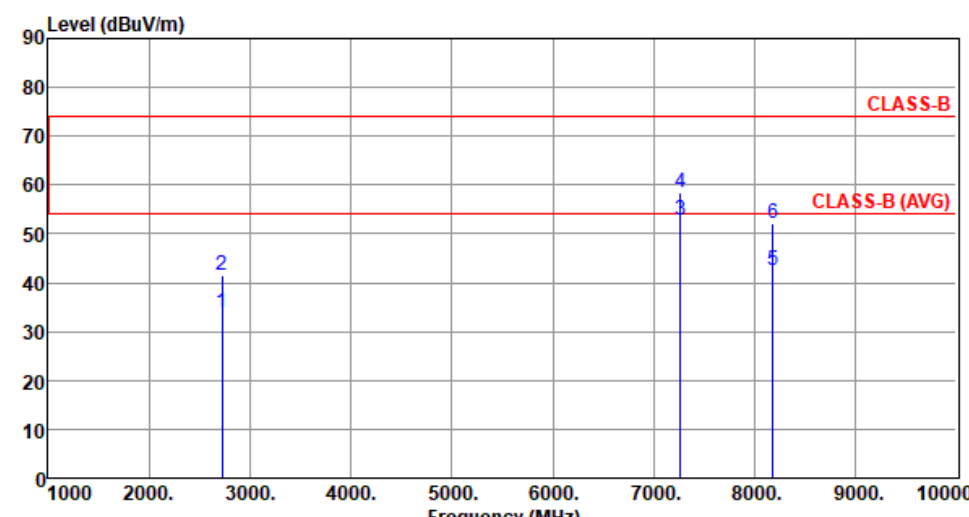
Polarization	Horizontal		Test Freq. (MHz)	908.5					
Test By	:Akun Chung		Temperature(°C):24	Humidity(%):64					
									
	Freq.	Emission level	Limit	Margin	SA reading	Factor	Remark	ANT High	Turn Table
	MHz	dBuV/m	dBuV/m	dB	dBuV	dB/m		cm	deg
1	2725.50	33.72	54.00	-20.28	35.77	-2.05	Average	388	85
2	2725.50	41.64	74.00	-32.36	43.69	-2.05	Peak	388	85
3	7268.00	52.74	54.00	-1.26	43.74	9.00	Average	366	39
4	7268.00	58.42	74.00	-15.58	49.42	9.00	Peak	366	39
5	8176.50	42.43	54.00	-11.57	32.93	9.50	Average	167	35
6	8176.50	52.27	74.00	-21.73	42.77	9.50	Peak	167	35

Note 1: Emission Level (dBuV/m) = SA Reading (dBuV/m) + Factor* (dB)

*Factor includes antenna factor , cable loss and amplifier gain

Note 2: Margin (dB) = Emission level (dBuV/m) – Limit (dBuV/m).

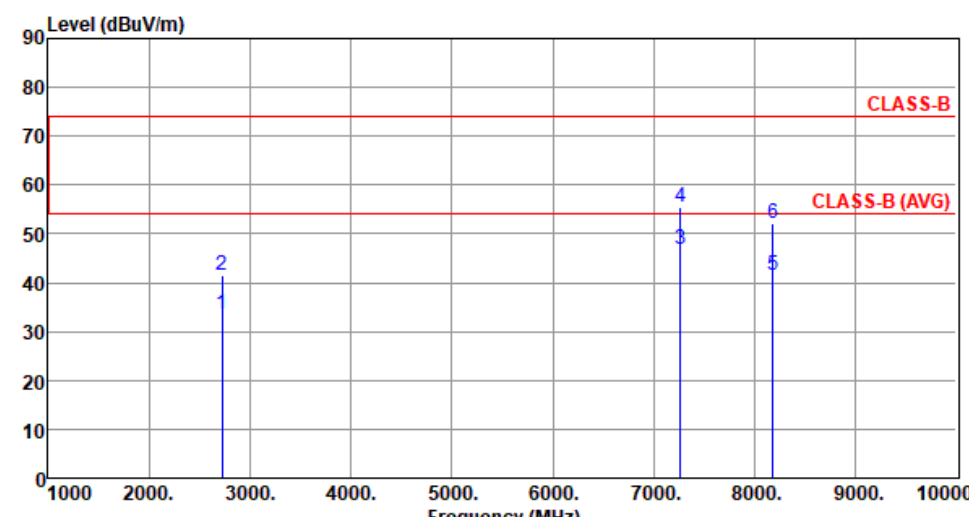
Polarization	Vertical	Test Freq. (MHz)	908.5																																																																											
Test By :Akun Chung Temperature(°C):24 Humidity(%):64																																																																														
																																																																														
	<table border="1"> <thead> <tr> <th></th> <th>Freq. MHz</th> <th>Emission level dBUV/m</th> <th>Limit dBUV/m</th> <th>Margin dB</th> <th>SA reading dBUV</th> <th>Factor dB/m</th> <th>Remark</th> <th>ANT High cm</th> <th>Turn Table deg</th> </tr> </thead> <tbody> <tr> <td>1</td> <td>2725.50</td> <td>33.61</td> <td>54.00</td> <td>-20.39</td> <td>35.66</td> <td>-2.05</td> <td>Average</td> <td>183</td> <td>346</td> </tr> <tr> <td>2</td> <td>2725.50</td> <td>41.35</td> <td>74.00</td> <td>-32.65</td> <td>43.40</td> <td>-2.05</td> <td>Peak</td> <td>183</td> <td>346</td> </tr> <tr> <td>3</td> <td>7268.00</td> <td>46.98</td> <td>54.00</td> <td>-7.02</td> <td>37.98</td> <td>9.00</td> <td>Average</td> <td>100</td> <td>183</td> </tr> <tr> <td>4</td> <td>7268.00</td> <td>55.61</td> <td>74.00</td> <td>-18.39</td> <td>46.61</td> <td>9.00</td> <td>Peak</td> <td>100</td> <td>183</td> </tr> <tr> <td>5</td> <td>8176.50</td> <td>41.36</td> <td>54.00</td> <td>-12.64</td> <td>31.86</td> <td>9.50</td> <td>Average</td> <td>100</td> <td>229</td> </tr> <tr> <td>6</td> <td>8176.50</td> <td>52.00</td> <td>74.00</td> <td>-22.00</td> <td>42.50</td> <td>9.50</td> <td>Peak</td> <td>100</td> <td>229</td> </tr> </tbody> </table>		Freq. MHz	Emission level dBUV/m	Limit dBUV/m	Margin dB	SA reading dBUV	Factor dB/m	Remark	ANT High cm	Turn Table deg	1	2725.50	33.61	54.00	-20.39	35.66	-2.05	Average	183	346	2	2725.50	41.35	74.00	-32.65	43.40	-2.05	Peak	183	346	3	7268.00	46.98	54.00	-7.02	37.98	9.00	Average	100	183	4	7268.00	55.61	74.00	-18.39	46.61	9.00	Peak	100	183	5	8176.50	41.36	54.00	-12.64	31.86	9.50	Average	100	229	6	8176.50	52.00	74.00	-22.00	42.50	9.50	Peak	100	229							
	Freq. MHz	Emission level dBUV/m	Limit dBUV/m	Margin dB	SA reading dBUV	Factor dB/m	Remark	ANT High cm	Turn Table deg																																																																					
1	2725.50	33.61	54.00	-20.39	35.66	-2.05	Average	183	346																																																																					
2	2725.50	41.35	74.00	-32.65	43.40	-2.05	Peak	183	346																																																																					
3	7268.00	46.98	54.00	-7.02	37.98	9.00	Average	100	183																																																																					
4	7268.00	55.61	74.00	-18.39	46.61	9.00	Peak	100	183																																																																					
5	8176.50	41.36	54.00	-12.64	31.86	9.50	Average	100	229																																																																					
6	8176.50	52.00	74.00	-22.00	42.50	9.50	Peak	100	229																																																																					
Note 1: Emission Level (dBUV/m) = SA Reading (dBUV/m) + Factor* (dB) *Factor includes antenna factor , cable loss and amplifier gain Note 2: Margin (dB) = Emission level (dBUV/m) – Limit (dBUV/m).																																																																														

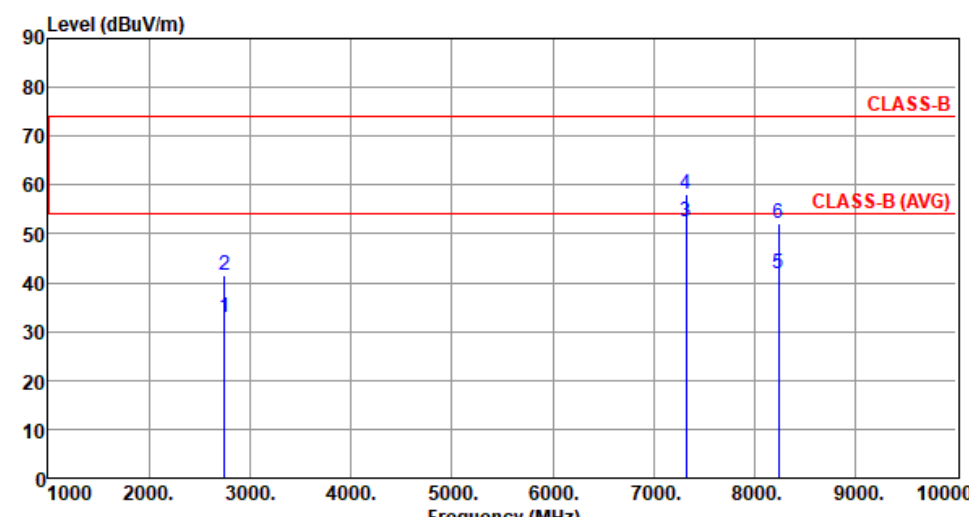
Polarization	Horizontal		Test Freq. (MHz)	914.9					
Test By	:Akun Chung		Temperature(°C):24	Humidity(%):64					
									
	Freq.	Emission level	Limit	Margin	SA reading	Factor	Remark	ANT High	Turn Table
	MHz	dBuV/m	dBuV/m	dB	dBuV	dB/m		cm	deg
1	2744.70	32.93	54.00	-21.07	34.85	-1.92	Average	333	90
2	2744.70	41.66	74.00	-32.34	43.58	-1.92	Peak	333	90
3	7319.20	52.56	54.00	-1.44	43.54	9.02	Average	370	40
4	7319.20	58.07	74.00	-15.93	49.05	9.02	Peak	370	40
5	8234.10	41.95	54.00	-12.05	32.54	9.41	Average	171	32
6	8234.10	52.06	74.00	-21.94	42.65	9.41	Peak	171	32
<p>Note 1: Emission Level (dBuV/m) = SA Reading (dBuV/m) + Factor* (dB) *Factor includes antenna factor , cable loss and amplifier gain Note 2: Margin (dB) = Emission level (dBuV/m) – Limit (dBuV/m).</p>									

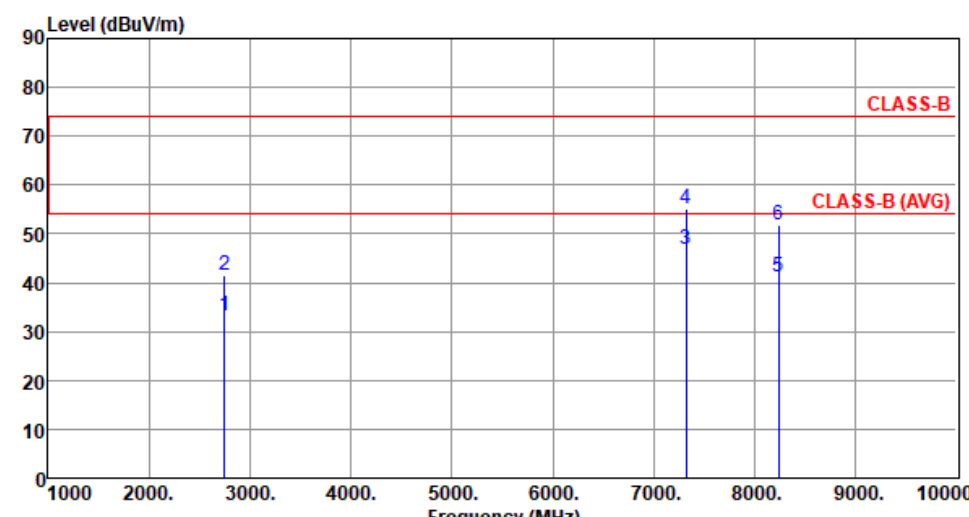
Polarization	Vertical	Test Freq. (MHz)	914.9																																																																												
Test By :Akun Chung Temperature(°C):24 Humidity(%):64																																																																															
																																																																															
	<table border="1"> <thead> <tr> <th></th> <th>Freq. MHz</th> <th>Emission level dBUV/m</th> <th>Limit dBUV/m</th> <th>Margin dB</th> <th>SA reading dBUV</th> <th>Factor dB/m</th> <th>Remark</th> <th>ANT High cm</th> <th>Turn Table deg</th> </tr> </thead> <tbody> <tr> <td>1</td> <td>2744.70</td> <td>33.29</td> <td>54.00</td> <td>-20.71</td> <td>35.21</td> <td>-1.92</td> <td>Average</td> <td>192</td> <td>352</td> </tr> <tr> <td>2</td> <td>2744.70</td> <td>41.40</td> <td>74.00</td> <td>-32.60</td> <td>43.32</td> <td>-1.92</td> <td>Peak</td> <td>192</td> <td>352</td> </tr> <tr> <td>3</td> <td>7319.20</td> <td>46.89</td> <td>54.00</td> <td>-7.11</td> <td>37.87</td> <td>9.02</td> <td>Average</td> <td>100</td> <td>185</td> </tr> <tr> <td>4</td> <td>7319.20</td> <td>55.00</td> <td>74.00</td> <td>-19.00</td> <td>45.98</td> <td>9.02</td> <td>Peak</td> <td>100</td> <td>185</td> </tr> <tr> <td>5</td> <td>8234.10</td> <td>41.07</td> <td>54.00</td> <td>-12.93</td> <td>31.66</td> <td>9.41</td> <td>Average</td> <td>100</td> <td>232</td> </tr> <tr> <td>6</td> <td>8234.10</td> <td>51.82</td> <td>74.00</td> <td>-22.18</td> <td>42.41</td> <td>9.41</td> <td>Peak</td> <td>100</td> <td>232</td> </tr> </tbody> </table>		Freq. MHz	Emission level dBUV/m	Limit dBUV/m	Margin dB	SA reading dBUV	Factor dB/m	Remark	ANT High cm	Turn Table deg	1	2744.70	33.29	54.00	-20.71	35.21	-1.92	Average	192	352	2	2744.70	41.40	74.00	-32.60	43.32	-1.92	Peak	192	352	3	7319.20	46.89	54.00	-7.11	37.87	9.02	Average	100	185	4	7319.20	55.00	74.00	-19.00	45.98	9.02	Peak	100	185	5	8234.10	41.07	54.00	-12.93	31.66	9.41	Average	100	232	6	8234.10	51.82	74.00	-22.18	42.41	9.41	Peak	100	232								
	Freq. MHz	Emission level dBUV/m	Limit dBUV/m	Margin dB	SA reading dBUV	Factor dB/m	Remark	ANT High cm	Turn Table deg																																																																						
1	2744.70	33.29	54.00	-20.71	35.21	-1.92	Average	192	352																																																																						
2	2744.70	41.40	74.00	-32.60	43.32	-1.92	Peak	192	352																																																																						
3	7319.20	46.89	54.00	-7.11	37.87	9.02	Average	100	185																																																																						
4	7319.20	55.00	74.00	-19.00	45.98	9.02	Peak	100	185																																																																						
5	8234.10	41.07	54.00	-12.93	31.66	9.41	Average	100	232																																																																						
6	8234.10	51.82	74.00	-22.18	42.41	9.41	Peak	100	232																																																																						
<p>Note 1: Emission Level (dBUV/m) = SA Reading (dBUV/m) + Factor* (dB) *Factor includes antenna factor , cable loss and amplifier gain Note 2: Margin (dB) = Emission level (dBUV/m) – Limit (dBUV/m).</p>																																																																															

Channel Bandwidth 500kHz

3.2.6 Transmitter Radiated Unwanted Emissions (Below 1GHz)

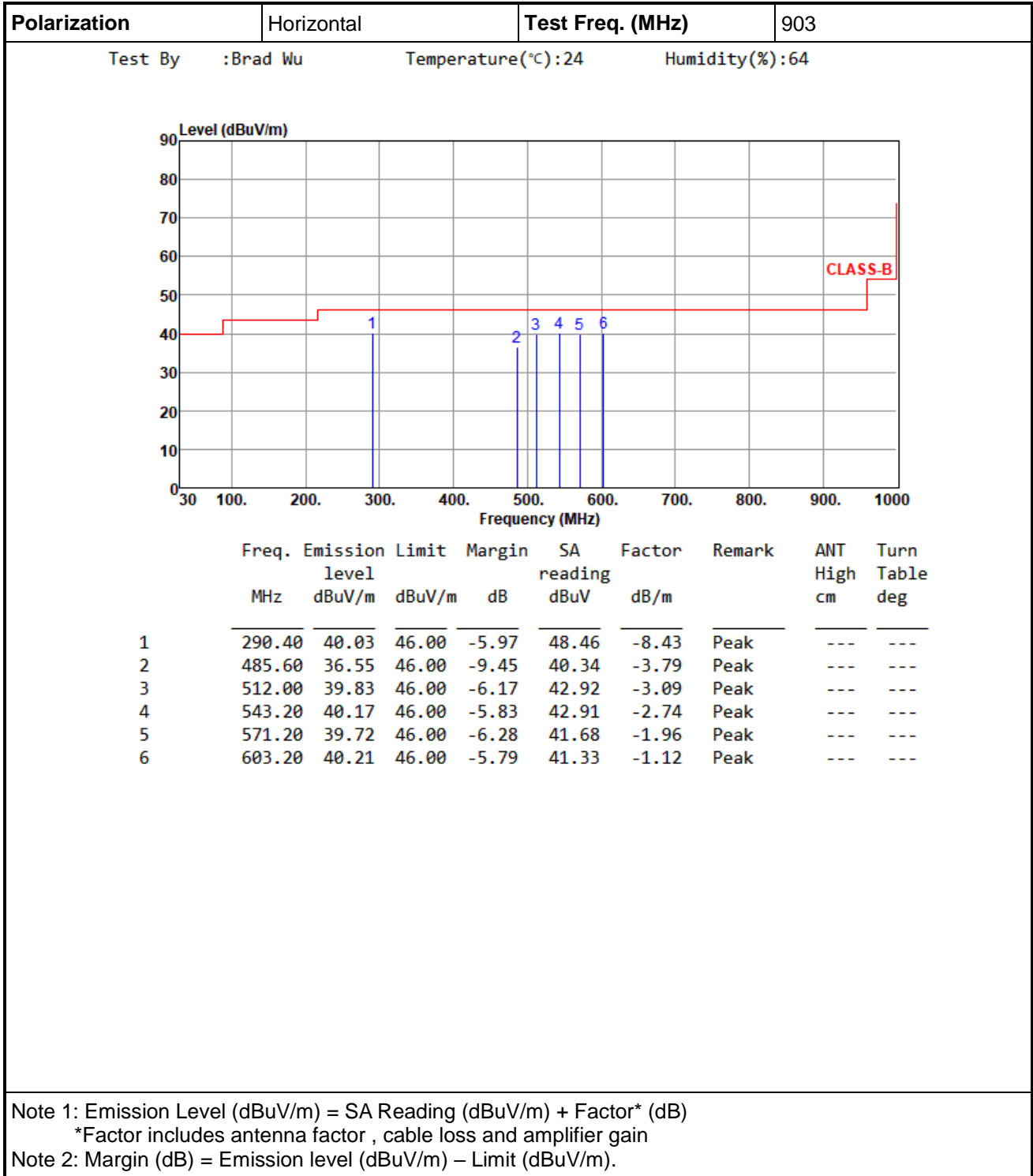

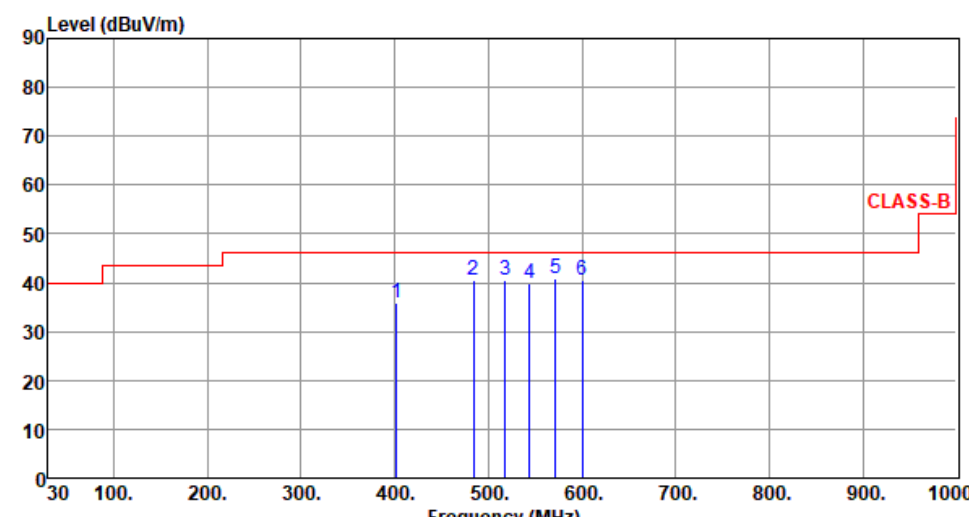
Polarization	Vertical	Test Freq. (MHz)	903						
Test By	:Brad Wu	Temperature(°C):24	Humidity(%):64						
									
	Freq.	Emission level	Limit	Margin	SA reading	Factor	Remark	ANT High	Turn Table
	MHz	dBuV/m	dBuV/m	dB	dBuV	dB/m		cm	deg
1	401.60	36.00	46.00	-10.00	41.83	-5.83	Peak	---	---
2	484.00	40.67	46.00	-5.33	44.48	-3.81	Peak	---	---
3	517.60	40.55	46.00	-5.45	43.56	-3.01	Peak	---	---
4	544.00	39.84	46.00	-6.16	42.58	-2.74	Peak	---	---
5	572.00	40.77	46.00	-5.23	42.71	-1.94	Peak	---	---
6	600.00	40.60	46.00	-5.40	41.73	-1.13	Peak	---	---
<p>Note 1: Emission Level (dBuV/m) = SA Reading (dBuV/m) + Factor* (dB) *Factor includes antenna factor , cable loss and amplifier gain Note 2: Margin (dB) = Emission level (dBuV/m) – Limit (dBuV/m).</p>									

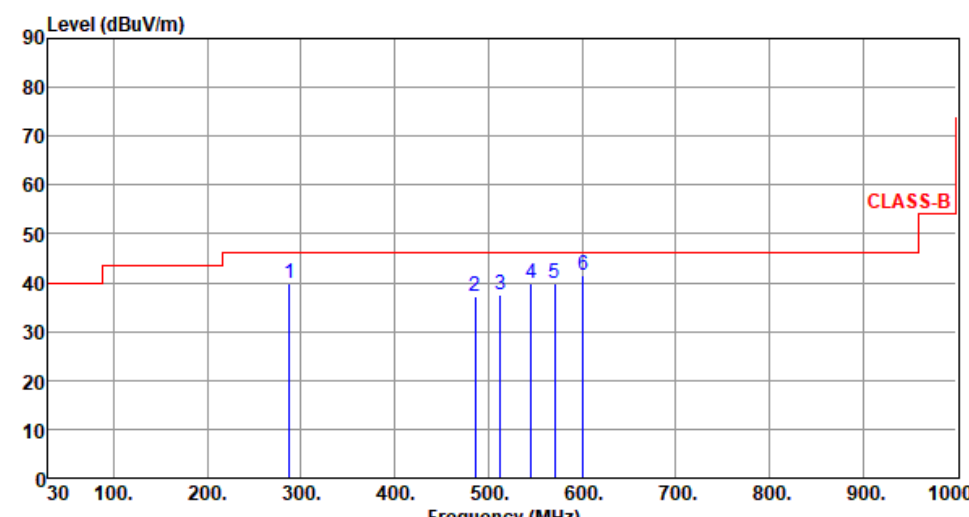
Polarization	Horizontal		Test Freq. (MHz)	907.8					
Test By	:Brad Wu		Temperature(°C):24	Humidity(%):64					
									
	Freq.	Emission level	Limit	Margin	SA reading	Factor	Remark	ANT High	Turn Table
	MHz	dBuV/m	dBuV/m	dB	dBuV	dB/m		cm	deg
1	288.00	39.81	46.00	-6.19	48.34	-8.53	Peak	---	---
2	486.40	37.27	46.00	-8.73	41.04	-3.77	Peak	---	---
3	512.80	37.69	46.00	-8.31	40.75	-3.06	Peak	---	---
4	545.60	39.91	46.00	-6.09	42.63	-2.72	Peak	---	---
5	571.20	39.70	46.00	-6.30	41.66	-1.96	Peak	---	---
6	600.80	41.47	46.00	-4.53	42.60	-1.13	Peak	---	---
<p>Note 1: Emission Level (dBUV/m) = SA Reading (dBUV/m) + Factor* (dB) *Factor includes antenna factor , cable loss and amplifier gain Note 2: Margin (dB) = Emission level (dBUV/m) – Limit (dBUV/m).</p>									

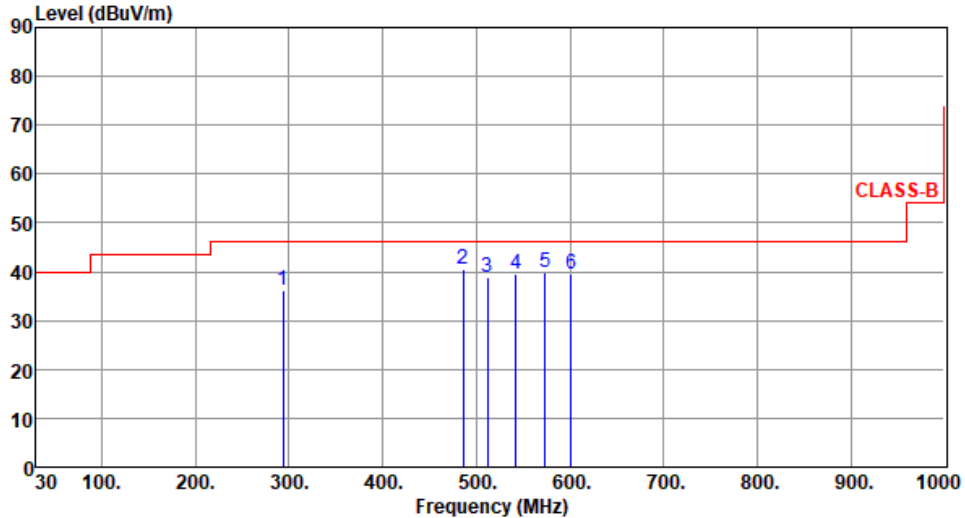
Polarization	Vertical	Test Freq. (MHz)	907.8						
Test By	:Brad Wu	Temperature(°C):24	Humidity(%):64						
									
	Freq. MHz	Emission level dBuV/m	Limit dBuV/m	Margin dB	SA reading dBuV	Factor dB/m	Remark	ANT High cm	Turn Table deg
1	293.60	36.12	46.00	-9.88	44.48	-8.36	Peak	---	---
2	486.40	40.40	46.00	-5.60	44.17	-3.77	Peak	---	---
3	512.00	39.01	46.00	-6.99	42.10	-3.09	Peak	---	---
4	542.40	39.47	46.00	-6.53	42.22	-2.75	Peak	---	---
5	573.60	39.92	46.00	-6.08	41.83	-1.91	Peak	---	---
6	600.80	39.48	46.00	-6.52	40.61	-1.13	Peak	---	---
<p>Note 1: Emission Level (dBuV/m) = SA Reading (dBuV/m) + Factor* (dB) *Factor includes antenna factor , cable loss and amplifier gain Note 2: Margin (dB) = Emission level (dBuV/m) – Limit (dBuV/m).</p>									

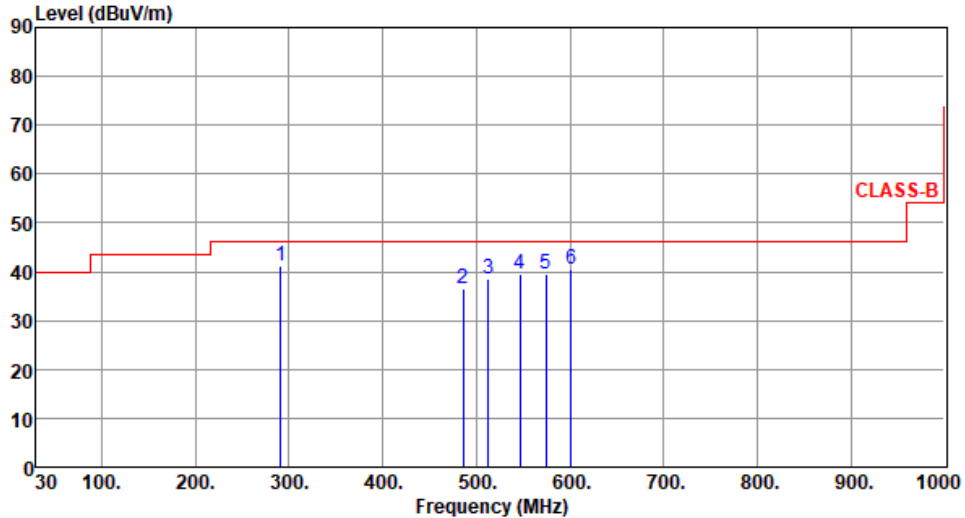
Polarization	Horizontal		Test Freq. (MHz)	914.2					
Test By	:Brad Wu		Temperature(°C):24	Humidity(%):64					
									
	Freq. MHz	Emission level dBuV/m	Limit dBuV/m	Margin dB	SA reading dBuV	Factor dB/m	Remark	ANT High cm	Turn Table deg
1	291.20	41.10	46.00	-4.90	49.52	-8.42	Peak	---	---
2	485.60	36.60	46.00	-9.40	40.39	-3.79	Peak	---	---
3	512.80	38.61	46.00	-7.39	41.67	-3.06	Peak	---	---
4	546.40	39.41	46.00	-6.59	42.09	-2.68	Peak	---	---
5	574.40	39.43	46.00	-6.57	41.32	-1.89	Peak	---	---
6	600.80	40.39	46.00	-5.61	41.52	-1.13	Peak	---	---
<p>Note 1: Emission Level (dBuV/m) = SA Reading (dBuV/m) + Factor* (dB) *Factor includes antenna factor , cable loss and amplifier gain Note 2: Margin (dB) = Emission level (dBuV/m) – Limit (dBuV/m).</p>									

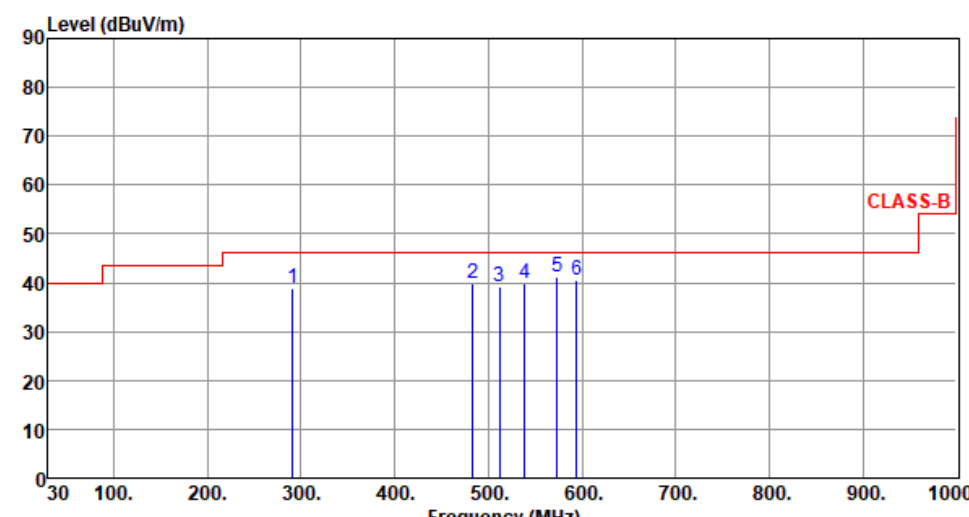
Polarization	Vertical	Test Freq. (MHz)	914.2																																																																													
Test By	:Brad Wu	Temperature(°C):24	Humidity(%) :64																																																																													
																																																																																
	<table border="1"> <thead> <tr> <th>Freq.</th> <th>Emission level</th> <th>Limit</th> <th>Margin</th> <th>SA reading</th> <th>Factor</th> <th>Remark</th> <th>ANT High</th> <th>Turn Table</th> </tr> <tr> <th>MHz</th> <th>dBuV/m</th> <th>dBuV/m</th> <th>dB</th> <th>dBuV</th> <th>dB/m</th> <th></th> <th>cm</th> <th>deg</th> </tr> </thead> <tbody> <tr> <td>1</td> <td>291.20</td> <td>38.74</td> <td>46.00</td> <td>-7.26</td> <td>47.16</td> <td>-8.42</td> <td>Peak</td> <td>---</td> </tr> <tr> <td>2</td> <td>483.20</td> <td>39.74</td> <td>46.00</td> <td>-6.26</td> <td>43.55</td> <td>-3.81</td> <td>Peak</td> <td>---</td> </tr> <tr> <td>3</td> <td>512.00</td> <td>39.08</td> <td>46.00</td> <td>-6.92</td> <td>42.17</td> <td>-3.09</td> <td>Peak</td> <td>---</td> </tr> <tr> <td>4</td> <td>538.40</td> <td>39.94</td> <td>46.00</td> <td>-6.06</td> <td>42.75</td> <td>-2.81</td> <td>Peak</td> <td>---</td> </tr> <tr> <td>5</td> <td>573.60</td> <td>41.19</td> <td>46.00</td> <td>-4.81</td> <td>43.10</td> <td>-1.91</td> <td>Peak</td> <td>---</td> </tr> <tr> <td>6</td> <td>594.40</td> <td>40.61</td> <td>46.00</td> <td>-5.39</td> <td>42.05</td> <td>-1.44</td> <td>Peak</td> <td>---</td> </tr> </tbody> </table>	Freq.	Emission level	Limit	Margin	SA reading	Factor	Remark	ANT High	Turn Table	MHz	dBuV/m	dBuV/m	dB	dBuV	dB/m		cm	deg	1	291.20	38.74	46.00	-7.26	47.16	-8.42	Peak	---	2	483.20	39.74	46.00	-6.26	43.55	-3.81	Peak	---	3	512.00	39.08	46.00	-6.92	42.17	-3.09	Peak	---	4	538.40	39.94	46.00	-6.06	42.75	-2.81	Peak	---	5	573.60	41.19	46.00	-4.81	43.10	-1.91	Peak	---	6	594.40	40.61	46.00	-5.39	42.05	-1.44	Peak	---							
Freq.	Emission level	Limit	Margin	SA reading	Factor	Remark	ANT High	Turn Table																																																																								
MHz	dBuV/m	dBuV/m	dB	dBuV	dB/m		cm	deg																																																																								
1	291.20	38.74	46.00	-7.26	47.16	-8.42	Peak	---																																																																								
2	483.20	39.74	46.00	-6.26	43.55	-3.81	Peak	---																																																																								
3	512.00	39.08	46.00	-6.92	42.17	-3.09	Peak	---																																																																								
4	538.40	39.94	46.00	-6.06	42.75	-2.81	Peak	---																																																																								
5	573.60	41.19	46.00	-4.81	43.10	-1.91	Peak	---																																																																								
6	594.40	40.61	46.00	-5.39	42.05	-1.44	Peak	---																																																																								
<p>Note 1: Emission Level (dBuV/m) = SA Reading (dBuV/m) + Factor* (dB) *Factor includes antenna factor , cable loss and amplifier gain Note 2: Margin (dB) = Emission level (dBuV/m) – Limit (dBuV/m).</p>																																																																																

3.2.7 Transmitter Radiated Unwanted Emissions (Above 1GHz)

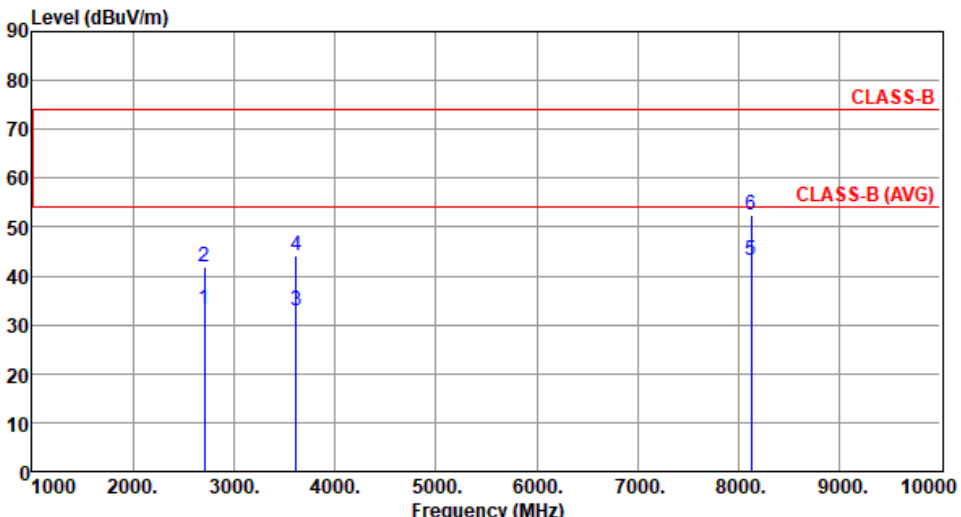
Polarization	Horizontal		Test Freq. (MHz)	903					
Test By	:Akun Chung		Temperature(°C):24	Humidity(%):64					
									
	Freq.	Emission level	Limit	Margin	SA	Factor	Remark	ANT	Turn
	MHz	dBuV/m	dBuV/m	dB	reading	dB/m		High	Table
								cm	deg
1	2709.00	33.37	54.00	-20.63	35.54	-2.17	Average	366	82
2	2709.00	41.94	74.00	-32.06	44.11	-2.17	Peak	366	82
3	3612.00	33.02	54.00	-20.98	32.81	0.21	Average	158	53
4	3612.00	44.32	74.00	-29.68	44.11	0.21	Peak	158	53
5	8127.00	43.20	54.00	-10.80	33.55	9.65	Average	136	31
6	8127.00	52.60	74.00	-21.40	42.95	9.65	Peak	136	31

Note 1: Emission Level (dBuV/m) = SA Reading (dBuV/m) + Factor* (dB)
 *Factor includes antenna factor , cable loss and amplifier gain
 Note 2: Margin (dB) = Emission level (dBuV/m) – Limit (dBuV/m).

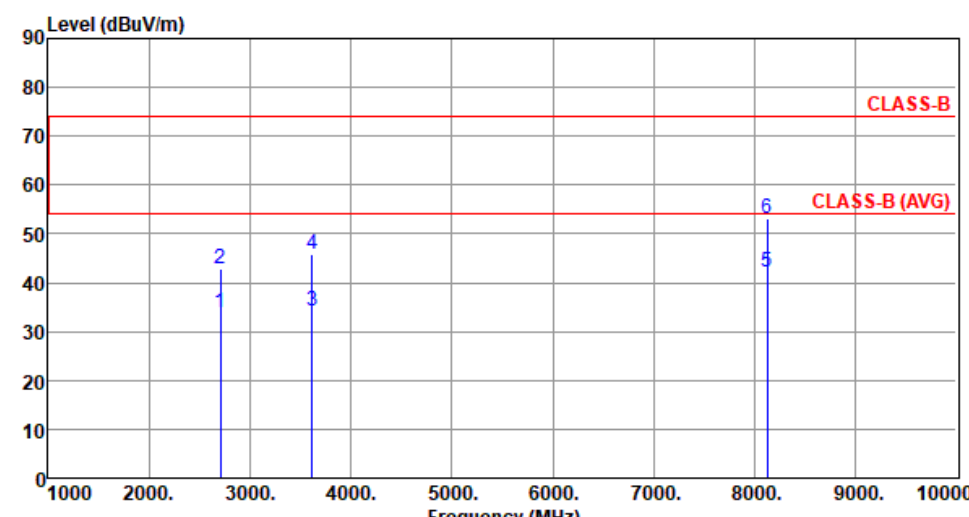
Polarization	Vertical	Test Freq. (MHz)	903																																																																								
Test By	:Akun Chung	Temperature(°C):24	Humidity(%) :64																																																																								
																																																																											
	<table border="1"> <thead> <tr> <th></th> <th>Freq. MHz</th> <th>Emission level dBuV/m</th> <th>Limit dBuV/m</th> <th>Margin dB</th> <th>SA reading dBuV</th> <th>Factor dB/m</th> <th>Remark</th> <th>ANT High cm</th> <th>Turn Table deg</th> </tr> </thead> <tbody> <tr> <td>1</td> <td>2709.00</td> <td>33.78</td> <td>54.00</td> <td>-20.22</td> <td>35.95</td> <td>-2.17</td> <td>Average</td> <td>202</td> <td>342</td> </tr> <tr> <td>2</td> <td>2709.00</td> <td>42.68</td> <td>74.00</td> <td>-31.32</td> <td>44.85</td> <td>-2.17</td> <td>Peak</td> <td>202</td> <td>342</td> </tr> <tr> <td>3</td> <td>3612.00</td> <td>34.18</td> <td>54.00</td> <td>-19.82</td> <td>33.97</td> <td>0.21</td> <td>Average</td> <td>100</td> <td>187</td> </tr> <tr> <td>4</td> <td>3612.00</td> <td>45.96</td> <td>74.00</td> <td>-28.04</td> <td>45.75</td> <td>0.21</td> <td>Peak</td> <td>100</td> <td>187</td> </tr> <tr> <td>5</td> <td>8127.00</td> <td>42.23</td> <td>54.00</td> <td>-11.77</td> <td>32.58</td> <td>9.65</td> <td>Average</td> <td>100</td> <td>246</td> </tr> <tr> <td>6</td> <td>8127.00</td> <td>53.19</td> <td>74.00</td> <td>-20.81</td> <td>43.54</td> <td>9.65</td> <td>Peak</td> <td>100</td> <td>246</td> </tr> </tbody> </table>		Freq. MHz	Emission level dBuV/m	Limit dBuV/m	Margin dB	SA reading dBuV	Factor dB/m	Remark	ANT High cm	Turn Table deg	1	2709.00	33.78	54.00	-20.22	35.95	-2.17	Average	202	342	2	2709.00	42.68	74.00	-31.32	44.85	-2.17	Peak	202	342	3	3612.00	34.18	54.00	-19.82	33.97	0.21	Average	100	187	4	3612.00	45.96	74.00	-28.04	45.75	0.21	Peak	100	187	5	8127.00	42.23	54.00	-11.77	32.58	9.65	Average	100	246	6	8127.00	53.19	74.00	-20.81	43.54	9.65	Peak	100	246				
	Freq. MHz	Emission level dBuV/m	Limit dBuV/m	Margin dB	SA reading dBuV	Factor dB/m	Remark	ANT High cm	Turn Table deg																																																																		
1	2709.00	33.78	54.00	-20.22	35.95	-2.17	Average	202	342																																																																		
2	2709.00	42.68	74.00	-31.32	44.85	-2.17	Peak	202	342																																																																		
3	3612.00	34.18	54.00	-19.82	33.97	0.21	Average	100	187																																																																		
4	3612.00	45.96	74.00	-28.04	45.75	0.21	Peak	100	187																																																																		
5	8127.00	42.23	54.00	-11.77	32.58	9.65	Average	100	246																																																																		
6	8127.00	53.19	74.00	-20.81	43.54	9.65	Peak	100	246																																																																		
<p>Note 1: Emission Level (dBuV/m) = SA Reading (dBuV/m) + Factor* (dB) *Factor includes antenna factor , cable loss and amplifier gain Note 2: Margin (dB) = Emission level (dBuV/m) – Limit (dBuV/m).</p>																																																																											

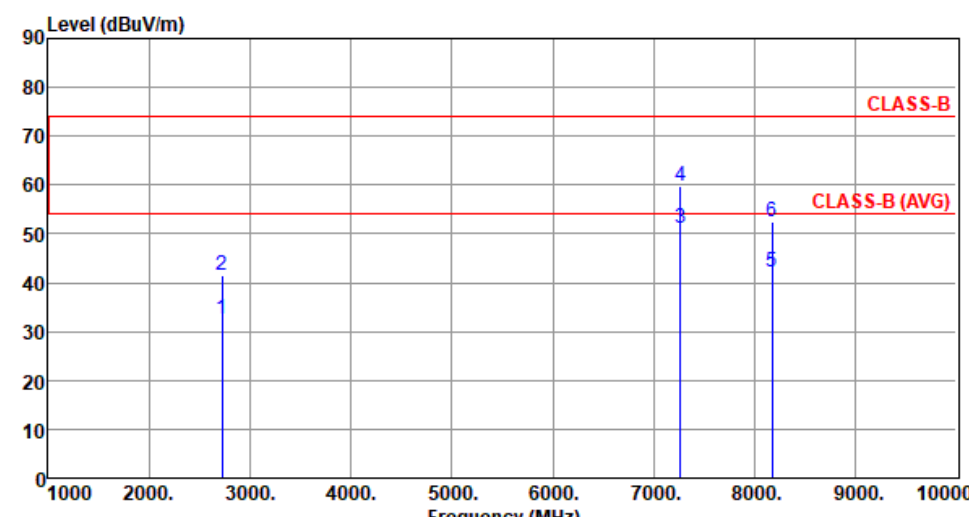
Polarization	Horizontal		Test Freq. (MHz)	907.8					
Test By	:Akun Chung		Temperature(°C)	:24					
			Humidity(%)	:64					
									
	Freq.	Emission level	Limit	Margin	SA reading	Factor	Remark	ANT High	Turn Table
	MHz	dBuV/m	dBuV/m	dB	dBuV	dB/m		cm	deg
1	2723.40	32.50	54.00	-21.50	34.57	-2.07	Average	375	78
2	2723.40	41.49	74.00	-32.51	43.56	-2.07	Peak	375	78
3	7262.40	51.11	54.00	-2.89	42.12	8.99	Average	372	42
4	7262.40	59.85	74.00	-14.15	50.86	8.99	Peak	372	42
5	8170.20	42.17	54.00	-11.83	32.66	9.51	Average	170	34
6	8170.20	52.48	74.00	-21.52	42.97	9.51	Peak	170	34
<p>Note 1: Emission Level (dBuV/m) = SA Reading (dBuV/m) + Factor* (dB) *Factor includes antenna factor , cable loss and amplifier gain Note 2: Margin (dB) = Emission level (dBuV/m) – Limit (dBuV/m).</p>									

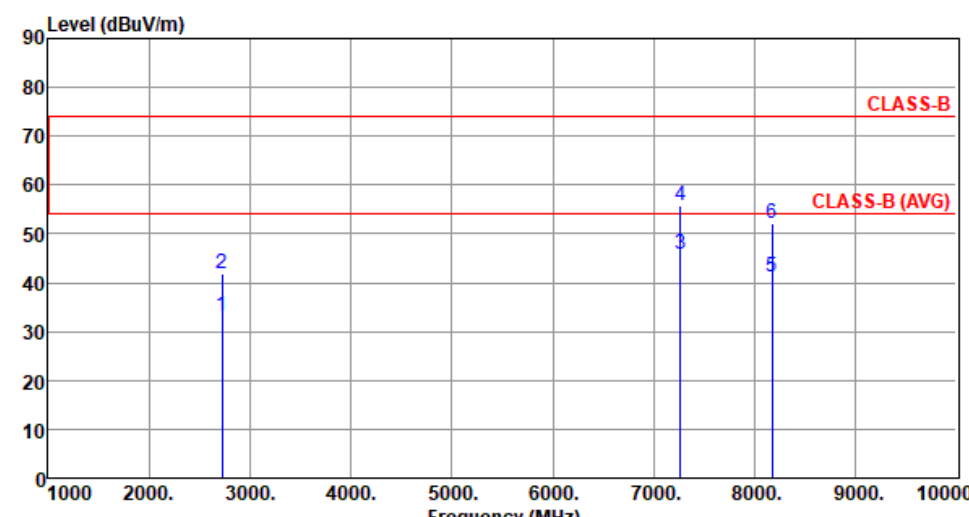
Polarization	Vertical	Test Freq. (MHz)	907.8																																																																												
Test By	:Akun Chung	Temperature(°C):24	Humidity(%) :64																																																																												
																																																																															
	<table border="1"> <thead> <tr> <th></th> <th>Freq. MHz</th> <th>Emission level dBUV/m</th> <th>Limit dBUV/m</th> <th>Margin dB</th> <th>SA reading dBUV</th> <th>Factor dB/m</th> <th>Remark</th> <th>ANT High cm</th> <th>Turn Table deg</th> </tr> </thead> <tbody> <tr> <td>1</td> <td>2723.40</td> <td>33.07</td> <td>54.00</td> <td>-20.93</td> <td>35.14</td> <td>-2.07</td> <td>Average</td> <td>188</td> <td>351</td> </tr> <tr> <td>2</td> <td>2723.40</td> <td>41.88</td> <td>74.00</td> <td>-32.12</td> <td>43.95</td> <td>-2.07</td> <td>Peak</td> <td>188</td> <td>351</td> </tr> <tr> <td>3</td> <td>7262.40</td> <td>45.88</td> <td>54.00</td> <td>-8.12</td> <td>36.89</td> <td>8.99</td> <td>Average</td> <td>100</td> <td>180</td> </tr> <tr> <td>4</td> <td>7262.40</td> <td>55.88</td> <td>74.00</td> <td>-18.12</td> <td>46.89</td> <td>8.99</td> <td>Peak</td> <td>100</td> <td>180</td> </tr> <tr> <td>5</td> <td>8170.20</td> <td>41.26</td> <td>54.00</td> <td>-12.74</td> <td>31.75</td> <td>9.51</td> <td>Average</td> <td>100</td> <td>233</td> </tr> <tr> <td>6</td> <td>8170.20</td> <td>52.18</td> <td>74.00</td> <td>-21.82</td> <td>42.67</td> <td>9.51</td> <td>Peak</td> <td>100</td> <td>233</td> </tr> </tbody> </table>		Freq. MHz	Emission level dBUV/m	Limit dBUV/m	Margin dB	SA reading dBUV	Factor dB/m	Remark	ANT High cm	Turn Table deg	1	2723.40	33.07	54.00	-20.93	35.14	-2.07	Average	188	351	2	2723.40	41.88	74.00	-32.12	43.95	-2.07	Peak	188	351	3	7262.40	45.88	54.00	-8.12	36.89	8.99	Average	100	180	4	7262.40	55.88	74.00	-18.12	46.89	8.99	Peak	100	180	5	8170.20	41.26	54.00	-12.74	31.75	9.51	Average	100	233	6	8170.20	52.18	74.00	-21.82	42.67	9.51	Peak	100	233								
	Freq. MHz	Emission level dBUV/m	Limit dBUV/m	Margin dB	SA reading dBUV	Factor dB/m	Remark	ANT High cm	Turn Table deg																																																																						
1	2723.40	33.07	54.00	-20.93	35.14	-2.07	Average	188	351																																																																						
2	2723.40	41.88	74.00	-32.12	43.95	-2.07	Peak	188	351																																																																						
3	7262.40	45.88	54.00	-8.12	36.89	8.99	Average	100	180																																																																						
4	7262.40	55.88	74.00	-18.12	46.89	8.99	Peak	100	180																																																																						
5	8170.20	41.26	54.00	-12.74	31.75	9.51	Average	100	233																																																																						
6	8170.20	52.18	74.00	-21.82	42.67	9.51	Peak	100	233																																																																						
<p>Note 1: Emission Level (dBUV/m) = SA Reading (dBUV/m) + Factor* (dB) *Factor includes antenna factor , cable loss and amplifier gain Note 2: Margin (dB) = Emission level (dBUV/m) – Limit (dBUV/m).</p>																																																																															

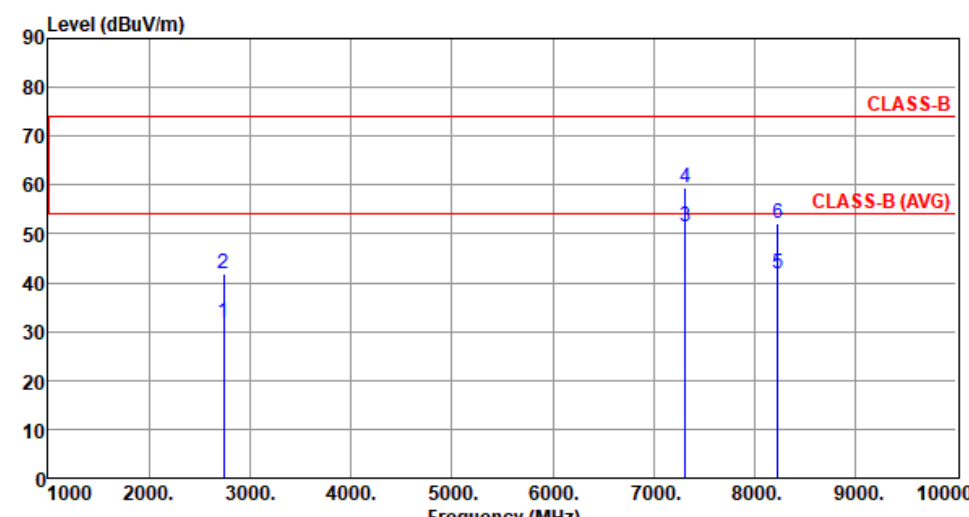
Polarization	Horizontal		Test Freq. (MHz)	914.2					
Test By	:Akun Chung		Temperature(°C)	:24					
			Humidity(%)	:64					
									
	Freq.	Emission level	Limit	Margin	SA reading	Factor	Remark	ANT High	Turn Table
	MHz	dBuV/m	dBuV/m	dB	dBuV	dB/m		cm	deg
1	2742.60	31.83	54.00	-22.17	33.76	-1.93	Average	324	93
2	2742.60	41.72	74.00	-32.28	43.65	-1.93	Peak	324	93
3	7313.60	51.42	54.00	-2.58	42.41	9.01	Average	368	38
4	7313.60	59.55	74.00	-14.45	50.54	9.01	Peak	368	38
5	8227.80	41.86	54.00	-12.14	32.44	9.42	Average	180	33
6	8227.80	52.22	74.00	-21.78	42.80	9.42	Peak	180	33
<p>Note 1: Emission Level (dBuV/m) = SA Reading (dBuV/m) + Factor* (dB) *Factor includes antenna factor , cable loss and amplifier gain Note 2: Margin (dB) = Emission level (dBuV/m) – Limit (dBuV/m).</p>									

Polarization	Vertical	Test Freq. (MHz)	914.2																																																																												
Test By :Akun Chung Temperature(°C):24 Humidity(%):64																																																																															
	<table border="1"> <thead> <tr> <th></th> <th>Freq. MHz</th> <th>Emission level dBuV/m</th> <th>Limit dBuV/m</th> <th>Margin dB</th> <th>SA reading dBuV</th> <th>Factor dB/m</th> <th>Remark</th> <th>ANT High cm</th> <th>Turn Table deg</th> </tr> </thead> <tbody> <tr> <td>1</td> <td>2742.60</td> <td>33.04</td> <td>54.00</td> <td>-20.96</td> <td>34.97</td> <td>-1.93</td> <td>Average</td> <td>199</td> <td>357</td> </tr> <tr> <td>2</td> <td>2742.60</td> <td>41.91</td> <td>74.00</td> <td>-32.09</td> <td>43.84</td> <td>-1.93</td> <td>Peak</td> <td>199</td> <td>357</td> </tr> <tr> <td>3</td> <td>7313.60</td> <td>45.45</td> <td>54.00</td> <td>-8.55</td> <td>36.44</td> <td>9.01</td> <td>Average</td> <td>100</td> <td>192</td> </tr> <tr> <td>4</td> <td>7313.60</td> <td>55.26</td> <td>74.00</td> <td>-18.74</td> <td>46.25</td> <td>9.01</td> <td>Peak</td> <td>100</td> <td>192</td> </tr> <tr> <td>5</td> <td>8227.80</td> <td>40.87</td> <td>54.00</td> <td>-13.13</td> <td>31.45</td> <td>9.42</td> <td>Average</td> <td>100</td> <td>239</td> </tr> <tr> <td>6</td> <td>8227.80</td> <td>51.79</td> <td>74.00</td> <td>-22.21</td> <td>42.37</td> <td>9.42</td> <td>Peak</td> <td>100</td> <td>239</td> </tr> </tbody> </table>		Freq. MHz	Emission level dBuV/m	Limit dBuV/m	Margin dB	SA reading dBuV	Factor dB/m	Remark	ANT High cm	Turn Table deg	1	2742.60	33.04	54.00	-20.96	34.97	-1.93	Average	199	357	2	2742.60	41.91	74.00	-32.09	43.84	-1.93	Peak	199	357	3	7313.60	45.45	54.00	-8.55	36.44	9.01	Average	100	192	4	7313.60	55.26	74.00	-18.74	46.25	9.01	Peak	100	192	5	8227.80	40.87	54.00	-13.13	31.45	9.42	Average	100	239	6	8227.80	51.79	74.00	-22.21	42.37	9.42	Peak	100	239								
	Freq. MHz	Emission level dBuV/m	Limit dBuV/m	Margin dB	SA reading dBuV	Factor dB/m	Remark	ANT High cm	Turn Table deg																																																																						
1	2742.60	33.04	54.00	-20.96	34.97	-1.93	Average	199	357																																																																						
2	2742.60	41.91	74.00	-32.09	43.84	-1.93	Peak	199	357																																																																						
3	7313.60	45.45	54.00	-8.55	36.44	9.01	Average	100	192																																																																						
4	7313.60	55.26	74.00	-18.74	46.25	9.01	Peak	100	192																																																																						
5	8227.80	40.87	54.00	-13.13	31.45	9.42	Average	100	239																																																																						
6	8227.80	51.79	74.00	-22.21	42.37	9.42	Peak	100	239																																																																						
<p>Note 1: Emission Level (dBuV/m) = SA Reading (dBuV/m) + Factor* (dB) *Factor includes antenna factor , cable loss and amplifier gain Note 2: Margin (dB) = Emission level (dBuV/m) – Limit (dBuV/m).</p>																																																																															

3.3 Unwanted Emissions into Non-Restricted Frequency Bands

3.3.1 Limit of Unwanted Emissions into Non-Restricted Frequency Bands

The peak output power measured in any 100 kHz bandwidth outside of the authorized frequency band shall be attenuated by at least 30 dB relative to the maximum in-band peak PSD level in 100 kHz.

3.3.2 Test Procedures

Reference Level Measurement

1. Set the RBW = 100 kHz, VBW = 300 kHz, Detector = peak.
2. Set Sweep time = auto couple, Trace mode = max hold.
3. Allow trace to fully stabilize.
4. Use the peak marker function to determine the maximum amplitude level.

Unwanted Emissions Level Measurement

1. Set RBW = 100 kHz, VBW = 300 kHz, Detector = peak.
2. Trace Mode = max hold, Sweep = auto couple.
3. Allow the trace to stabilize.
4. Use peak marker function to determine maximum amplitude of all unwanted emissions within any 100 kHz bandwidth.

3.3.3 Test Setup

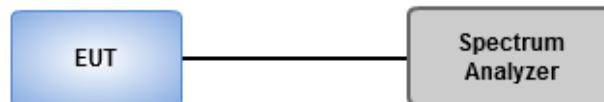

3.3.4 Unwanted Emissions into Non-Restricted Frequency Bands

Ambient Condition	24-25°C / 65-66%	Tested By	Aska Huang
-------------------	------------------	-----------	------------

Channel Bandwidth 125kHz

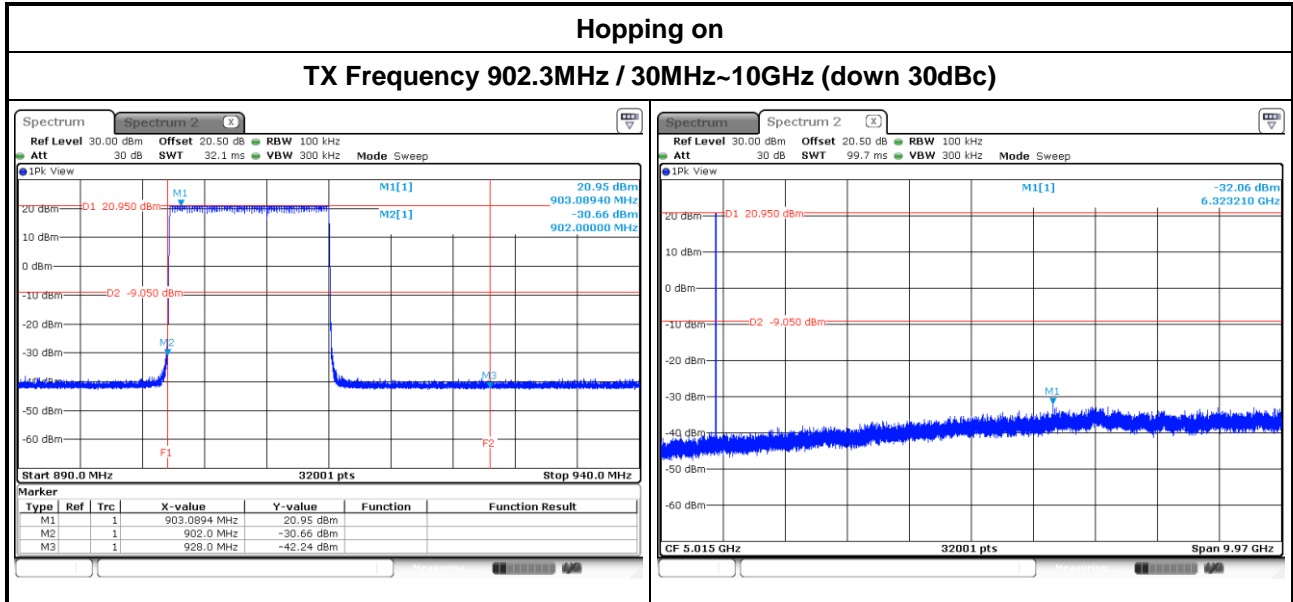

Hopping off

TX Frequency 902.3MHz / 30MHz~10GHz (down 30dBc)

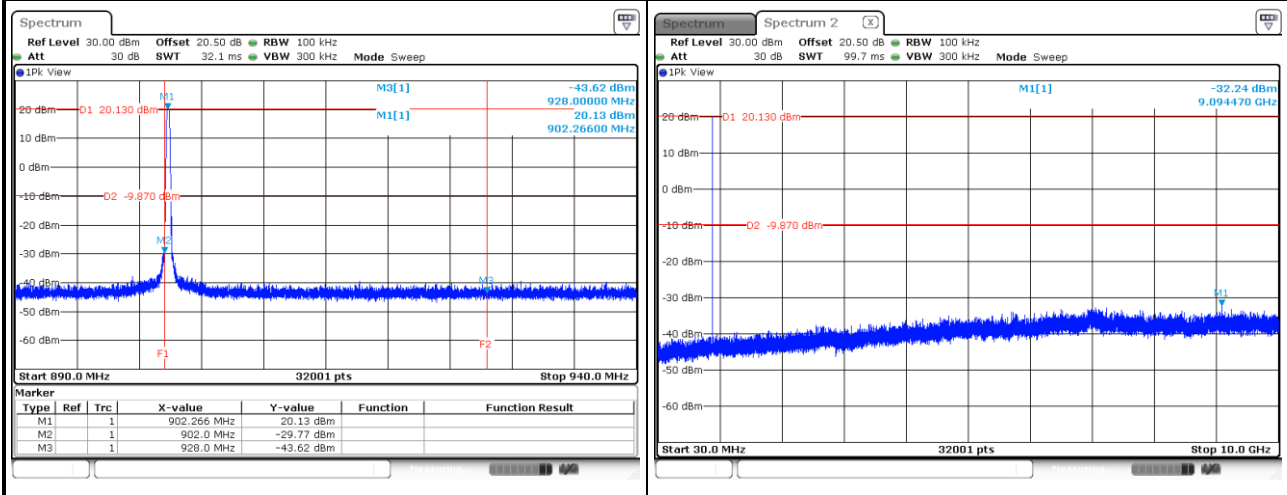

TX Frequency 908.5MHz / 30MHz~10GHz (down 30dBc)

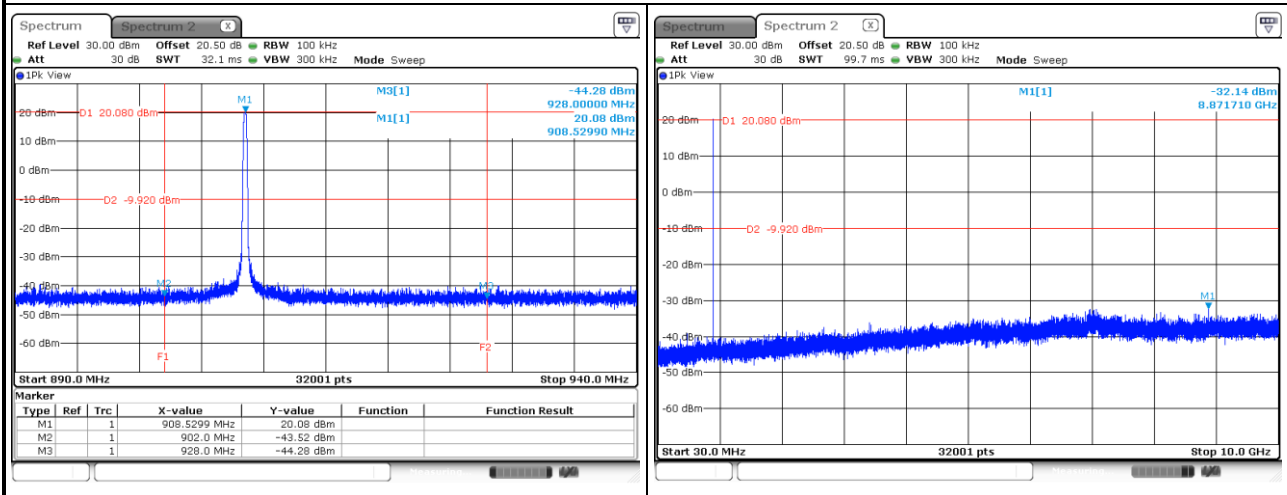

TX Frequency 914.9MHz / 30MHz~10GHz (down 30dBc)

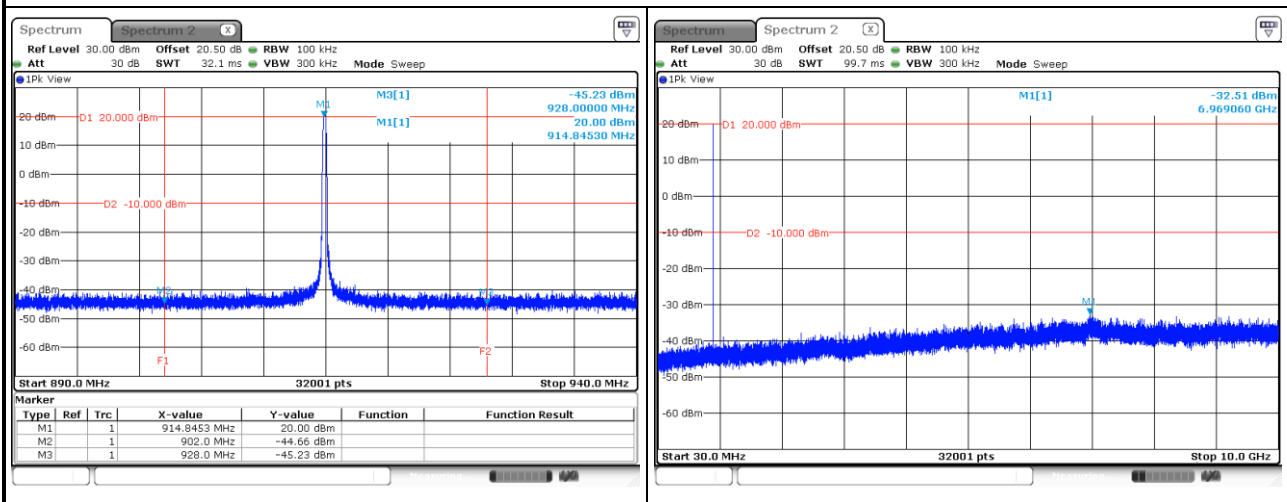

Channel Bandwidth 500kHz

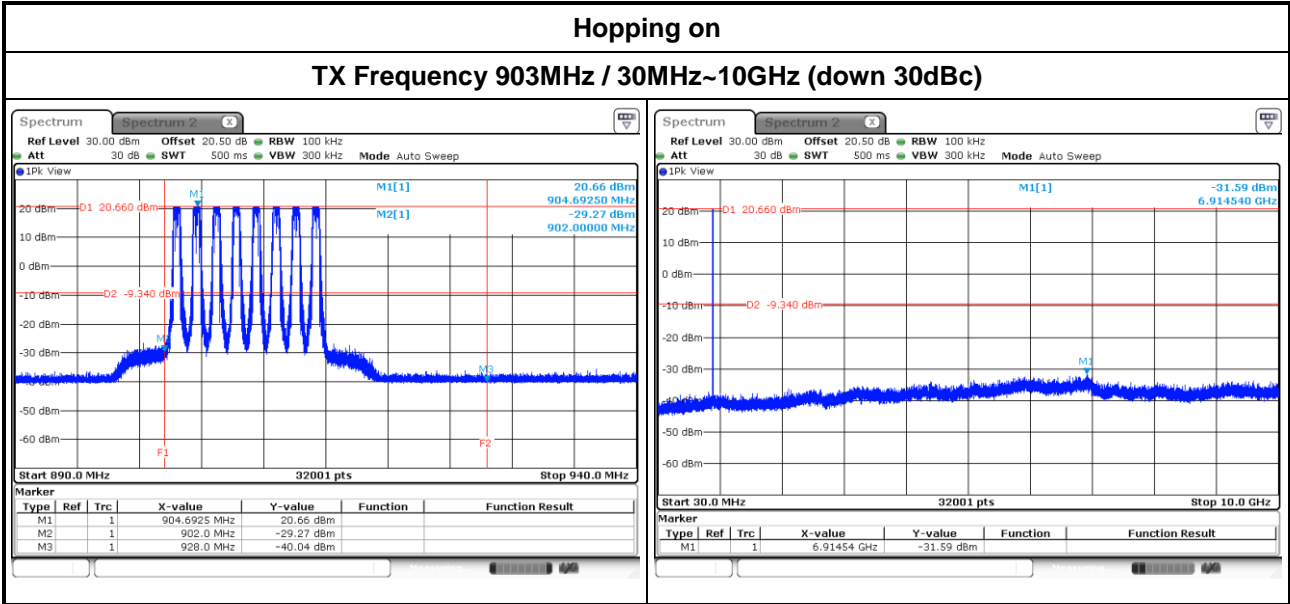

Hopping off

TX Frequency 903MHz / 30MHz~10GHz (down 30dBc)

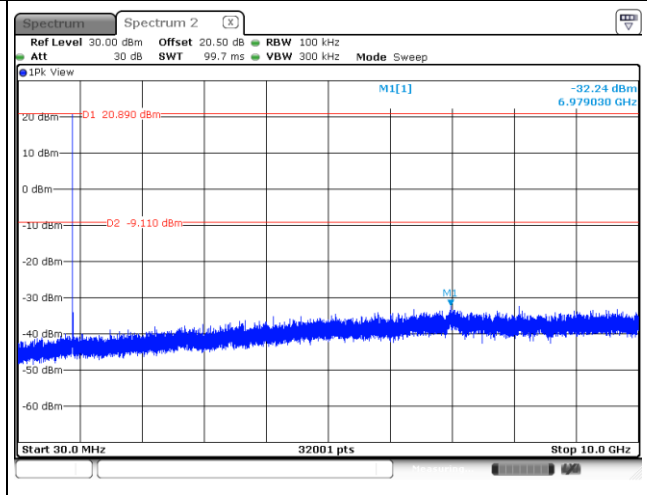
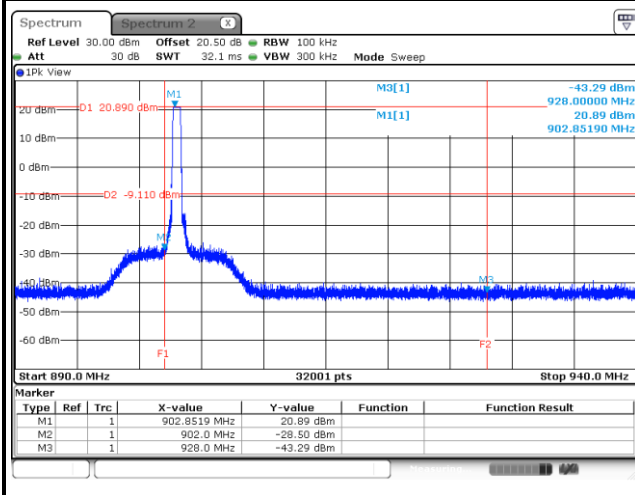

TX Frequency 907.8MHz / 30MHz~10GHz (down 30dBc)

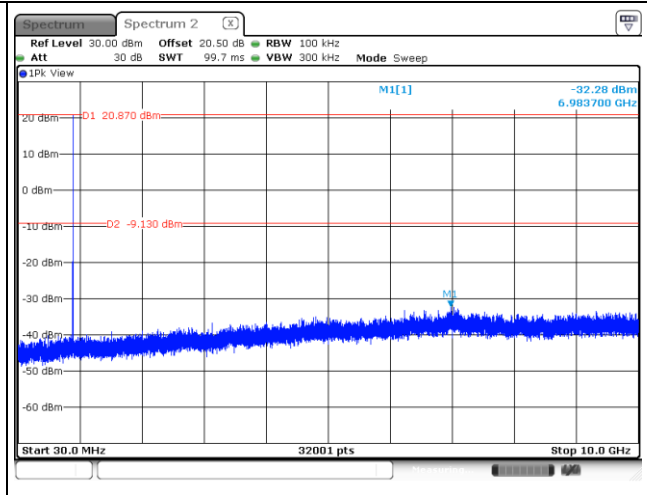
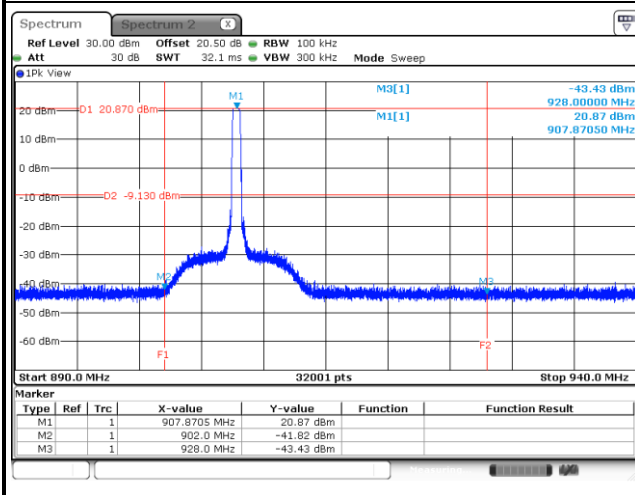

TX Frequency 914.2MHz / 30MHz~10GHz (down 30dBc)

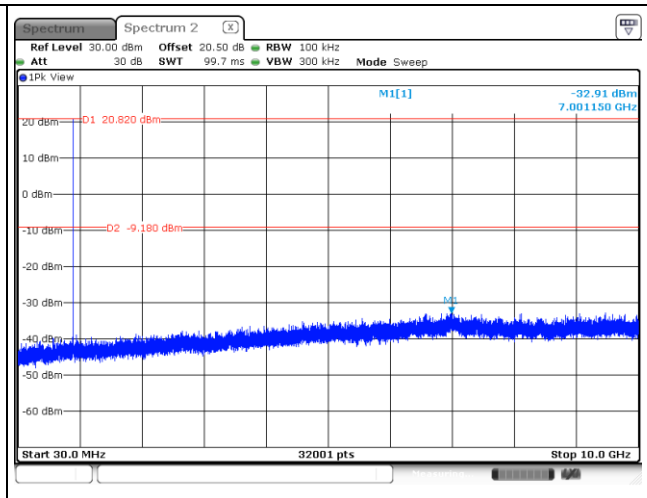
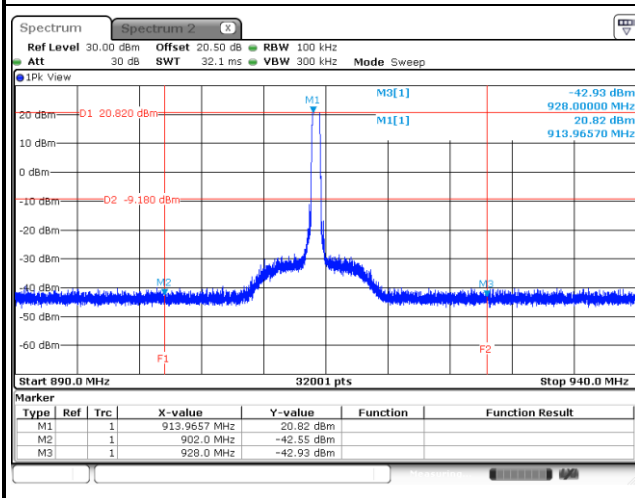

3.4 Conducted Output Power

3.4.1 Limit of Conducted Output Power

1W

3.4.2 Test Procedures

1. A wideband power meter is used for power measurement. Bandwidth of power sensor and meter is 50MHz
2. If duty cycle of test signal is not 100 %, trigger and gating function of power meter will be enabled to capture transmission burst for measuring output power

3.4.3 Test Setup

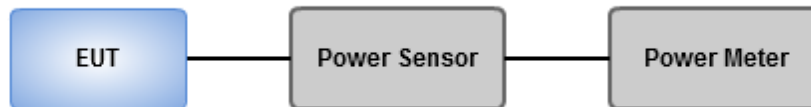

3.4.4 Test Result of Conducted Output Power

Ambient Condition	24-25°C / 65-66%	Tested By	Aska Huang
--------------------------	------------------	------------------	------------

Channel Bandwidth 125kHz

Mode	Freq. (MHz)	Output Power (mW)	Output Power (dBm)	Limit (dBm)
SF10	902.3	105.20	20.22	28
SF10	908.5	103.51	20.15	28
SF10	914.9	102.09	20.09	28

Note: Antenna gain is 8 dBi > 6 dBi, limit shall be reduced to 30 dBm – (8 dBi – 6 dBi) = 28 dBm

Channel Bandwidth 500kHz

Mode	Freq. (MHz)	Output Power (mW)	Output Power (dBm)	Limit (dBm)
SF8	903	128.53	21.09	28
SF8	907.8	127.64	21.06	28
SF8	914.2	125.92	21.00	28

Note: Antenna gain is 8 dBi > 6 dBi, limit shall be reduced to 30 dBm – (8 dBi – 6 dBi) = 28 dBm

3.5 Number of Hopping Frequency

3.5.1 Limit of Number of Hopping Frequency

Number of Hopping Frequencies Limit for Frequency Hopping Systems	
<input checked="" type="checkbox"/>	902-928 MHz Band:
<input type="checkbox"/>	$N \geq 50$, 20 dB bandwidth of the hopping channel is less than 250 kHz
<input type="checkbox"/>	$N \geq 25$, 20 dB bandwidth of the hopping channel is 250 kHz or greater
<input checked="" type="checkbox"/>	Hybrid mode, No minimum number of hopping channels associated with hybrid system.
N: Number of Hopping Frequencies	

3.5.2 Test Procedures

1. Set RBW = 100kHz, VBW = 300kHz, Sweep time = Auto, Detector = Peak Trace max hold.
2. Allow trace to stabilize.

3.5.3 Test Setup

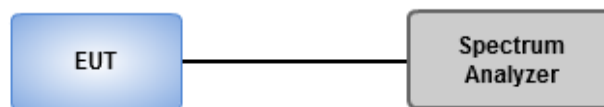

3.5.4 Test Result of Number of Hopping Frequency

Ambient Condition	24-25°C / 65-66%	Tested By	Aska Huang
--------------------------	------------------	------------------	------------

Channel Bandwidth 125kHz

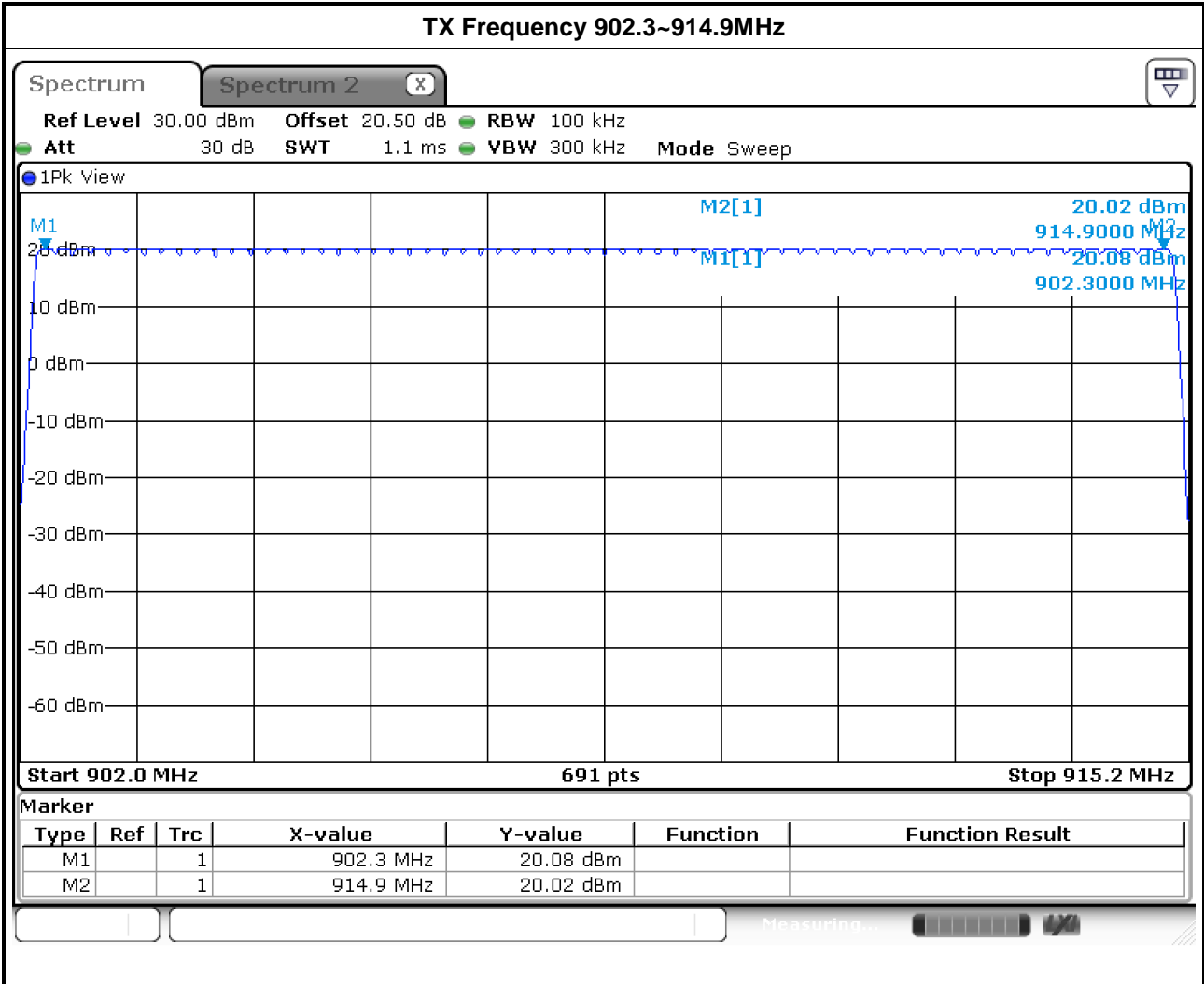

Channel Bandwidth 500kHz

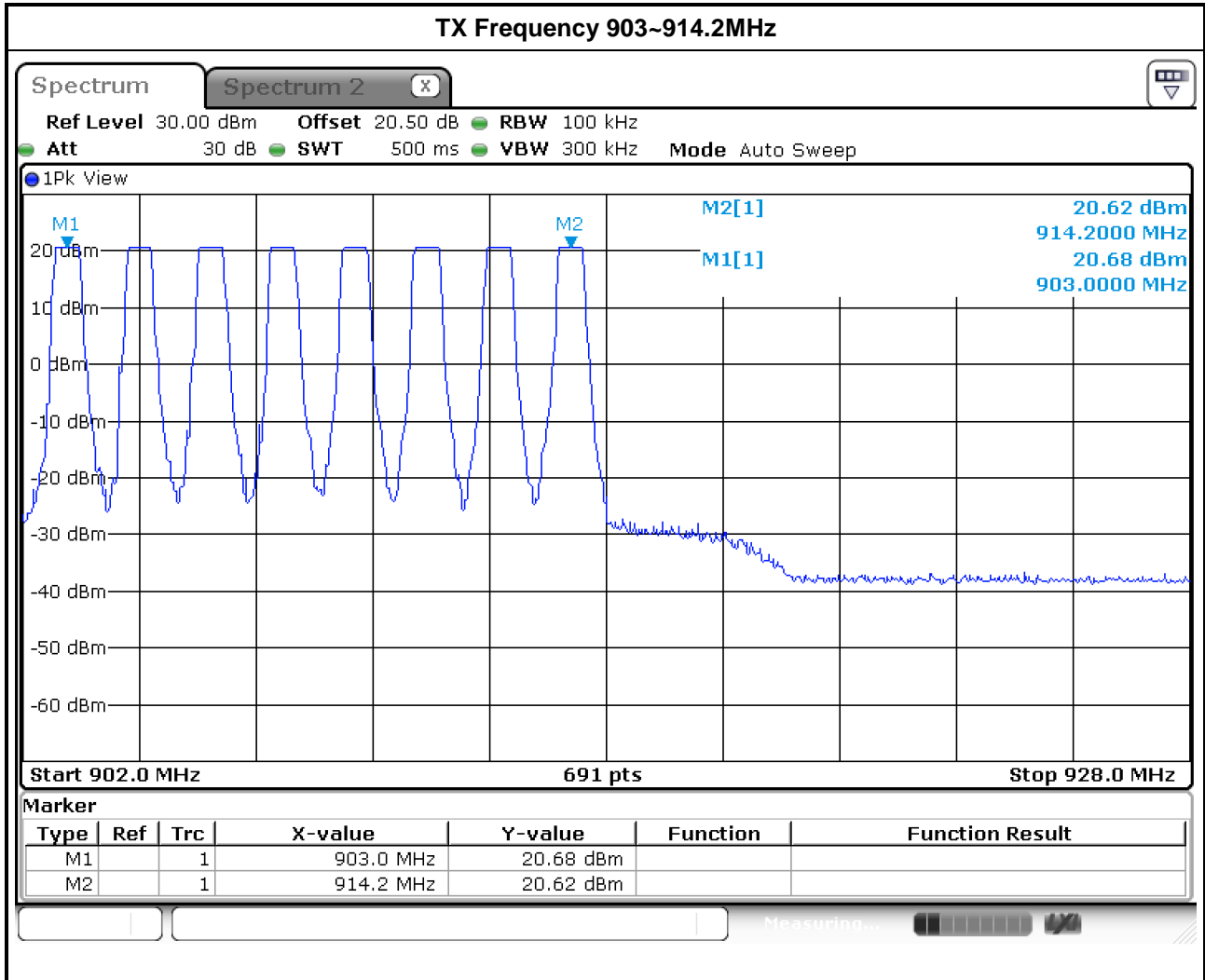

3.6 20dB and Occupied Bandwidth

3.6.1 Test Procedures

20dB Bandwidth

1. Set RBW=3kHz, VBW=10kHz, Sweep time=Auto, Detector=Peak Trace max hold.
2. Allow trace to stabilize.
3. Measure the maximum width of the emission that is constrained by the frequencies associated with the two outermost amplitude points (upper and lower) that are attenuated by 20 dB relative to the maximum level measured in the fundamental emission.

Occupied Bandwidth

1. Set RBW=3kHz, VBW=10kHz, Sweep time = Auto, Detector=Peak, Trace max hold
2. Allow trace to stabilize
3. Use Occupied bandwidth function of spectrum analyzer to measuring 99% occupied bandwidth

3.6.2 Test Setup

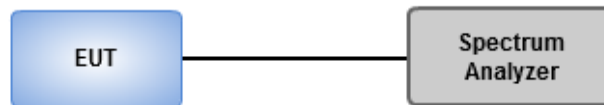

3.6.3 Test result of 20dB and Occupied Bandwidth

Ambient Condition	24-25°C / 65-66%	Tested By	Aska Huang
--------------------------	------------------	------------------	------------

Channel Bandwidth 125kHz

Mode	Freq. (MHz)	20dB Bandwidth (kHz)	Occupied Bandwidth (kHz)
SF10	902.3	139.36	126.34
SF10	908.5	138.93	126.34
SF10	914.9	139.80	126.77

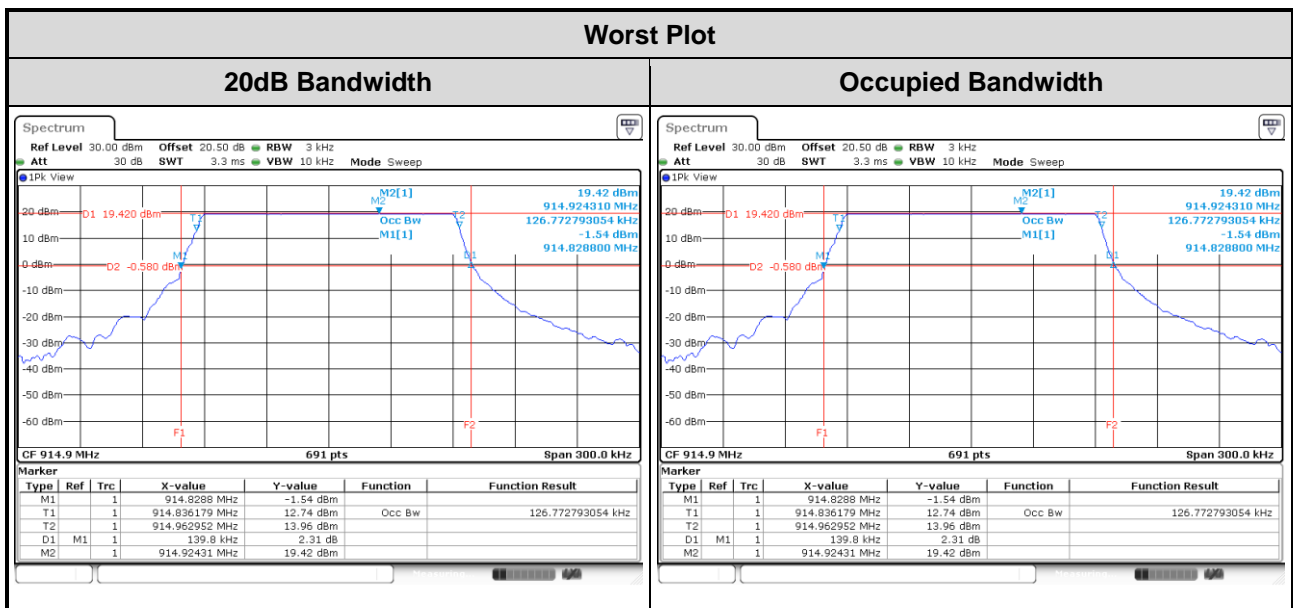

Channel Bandwidth 500kHz

Mode	Freq. (MHz)	20dB Bandwidth (kHz)	Occupied Bandwidth (kHz)
SF8	903	549.90	497.83
SF8	907.8	558.60	500.72
SF8	914.2	558.60	500.72

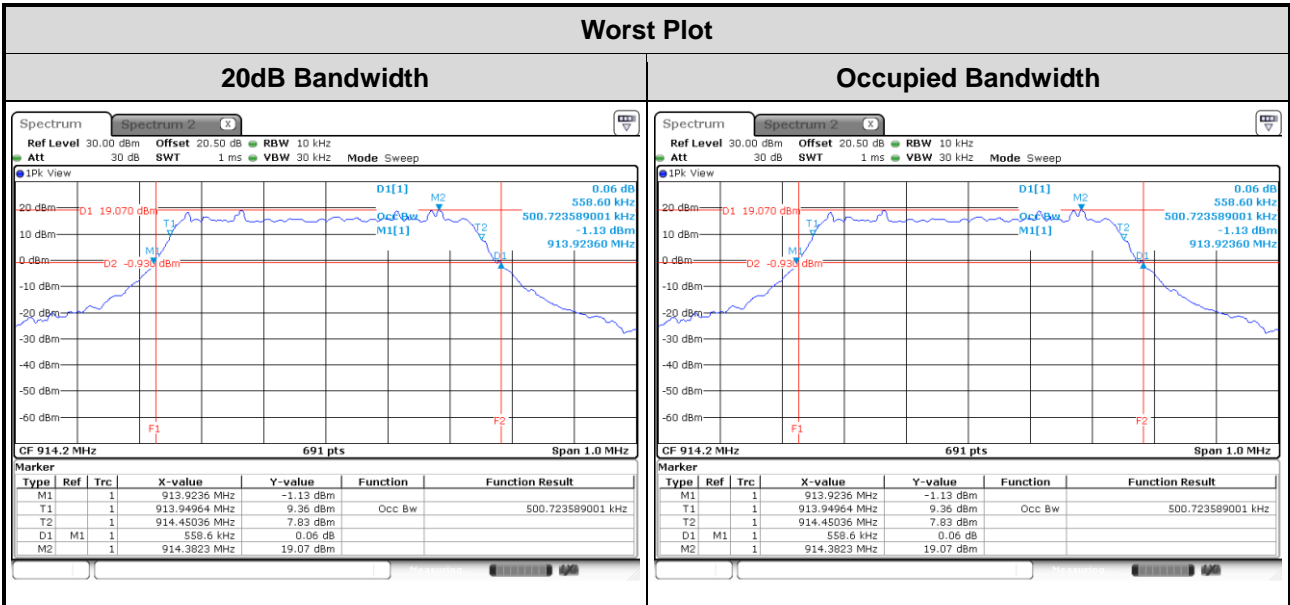

3.7 Channel Separation

3.7.1 Limit of Channel Separation

Frequency hopping systems shall have hopping channel carrier frequencies separated by a minimum of 25 kHz or the 20 dB bandwidth of the hopping channel, whichever is greater.

3.7.2 Test Procedures

1. Set RBW=10kHz, VBW=30kHz, Sweep time=Auto, Detector=Peak Trace max hold.
2. Allow trace to stabilize.
3. Use the marker-delta function to determine the separation between the peaks of the adjacent channels. The EUT shall show compliance with the appropriate regulatory limit

3.7.3 Test Setup

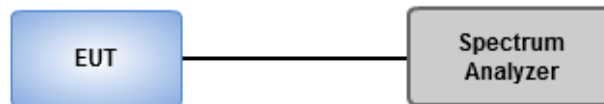

3.7.4 Test result of Channel Separation

Ambient Condition	24-25°C / 65-66%	Tested By	Aska Huang
--------------------------	------------------	------------------	------------

Channel Bandwidth 125kHz

Mode	Freq. (MHz)	Adjacent Channel Separation (kHz)	20dB Bandwidth (kHz)	Pass/Fail
SF10	902.3	200.80	139.36	Pass
SF10	908.5	200.80	138.93	Pass
SF10	914.9	200.80	139.80	Pass

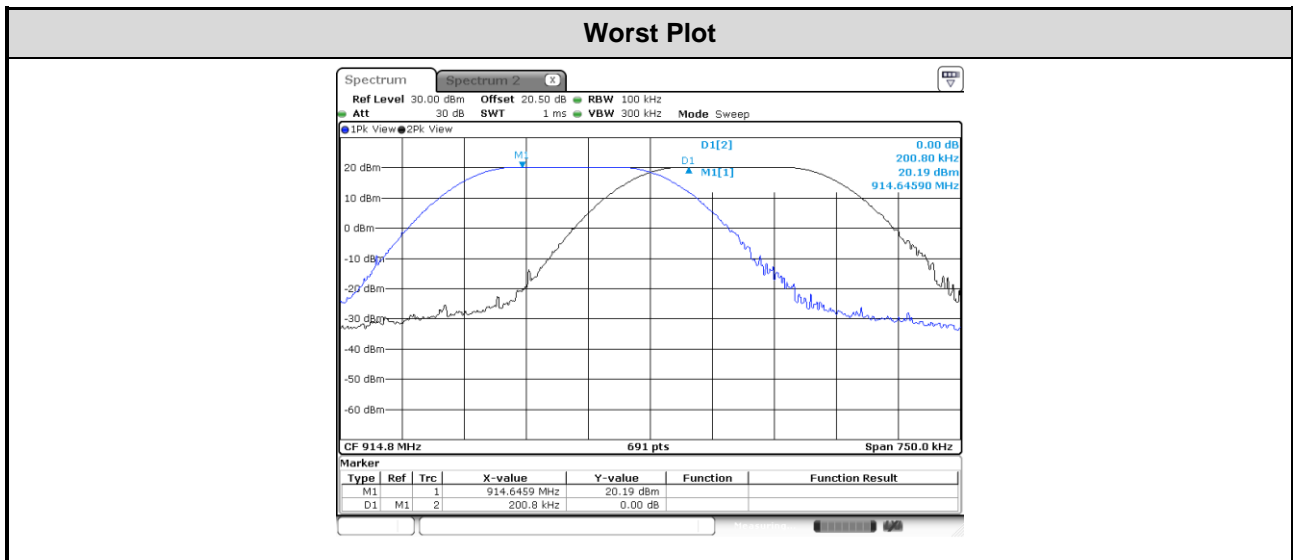

Channel Bandwidth 500kHz

Mode	Freq. (MHz)	Adjacent Channel Separation (kHz)	20dB Bandwidth (kHz)	Pass/Fail
SF8	903	1600.80	549.90	Pass
SF8	907.8	1600.80	558.60	Pass
SF8	914.2	1600.80	558.60	Pass

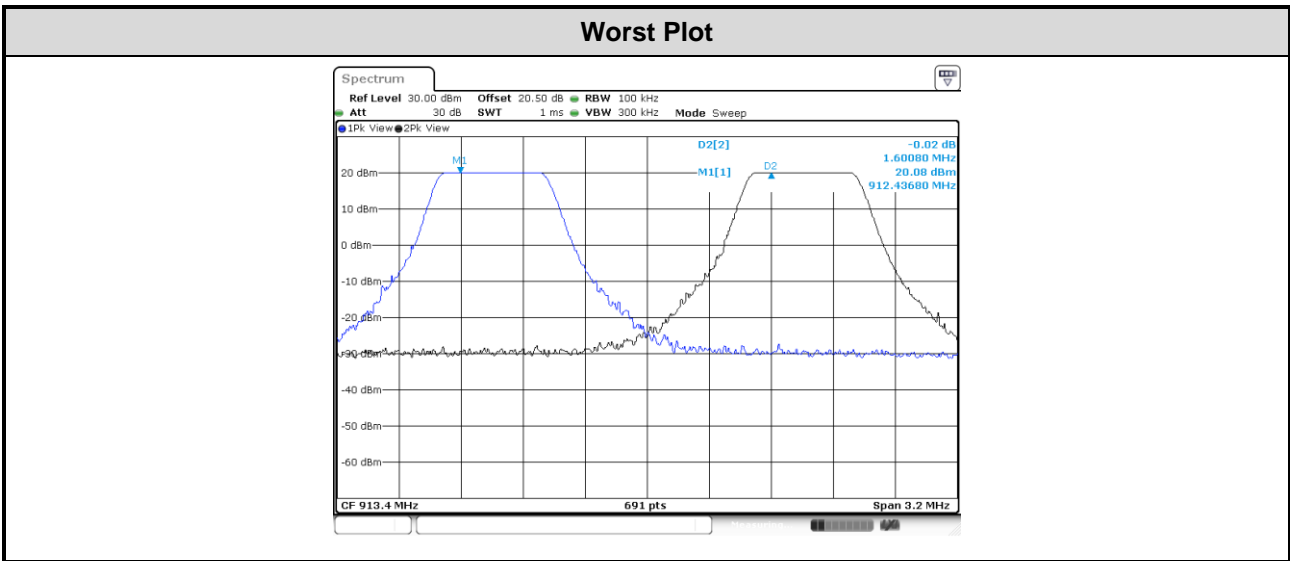

3.8 Number of Dwell Time

3.8.1 Limit of Dwell time

Time of Occupancy (Dwell Time) Limit for Frequency Hopping Systems	
<input checked="" type="checkbox"/>	902-928 MHz Band:
<input type="checkbox"/>	≤ 0.4 second within a 20 second period, 20 dB bandwidth of the hopping channel is less than 250 kHz
<input type="checkbox"/>	≤ 0.4 second within a 10 second period, 20 dB bandwidth of the hopping channel is 250 kHz or greater
<input checked="" type="checkbox"/>	Hybrid mode ,an average time of occupancy on any frequency not to exceed 0.4 seconds within a time period in seconds equal to the number of hopping frequencies employed multiplied by 0.4

3.8.2 Test Procedures

1. Set RBW=200kHz, VBW=1000kHz, Sweep time=3.2s / 500ms, Detector=Peak, Span=0Hz, Trace max hold for 8 hopping channels.
2. Set RBW=200kHz, VBW=1000kHz, Sweep time=6.4s / 500ms, Detector=Peak, Span=0Hz, Trace max hold for 16 hopping channels.
3. Set RBW=200kHz, VBW=1000kHz, Sweep time=25.6s / 500ms, Detector=Peak, Span=0Hz, Trace max hold for 64 hopping channels.
4. Measure and record the burst on time.

3.8.3 Test Setup

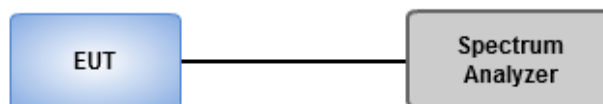

3.8.4 Test Result of Dwell Time

Ambient Condition	24-25°C / 65-66%	Tested By	Aska Huang
--------------------------	------------------	------------------	------------

Channel Bandwidth 125kHz

Mode	Freq. (MHz)	Length of Transmission Time (sec)	Number of Transmission in a 3.2 s (8 Hopping channels *0.4s)	Result (s)	Limit (s)
SF7	902.3	0.3997500	1	0.3997500	0.4
SF8	902.3	0.3897812	1	0.3897812	0.4
SF9	902.3	0.3902813	1	0.3902813	0.4
SF10	902.3	0.3708281	1	0.3708281	0.4

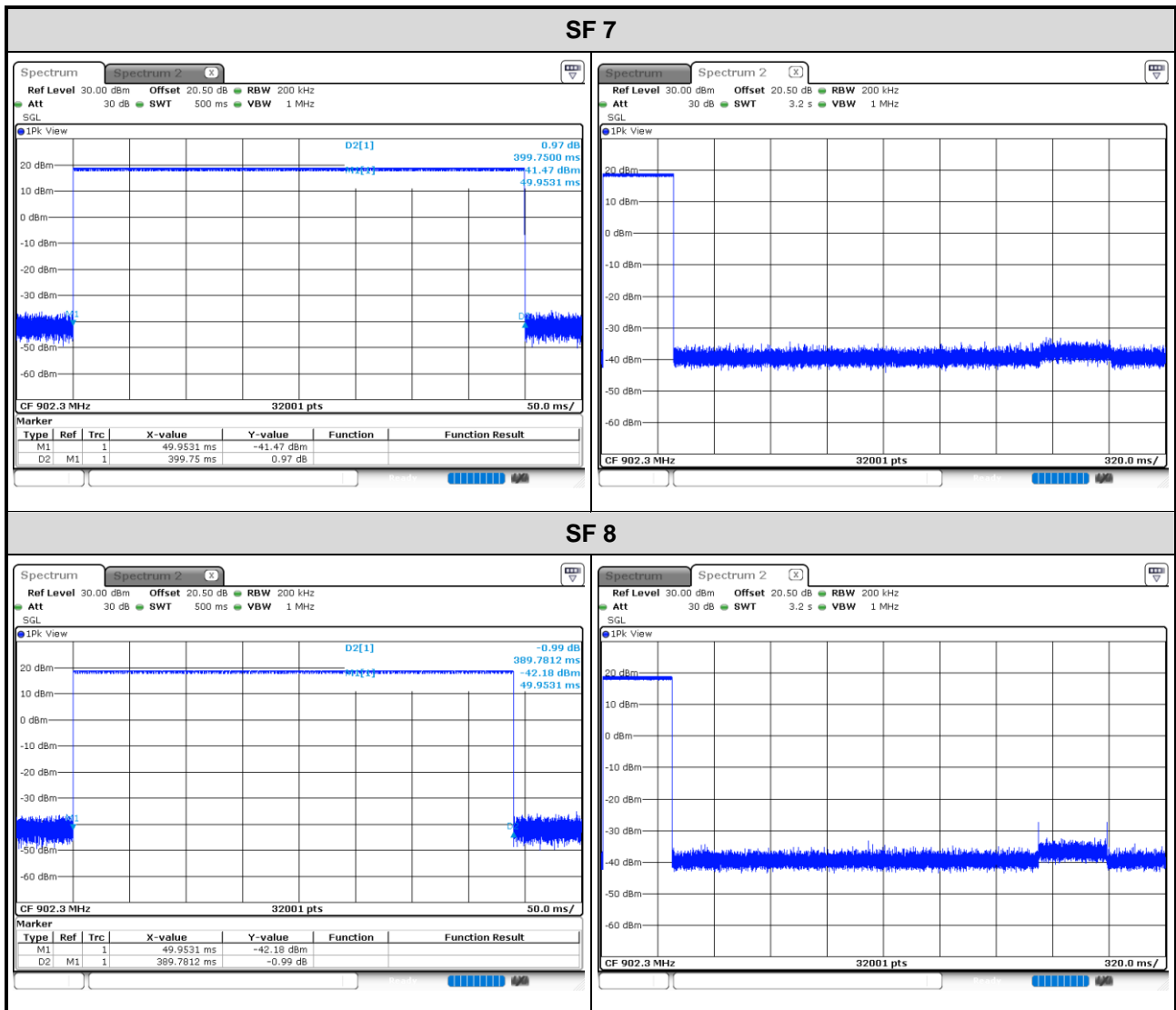

SF 9

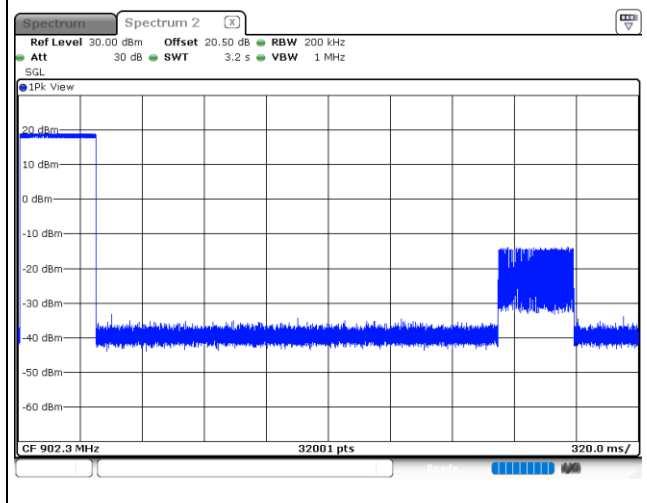
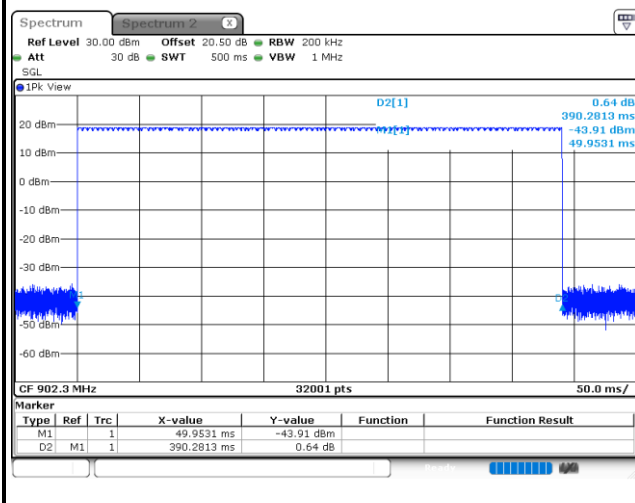

SF 10

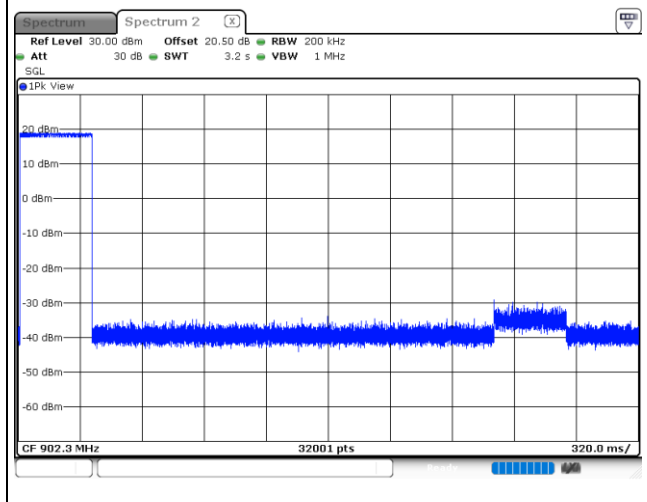
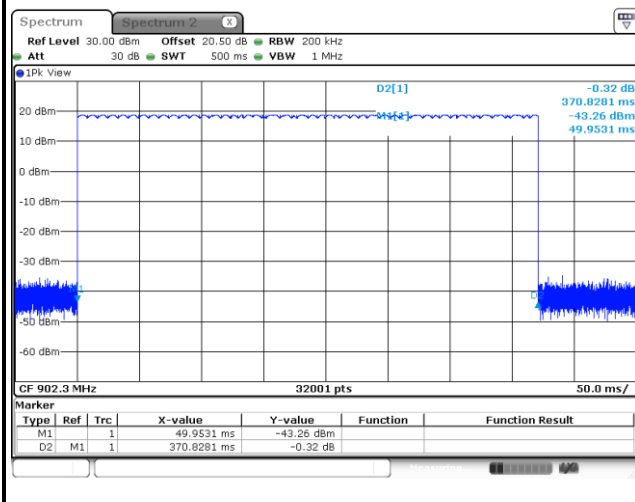

Mode	Freq. (MHz)	Length of Transmission Time (sec)	Number of Transmission in a 6.4 s (16 Hopping channels *0.4s)	Result (s)	Limit (s)
SF7	902.3	0.3997656	1	0.3997656	0.4
SF8	902.3	0.3897812	1	0.3897812	0.4
SF9	902.3	0.3902969	1	0.3902969	0.4
SF10	902.3	0.3708281	1	0.3708281	0.4

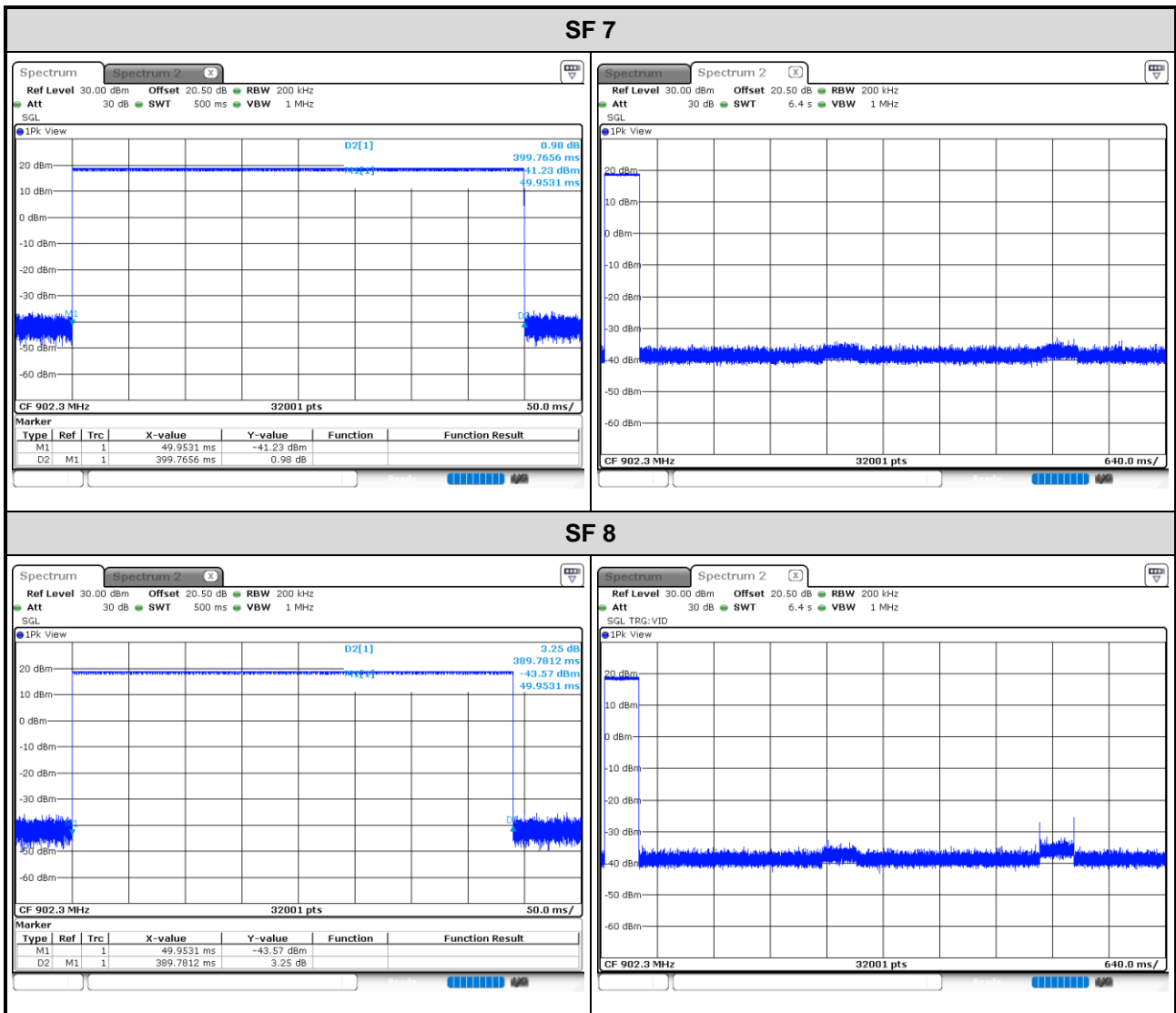

SF 9

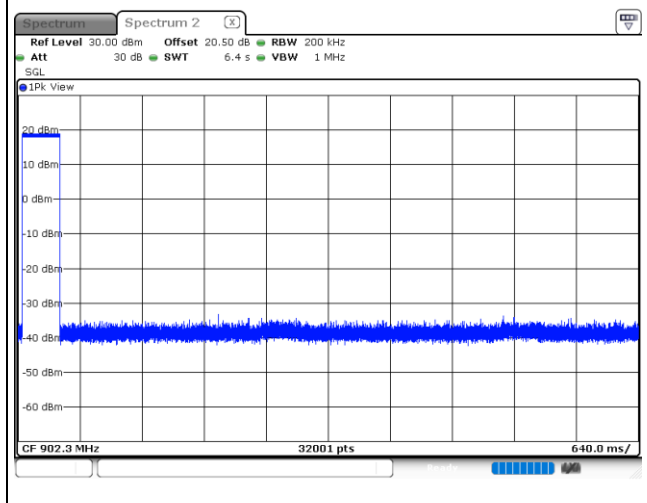
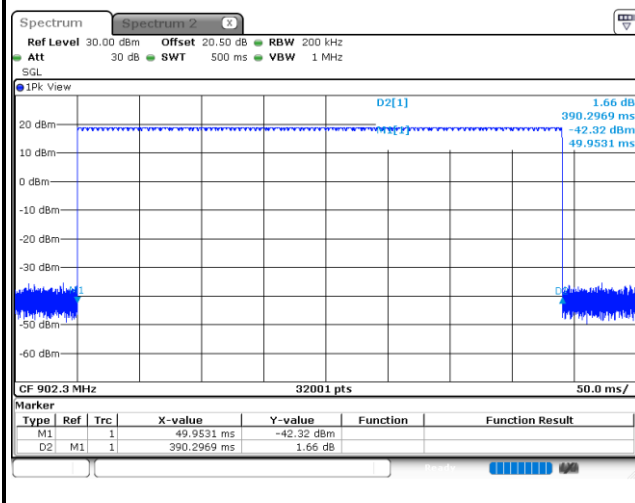

SF 10

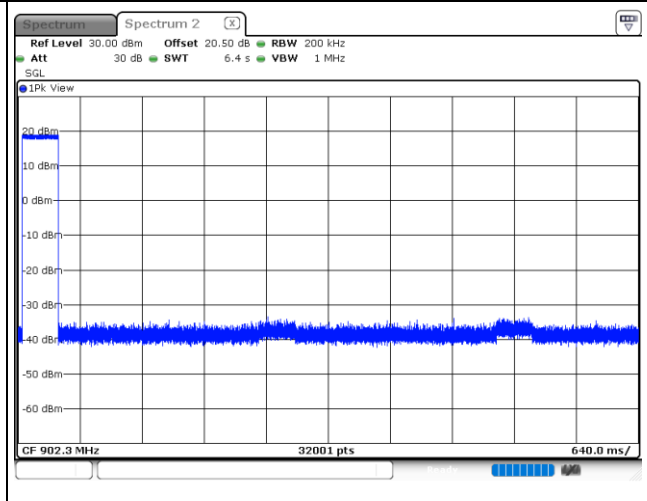
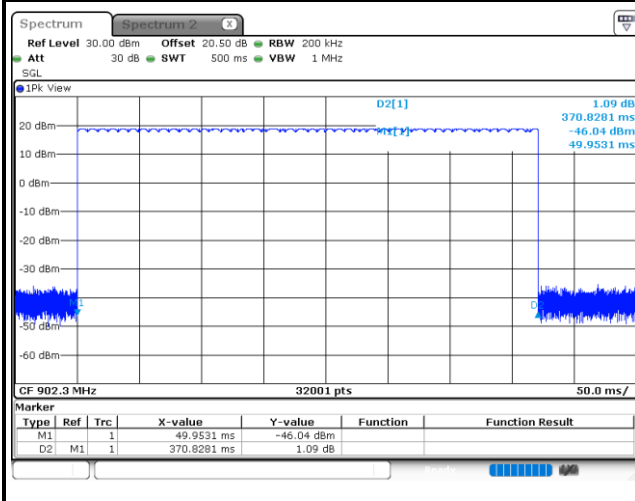

Mode	Freq. (MHz)	Length of Transmission Time (sec)	Number of Transmission in a 25.6 s (64 Hopping channels *0.4s)	Result (s)	Limit (s)
SF7	902.3	0.3999219	1	0.3999219	0.4
SF8	902.3	0.3897812	1	0.3897812	0.4
SF9	902.3	0.3905000	1	0.3905000	0.4
SF10	902.3	0.3709844	1	0.3709844	0.4

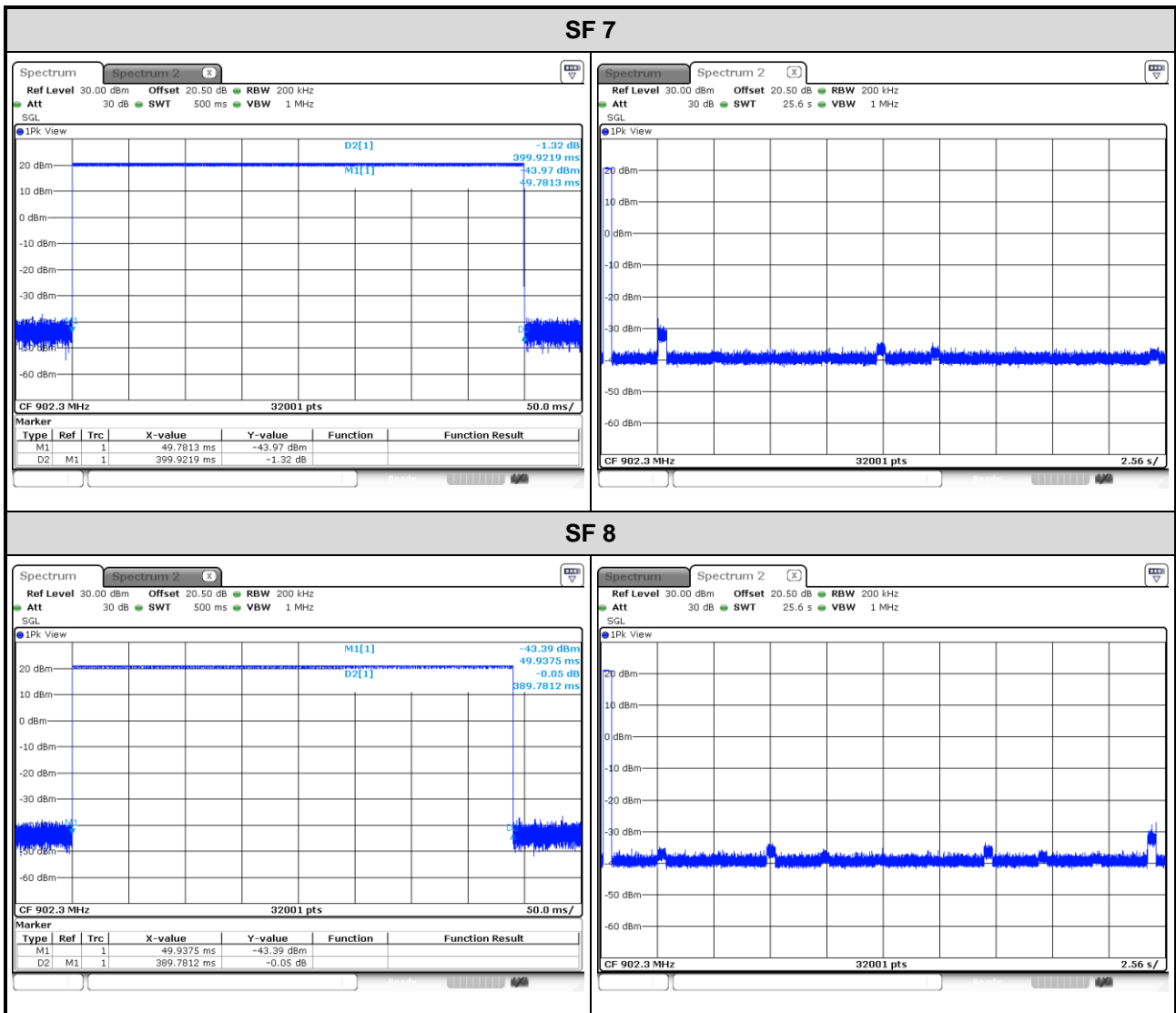

SF 9

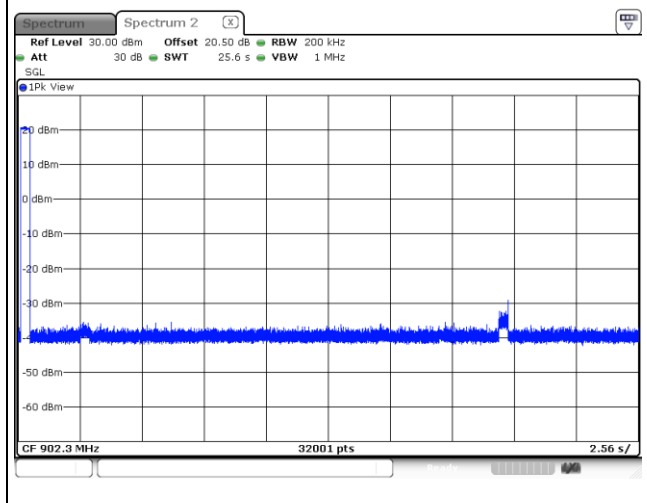
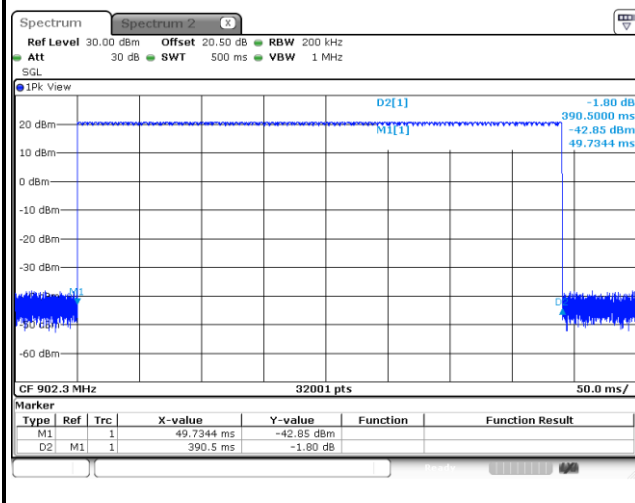

SF 10

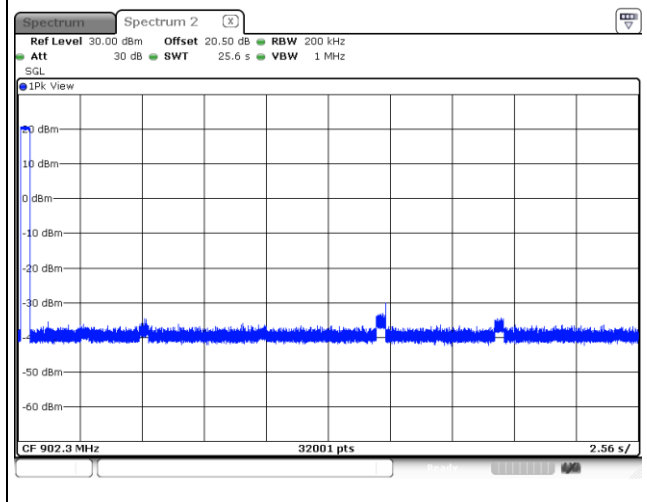
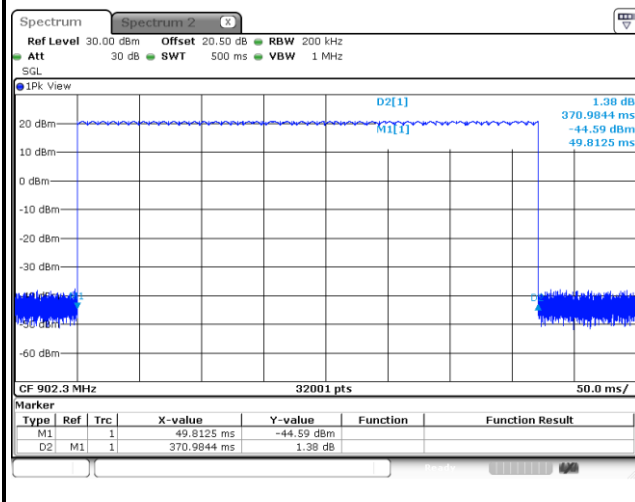

Channel Bandwidth 500kHz

Mode	Freq. (MHz)	Length of Transmission Time (sec)	Number of Transmission in a 3.2 s (8 Hopping channels *0.4s)	Result (s)	Limit (s)
SF8	903	0.1769062	1	0.1769062	0.4

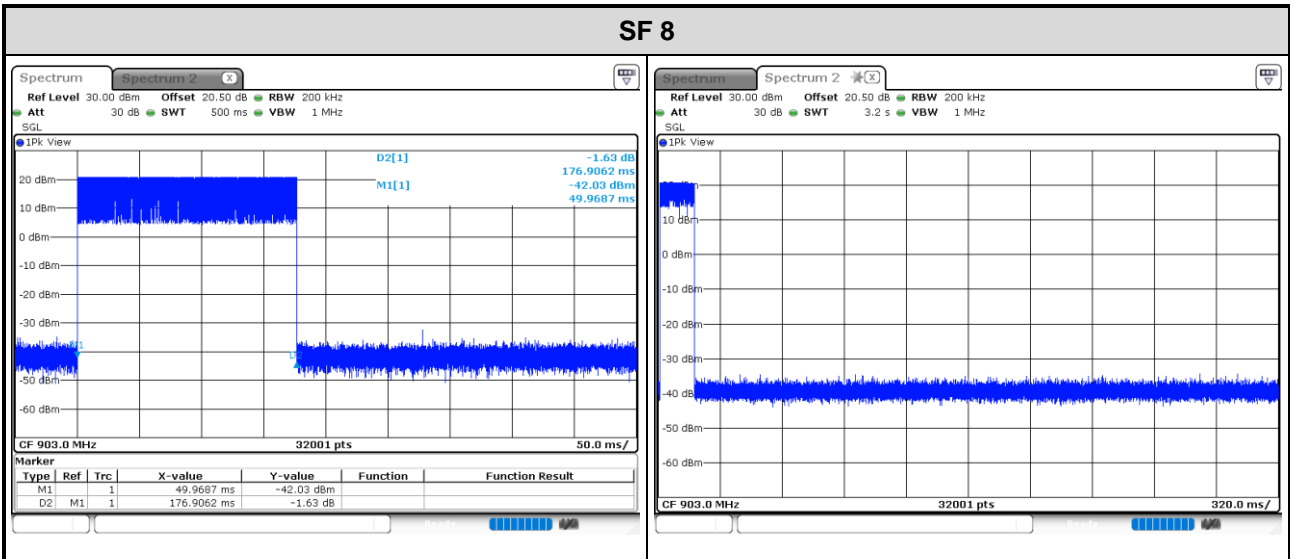

3.9 Power Spectral Density

3.9.1 Limit of Power Spectral Density

Power spectral density shall not be greater than 8 dBm in any 3 kHz band. This item is for Hybrid mode.

3.9.2 Test Procedures

1. Set the RBW = 3kHz, VBW = 10 kHz.
2. Detector = RMS, Sweep time = auto couple.
3. Employ trace averaging (RMS) mode over a minimum of 100 traces
4. Use the peak marker function to determine the maximum amplitude level.

3.9.3 Test Setup

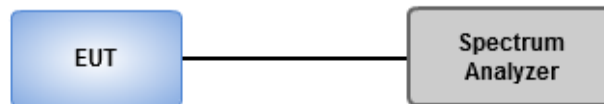

3.9.4 Test Result of Power Spectral Density

Ambient Condition	24-25°C / 65-66%	Tested By	Aska Huang
--------------------------	------------------	------------------	------------

Channel Bandwidth 125kHz

Mode	Freq. (MHz)	Total Power Spectral Density (dBm/3kHz)	Limit (dBm/3kHz)
SF10	902.3	5.62	6
SF10	908.5	5.76	6
SF10	914.9	5.56	6

Note: Antenna gain is 8 dBi > 6 dBi, limit shall be reduced to 8 dBm – (8 dBi – 6 dBi) = 6 dBm

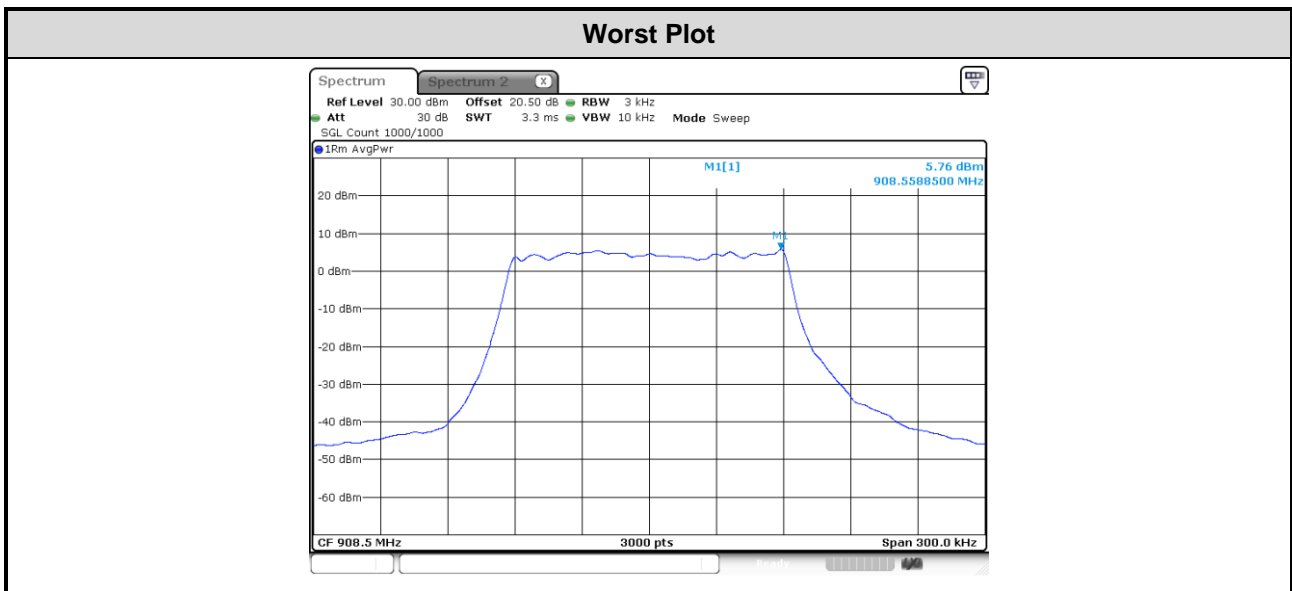

Channel Bandwidth 500kHz

Mode	Freq. (MHz)	Total Power Spectral Density (dBm/3kHz)	Limit (dBm/3kHz)
SF8	903	1.93	6
SF8	907.8	2.11	6
SF8	914.2	1.83	6

Note: Antenna gain is 8 dBi > 6 dBi, limit shall be reduced to 8 dBm – (8 dBi – 6 dBi) = 6 dBm

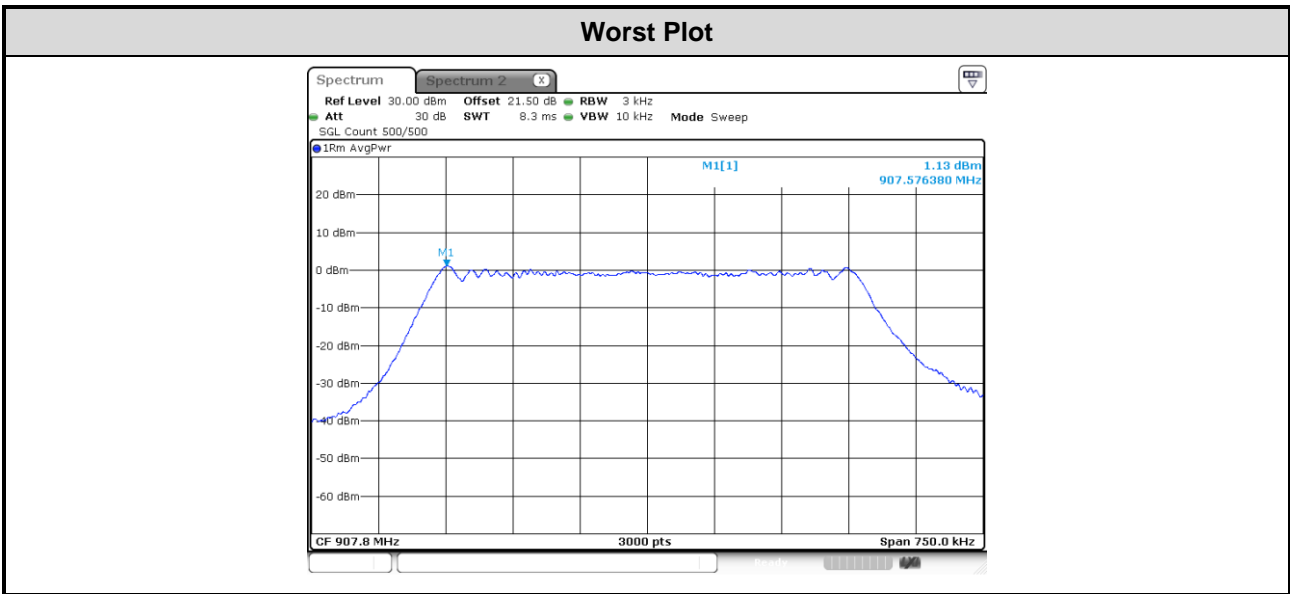

4 Test laboratory information

Established in 2012, ICC provides foremost EMC & RF Testing and advisory consultation services by our skilled engineers and technicians. Our services employ a wide variety of advanced edge test equipment and one of the widest certification extents in the business.

International Certification Corporation (EMC and Wireless Communication Laboratory), it is our definitive objective is to institute long term, trust-based associations with our clients. The expectation we set up with our clients is based on outstanding service, practical expertise and devotion to a certified value structure. Our passion is to grant our clients with best EMC / RF services by oriented knowledgeable and accommodating staff.

Our Test sites are located at Linkou District and Kwei Shan District. Location map can be found on our website <http://www.icertifi.com.tw>.

Linkou

Tel: 886-2-2601-1640

No.30-2, Ding Fwu Tsuen, Lin Kou
District, New Taipei City, Taiwan
(R.O.C.)

Kwei Shan

Tel: 886-3-271-8666

No.3-1, Lane 6, Wen San 3rd
St., Kwei Shan Dist., Tao Yuan
City 33381, Taiwan (R.O.C.)
No.2-1, Lane 6, Wen San 3rd
St., Kwei Shan Dist., Tao Yuan
City 33381, Taiwan (R.O.C.)

Kwei Shan Site II

Tel: 886-3-271-8640

No.14-1, Lane 19, Wen San 3rd
St., Kwei Shan Dist., Tao Yuan
City 333, Taiwan (R.O.C.)

If you have any suggestion, please feel free to contact us as below information.

Tel: 886-3-271-8666

Fax: 886-3-318-0345

Email: ICC_Service@icertifi.com.tw

==END==