

1 Cover Page

RF REPORT

Application No.: SHEM2006004922CR
FCC ID: 2ADTD-D1152091
Applicant: Hangzhou Hikvision Digital Technology Co., Ltd.
Address of Applicant: No.555 Qianmo Road, Binjiang District, Hangzhou 310052, China
Manufacturer: Hangzhou Hikvision Digital Technology Co., Ltd.
Address of Manufacturer: No.555 Qianmo Road, Binjiang District, Hangzhou 310052, China
Factory: Hangzhou Hikvision Electronics Co., Ltd.
Address of Factory: No.299, Qiushi Road, Tonglu Economic Development Zone, Tonglu County, Hangzhou, Zhejiang, 310052, China.

Equipment Under Test (EUT):

EUT Name: Wireless Slim Magnet Detector
Model No.: DS-PDMCS-EG2-WB, DS-PDMCS-EG2-WBUHK, DS-PDMCS-EG2-WBCKV, DS-PDMCS-EG2-WBUVS, DS-PDMCS-EG2-WBKVO, DS-PDMCS-EG2-WBHUN

☐ Please refer to section 2 of this report which indicates which model was actually tested and which were electrically identical.

Trade mark: HIKVISION
Standard(s): 47 CFR Part 15, Subpart C 15.231
Date of Receipt: 2020-06-20
Date of Test: 2020-06-22 to 2020-07-15
Date of Issue: 2020-07-16

Test Result:	Pass*
---------------------	--------------

* In the configuration tested, the EUT complied with the standards specified above.

Parlam Zhan

Parlam Zhan
E&E Section Manager

The manufacturer should ensure that all products in series production are in conformity with the product sample detailed in this report. If the product in this report is used in any configuration other than that detailed in the report, the manufacturer must ensure the new system complies with all relevant standards. Any mention of SGS International Electrical Approvals or testing done by SGS International Electrical Approvals in connection with, distribution or use of the product described in this report must be approved by SGS International Electrical Approvals in writing.



Unless otherwise agreed in writing, this document is issued by the Company subject to its General Conditions of Service printed overleaf, available on request or accessible at <http://www.sgs.com/en/Terms-and-Conditions.aspx> and, for electronic format documents, subject to Terms and Conditions for Electronic Documents at <http://www.sgs.com/en/Terms-and-Conditions/Terms-e-Documents.aspx>. Attention is drawn to the limitation of liability, indemnification and jurisdiction issues defined therein. Any holder of this document is advised that information contained hereon reflects the Company's findings at the time of its intervention only and within the limits of Client's instructions, if any. The Company's sole responsibility is to its Client and this document does not exonerate parties to a transaction from exercising all their rights and obligations under the transaction documents. This document cannot be reproduced except in full, without prior written approval of the Company. Any unauthorized alteration, forgery or falsification of the content or appearance of this document is unlawful and offenders may be prosecuted to the fullest extent of the law. Unless otherwise stated the results shown in this test report refer only to the sample(s) tested and such sample(s) are retained for 30 days only.
Attention: To check the authenticity of testing / inspection report & certificate, please contact us at telephone: (86-755) 8307 1443, or email: CN.Doccheck@sgs.com



Revision Record			
Version	Description	Date	Remark
00	Original	2020-07-16	/

Authorized for issue by:				
				
		<hr/> Micheal Niu / Project Engineer		
				
		<hr/> Parlam Zhan /Reviewer		



2 Test Summary

Test Item	FCC Requirement	Test method	Result
Antenna Requirement	Part 15.203	/	PASS
Conducted Emission	Part 15.207	ANSI C63.10 (2013) Section 6.2	N/A
Field Strength of the Fundamental	Part 15.231 (b)	ANSI C63.10 (2013) Section 6.4	PASS
Radiated Spurious emissions	Part 15.209 15.231(b)	ANSI C63.10 (2013) Section 6.4&6.5&6.6	PASS
20dB Bandwidth	Part 15.231 (c)	ANSI C63.10 (2013) Section 6.9.2	PASS
Dwell Time	Part 15.231 (a)	ANSI C63.10 (2013) Section 7.8.4	PASS

Note: Declaration of EUT Family Grouping:

There are series models mentioned in this report, and they are the identical in electrical and electronic characters. Only the model DS-PDMCS-EG2-WB was tested since their differences were the model number.

N/A: This EUT is powered by battery only; therefore the AC Conducted Emission test is not applicable.



3 Contents

	Page
1 COVER PAGE	1
2 TEST SUMMARY.....	3
3 CONTENTS.....	4
4 GENERAL INFORMATION.....	5
4.1 GENERAL DESCRIPTION OF E.U.T.....	5
4.2 TECHNICAL SPECIFICATIONS:.....	5
4.3 DESCRIPTION OF SUPPORT UNITS	5
4.4 MEASUREMENT UNCERTAINTY	5
4.5 TEST LOCATION	6
4.6 TEST FACILITY	6
5 EQUIPMENTS USED DURING TEST	7
6 TEST RESULTS AND MEASUREMENT DATA.....	8
6.1 ANTENNA REQUIREMENT.....	8
6.2 CONDUCTED EMISSIONS AT AC POWER LINE (150kHz-30MHz).....	9
6.3 SPURIOUS EMISSIONS.....	10
6.4 20dB BANDWIDTH	16
6.5 DWELL TIME	17
7 TEST SETUP PHOTOGRAPHS	19
8 EUT CONSTRUCTIONAL DETAILS	19

4 General Information

4.1 General Description of E.U.T.

Power supply:	DC 3V by CR2450 Button battery
Test voltage:	DC 3V

4.2 Technical Specifications:

Modulation Type	2GFSK
Number of Channels	1
Operation Frequency	433.10MHz
Antenna Type	Spiral antenna

4.3 Description of Support Units

The EUT has been tested independently

4.4 Measurement Uncertainty

No.	Item	Measurement Uncertainty
1	Radio Frequency	8.4 x 10 ⁻⁸
2	Timeout	2s
3	Duty cycle	0.4%
4	Occupied Bandwidth	3%
5	RF conducted power	0.6dB
6	RF power density	2.9dB
7	Conducted Spurious emissions	0.75dB
8	RF Radiated power	5.1dB (Below 1GHz)
		5.9dB (Above 1GHz)
9	Radiated Spurious emission test	4.2dB (Below 30MHz)
		4.5dB (30MHz-1GHz)
		5.1dB (1GHz-6GHz)
		5.4dB (6GHz-18GHz)
10	Temperature test	1°C
11	Humidity test	3%
12	Supply voltages	1.5%
13	Time	3%

Note: The measurement uncertainty represents an expanded uncertainty expressed at approximately the 95% confidence level using a coverage factor of k=2.



4.5 Test Location

All tests were performed at:

SGS-CSTC Standards Technical Services Co., Ltd. Shanghai Branch

588 West Jindu Road, Xinqiao, Songjiang, 201612 Shanghai, China

Tel: +86 21 6191 5666

Fax: +86 21 6191 5678

No tests were sub-contracted.

4.6 Test Facility

The test facility is recognized, certified, or accredited by the following organizations:

- **CNAS (No. CNAS L0599)**

CNAS has accredited SGS-CSTC Standards Technical Services (Shanghai) Co., Ltd. to ISO/IEC 17025:2017 General Requirements for the Competence of Testing and Calibration Laboratories (CNAS-CL01 Accreditation Criteria for the Competence of Testing and Calibration Laboratories) for the competence in the field of testing.

- **NVLAP (LAB CODE: 201034-0)**

SGS-CSTC Standards Technical Services (Shanghai) Co., Ltd. is accredited by the National Voluntary Laboratory Accreditation Program (NVLAP).

- **FCC (Designation Number: CN5033)**

SGS-CSTC Standards Technical Services (Shanghai) Co., Ltd. has been recognized as an accredited testing laboratory.

- **ISED (CAB Identifier: CN0020)**

SGS-CSTC Standards Technical Services (Shanghai) Co., Ltd. EMC Laboratory has been recognized by Innovation, Science and Economic Development Canada (ISED) as an accredited testing laboratory

- **VCCI (Member No.: 3061)**

The 3m Semi-anechoic chamber and Shielded Room of SGS-CSTC Standards Technical Services (Shanghai) Co., Ltd. has been registered in accordance with the Regulations for Voluntary Control Measures with Registration No.: R-13868, C-14336, T-12221, G-10830 respectively.

5 Equipments Used during Test

Equipment	Manufacturer	Model No	Inventory No	Cal Date	Cal Due Date
RF Conducted Test					
Spectrum Analyzer	R&S	FSP-30	SHEM002-1	2019-12-20	2020-12-19
Spectrum Analyzer	Agilent	N9020A	SHEM181-1	2019-08-13	2020-08-12
Signal Generator	R&S	SMR20	SHEM006-1	2019-08-13	2020-08-12
Signal Generator	Agilent	N5182A	SHEM182-1	2019-08-13	2020-08-12
Communication Tester	R&S	CMW270	SHEM183-1	2019-08-13	2020-08-12
Switcher	Tonscend	JS0806	SHEM184-1	2019-08-13	2020-08-12
Power Sensor	Keysight	U2021XA * 4	SHEM184-1	2019-08-13	2020-08-12
Splitter	Anritsu	MA1612A	SHEM185-1	/	/
Coupler	e-meca	803-S-1	SHEM186-1	/	/
High-low Temp Cabinet	Suzhou Zhihe	TL-40	SHEM087-1	2017-09-25	2020-09-24
AC Power Stabilizer	APC	KDF-31020T-V0-F0	SHEM216-1	2019-12-20	2020-12-19
DC Power Supply	MCH	MCH-303A	SHEM210-1	2019-12-20	2020-12-19
Conducted test Cable	/	RF01~RF04	/	2019-12-20	2020-12-19
RF Radiated Test					
EMI test Receiver	R&S	ESU40	SHEM051-1	2019-12-20	2020-12-19
Spectrum Analyzer	R&S	FSP-30	SHEM002-1	2019-12-20	2020-12-19
Loop Antenna (9kHz-30MHz)	Schwarzbeck	FMZB1519	SHEM135-1	2019-12-20	2020-12-19
Antenna (25MHz-2GHz)	Schwarzbeck	VULB9168	SHEM048-1	2019-10-14	2021-10-13
Antenna (25MHz-2GHz)	Schwarzbeck	VULB9168	SHEM202-1	2019-04-30	2021-04-29
Horn Antenna (1-18GHz)	Schwarzbeck	HF906	SHEM009-1	2017-10-24	2020-10-23
Horn Antenna (1-18GHz)	Schwarzbeck	BBHA9120D	SHEM050-1	2019-10-14	2021-10-13
Horn Antenna (14-40GHz)	Schwarzbeck	BBHA 9170	SHEM049-1	2017-10-31	2020-10-30
Pre-amplifier (9KHz-2GHz)	CLAVIIO	BDLNA-0001	SHEM164-1	2019-08-13	2020-08-12
Pre-amplifier (1-18GHz)	CLAVIIO	BDLNA-0118	SHEM050-2	2019-08-13	2020-08-12
High-amplifier (14-40GHz)	Schwarzbeck	10001	SHEM049-2	2019-12-19	2020-12-18
Signal Generator	R&S	SMR40	SHEM058-1	2019-08-13	2020-08-12
Band Filter	LORCH	9BRX-875/X150	SHEM156-1	/	/
Band Filter	LORCH	13BRX-1950/X500	SHEM083-2	/	/
Band Filter	LORCH	5BRX-2400/X200	SHEM155-1	/	/
Band Filter	LORCH	5BRX-5500/X1000	SHEM157-2	/	/
High pass Filter	Wainwright	WHK3.0/18G	SHEM157-1	/	/
High pass Filter	Wainwright	WHKS1700	SHEM157-3	/	/
Semi/Fully Anechoic	ST	11*6*6M	SHEM078-2	2017-07-22	2020-07-21
RE test Cable	/	RE01, RE02, RE06	/	2019-12-19	2020-12-18



6 Test results and Measurement Data

6.1 Antenna Requirement

15.203 Requirement:

An intentional radiator shall be designed to ensure that no antenna other than that furnished by the responsible party shall be used with the device. The use of a permanently attached antenna or of an antenna that uses a unique coupling to the intentional radiator, the manufacturer may design the unit so that a broken antenna can be replaced by the user, but the use of a standard antenna jack or electrical connector is prohibited.

The antenna is spiral antenna, and no consideration of replacement.

Antenna location: Refer to Appendix (Internal Photos)

6.2 Conducted Emissions at AC Power Line (150kHz-30MHz)

Test Requirement 47 CFR Part 15, Subpart C 15.207
Test Method: ANSI C63.10 (2013) Section 6.2
Limit:

Frequency of emission(MHz)	Conducted limit(dBμV)	
	Quasi-peak	Average
0.15-0.5	66 to 56*	56 to 46*
0.5-5	56	46
5-30	60	50

*Decreases with the logarithm of the frequency.

6.2.1 E.U.T. Operation

Operating Environment:

Temperature: 22 °C Humidity: 50 % RH Atmospheric Pressure: 1020 mbar
Test mode a: TX mode_Keep the EUT in transmitting with modulation mode.

6.2.2 Test Setup Diagram

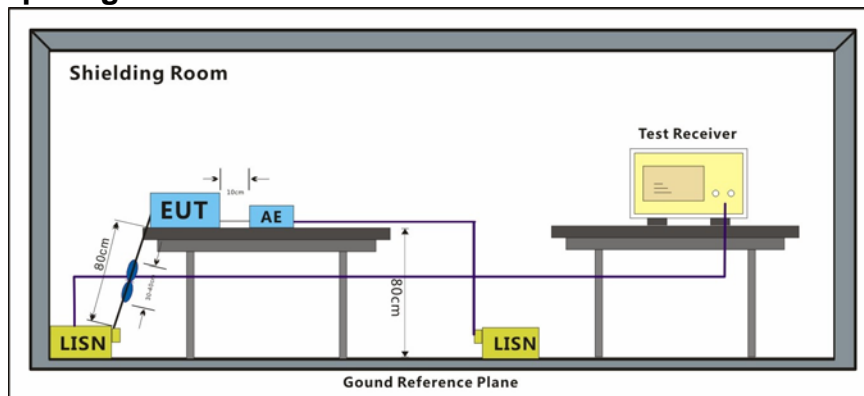

6.2.3 Measurement Procedure and Data

- 1) The mains terminal disturbance voltage test was conducted in a shielded room.
 - 2) The EUT was connected to AC power source through a LISN 1 (Line Impedance Stabilization Network) which provides a 50ohm/50μH + 5ohm linear impedance. The power cables of all other units of the EUT were connected to a second LISN 2, which was bonded to the ground reference plane in the same way as the LISN 1 for the unit being measured. A multiple socket outlet strip was used to connect multiple power cables to a single LISN provided the rating of the LISN was not exceeded.
 - 3) The tabletop EUT was placed upon a non-metallic table 0.8m above the ground reference plane. And for floor-standing arrangement, the EUT was placed on the horizontal ground reference plane,
 - 4) The test was performed with a vertical ground reference plane. The rear of the EUT shall be 0.4 m from the vertical ground reference plane. The vertical ground reference plane was bonded to the horizontal ground reference plane. The LISN 1 was placed 0.8 m from the boundary of the unit under test and bonded to a ground reference plane for LISNs mounted on top of the ground reference plane. This distance was between the closest points of the LISN 1 and the EUT. All other units of the EUT and associated equipment was at least 0.8 m from the LISN 2.
 - 5) In order to find the maximum emission, the relative positions of equipment and all of the interface cables must be changed according to ANSI C63.10 on conducted measurement.
- This EUT is powered by battery only; therefore the AC Conducted Emission test is not applicable.

6.3 Spurious Emissions

Test frequency range: 9KHz – 5GHz

Test Site: Measurement Distance: 3m

Receiver Setup:

Frequency	Detector	RBW	VBW	Remark
0.009MHz-0.015MHz	Quasi-peak	200Hz	1KHz	Quasi-peak
0.015MHz-30MHz	Quasi-peak	9kHz	30KHz	Quasi-peak
30MHz-1GHz	Quasi-peak	120 kHz	300KHz	Quasi-peak
Above 1GHz	Peak	1MHz	3MHz	Peak
	Peak	1MHz	10Hz	Average

**Limit:
(Spurious Emissions)**

Frequency	Field strength (microvolt/meter)	Limit (dBuV/m)	Remark	Measurement distance (m)
0.009MHz-0.490MHz	2400/F(kHz)	-	Quasi-peak	300
0.490MHz-1.705MHz	24000/F(kHz)	-	Quasi-peak	30
1.705MHz-30MHz	30	-	Quasi-peak	30
30MHz-88MHz	100	40.0	Quasi-peak	3
88MHz-216MHz	150	43.5	Quasi-peak	3
216MHz-960MHz	200	46.0	Quasi-peak	3
960MHz-1GHz	500	54.0	Quasi-peak	3
Above 1GHz	500	54.0	Average	3
		74.0	Peak	3

**Limit:
(Field strength of the fundamental signal)**

Frequency	Limit (dBuV/m @3m)	Remark
433.09 - 434.61MHz	80.83	Average Value
	100.83	Peak Value

Test Procedure:

- The EUT was placed on the top of a rotating table 0.8 meters above the ground at a 3 meter semi-anechoic chamber. The table was rotated 360 degrees to determine the position of the highest radiation.
- The EUT was set 3 meters away from the interference-receiving antenna, which was mounted on the top of a variable-height antenna tower.
- The antenna height is varied from one meter to four meters above the ground to determine the maximum value of the field strength. Both horizontal and vertical polarizations of the antenna are set to make the measurement.
- For each suspected emission, the EUT was arranged to its worst case and then the antenna was tuned to heights from 1 meter to 4 meters (for the test frequency of below 30MHz, the antenna was tuned to heights 1 meter) and the rotatable table was turned from 0 degrees to 360 degrees to find the maximum reading.
- The test-receiver system was set to Peak Detect Function and Specified Bandwidth with Maximum Hold Mode.
- If the emission level of the EUT in peak mode was 10dB lower than the limit specified, then testing could be stopped and the peak values of the EUT would be reported. Otherwise the emissions that did not have 10dB margin would be re-tested one by one using peak, quasi-peak or average method as specified and then reported in a data sheet.
- The radiation measurements are performed in X, Y, Z axis positioning. And found the Z axis positioning which it is worse case, only the test worst case mode is recorded in the report.

E.U.T. Operation

Operating Environment:

Temperature: 22 °C Humidity: 50 % RH Atmospheric Pressure: 1020 mbar
Test mode a: TX mode_Keep the EUT in transmitting with modulation mode.

Test Setup:

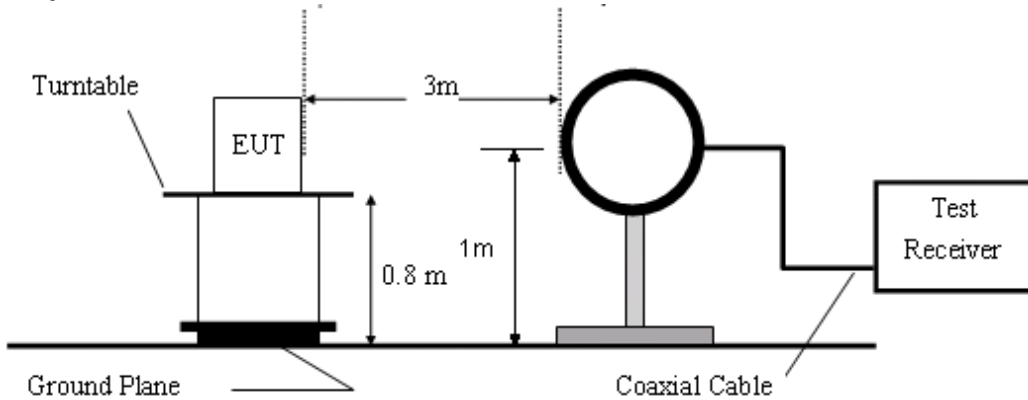

Figure1. Blow 30MHz radiated emissions test configuration

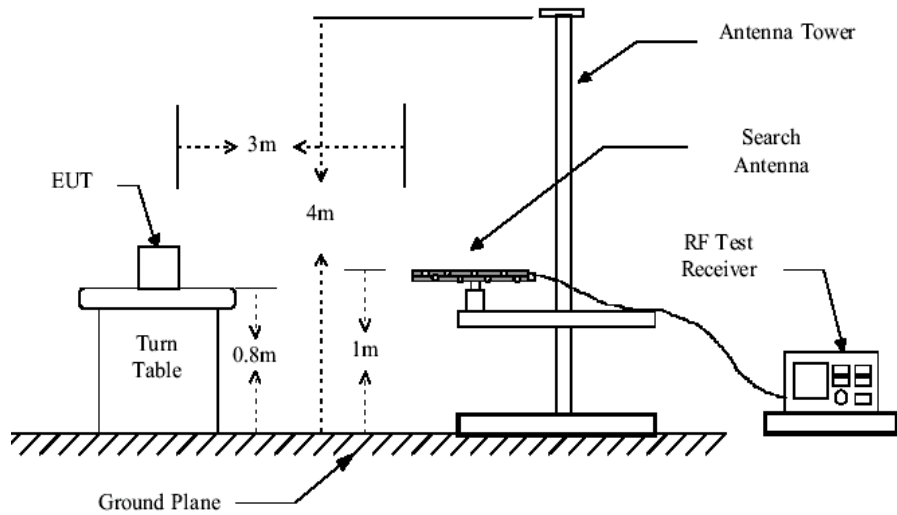

Figure2. 30MHz to 1GHz radiated emissions test configuration

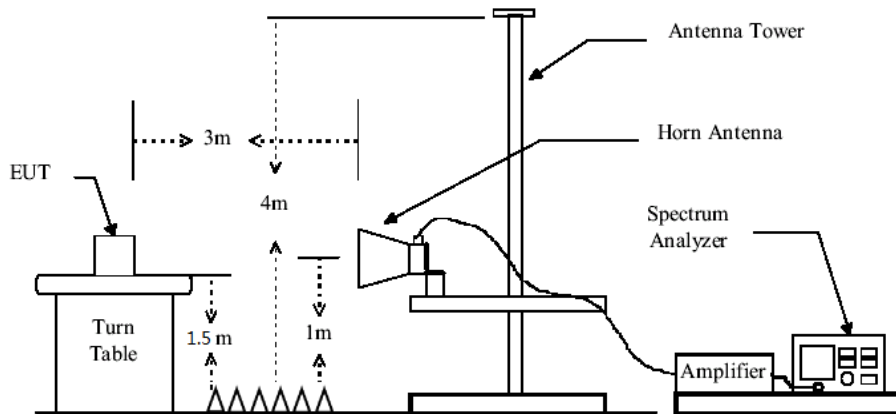

Figure3. Above 1GHz radiated emissions test configuration

Test Results: Pass



6.3.1 Field Strength of the Fundamental Signal

Test channel	Freq. (MHz)	Result Level (dB μ V/m)	Limit Line (dB μ V/m)	Over Limit (dB)	Detector	Polarization
Channel 1	433.10	59.84	80.83	-20.99	Peak	Vertical
		76.13	80.83	-4.7	Peak	Horizontal

Remark: If the Peak value below the AV Limit, the AV test doesn't perform for this submission.

6.3.2 Spurious Emissions

Below 1GHz

Vertical:

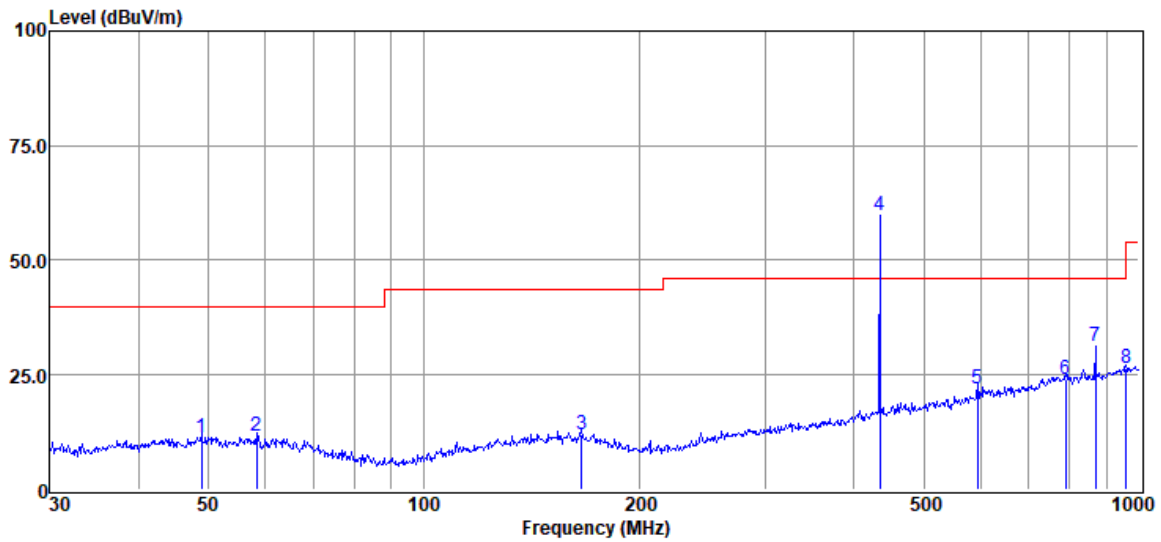

Item	Freq.	Read Level	Antenna Factor	Preamp Factor	Cable Loss	Result Level	Limit Line	Over Limit	Detector
(Mark)	(MHz)	(dBμV)	(dB/m)	(dB)	(dB)	(dBμV/m)	(dBμV/m)	(dB)	
1	48.843	38.93	13.65	42.33	1.03	11.28	40.00	-28.72	QP
2	58.407	39.57	13.19	42.33	1.10	11.53	40.00	-28.47	QP
3	166.068	39.51	12.96	42.21	1.81	12.07	43.50	-31.43	QP
4	434.065	82.38	16.52	41.81	2.75	59.84	80.83	-20.99	Peak
5	595.133	41.00	19.49	41.67	3.18	22.00	46.00	-24.00	QP
6	790.619	40.05	22.27	41.99	3.69	24.02	46.00	-21.98	QP
7	869.130	46.30	22.90	41.74	3.86	31.32	60.83	-29.51	QP
8	958.794	39.66	24.00	41.38	4.02	26.30	46.00	-19.70	QP

Horizontal:

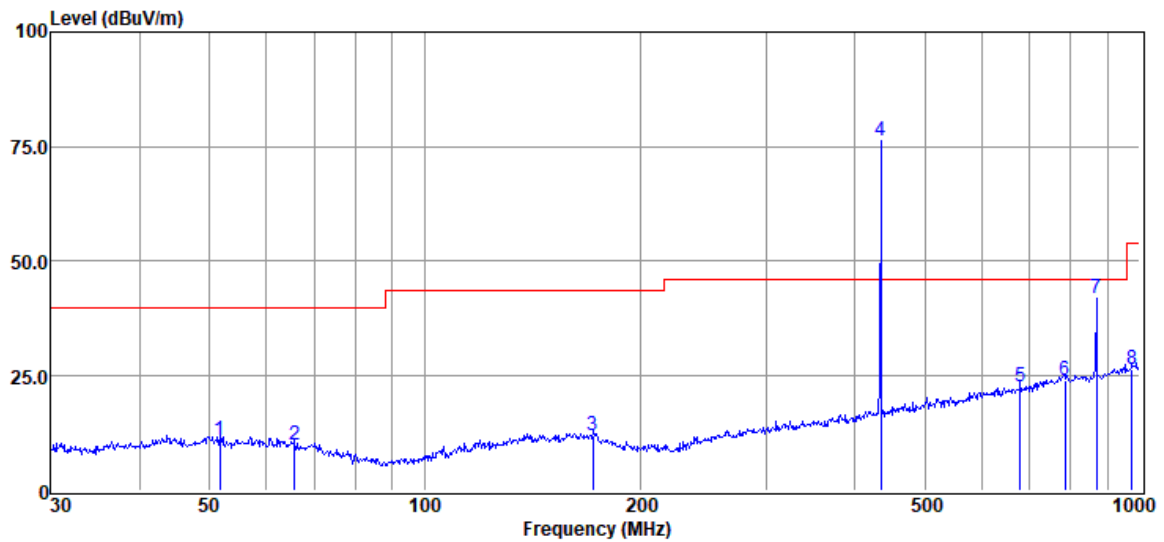

Item	Freq.	Read Level	Antenna Factor	Preamp Factor	Cable Loss	Result Level	Limit Line	Over Limit	Detector
(Mark)	(MHz)	(dB μ V)	(dB/m)	(dB)	(dB)	(dB μ V/m)	(dB μ V/m)	(dB)	
1	51.662	38.58	13.60	42.33	1.06	10.91	40.00	-29.09	QP
2	65.803	38.77	12.27	42.29	1.15	9.90	40.00	-30.10	QP
3	171.995	39.82	12.61	42.21	1.84	12.06	43.50	-31.44	QP
4	434.065	98.67	16.52	41.81	2.75	76.13	80.83	-4.70	Peak
5	679.960	40.36	20.61	41.76	3.43	22.64	46.00	-23.36	QP
6	785.093	40.17	22.24	41.99	3.67	24.09	46.00	-21.91	QP
7	869.130	57.06	22.90	41.74	3.86	42.08	60.83	-18.75	QP
8	975.753	39.65	24.00	41.17	4.06	26.54	54.00	-27.46	QP



Above 1GHz

Mark	Frequency (MHz)	Reading (dBuV)	Factor (dB)	Emission (dBuV/m)	Limit (dBuV/m)	Over Limit (dB)	Detector	polarization
1	1883.289	58.21	24.94	48.7	74	-25.3	peak	Vertical
2	3987.219	48.3	29.86	44.33	74	-29.67	peak	Vertical
3	4773.12	49.21	30.79	46.56	74	-27.44	peak	Vertical
4	1778.21	53.29	24.5	43.28	74	-30.72	peak	Horizontal
5	2579.12	51.19	26.42	43.15	74	-30.85	peak	Horizontal
6	4997.21	51.1	31.4	49.45	74	-24.55	peak	Horizontal

Remark:

- 1) The field strength is calculated by adding the Antenna Factor, Cable Factor & Preamplifier. The basic equation with a sample calculation is as follows:
Final Test Level = Receiver Reading Level + Antenna Factor + Cable Factor – Preamplifier Factor
- 2) If Peak Result comply with AV limit, AV Result is deemed to comply with QP limit
- 3) No any other emissions level which are attenuated less than 20dB below the limit. According to 15.31(o), the amplitude of spurious emissions from intentional radiators and emissions from unintentional radiators which are attenuated more than 20 dB below the permissible value need not be reported unless specifically required elsewhere in this Part. Hence there no other emissions have been reported.

6.4 20dB Bandwidth

E.U.T. Operation

Operating Environment:

Temperature: 22 °C Humidity: 50 % RH Atmospheric Pressure: 1020 mbar

Test mode a: TX mode_Keep the EUT in transmitting with modulation mode.

Test Setup:

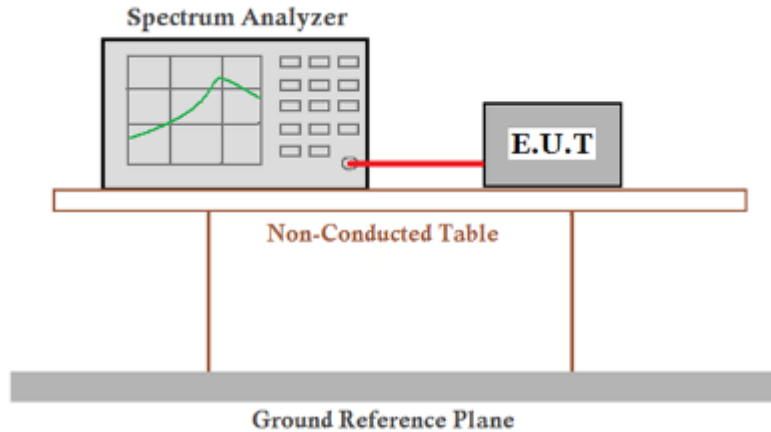

Limit:

The bandwidth of the emission shall be no wider than 0.25% of the center frequency for devices operating above 70 MHz and below 900 MHz. For devices operating above 900 MHz, the emission shall be no wider than 0.5% of the center frequency. Bandwidth is determined at the points 20 dB down from the modulated carrier.

Test Results:

Pass

Measurement Data:

Frequency(MHz)	20dB bandwidth (kHz)	Limit (kHz)	Results
433.1	90	1084.8	Pass

Test plot as follows:

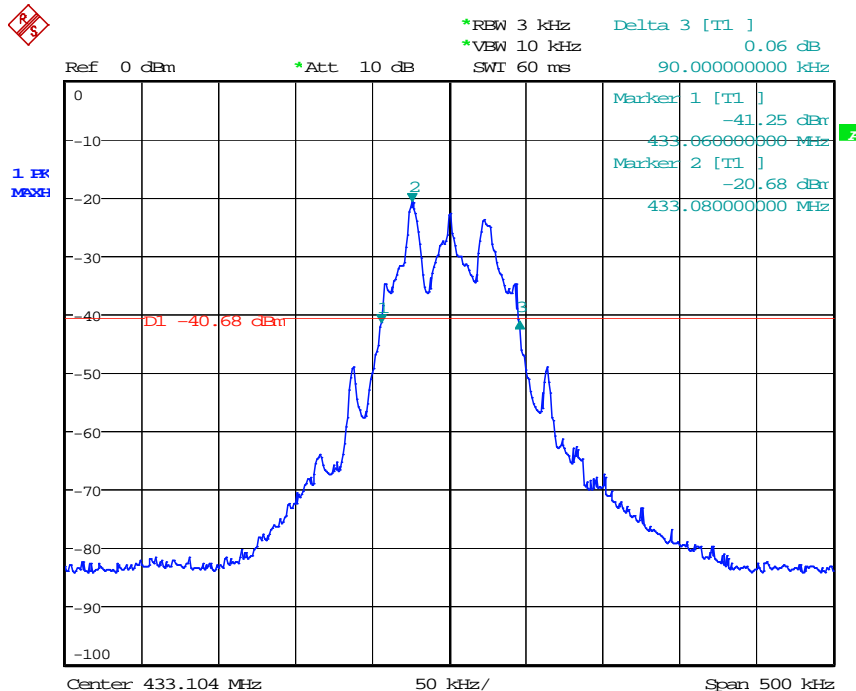

6.5 Dwell Time

E.U.T. Operation

Operating Environment:

Temperature: 22 °C Humidity: 50 % RH Atmospheric Pressure: 1020 mbar

Test mode a: TX mode_Keep the EUT in transmitting with modulation mode.

Test Setup:

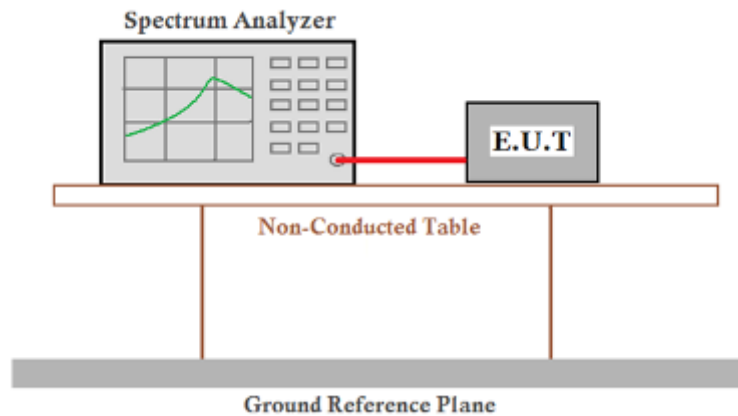

Limit: 15.231 (a): Not more than 5 seconds

Test Results: Pass

Measurement Data:

Test item	Limit (s)	Results
Transmission Duration	≤5s	Pass



Test plot as follows:

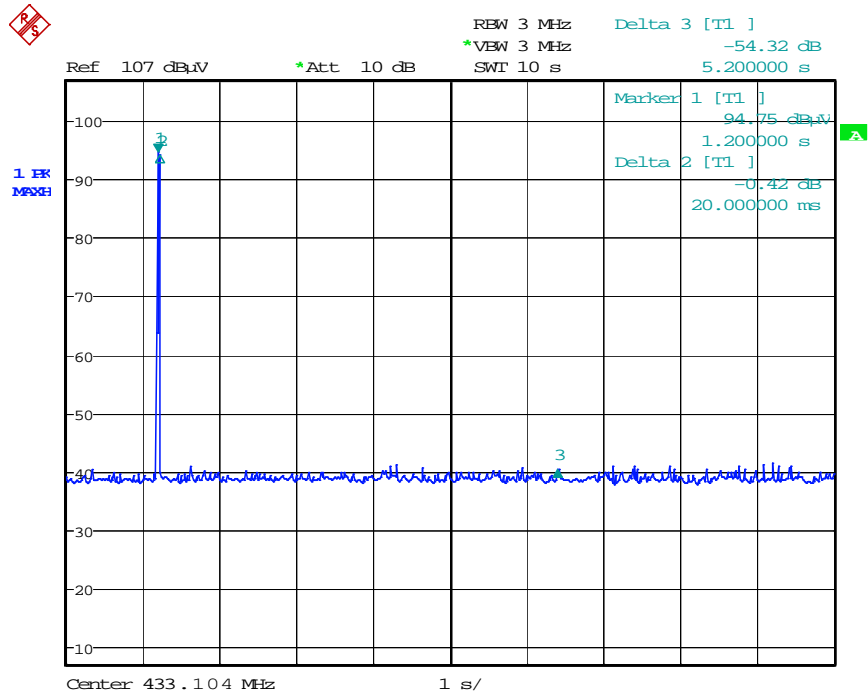



7 Test Setup Photographs

Refer to the < Test Setup photos-FCC >.

8 EUT Constructional Details

Refer to the < External Photos > & < Internal Photos >.

--End of the Report--