



MEASUREMENT REPORT

FCC PART 15.231

FCC ID: 2ADTD-D0710031

Applicant: Hangzhou Hikvision Digital Technology Co., Ltd

Application Type: Certification

Product: Wireless Dual-Tech AM Curtain Detector

Model No.: DS-PDC10DM-EG2-WB

Brand Name: HIKVISION

FCC Classification: Part 15 Remote Control/Security Device Transceiver (DSR)

FCC Rule Part(s): Part 15.231

Test Procedure(s): ANSI C63.10-2013

Test Date: July 21 ~ 25, 2021

Reviewed By:

Kevin Guo

Kevin Guo

Approved By:

Robin Wu

Robin Wu



The test results relate only to the samples tested.

This equipment has been shown to be capable of compliance with the applicable technical standards as indicated in the measurement report and was tested in accordance with the measurement procedures specified in ANSI C63.10-2013. Test results reported herein relate only to the item(s) tested.

The test report shall not be reproduced except in full without the written approval of MRT Technology (Suzhou) Co., Ltd.

Revision History

Report No.	Version	Description	Issue Date	Note
2104RSU070-U1	Rev. 01	Initial Report	08-06-2021	Valid

CONTENTS

Description	Page
1. GENERAL INFORMATION	5
1.1. Applicant	5
1.2. Manufacturer	5
1.3. Testing Facility	5
1.4. Product Information	6
1.5. Radio Specification	6
1.6. Working Frequencies	6
1.7. Test Mode	6
1.8. Test System Connection Diagram	7
1.9. Description of Test Software	7
1.10. Test Environment Condition	7
2. ANTENNA REQUIREMENTS	8
3. TEST EQUIPMENT CALIBRATION DATE	9
4. MEASUREMENT UNCERTAINTY	11
5. TEST RESULT	12
5.1. Summary	12
5.2. Conducted Emission	13
5.2.1. Test Limit	13
5.2.2. Test Setup	13
5.2.3. Test Result	13
5.3. Radiated Emissions	14
5.3.1. Test Limit	14
5.3.2. Test Procedure Used	15
5.3.3. Test Setting	16
5.3.4. Test Setup	17
5.3.5. Test Results	19
5.4. 20dB Bandwidth	22
5.4.1. Test Limit	22
5.4.2. Test Procedure used	22
5.4.3. Test Setting	22
5.4.4. Test Setup	22
5.4.5. Test Result	23
5.5. Transmission Time	24
5.5.1. Test Limit	24
5.5.2. Test Procedure	24
5.5.3. Test Setting	24
5.5.4. Test Setup	25

5.5.5. Test Result.....	26
6. CONCLUSION.....	27
Appendix A - Test Setup Photograph	28
Appendix B - EUT Photograph.....	29

1. GENERAL INFORMATION

1.1. Applicant

Hangzhou Hikvision Digital Technology Co., Ltd
 No.555 Qianmo Road, Binjiang District, Hangzhou 310052, China

1.2. Manufacturer

Hangzhou Hikvision Digital Technology Co., Ltd
 No.555 Qianmo Road, Binjiang District, Hangzhou 310052, China

1.3. Testing Facility

<input checked="" type="checkbox"/>	Test Site – MRT Suzhou Laboratory Laboratory Location (Suzhou - Wuzhong) D8 Building, No.2 Tian'edang Rd., Wuzhong Economic Development Zone, Suzhou, China Laboratory Location (Suzhou - SIP) 4b Building, Liando U Valley, No.200 Xingpu Rd., Shengpu Town, Suzhou Industrial Park, China Laboratory Accreditations A2LA: 3628.01 CNAS: L10551 FCC: CN1166 ISED: CN0001 VCCI: R-20025, G-20034, C-20020, T-20020
<input type="checkbox"/>	Test Site – MRT Shenzhen Laboratory Laboratory Location (Shenzhen) 1G, Building A, Junxiangda Building, Zhongshanyuan Road West, Nanshan District, Shenzhen, China Laboratory Accreditations A2LA: 3628.02 CNAS: L10551 FCC: CN1284 ISED: CN0105
<input type="checkbox"/>	Test Site – MRT Taiwan Laboratory Laboratory Location (Taiwan) No. 38, Fuxing 2nd Rd., Guishan Dist., Taoyuan City 333, Taiwan (R.O.C.) Laboratory Accreditations TAF: L3261-190725 FCC: 291082, TW3261 ISED: TW3261

1.4. Product Information

Product Name	Wireless Dual-Tech AM Curtain Detector
Model No.	DS-PDC10DM-EG2-WB
Serial Model No.:	DS-PDC10DM-EG2-WBUHK, DS-PDC10DM-EG2-WBCKV, DS-PDC10DM-EG2-WBUVS, DS-PDC10DM-EG2-WBKVO, DS-PDC10DM-EG2-WBHUN
SRD RF Specification	433.1MHz~433.7MHz
Radar Specification	24GHz (Integration 24G Hz microwave module)
Operating Voltage	3Vdc (By internal battery)
Remark:	
<ol style="list-style-type: none"> The model differences are only for marketing purpose, all the schematics are identical, so choose model DS-PDC10DM-EG2-WB test. The information of EUT was provided by the manufacturer, and the accuracy of the information shall be the responsibility of the manufacturer. 	

1.5. Radio Specification

Frequency Range	433.1MHz~433.7MHz
Channel Bandwidth	100KHz
Channel Number	7
Type of Modulation	FSK
Antenna Type	Monopole
Antenna Gain	-8dBi

1.6. Working Frequencies

Channel	Frequency	Channel	Frequency	Channel	Frequency
01	433.1 MHz	02	433.2 MHz	03	433.3 MHz
04	433.4 MHz	05	433.5 MHz	06	433.6 MHz
07	433.7 MHz	--	--	--	--

1.7. Test Mode

Test Mode	Mode 1: Transmit at 433.7MHz
-----------	------------------------------

1.8. Test System Connection Diagram

ANSI C63.10-2013 was used to reference the appropriate EUT setup for test.

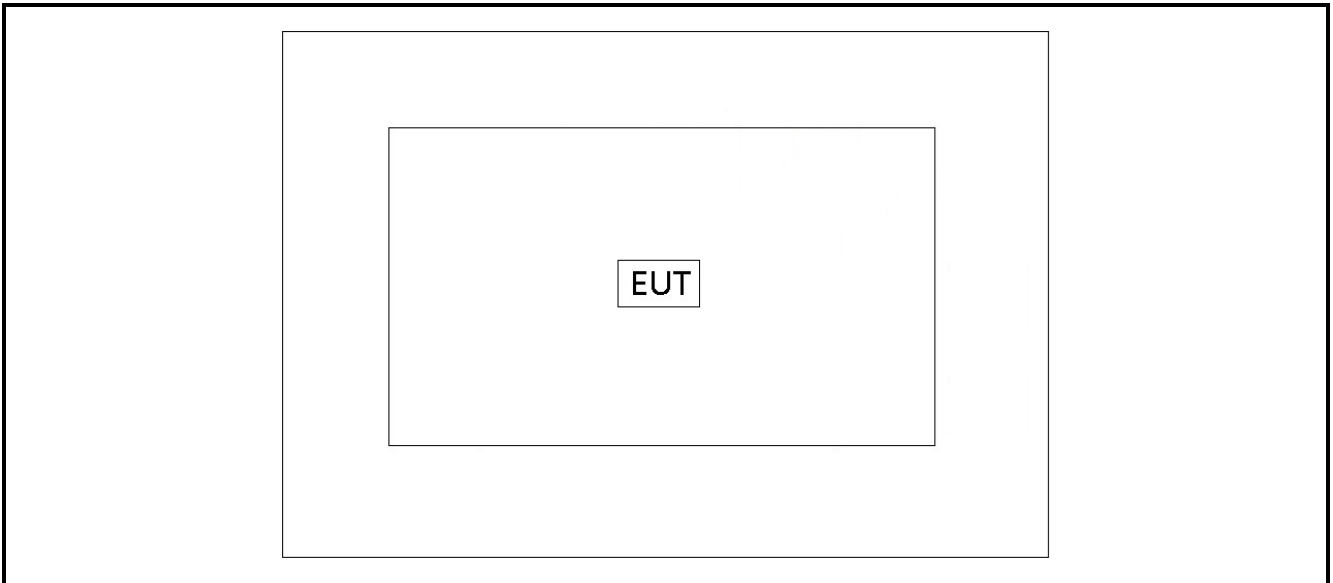

1.9. Description of Test Software

The sample provided by the manufacturer is always in the transmitting state after power-on.

1.10. Test Environment Condition

Ambient Temperature	15°C ~ 35°C
Relative Humidity	20%RH ~ 75%RH

2. ANTENNA REQUIREMENTS

Excerpt from §15.203 of the FCC Rules/Regulations:

“An intentional radiator antenna shall be designed to ensure that no antenna other than that furnished by the responsible party can be used with the device. The use of a permanently attached antenna or of an antenna that uses a unique coupling to the intentional radiator shall be considered sufficient to comply with the provisions of this section.”

- The antenna of the device is **permanently attached**.
- There are no provisions for connection to an external antenna.

Conclusion:

The unit complies with the requirement of §15.203.

3. TEST EQUIPMENT CALIBRATION DATE

Radiated Emission (WZ-AC1)

Instrument	Manufacturer	Type No.	Asset No.	Cali. Interval	Cali. Due Date
EMI Test Receiver	R&S	ESR7	MRTSUE06001	1 year	2022/01/04
PXA Signal Analyzer	Keysight	N9030B	MRTSUE06395	1 year	2021/08/30
Loop Antenna	Schwarzbeck	FMZB 1519	MRTSUE06025	1 year	2021/11/08
Bilog Period Antenna	Schwarzbeck	VULB 9168	MRTSUE06172	1 year	2021/08/08
Horn Antenna	Schwarzbeck	BBHA 9120D	MRTSUE06023	1 year	2021/09/27
Horn Antenna	Schwarzbeck	BBHA9170	MRTSUE06597	1 year	2021/12/14
Microwave System Amplifier	Agilent	83017A	MRTSUE06076	1 year	2021/11/14
Preamplifier	Schwarzbeck	BBV 9721	MRTSUE06121	1 year	2022/06/10
Thermal Hygrometer	testo	608-H1	MRTSUE06403	1 year	2021/07/26
Anechoic Chamber	TDK	Chamber-AC1	MRTSUE06212	1 year	2022/04/29

Radiated Emission (WZ-AC2)

Instrument	Manufacturer	Type No.	Asset No.	Cali. Interval	Cali. Due Date
MXE EMI Receiver	Keysight	N9038A	MRTSUE06125	1 year	2022/06/24
Loop Antenna	Schwarzbeck	FMZB 1519	MRTSUE06025	1 year	2021/11/08
Bilog Period Antenna	Schwarzbeck	VULB 9162	MRTSUE06022	1 year	2022/05/24
Broad-Band Horn Antenna	Schwarzbeck	BBHA 9120D	MRTSUE06171	1 year	2021/10/25
Horn Antenna	Schwarzbeck	BBHA9170	MRTSUE06597	1 year	2021/12/14
Broadband Coaxial Preamplifier	Schwarzbeck	BBV 9718	MRTSUE06176	1 year	2021/11/14
Preamplifier	Schwarzbeck	BBV 9721	MRTSUE06121	1 year	2022/06/08
Thermal Hygrometer	Minggao	ETH529	MRTSUE06170	1 year	2021/12/08
Anechoic Chamber	RIKEN	Chamber-AC2	MRTSUE06213	1 year	2022/04/29

Radiated Emission (SIP-AC1)

Instrument	Manufacturer	Type No.	Asset No.	Cali. Interval	Cali. Due Date
EMI Test Receiver	R&S	ESR3	MRTSUE06612	1 year	2022/06/24
EXA Signal Analyzer	Keysight	N9010B	MRTSUE06559	1 year	2022/06/24
Loop Antenna	Schwarzbeck	FMZB 1519	MRTSUE06025	1 year	2021/11/08
Bilog Period Antenna	Schwarzbeck	VULB9168	MRTSUE06645	1 year	2021/08/30
Double Ridged Horn Antenna	R&S	HF907	MRTSUE06610	1 year	2021/08/30
Preamplifier	EMCI	EMC051845SE	MRTSUE06600	1 year	2021/11/12
Thermal Hygrometer	testo	608-H1	MRTSUE06620	1 year	2021/12/03
Anechoic Chamber	RIKEN	SIP-AC1	MRTSUE06554	1 year	2021/12/24

Radiated Emission (SIP-AC2)

Instrument	Manufacturer	Type No.	Asset No.	Cali. Interval	Cali. Due Date
EMI Test Receiver	R&S	ESR3	MRTSUE06613	1 year	2022/06/24
MXA Signal Analyzer	Keysight	N9020B	MRTSUE06604	1 year	2021/09/26
Loop Antenna	Schwarzbeck	FMZB 1519	MRTSUE06025	1 year	2021/11/08
Bilog Period Antenna	Schwarzbeck	VULB9168	MRTSUE06646	1 year	2021/08/30
Horn Antenna	Schwarzbeck	BBHA9120D	MRTSUE06648	1 year	2021/11/26
Horn Antenna	Schwarzbeck	BBHA9170	MRTSUE06599	1 year	2021/11/26
Preamplifier	EMCI	EMC051845SE	MRTSUE06644	1 year	2021/11/12
Preamplifier	EMCI	EMC184045SE	MRTSUE06602	1 year	2021/10/13
Thermal Hygrometer	testo	608-H1	MRTSUE06624	1 year	2021/12/03
Anechoic Chamber	RIKEN	SIP-AC2	MRTSUE06781	1 year	2021/12/24

Radiated Emission (SIP-AC3)

Instrument	Manufacturer	Type No.	Asset No.	Cali. Interval	Cali. Due Date
EMI Test Receiver	R&S	ESR3	MRTSUE06612	1 year	2022/06/24
EXA Signal Analyzer	Keysight	N9010B	MRTSUE06559	1 year	2022/06/24
Loop Antenna	Schwarzbeck	FMZB 1519	MRTSUE06025	1 year	2021/11/08
Bilog Period Antenna	Schwarzbeck	VULB9168	MRTSUE06647	1 year	2021/08/08
Double Ridged Horn Antenna	R&S	HF907	MRTSUE06611	1 year	2021/09/13
Horn Antenna	Schwarzbeck	BBHA9170	MRTSUE06598	1 year	2021/11/26
Preamplifier	EMCI	EMC012645SE	MRTSUE06642	1 year	2022/01/14
Preamplifier	EMCI	EMC184045SE	MRTSUE06641	1 year	2022/01/14
Thermal Hygrometer	testo	608-H1	MRTSUE06622	1 year	2021/12/03
Anechoic Chamber	RIKEN	SIP-AC3	MRTSUE06782	1 year	2021/12/24

Software	Version	Function
EMI Software	V3	EMI Test Software

4. MEASUREMENT UNCERTAINTY

Where relevant, the following test uncertainty levels have been estimated for tests performed on the EUT as specified in CISPR 16-4-2. This uncertainty represents an expanded uncertainty expressed at approximately the 95% confidence level using a coverage factor of $k = 2$.

Conducted Emission Measurement
The maximum measurement uncertainty is evaluated as: 9kHz~150kHz: 3.74dB 150kHz~30MHz: 3.44dB
Radiated Emission Measurement
The maximum measurement uncertainty is evaluated as: Horizontal: 30MHz~300MHz: 5.04dB 300MHz~1GHz: 4.95dB 1GHz~40GHz: 6.40dB Vertical: 30MHz~300MHz: 5.24dB 300MHz~1GHz: 6.03dB 1GHz~40GHz: 6.40dB

5. TEST RESULT

5.1. Summary

FCC Part Section(s)	Test Description	Test Condition	Test Result	Reference
15.207	AC Conducted Emissions 150kHz - 30MHz	Line Conducted	N/A	Section 5.2
15.205, 15.231(b)	Radiated Spurious Emissions	Radiated	Pass	Section 5.3
15.231(c)	20dB Bandwidth		Pass	Section 5.4
15.231(a)(3)	Transmission Time		Pass	Section 5.5

Notes:

- 1) The test results shown in the following sections represent the worst-case emissions.
- 2) "N/A" means that the test item is not applicable, and the detailed information refers to relevant section.

5.2. Conducted Emission

5.2.1. Test Limit

FCC Part 15.207 & RSS-Gen Limits		
Frequency (MHz)	QP (dB μ V)	AV (dB μ V)
0.15 ~ 0.50	66 ~ 56	56 ~ 46
0.50 ~ 5.0	56	46
5.0 ~ 30	60	50

Note 1: The lower limit shall apply at the transition frequencies.

Note 2: The limit decreases linearly with the logarithm of the frequency in the range 0.15MHz to 0.5MHz.

5.2.2. Test Setup

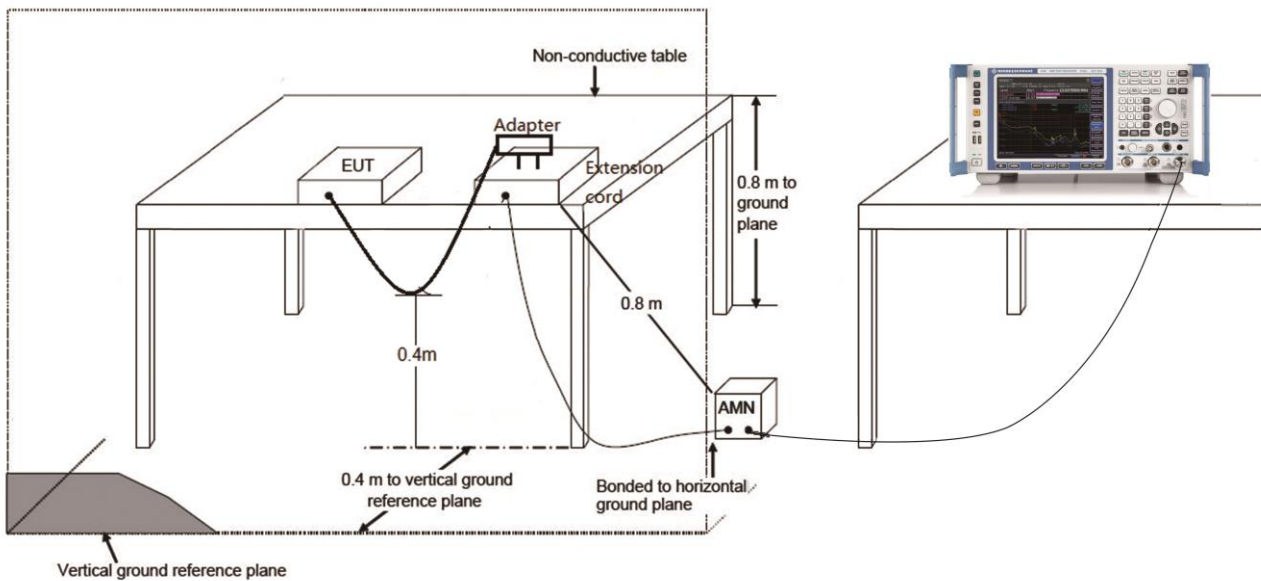

5.2.3. Test Result

This device is powered by internal battery, so this requirement is not applicable.

5.3. Radiated Emissions

5.3.1. Test Limit

According to §15.231(b), the field strength of emissions from intentional radiators operated under this section shall not exceed the following:

FCC Part 15.231(b) Limits		
Fundamental Frequency (MHz)	Field strength of fundamental (microvolts/meter)	Field strength of spurious emission (microvolts/meter)
40.66 - 40.77	2250	225
70 - 130	1250	125
130 - 174	1250 to 3750	125 to 375
174 - 260	3750	375
260 - 470	3750 to 12500	375 to 1250
Above 470	12500	1250

Note 1: The above field strength limits are specified at a distance of 3 meters. The tighter limits apply at the band edges.

Note 2: Intentional radiators operating under the provisions of this section shall demonstrate compliance with the limits on the field strength of emissions, as shown in the above table, based on the average value of the measured emissions. As an alternative, compliance with the limits in the above table may be based on the use of measurement instrumentation with a CISPR quasi-peak detector.

FCC Part 15 Subpart C Paragraph 15.209		
Frequency [MHz]	Field Strength [$\mu\text{V}/\text{m}$]	Measured Distance [Meters]
0.009 - 0.490	2400/F (kHz)	300
0.490 - 1.705	24000/F (kHz)	30
1.705 - 30	30	30
30 - 88	100	3
88 - 216	150	3
216 - 960	200	3
Above 960	500	3

For 15.205 requirement:

Radiated emissions which fall in the restricted bands, as defined in Section 15.205(a) of FCC part 15, must also comply with the radiated emission limits specified in Section 15.209(a).

Frequency (MHz)	Frequency (MHz)	Frequency (MHz)	Frequency (GHz)
0.090 - 0.110	16.42 - 16.423	399.9 - 410	4.5 - 5.15
0.495 - 0.505	16.69475 - 16.69525	608 - 614	5.35 - 5.46
2.1735 - 2.1905	16.80425 - 16.80475	960 - 1240	7.25 - 7.75
4.125 - 4.128	25.5 - 25.67	1300 - 1427	8.025 - 8.5
4.17725 - 4.17775	37.5 - 38.25	1435 - 1626.5	9.0 - 9.2
4.20725 - 4.20775	73 - 74.6	1645.5 - 1646.5	9.3 - 9.5
6.215 - 6.218	74.8 - 75.2	1660 - 1710	10.6 - 12.7
6.26775 - 6.26825	108 - 121.94	1718.8 - 1722.2	13.25 - 13.4
6.31175 - 6.31225	123 - 138	2200 - 2300	14.47 - 14.5
8.291 - 8.294	149.9 - 150.05	2310 - 2390	15.35 - 16.2
8.362 - 8.366	156.52475 - 156.52525	2483.5 - 2500	17.7 - 21.4
8.37625 - 8.38675	156.7 - 156.9	2690 - 2900	22.01 - 23.12
8.41425 - 8.41475	162.0125 - 167.17	3260 - 3267	23.6 - 24.0
12.29 - 12.293	167.72 - 173.2	3332 - 3339	31.2 - 31.8
12.51975 - 12.52025	240 - 285	3345.8 - 3358	36.43 - 36.5
12.57675 - 12.57725	322 - 335.4	3600 - 4400	--
13.36 - 13.41	--	--	--

5.3.2. Test Procedure Used

ANSI C63.10-2013 Section 6.3 (General Requirements)

ANSI C63.10-2013 Section 6.4 (Radiated emissions below 30 MHz)

ANSI C63.10-2013 Section 6.5 (Radiated emissions above 30 MHz and below 1000 MHz)

ANSI C63.10-2013 Section 6.6 (Radiated emissions above 1000 MHz)

ANSI C63.10-2013 Section 7.5 (Procedure for determining the average value of pulsed emissions)

5.3.3. Test Setting

Table 1 - RBW as a function of frequency

Frequency	RBW
9 ~ 150 kHz	200 Hz
0.15 ~ 30 MHz	9 kHz
30 ~ 1000 MHz	120 kHz
> 1000 MHz	1 MHz

Quasi-Peak Measurements below 1GHz

1. Analyzer center frequency was set to the frequency of the radiated spurious emission of interest
2. RBW = as specified in Table 1
3. Detector = CISPR quasi-peak (a linear average detector for 9-90 kHz and 110-490 kHz)
4. Sweep time = auto couple
5. Trace was allowed to stabilize

Peak Measurements above 1GHz

1. Analyzer center frequency was set to the frequency of the radiated spurious emission of interest
2. RBW = 1MHz
3. VBW = 3MHz
4. Detector = peak
5. Sweep time = auto couple
6. Trace mode = max hold
7. Trace was allowed to stabilize

Average Measurement of pulsed emissions

1. Make EUT is transmitting to obtain the “worst-case” pulse ON time.
2. Couple the final radio frequency output signal to the input of a spectrum analyzer.
3. Adjust the center frequency of the spectrum analyzer to the center of the RF signal.
4. Set the spectrum analyzer for ZERO SPAN.

5. Sweep time = 100ms
6. Set the TRIGGER on the spectrum analyzer to capture at least one period of the pulse train, including any blanking intervals.
7. Determine the total maximum pulse “ON time” (t_{ON}) over one period of the pulse train.
8. The duty cycle is then determined by dividing the total maximum “ON time” by the period of the pulse train ($t_{ON}/100\text{ms}$).
9. Determine the duty cycle correction factor. Duty Cycle Factor = $20 \cdot \text{Log}(\text{Duty Cycle})$
10. This correction factor may then be subtracted from the peak pulse amplitude (in dB) to find the average emission.

5.3.4. Test Setup

Below 30MHz Test Setup:

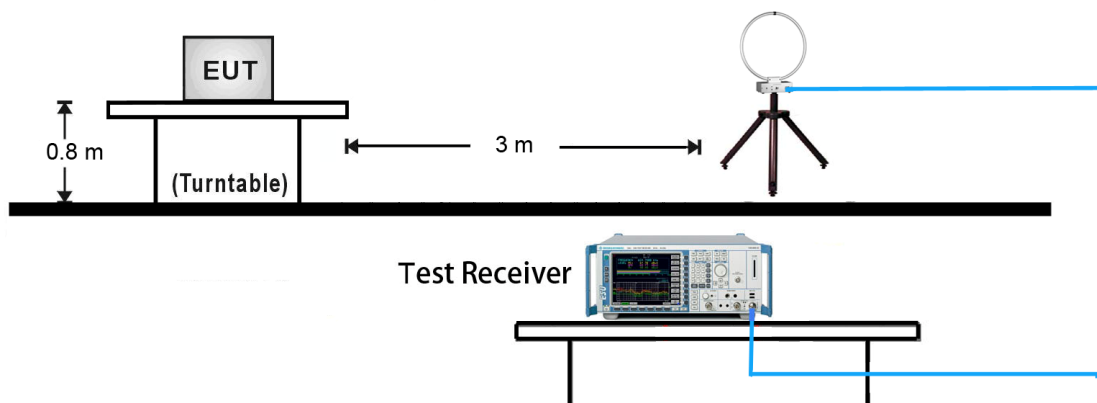

30MHz ~ 1GHz Test Setup:

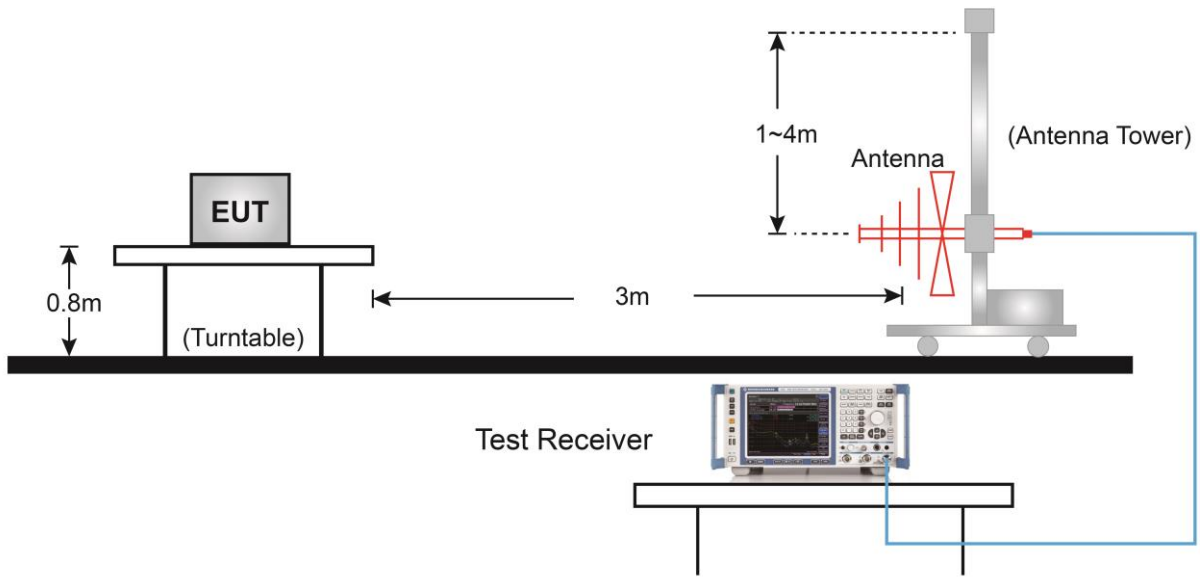

Above 1GHz Test Setup:

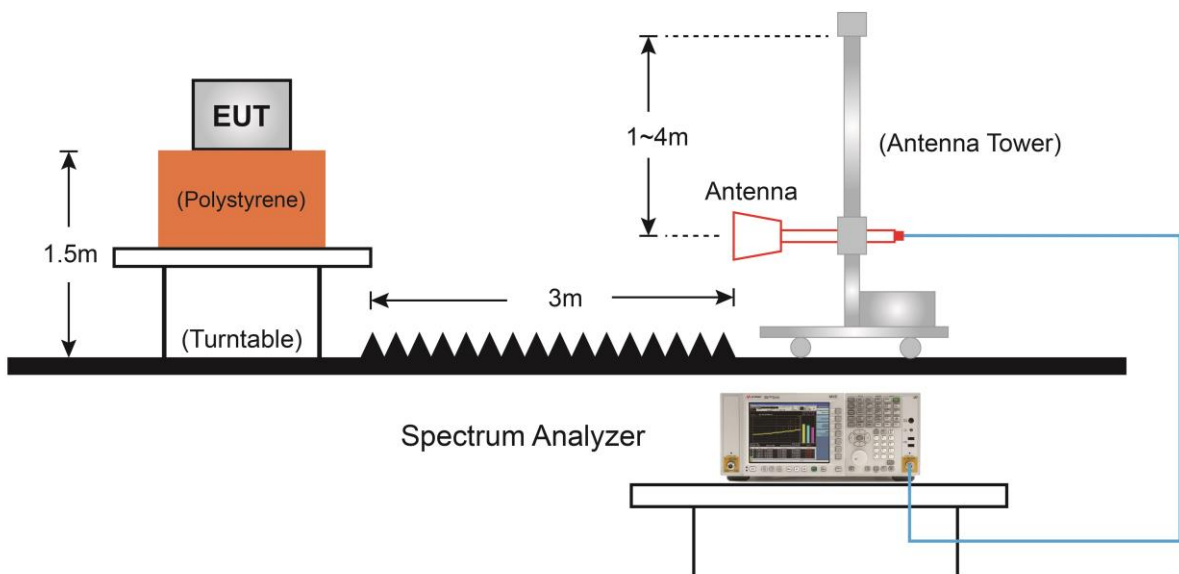

5.3.5. Test Results

Test Site	SIP-AC2	Test Engineer	Chase Zhu
Test Date	2021/07/25		

Time On (ms)	One Period (ms)	Duty Cycle (%)	Duty Cycle Factor (dB)
21.85	100	21.85	-13.211

Note: Duty Cycle Factor (dB) = $20 \cdot \log_{10}(\text{Duty Cycle})$ (dB).

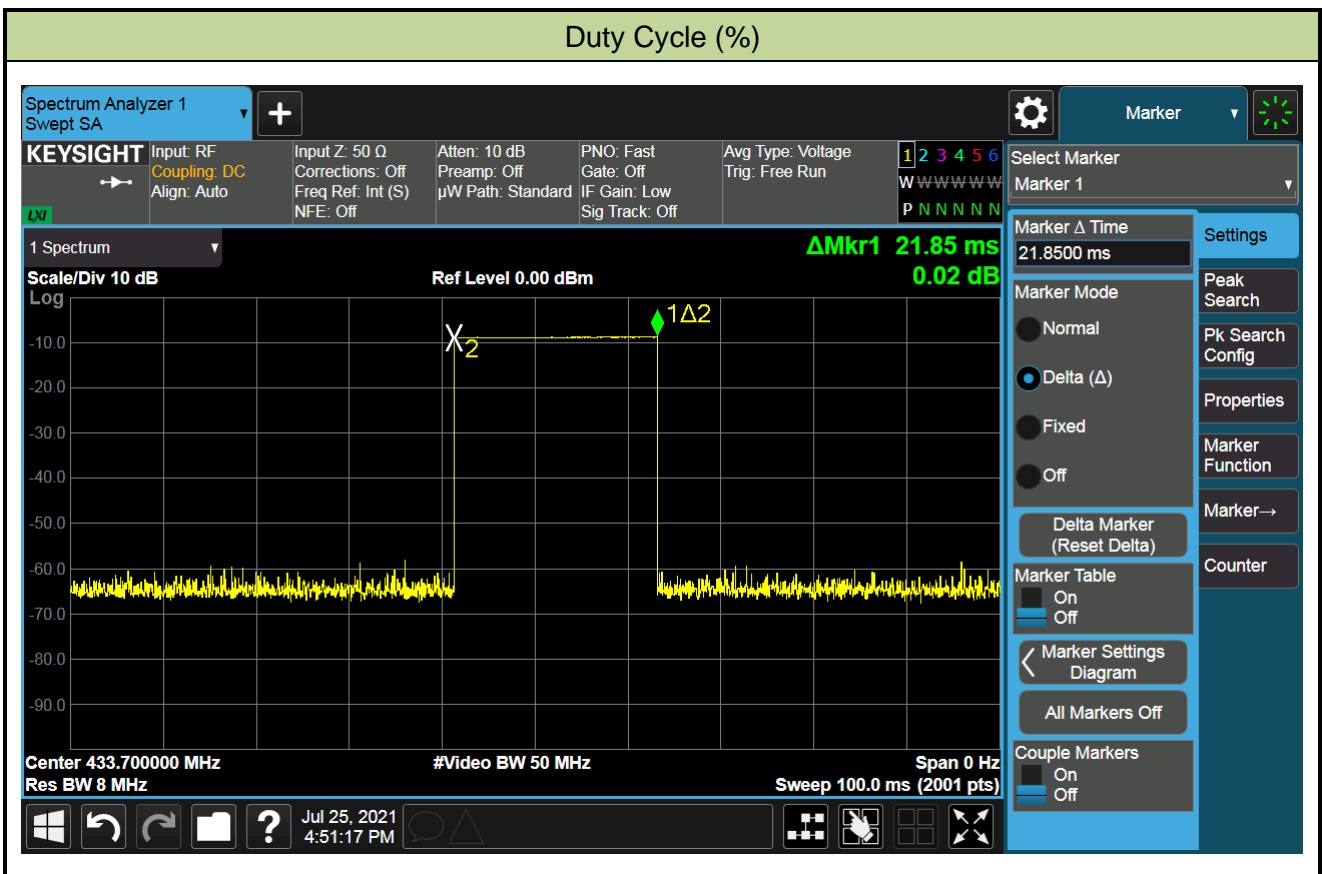

Test Site	SIP-AC2	Test Engineer	Chase Zhu
Test Date	2021/07/25		
Test Item	Fundamental Radiated Emission		

Frequency (MHz)	Reading Level (dB μ V)	Factor (dB)	Duty Cycle Factor (dB)	Measure Level (dB μ V/m)	Limit (dB μ V/m)	Margin (dB)	Detector	Polarization
433.7	39.966	22.530	N/A	62.495	100.818	-38.323	PK	Vertical
	39.966	22.530	-13.211	49.284	80.818	-31.534	AV	Vertical

Note 1: Measure Level (dB μ V/m) = Reading Level (dB μ V) + Factor (dB)

Average Measure Level = Peak Measure Level + Duty Cycle Factor

Factor (dB) = Cable Loss (dB) + Antenna Factor (dB/m)

Note 2: Only the worst polarization data was shown in report.

Test Site	SIP-AC2	Test Engineer	Edward Zhang
Test Date	2021/07/22		
Test Item	Radiated Spurious Emissions		

Frequency (MHz)	Reading Level (dB μ V)	Factor (dB)	Duty Cycle Factor (dB)	Measure Level (dB μ V/m)	Limit (dB μ V/m)	Margin (dB)	Detector	Polarization
3035.000	57.693	-14.958	N/A	42.735	80.818	-38.083	PK	Horizontal
3035.000	57.693	-14.958	-13.211	29.524	60.818	-31.294	AV	Horizontal
4770.000	55.050	-9.325	N/A	45.725	80.818	-35.093	PK	Horizontal
4770.000	55.050	-9.325	-13.211	32.514	60.818	-28.304	AV	Horizontal
5205.000	57.454	-8.484	N/A	48.970	80.818	-31.848	PK	Horizontal
5205.000	57.454	-8.484	-13.211	35.759	60.818	-25.059	AV	Horizontal
5637.500	54.010	-8.055	N/A	45.954	80.818	-34.864	PK	Horizontal
5637.500	54.010	-8.055	-13.211	32.743	60.818	-28.075	AV	Horizontal
2415.000	59.740	-16.145	N/A	43.595	80.818	-37.223	PK	Vertical
2415.000	59.740	-16.145	-13.211	30.384	60.818	-30.434	AV	Vertical
2602.500	60.738	-16.380	N/A	44.358	80.818	-36.460	PK	Vertical
2602.500	60.738	-16.380	-13.211	31.147	60.818	-29.671	AV	Vertical
3035.000	63.581	-14.958	N/A	48.623	80.818	-32.195	PK	Vertical
3035.000	63.581	-14.958	-13.211	35.412	60.818	-25.406	AV	Vertical
3470.000	56.939	-14.143	N/A	42.796	80.818	-38.022	PK	Vertical
3470.000	56.939	-14.143	-13.211	29.585	60.818	-31.233	AV	Vertical
5205.000	54.354	-8.484	N/A	45.870	80.818	-34.948	PK	Vertical
5205.000	54.354	-8.484	-13.211	32.659	60.818	-28.159	AV	Vertical
5637.500	54.874	-8.055	N/A	46.818	80.818	-34.000	PK	Vertical
5637.500	54.874	-8.055	-13.211	33.607	60.818	-27.211	AV	Vertical

Note 1: Peak Measure Level (dB μ V/m) = Reading Level (dB μ V) + Factor (dB)

Factor (dB) = Cable Loss (dB) + Antenna Factor (dB/m) – Pre_Amplifier Gain (dB)

Average Measure Level = Peak Measure Level + Duty Cycle Factor

Note 2: The test trace is same as the ambient noise (the test frequency range: 9 kHz ~ 30 MHz), therefore no data appear in the report.

5.4. 20dB Bandwidth

5.4.1. Test Limit

According to FCC Part 15.231(c), the bandwidth of the emission shall be no wider than 0.25% of the center frequency for devices operating above 70MHz and below 900MHz. Bandwidth is determined at the points 20 dB down from the modulated carrier.

5.4.2. Test Procedure used

ANSI C63.10-2013 Clause 6.9.2 (20dB Bandwidth)

5.4.3. Test Setting

20dB Bandwidth:

1. Set the spectrum span shall be between 2 times and 5 times the OBW
2. Set RBW = 1% to 5% of the OBW
3. VBW $\geq 3 \times$ RBW
4. Detector = Peak
5. Trace mode = Max hold
6. Sweep = Auto couple

5.4.4. Test Setup

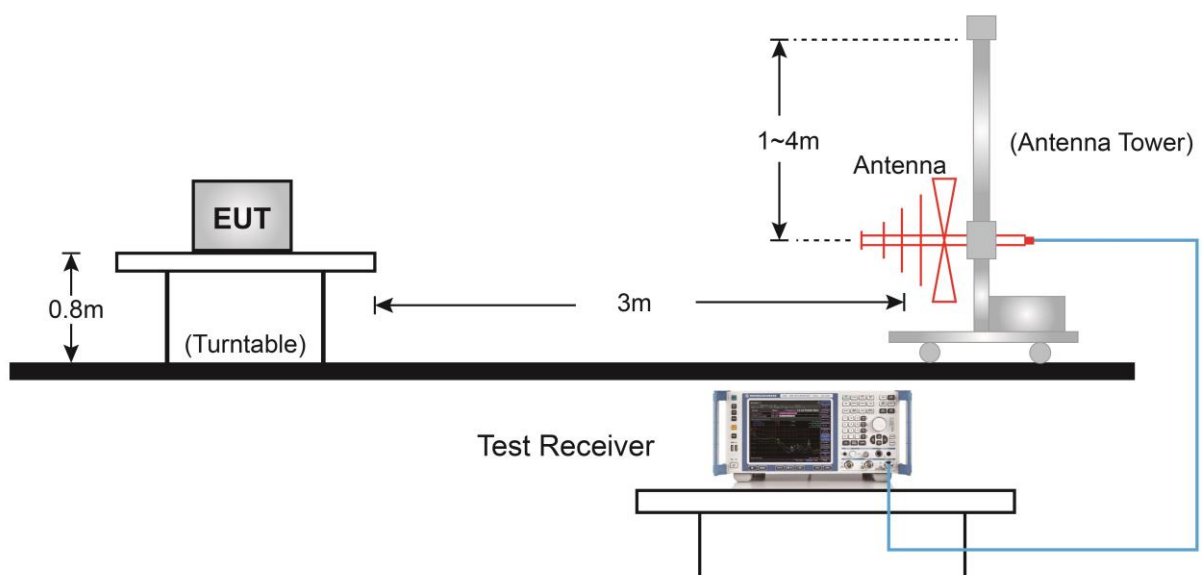

5.4.5. Test Result

Test Site	WZ-AC1	Test Engineer	Edward Zhang
Test Date	2021/07/21		

Center Frequency (MHz)	20dB Bandwidth (kHz)	Limit (kHz)	Result
433.7	89.17	≤ 1084.25	Pass

Note: Limit = Center Frequency (MHz) * 0.25% = 433.7 MHz * 0.25% = 1084.25 kHz

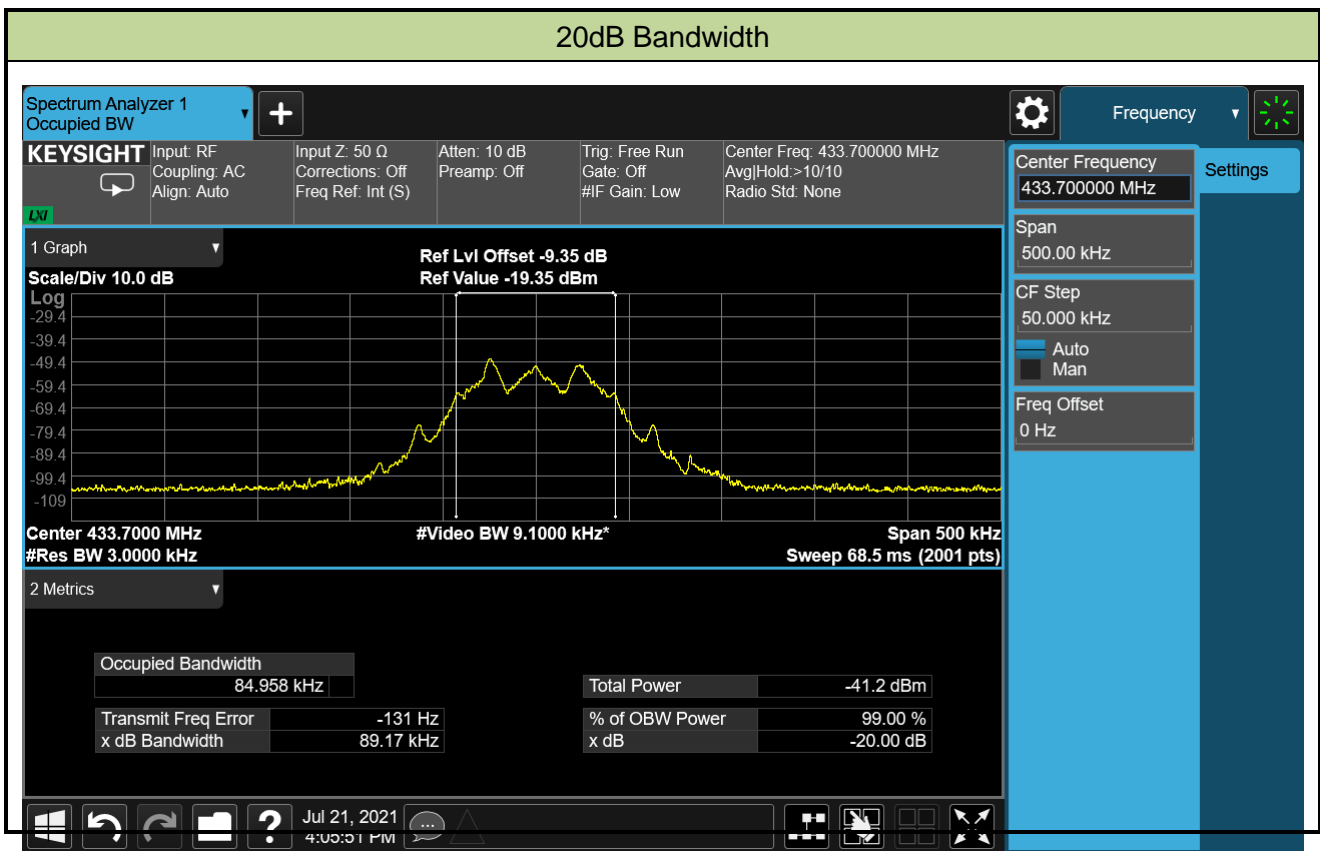

5.5. Transmission Time

5.5.1. Test Limit

According to 15.231(a)(3):

Polling or supervision transmissions, including data, to determine system integrity of transmitters used in security or safety applications are allowed if the total duration of transmissions does not exceed more than two seconds per hour for each transmitter. There is no limit on the number of individual transmissions, provided the total transmission time does not exceed two seconds per hour.

5.5.2. Test Procedure

ANSI C63.10-2013 Clause 7.4.

5.5.3. Test Setting

1. Trigger the spectrum analyzer sweep on the RF waveform of the unlicensed wireless device.
2. Set the spectrum analyzer sweep time greater than the specified time for periodic operation.
3. Manually activate and deactivate the unlicensed wireless device and confirm that it ceases transmission within the specified time of deactivation.
4. Verify and document that periodic transmissions at regular predetermined intervals do not exist, except where regulatory requirements allow polling or supervision transmissions, including data, to determine system integrity. Compliance is addressed by an attestation supported by the equipment theory of operation.

5.5.4. Test Setup

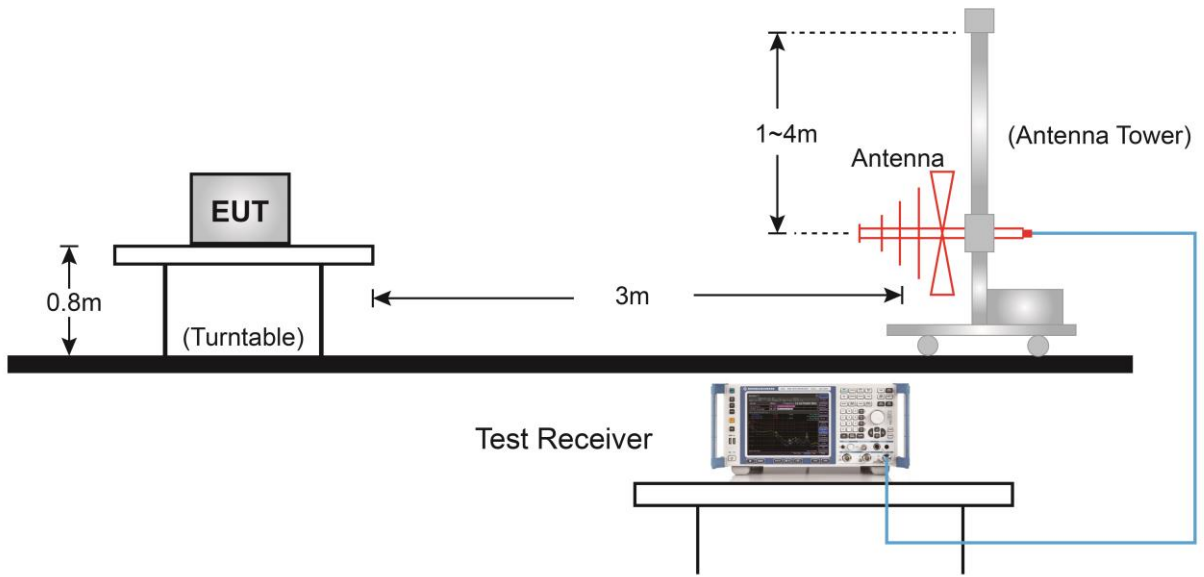

5.5.5. Test Result

Test Site	WZ-AC1	Test Engineer	Bruce Wang
Test Date	2021/06/29		

Frequency	Item	Measured Value	Number of transmissions at 1 hour	Total transmissions time	Limit	Result
433.7MHz	Transmission Time (T_{on})	21.85 ms	12	262.2ms	≤ 2 s	Pass

Note: Number of transmissions at 1 hour is declared by manufacturer, details refer to the operational description.

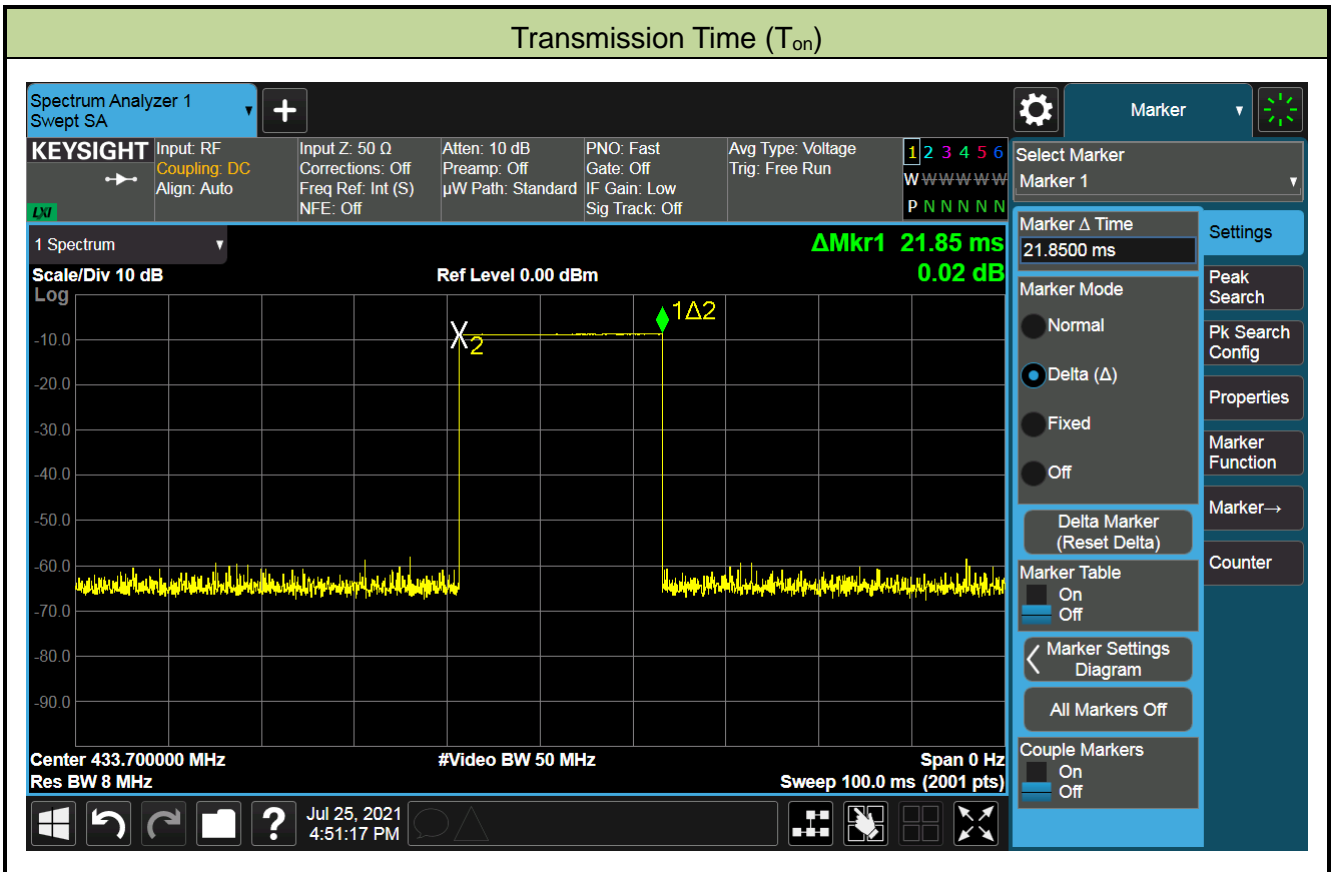

6. CONCLUSION

The data collected relate only the item(s) tested and show that the unit is compliance with FCC Part 15.231 Rules.

————— The End —————

Appendix A - Test Setup Photograph

Refer to "2104RSU070-UT" file.

Appendix B - EUT Photograph

Refer to "2104RSU070-UE" file.