

RADIO TEST REPORT

Report No: STS1705232F01

Issued for

Lovehoney Ltd

100 Locksbrook Road, Bath, BA1 3EN, UK

| | |
|-----------------------|---|
| Product Name: | Love honey Desire Luxury USB Rechargeable Rimming Butt Plug |
| Brand Name: | N/A |
| Model Name: | LH-69962 |
| Series Model: | N/A |
| FCC ID: | 2ADSQLH-69962 |
| Test Standard: | FCC Part 15.231 |

Any reproduction of this document must be done in full. No single part of this document may be reproduced without permission from BZT, All Test Data Presented in this report is only applicable to presented Test sample.

BZT Testing Technology Co., Ltd

Add. : Buliding 17, Xinghua Road Xingwei industrial Park Fuyong,
Baoan District, Shenzhen, Guangdong, China

TEL: +86-755 3307 1680 FAX: +86-755 27341758 E-mail:bruce@bzt.Cn

TEST REPORT CERTIFICATION

Applicant's name: Lovehoney Ltd
Address: 100 Locksbrook Road, Bath, BA1 3EN, UK
Manufacture's Name.....: Lovehoney Ltd
Address: 100 Locksbrook Road, Bath, BA1 3EN, UK

Product description

Product name: Love honey Desire Luxury USB Rechargeable
Rimming Butt Plug
Brand name: N/A
Model and/or type reference.....: LH-69962
Standards: FCC Part 15.231
Test procedure: ANSI C63.10-2013

This device described above has been tested by BZT , the test results show that the equipment under test (EUT) is in compliance with the FCC requirements. And it is applicable only to the tested sample identified in the report.

This report shall not be reproduced except in full, without the written approval of BZT, this document may be altered or revised by BZT, personal only, and shall be noted in the revision of the document.

Date of Test.....

Date of performance of tests 27 May. 2017 ~ 02 Jun. 2017

Date of Issue..... 05 Jun. 2017

Test Result..... **Pass**

Testing Engineer :



(Leo li)

Technical Manager :



(Tony liu)

Authorized Signatory :



(Vita Li)

TABLE OF CONTENTS

| | |
|---|-----------|
| 1. SUMMARY OF TEST RESULTS | 6 |
| 1.1 TEST FACTORY | 7 |
| 1.2 MEASUREMENT UNCERTAINTY | 7 |
| 2. GENERAL INFORMATION | 8 |
| 2.1 GENERAL DESCRIPTION OF EUT | 8 |
| 2.2 DESCRIPTION OF TEST MODES | 9 |
| 2.3 BLOCK DIGRAM SHOWING THE CONFIGURATION OF SYSTEM TESTED | 9 |
| 2.4 DESCRIPTION OF SUPPORT UNITS | 10 |
| 2.5 EQUIPMENTS LIST FOR ALL TEST ITEMS | 11 |
| 3. EMC EMISSION TEST | 12 |
| 3.1 CONDUCTED EMISSION MEASUREMENT | 12 |
| 3.2 TEST PROCEDURE | 13 |
| 3.3 TEST SETUP | 13 |
| 3.4 EUT OPERATING CONDITIONS | 13 |
| 3.5 TEST RESULTS | 14 |
| 4. RADIATED EMISSION MEASUREMENT | 15 |
| 4.1 RADIATED EMISSION LIMITS | 15 |
| 4.2 TEST PROCEDURE | 16 |
| 4.3 DEVIATION FROM TEST STANDARD | 16 |
| 5. BANDWIDTH TEST | 23 |
| 5.1 APPLIED PROCEDURES / LIMIT | 23 |
| 5.2 TEST REQUIREMENTS | 23 |
| 5.3 TEST PROCEDURE | 23 |
| 5.4 TEST SETUP | 23 |
| 5.5 EUT OPERATION CONDITIONS | 23 |
| 5.6 TEST RESULTS | 24 |
| 6. DUTY CYCLE | 25 |
| 6.1 TEST PROCEDURE | 25 |
| 6.2 TEST SETUP | 25 |
| 6.3 EUT OPERATION CONDITIONS | 25 |
| 6.4 TEST RESULTS | 26 |
| 7. AUTOMATICALLY DEACTIVATE | 28 |
| 7.1 STANDARD REQUIREMENT | 28 |
| 7.2 TEST PROCEDURE | 28 |

TABLE OF CONTENTS

| | |
|---|-----------|
| 8. ANTENNA REQUIREMENT | 30 |
| 8.1 STANDARD REQUIREMENT | 30 |
| 8.2 EUT ANTENNA | 30 |
| APPENDIX 1- PHOTOS OF TEST SETUP | 31 |

Revision History

| Rev. | Issue Date | Report NO. | Effect Page | Contents |
|------|--------------|---------------|-------------|---------------|
| 00 | 05 Jun. 2017 | STS1705232F01 | ALL | Initial Issue |
| | | | | |

1. SUMMARY OF TEST RESULTS

Test procedures according to the technical standards:

| FCC Part 15.231,Subpart C | | | |
|----------------------------------|----------------------------|----------|--------|
| Standard Section | Test Item | Judgment | Remark |
| 15.207 | Conducted Emission | N/A | -- |
| 15.205(a)/15.209/ 15.231.(b) | Radiated Spurious Emission | PASS | -- |
| 15.231(a)(1)/ 15.231(b)(2) | Transmission requirement | PASS | -- |
| 15.231(C) | 20 dB Bandwidth | PASS | -- |
| 15.203 | Antenna Requirement | PASS | -- |

NOTE: (1)"N/A" denotes test is not applicable in this Test Report

(2) All tests are according to ANSI C63.10-2013

1.1 TEST FACTORY

BZT Testing Technology Co., Ltd.
 Buliding 17, Xinghua Road Xingwei industrial Park Fuyong,
 Baoan District, Shenzhen, Guangdong, China
 FCC Registration No.: 701733

1.2 MEASUREMENT UNCERTAINTY

The reported uncertainty of measurement $y \pm U$, where expanded uncertainty U is based on a standard uncertainty multiplied by a coverage factor of $k=2$, providing a level of confidence of approximately **95** %.

| No. | Item | Uncertainty |
|-----|--|---------------------------|
| 1 | Conducted Emission (9KHz-150KHz) | $\pm 2.88\text{dB}$ |
| 2 | Conducted Emission (150KHz-30MHz) | $\pm 2.67\text{dB}$ |
| 3 | RF power,conducted | $\pm 0.70\text{dB}$ |
| 4 | Spurious emissions,conducted | $\pm 1.19\text{dB}$ |
| 5 | All emissions,radiated(<1G) 30MHz-200MHz | $\pm 2.83\text{dB}$ |
| 6 | All emissions,radiated(<1G) 200MHz-1000MHz | $\pm 2.94\text{dB}$ |
| 8 | Temperature | $\pm 0.5^{\circ}\text{C}$ |
| 9 | Humidity | $\pm 2\%$ |

2. GENERAL INFORMATION

2.1 GENERAL DESCRIPTION OF EUT

| | |
|-------------------------|--|
| Equipment | Love honey Desire Luxury USB Rechargeable Rimming Butt Plug |
| Trade Name | N/A |
| Model Name | LH-69962 |
| Series Model | N/A |
| Model Difference | N/A |
| Frequency band | 433.92MHz |
| Power Rating | DC 3.7 V |
| Hardware version number | TX: W0041TX V1.0 Hardware RX: W0041RX V1.0 Hardware |
| Software version number | TX: SDG335TX V02 FOR software RX: SDG335RX V03 FOR software |
| Connecting I/O Port(s) | N/A |

Note:

- For a more detailed features description, please refer to the manufacturer's specifications or the User's Manual.

2. Table for filed Antenna

| Ant. | Brand | Model Name | Antenna Type | Connector | Gain (dBi) | NOTE |
|------|-------|------------|--------------|-----------|------------|---------|
| 1 | N/A | LH-69962 | PCB | N/A | 0 | Antenna |

The EUT antenna is PCB Antenna. No antenna other than that furnished by the responsible party shall be used with the device.

2.2 DESCRIPTION OF TEST MODES

To investigate the maximum EMI emission characteristics generated from EUT, the test system was pre-scanning tested based on the consideration of following EUT operation mode or test configuration mode which possibly have effect on EMI emission level. Each of these EUT operation mode(s) or test configuration mode(s) mentioned above was evaluated respectively.

| Pretest Mode | Description |
|--------------|-------------|
| Mode 1 | TX Mode |

| | For Radiated Emission |
|-----------------|------------------------------|
| Final Test Mode | Description |
| Mode 1 | TX Mode |

2.3 BLOCK DIAGRAM SHOWING THE CONFIGURATION OF SYSTEM TESTED

During test, Keep EUT is in continuous transmission mode, Both open button and closed button have been tested, The two keys were tested to assess and only record the worst case in the report(Open button).

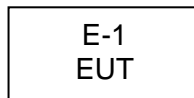

2.4 DESCRIPTION OF SUPPORT UNITS

The EUT has been tested as an independent unit together with other necessary accessories or support units. The following support units or accessories were used to form a representative test configuration during the tests.

| Item | Equipment | Mfr/Brand | Model/Type No. | Serial No. | Note |
|------|--|-----------|----------------|------------|------|
| E-1 | Love honey Desire Luxury USB Rechargeable Rimming Butt Plug | N/A | LH-69962 | N/A | EUT |
| | | | | | |
| | | | | | |
| | | | | | |
| | | | | | |
| | | | | | |

| Item | Shielded Type | Ferrite Core | Length | Note |
|------|---------------|--------------|--------|------|
| N/A | N/A | N/A | N/A | N/A |
| | | | | |
| | | | | |
| | | | | |
| | | | | |

Note:

(1) For detachable type I/O cable should be specified the length in cm in 『Length』 column.

2.5 EQUIPMENTS LIST FOR ALL TEST ITEMS

| Kind of Equipment | Manufacturer | Type No. | Serial No. | Last calibration | Calibrated until |
|-------------------------------------|--------------|-------------------------------|------------|------------------|------------------|
| Spectrum Analyzer | Agilent | E4407B | MY50140340 | 2016.10.23 | 2017.10.22 |
| Test Receiver | R&S | ESCI | 101427 | 2016.10.23 | 2017.10.22 |
| Bilog Antenna | TESEQ | CBL6111D | 34678 | 2014.11.24 | 2017.11.23 |
| Horn Antenna | Schwarzbeck | BBHA 9120D(1201) 1G-18G | 9120D-1343 | 2015.03.05 | 2018.03.04 |
| 50Ω Coaxial Switch | Anritsu | MP59B | 6200264416 | 2016.10.23 | 2017.10.22 |
| PreAmplifier | Agilent | 8449B | 60538 | 2016.10.23 | 2017.10.22 |
| Loop Antenna | EMCO | 6502 | 9003-2485 | 2016.03.06 | 2019.03.05 |
| Spectrum Analyzer | Agilent | E4407B | MY50140340 | 2016.10.23 | 2017.10.22 |
| Low frequency cable (9KHz-1GHz) | SCHWARZBECK | R01 | N/A | 2016.10.23 | 2017.10.22 |
| High frequency cable (1GHz-5GHz) | SCHWARZBECK | R02 | N/A | 2016.10.23 | 2017.10.22 |
| Temporary Antenna Connector | N/A | P9MSP9MS | N/A | 2016.10.23 | 2017.10.22 |
| RF Cable | Murrata | MXHS83QE300 0 | 2085751 | 2016.10.23 | 2017.10.22 |
| EMI Test Receiver | R&S | ESPI | 102086 | 2016.10.23 | 2017.10.22 |
| LISN | R&S | ENV216 | 101242 | 2016.10.23 | 2017.10.22 |
| LISN | EMCO | 3810/2NM | 000-23625 | 2016.10.23 | 2017.10.22 |
| Conduction Cable (150KHz-30MHz) | EM | C01 | N/A | 2016.10.23 | 2017.10.22 |

Note: The temporary antenna connector is soldered on the PCB board in order to perform conducted tests and this temporary antenna connector is listed in the equipment list.

3. EMC EMISSION TEST

3.1 CONDUCTED EMISSION MEASUREMENT

3.1.1 POWER LINE CONDUCTED EMISSION LIMITS

operating frequency band. In case the emission fall within the restricted band specified on Part 15. 207(a) limit in the table below has to be followed.

| FREQUENCY (MHz) | Class B (dBuV) | | Standard |
|-----------------|----------------|-----------|----------|
| | Quasi-peak | Average | |
| 0.15 -0.5 | 66 - 56 * | 56 - 46 * | CISPR |
| 0.50 -5.0 | 56.00 | 46.00 | CISPR |
| 5.0 -30.0 | 60.00 | 50.00 | CISPR |

| | | | |
|-----------|-----------|-----------|-----|
| 0.15 -0.5 | 66 - 56 * | 56 - 46 * | FCC |
| 0.50 -5.0 | 56.00 | 46.00 | FCC |
| 5.0 -30.0 | 60.00 | 50.00 | FCC |

Note:

- (1) The tighter limit applies at the band edges.
- (2) The limit of " * " marked band means the limitation decreases linearly with the logarithm of the frequency in the range.

The following table is the setting of the receiver

| Receiver Parameters | Setting |
|---------------------|----------|
| Attenuation | 10 dB |
| Start Frequency | 0.15 MHz |
| Stop Frequency | 30 MHz |
| IF Bandwidth | 9 kHz |

3.2 TEST PROCEDURE

- a. The EUT was placed 0.8 meters from the horizontal ground plane with EUT being connected to the power mains through a line impedance stabilization network (LISN). All other support equipments powered from additional LISN(s). The LISN provide 50 Ohm/ 50uH of coupling impedance for the measuring instrument.
- b. Interconnecting cables that hang closer than 40 cm to the ground plane shall be folded back and forth in the center forming a bundle 30 to 40 cm long.
- c. I/O cables that are not connected to a peripheral shall be bundled in the center. The end of the cable may be terminated, if required, using the correct terminating impedance. The overall length shall not exceed 1 m.
- d. LISN at least 80 cm from nearest part of EUT chassis.
- e. For the actual test configuration, please refer to the related Item –EUT Test Photos.

3.3 TEST SETUP

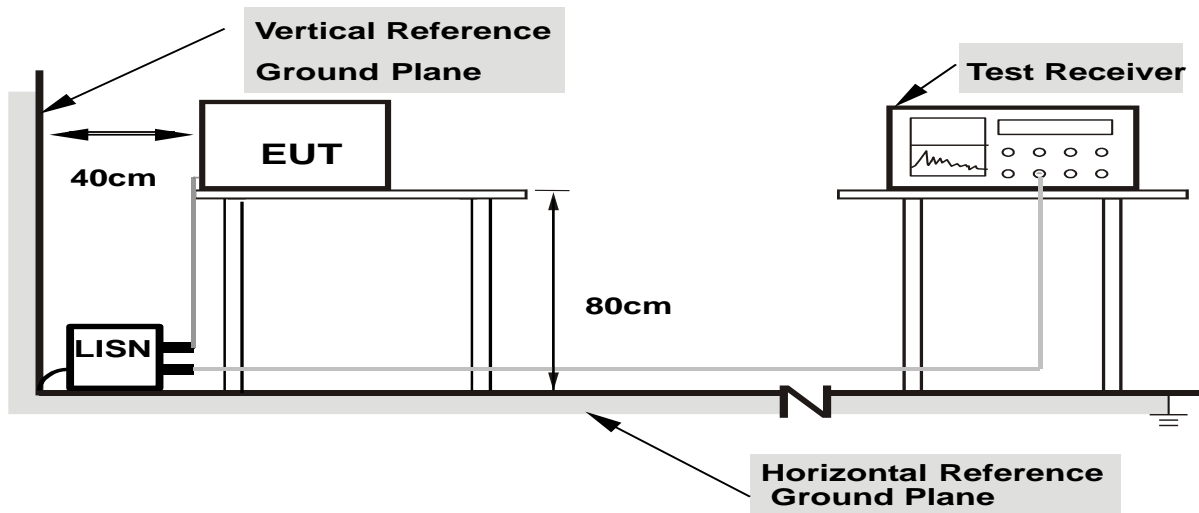

- Note: 1. Support units were connected to second LISN.**
2. Both of LISNs (AMN) are 80 cm from EUT and at least 80 cm from other units and other metal planes

3.4 EUT OPERATING CONDITIONS

The EUT was configured for testing in a typical fashion (as a customer would normally use it). The EUT has been programmed to continuously transmit during test. This operating condition was tested and used to collect the included data.

3.5 TEST RESULTS

| | | | |
|---------------|---------|--------------------|-----|
| Temperature: | 26 °C | Relative Humidity: | 54% |
| Pressure: | 1010hPa | Phase : | L/N |
| Test Voltage: | DC 3 V | Test Mode: | N/A |

Note: EUT is only power by battery, So it is not applicable for this test.

4. RADIATED EMISSION MEASUREMENT

4.1 RADIATED EMISSION LIMITS

In case the emission fall within the restricted band specified on Part 15.205(a), then the Part 15.209(a) and Part 15.231(b) limit in the table below has to be followed.

LIMITS OF RADIATED EMISSION MEASUREMENT (0.009MHz - 1000MHz)

| Frequencies (MHz) | Field Strength (micorvolts/meter) | Measurement Distance (meters) |
|-------------------|-----------------------------------|-------------------------------|
| 0.009~0.490 | 2400/F(KHz) | 300 |
| 0.490~1.705 | 24000/F(KHz) | 30 |
| 1.705~30.0 | 30 | 30 |
| 30~40.66 | 100 | 3 |
| 40.70~70 | 100 | 3 |

| Fundamental Frequency (MHz) | Field Strength of fundamental (microvolts/meter) | Field Strength of Unwanted Emissions (microvolts/meter) |
|-----------------------------|--|---|
| 40.66~40.70 | 2,250 | 225 |
| 70~130 | 1,250 | 125 |
| 130~174 | 1,250 to 3,750** | 125 to 375** |
| 174~260 | 3750 | 375 |
| 260~470 | 3,750 to 12,500** | 375 to 1,250** |
| Above 470 | 12,500 | 1,250 |

LIMITS OF RADIATED EMISSION MEASUREMENT (Above 1000MHz)

| FREQUENCY (MHz) | Class B (dBuV/m) (at 3M) | |
|-----------------|--------------------------|---------|
| | PEAK | AVERAGE |
| Above 1000 | 74 | 54 |

NOTE:

- (1)The limit for radiated test was performed according to FCC PART 15C.
- (2)Emission level (dBuV/m)=20log Emission level (uV/m).

| Spectrum Parameter | Setting |
|---------------------------------------|-----------------------|
| Attenuation | Auto |
| Start Frequency | 1000 MHz |
| Stop Frequency | 10th carrier harmonic |
| RB / VB (emission in restricted band) | 1 MHz / 3 MHz |

| Receiver Parameter | Setting |
|------------------------|--------------------------------------|
| Attenuation | Auto |
| Start ~ Stop Frequency | 9kHz~90kHz / RB 200Hz for PK & AV |
| Start ~ Stop Frequency | 90kHz~110kHz / RB 200Hz for QP |
| Start ~ Stop Frequency | 110kHz~490kHz / RB 200Hz for PK & AV |
| Start ~ Stop Frequency | 490kHz~30MHz / RB 9kHz for QP |
| Start ~ Stop Frequency | 30MHz~1000MHz / RB 120kHz for QP |

4.2 TEST PROCEDURE

- a. The test is performed in a 3m Semi-Anechoic Chamber; the antenna factor, cable loss and so on of the site (factors) is calculated to correct the reading. The EUT is placed on a 0.8m high insulating Turn Table, and keeps 3m away from the Test Antenna, which is mounted on a variable-height antenna master tower.
During test, The table was rotated 360 degrees to determine the position of the highest radiation.
- b. In the frequency range of 9KHz to 30MHz, magnetic field is measured with Loop Test Antenna. The Test Antenna is positioned with its plane vertical at 1m distance from the EUT. The center of the Loop Test Antenna is 1m above the ground. During the measurement the Loop Test Antenna rotates about its vertical axis for maximum response at each azimuth about the EUT.
- c. In the frequency range 30MHz-1GHz, Bi-Log Test Antenna used. Test Antenna is 3m away from the EUT. Test Antenna height is varied from 1m to 4m above the ground to determine the maximum value of the field strength. The emission levels at both horizontal and vertical polarizations should be tested.
- d. In the frequency above 1GHz, Place the measurement antenna 3m away from the EUT for each area of the EUT determined to be a source of emissions at the specified measurement distance, while keeping the measurement antenna aimed at the source of emissions at each frequency of significant emissions, with polarization oriented for maximum response. The measurement antenna elevation for maximum emissions shall be restricted to a range of heights of from 1 m to 4 m above the ground or reference ground plane.
- f. The initial step in collecting conducted emission data is a spectrum analyzer peak detector mode pre-scanning the measurement frequency range. Significant peaks are then marked and then Quasi Peak detector mode re-measured.
- g. If the Peak Mode measured value compliance with and lower than Quasi Peak Mode Limit, the EUT shall be deemed to meet QP Limits and then no additional QP Mode measurement performed.
- h. For the actual test configuration, please refer to the related Item –EUT Test Photos.

Both horizontal and vertical antenna polarities and performed pretest to three orthogonal axis were tested. The worst case emissions were reported

4.3 DEVIATION FROM TEST STANDARD

No deviation

4.4 TEST SETUP

(A) Radiated Emission Test-Up Frequency Below 30MHz

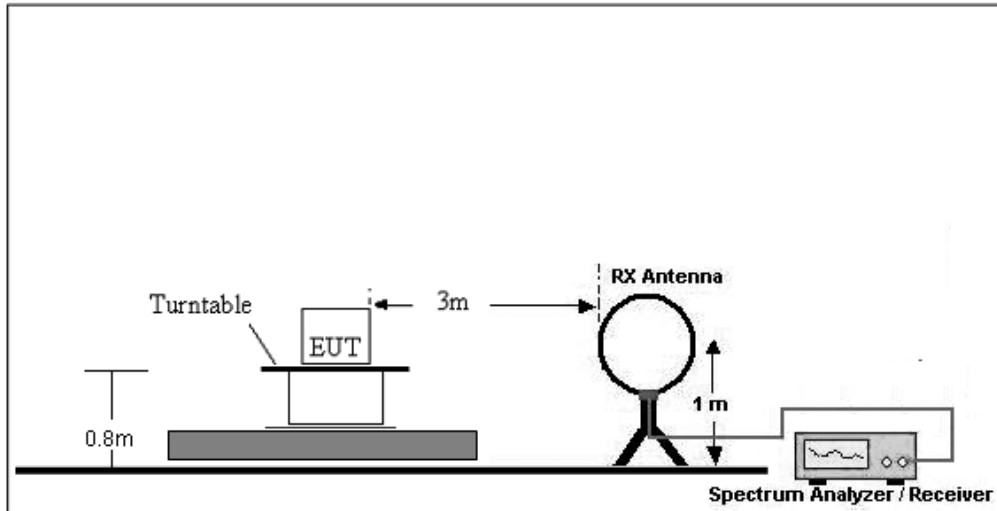

(B) Radiated Emission Test-Up Frequency 30MHz~1GHz

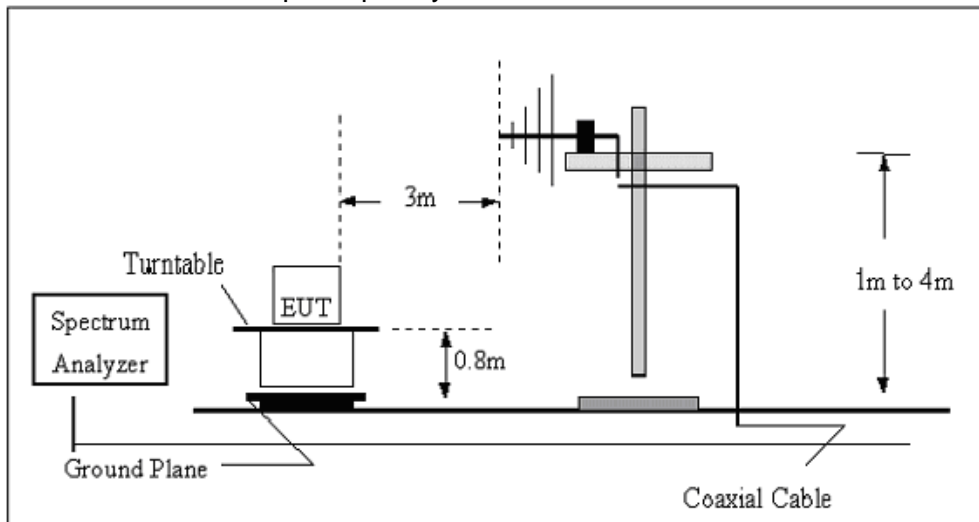

(C) Radiated Emission Test-Up Frequency Above 1GHz

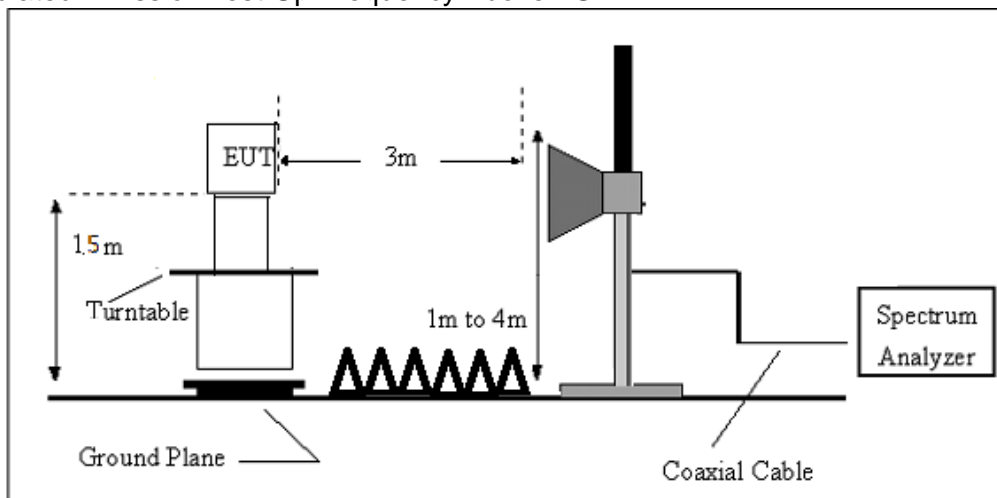

4.5 EUT OPERATING CONDITIONS

The EUT tested system was configured as the statements of 2.4 Unless otherwise a special operating condition is specified in the follows during the testing.

4.6 TEST RESULTS

INTRODUCTION TO PDCF

reference: (§15.35 Measurement detector functions and bandwidths.)

- a. Part 15 of the FCC Rules provides for the operation of low power communication devices without an individual license (e.g., intrusion detectors, pulsed water tank level gauges, etc.), subject to certain requirements. Some of these devices use extremely narrow pulses to generate wideband emissions, which are measured to determine compliance with the rules. These measurements are typically performed with a receiver or spectrum analyzer. Depending on a number of factors (e.g., resolution bandwidth, pulsewidth, etc.), the spectrum analyzer may not always display the true peak value of the measured emission. This effect, called “pulse desensitization,” relates to the capabilities of the measuring instrument. For the measurement and reporting of the true peak of pulsed emissions, it may be necessary to apply a “pulse desensitization correction factor” (PDCF) to the measured value, pursuant to 47 CFR 15.35(a).

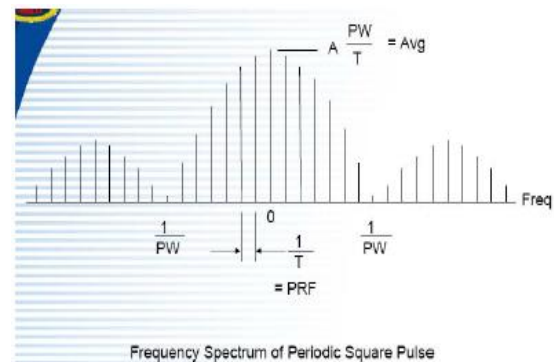
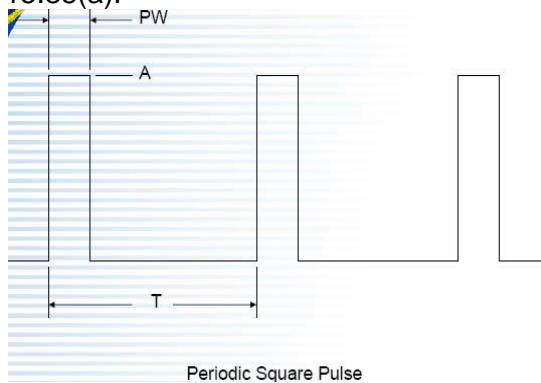

If using spectrum analyzer to measure pulse signal , it have to make sure the RBW use is at least $2/PW$.

•When RBW is less than $2/PW$, you are able to measure the true peak level of the pulse signal. If this is the case , PDCF is required to compensate to determine true peak value.

Pulse desensitization:

PW =24667usec,Period=55330usec, Level=A

RBW>2/PW=0.081K , 1/T=0.018K

NOTE: $2 / PW < RBW$, first don't need

- b. For the actual test, please refer to the ANSI C63.10,Annex C refer to section 5 for more detail

4.7 TEST RESULTS

(Radiated Emission<30MHz (9KHz-30MHz, H-field))

| Freq. | Reading | Limit | Margin | State |
|-------|----------|----------|--------|-------|
| (MHz) | (dBuV/m) | (dBuV/m) | (dB) | P/F |
| -- | -- | -- | -- | PASS |
| -- | -- | -- | -- | PASS |

Note: The amplitude of spurious emissions which are attenuated by more than 20dB below the permissible value has no need to be reported.

Distance extrapolation factor = $40 \log(\text{specific distance}/\text{test distance})$ (dB);

Limit line = specific limits(dBuv) + distance extrapolation factor.

Between 30MHz – 5000 MHz

| | | | |
|---------------|---------|--------------------|------------|
| Temperature: | 26 °C | Relative Humidity: | 60% |
| Pressure: | 1010hPa | Phase: | Horizontal |
| Test Voltage: | DC 3 V | Test Mode: | Mode 1 |

| No. | Frequency (MHz) | Reading (dBuV) | Factor (dB) | Results (dBuV/m) | Limit (dBuV/m) | Margin (dB) | Detector |
|-----|-----------------|----------------|-------------|------------------|----------------|-------------|----------|
| 1 | 35.7490 | 37.58 | -11.74 | 25.84 | 40.00 | -14.16 | QP |
| 2 | 44.4308 | 40.78 | -20.53 | 20.25 | 40.00 | -19.75 | QP |
| 3 | 53.8817 | 41.17 | -19.38 | 21.79 | 43.50 | -21.71 | QP |
| 4 | 127.6645 | 42.46 | -19.10 | 23.36 | 43.50 | -20.14 | QP |
| 5 | 433.9200 | 77.17 | -10.90 | 66.27 | 100.83 | -34.56 | PK |
| 6 | 867.8400 | 46.14 | -2.61 | 43.53 | 80.83 | -37.30 | QP |

AV

| No. | Frequency (MHz) | Reading (dBuV) | Factor (dB) | Results (dBuV/m) | Limit (dBuV/m) | Margin (dB) | Detector |
|-----|-----------------|----------------|-------------|------------------|----------------|-------------|----------|
| 7 | 433.9200 | 66.27 | -6.86 | 59.41 | 80.83 | -21.42 | AV |

Remark:

1. All readings are Quasi-Peak and Average values.
2. Margin = Result (Result = Reading + Factor) – Limit

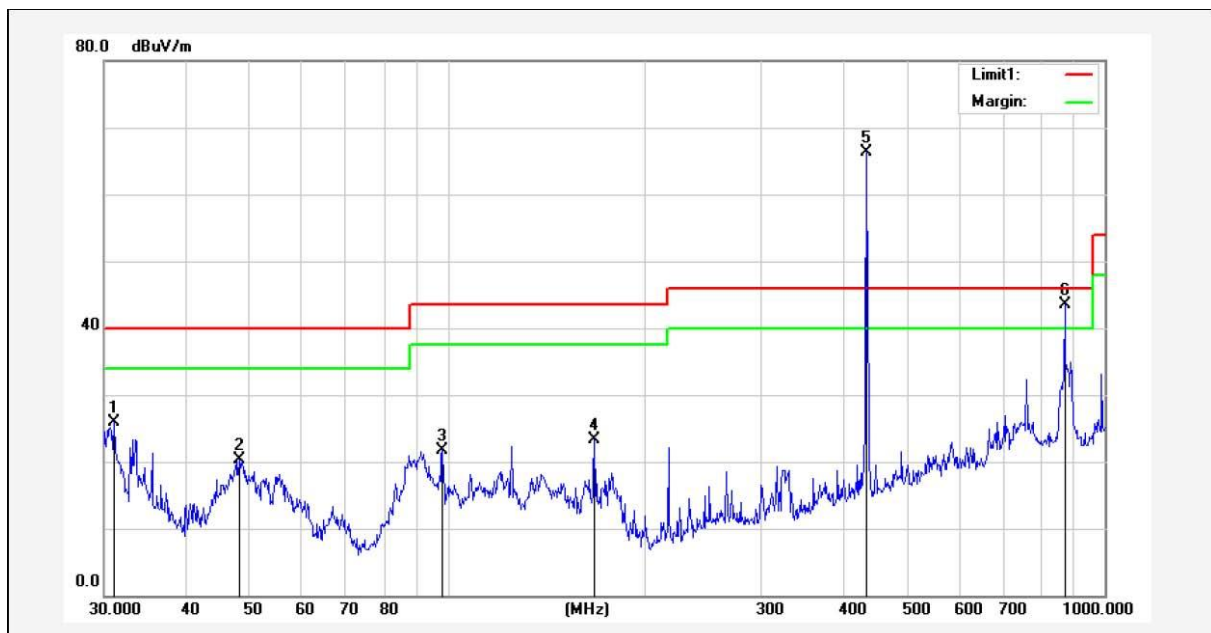

| | | | |
|---------------|---------|--------------------|----------|
| Temperature: | 26 °C | Relative Humidity: | 54% |
| Pressure: | 1010hPa | Phase: | Vertical |
| Test Voltage: | DC 3 V | Test Mode: | Mode 1 |

| No. | Frequency (MHz) | Reading (dBuV) | Factor (dB) | Results (dBuV/m) | Limit (dBuV/m) | Margin (dB) | Detector |
|-----|-----------------|----------------|-------------|------------------|----------------|-------------|----------|
| 1 | 35.7490 | 42.10 | -14.86 | 27.24 | 40.00 | -12.76 | QP |
| 2 | 44.4308 | 40.82 | -20.36 | 20.46 | 40.00 | -19.54 | QP |
| 3 | 53.8817 | 41.11 | -17.61 | 23.50 | 43.50 | -20.00 | QP |
| 4 | 127.6645 | 40.76 | -17.72 | 23.04 | 43.50 | -20.46 | QP |
| 5 | 433.9200 | 68.73 | -10.90 | 57.83 | 100.83 | -43.00 | PK |
| 6 | 867.8400 | 45.36 | -2.61 | 42.75 | 80.83 | -38.08 | QP |

AV

| No. | Frequency (MHz) | Reading (dBuV) | Factor (dB) | Results (dBuV/m) | Limit (dBuV/m) | Margin (dB) | Detector |
|-----|-----------------|----------------|-------------|------------------|----------------|-------------|----------|
| 7 | 433.9200 | 57.83 | -6.86 | 50.97 | 80.83 | -29.86 | AV |

Remark:

1. All readings are Quasi-Peak and Average values.
2. Margin = Result (Result = Reading + Factor) – Limit

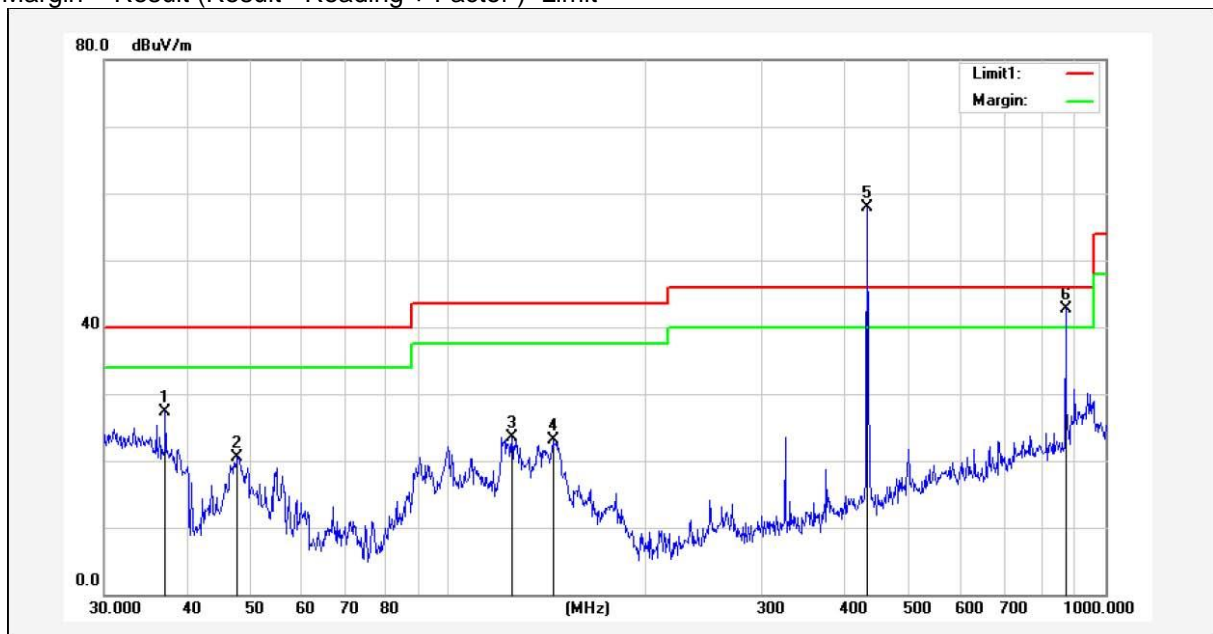

PEAK TEST RESULTS:

| Frequency | Reading | Detector | Amplifier | Loss | Antenna Factor | Corrected Factor | Corrected Amplitude | | | RX Antenna |
|-----------|----------------|------------|-----------|------|----------------|------------------|---------------------|----------------|--------|------------|
| | | | | | | | | Limit | Margin | Polar |
| (MHz) | (dB μ V/m) | (PK/QP/AV) | (dB) | (dB) | (dB/m) | (dB) | (dB μ V/m) | (dB μ V/m) | (dB) | (H/V) |
| 1301.76 | 59.68 | PK | 45.1 | 4.0 | 25.1 | 16.00 | 43.68 | 74 | -30.32 | H |
| 1301.76 | 63.15 | PK | 45.1 | 4.0 | 25.1 | 16.00 | 47.15 | 74 | -26.85 | V |
| 1735.68 | 61.46 | PK | 44.1 | 5.3 | 25 | 13.80 | 47.66 | 74 | -26.34 | H |
| 1735.68 | 60.25 | PK | 44.1 | 5.3 | 25 | 13.80 | 46.45 | 74 | -27.55 | V |
| 2169.6 | 61.23 | PK | 43.8 | 5.4 | 25.9 | 12.47 | 48.76 | 74 | -25.24 | H |
| 2169.6 | 61.03 | PK | 43.8 | 5.4 | 25.9 | 12.47 | 48.56 | 74 | -25.44 | V |
| 2603.3 | 61.02 | PK | 44.4 | 6.0 | 27.6 | 10.77 | 50.25 | 74 | -23.75 | H |
| 2603.3 | 59.23 | PK | 44.4 | 6.0 | 27.6 | 10.77 | 48.46 | 74 | -25.54 | V |

Note: Above 2.6 GHz The amplitude of spurious emissions which are attenuated by more than 20dB below the permissible value has no need to be reported.

AVG TEST RESULTS:

AV = Peak +20Log₁₀(duty cycle) =PK+(-6.30) [refer to section 5 for more detail]

| Frequency | PK Reading | Duty cycle Factor | Corrected Amplitude | FCC Part 15.231/15.209/205 | | RX Antenna |
|-----------|----------------|-------------------|---------------------|----------------------------|--------|------------|
| | | | | Limit | Margin | Polar |
| (MHz) | (dB μ V/m) | (dB) | (dB μ V/m) | (dB μ V/m) | (dB) | (H/V) |
| 1301.76 | 43.68 | -6.51 | 37.17 | 54 | -16.83 | H |
| 1301.76 | 47.15 | -6.51 | 40.64 | 54 | -13.36 | V |
| 1735.68 | 47.66 | -6.51 | 41.15 | 54 | -12.85 | H |
| 1735.68 | 46.45 | -6.51 | 39.94 | 54 | -14.06 | V |
| 2169.6 | 48.76 | -6.51 | 42.25 | 54 | -11.75 | H |
| 2169.6 | 48.56 | -6.51 | 42.05 | 54 | -11.95 | V |
| 2603.3 | 50.25 | -6.51 | 43.74 | 54 | -10.26 | H |
| 2603.3 | 48.46 | -6.51 | 41.95 | 54 | -12.05 | V |

5. BANDWIDTH TEST

5.1 APPLIED PROCEDURES / LIMIT

| FCC Part 15.231, Subpart C | | | | |
|----------------------------|--------------|--|-----------------------|--------|
| Section | Test Item | Limit | Frequency Range (MHz) | Result |
| 15.231(C) | 20 Bandwidth | The 20dB bandwidth of the emissions shall not exceed 0.25% of the center frequency | 433.92 | PASS |

| Spectrum Parameter | Setting |
|--------------------|-------------------------|
| Attenuation | Auto |
| Span Frequency | > Measurement Bandwidth |
| RB | 10 kHz (20dB Bandwidth) |
| VB | 30 kHz (20dB Bandwidth) |
| Detector | Peak |
| Trace | Max Hold |
| Sweep Time | Auto |

5.2 TEST REQUIREMENTS

The bandwidth of the emission shall be no wider than 0.25% of the center frequency for devices operating above 70 MHz and below 900 MHz. For devices operating above 900 MHz, the emission shall be no wider than 0.5% of the center frequency. Bandwidth is determined at the points 20 dB down from the modulated carrier.

5.3 TEST PROCEDURE

- The EUT was directly connected to the spectrum analyzer and antenna output port as show in the block diagram below.
- Spectrum Setting : RBW= 10KHz, VBW=30KHz, Sweep time = Auto.

5.4 TEST SETUP



5.5 EUT OPERATION CONDITIONS

TX mode.

5.6 TEST RESULTS

| Centre Frequency | Measurement | | |
|------------------|----------------------|------------|-----------------------|
| | 20dB Bandwidth (KHz) | Limit(kHz) | Frequency Range (MHz) |
| 433.92 MHz | 57 | 1084.8 | PASS |

CH00 -1Mbps

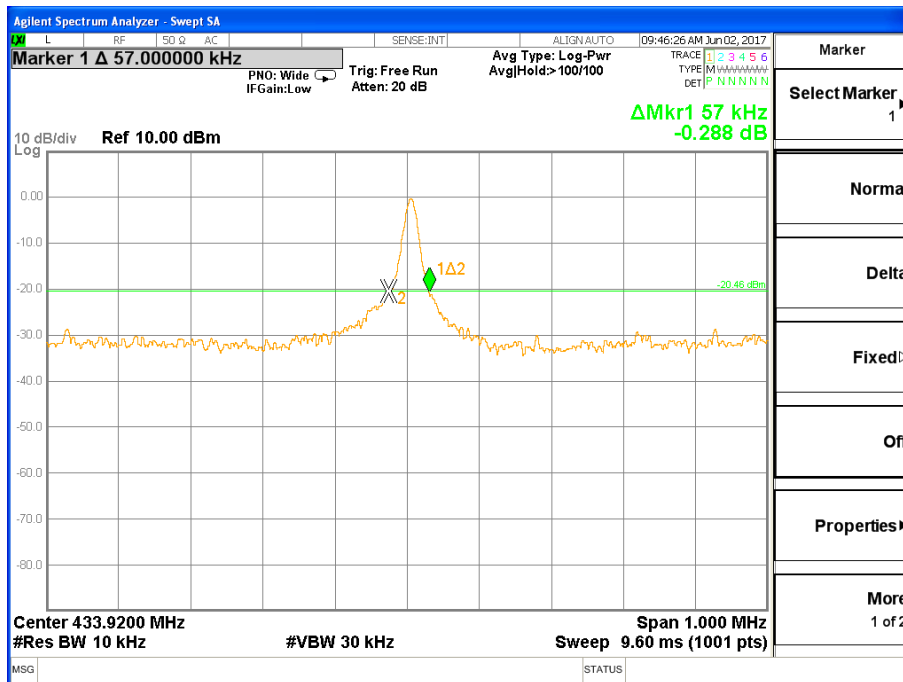

6. DUTY CYCLE

6.1 TEST PROCEDURE

The EUT was directly connected to the spectrum analyzer and antenna output port as show in the block diagram below.

The Duty Cycle Was Determined By The Following Equation: To Calculate The Actual Field Intensity,The Duty Cycle Correction Factor In Decibel Is Needed For Later Use And Can Be Obtained From Following Conversion

Duty Cycle(%)=Total On Interval In A Complete Pulse Train/ Length Of A Complete Pulse Train * %

Duty Cycle Correction Factor(Db)=20 * Log10(Duty Cycle(%))

6.2 TEST SETUP

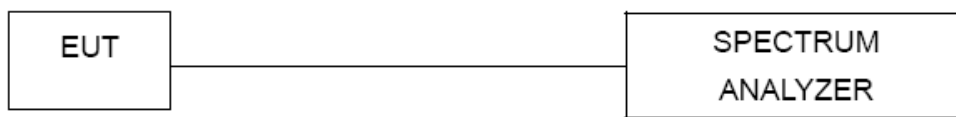

6.3 EUT OPERATION CONDITIONS

TX mode.

6.4 TEST RESULTS

| FCC Part 15.231(a) | |
|---|-----------------------------|
| Total On interval in a complete pulse train(ms) | $(5.167*1)+(1.5*13)=24.667$ |
| Length of a complete pulse train(ms) | 54.33 |
| Duty Cycle(%) | 45.40% |
| Duty Cycle Correction Factor(dB) | -6.86 |

Refer to the duty cycle plot (as below), This device meets the FCC requirement. Length of a complete pulse train

Remark: FCC part 15.35(c) required that a complete pulse train is more than 0.1 seconds, the measured field strength shall be determined from the average absolute voltage during a 0.1 second interval during which the field strength is at its maximum value.

TX Mode

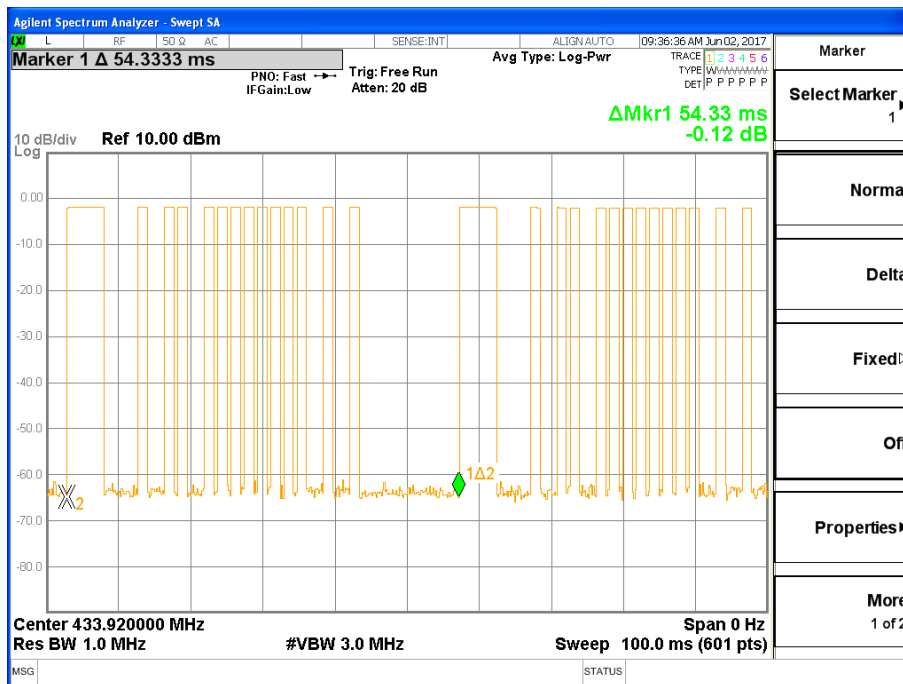

7. AUTOMATICALLY DEACTIVATE

7.1 STANDARD REQUIREMENT

A manually operated transmitter shall employ a switch that will automatically deactivate the transmitter within not more than 5 seconds of being released.

7.2 TEST PROCEDURE

The EUT was directly connected to the spectrum analyzer and antenna output port as show in the block diagram below.

Spectrum Setting : RBW= 100KHz, VBW=300KHz, Sweep time = Auto.

Note: Only press launch about 0.15 s

Note:

(1)Refer to the plot (As Below),We find a manually operated transmitter shall employ a switch that will automatically deactivate the transmitteri immediately, within not more than 5 seconds of being released.

(2)The EUT is comply with FCC PART 15 clause 15.231(a)(1).manually working mode are pre-tested.and only the worst result is reported.

7.3 TEST SETUP



7.4 TEST RESULTS

| Activation time | Limit(Sec) | Result |
|-----------------|------------|--------|
| 5 s | 5 s | Pass |

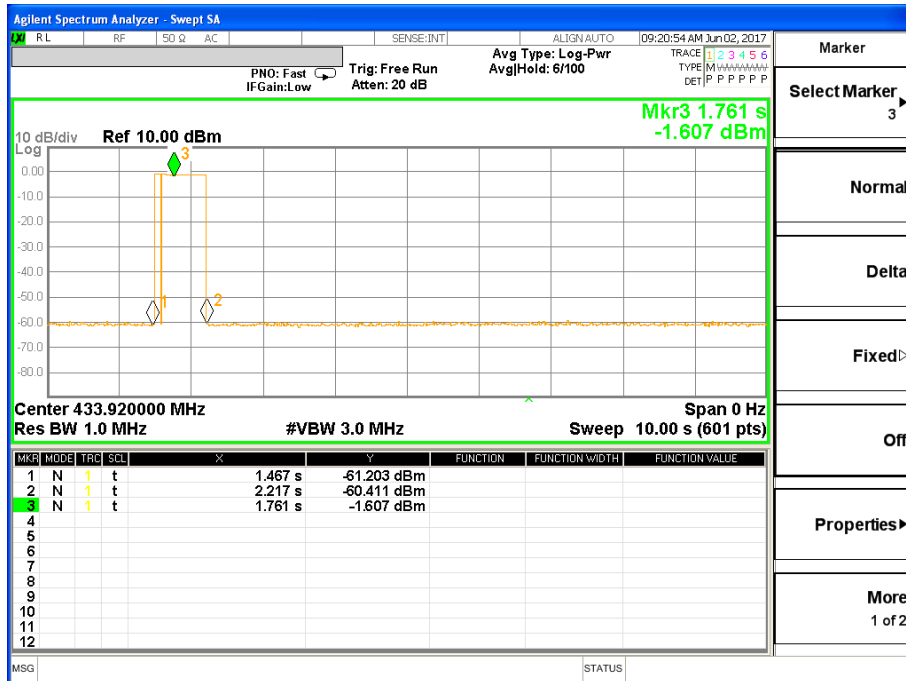

Mark 1: Hold down the Key(Start transmitting)

Mark 3: Loose the Key

Mark 2: Stop transmitting

Activation time= Mark 2- Mark 1=2.217-1.467=0.75s

8. ANTENNA REQUIREMENT

8.1 STANDARD REQUIREMENT

According to the FCC Part 15 Paragraph 15.203, an intentional radiator shall be designed to ensure that no antenna other than that furnished by the responsible party shall be used with the device. The use of a permanently attached antenna to the intentional radiator shall be considered sufficient to comply with the provisions of this section.

8.2 EUT ANTENNA

The EUT antenna is Internal PCB Antenna. It conforms to the standard requirements.

APPENDIX 1- PHOTOS OF TEST SETUP

Radiated Measurement Photos

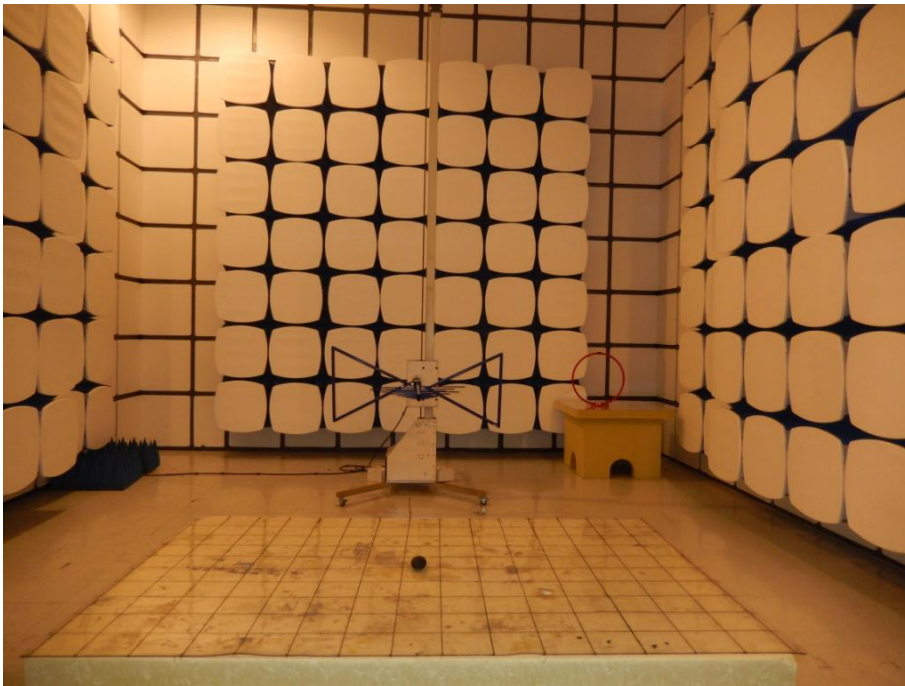

*****END OF THE REPORT*****