



# FCC RADIO TEST REPORT

Applicant : Intracom Asia Co., Ltd.

---

Address : 4F., No.77, Sec. 1, Xintai 5th Rd., Xizhi Dist., New Taipei City 221, Taiwan

---

Equipment : 300N High-Power PoE Access Point

---

Model No. : 525800

---

Trade Name : Intellinet

---

FCC ID : 2ADQY-525800

---

### I HEREBY CERTIFY THAT :

The sample was received on Jun. 01, 2016 and the testing was carried out on Jun. 13, 2016 at CerpPASS Technology Corp. The test result refers exclusively to the test presented test model / sample. Without written approval of CerpPASS Technology Corp., the test report shall not be reproduced except in full.

Approved by:

Ray Chou

Assistant Manager

### Laboratory Accreditation:

CerpPASS Technology Corporation Test Laboratory

<b>NVLAP LAB Code:</b>	<b>200954-0</b>
<b>TAF LAB Code:</b>	<b>1439</b>

CerpPASS Technology(SuZhou) Co., Ltd.

<b>NVLAP LAB Code:</b>	<b>200814-0</b>
<b>CNAS LAB Code:</b>	<b>L5515</b>



## CONTENTS<sub>s</sub>

<b>1. Summary of Test Procedure and Test Results</b> .....	<b>5</b>
1.1 Applicable Standards.....	5
<b>2. Test Configuration of Equipment under Test</b> .....	<b>6</b>
2.1 Feature of Equipment under Test.....	6
2.2 Carrier Frequency of Channels.....	6
2.3 Test Mode and Test Software.....	7
2.4 Description of Test System.....	7
2.5 General Information of Test.....	8
2.6 Measurement Uncertainty.....	9
2.7 Duty cycle.....	10
<b>3. Test Equipment and Ancillaries Used for Tests</b> .....	<b>11</b>
<b>4. Antenna Requirements</b> .....	<b>12</b>
4.1 Standard Applicable.....	12
4.2 Antenna Construction and Directional Gain.....	12
<b>5. Test of AC Power Line Conducted Emission</b> .....	<b>13</b>
5.1 Test Limit.....	13
5.2 Test Procedures.....	13
5.3 Typical Test Setup.....	13
5.4 Test Result and Data.....	14
<b>6. Test of Spurious Emission (Radiated)</b> .....	<b>16</b>
6.1 Test Limit.....	16
6.2 Test Procedures.....	16
6.3 Typical Test Setup.....	17
6.4 Test Result and Data (9KHz ~ 30MHz).....	19
6.5 Test Result and Data (30MHz ~ 1GHz).....	19
6.6 Test Result and Data (1GHz ~ 25GHz).....	20
6.7 Restricted Bands of Operation.....	50
6.8 Restrict Band Emission Measurement Data.....	51
<b>7. Test of Spurious Emission (Conducted)</b> .....	<b>61</b>
7.1 Test Limit.....	61
7.2 Test Procedure.....	61
7.3 Test Setup Layout.....	61
7.4 Test Result and Data.....	62
<b>8. 6dB Bandwidth Measurement Data</b> .....	<b>71</b>
8.1 Test Limit.....	71
8.2 Test Procedures.....	71
8.3 Test Setup Layout.....	71
8.4 Test Result and Data.....	71
<b>9. Maximum Peak Output Power</b> .....	<b>77</b>
9.1 Test Limit.....	77
9.2 Test Procedures.....	77
9.3 Test Setup Layout.....	77
9.4 Test Result and Data.....	78



**10. Power Spectral Density ..... 79**  
10.1 Test Limit ..... 79  
10.2 Test Procedures ..... 79  
10.3 Test Setup Layout..... 79  
10.4 Test Result and Data ..... 80



History of this test report

ORIGINAL

Additional attachment as following record:

Attachment No.	Issue Date	Description



# 1. Summary of Test Procedure and Test Results

## 1.1 Applicable Standards

ANSI C63.10: 2013

KDB 558074 D01 DTS Meas Guidance v03r05

FCC Rules and Regulations Part 15 Subpart C §15.247

FCC Rule	Description of Test	Result
FCC CFR Title 47 Part 15 Subpart C: Section 15.203/15.247 (b)	. Antenna Requirement	Pass
FCC CFR Title 47 Part 15 Subpart C: Section 15.207	. AC Power Line Conducted Emission	Pass
FCC CFR Title 47 Part 15 Subpart C: Section 15.205/15.209; Part2 section 2.1051, 2.1053, 2.1057	. Spurious Emission(Radiated)	Pass
FCC CFR Title 47 Part 15 Subpart C: Section 15.247(d); Part2 section 2.1051 and 2.1057	. Spurious Emission(Conducted)	Pass
FCC CFR Title 47 Part 15 Subpart C: Section 15.247(a)(2); Part2 section 2.1049	. 6dB Bandwidth	Pass
FCC CFR Title 47 Part 15 Subpart C: Section 15.247(b); Part2 section 2.1046	. Maximum Peak Output Power	Pass
FCC CFR Title 47 Part 15 Subpart C: Section 15.247(e)	. Power Spectral Density	Pass



## 2. Test Configuration of Equipment under Test

### 2.1 Feature of Equipment under Test

Equipment	300N High-Power PoE Access Point
Model No.	525800
Spreading	802.11b: CCK, DQPSK, DBPSK 802.11g: 64 QAM, 16 QAM, QPSK, BPSK 802.11n: BPSK, QPSK, 16QAM, 64QAM
Frequency Range	802.11b/g/n(20MHz): 2412-2462MHz 802.11n(40MHz): 2422-2452MHz
Number of Channels	802.11b/g/n (20MHz):11 802.11n (40MHz): 7
Data Rate	802.11b: 1, 2, 5.5, 11Mbps 802.11g: 6, 9, 12, 18, 24, 36, 48, 54Mbps 802.11n: Up to 300Mbps
Antenna Type	Dipole Antenna 3dBi

### 2.2 Carrier Frequency of Channels

802.11b, 802.11g, 802.11n HT 20 (2412MHz~2462MHz)

Channel	Frequency(MHz)	Channel	Frequency(MHz)
<b>*01</b>	<b>2412</b>	07	2442
02	2417	08	2447
03	2422	09	2452
04	2427	10	2457
05	2432	<b>*11</b>	<b>2462</b>
<b>*06</b>	<b>2437</b>	---	---

802.11an HT40(2422-2452MHz)

Channel	Frequency(MHz)	Channel	Frequency(MHz)
---	---	07	2442
---	---	08	2447
<b>*03</b>	<b>2422</b>	<b>*09</b>	<b>2452</b>
04	2427	---	---
05	2432	---	---
<b>*06</b>	<b>2437</b>	---	---

Note: Channels remarked \* are selected to perform test.



### 2.3 Test Mode and Test Software

- a. During testing, the interface cables and equipment positions were varied according to ANSI C63.4.
- b. The complete test system included Notebook, Mouse and EUT for the RF test.
- c. An executive program, "artgui.exe" which transmits and receives data through Wireless.
- d. The EUT had been tested under operating condition  
After verification, all tests were carried out with the worst case test modes as shown below except radiated spurious emission below 1GHz and power line conducted emissions below 30MHz, which worst case was in normal link mode only.  
EUT staying in continuous transmitting mode was programmed.
- e. Test modes:
  - Mode 1: IEEE 802.11b(Antenna 1)
  - Mode 2: IEEE 802.11g(Antenna 1)
  - Mode 3: IEEE 802.11n HT20(Antenna 1)
  - Mode 4: IEEE 802.11n HT40(Antenna 1)
  - Mode 5: IEEE 802.11b(Antenna 2)
  - Mode 6: IEEE 802.11g(Antenna 2)
  - Mode 7: IEEE 802.11n HT20(Antenna 2)
  - Mode 8: IEEE 802.11n HT40(Antenna 2)
  - Mode 9: IEEE 802.11n HT20 (Antenna 1+2)
  - Mode 10: IEEE 802.11n HT40(Antenna 1+2)

### 2.4 Description of Test System

No	Device	Manufacturer	Model No.	Description
1	USB Mouse	DELL	OXN967	R41108
2	Notebook	SONY	PCG-71811P	R33021

#### Use Cable:

No.	Cable	Quantity	Description
A	RJ45 Cable	1	1.5m Non Shielding
B	DC Cable	1	1.5m Non Shielding
C	USB Mouse Cable	1	1.5m Non Shielding



## 2.5 General Information of Test

<input checked="" type="checkbox"/>	Test Site	<b>CerpPASS Technology Corporation Test Laboratory</b> Address: No.10, Ln. 2, Lianfu St., Luzhu Dist., Taoyuan City 33848, Taiwan (R.O.C.) Tel:+886-3-3226-888 Fax:+886-3-3226-881 Address: No.68-1, Shihbachongsi, Shihding Township, New Taipei City 223, Taiwan, R.O.C. Tel: +886-2-2663-8582
	FCC	TW1079, TW1061,390316, 228391, 641184
	IC	4934B-1, 4934E-1, 4934E-2
	VCCI	T-2205 for Telecommunication Test C-4663 for Conducted emission test R-3428, R-4218 for Radiated emission test G-812, G-813 for radiated disturbance above 1GHz
<input type="checkbox"/>	Test Site	<b>CerpPASS Technology (Suzhou) Co.,Ltd</b> Address: No.66,Tangzhuang Road, Suzhou Industrial Park, Jiangsu 215006, China Tel: +86-512-6917-5888 Fax: +86-512-6917-5666
	FCC	916572, 331395
	IC	7290A-1, 7290A-2
	VCCI	T-343 for Telecommunication Test C-2919 for Conducted emission test R-2670 for Radiated emission test G-227 for radiated disturbance above 1GHz
Frequency Range Investigated:		Conducted: from 150kHz to 30 MHz Radiation: from 30 MHz to 25000MHz
Test Distance:		The test distance of radiated emission from antenna to EUT is 3 M.





### 2.6 Measurement Uncertainty

Measurement Item	Measurement Frequency	Polarization	Uncertainty
Conducted Emission	9 kHz ~ 30 MHz	LINE/NEUTRAL	±2.71 dB
Radiated Emission	9 kHz ~ 30 MHz	Vertical	±3.65dB
		Horizontal	±3.89dB
Radiated Emission	30 MHz ~ 25GHz	Vertical	±4.11 dB
		Horizontal	±4.10 dB
Occupied Bandwidth	---	---	±7500 Hz
Maximum Peak Output Power	---	---	±1.4 dB
Power Spectral Density	---	---	±2.2 dB



### 2.7 Duty cycle

Test Item	Duty cycle
Test Date	2016-06-15

Mode	Frequency (MHz)	Measurement (%)
802.11b	2412	99.5
802.11g	2412	95.8
802.11n(20MHz)	2412	95.5
802.11n(40MHz)	2412	94.0

Transmit at channel 1 by 802.11b

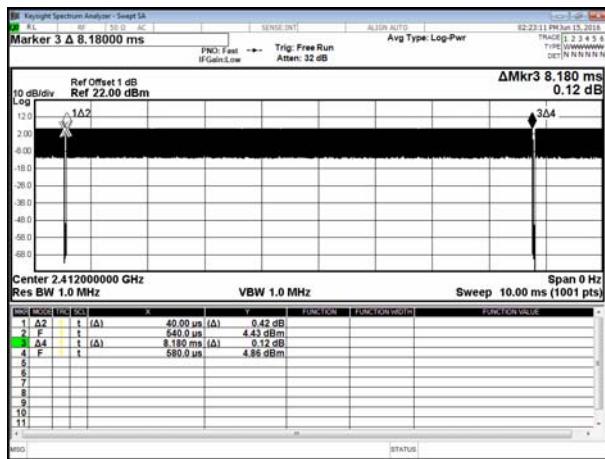

Transmit at channel 1 by 802.11g

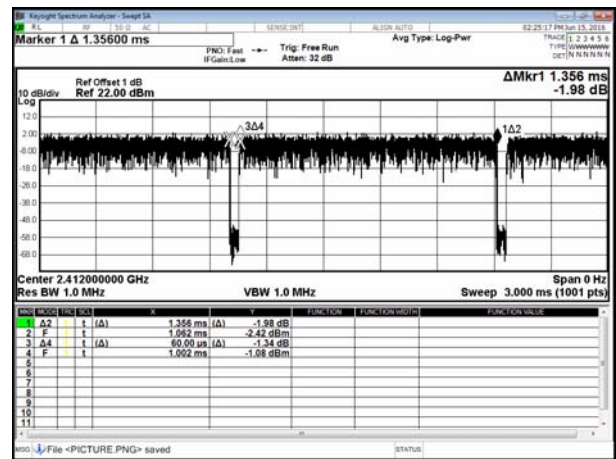

Transmit at channel 1 by 802.11n(20MHz)

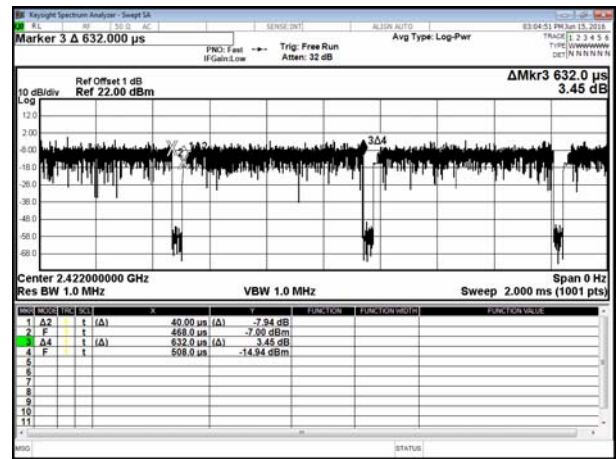
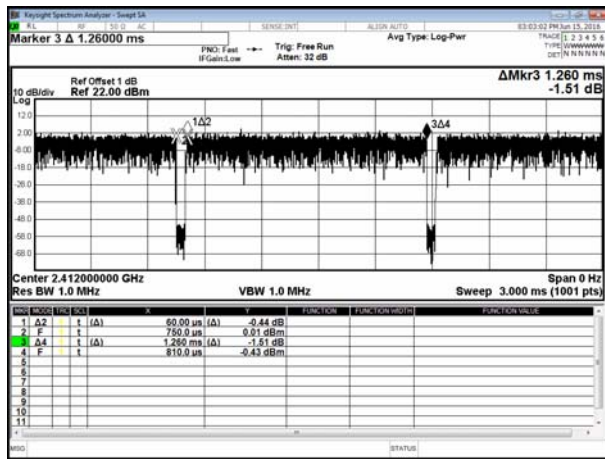



### 3. Test Equipment and Ancillaries Used for Tests

Instrument	Manufacturer	Model No.	Serial No.	Calibration Date	Valid Date
Test Receiver	R&S	ESCI	100564	2016.02.22	2017.02.21
LISN	SCHWARZBECK	NSLK 8127	8127748	2015.10.22	2016.10.21
LISN	SCHWARZBECK	NSLK 8127	8127749	2015.10.22	2016.10.21
Pulse Limiter with 10dB Attenuation	SCHWARZBECK	VTSD 9561-F	9561-F106	2016.02.22	2017.02.21
Temperature/ Humidity Meter	mingle	ETH529	N/A	2016.02.22	2017.02.21
AMPLIFIER	HP	8447F	3113A05915	2016.02.22	2017.02.21
Loop Antenna	R&S	HFH2-Z2	100150	2016.04.16	2017.04.15
BILOG Antenna	SCHAFFNER	CBL6112D	22241	2016.02.24	2017.02.23
Horn Antenna	Sunol	DRH-118	A072913	2015.09.30	2016.09.29
Broad-Band Horn Antenna	Schwarzbeck	BBHA9170	9170-347	2016.04.16	2017.04.15
Preamplifier	COM-POWER	PA-840	711885	2016.03.26	2017.03.25
Temp&Humidity&barometer	mingle	ETH529	N/A	2016.02.19	2017.02.18
Preamplifier	Field	AFS44-0010180 0-25- 10P-44	1579008	2015.09.30	2016.09.29
ESG VECTOR SIGNAL GENERATOR	Agilent	E4438C	MY4509258 2	2016.06.06	2017.06.05
MXG VECTOR SIGNAL GENERATOR	Agilent	N5182B	MY5305012 7	2016.06.06	2017.06.05
EXA Signal Analyzer	Agilent	N9020A	US46220290	2016.06.06	2017.06.05
Power sensor	e-channel	ERS-180T-24	TW5451026	2016.06.25	2017.06.24
Series Power Meter	ANRITSU	ML24958A	1224005	2016.03.27	2016.03.26



## 4. Antenna Requirements

### 4.1 Standard Applicable

For intentional device, according to FCC 47 CFR Section 15.203, an intentional radiator shall be designed to ensure that no antenna other than that furnished by the responsible party shall be used with the device.

And according to FCC 47 CFR Section 15.247 (b), if transmitting antennas of directional gain greater than 6dBi are used, the power shall be reduced by the amount in dB that the directional gain of the antenna exceeds 6dBi.

### 4.2 Antenna Construction and Directional Gain

No.	Antenna Type	Antenna Gain
1	Dipole Antenna	3dBi



## 5. Test of AC Power Line Conducted Emission

### 5.1 Test Limit

Conducted Emissions were measured from 150 kHz to 30 MHz with a bandwidth of 9 KHz on the 120 VAC power and return leads of the EUT according to the methods defined in ANSI C63.10-2013. The EUT was placed on a nonmetallic stand in a shielded room 0.8 meters above the ground plane as shown in section 6.2.2. The interface cables and equipment positioning were varied within limits of reasonable applications to determine the position produced maximum conducted emissions.

Frequency (MHz)	Quasi Peak (dB $\mu$ V)	Average (dB $\mu$ V)
0.15 – 0.5	66-56*	56-46*
0.5 – 5.0	56	46
5.0 – 30.0	60	50

\*Decreases with the logarithm of the frequency.

### 5.2 Test Procedures

The EUT was setup according to ANSI C63.10, 2013 and tested according to DTS test procedure of Oct 2014 KDB558074 for compliance to FCC 47CFR 15.247 requirements. The EUT was placed on a platform of nominal size, 1 m by 1.5 m, raised 80 cm above the conducting ground plane. The vertical conducting plane was located 40 cm to the rear of the EUT. All other surfaces of EUT were at least 80 cm from any other grounded conducting surface. The EUT and simulators are connected to the main power through a line impedance stabilization network (LISN). The LISN provides a 50 ohm /50uH coupling impedance for the measuring equipment. The peripheral devices are also connected to the main power through a LISN. (Please refer to the block diagram of the test setup and photographs) Each current-carrying conductor of the EUT power cord, except the ground (safety) conductor, was individually connected through a LISN to the input power source. The excess length of the power cord between the EUT and the LISN receptacle were folded back and forth at the center of the lead to form a bundle not exceeding 40 cm in length. Conducted emissions were investigated over the frequency range from 0.15MHz to 30MHz using a receiver bandwidth of 9kHz.

### 5.3 Typical Test Setup

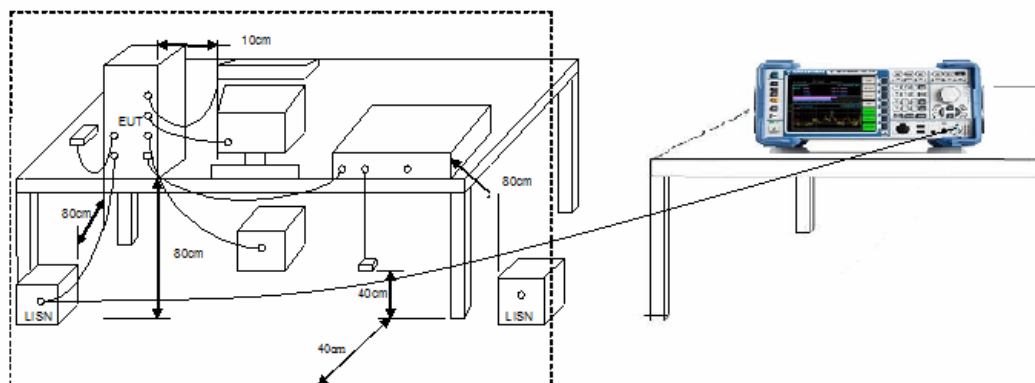



5.4 Test Result and Data

Test Mode :	Normal Link	Phase :	Line
Temperature :	20°C	Humidity:	51%
Pressur(mbar) :	1002	Date:	2016/06/13

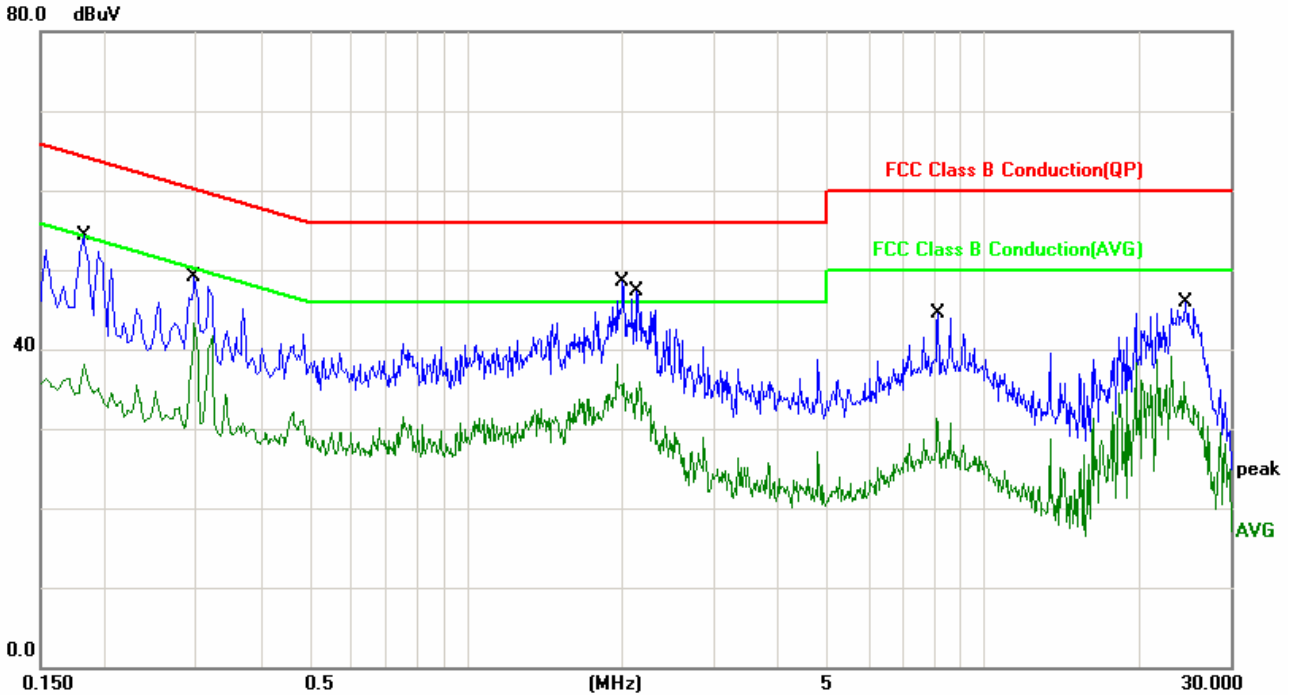

No.	Frequency (MHz)	Factor (dB)	Reading (dBuV)	Level (dBuV)	Limit (dBuV)	Margin (dB)	Detector
1	0.1819	11.73	34.99	46.72	64.39	-17.67	QP
2	0.1819	11.73	22.67	34.40	54.39	-19.99	AVG
3	0.2980	10.75	35.57	46.32	60.30	-13.98	QP
4	0.2980	10.75	31.28	42.03	50.30	-8.27	AVG
5	2.0020	11.03	29.08	40.11	56.00	-15.89	QP
6	2.0020	11.03	20.74	31.77	46.00	-14.23	AVG
7	2.1420	11.00	29.07	40.07	56.00	-15.93	QP
8	2.1420	11.00	21.13	32.13	46.00	-13.87	AVG
9	8.1500	10.35	29.64	39.99	60.00	-20.01	QP
10	8.1500	10.35	19.72	30.07	50.00	-19.93	AVG
11	24.5340	10.49	28.71	39.20	60.00	-20.80	QP
12	24.5340	10.49	22.72	33.21	50.00	-16.79	AVG

Note: Measurement Level = Reading Level + Correct Factor+ Attenuator



Test Mode :	Normal Link	Phase :	Neutral
Temperature :	20°C	Humidity :	51%
Pressur(mbar) :	1002	Date :	2016/06/13

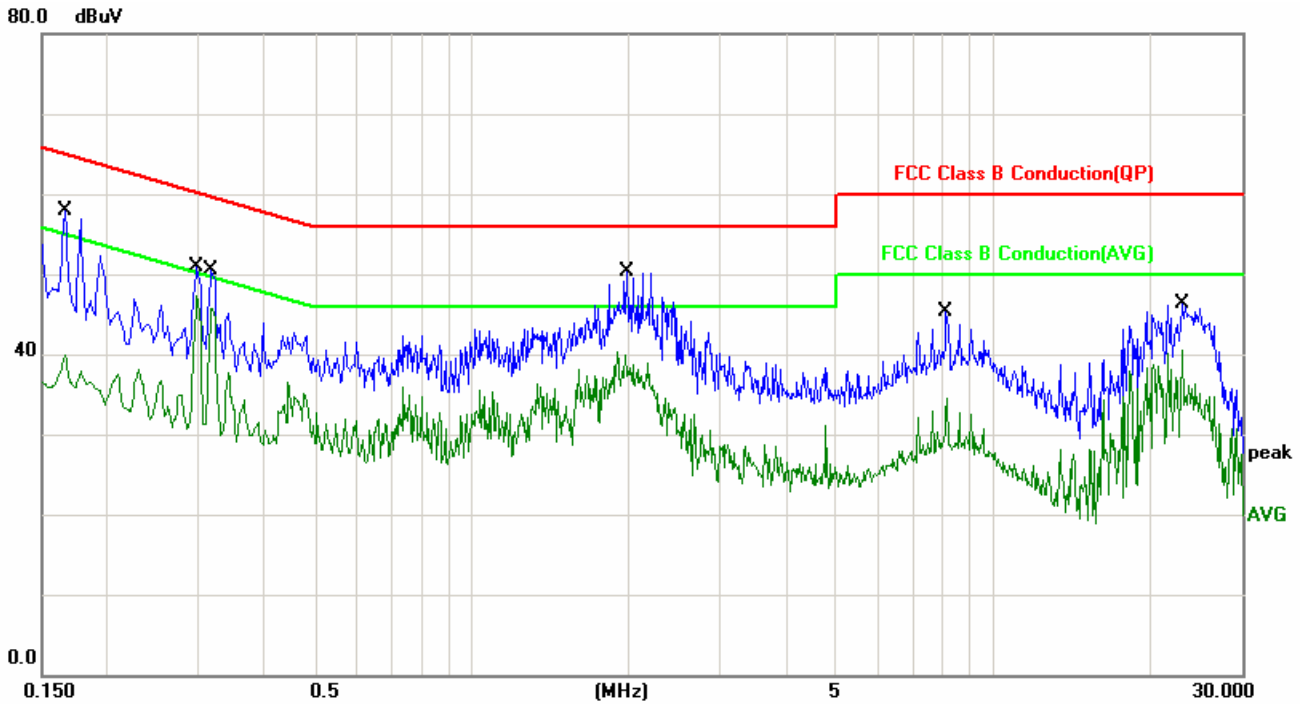

No.	Frequency (MHz)	Factor (dB)	Reading (dBuV)	Level (dBuV)	Limit (dBuV)	Margin (dB)	Detector
1	0.1660	12.72	30.55	43.27	65.15	-21.88	QP
2	0.1660	12.72	23.07	35.79	55.15	-19.36	AVG
3	0.2980	10.76	38.38	49.14	60.30	-11.16	QP
4	0.2980	10.76	35.72	46.48	50.30	-3.82	AVG
5	0.3180	10.72	37.90	48.62	59.76	-11.14	QP
6	0.3180	10.72	34.85	45.57	49.76	-4.19	AVG
7	1.9900	10.28	33.28	43.56	56.00	-12.44	QP
8	1.9900	10.28	27.72	38.00	46.00	-8.00	AVG
9	8.1459	10.35	32.72	43.07	60.00	-16.93	QP
10	8.1459	10.35	24.52	34.87	50.00	-15.13	AVG
11	23.1299	10.50	34.00	44.50	60.00	-15.50	QP
12	23.1299	10.50	30.10	40.60	50.00	-9.40	AVG

Note: Measurement Level = Reading Level + Correct Factor+ Attenuator



## 6. Test of Spurious Emission (Radiated)

### 6.1 Test Limit

In any 100kHz bandwidth outside the frequency band in which the spread spectrum or digitally modulated intentional radiator is operating, the radio frequency power that is produced by the intentional radiator shall be at least 20dB below that in the 100kHz bandwidth within the band that contains the highest level of the desired power, based on either an RF conducted or a radiated measurement. If the transmitter measurement is based on the maximum conducted output power, the attenuation required under this paragraph shall be 30dB instead of 20dB. In addition, radiated emissions which fall in section 15.205(a) the restricted bands must also comply with the radiated emission limit specified in section 15.209(a).

FREQUENCIES(MHz)	FIELD STRENGTH (microvolts/meter)	MEASUREMENT DISTANCE(meters)
0.009~0.490	2400/F(kHz)	300
0.490~1.705	24000/F(kHz)	30
1.705~30.0	30	30
30~88	100	3
88~216	150	3
216~960	200	3
Above 960	500	3

### 6.2 Test Procedures

KDB 558074 D01v03r02 - Section 12.2.3 (quasi-peak measurements)

KDB 558074 D01v03r02 - Section 12.2.4 (peak power measurements)

KDB 558074 D01v03r02 - Section 12.2.5 (average power measurements)

#### Peak Field Strength Measurements

1. Analyzer center frequency was set to the frequency of the radiated spurious emission of interest
2. RBW = as specified in Table 1
3. VBW = 3MHz
4. Detector = peak
5. Sweep time = auto couple
6. Trace mode = max hold
7. Trace was allowed to stabilize

RBW as a function of frequency

Frequency	RBW
9-150 kHz	200-300 Hz
0.15-30 MHz	9-10 kHz
30-1000 MHz	100-120 kHz
> 1000 MHz	1 MHz





### Average Field Strength Measurements

1. Analyzer center frequency was set to the frequency of the radiated spurious emission of interest
2. RBW = 1MHz
3. VBW  $\geq 1/T$
4. De As an alternative, the instrument may be set to linear detector mode. Ensure that video filtering is applied in linear voltage domain (rather than in a log or dB domain). Some instruments require linear display mode in order to accomplish this. Others have a setting for Average-VBW Type, which can be set to "Voltage" regardless of the display mode
5. Detector = Peak
6. Sweep time = auto
7. Trace mode = max hold
8. Allow max hold to run for at least 50 times (1/duty cycle) traces

### 6.3 Typical Test Setup

Below 30MHz test setup

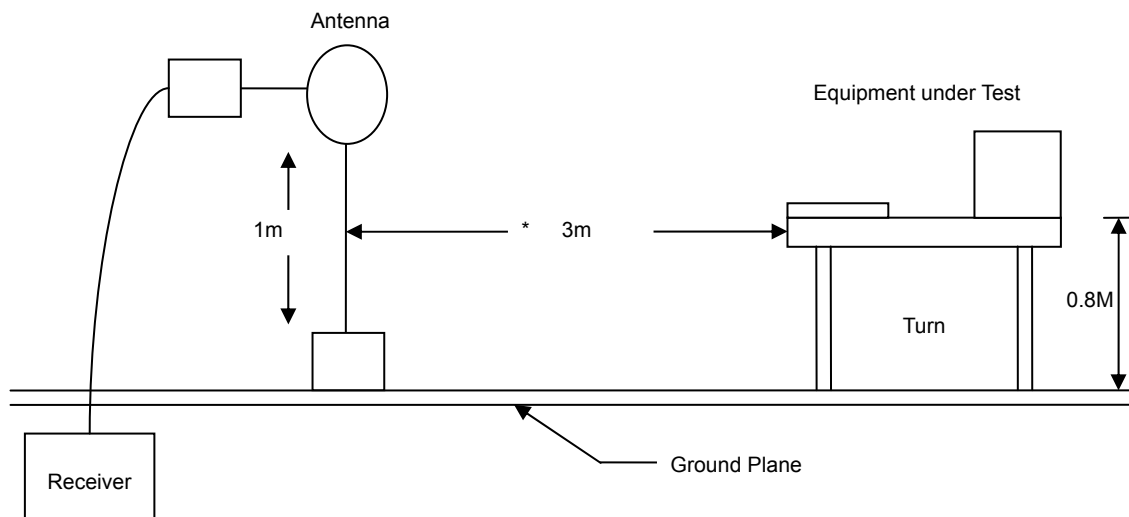

30MHz- 1GHz Test Setup

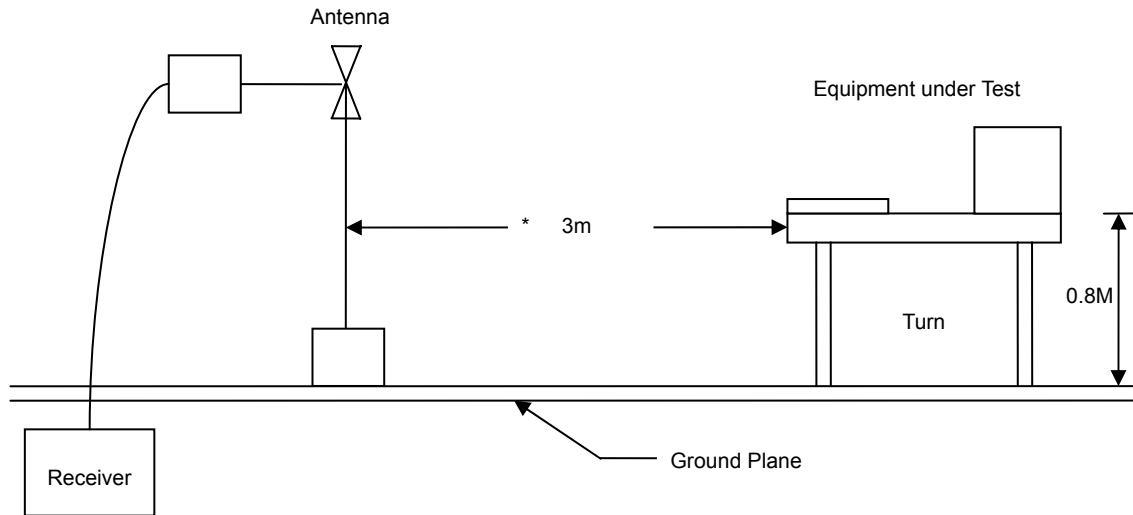

Above 1GHz Test Setup

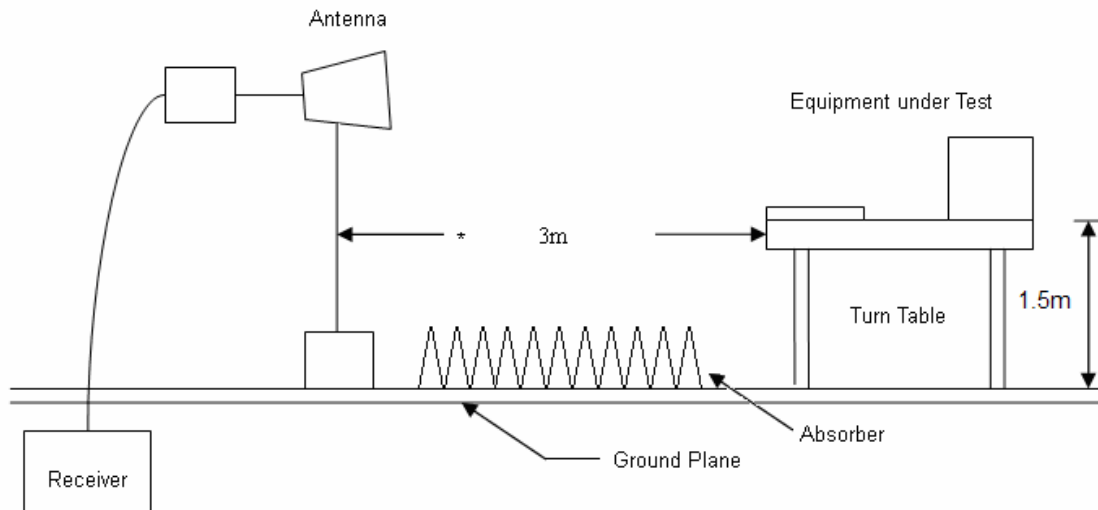

**6.4 Test Result and Data (9KHz ~ 30MHz)**

The 9kHz-30MHz spurious emission is under limit 20dB more.

**6.5 Test Result and Data (30MHz ~ 1GHz)**

Power	: AC 120V	Temperature	: 24 °C
Test Mode	: Normal Link	Humidity	: 54 %
Test date	: Jun. 12, 2016	Atmospheric Pressure	: 1010 hpa

Frequency (MHz)	AntPol. H/V	Correct Factor (dB)	Reading level (dBuV)	Measure Level (dBuV/m)	Limit 3m (dBuV/m)	Safe Margin (dB)	Detector mode (PK/QP)
101.7800	H	-9.46	42.06	32.60	43.50	-10.90	QP
206.5399	H	-9.51	41.17	31.66	43.50	-11.84	QP
275.4100	H	-8.94	46.79	37.85	46.00	-8.15	QP
346.2200	H	-4.26	42.06	37.80	46.00	-8.20	QP
400.5400	H	-5.13	44.15	39.02	46.00	-6.98	QP
436.4300	H	-4.27	39.16	34.89	46.00	-11.11	QP
43.5800	V	-11.77	45.38	33.61	40.00	-6.39	QP
53.2800	V	-14.73	48.87	34.14	40.00	-5.86	QP
90.1400	V	-11.37	44.49	33.12	43.50	-10.38	QP
108.5700	V	-8.72	43.58	34.86	43.50	-8.64	QP
155.1300	V	-11.69	46.34	34.65	43.50	-8.85	QP
275.4100	V	-8.94	41.27	32.33	46.00	-13.67	QP

Note: Level = Reading + Factor

Margin = Level – Limit

Factor= Antenna Factor + Cable Loss - Amplifier Factor

**6.6 Test Result and Data (1GHz ~ 25GHz)**

Power	: AC 120V	Temperature	: 24 °C
Test Mode1	802.11b (2412MHz) Ant1	Humidity	: 54 %
Test date	: Jun. 12, 2016	Atmospheric Pressure	: 1010 hpa

Frequency (MHz)	AntPol. H/V	Correct Factor (dB)	Reading level (dBuV)	Measure Level (dBuV/m)	Limit 3m (dBuV/m)	Safe Margin (dB)	Detector mode (PK/AV)
1127.500	H	-11.01	52.34	41.33	74.00	-32.67	peak
1552.500	H	-7.31	49.48	42.17	74.00	-31.83	peak
2955.000	H	0.47	40.92	41.39	74.00	-32.61	peak
4825.000	H	8.27	50.38	58.65	74.00	-15.35	peak
4825.000	H	8.27	40.21	48.48	54.00	-5.52	AVG
6907.500	H	11.78	34.86	46.64	74.00	-27.36	peak
8735.000	H	16.27	32.25	48.52	74.00	-25.48	peak
1127.500	V	-11.01	56.52	45.51	74.00	-28.49	peak
1595.000	V	-7.06	49.33	42.27	74.00	-31.73	peak
2232.500	V	-3.73	46.14	42.41	74.00	-31.59	peak
3210.000	V	1.87	40.07	41.94	74.00	-32.06	peak
4825.000	V	8.27	44.62	52.89	74.00	-21.11	peak
7970.000	V	14.26	34.43	48.69	74.00	-25.31	peak

Note: Level = Reading + Factor

Margin = Level – Limit

Factor= Antenna Factor + Cable Loss - Amplifier Factor



Power	: AC 120V	Temperature	: 24 °C
Test Mode1	802.11b (2437MHz) Ant1	Humidity	: 54 %
Test date	: Jun. 12, 2016	Atmospheric Pressure	: 1010 hpa

Frequency (MHz)	AntPol. H/V	Correct Factor (dB)	Reading level (dBuV)	Measure Level (dBuV/m)	Limit 3m (dBuV/m)	Safe Margin (dB)	Detector mode (PK/AV)
1127.500	H	-11.01	53.58	42.57	74.00	-31.43	peak
1510.000	H	-7.55	47.19	39.64	74.00	-34.36	peak
4527.500	H	7.71	32.73	40.44	74.00	-33.56	peak
4910.000	H	8.43	44.89	53.32	74.00	-20.68	peak
6950.000	H	11.92	32.23	44.15	74.00	-29.85	peak
7332.500	H	13.38	32.85	46.23	74.00	-27.77	peak
1127.500	V	-11.01	54.89	43.88	74.00	-30.12	peak
1595.000	V	-7.06	50.01	42.95	74.00	-31.05	peak
2232.500	V	-3.73	45.15	41.42	74.00	-32.58	peak
3210.000	V	1.87	41.26	43.13	74.00	-30.87	peak
4102.500	V	5.63	35.53	41.16	74.00	-32.84	peak
4910.000	V	8.43	40.46	48.89	74.00	-25.11	peak

Note: Level = Reading + Factor

Margin = Level – Limit

Factor= Antenna Factor + Cable Loss - Amplifier Factor



Power	: AC 120V	Temperature	: 24 °C
Test Mode1	802.11b (2462MHz) Ant1	Humidity	: 54 %
Test date	: Jun. 12, 2016	Atmospheric Pressure	: 1010 hpa

Frequency (MHz)	AntPol. H/V	Correct Factor (dB)	Reading level (dBuV)	Measure Level (dBuV/m)	Limit 3m (dBuV/m)	Safe Margin (dB)	Detector mode (PK/AV)
1127.500	H	-11.01	53.91	42.90	74.00	-31.10	peak
1510.000	H	-7.55	49.83	42.28	74.00	-31.72	peak
2955.000	H	0.47	41.44	41.91	74.00	-32.09	peak
4527.500	H	7.71	33.13	40.84	74.00	-33.16	peak
4952.500	H	8.51	42.21	50.72	74.00	-23.28	peak
6950.000	H	11.92	32.07	43.99	74.00	-30.01	peak
1127.500	V	-11.01	55.08	44.07	74.00	-29.93	peak
1765.000	V	-6.08	56.75	50.67	74.00	-23.33	peak
2232.500	V	-3.73	45.65	41.92	74.00	-32.08	peak
2955.000	V	0.47	40.89	41.36	74.00	-32.64	peak
4952.500	V	8.51	36.75	45.26	74.00	-28.74	peak
7375.000	V	13.54	34.08	47.62	74.00	-26.38	peak

Note: Level = Reading + Factor

Margin = Level – Limit

Factor= Antenna Factor + Cable Loss - Amplifier Factor



Power	: AC 120V	Temperature	: 24 °C
Test Mode2	802.11g (2412MHz) Ant1	Humidity	: 54 %
Test date	: Jun. 12, 2016	Atmospheric Pressure	: 1010 hpa

Frequency (MHz)	AntPol. H/V	Correct Factor (dB)	Reading level (dBuV)	Measure Level (dBuV/m)	Limit 3m (dBuV/m)	Safe Margin (dB)	Detector mode (PK/AV)
1340.000	H	-9.07	49.51	40.44	74.00	-33.56	peak
2955.000	H	0.47	41.32	41.79	74.00	-32.21	peak
4315.000	H	6.72	32.68	39.40	74.00	-34.60	peak
4867.500	H	8.35	42.07	50.42	74.00	-23.58	peak
6057.500	H	10.28	31.74	42.02	74.00	-31.98	peak
7247.500	H	13.05	31.83	44.88	74.00	-29.12	peak
1127.500	V	-11.01	48.06	37.05	74.00	-36.95	peak
1552.500	V	-7.31	45.38	38.07	74.00	-35.93	peak
2870.000	V	-0.10	39.86	39.76	74.00	-34.24	peak
4442.500	V	7.37	30.85	38.22	74.00	-35.78	peak
5590.000	V	9.24	29.71	38.95	74.00	-35.05	peak
7247.500	V	13.05	29.61	42.66	74.00	-31.34	peak

Note: Level = Reading + Factor

Margin = Level – Limit

Factor= Antenna Factor + Cable Loss - Amplifier Factor



Power	: AC 120V	Temperature	: 24 °C
Test Mode2	802.11g (2437MHz) Ant1	Humidity	: 54 %
Test date	: Jun. 12, 2016	Atmospheric Pressure	: 1010 hpa

Frequency (MHz)	AntPol. H/V	Correct Factor (dB)	Reading level (dBuV)	Measure Level (dBuV/m)	Limit 3m (dBuV/m)	Safe Margin (dB)	Detector mode (PK/AV)
1510.000	H	-7.55	49.86	42.31	74.00	-31.69	peak
4017.500	H	5.20	34.47	39.67	74.00	-34.33	peak
4910.000	H	8.43	39.25	47.68	74.00	-26.32	peak
6185.000	H	10.33	31.56	41.89	74.00	-32.11	peak
7077.500	H	12.38	31.89	44.27	74.00	-29.73	peak
7672.500	H	14.11	33.14	47.25	74.00	-26.75	peak
1127.500	V	-11.01	53.11	42.10	74.00	-31.90	peak
1552.500	V	-7.31	50.51	43.20	74.00	-30.80	peak
2955.000	V	0.47	41.20	41.67	74.00	-32.33	peak
4867.500	V	8.35	34.34	42.69	74.00	-31.31	peak
6822.500	V	11.50	31.81	43.31	74.00	-30.69	peak
7332.500	V	13.38	32.71	46.09	74.00	-27.91	peak

Note: Level = Reading + Factor

Margin = Level – Limit

Factor= Antenna Factor + Cable Loss - Amplifier Factor





Power	: AC 120V	Temperature	: 24 °C
Test Mode2	802.11g (2462MHz) Ant1	Humidity	: 54 %
Test date	: Jun. 12, 2016	Atmospheric Pressure	: 1010 hpa

Frequency (MHz)	AntPol. H/V	Correct Factor (dB)	Reading level (dBuV)	Measure Level (dBuV/m)	Limit 3m (dBuV/m)	Safe Margin (dB)	Detector mode (PK/AV)
1127.500	H	-11.01	51.78	40.77	74.00	-33.23	peak
1510.000	H	-7.55	49.21	41.66	74.00	-32.34	peak
3210.000	H	1.87	37.40	39.27	74.00	-34.73	peak
4952.500	H	8.51	36.52	45.03	74.00	-28.97	peak
6015.000	H	10.27	31.65	41.92	74.00	-32.08	peak
7077.500	H	12.38	32.78	45.16	74.00	-28.84	peak
1127.500	V	-11.01	54.06	43.05	74.00	-30.95	peak
1722.500	V	-6.33	49.69	43.36	74.00	-30.64	peak
2955.000	V	0.47	41.67	42.14	74.00	-31.86	peak
3210.000	V	1.87	39.73	41.60	74.00	-32.40	peak
5802.500	V	9.77	31.61	41.38	74.00	-32.62	peak
6270.000	V	10.37	32.36	42.73	74.00	-31.27	peak

Note: Level = Reading + Factor

Margin = Level – Limit

Factor= Antenna Factor + Cable Loss - Amplifier Factor



Power	: AC 120V	Temperature	: 24 °C
Test Mode3	802.11n HT20 (2412MHz) Ant1	Humidity	: 54 %
Test date	: Jun. 12, 2016	Atmospheric Pressure	: 1010 hpa

Frequency (MHz)	AntPol. H/V	Correct Factor (dB)	Reading level (dBuV)	Measure Level (dBuV/m)	Limit 3m (dBuV/m)	Safe Margin (dB)	Detector mode (PK/AV)
1127.500	H	-11.01	51.68	40.67	74.00	-33.33	peak
1552.500	H	-7.31	51.07	43.76	74.00	-30.24	peak
4442.500	H	7.37	32.73	40.10	74.00	-33.90	peak
4867.500	H	8.35	44.41	52.76	74.00	-21.24	peak
6270.000	H	10.37	31.83	42.20	74.00	-31.80	peak
7545.000	H	14.05	32.51	46.56	74.00	-27.44	peak
1127.500	V	-11.01	54.19	43.18	74.00	-30.82	peak
1552.500	V	-7.31	50.43	43.12	74.00	-30.88	peak
1892.500	V	-5.35	47.56	42.21	74.00	-31.79	peak
2955.000	V	0.47	41.94	42.41	74.00	-31.59	peak
4825.000	V	8.27	37.88	46.15	74.00	-27.85	peak
7545.000	V	14.05	32.69	46.74	74.00	-27.26	peak

Note: Level = Reading + Factor  
Margin = Level – Limit  
Factor= Antenna Factor + Cable Loss - Amplifier Factor



Power	: AC 120V	Temperature	: 24 °C
Test Mode3	802.11n HT20 (2437MHz) Ant1	Humidity	: 54 %
Test date	: Jun. 12, 2016	Atmospheric Pressure	: 1010 hpa

Frequency (MHz)	AntPol. H/V	Correct Factor (dB)	Reading level (dBuV)	Measure Level (dBuV/m)	Limit 3m (dBuV/m)	Safe Margin (dB)	Detector mode (PK/AV)
1127.500	H	-11.01	51.13	40.12	74.00	-33.88	peak
1552.500	H	-7.31	49.06	41.75	74.00	-32.25	peak
2955.000	H	0.47	41.20	41.67	74.00	-32.33	peak
4527.500	H	7.71	34.08	41.79	74.00	-32.21	peak
4910.000	H	8.43	37.60	46.03	74.00	-27.97	peak
7332.500	H	13.38	32.81	46.19	74.00	-27.81	peak
1127.500	V	-11.01	52.87	41.86	74.00	-32.14	peak
1552.500	V	-7.31	48.67	41.36	74.00	-32.64	peak
2232.500	V	-3.73	44.79	41.06	74.00	-32.94	peak
2955.000	V	0.47	41.35	41.82	74.00	-32.18	peak
4867.500	V	8.35	34.14	42.49	74.00	-31.51	peak
7375.000	V	13.54	32.81	46.35	74.00	-27.65	peak

Note: Level = Reading + Factor  
Margin = Level – Limit  
Factor= Antenna Factor + Cable Loss - Amplifier Factor



Power	: AC 120V	Temperature	: 24 °C
Test Mode3	802.11n HT20 (2462MHz) Ant1	Humidity	: 54 %
Test date	: Jun. 12, 2016	Atmospheric Pressure	: 1010 hpa

Frequency (MHz)	AntPol. H/V	Correct Factor (dB)	Reading level (dBuV)	Measure Level (dBuV/m)	Limit 3m (dBuV/m)	Safe Margin (dB)	Detector mode (PK/AV)
1127.500	H	-11.01	51.70	40.69	74.00	-33.31	peak
1552.500	H	-7.31	48.31	41.00	74.00	-33.00	peak
2870.000	H	-0.10	41.34	41.24	74.00	-32.76	peak
4527.500	H	7.71	34.42	42.13	74.00	-31.87	peak
4952.500	H	8.51	36.68	45.19	74.00	-28.81	peak
7332.500	H	13.38	33.56	46.94	74.00	-27.06	peak
1127.500	V	-11.01	54.47	43.46	74.00	-30.54	peak
1552.500	V	-7.31	51.35	44.04	74.00	-29.96	peak
2232.500	V	-3.73	45.38	41.65	74.00	-32.35	peak
2870.000	V	-0.10	42.11	42.01	74.00	-31.99	peak
5887.500	V	9.98	32.07	42.05	74.00	-31.95	peak
7205.000	V	12.88	33.65	46.53	74.00	-27.47	peak

Note: Level = Reading + Factor

Margin = Level – Limit

Factor= Antenna Factor + Cable Loss - Amplifier Factor



Power	: AC 120V	Temperature	: 24 °C
Test Mode4	802.11n HT40 (2422MHz) Ant1	Humidity	: 54 %
Test date	: Jun. 12, 2016	Atmospheric Pressure	: 1010 hpa

Frequency (MHz)	AntPol. H/V	Correct Factor (dB)	Reading level (dBuV)	Measure Level (dBuV/m)	Limit 3m (dBuV/m)	Safe Margin (dB)	Detector mode (PK/AV)
1127.500	H	-11.01	50.22	39.21	74.00	-34.79	peak
1637.500	H	-6.82	45.22	38.40	74.00	-35.60	peak
2955.000	H	0.47	41.57	42.04	74.00	-31.96	peak
4867.500	H	8.35	38.82	47.17	74.00	-26.83	peak
6907.500	H	11.78	32.58	44.36	74.00	-29.64	peak
7545.000	H	14.05	32.28	46.33	74.00	-27.67	peak
1127.500	V	-11.01	54.11	43.10	74.00	-30.90	peak
1595.000	V	-7.06	48.87	41.81	74.00	-32.19	peak
2190.000	V	-3.91	46.46	42.55	74.00	-31.45	peak
3210.000	V	1.87	39.55	41.42	74.00	-32.58	peak
4867.500	V	8.35	33.90	42.25	74.00	-31.75	peak
7970.000	V	14.26	34.35	48.61	74.00	-25.39	peak

Note: Level = Reading + Factor  
 Margin = Level – Limit  
 Factor= Antenna Factor + Cable Loss - Amplifier Factor



Power	: AC 120V	Temperature	: 24 °C
Test Mode4	802.11n HT40 (2437MHz) Ant1	Humidity	: 54 %
Test date	: Jun. 12, 2016	Atmospheric Pressure	: 1010 hpa

Frequency (MHz)	AntPol. H/V	Correct Factor (dB)	Reading level (dBuV)	Measure Level (dBuV/m)	Limit 3m (dBuV/m)	Safe Margin (dB)	Detector mode (PK/AV)
1127.500	H	-11.01	50.52	39.51	74.00	-34.49	peak
1552.500	H	-7.31	47.70	40.39	74.00	-33.61	peak
2870.000	H	-0.10	41.73	41.63	74.00	-32.37	peak
4910.000	H	8.43	36.78	45.21	74.00	-28.79	peak
6015.000	H	10.27	31.54	41.81	74.00	-32.19	peak
7247.500	H	13.05	32.97	46.02	74.00	-27.98	peak
1127.500	V	-11.01	54.72	43.71	74.00	-30.29	peak
1552.500	V	-7.31	51.61	44.30	74.00	-29.70	peak
2955.000	V	0.47	41.13	41.60	74.00	-32.40	peak
4910.000	V	8.43	34.21	42.64	74.00	-31.36	peak
6270.000	V	10.37	31.67	42.04	74.00	-31.96	peak
7545.000	V	14.05	32.75	46.80	74.00	-27.20	peak

Note: Level = Reading + Factor  
 Margin = Level – Limit  
 Factor= Antenna Factor + Cable Loss - Amplifier Factor



Power	: AC 120V	Temperature	: 24 °C
Test Mode4	802.11n HT40 (2452MHz) Ant1	Humidity	: 54 %
Test date	: Jun. 12, 2016	Atmospheric Pressure	: 1010 hpa

Frequency (MHz)	AntPol. H/V	Correct Factor (dB)	Reading level (dBuV)	Measure Level (dBuV/m)	Limit 3m (dBuV/m)	Safe Margin (dB)	Detector mode (PK/AV)
1127.500	H	-11.01	52.78	41.77	74.00	-32.23	peak
1552.500	H	-7.31	47.95	40.64	74.00	-33.36	peak
2870.000	H	-0.10	41.98	41.88	74.00	-32.12	peak
4910.000	H	8.43	37.64	46.07	74.00	-27.93	peak
5802.500	H	9.77	31.84	41.61	74.00	-32.39	peak
7332.500	H	13.38	32.46	45.84	74.00	-28.16	peak
1127.500	V	-11.01	54.46	43.45	74.00	-30.55	peak
2232.500	V	-3.73	45.45	41.72	74.00	-32.28	peak
2955.000	V	0.47	41.66	42.13	74.00	-31.87	peak
5802.500	V	9.77	32.66	42.43	74.00	-31.57	peak
7630.000	V	14.09	32.54	46.63	74.00	-27.37	peak
7970.000	V	14.26	34.06	48.32	74.00	-25.68	peak

Note: Level = Reading + Factor

Margin = Level – Limit

Factor= Antenna Factor + Cable Loss - Amplifier Factor



Power	: AC 120V	Temperature	: 24 °C
Test Mode5	802.11b (2412MHz) Ant2	Humidity	: 54 %
Test date	: Jun. 12, 2016	Atmospheric Pressure	: 1010 hpa

Frequency (MHz)	AntPol. H/V	Correct Factor (dB)	Reading level (dBuV)	Measure Level (dBuV/m)	Limit 3m (dBuV/m)	Safe Margin (dB)	Detector mode (PK/AV)
1127.500	H	-11.01	52.70	41.69	74.00	-32.31	peak
1510.000	H	-7.55	47.47	39.92	74.00	-34.08	peak
2870.000	H	-0.10	42.14	42.04	74.00	-31.96	peak
4825.000	H	8.27	42.65	50.92	74.00	-23.08	peak
6397.500	H	10.42	31.89	42.31	74.00	-31.69	peak
7247.500	H	13.05	32.68	45.73	74.00	-28.27	peak
1127.500	V	-11.01	53.49	42.48	74.00	-31.52	peak
1552.500	V	-7.31	50.08	42.77	74.00	-31.23	peak
2190.000	V	-3.91	44.56	40.65	74.00	-33.35	peak
4825.000	V	8.27	38.12	46.39	74.00	-27.61	peak
5845.000	V	9.88	31.82	41.70	74.00	-32.30	peak
6865.000	V	11.64	32.89	44.53	74.00	-29.47	peak

Note: Level = Reading + Factor

Margin = Level – Limit

Factor= Antenna Factor + Cable Loss - Amplifier Factor





Power	: AC 120V	Temperature	: 24 °C
Test Mode5	802.11b (2437MHz) Ant2	Humidity	: 54 %
Test date	: Jun. 12, 2016	Atmospheric Pressure	: 1010 hpa

Frequency (MHz)	AntPol. H/V	Correct Factor (dB)	Reading level (dBuV)	Measure Level (dBuV/m)	Limit 3m (dBuV/m)	Safe Margin (dB)	Detector mode (PK/AV)
1127.500	H	-11.01	51.79	40.78	74.00	-33.22	peak
1552.500	H	-7.31	49.01	41.70	74.00	-32.30	peak
2955.000	H	0.47	41.25	41.72	74.00	-32.28	peak
4910.000	H	8.43	40.55	48.98	74.00	-25.02	peak
5760.000	H	9.66	32.40	42.06	74.00	-31.94	peak
6992.500	H	12.06	33.10	45.16	74.00	-28.84	peak
1127.500	V	-11.01	54.83	43.82	74.00	-30.18	peak
1595.000	V	-7.06	49.98	42.92	74.00	-31.08	peak
2190.000	V	-3.91	45.79	41.88	74.00	-32.12	peak
2870.000	V	-0.10	41.71	41.61	74.00	-32.39	peak
3210.000	V	1.87	40.10	41.97	74.00	-32.03	peak
4910.000	V	8.43	34.83	43.26	74.00	-30.74	peak

Note: Level = Reading + Factor

Margin = Level – Limit

Factor= Antenna Factor + Cable Loss - Amplifier Factor



Power	: AC 120V	Temperature	: 24 °C
Test Mode5	802.11b (2462MHz) Ant2	Humidity	: 54 %
Test date	: Jun. 12, 2016	Atmospheric Pressure	: 1010 hpa

Frequency (MHz)	AntPol. H/V	Correct Factor (dB)	Reading level (dBuV)	Measure Level (dBuV/m)	Limit 3m (dBuV/m)	Safe Margin (dB)	Detector mode (PK/AV)
1127.500	H	-11.01	50.60	39.59	74.00	-34.41	peak
1510.000	H	-7.55	47.44	39.89	74.00	-34.11	peak
2870.000	H	-0.10	41.34	41.24	74.00	-32.76	peak
4442.500	H	7.37	33.48	40.85	74.00	-33.15	peak
4952.500	H	8.51	41.05	49.56	74.00	-24.44	peak
6992.500	H	12.06	32.17	44.23	74.00	-29.77	peak
1127.500	V	-11.01	52.09	41.08	74.00	-32.92	peak
1552.500	V	-7.31	52.08	44.77	74.00	-29.23	peak
2190.000	V	-3.91	45.30	41.39	74.00	-32.61	peak
2955.000	V	0.47	41.35	41.82	74.00	-32.18	peak
4952.500	V	8.51	35.16	43.67	74.00	-30.33	peak
6950.000	V	11.92	32.25	44.17	74.00	-29.83	peak

Note: Level = Reading + Factor  
Margin = Level – Limit  
Factor= Antenna Factor + Cable Loss - Amplifier Factor



Power	: AC 120V	Temperature	: 24 °C
Test Mode6	802.11g (2412MHz) Ant2	Humidity	: 54 %
Test date	: Jun. 12, 2016	Atmospheric Pressure	: 1010 hpa

Frequency (MHz)	AntPol. H/V	Correct Factor (dB)	Reading level (dBuV)	Measure Level (dBuV/m)	Limit 3m (dBuV/m)	Safe Margin (dB)	Detector mode (PK/AV)
1127.500	H	-11.01	53.67	42.66	74.00	-31.34	peak
1552.500	H	-7.31	48.61	41.30	74.00	-32.70	peak
2955.000	H	0.47	40.96	41.43	74.00	-32.57	peak
4825.000	H	8.27	37.06	45.33	74.00	-28.67	peak
6822.500	H	11.50	32.00	43.50	74.00	-30.50	peak
7630.000	H	14.09	32.25	46.34	74.00	-27.66	peak
1127.500	V	-11.01	54.35	43.34	74.00	-30.66	peak
1552.500	V	-7.31	49.63	42.32	74.00	-31.68	peak
2955.000	V	0.47	41.22	41.69	74.00	-32.31	peak
3210.000	V	1.87	40.15	42.02	74.00	-31.98	peak
5590.000	V	9.24	31.73	40.97	74.00	-33.03	peak
6950.000	V	11.92	32.67	44.59	74.00	-29.41	peak

Note: Level = Reading + Factor

Margin = Level – Limit

Factor= Antenna Factor + Cable Loss - Amplifier Factor



Power	: AC 120V	Temperature	: 24 °C
Test Mode6	802.11g (2437MHz) Ant2	Humidity	: 54 %
Test date	: Jun. 12, 2016	Atmospheric Pressure	: 1010 hpa

Frequency (MHz)	AntPol. H/V	Correct Factor (dB)	Reading level (dBuV)	Measure Level (dBuV/m)	Limit 3m (dBuV/m)	Safe Margin (dB)	Detector mode (PK/AV)
1127.500	H	-11.01	51.99	40.98	74.00	-33.02	peak
1510.000	H	-7.55	48.35	40.80	74.00	-33.20	peak
2955.000	H	0.47	41.56	42.03	74.00	-31.97	peak
4910.000	H	8.43	34.04	42.47	74.00	-31.53	peak
6355.000	H	10.40	31.86	42.26	74.00	-31.74	peak
6950.000	H	11.92	32.34	44.26	74.00	-29.74	peak
1127.500	V	-11.01	55.24	44.23	74.00	-29.77	peak
1552.500	V	-7.31	48.51	41.20	74.00	-32.80	peak
2190.000	V	-3.91	44.77	40.86	74.00	-33.14	peak
3210.000	V	1.87	39.67	41.54	74.00	-32.46	peak
4867.500	V	8.35	32.96	41.31	74.00	-32.69	peak
7120.000	V	12.55	33.55	46.10	74.00	-27.90	peak

Note: Level = Reading + Factor

Margin = Level – Limit

Factor= Antenna Factor + Cable Loss - Amplifier Factor



Power	: AC 120V	Temperature	: 24 °C
Test Mode6	802.11g (2462MHz) Ant2	Humidity	: 54 %
Test date	: Jun. 12, 2016	Atmospheric Pressure	: 1010 hpa

Frequency (MHz)	AntPol. H/V	Correct Factor (dB)	Reading level (dBuV)	Measure Level (dBuV/m)	Limit 3m (dBuV/m)	Safe Margin (dB)	Detector mode (PK/AV)
1595.000	H	-7.06	47.57	40.51	74.00	-33.49	peak
1595.000	H	-7.06	47.57	40.51	74.00	-33.49	peak
2955.000	H	0.47	40.96	41.43	74.00	-32.57	peak
4612.500	H	7.87	32.92	40.79	74.00	-33.21	peak
5590.000	H	9.24	32.43	41.67	74.00	-32.33	peak
7290.000	H	13.21	33.90	47.11	74.00	-26.89	peak
1127.500	V	-11.01	54.20	43.19	74.00	-30.81	peak
1552.500	V	-7.31	53.53	46.22	74.00	-27.78	peak
2955.000	V	0.47	41.58	42.05	74.00	-31.95	peak
4527.500	V	7.71	33.48	41.19	74.00	-32.81	peak
6015.000	V	10.27	32.94	43.21	74.00	-30.79	peak
7332.500	V	13.38	33.10	46.48	74.00	-27.52	peak

Note: Level = Reading + Factor

Margin = Level – Limit

Factor= Antenna Factor + Cable Loss - Amplifier Factor



Power	: AC 120V	Temperature	: 24 °C
Test Mode7	802.11n HT20 (2412MHz) Ant2	Humidity	: 54 %
Test date	: Jun. 12, 2016	Atmospheric Pressure	: 1010 hpa

Frequency (MHz)	AntPol. H/V	Correct Factor (dB)	Reading level (dBuV)	Measure Level (dBuV/m)	Limit 3m (dBuV/m)	Safe Margin (dB)	Detector mode (PK/AV)
1127.500	H	-11.01	52.62	41.61	74.00	-32.39	peak
1552.500	H	-7.31	47.30	39.99	74.00	-34.01	peak
2870.000	H	-0.10	41.30	41.20	74.00	-32.80	peak
4867.500	H	8.35	37.07	45.42	74.00	-28.58	peak
6397.500	H	10.42	32.82	43.24	74.00	-30.76	peak
6865.000	H	11.64	32.84	44.48	74.00	-29.52	peak
1127.500	V	-11.01	53.37	42.36	74.00	-31.64	peak
1510.000	V	-7.55	51.01	43.46	74.00	-30.54	peak
2190.000	V	-3.91	46.94	43.03	74.00	-30.97	peak
2955.000	V	0.47	41.16	41.63	74.00	-32.37	peak
4952.500	V	8.51	32.56	41.07	74.00	-32.93	peak
7120.000	V	12.55	33.12	45.67	74.00	-28.33	peak

Note: Level = Reading + Factor  
 Margin = Level – Limit  
 Factor= Antenna Factor + Cable Loss - Amplifier Factor



Power	: AC 120V	Temperature	: 24 °C
Test Mode7	802.11n HT20 (2437MHz) Ant2	Humidity	: 54 %
Test date	: Jun. 12, 2016	Atmospheric Pressure	: 1010 hpa

Frequency (MHz)	AntPol. H/V	Correct Factor (dB)	Reading level (dBuV)	Measure Level (dBuV/m)	Limit 3m (dBuV/m)	Safe Margin (dB)	Detector mode (PK/AV)
1127.500	H	-11.01	50.19	39.18	74.00	-34.82	peak
1510.000	H	-7.55	47.26	39.71	74.00	-34.29	peak
4315.000	H	6.72	32.70	39.42	74.00	-34.58	peak
4910.000	H	8.43	34.55	42.98	74.00	-31.02	peak
6270.000	H	10.37	31.81	42.18	74.00	-31.82	peak
7077.500	H	12.38	33.74	46.12	74.00	-27.88	peak
1127.500	V	-11.01	53.45	42.44	74.00	-31.56	peak
1595.000	V	-7.06	48.69	41.63	74.00	-32.37	peak
2190.000	V	-3.91	45.00	41.09	74.00	-32.91	peak
2870.000	V	-0.10	42.06	41.96	74.00	-32.04	peak
3210.000	V	1.87	39.97	41.84	74.00	-32.16	peak
7120.000	V	12.55	32.58	45.13	74.00	-28.87	peak

Note: Level = Reading + Factor  
Margin = Level – Limit  
Factor= Antenna Factor + Cable Loss - Amplifier Factor



Power	: AC 120V	Temperature	: 24 °C
Test Mode7	802.11n HT20 (2462MHz) Ant2	Humidity	: 54 %
Test date	: Jun. 12, 2016	Atmospheric Pressure	: 1010 hpa

Frequency (MHz)	AntPol. H/V	Correct Factor (dB)	Reading level (dBuV)	Measure Level (dBuV/m)	Limit 3m (dBuV/m)	Safe Margin (dB)	Detector mode (PK/AV)
1510.000	H	-11.01	50.60	39.59	74.00	-34.41	peak
2232.500	H	-7.55	47.44	39.89	74.00	-34.11	peak
2700.000	H	-0.10	41.34	41.24	74.00	-32.76	peak
2955.000	H	7.37	33.48	40.85	74.00	-33.15	peak
4952.500	H	8.51	41.05	49.56	74.00	-24.44	peak
7290.000	H	12.06	32.17	44.23	74.00	-29.77	peak
1127.500	V	-11.01	54.32	43.31	74.00	-30.69	peak
1552.500	V	-7.31	48.60	41.29	74.00	-32.71	peak
1892.500	V	-5.35	45.97	40.62	74.00	-33.38	peak
2232.500	V	-3.73	48.13	44.40	74.00	-29.60	peak
4527.500	V	7.71	33.77	41.48	74.00	-32.52	peak
6907.500	V	11.78	33.48	45.26	74.00	-28.74	peak

Note: Level = Reading + Factor  
 Margin = Level – Limit  
 Factor= Antenna Factor + Cable Loss - Amplifier Factor





Power	: AC 120V	Temperature	: 24 °C
Test Mode8	802.11n HT40 (2422MHz) Ant2	Humidity	: 54 %
Test date	: Jun. 12, 2016	Atmospheric Pressure	: 1010 hpa

Frequency (MHz)	AntPol. H/V	Correct Factor (dB)	Reading level (dBuV)	Measure Level (dBuV/m)	Limit 3m (dBuV/m)	Safe Margin (dB)	Detector mode (PK/AV)
1127.500	H	-11.01	52.46	41.45	74.00	-32.55	peak
1510.000	H	-7.55	49.27	41.72	74.00	-32.28	peak
2955.000	H	0.47	41.45	41.92	74.00	-32.08	peak
4527.500	H	7.71	33.28	40.99	74.00	-33.01	peak
6227.500	H	10.35	32.33	42.68	74.00	-31.32	peak
7205.000	H	12.88	33.38	46.26	74.00	-27.74	peak
1127.500	V	-11.01	55.40	44.39	74.00	-29.61	peak
1552.500	V	-7.31	49.17	41.86	74.00	-32.14	peak
2190.000	V	-3.91	45.58	41.67	74.00	-32.33	peak
2955.000	V	0.47	41.20	41.67	74.00	-32.33	peak
4442.500	V	7.37	34.40	41.77	74.00	-32.23	peak
6907.500	V	11.78	33.00	44.78	74.00	-29.22	peak

Note: Level = Reading + Factor  
Margin = Level – Limit  
Factor= Antenna Factor + Cable Loss - Amplifier Factor



Power	: AC 120V	Temperature	: 24 °C
Test Mode8	802.11n HT40 (2437MHz) Ant2	Humidity	: 54 %
Test date	: Jun. 12, 2016	Atmospheric Pressure	: 1010 hpa

Frequency (MHz)	AntPol. H/V	Correct Factor (dB)	Reading level (dBuV)	Measure Level (dBuV/m)	Limit 3m (dBuV/m)	Safe Margin (dB)	Detector mode (PK/AV)
1552.500	H	-7.31	48.43	41.12	74.00	-32.88	peak
2955.000	H	0.47	40.48	40.95	74.00	-33.05	peak
4102.500	H	5.63	35.11	40.74	74.00	-33.26	peak
4910.000	H	8.43	34.10	42.53	74.00	-31.47	peak
6270.000	H	10.37	31.48	41.85	74.00	-32.15	peak
7375.000	H	13.54	33.59	47.13	74.00	-26.87	peak
1127.500	V	-11.01	55.18	44.17	74.00	-29.83	peak
1510.000	V	-7.55	49.50	41.95	74.00	-32.05	peak
2190.000	V	-3.91	46.87	42.96	74.00	-31.04	peak
3210.000	V	1.87	40.06	41.93	74.00	-32.07	peak
6227.500	V	10.35	31.95	42.30	74.00	-31.70	peak
6907.500	V	11.78	32.87	44.65	74.00	-29.35	peak

Note: Level = Reading + Factor  
Margin = Level – Limit  
Factor= Antenna Factor + Cable Loss - Amplifier Factor



Power	: AC 120V	Temperature	: 24 °C
Test Mode8	802.11n HT40 (2452MHz) Ant2	Humidity	: 54 %
Test date	: Jun. 12, 2016	Atmospheric Pressure	: 1010 hpa

Frequency (MHz)	AntPol. H/V	Correct Factor (dB)	Reading level (dBuV)	Measure Level (dBuV/m)	Limit 3m (dBuV/m)	Safe Margin (dB)	Detector mode (PK/AV)
1127.500	H	-11.01	52.46	41.45	74.00	-32.55	peak
1552.500	H	-7.31	47.35	40.04	74.00	-33.96	peak
2912.500	H	0.18	41.13	41.31	74.00	-32.69	peak
4952.500	H	8.51	34.50	43.01	74.00	-30.99	peak
6907.500	H	11.78	33.19	44.97	74.00	-29.03	peak
7630.000	H	14.09	32.67	46.76	74.00	-27.24	peak
1127.500	V	-11.01	54.00	42.99	74.00	-31.01	peak
1552.500	V	-7.31	49.16	41.85	74.00	-32.15	peak
2190.000	V	-3.91	45.71	41.80	74.00	-32.20	peak
5165.000	V	8.74	32.84	41.58	74.00	-32.42	peak
5802.500	V	9.77	32.43	42.20	74.00	-31.80	peak
7247.500	V	13.05	33.40	46.45	74.00	-27.55	peak

Note: Level = Reading + Factor  
Margin = Level – Limit  
Factor= Antenna Factor + Cable Loss - Amplifier Factor



Power	: AC 120V	Temperature	: 24 °C
Test Mode9	802.11n HT20 (2412MHz) Ant1+2	Humidity	: 54 %
Test date	: Jun. 12, 2016	Atmospheric Pressure	: 1010 hpa

Frequency (MHz)	AntPol. H/V	Correct Factor (dB)	Reading level (dBuV)	Measure Level (dBuV/m)	Limit 3m (dBuV/m)	Safe Margin (dB)	Detector mode (PK/AV)
1127.500	H	-11.01	52.31	41.30	74.00	-32.70	peak
1552.500	H	-7.31	49.49	42.18	74.00	-31.82	peak
1935.000	H	-5.10	44.81	39.71	74.00	-34.29	peak
2955.000	H	0.47	41.37	41.84	74.00	-32.16	peak
4867.500	H	8.35	42.18	50.53	74.00	-23.47	peak
6312.500	H	10.38	31.87	42.25	74.00	-31.75	peak
1127.500	V	-11.01	53.51	42.50	74.00	-31.50	peak
1595.000	V	-7.06	51.66	44.60	74.00	-29.40	peak
2190.000	V	-3.91	47.40	43.49	74.00	-30.51	peak
2955.000	V	0.47	40.96	41.43	74.00	-32.57	peak
4825.000	V	8.27	35.92	44.19	74.00	-29.81	peak
7247.500	V	13.05	32.98	46.03	74.00	-27.97	peak

Note: Level = Reading + Factor  
 Margin = Level – Limit  
 Factor= Antenna Factor + Cable Loss - Amplifier Factor



Power	: AC 120V	Temperature	: 24 °C
Test Mode9	802.11n HT20 (2437MHz) Ant1+2	Humidity	: 54 %
Test date	: Jun. 12, 2016	Atmospheric Pressure	: 1010 hpa

Frequency (MHz)	AntPol. H/V	Correct Factor (dB)	Reading level (dBuV)	Measure Level (dBuV/m)	Limit 3m (dBuV/m)	Safe Margin (dB)	Detector mode (PK/AV)
1127.500	H	-11.01	50.63	39.62	74.00	-34.38	peak
1552.500	H	-7.31	48.84	41.53	74.00	-32.47	peak
2232.500	H	-3.73	42.95	39.22	74.00	-34.78	peak
2955.000	H	0.47	40.69	41.16	74.00	-32.84	peak
4910.000	H	8.43	37.33	45.76	74.00	-28.24	peak
7247.500	H	13.05	34.08	47.13	74.00	-26.87	peak
1127.500	V	-11.01	55.50	44.49	74.00	-29.51	peak
1552.500	V	-7.31	50.38	43.07	74.00	-30.93	peak
2232.500	V	-3.73	46.44	42.71	74.00	-31.29	peak
2955.000	V	0.47	41.47	41.94	74.00	-32.06	peak
4102.500	V	5.63	37.44	43.07	74.00	-30.93	peak
7290.000	V	13.21	33.45	46.66	74.00	-27.34	peak

Note: Level = Reading + Factor  
 Margin = Level – Limit  
 Factor= Antenna Factor + Cable Loss - Amplifier Factor



Power	: AC 120V	Temperature	: 24 °C
Test Mode9	802.11n HT20 (2462MHz) Ant1+2	Humidity	: 54 %
Test date	: Jun. 12, 2016	Atmospheric Pressure	: 1010 hpa

Frequency (MHz)	AntPol. H/V	Correct Factor (dB)	Reading level (dBuV)	Measure Level (dBuV/m)	Limit 3m (dBuV/m)	Safe Margin (dB)	Detector mode (PK/AV)
1127.500	H	-11.01	50.91	39.90	74.00	-34.10	peak
1552.500	H	-7.31	47.05	39.74	74.00	-34.26	peak
2232.500	H	-3.73	44.30	40.57	74.00	-33.43	peak
2955.000	H	0.47	40.89	41.36	74.00	-32.64	peak
4952.500	H	8.51	35.57	44.08	74.00	-29.92	peak
7247.500	H	13.05	32.61	45.66	74.00	-28.34	peak
1127.500	V	-11.01	54.55	43.54	74.00	-30.46	peak
1552.500	V	-7.31	53.24	45.93	74.00	-28.07	peak
2232.500	V	-3.73	46.54	42.81	74.00	-31.19	peak
2955.000	V	0.47	42.32	42.79	74.00	-31.21	peak
5972.500	V	10.19	31.83	42.02	74.00	-31.98	peak
7970.000	V	14.26	34.12	48.38	74.00	-25.62	peak

Note: Level = Reading + Factor  
Margin = Level – Limit  
Factor= Antenna Factor + Cable Loss - Amplifier Factor



Power	: AC 120V	Temperature	: 24 °C
Test Mode10	802.11n HT40 (2422MHz) Ant1+2	Humidity	: 54 %
Test date	: Jun. 12, 2016	Atmospheric Pressure	: 1010 hpa

Frequency (MHz)	AntPol. H/V	Correct Factor (dB)	Reading level (dBuV)	Measure Level (dBuV/m)	Limit 3m (dBuV/m)	Safe Margin (dB)	Detector mode (PK/AV)
1510.000	H	-7.55	49.42	41.87	74.00	-32.13	peak
2232.500	H	-3.73	44.44	40.71	74.00	-33.29	peak
2955.000	H	0.47	41.04	41.51	74.00	-32.49	peak
4867.500	H	8.35	38.37	46.72	74.00	-27.28	peak
6227.500	H	10.35	32.16	42.51	74.00	-31.49	peak
7290.000	H	13.21	32.67	45.88	74.00	-28.12	peak
1127.500	V	-11.01	54.69	43.68	74.00	-30.32	peak
1637.500	V	-6.82	49.89	43.07	74.00	-30.93	peak
2190.000	V	-3.91	46.88	42.97	74.00	-31.03	peak
2955.000	V	0.47	41.42	41.89	74.00	-32.11	peak
4867.500	V	8.35	35.39	43.74	74.00	-30.26	peak
7290.000	V	13.21	32.79	46.00	74.00	-28.00	peak

Note: Level = Reading + Factor  
Margin = Level – Limit  
Factor= Antenna Factor + Cable Loss - Amplifier Factor



Power	: AC 120V	Temperature	: 24 °C
Test Mode10	802.11n HT40 (2437MHz) Ant1+2	Humidity	: 54 %
Test date	: Jun. 12, 2016	Atmospheric Pressure	: 1010 hpa

Frequency (MHz)	AntPol. H/V	Correct Factor (dB)	Reading level (dBuV)	Measure Level (dBuV/m)	Limit 3m (dBuV/m)	Safe Margin (dB)	Detector mode (PK/AV)
1127.500	H	-11.01	51.70	40.69	74.00	-33.31	peak
1637.500	H	-6.82	45.84	39.02	74.00	-34.98	peak
2232.500	H	-3.73	44.29	40.56	74.00	-33.44	peak
2955.000	H	0.47	42.41	42.88	74.00	-31.12	peak
4910.000	H	8.43	36.91	45.34	74.00	-28.66	peak
6057.500	H	10.28	31.92	42.20	74.00	-31.80	peak
1127.500	V	-11.01	56.75	45.74	74.00	-28.26	peak
1552.500	V	-7.31	50.31	43.00	74.00	-31.00	peak
2232.500	V	-3.73	47.79	44.06	74.00	-29.94	peak
2912.500	V	0.18	41.20	41.38	74.00	-32.62	peak
3210.000	V	1.87	37.87	39.74	74.00	-34.26	peak
4910.000	V	8.43	32.39	40.82	74.00	-33.18	peak

Note: Level = Reading + Factor  
Margin = Level – Limit  
Factor= Antenna Factor + Cable Loss - Amplifier Factor





Power	: AC 120V	Temperature	: 24 °C
Test Mode10	802.11n HT40 (2452MHz) Ant1+2	Humidity	: 54 %
Test date	: Jun. 12, 2016	Atmospheric Pressure	: 1010 hpa

Frequency (MHz)	AntPol. H/V	Correct Factor (dB)	Reading level (dBuV)	Measure Level (dBuV/m)	Limit 3m (dBuV/m)	Safe Margin (dB)	Detector mode (PK/AV)
1127.500	H	-11.01	52.14	41.13	74.00	-32.87	peak
1552.500	H	-7.31	49.44	42.13	74.00	-31.87	peak
2232.500	H	-3.73	45.93	42.20	74.00	-31.80	peak
2870.000	H	-0.10	41.87	41.77	74.00	-32.23	peak
4910.000	H	8.43	35.21	43.64	74.00	-30.36	peak
6397.500	H	10.42	32.10	42.52	74.00	-31.48	peak
1127.500	V	-11.01	56.44	45.43	74.00	-28.57	peak
1552.500	V	-7.31	50.66	43.35	74.00	-30.65	peak
2232.500	V	-3.73	46.38	42.65	74.00	-31.35	peak
2870.000	V	-0.10	41.39	41.29	74.00	-32.71	peak
3210.000	V	1.87	37.69	39.56	74.00	-34.44	peak
4612.500	V	7.87	32.58	40.45	74.00	-33.55	peak

Note: Level = Reading + Factor  
Margin = Level – Limit  
Factor= Antenna Factor + Cable Loss - Amplifier Factor



### 6.7 Restricted Bands of Operation

Only spurious emissions are permitted in any of the frequency bands listed below:

MHz	MHz	MHz	GHz
0.09000 – 0.11000	16.42000 – 16.42300	399.9 – 410.0	4.500 – 5.250
0.49500 – 0.505**	16.69475 – 16.69525	608.0 – 614.0	5.350 – 5.460
2.17350 – 2.19050	16.80425 – 16.80475	960.0 – 1240.0	7.250 – 7.750
4.12500 – 4.12800	25.50000 – 25.67000	1300.0 – 1427.0	8.025 – 8.500
4.17725 – 4.17775	37.50000 – 38.25000	1435.0 – 1626.5	9.000 – 9.200
4.20725 – 4.20775	73.00000 – 74.60000	1645.5 – 1646.5	9.300 – 9.500
6.21500 – 6.21800	74.80000 – 75.20000	1660.0 – 1710.0	10.600 – 12.700
6.26775 – 6.26825	108.00000 – 121.94000	1718.8 – 1722.2	13.250 – 13.400
6.31175 – 6.31225	123.00000 – 138.00000	2200.0 – 2300.0	14.470 – 14.500
8.29100 – 8.29400	149.90000 – 150.05000	2310.0 – 2390.0	15.350 – 16.200
8.36200 – 8.36600	156.52475 – 156.52525	2483.5 – 2500.0	17.700 – 21.400
8.37625 – 8.38675	156.70000 – 156.90000	2655.0 – 2900.0	22.010 – 23.120
8.41425 – 8.41475	162.01250 – 167.17000	3260.0 – 3267.0	23.600 – 24.000
12.29000 – 12.29300	167.72000 – 173.20000	3332.0 – 3339.0	31.200 – 31.800
12.51975 – 12.52025	240.00000 – 285.00000	3345.8 – 3358.0	36.430 – 36.500
12.57675 – 12.57725	322.00000 – 335.40000	3600.0 – 4400.0	Above 38.6
13.36000 – 13.41000			

\*\* : Until February 1, 1999, this restricted band shall be 0.490-0.510 MHz

**6.8 Restrict Band Emission Measurement Data**

Test Date: Jun. 14, 2016

Temperature: 26°C

Atmospheric pressure: 1018 hPa

Humidity: 47%

Modulation Standard: 802.11b Ant1

Channel 1				Fundamental Frequency: 2412 MHz			
Frequency (MHz)	Factor (dB/m)	Reading (dBuV)	Level (dBuV/m)	Limit (dBuV/m)	Margin (dB)	Det.	Ant-Pol H/V
2390.000	-3.05	53.15	50.10	74.00	-23.90	peak	H
2390.000	-3.05	38.73	35.68	54.00	-18.32	AVG	H
2390.000	-3.05	52.64	49.59	74.00	-24.41	peak	V
2390.000	-3.05	37.24	34.19	54.00	-19.81	AVG	V
Channel 11				Fundamental Frequency: 2462 MHz			
2483.500	-2.65	52.16	49.51	74.00	-24.49	peak	H
2483.500	-2.65	37.56	34.91	54.00	-19.09	AVG	H
2483.500	-2.65	51.70	49.05	74.00	-24.95	peak	V
2483.500	-2.65	37.22	34.57	54.00	-19.43	AVG	V

## Notes:

1. Result = Meter Reading + Factor
2. Factor = Antenna Factor + Cable Loss – Amplifier
3. The resolution bandwidth of test receiver/spectrum analyzer is 1MHz and video bandwidth is 3 MHz (detector peak mode) for Peak detection at frequency above 1GHz.
4. The resolution bandwidth of test receiver/spectrum analyzer is 1MHz and video bandwidth is 3 MHz (detector sample mode) for Average detection at frequency above 1GHz.



Test Date: Jun. 14, 2016

Temperature: 26°C

Atmospheric pressure: 1018 hPa

Humidity: 47%

Modulation Standard: 802.11g Ant1

Channel 1				Fundamental Frequency: 2412 MHz			
Frequency (MHz)	Factor (dB/m)	Reading (dBuV)	Level (dBuV/m)	Limit (dBuV/m)	Margin (dB)	Det.	Ant-Pol H/V
2390.000	-3.05	52.86	49.81	74.00	-24.19	peak	H
2390.000	-3.05	36.92	33.87	54.00	-20.13	AVG	H
2390.000	-3.05	52.65	49.60	74.00	-24.40	peak	V
2390.000	-3.05	37.88	34.83	54.00	-19.17	AVG	V
Channel 11				Fundamental Frequency: 2462 MHz			
2483.500	-2.65	51.72	49.07	74.00	-24.93	peak	H
2483.500	-2.65	36.59	33.94	54.00	-20.06	AVG	H
2483.500	-2.65	52.21	49.56	74.00	-24.44	peak	V
2483.500	-2.65	37.86	35.21	54.00	-18.79	AVG	V

Notes:

1. Result = Meter Reading + Factor
2. Factor = Antenna Factor + Cable Loss – Amplifier
3. The resolution bandwidth of test receiver/spectrum analyzer is 1MHz and video bandwidth is 3 MHz (detector peak mode) for Peak detection at frequency above 1GHz.
4. The resolution bandwidth of test receiver/spectrum analyzer is 1MHz and video bandwidth is 3 MHz (detector sample mode) for Average detection at frequency above 1GHz.



Test Date: Jun. 14, 2016

Temperature: 26°C

Atmospheric pressure: 1018 hPa

Humidity: 47%

Modulation Standard: 802.11n HT20 Ant1

Channel 1				Fundamental Frequency: 2412 MHz			
Frequency (MHz)	Factor (dB/m)	Reading (dBuV)	Level (dBuV/m)	Limit (dBuV/m)	Margin (dB)	Det.	Ant-Pol H/V
2390.000	-3.05	53.11	50.06	74.00	-23.94	peak	H
2390.000	-3.05	38.52	35.47	54.00	-18.53	AVG	H
2390.000	-3.05	54.16	51.11	74.00	-22.89	peak	V
2390.000	-3.05	39.75	36.70	54.00	-17.30	AVG	V
Channel 11				Fundamental Frequency: 2462 MHz			
2483.500	-2.65	52.46	49.81	74.00	-24.19	peak	H
2483.500	-2.65	36.78	34.13	54.00	-19.87	AVG	H
2483.500	-2.65	52.93	50.28	74.00	-23.72	peak	V
2483.500	-2.65	37.22	34.57	54.00	-19.43	AVG	V

Notes:

1. Result = Meter Reading + Factor
2. Factor = Antenna Factor + Cable Loss – Amplifier
3. The resolution bandwidth of test receiver/spectrum analyzer is 1MHz and video bandwidth is 3 MHz (detector peak mode) for Peak detection at frequency above 1GHz.
4. The resolution bandwidth of test receiver/spectrum analyzer is 1MHz and video bandwidth is 3 MHz (detector sample mode) for Average detection at frequency above 1GHz.



Test Date: Jun. 14, 2016

Temperature: 26°C

Atmospheric pressure: 1018 hPa

Humidity: 47%

Modulation Standard: 802.11n HT40 Ant1

Channel 3				Fundamental Frequency: 2422 MHz			
Frequency (MHz)	Factor (dB/m)	Reading (dBuV)	Level (dBuV/m)	Limit (dBuV/m)	Margin (dB)	Det.	Ant-Pol H/V
2390.000	-3.05	59.48	56.43	74.00	-17.57	peak	H
2390.000	-3.05	44.75	41.70	54.00	-12.30	AVG	H
2390.000	-3.05	58.23	55.18	74.00	-18.82	peak	V
2390.000	-3.05	43.19	40.14	54.00	-13.86	AVG	V
Channel 9				Fundamental Frequency: 2452 MHz			
2483.500	-2.65	58.89	56.24	74.00	-17.76	peak	H
2483.500	-2.65	44.12	41.47	54.00	-12.53	AVG	H
2483.500	-2.65	59.74	57.09	74.00	-16.91	peak	V
2483.500	-2.65	44.32	41.67	54.00	-12.33	AVG	V

Notes:

1. Result = Meter Reading + Factor
2. Factor = Antenna Factor + Cable Loss – Amplifier
3. The resolution bandwidth of test receiver/spectrum analyzer is 1MHz and video bandwidth is 3 MHz (detector peak mode) for Peak detection at frequency above 1GHz.
4. The resolution bandwidth of test receiver/spectrum analyzer is 1MHz and video bandwidth is 3 MHz (detector sample mode) for Average detection at frequency above 1GHz.



Test Date: Jun. 14, 2016

Temperature: 26°C

Atmospheric pressure: 1018 hPa

Humidity: 47%

Modulation Standard: 802.11b Ant2

Channel 1				Fundamental Frequency: 2412 MHz			
Frequency (MHz)	Factor (dB/m)	Reading (dBuV)	Level (dBuV/m)	Limit (dBuV/m)	Margin (dB)	Det.	Ant-Pol H/V
2390.000	-3.05	52.89	49.84	74.00	-24.16	peak	H
2390.000	-3.05	37.51	34.46	54.00	-19.54	AVG	H
2390.000	-3.05	53.31	50.26	74.00	-23.74	peak	V
2390.000	-3.05	38.92	35.87	54.00	-18.13	AVG	V
Channel 11				Fundamental Frequency: 2462 MHz			
2483.500	-2.65	52.08	49.43	74.00	-24.57	peak	H
2483.500	-2.65	37.54	34.89	54.00	-19.11	AVG	H
2483.500	-2.65	53.76	51.11	74.00	-22.89	peak	V
2483.500	-2.65	39.13	36.48	54.00	-17.52	AVG	V

Notes:

1. Result = Meter Reading + Factor
2. Factor = Antenna Factor + Cable Loss – Amplifier
3. The resolution bandwidth of test receiver/spectrum analyzer is 1MHz and video bandwidth is 3 MHz (detector peak mode) for Peak detection at frequency above 1GHz.
4. The resolution bandwidth of test receiver/spectrum analyzer is 1MHz and video bandwidth is 3 MHz (detector sample mode) for Average detection at frequency above 1GHz.



Test Date: Jun. 14, 2016

Temperature: 26°C

Atmospheric pressure: 1018 hPa

Humidity: 47%

Modulation Standard: 802.11g Ant2

Channel 1				Fundamental Frequency: 2412 MHz			
Frequency (MHz)	Factor (dB/m)	Reading (dBuV)	Level (dBuV/m)	Limit (dBuV/m)	Margin (dB)	Det.	Ant-Pol H/V
2390.000	-3.05	53.51	50.46	74.00	-23.54	peak	H
2390.000	-3.05	38.75	35.70	54.00	-18.30	AVG	H
2390.000	-3.05	53.60	50.55	74.00	-23.45	peak	V
2390.000	-3.05	38.46	35.41	54.00	-18.59	AVG	V
Channel 11				Fundamental Frequency: 2462 MHz			
2483.500	-2.65	51.75	49.10	74.00	-24.90	peak	H
2483.500	-2.65	35.46	32.81	54.00	-21.19	AVG	H
2483.500	-2.65	51.71	49.06	74.00	-24.94	peak	V
2483.500	-2.65	36.42	33.77	54.00	-20.23	AVG	V

Notes:

1. Result = Meter Reading + Factor
2. Factor = Antenna Factor + Cable Loss – Amplifier
3. The resolution bandwidth of test receiver/spectrum analyzer is 1MHz and video bandwidth is 3 MHz (detector peak mode) for Peak detection at frequency above 1GHz.
4. The resolution bandwidth of test receiver/spectrum analyzer is 1MHz and video bandwidth is 3 MHz (detector sample mode) for Average detection at frequency above 1GHz.





Test Date: Jun. 14, 2016

Temperature: 26°C

Atmospheric pressure: 1018 hPa

Humidity: 47%

Modulation Standard: 802.11n HT20 Ant2

Channel 1				Fundamental Frequency: 2412 MHz			
Frequency (MHz)	Factor (dB/m)	Reading (dBuV)	Level (dBuV/m)	Limit (dBuV/m)	Margin (dB)	Det.	Ant-Pol H/V
2390.000	-3.05	52.59	49.54	74.00	-24.46	peak	H
2390.000	-3.05	37.86	34.81	54.00	-19.19	AVG	H
2390.000	-3.05	52.95	49.90	74.00	-24.10	peak	V
2390.000	-3.05	36.74	33.69	54.00	-20.31	AVG	V
Channel 11				Fundamental Frequency: 2462 MHz			
2483.500	-2.65	51.00	48.35	74.00	-25.65	peak	H
2483.500	-2.65	35.76	33.11	54.00	-20.89	AVG	H
2483.500	-2.65	51.55	48.90	74.00	-25.10	peak	V
2483.500	-2.65	35.67	33.02	54.00	-20.98	AVG	V

Notes:

1. Result = Meter Reading + Factor
2. Factor = Antenna Factor + Cable Loss – Amplifier
3. The resolution bandwidth of test receiver/spectrum analyzer is 1MHz and video bandwidth is 3 MHz (detector peak mode) for Peak detection at frequency above 1GHz.
4. The resolution bandwidth of test receiver/spectrum analyzer is 1MHz and video bandwidth is 3 MHz (detector sample mode) for Average detection at frequency above 1GHz.



Test Date: Jun. 14, 2016

Temperature: 26°C

Atmospheric pressure: 1018 hPa

Humidity: 47%

Modulation Standard: 802.11n HT40 Ant2

Channel 3				Fundamental Frequency: 2422 MHz			
Frequency (MHz)	Factor (dB/m)	Reading (dBuV)	Level (dBuV/m)	Limit (dBuV/m)	Margin (dB)	Det.	Ant-Pol H/V
2483.500	-2.65	57.66	55.01	74.00	-18.99	peak	H
2483.500	-2.65	43.13	40.48	54.00	-13.52	AVG	H
2390.000	-3.05	59.52	56.47	74.00	-17.53	peak	V
2390.000	-3.05	44.31	41.26	54.00	-12.74	AVG	V
Channel 9				Fundamental Frequency: 2452 MHz			
2483.500	-2.65	57.03	54.38	74.00	-19.62	peak	H
2483.500	-2.65	42.51	39.86	54.00	-14.14	AVG	H
2483.500	-2.65	57.66	55.01	74.00	-18.99	peak	V
2483.500	-2.65	43.13	40.48	54.00	-13.52	AVG	V

Notes:

1. Result = Meter Reading + Factor
2. Factor = Antenna Factor + Cable Loss – Amplifier
3. The resolution bandwidth of test receiver/spectrum analyzer is 1MHz and video bandwidth is 3 MHz (detector peak mode) for Peak detection at frequency above 1GHz.
4. The resolution bandwidth of test receiver/spectrum analyzer is 1MHz and video bandwidth is 3 MHz (detector sample mode) for Average detection at frequency above 1GHz.



Test Date: Jun. 14, 2016

Temperature: 26°C

Atmospheric pressure: 1018 hPa

Humidity: 47%

Modulation Standard: 802.11n HT20 Ant1+2

Channel 1				Fundamental Frequency: 2412 MHz			
Frequency (MHz)	Factor (dB/m)	Reading (dBuV)	Level (dBuV/m)	Limit (dBuV/m)	Margin (dB)	Det.	Ant-Pol H/V
2483.500	-2.65	52.10	49.45	74.00	-24.55	peak	H
2483.500	-2.65	37.26	34.61	54.00	-19.39	AVG	H
2390.000	-3.05	54.33	51.28	74.00	-22.72	peak	V
2390.000	-3.05	40.02	36.97	54.00	-17.03	AVG	V
Channel 11				Fundamental Frequency: 2462 MHz			
2483.500	-2.65	52.10	49.45	74.00	-24.55	peak	H
2483.500	-2.65	37.26	34.61	54.00	-19.39	AVG	H
2483.500	-2.65	52.59	49.94	74.00	-24.06	peak	V
2483.500	-2.65	37.52	34.87	54.00	-19.13	AVG	V

Notes:

1. Result = Meter Reading + Factor
2. Factor = Antenna Factor + Cable Loss – Amplifier
3. The resolution bandwidth of test receiver/spectrum analyzer is 1MHz and video bandwidth is 3 MHz (detector peak mode) for Peak detection at frequency above 1GHz.
4. The resolution bandwidth of test receiver/spectrum analyzer is 1MHz and video bandwidth is 3 MHz (detector sample mode) for Average detection at frequency above 1GHz.



Test Date: Jun. 14, 2016

Temperature: 26°C

Atmospheric pressure: 1018 hPa

Humidity: 47%

Modulation Standard: 802.11n HT40 Ant1+2

Channel 3				Fundamental Frequency: 2422 MHz			
Frequency (MHz)	Factor (dB/m)	Reading (dBuV)	Level (dBuV/m)	Limit (dBuV/m)	Margin (dB)	Det.	Ant-Pol H/V
2390.000	-3.05	58.18	55.13	74.00	-18.87	peak	H
2390.000	-3.05	43.26	40.21	54.00	-13.79	AVG	H
2390.000	-3.05	60.74	57.69	74.00	-16.31	peak	V
2390.000	-3.05	45.32	42.27	54.00	-11.73	AVG	V
Channel 9				Fundamental Frequency: 2452 MHz			
2483.500	-2.65	58.42	55.77	74.00	-18.23	peak	H
2483.500	-2.65	43.51	40.86	54.00	-13.14	AVG	H
2483.500	-2.65	59.16	56.51	74.00	-17.49	peak	V
2483.580	-2.65	45.26	42.61	54.00	-11.39	AVG	V

Notes:

1. Result = Meter Reading + Factor
2. Factor = Antenna Factor + Cable Loss – Amplifier
3. The resolution bandwidth of test receiver/spectrum analyzer is 1MHz and video bandwidth is 3 MHz (detector peak mode) for Peak detection at frequency above 1GHz.
4. The resolution bandwidth of test receiver/spectrum analyzer is 1MHz and video bandwidth is 3 MHz (detector sample mode) for Average detection at frequency above 1GHz.



## 7. Test of Spurious Emission (Conducted)

### 7.1 Test Limit

Below 30dB of the highest emission level of operating band (In 100 kHz Resolution Bandwidth)

### 7.2 Test Procedure

KDB 558074 D01v03r02 - Section 11.2 & Section 11.3

#### 1. Reference level measurement

- (a) Set instrument center frequency to DTS channel center frequency
- (b) Set the span to  $\geq 1.5$  times the DTS bandwidth
- (c) Set the RBW = 100 kHz
- (d) Set the VBW  $\geq 3 \times$  RBW
- (e) Detector = peak
- (f) Sweep time = auto couple
- (g) Trace mode = max hold
- (h) Allow trace to fully stabilize

#### 2. Emission level measurement

- (a) Set the center frequency and span to encompass frequency range to be measured
- (b) RBW = 100kHz
- (c) VBW = 300kHz
- (d) Detector = Peak
- (e) Trace mode = max hold
- (f) Sweep time = auto couple
- (g) The trace was allowed to stabilize

### 7.3 Test Setup Layout

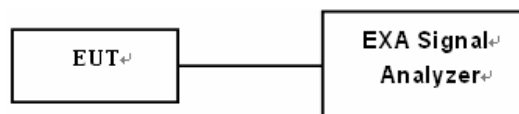



### 7.4 Test Result and Data

Test Date: Jun. 12, 2016

Temperature: 24°C

Atmospheric pressure: 1014 hPa

Humidity: 47%

Modulation Standard	Frequency (MHz)	Test Result
802.11b	2412	Pass
	2437	Pass
	2462	Pass
802.11g	2412	Pass
	2437	Pass
	2462	Pass
802.11n HT20	2412	Pass
	2437	Pass
	2462	Pass
802.11n HT40	2422	Pass
	2437	Pass
	2452	Pass

**Note:** Test plots refer to the following pages.



Antenna 1  
Modulation Type: 802.11b  
CH01

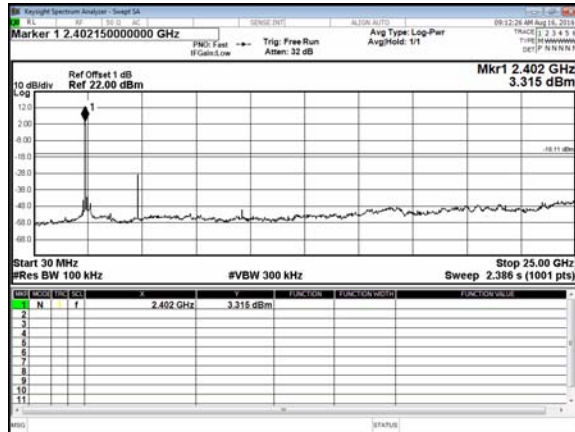
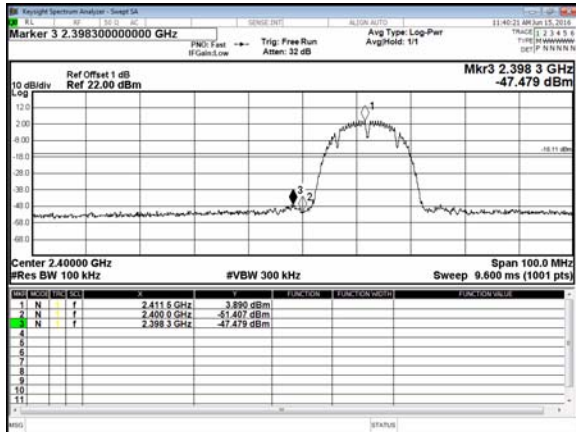

CH06

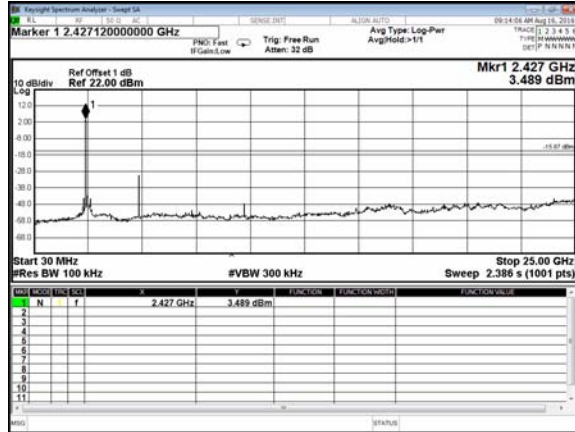
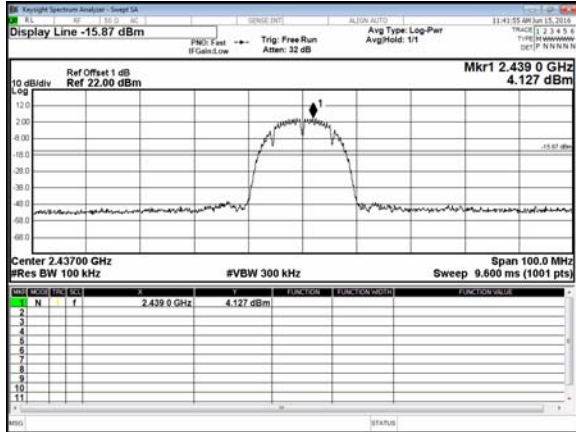

CH11

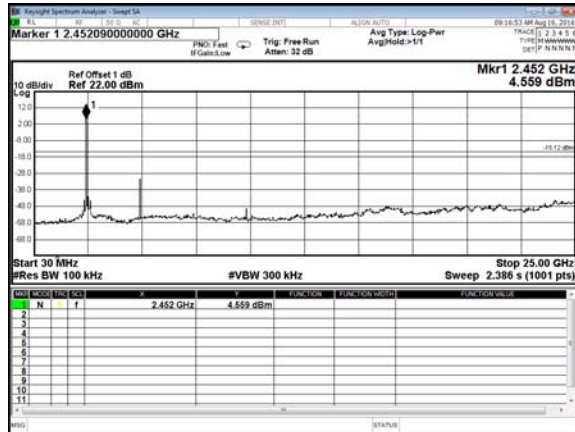
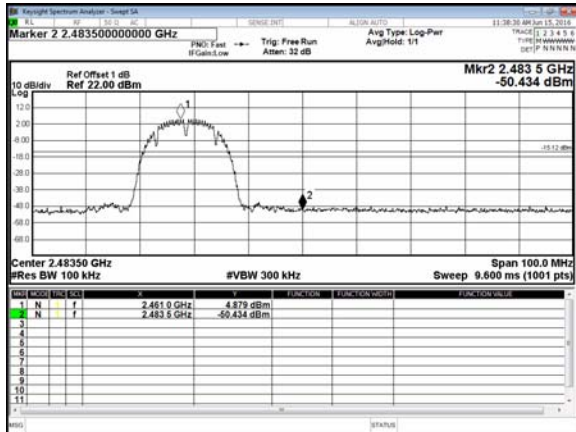



Modulation Type: 802.11g  
CH01

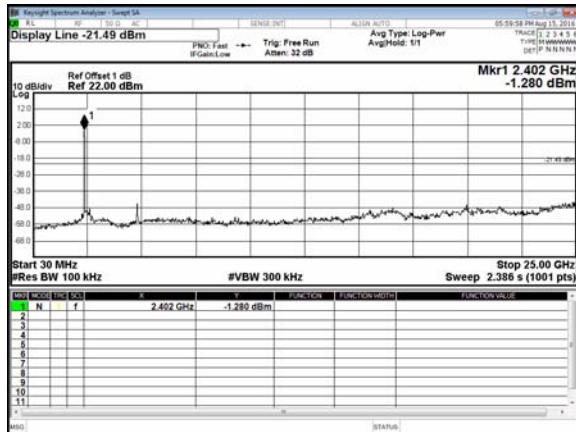
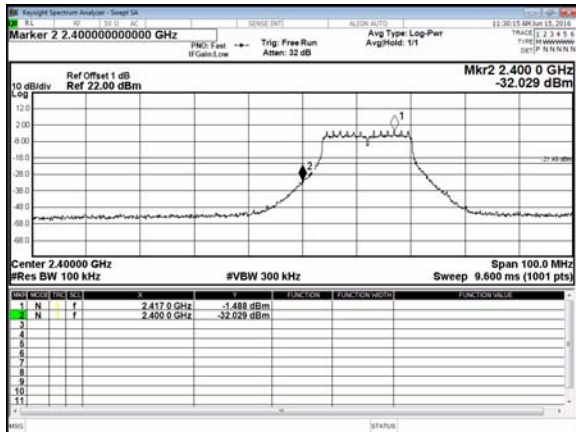

CH06

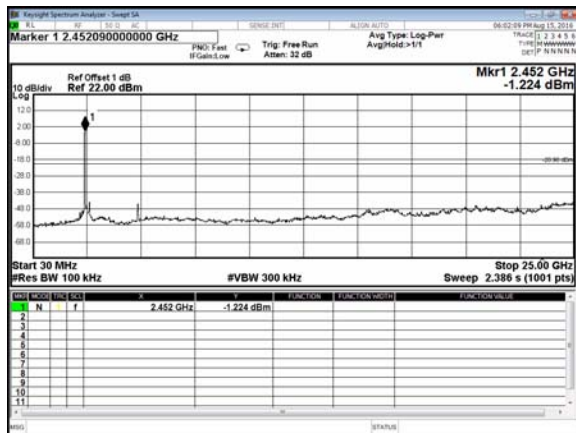
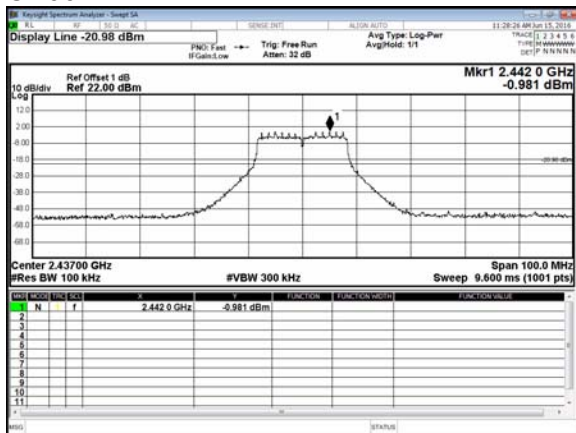

CH11

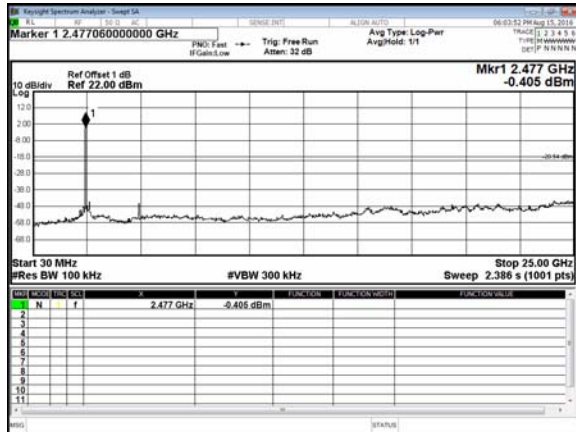
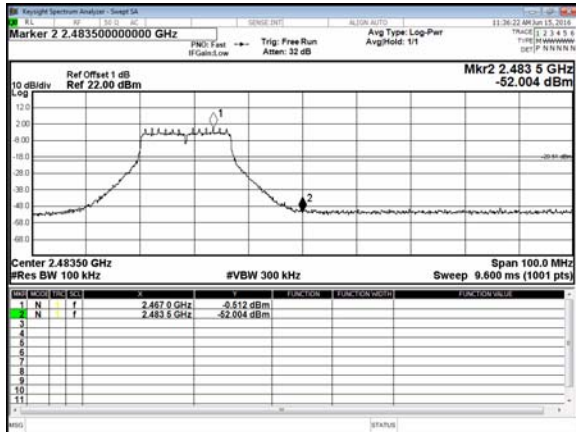





Modulation Type: 802.11n HT20  
CH01

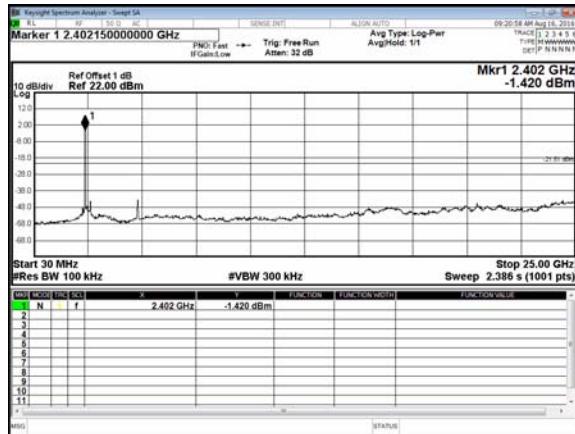
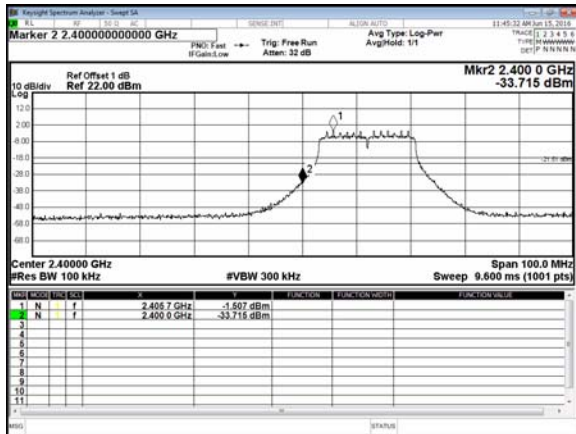

CH06

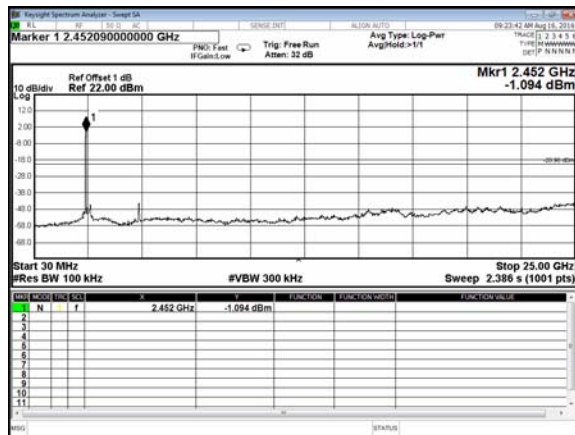
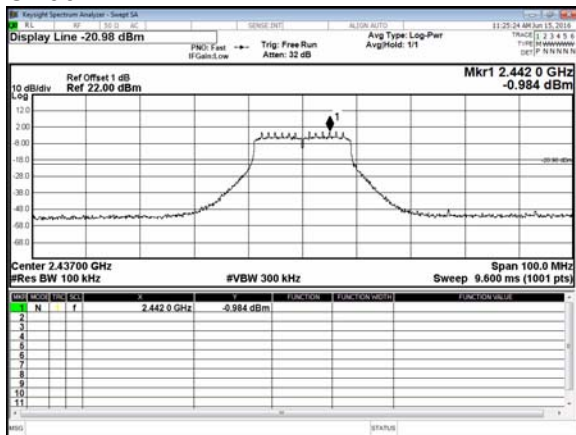

CH11

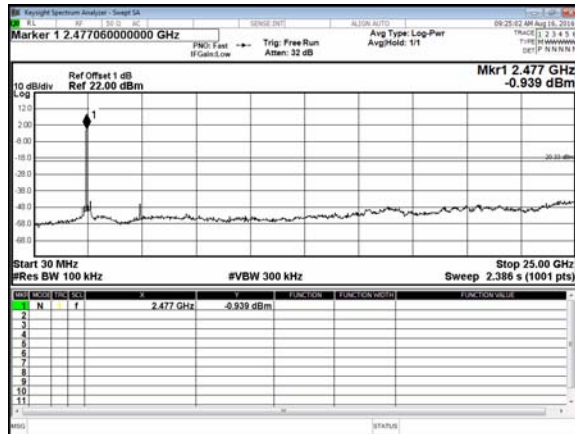
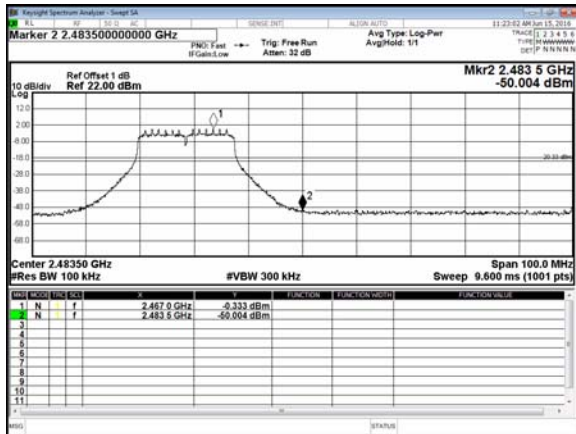



Modulation Type: 802.11n HT40  
CH03

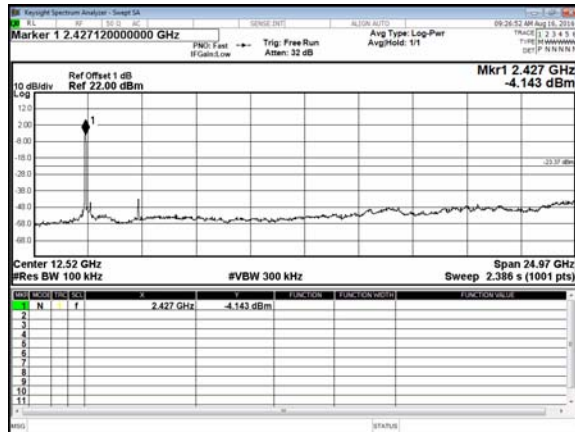
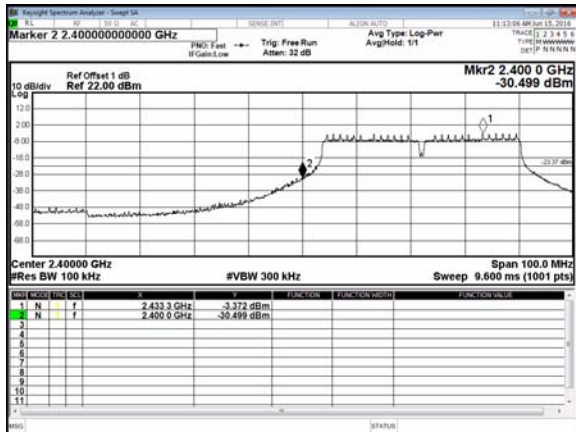

CH06

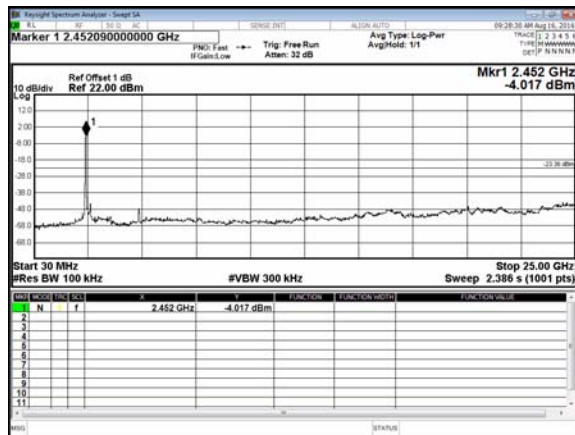
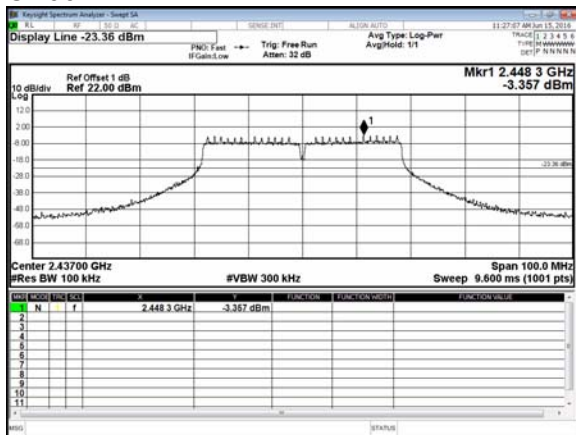

CH09

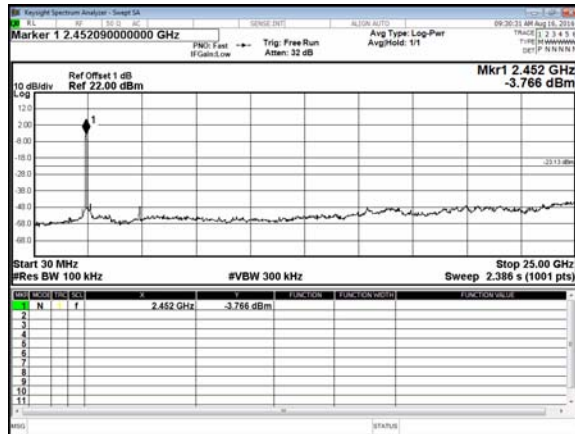
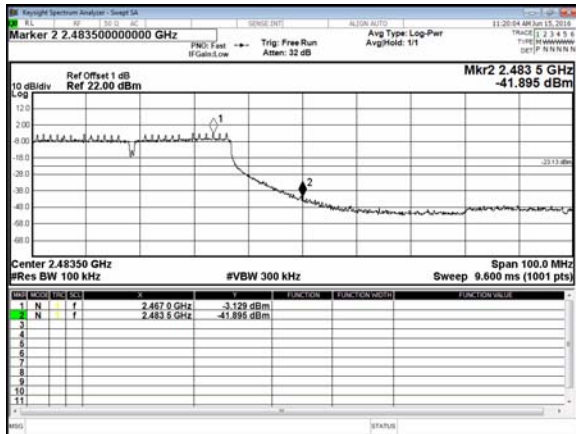



Antenna 2  
Modulation Type: 802.11b  
CH01

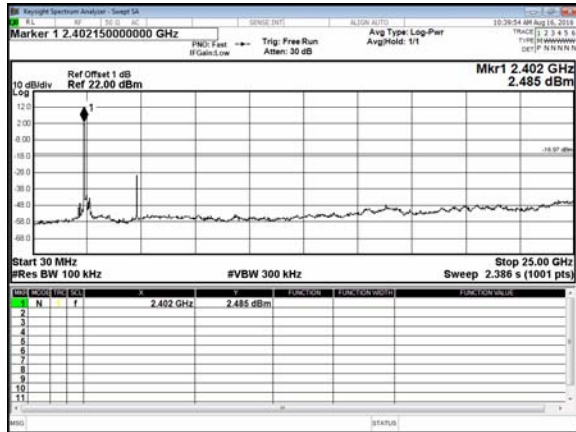
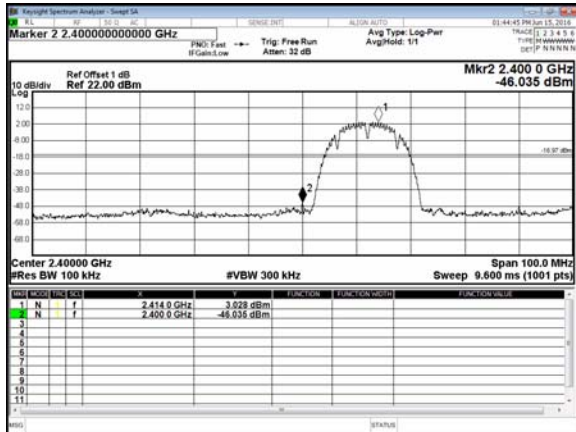

CH06

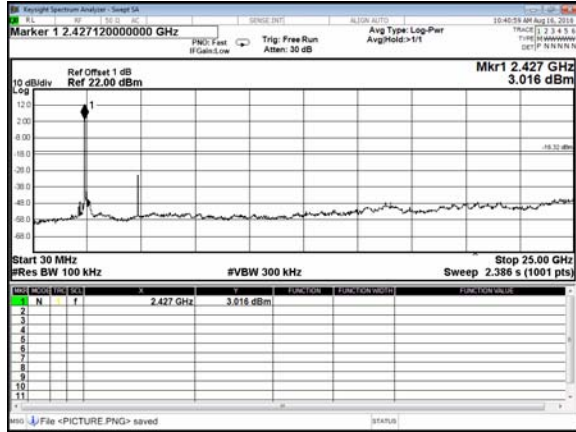
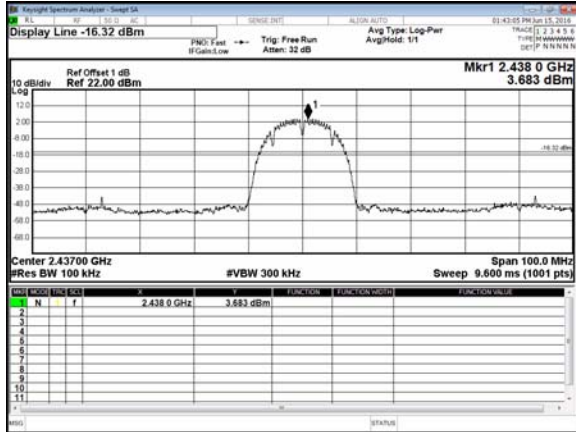

CH11

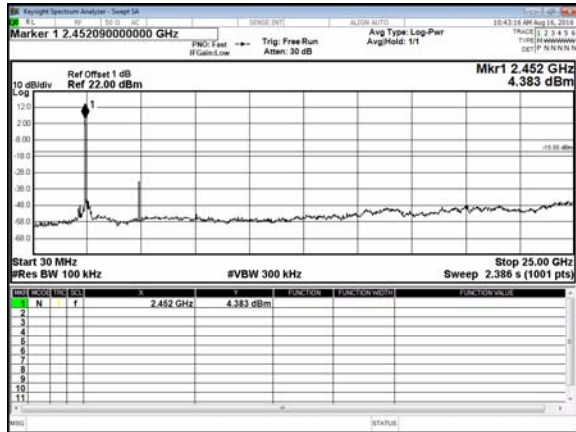
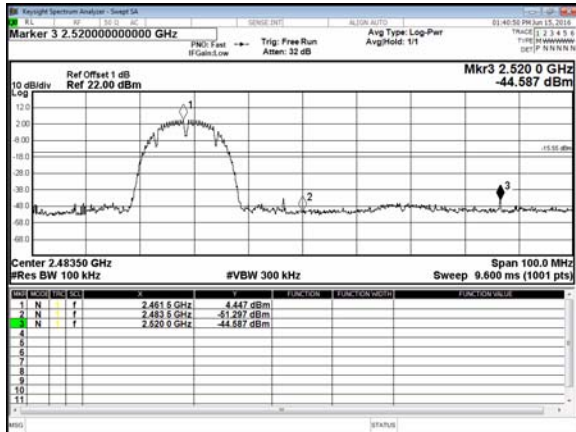



Modulation Type: 802.11g  
CH01

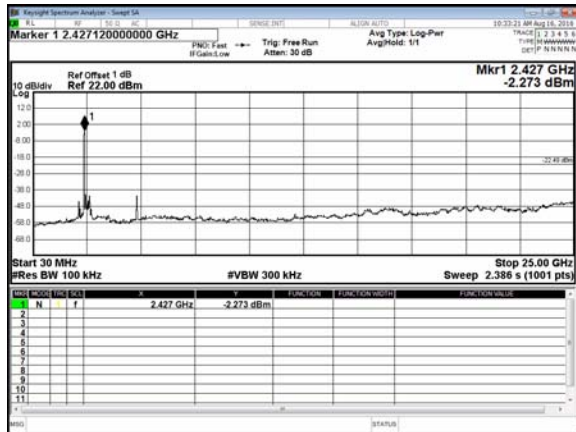
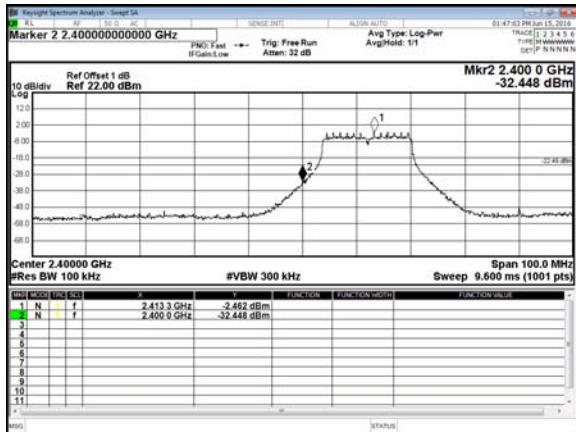

CH06

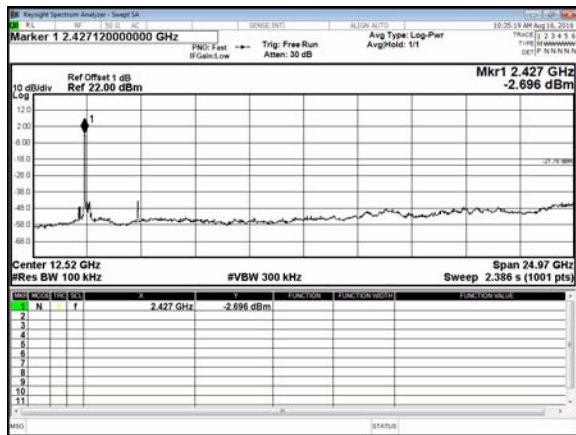
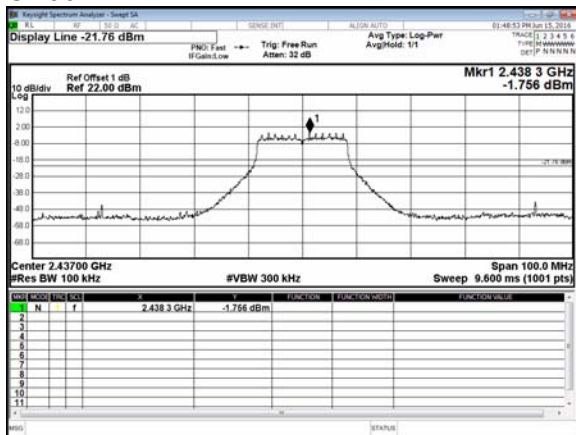

CH11

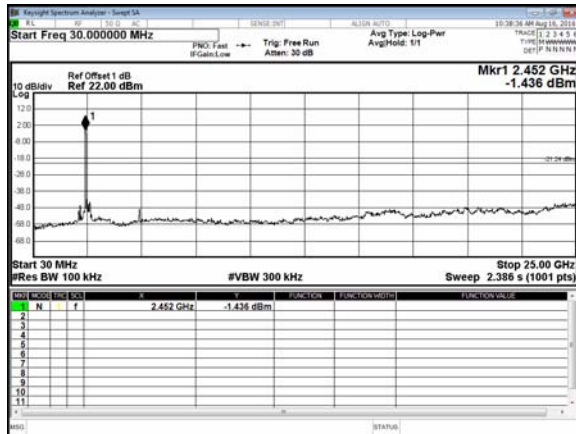
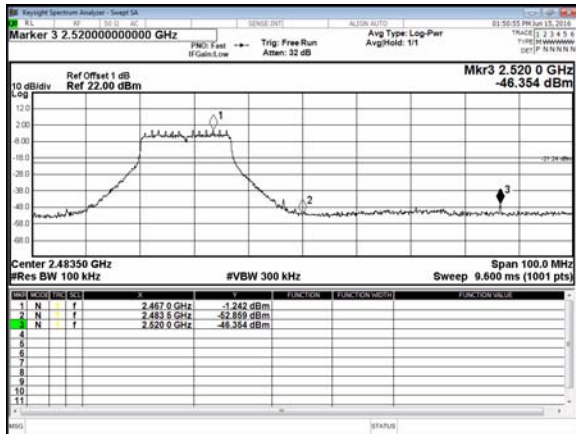



Modulation Type: 802.11n HT20  
CH01

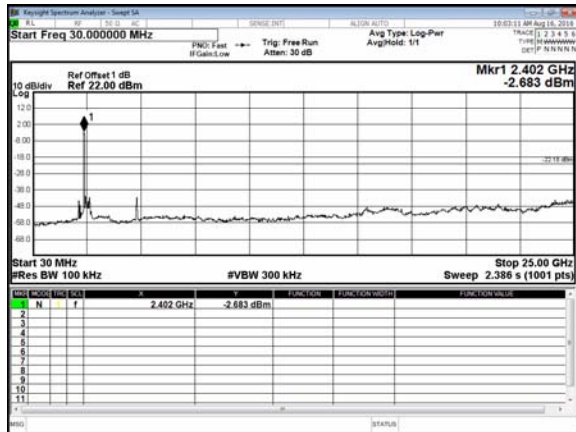
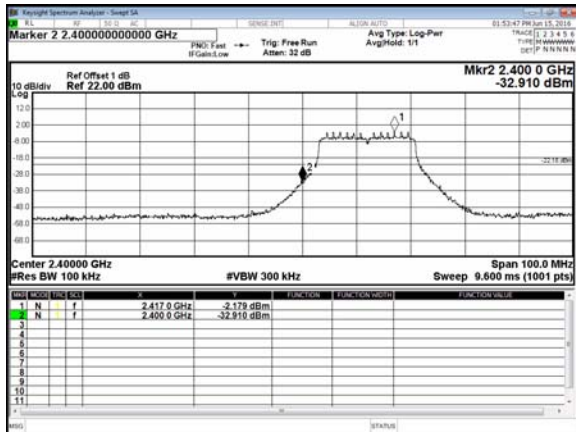

CH06

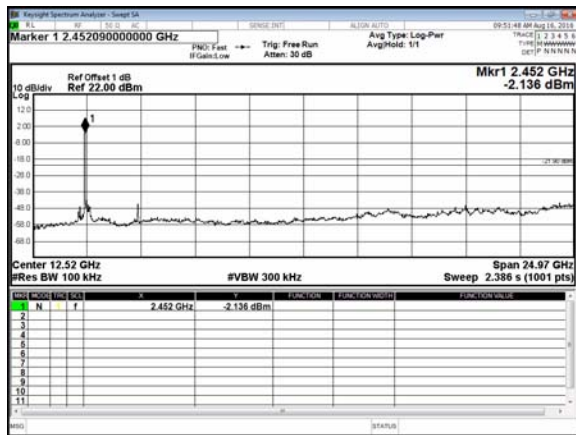
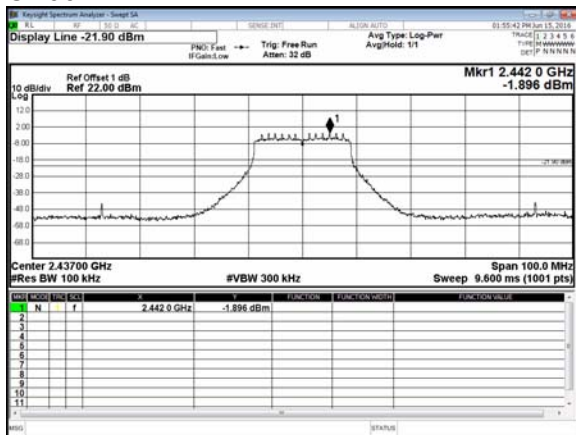

CH11

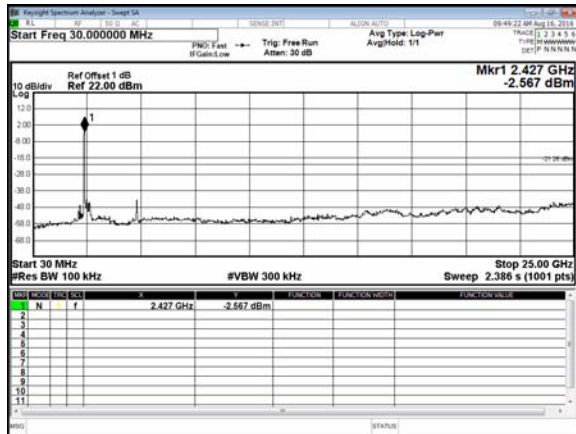
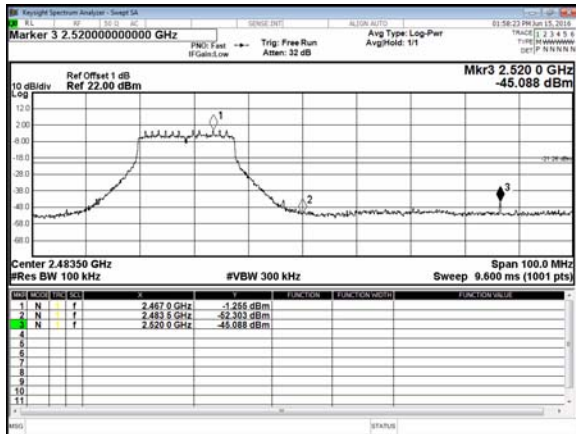



Modulation Type: 802.11n HT40  
CH03

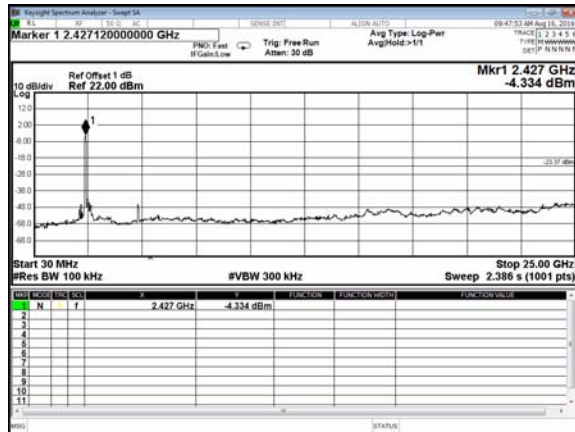
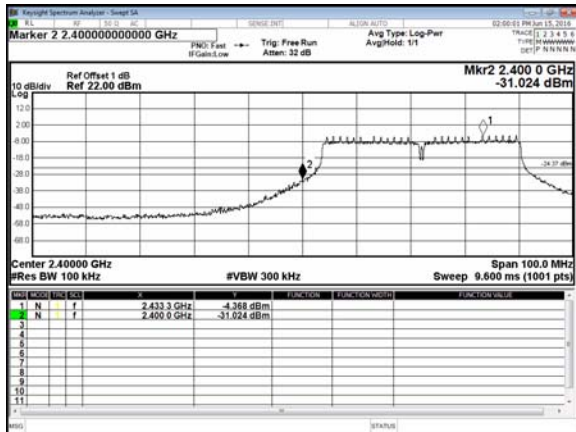

CH06

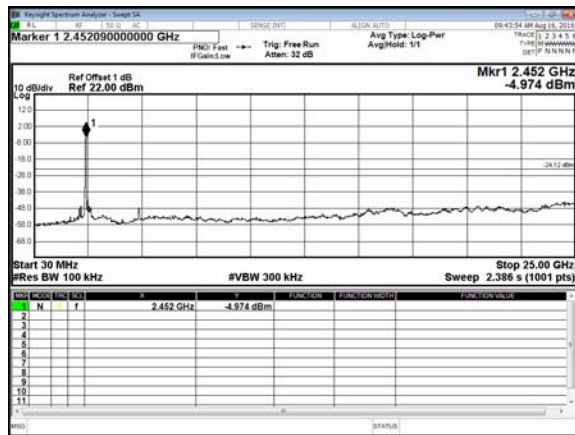
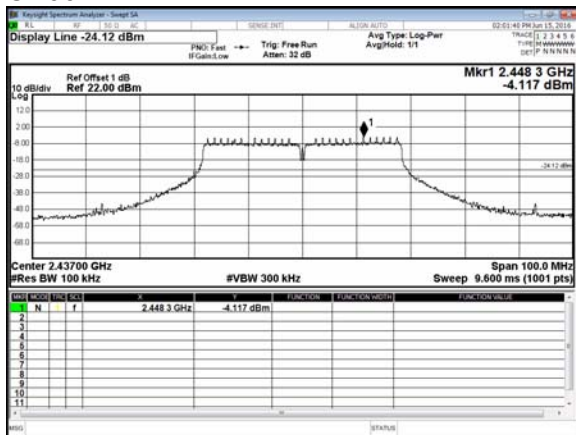

CH09

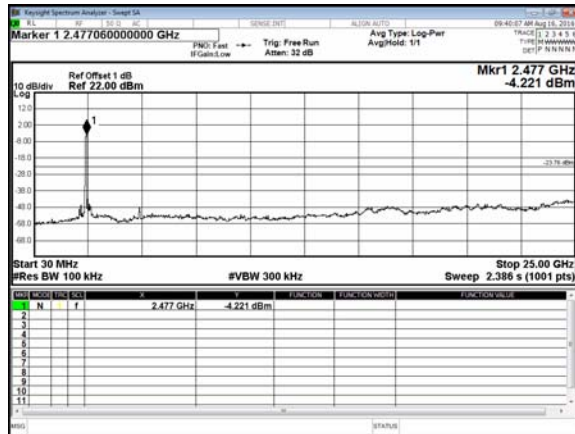
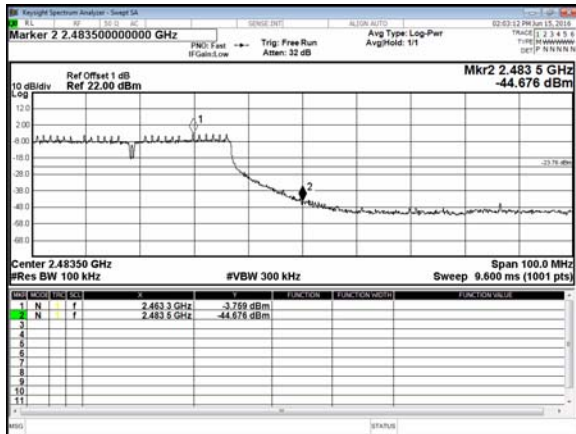



## 8. 6dB Bandwidth Measurement Data

### 8.1 Test Limit

The minimum of 6dB Bandwidth Measurement is 0.5 MHz.

### 8.2 Test Procedures

Per KDB558074 D01v03r05, section 8.2 option 2, test procedure

- a. The transmitter output was connected to the spectrum analyzer.
- b. Set RBW of spectrum analyzer to 100 KHz and VBW to 300 KHz.
- c. Set spectrum analyzer X dB to 6 dB.
- d. Set spectrum analyzer peak detector with maximum hold.

### 8.3 Test Setup Layout



### 8.4 Test Result and Data

Test Date: Jun. 12, 2016

Temperature: 24°C

Atmospheric pressure: 1016 hPa

Humidity: 46%

Ant 1

Modulation Type	Channel	Frequency (MHz)	6dB Bandwidth (MHz)
IEEE 802.11b	01	2412	10.13
	06	2437	10.13
	11	2462	10.12
IEEE 802.11g	01	2412	16.4
	06	2437	16.43
	11	2462	16.42
IEEE 802.11n HT20	01	2412	17.61
	06	2437	17.61
	11	2462	17.62
IEEE 802.11n HT40	03	2422	36.43
	06	2437	36.42
	09	2452	36.43



Ant 2

Modulation Type	Channel	Frequency (MHz)	6dB Bandwidth (MHz)
IEEE 802.11b	01	2412	10.13
	06	2437	10.12
	11	2462	10.10
IEEE 802.11g	01	2412	16.40
	06	2437	16.40
	11	2462	16.39
IEEE 802.11n HT20	01	2412	17.60
	06	2437	17.62
	11	2462	17.63
IEEE 802.11n HT40	03	2422	36.40
	06	2437	36.42
	09	2452	36.42





Antenna 1  
Modulation Type: 802.11b  
CH01

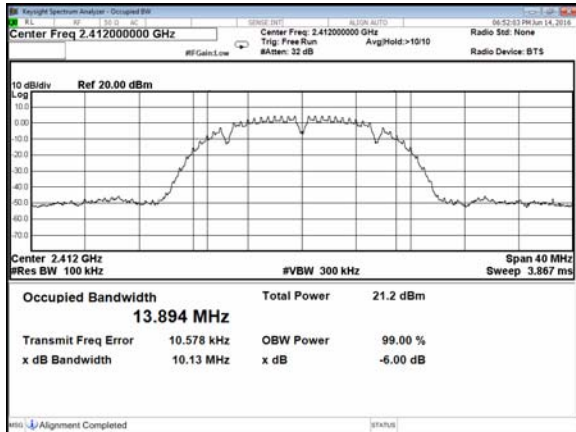

CH06

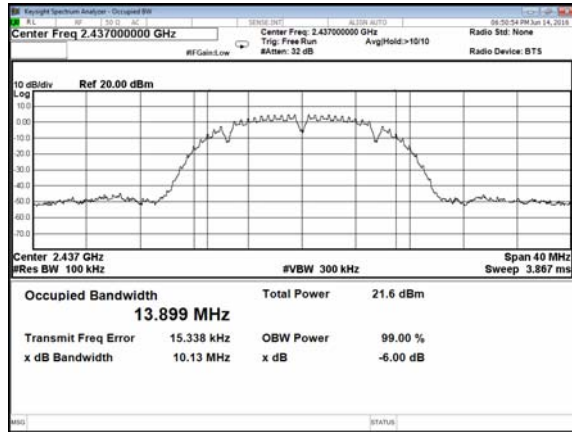

CH11

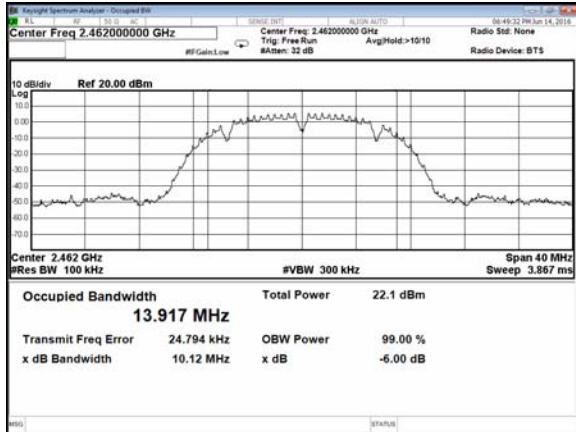

Modulation Type: 802.11g  
CH01

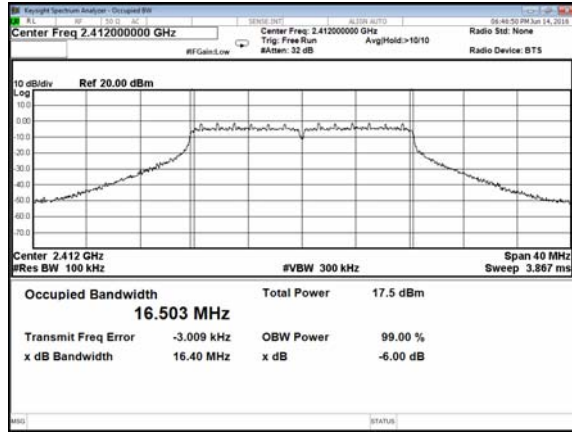

CH06

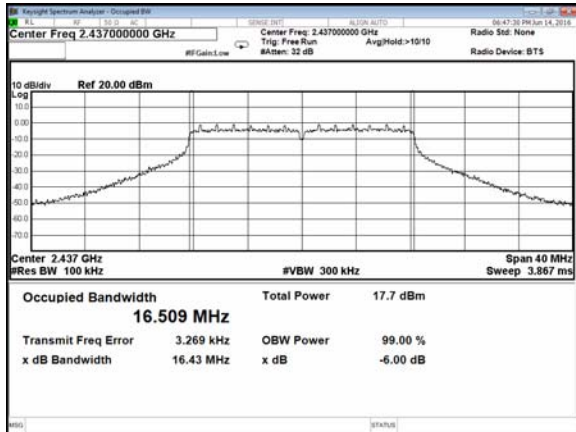

CH11





Modulation Type: 802.11n HT20  
CH01

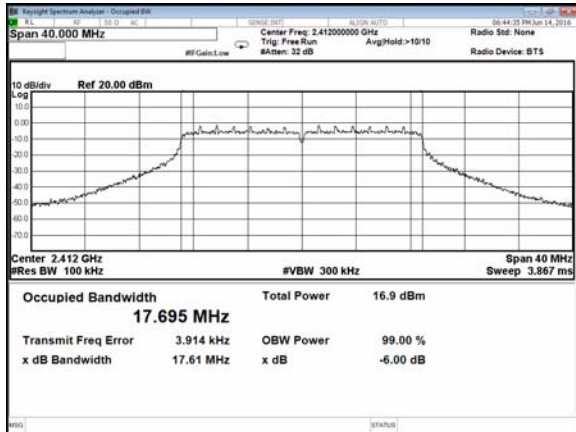

CH06



CH11

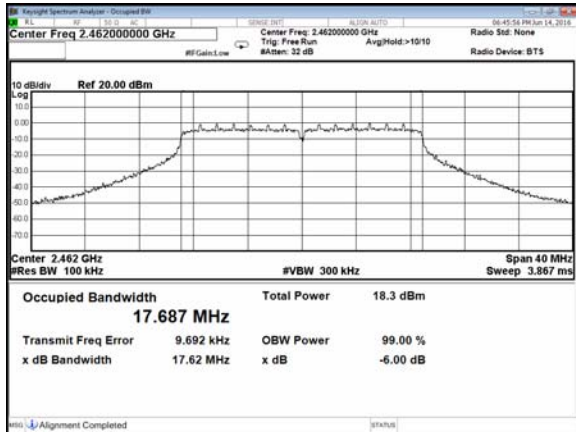

Modulation Type: 802.11n HT40  
CH03



CH06

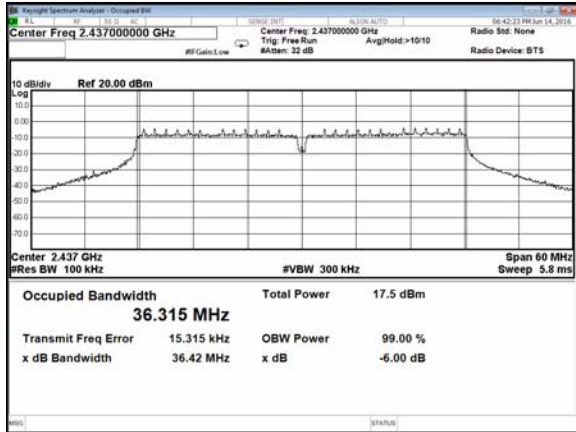

CH09





Antenna 2  
Modulation Type: 802.11b  
CH01

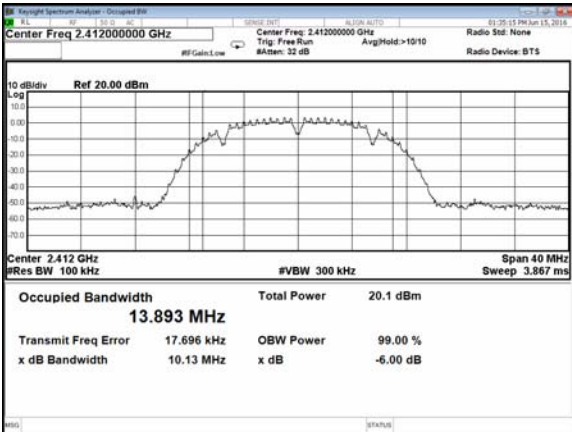

CH06

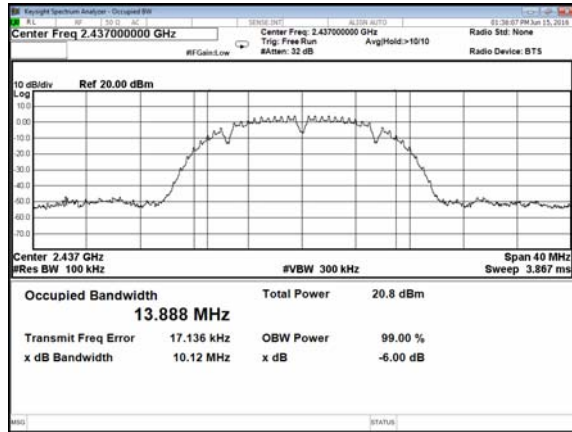

CH11

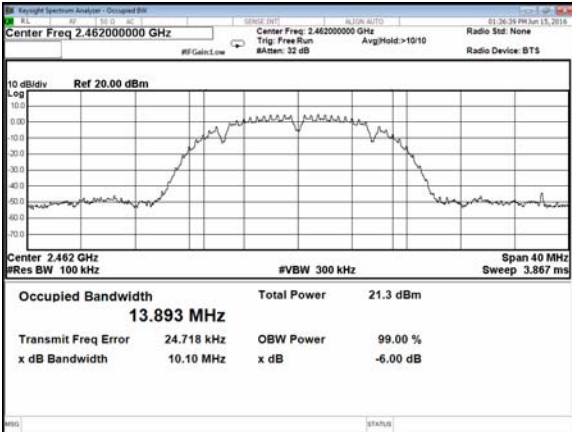

Modulation Type: 802.11g  
CH01

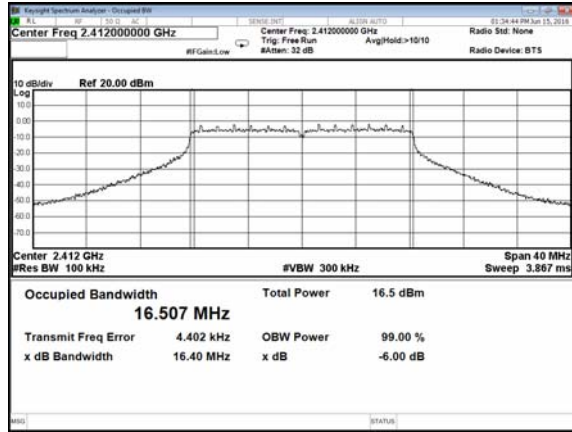

CH06

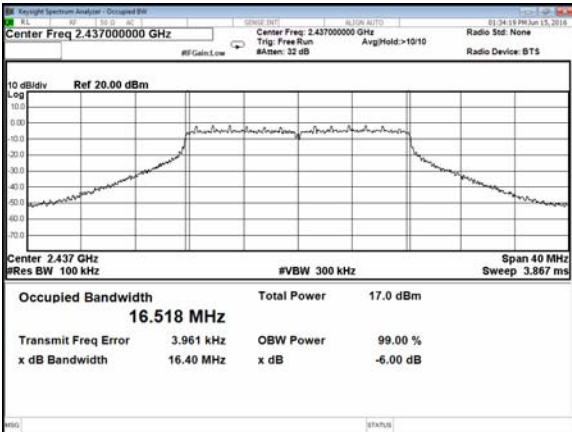

CH11

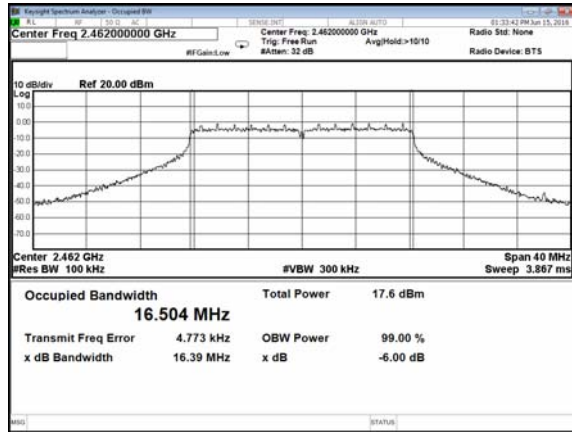



Modulation Type: 802.11n HT20  
CH01

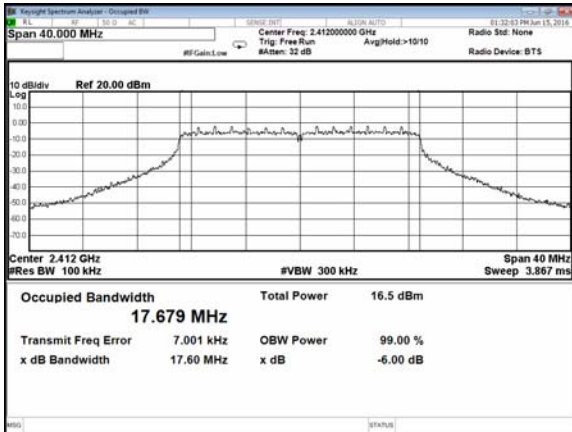

CH06

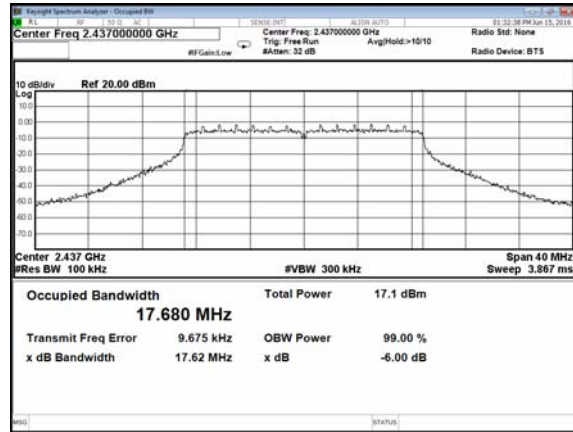

CH11

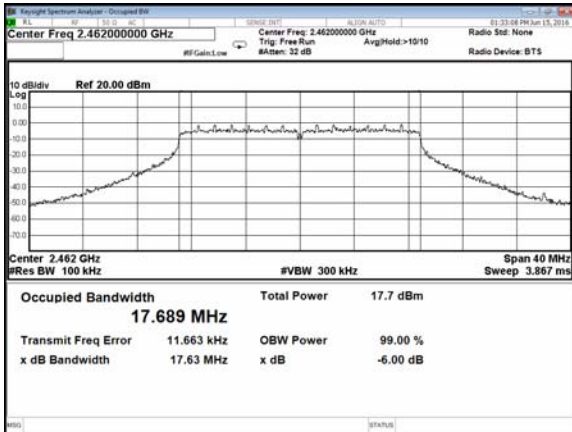

Modulation Type: 802.11n HT40  
CH03

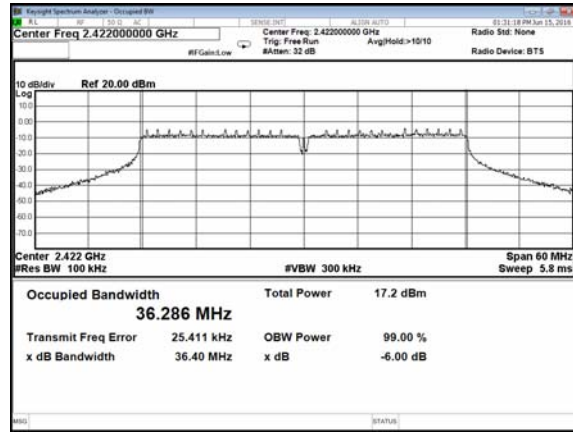

CH06

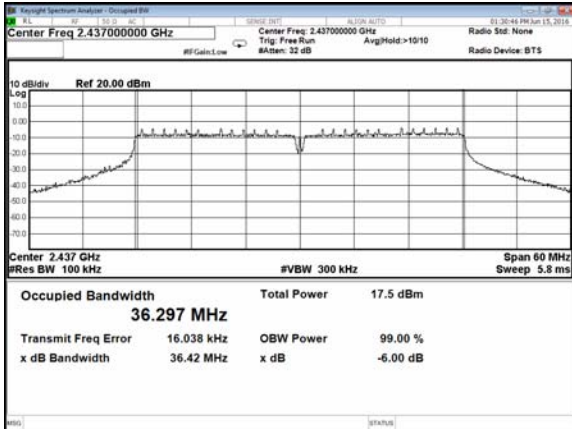

CH09

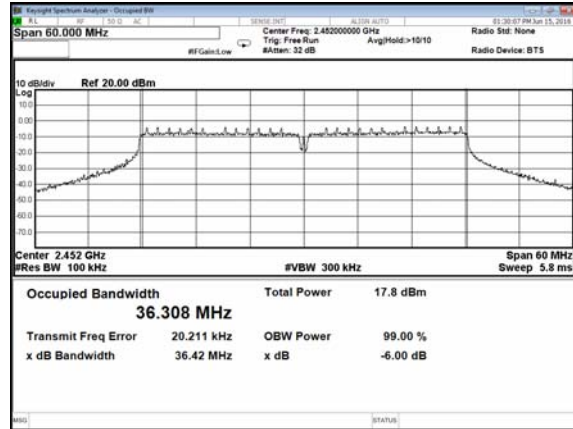



## 9. Maximum Peak Output Power

### 9.1 Test Limit

The Maximum Peak Output Power Measurement is 30dBm.

### 9.2 Test Procedures

Test procedure refers to KDB558074 D01v03r05, section 9.1.2 PKPM1 Peak power meter method.

The antenna port (RF output) of the EUT was connected to the input (RF input) of a power meter. Power was read directly from the meter and cable loss connection was added to the reading to obtain power at the EUT antenna terminal. The EUT Output Power was set to maximum to produce the worst case test result.

### 9.3 Test Setup Layout

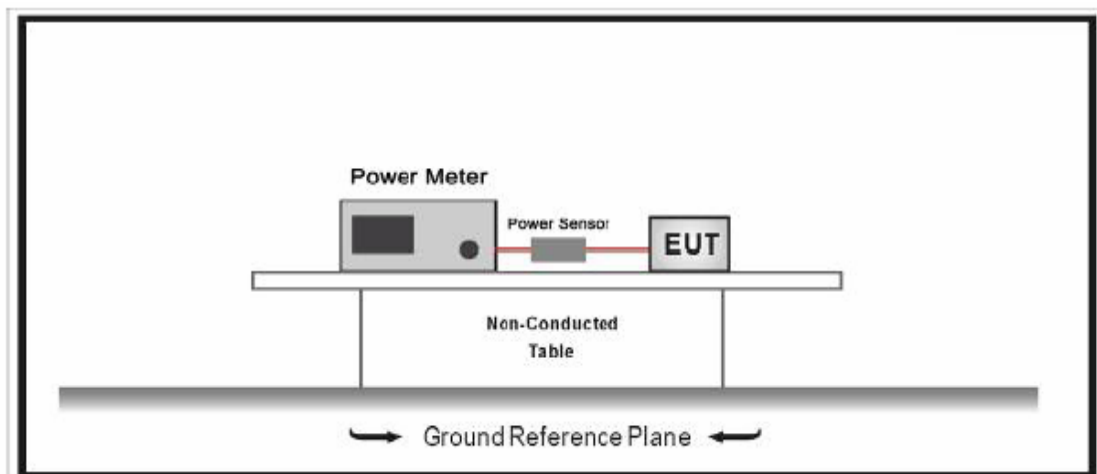



9.4 Test Result and Data

Test Date: Jun. 12, 2016

Temperature: 24°C

Atmospheric pressure: 1016 hPa

Humidity: 46%

Chain 1

Modulation Type	Channel	Frequency (MHz)	Peak Power Output (dBm)	Peak Power Output (mW)
IEEE 802.11b	01	2412	16.36	43.251
	06	2437	16.46	44.259
	11	2462	17.72	59.156
IEEE 802.11g	01	2412	18.40	69.183
	06	2437	18.53	71.285
	11	2462	18.79	75.683
IEEE 802.11n HT20	01	2412	18.23	66.527
	06	2437	18.34	68.234
	11	2462	18.97	78.832
IEEE 802.11n HT40	03	2422	18.61	72.611
	06	2437	18.48	70.469
	09	2452	19.08	80.910

Chain 2

Modulation Type	Channel	Frequency (MHz)	Peak Power Output (dBm)	Peak Power Output (mW)
IEEE 802.11b	01	2412	16.08	40.551
	06	2437	16.52	44.875
	11	2462	17.12	51.523
IEEE 802.11g	01	2412	17.45	55.590
	06	2437	17.94	62.230
	11	2462	18.40	69.183
IEEE 802.11n HT20	01	2412	17.09	51.168
	06	2437	17.57	57.148
	11	2462	18.68	73.790
IEEE 802.11n HT40	03	2422	18.02	63.387
	06	2437	18.22	66.374
	09	2452	18.51	70.958

Chain 1+2

Modulation Type	Frequency (MHz)	Peak Power (dBm) Chain 1	Peak Power (dBm) Chain 2	Peak Power (dBm) Chain 1+2	Peak Power Output (mW)
IEEE 802.11n HT20	2412	17.16	16.67	19.93	98.451
	2437	17.86	17.20	20.55	113.575
	2462	18.41	18.00	21.22	132.438
IEEE 802.11n HT40	2422	18.14	17.24	20.72	118.129
	2437	18.34	17.54	20.97	124.988
	2452	18.81	18.10	21.48	140.598



## 10. Power Spectral Density

### 10.1 Test Limit

The Maximum of Power Spectral Density Measurement is 8dBm.

### 10.2 Test Procedures

Test procedure refers to section 10.3 Method AVGPSD-1.

- a) Set instrument center frequency to DTS channel center frequency.
- b) Set span to at least 1.5 times the OBW.
- c) Set RBW to:  $3 \text{ kHz} \leq \text{RBW} \leq 100 \text{ kHz}$  .
- d) Set VBW  $\geq 3 \times \text{RBW}$ .
- e) Detector = power averaging (RMS) or sample detector (when RMS not available).
- f) Ensure that the number of measurement points in the sweep  $\geq 2 \times \text{span}/\text{RBW}$ .
- g) Sweep time = auto couple.
- h) Employ trace averaging (RMS) mode over a minimum of 100 traces.
- j) If measured value exceeds limit, reduce RBW (no less than 3 kHz) and repeat (note that this may require zooming in on the emission of interest and reducing the span in order to meet the minimum measurement point requirement as the RBW is reduced).

### 10.3 Test Setup Layout

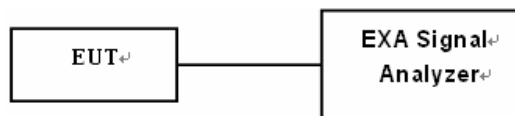



### 10.4 Test Result and Data

Test Date: Jun. 12, 2016

Temperature: 24°C

Atmospheric pressure: 1014 hPa

Humidity: 47%

Modulation Type	Frequency (MHz)	Power Spectral Density (dBm)	
		Antenna 1	Antenna 2
IEEE 802.11b	2412	-10.512	-11.758
	2437	-10.771	-11.135
	2462	-9.320	-10.720
IEEE 802.11g	2412	-14.181	-13.912
	2437	-14.752	-11.049
	2462	-14.222	-13.565
IEEE 802.11n HT20	2412	-15.351	-13.122
	2437	-15.436	-12.616
	2462	-14.611	-11.471
IEEE 802.11n HT40	2422	-17.667	-13.781
	2437	-18.189	-14.933
	2452	-18.206	-13.637

Modulation Type	Frequency (MHz)	Power Spectral Density (dBm)		
		Antenna 1	Antenna 2	Total
IEEE 802.11n HT20	2412	-17.156	-16.487	-13.80
	2437	-15.145	-14.549	-11.83
	2462	-15.487	-14.737	-12.09
IEEE 802.11n HT40	2422	-18.959	-16.488	-14.54
	2437	-19.550	-16.400	-15.62
	2452	-17.955	-16.547	-14.18





Antenna 1  
Modulation Type: 802.11b  
CH01

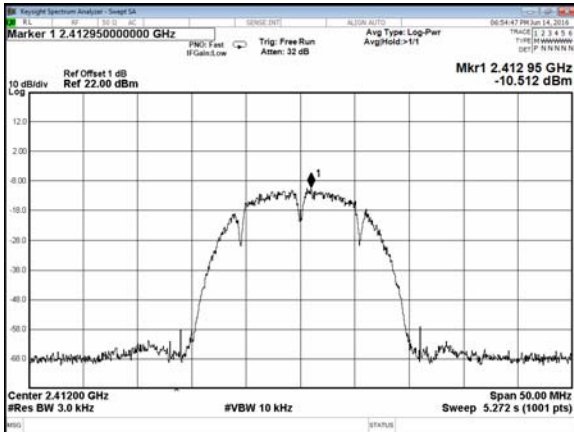

CH06

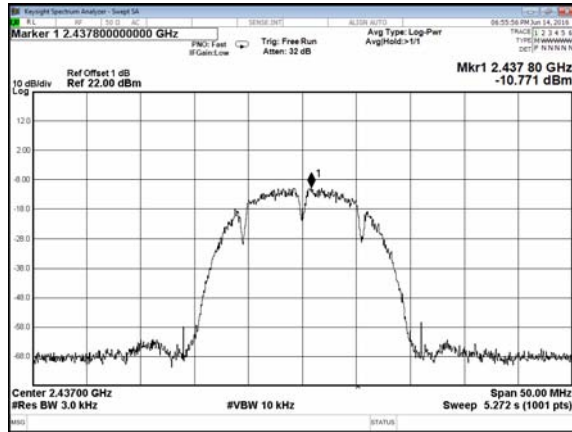

CH11

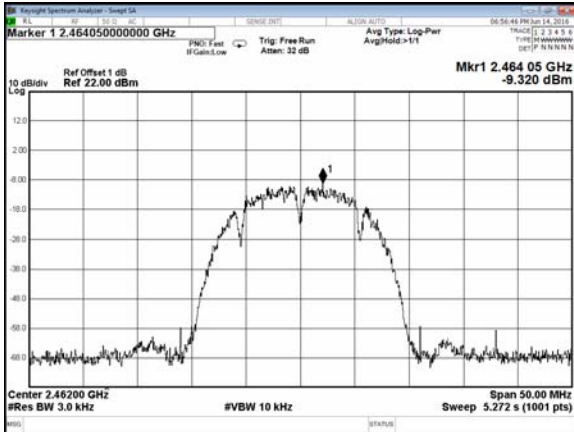

Modulation Type: 802.11g  
CH01

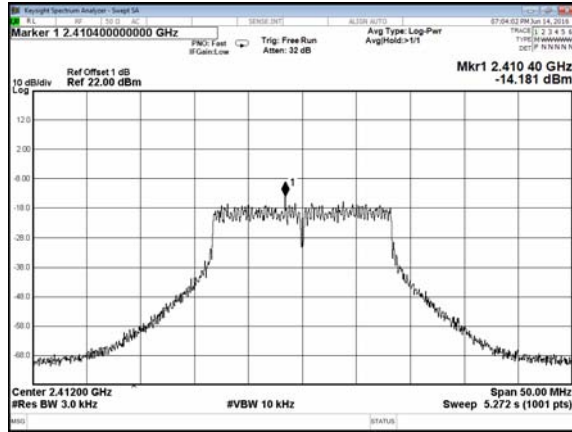

CH06

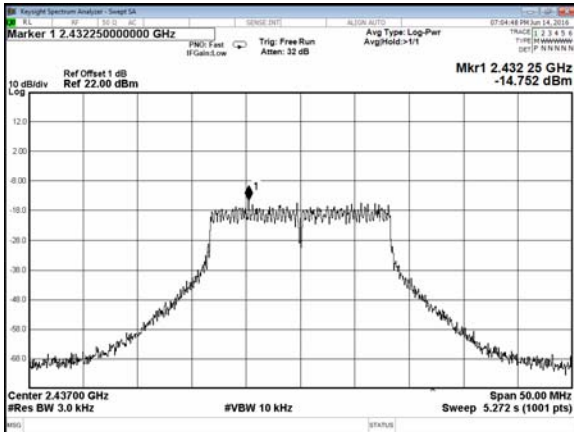

CH11

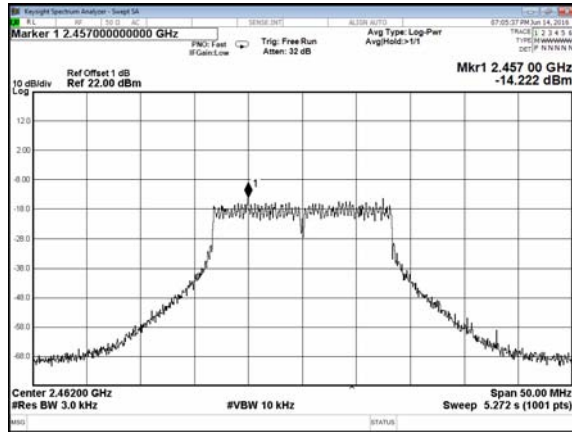



Modulation Type: 802.11n HT20  
CH01

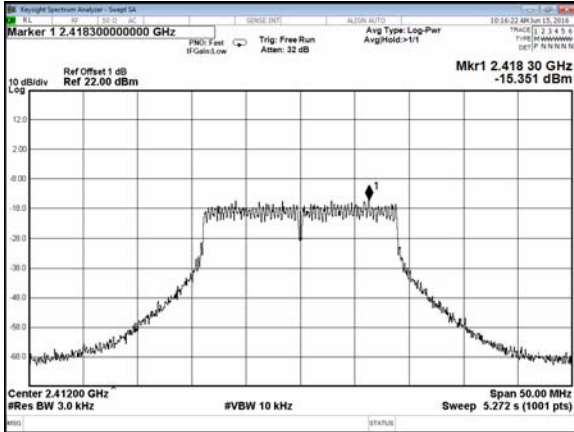

CH06

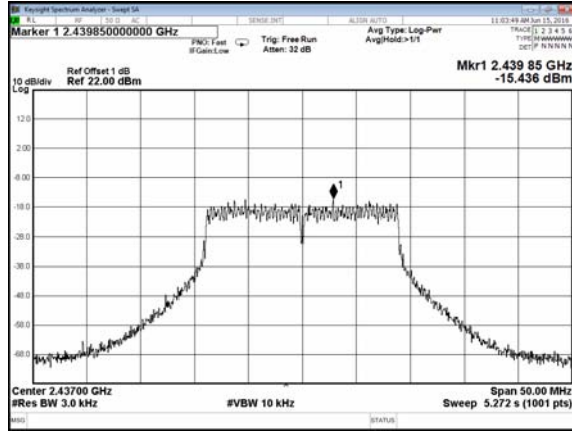

CH11

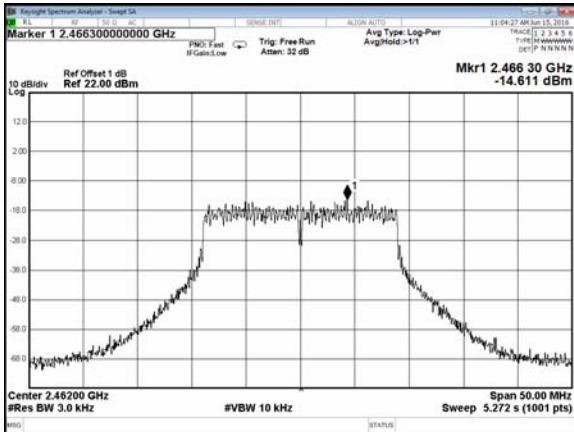

Modulation Type: 802.11n HT40  
CH03

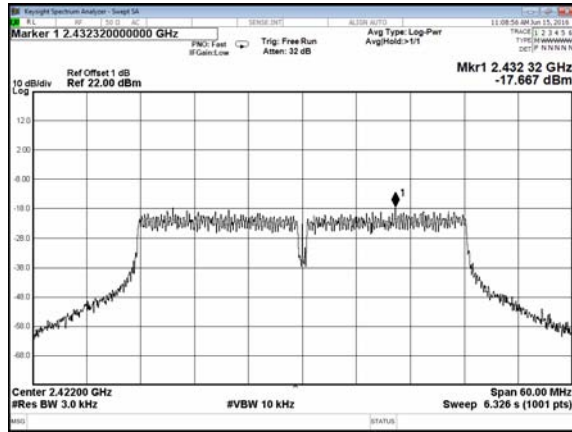

CH06

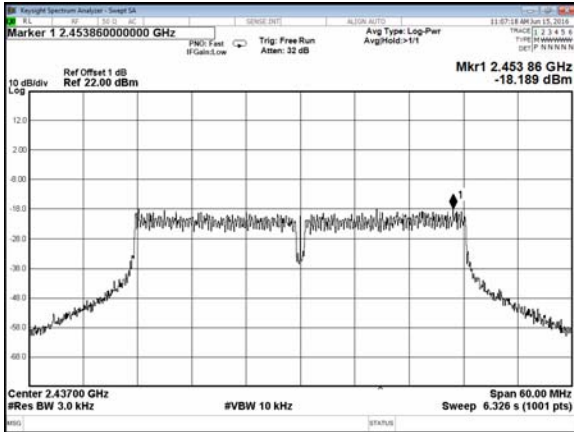

CH09

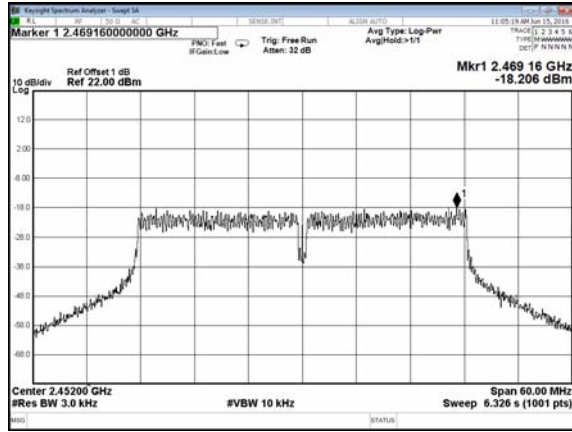



Antenna 2  
Modulation Type: 802.11b  
CH01

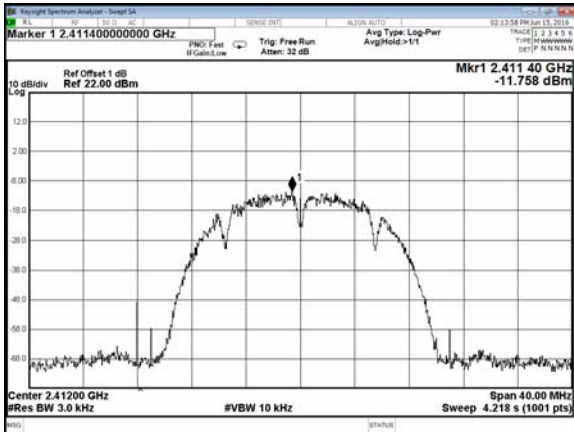

CH06

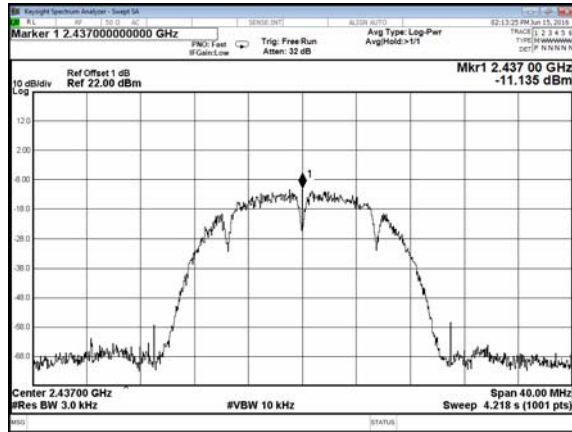

CH11

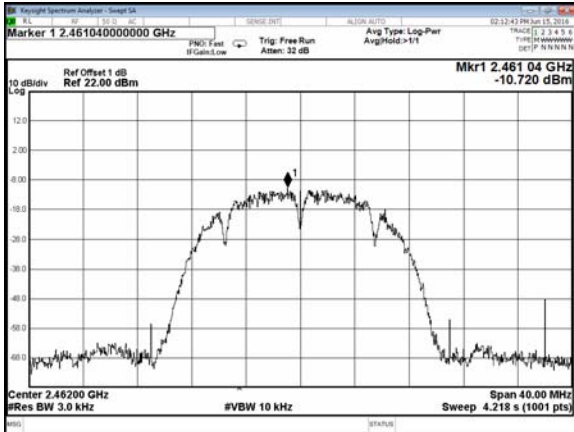

Modulation Type: 802.11g  
CH01

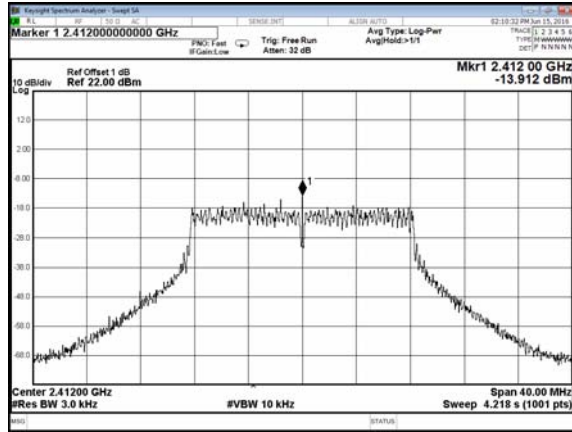

CH06

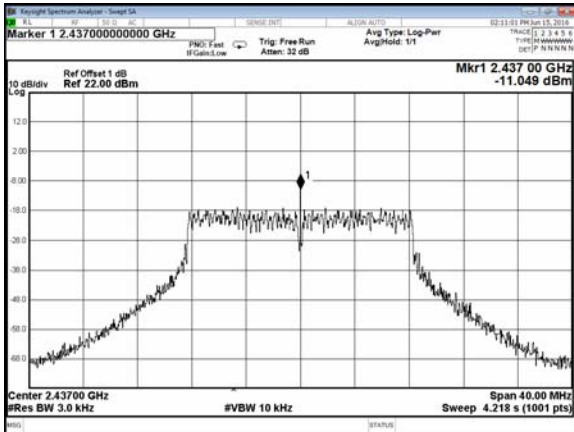

CH11

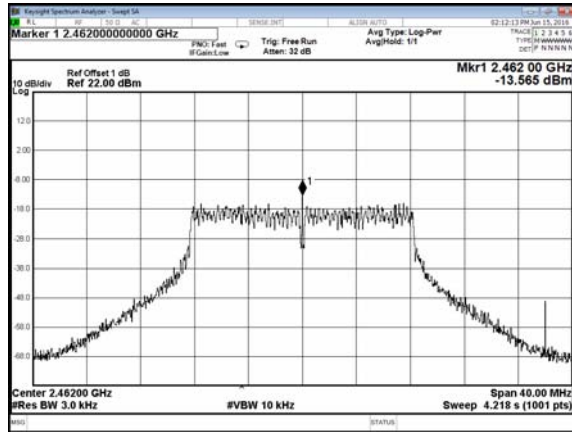



Modulation Type: 802.11n HT20  
CH01

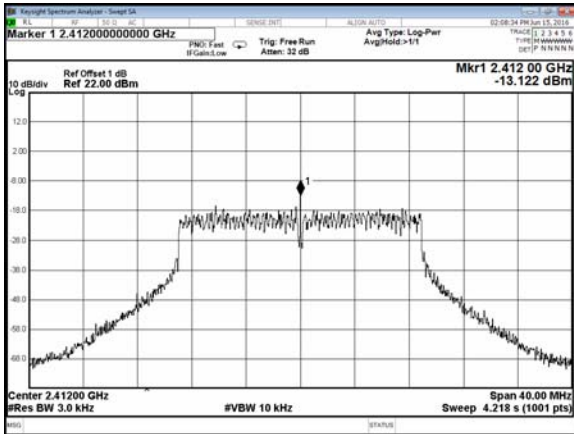

CH06

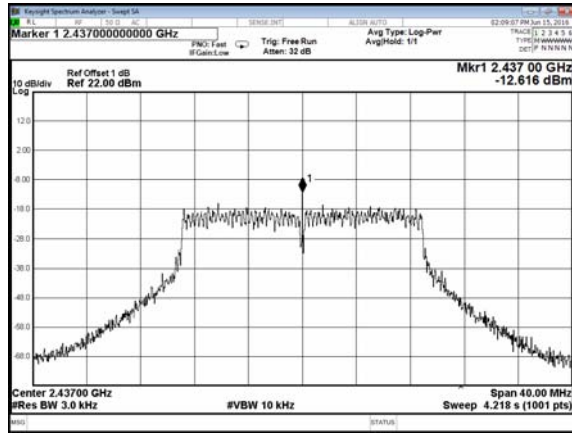

CH11

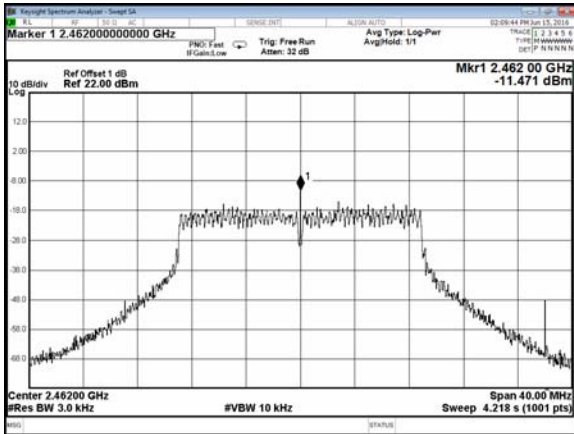

Modulation Type: 802.11n HT40  
CH03

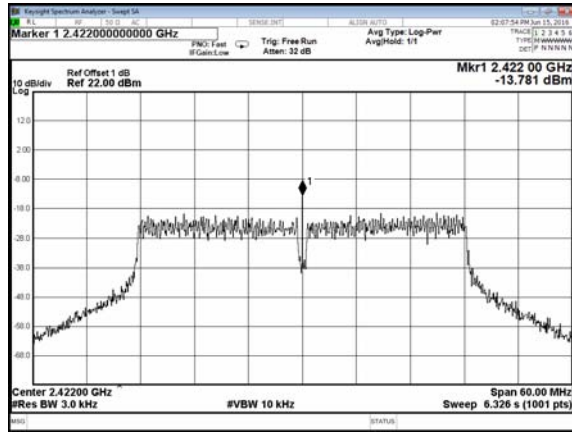

CH06

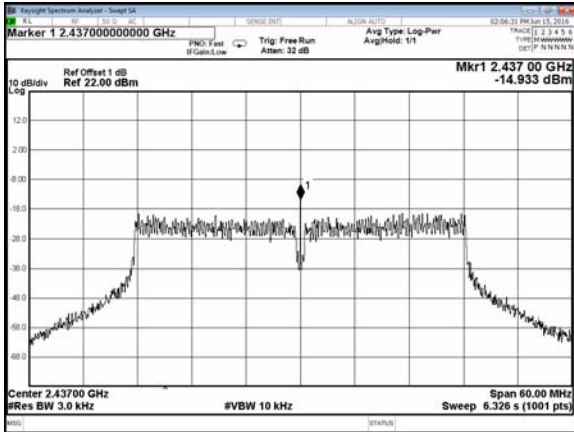

CH09

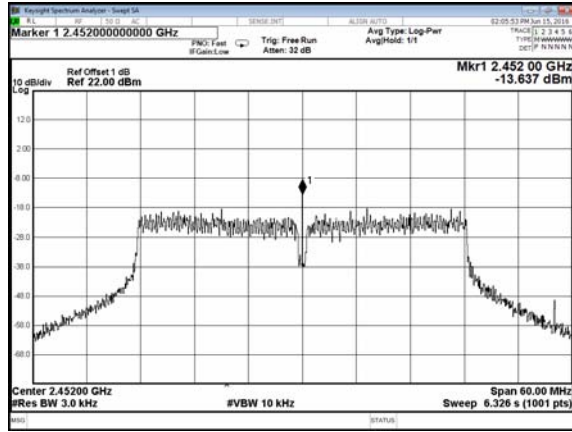



Antenna 1+2  
Antenna 1  
Modulation Type: 802.11n HT20  
CH01

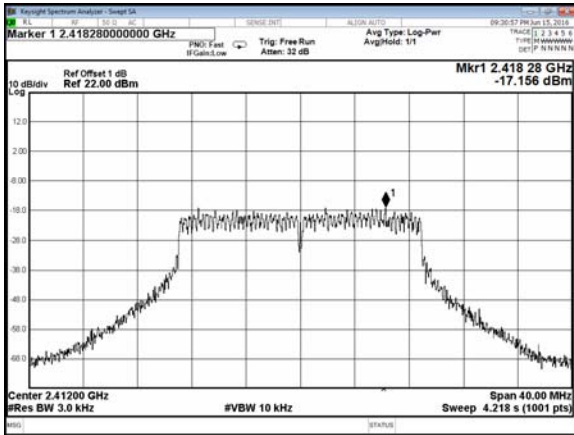

CH06

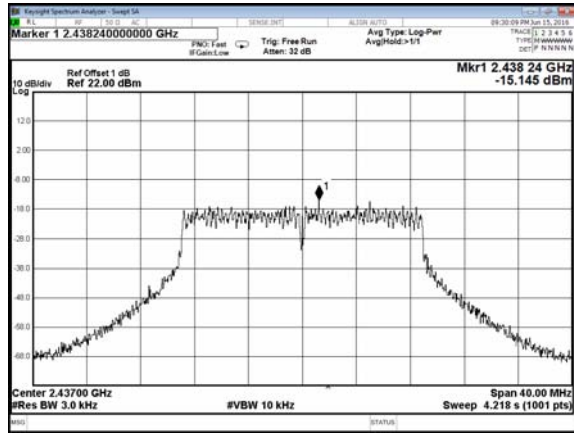

Modulation Type: 802.11n HT40  
CH03

CH11

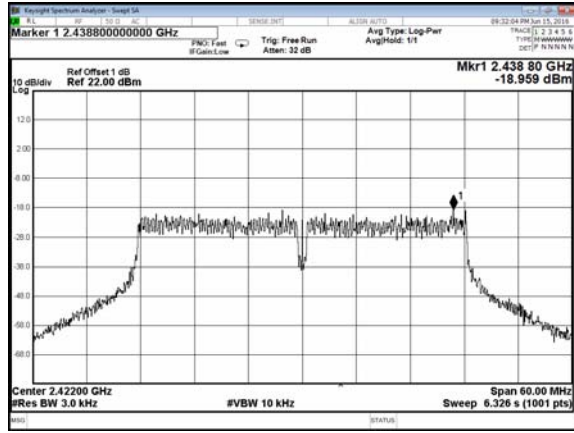
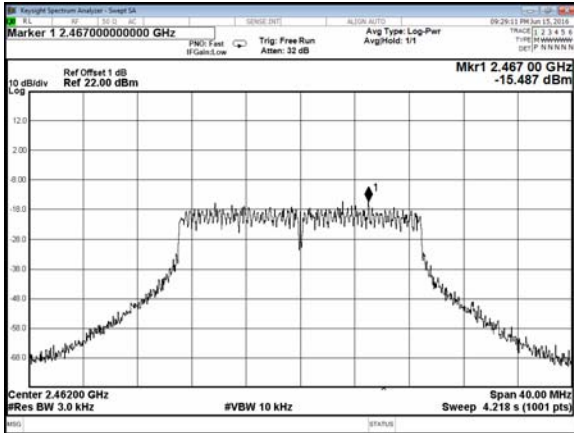

CH06

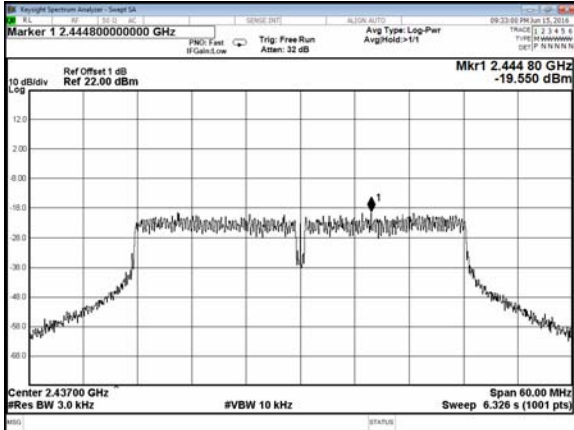

CH09

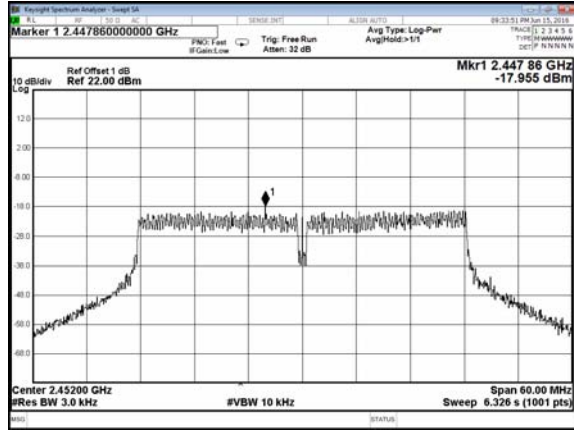



Antenna 2  
Modulation Type: 802.11n HT20  
CH01

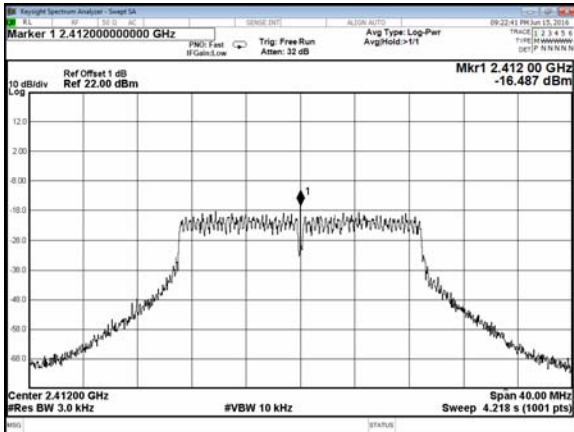

CH06

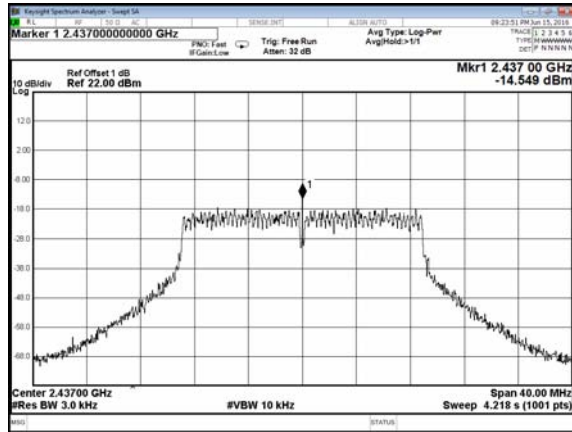

CH11

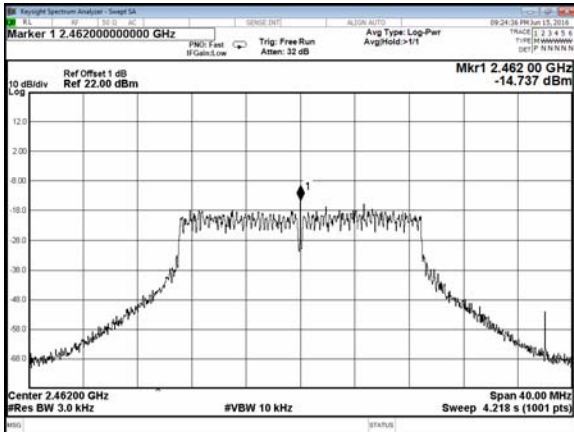

Modulation Type: 802.11n HT40  
CH03

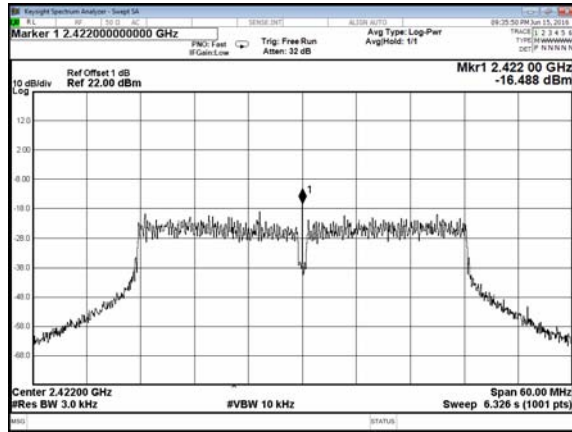

CH06

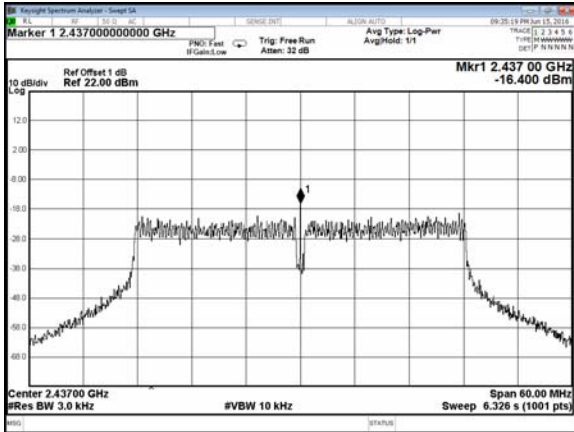

CH09

