



## FCC - TEST REPORT

Report Number : **68.950.22.0356.01** Date of Issue: May 10, 2022

Model : MWB-S-WB01-2

Product Type : Bluetooth & 2.4GHz Wi-Fi dual band Communication Module

Applicant : GD Midea Air-Conditioning Equipment Co., Ltd.

Address : Lingang Road, Beijiao, Shunde 528311 Foshan, Guangdong  
: PEOPLE'S REPUBLIC OF CHINA

Manufacturer : GD Midea Air-Conditioning Equipment Co., Ltd.

Address : Lingang Road, Beijiao, Shunde 528311 Foshan, Guangdong  
: PEOPLE'S REPUBLIC OF CHINA

Test Result :  **Positive**       **Negative**

Total pages including Appendices : 46

Any use for advertising purposes must be granted in writing. This technical report may only be quoted in full. This report is the result of a single examination of the object in question and is not generally applicable evaluation of the quality of other products in regular production. For further details, please see testing and certification regulation, chapter A-3.4.



# 1 Table of Contents

1	Table of Contents .....	2
2	Details about the Test Laboratory.....	3
3	Description of the Equipment Under Test.....	4
4	Summary of Test Standards .....	5
5	Summary of Test Results .....	6
6	General Remarks .....	7
7	Test Setups.....	8
8	Technical Requirement.....	9
8.1	Conducted Emission.....	9
8.2	Conducted peak output power.....	12
8.3	6dB bandwidth.....	14
8.4	Power spectral density.....	18
8.5	Spurious RF conducted emissions.....	22
8.6	Band edge testing.....	32
8.7	Spurious radiated emissions for transmitter .....	35
9	Test Equipment List.....	45
10	System Measurement Uncertainty.....	46



## 2 Details about the Test Laboratory

### Details about the Test Laboratory

#### Test Site 1

Company name: TÜV SÜD Certification and Testing (China) Co., Ltd. Shenzhen Branch  
Building 12&13, Zhiheng Wisdomland Business Park,  
Nantou Checkpoint Road 2, Nanshan District,  
Shenzhen City, 518052,  
P. R. China

FCC Registration No.: 514049

Telephone: 86 755 8828 6998  
Fax: 86 755 8828 5299

### 3 Description of the Equipment Under Test

Product:	Bluetooth & 2.4GHz Wi-Fi dual band Communication Module
Model no.:	MWB-S-WB01-2
Brand name:	Midea
FCC ID:	2ADQOMWBSWB012
Rating:	DC 5V, 0.5A, 2.5W
RF Transmission Frequency:	2412-2462MHz
No. of Operated Channel:	11
Modulation:	DSSS, OFDM
Antenna Type:	PCB Antenna
Antenna Gain:	0dBi
Description of the EUT:	EUT is a Bluetooth & 2.4GHz Wi-Fi dual band Communication Module with Bluetooth and WIFI function which operated at 2.4GHz.

## 4 Summary of Test Standards

Test Standards	
FCC Part 15 Subpart C 10-1-2020 Edition	PART 15 - RADIO FREQUENCY DEVICES Subpart C - Intentional Radiators

All the test methods were according to KDB 558074 D01 DTS Measurement Guidance v05r02 DTS Measurement Guidance and ANSI C63.10 (2013).



## 5 Summary of Test Results

Technical Requirements					
FCC Part 15 Subpart C					
Test Condition		Test Site	Test Result		
			Pass	Fail	N/A
§15.207	Conducted emission AC power port	Site 1	<input checked="" type="checkbox"/>	<input type="checkbox"/>	<input type="checkbox"/>
§15.247 (b) (1)	Conducted peak output power	Site 1	<input checked="" type="checkbox"/>	<input type="checkbox"/>	<input type="checkbox"/>
§15.247(a)(1)	20dB bandwidth	---	<input type="checkbox"/>	<input type="checkbox"/>	<input checked="" type="checkbox"/>
§15.247(a)(1)	Carrier frequency separation	---	<input type="checkbox"/>	<input type="checkbox"/>	<input checked="" type="checkbox"/>
§15.247(a)(1)(iii)	Number of hopping frequencies	---	<input type="checkbox"/>	<input type="checkbox"/>	<input checked="" type="checkbox"/>
§15.247(a)(1)(iii)	Dwell Time	---	<input type="checkbox"/>	<input type="checkbox"/>	<input checked="" type="checkbox"/>
§15.247(a)(2)	6dB bandwidth and 99% Occupied Bandwidth	Site 1	<input checked="" type="checkbox"/>	<input type="checkbox"/>	<input type="checkbox"/>
§15.247(e)	Power spectral density	Site 1	<input checked="" type="checkbox"/>	<input type="checkbox"/>	<input type="checkbox"/>
§15.247(d)	Spurious RF conducted emissions	Site 1	<input checked="" type="checkbox"/>	<input type="checkbox"/>	<input type="checkbox"/>
§15.247(d)	Band edge	Site 1	<input checked="" type="checkbox"/>	<input type="checkbox"/>	<input type="checkbox"/>
§15.247(d)	Spurious radiated emissions for transmitter	Site 1	<input checked="" type="checkbox"/>	<input type="checkbox"/>	<input type="checkbox"/>
§15.203	Antenna requirement	See note 2	<input checked="" type="checkbox"/>	<input type="checkbox"/>	<input type="checkbox"/>

Note 1: N/A=Not Applicable.

Note 2: The EUT uses a PCB antenna, which gain is 0dBi. In accordance to §15.203, It is considered sufficiently to comply with the provisions of this section.



## 6 General Remarks

### Remarks

This submittal(s) (test report) is intended for FCC ID: 2ADQOMWBSWB012, complies with Section 15.209, 15.247 of the FCC Part 15, Subpart C rules.

Note: The report is for 2.4GHz Wi-Fi only

### SUMMARY:

All tests according to the regulations cited on page 5 were

n - Performed

o - **Not** Performed

The Equipment Under Test

n - **Fulfills** the general approval requirements.

o - **Does not** fulfill the general approval requirements.

Sample Received Date: April 1, 2022

Testing Start Date: April 1, 2022

Testing End Date: April 24, 2022

TÜV SÜD Certification and Testing (China) Co., Ltd. Shenzhen Branch

Reviewed by:

Prepared by:

Tested by:

John Zhi  
Section Manager

Mark Chen  
Project Engineer



Carry Cai  
Test Engineer

## 7 Test Setups

### 7.1 AC Power Line Conducted Emission test setups

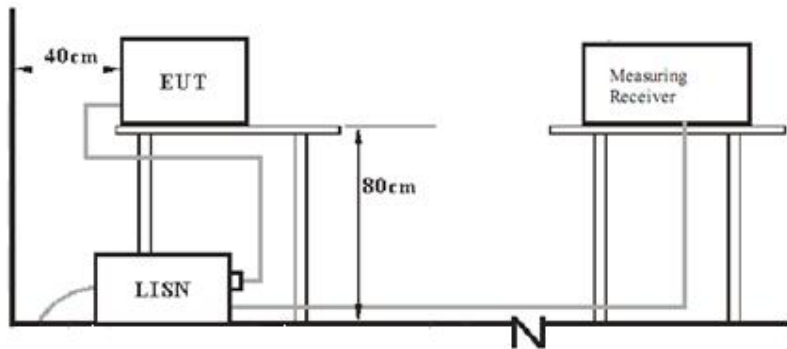

### 7.2 Radiated test setups Below 1GHz

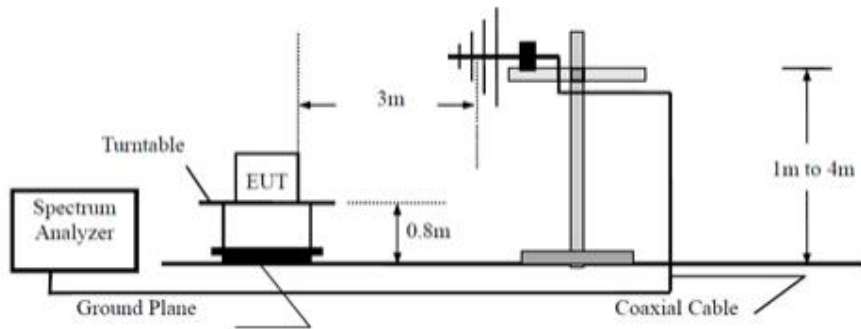

### Above 1GHz

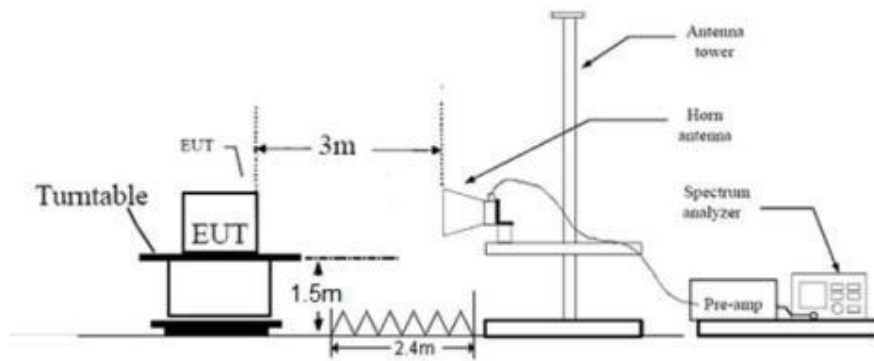

### 7.3 Conducted RF test setups

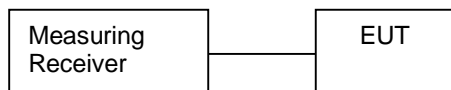





## 8 Technical Requirement

### 8.1 Conducted Emission

#### Test Method

1. The EUT was placed on a table, which is 0.8m above ground plane
2. The power line of the EUT is connected to the AC mains through a Artificial Mains Network (A.M.N.).
3. Maximum procedure was performed to ensure EUT compliance
4. A EMI test receiver is used to test the emissions from both sides of AC line

#### Limit

Frequency MHz	QP Limit dB $\mu$ V	AV Limit dB $\mu$ V
0.150-0.500	66-56*	56-46*
0.500-5	56	46
5-30	60	50

Decreasing linearly with logarithm of the frequency

Model: MWB-S-WB01-2  
 Test mode: Transmit  
 Test Voltage: AC 120V/60Hz

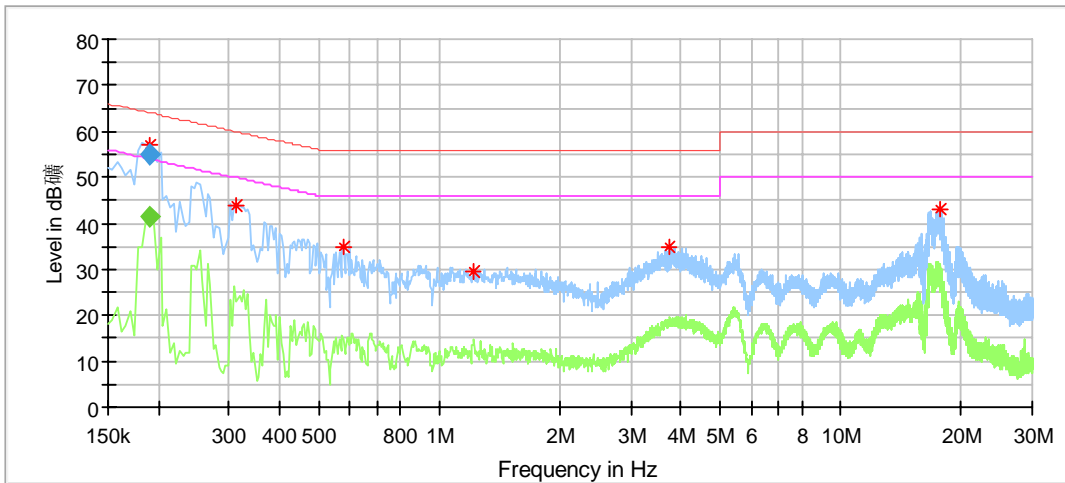

### Critical Freqs

Frequency (MHz)	MaxPeak (dBµV)	Average (dBµV)	Limit (dBµV)	Margin (dB)	Line	Corr. (dB/m)
0.189500	57.18	---	64.04	6.86	L1	9.24
0.314000	44.09	---	59.86	15.78	L1	9.22
0.578000	34.71	---	56.00	21.29	L1	9.20
1.222000	29.48	---	56.00	26.52	L1	9.20
3.750000	34.94	---	56.00	21.06	L1	9.27
17.726000	43.05	---	60.00	16.95	L1	9.42

### Final Result

Frequency (MHz)	QuasiPeak (dBµV)	Average (dBµV)	Limit (dBµV)	Margin (dB)	Line	Corr. (dB/m)
0.189500	---	41.40	54.06	12.65	L1	9.24
0.189500	55.02	---	64.06	9.04	L1	9.24

Remark:

Level=Reading Level + Correction Factor

Correction Factor=Cable Loss + LISN Factor

(The Reading Level is recorded by software which is not shown in the sheet)



Model: MWB-S-WB01-2  
 Test mode: Transmit  
 Test Voltage: AC 120V/60Hz

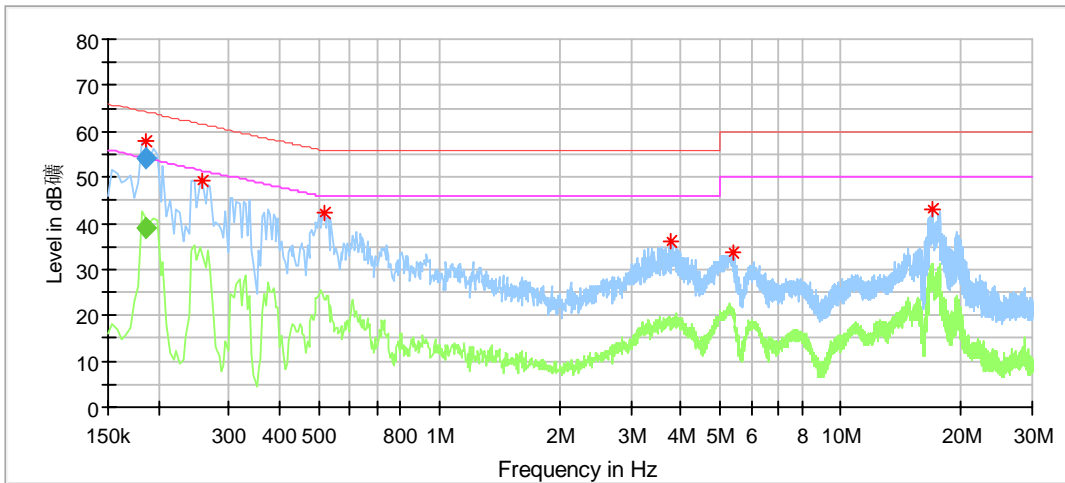

### Critical\_Freqs

Frequency (MHz)	MaxPeak (dBµV)	Average (dBµV)	Limit (dBµV)	Margin (dB)	Line	Corr. (dB/m)
0.185500	57.66	---	64.39	6.74	N	9.40
0.258000	49.14	---	61.50	12.35	N	9.39
0.518000	42.15	---	56.00	13.85	N	9.40
3.786000	36.03	---	56.00	19.97	N	9.46
5.370000	33.54	---	60.00	26.46	N	9.51
16.874000	43.13	---	60.00	16.87	N	9.67

### Final\_Result

Frequency (MHz)	QuasiPeak (dBµV)	Average (dBµV)	Limit (dBµV)	Margin (dB)	Line	Corr. (dB/m)
0.185500	---	39.16	54.24	15.08	N	9.40
0.185500	54.03	---	64.24	10.21	N	9.40

Remark:

Level=Reading Level + Correction Factor

Correction Factor=Cable Loss + LISN Factor

(The Reading Level is recorded by software which is not shown in the sheet)

## 8.2 Conducted peak output power

### Test Method

- 1) The EUT is configured to transmit continuously, or to transmit with a constant duty cycle.
- 2) At all times when the EUT is transmitting, it shall be transmitting at its maximum power control level.
- 3) The integration period of the power meter exceeds the repetition period of the transmitted signal by at least a factor of five.
- 4) Measure the peak power of the transmitter. This measurement is a peak over both the ON and OFF periods of the transmitter.

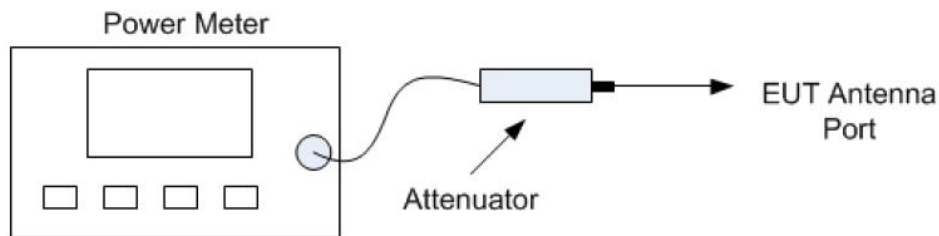

**Power meter conducted test setup**

### Limits

According to §15.247 (b) (1), conducted peak output power limit as below:

Frequency Range MHz	Limit W	Limit dBm
2400-2483.5	≤1	≤30

Test result as below table

802.11b modulation Test Result

Frequency (MHz)	Conducted Peak Output Power (dBm)	Limit (dBm)	Result
Low channel 2412MHz	17.64	30	Pass
Middle channel 2437MHz	17.68	30	Pass
High channel 2462MHz	17.71	30	Pass

802.11g modulation Test Result

Frequency (MHz)	Conducted Peak Output Power (dBm)	Limit (dBm)	Result
Low channel 2412MHz	21.08	30	Pass
Middle channel 2437MHz	21.28	30	Pass
High channel 2462MHz	21.34	30	Pass

802.11n20 modulation Test Result

Frequency (MHz)	Conducted Peak Output Power (dBm)	Limit (dBm)	Result
Low channel 2412MHz	21.83	30	Pass
Middle channel 2437MHz	21.89	30	Pass
High channel 2462MHz	21.95	30	Pass



### 8.3 6dB bandwidth

#### Test Method for 6 dB Bandwidth

1. Use the following spectrum analyzer settings:  
RBW=100K, VBW≥3RBW, Sweep = auto, Detector function = peak, Trace = max hold
2. Use the automatic bandwidth measurement capability of an instrument, may be employed using the X dB bandwidth mode with X set to 6 dB, care shall be taken so that the bandwidth measurement is not influenced by any intermediate power nulls in the fundamental emission that might be ≥ 6 dB.
3. Allow the trace to stabilize, record the X dB Bandwidth value.

#### Limit

Limit [kHz]

≥500

TestMode	Antenna	Channel(MHz)	DTS BW [MHz]	FL[MHz]	FH[MHz]	Limit[MHz]	Verdict
11B	Ant1	2412	10.120	2406.920	2417.040	0.5	PASS
		2437	10.160	2431.920	2442.080	0.5	PASS
		2462	10.160	2456.920	2467.080	0.5	PASS
11G	Ant1	2412	16.400	2403.800	2420.200	0.5	PASS
		2437	16.400	2428.800	2445.200	0.5	PASS
		2462	16.400	2453.800	2470.200	0.5	PASS
11N20SISO	Ant1	2412	17.680	2403.160	2420.840	0.5	PASS
		2437	17.880	2428.040	2445.920	0.5	PASS
		2462	17.680	2453.160	2470.840	0.5	PASS

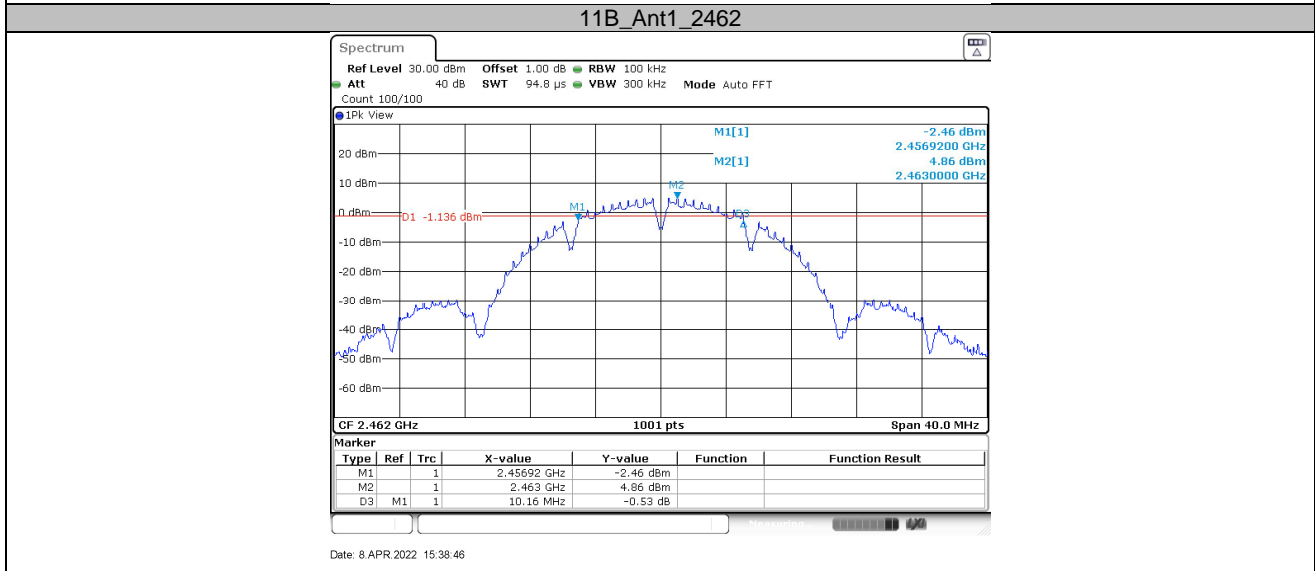
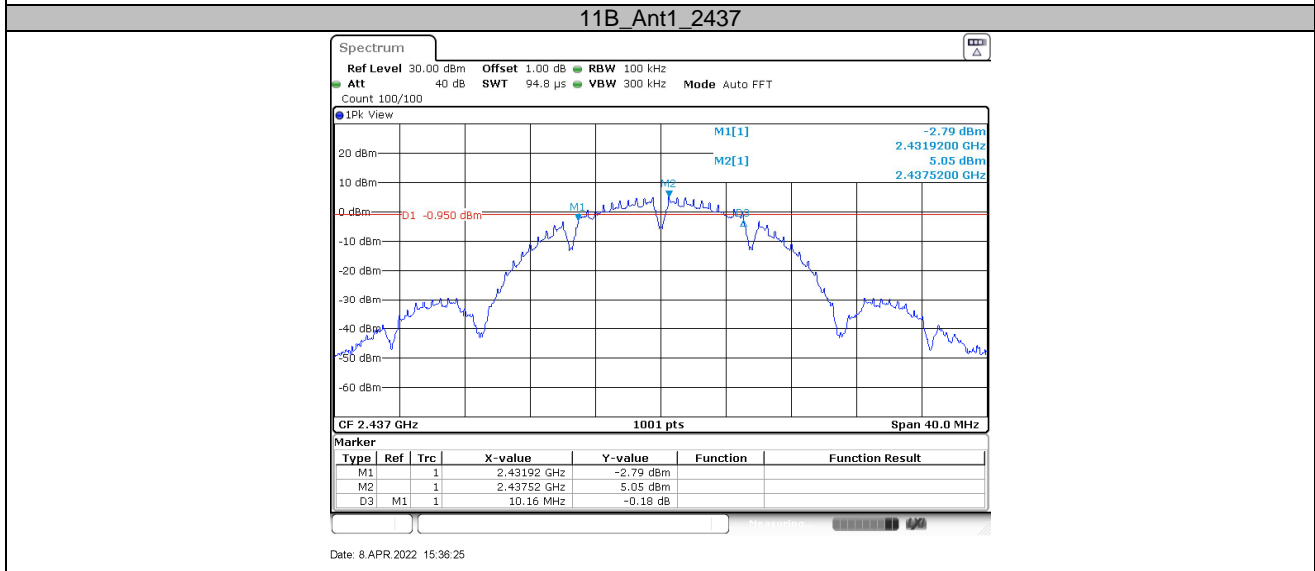
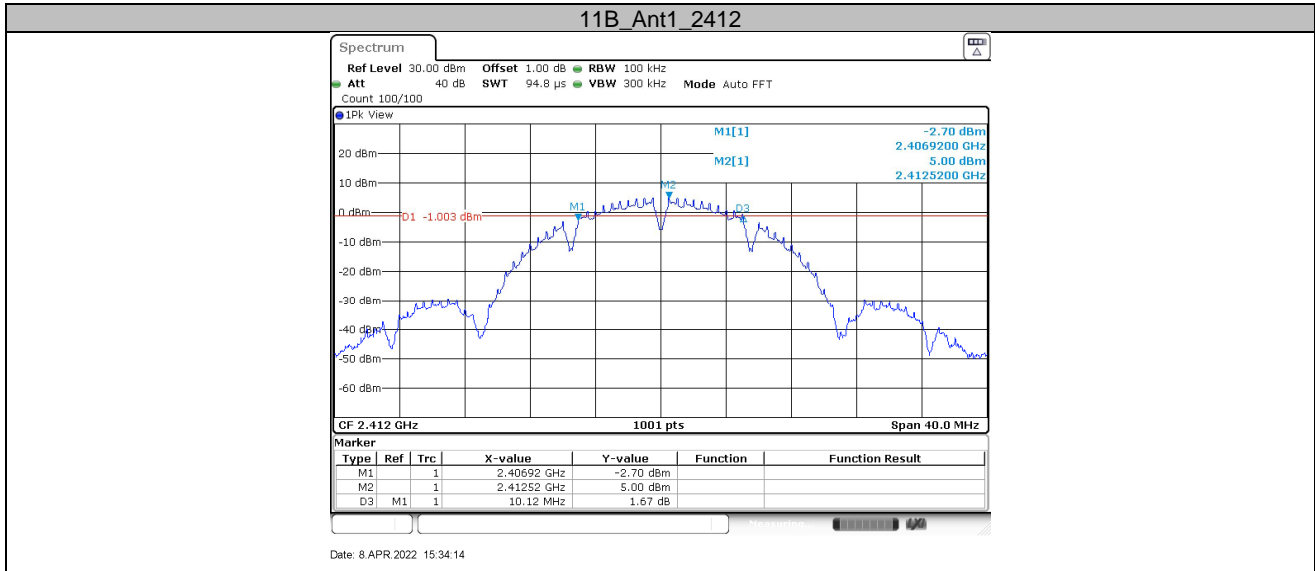



11G\_Ant1\_2412

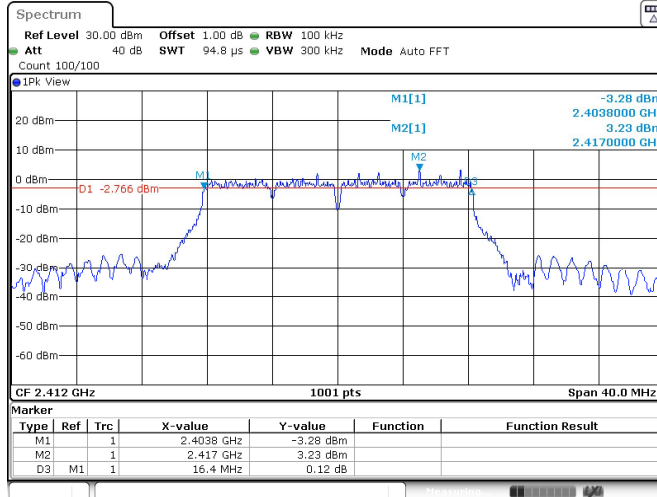

Date: 8 APR 2022 15:44:55

11G\_Ant1\_2437

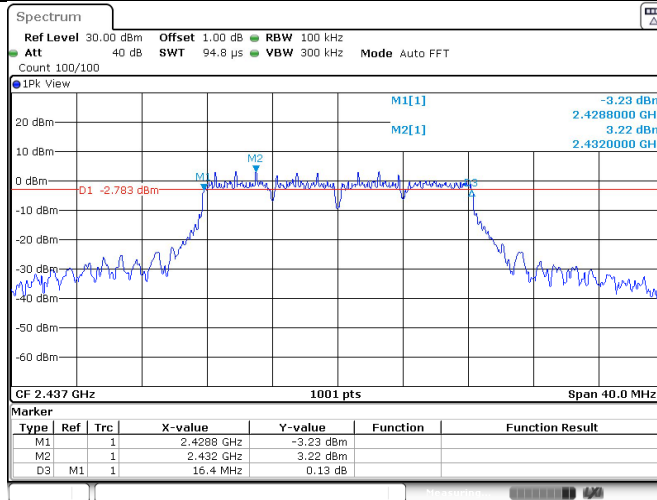

Date: 8 APR 2022 15:48:52

11G\_Ant1\_2462

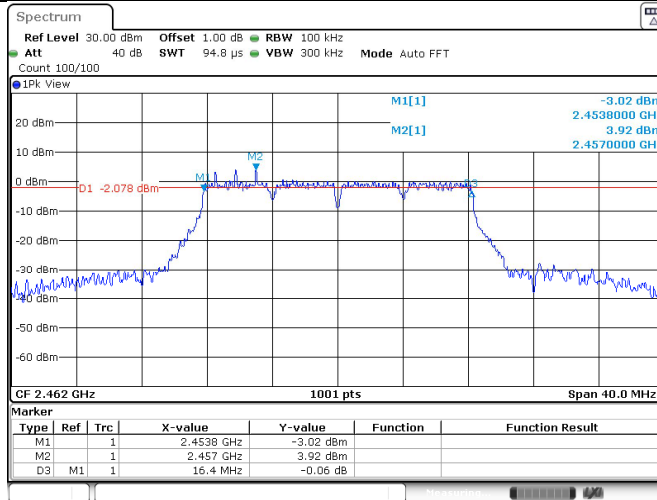

Date: 8 APR 2022 15:52:10





11N20SISO\_Ant1\_2412

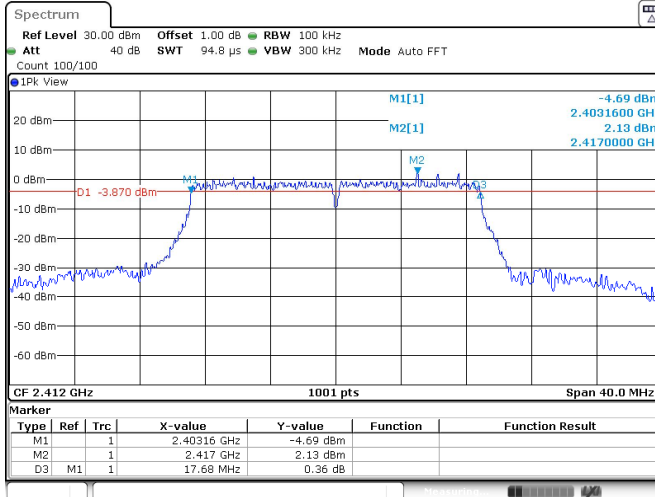

Date: 8 APR 2022 15:54:40

11N20SISO\_Ant1\_2437

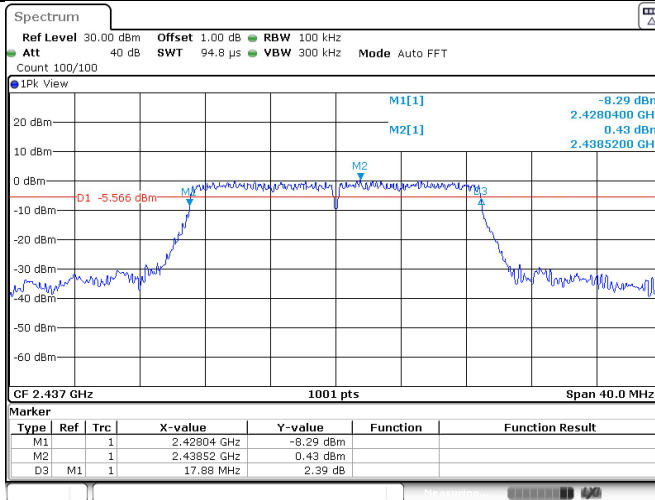

Date: 8 APR 2022 16:08:04

11N20SISO\_Ant1\_2462

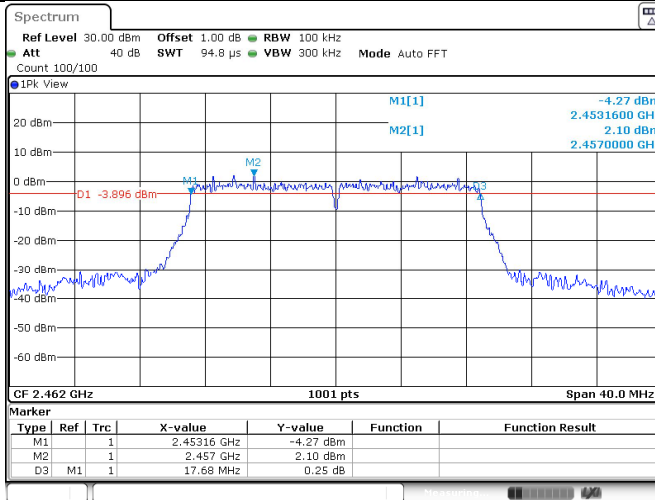

Date: 8 APR 2022 16:10:13



## 8.4 Power spectral density

### Test Method

This procedure shall be used if maximum peak conducted output power was used to demonstrate compliance:

1. Set analyzer center frequency to DTS channel center frequency. RBW=3kHz, VBW≥3RBW, Span=1.5 times DTS bandwidth, Detector=Peak, Sweep=auto, Trace= max hold.
2. Allow trace to fully stabilize, use the peak marker function to determine the maximum amplitude level within the RBW.
3. Repeat above procedures until other frequencies measured were completed.

### Limit

**Limit [dBm/3kHz]**

≤8

TestMode	Antenna	Channel(MHz)	Result(dBm/3kHz)	Limit(dBm/3kHz)	Verdict
11B	Ant1	2412	-11.35	≤8	PASS
		2437	-11.73	≤8	PASS
		2462	-12.35	≤8	PASS
11G	Ant1	2412	-13.44	≤8	PASS
		2437	-13.51	≤8	PASS
		2462	-13.4	≤8	PASS
11N20SISO	Ant1	2412	-12.99	≤8	PASS
		2437	-12.65	≤8	PASS
		2462	-13.51	≤8	PASS



11B\_Ant1\_2412

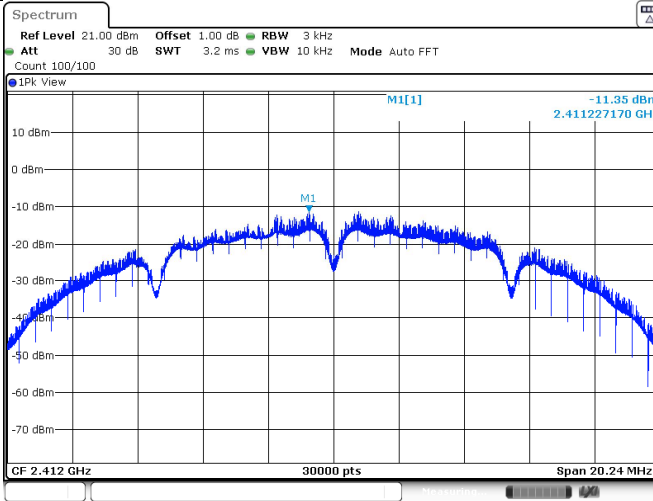

Date: 8 APR 2022 15:34:37

11B\_Ant1\_2437

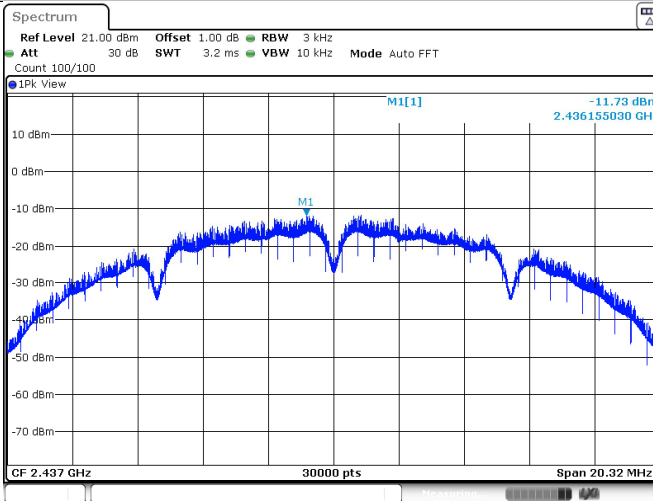

Date: 8 APR 2022 15:36:48

11B\_Ant1\_2462

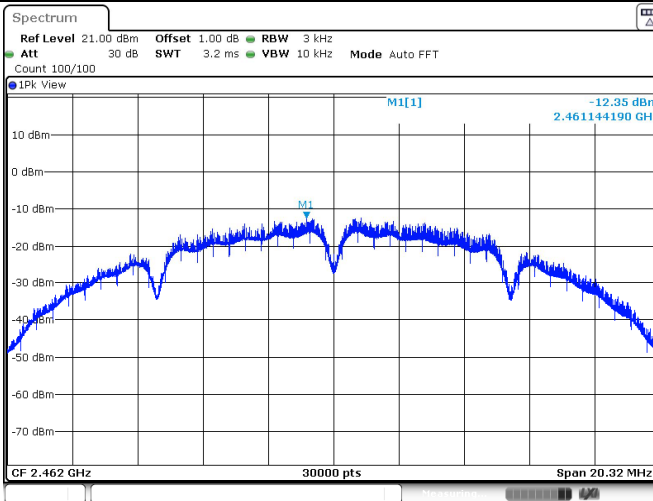

Date: 8 APR 2022 15:39:09

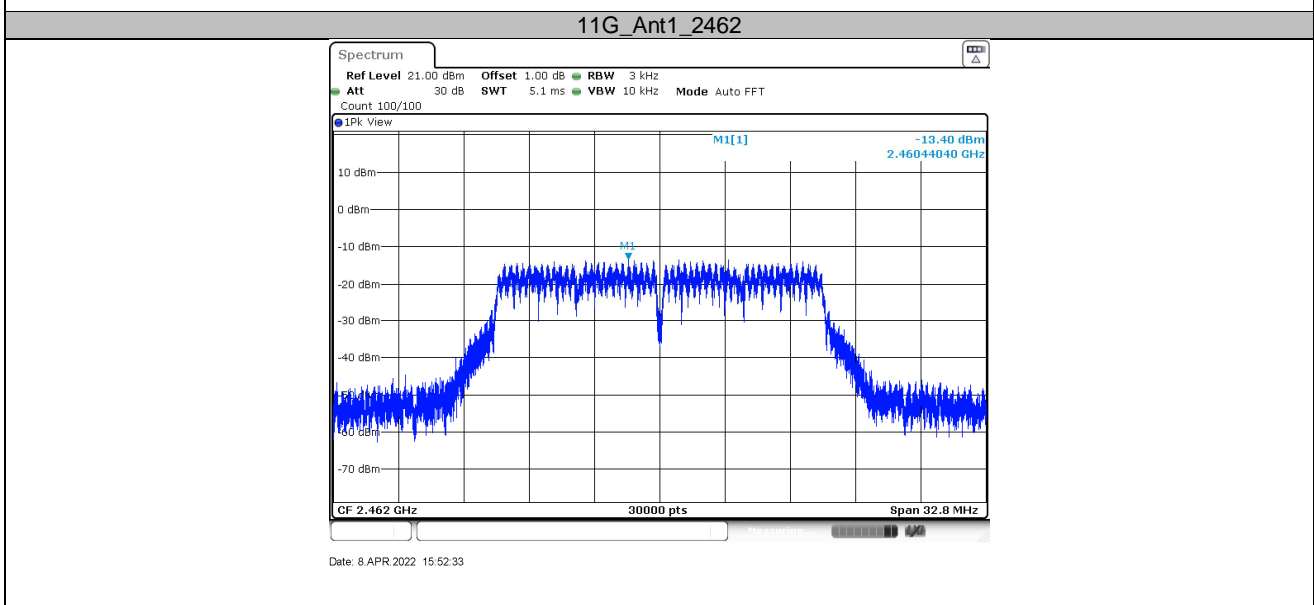
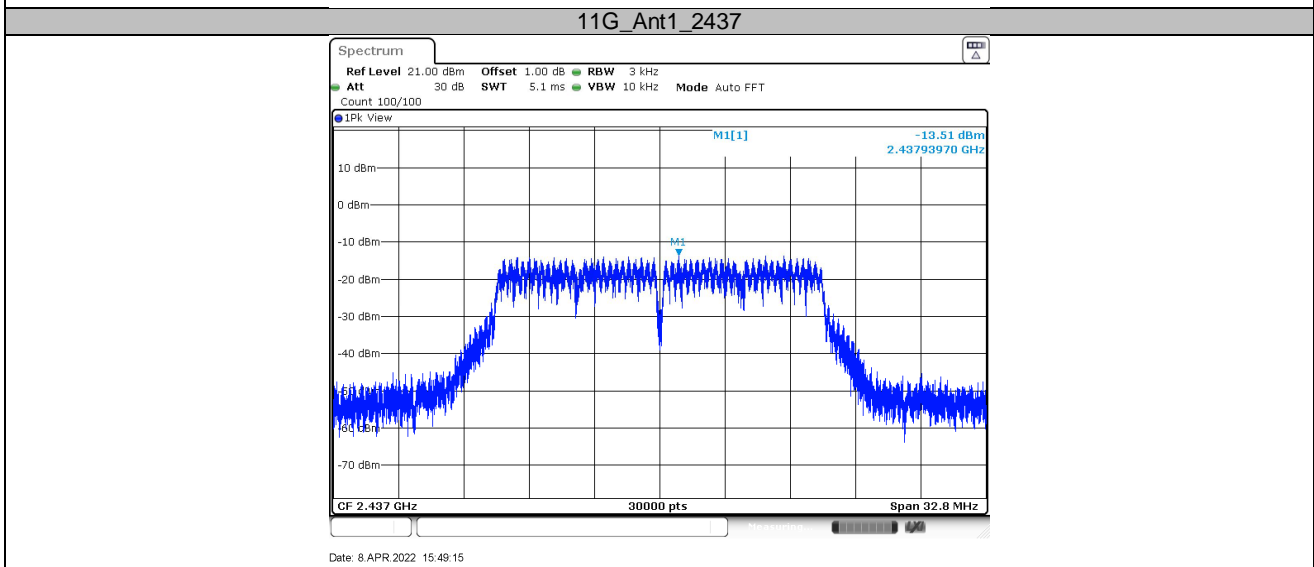
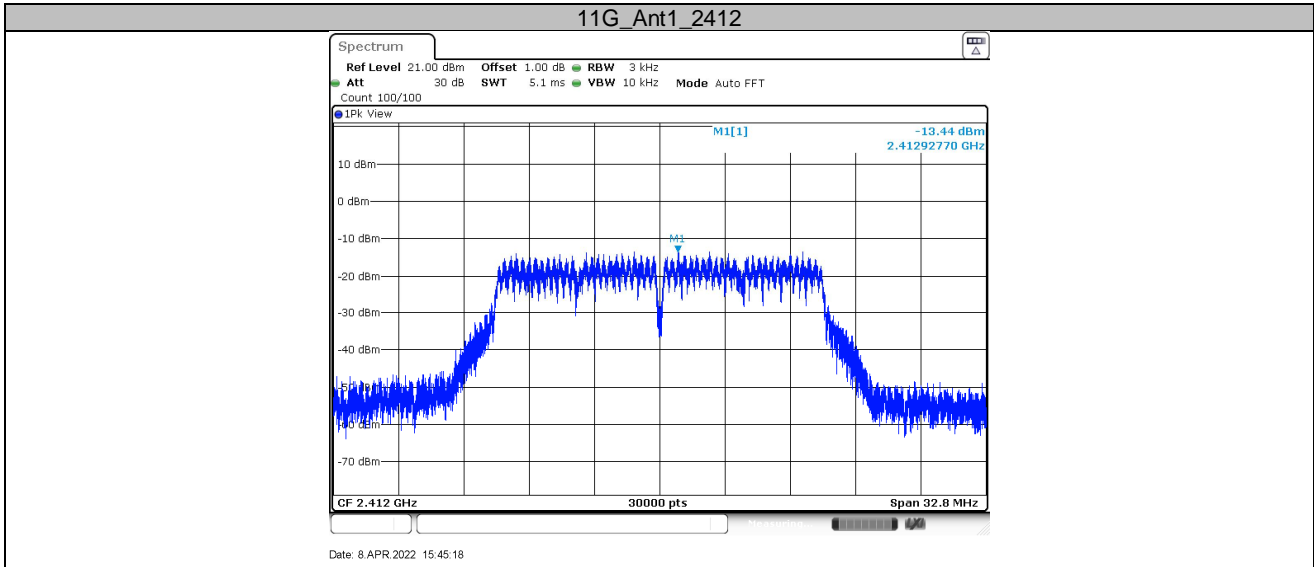

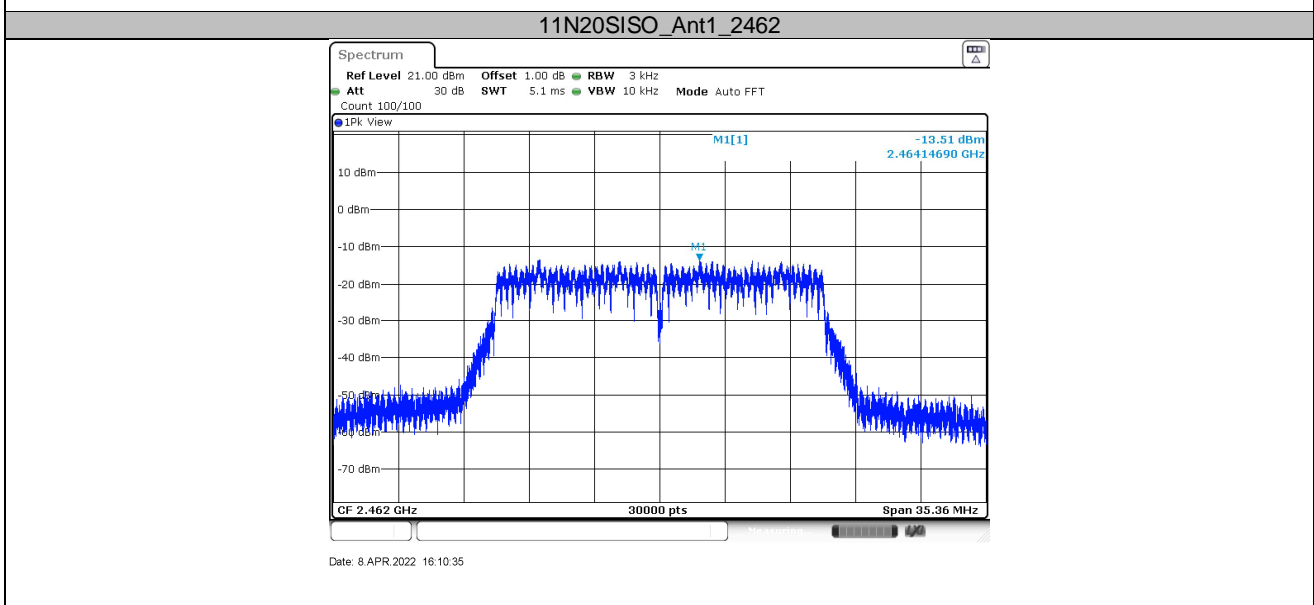
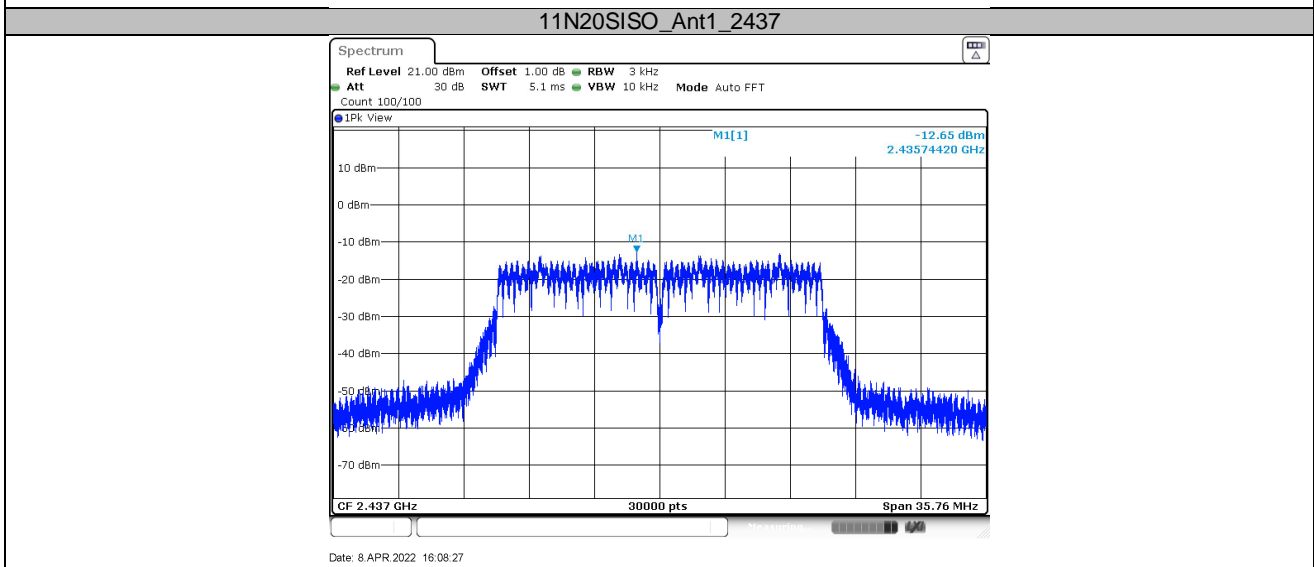
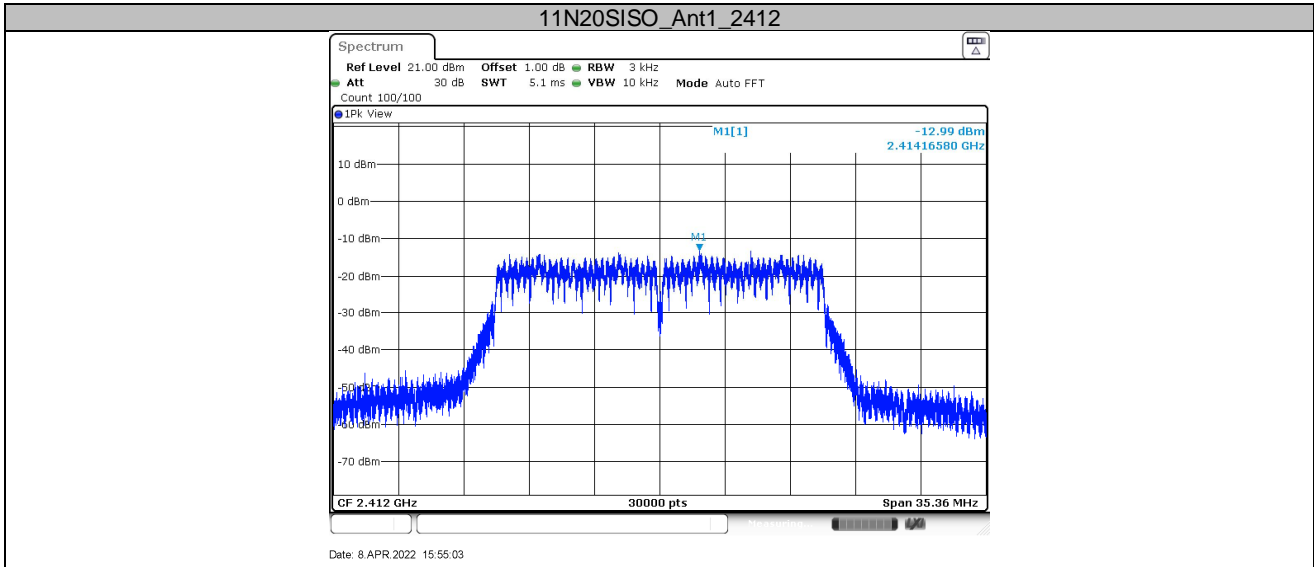

## 8.5 Spurious RF conducted emissions

### Test Method

- Use the following spectrum analyzer settings:  
Span = wide enough to capture the peak level of the in-band emission and all spurious emissions (e.g., harmonics) from the lowest frequency generated in the EUT up through the 10<sup>th</sup> harmonic. Typically, several plots are required to cover this entire span.  
RBW = 100 kHz, VBW ≥ RBW, Sweep = auto, Detector function = peak, Trace = max hold
- Allow the trace to stabilize. Set the marker on the peak of any spurious emission recorded.
- The level displayed must comply with the limit specified in this Section. Submit these plots.
- Repeat above procedures until all frequencies measured were complete.

### Limit

Frequency Range MHz	Limit (dBc)
30-25000	-20

TestMode	Antenna	Channel	FreqRange(MHz)	RefLevel	Result(dBm)	Limit(dBm)	Verdict
11B	Ant1	2412	Reference	4.94	4.94	---	PASS
			30~1000	30~1000	-67.48	<=-15.06	PASS
			1000~26500	1000~26500	-31.64	<=-15.06	PASS
		2437	Reference	5.04	5.04	---	PASS
			30~1000	30~1000	-67.97	<=-14.96	PASS
			1000~26500	1000~26500	-51.24	<=-14.96	PASS
		2462	Reference	5.15	5.15	---	PASS
			30~1000	30~1000	-68.3	<=-14.85	PASS
			1000~26500	1000~26500	-51.88	<=-14.85	PASS
11G	Ant1	2412	Reference	0.34	0.34	---	PASS
			30~1000	30~1000	-67.32	<=-19.66	PASS
			1000~26500	1000~26500	-33.58	<=-19.66	PASS
		2437	Reference	0.15	0.15	---	PASS
			30~1000	30~1000	-67.7	<=-19.85	PASS
			1000~26500	1000~26500	-49.55	<=-19.85	PASS
		2462	Reference	0.38	0.38	---	PASS
			30~1000	30~1000	-68.57	<=-19.62	PASS
			1000~26500	1000~26500	-44.6	<=-19.62	PASS
11N20SISO	Ant1	2412	Reference	-0.31	-0.31	---	PASS
			30~1000	30~1000	-66.42	<=-20.31	PASS
			1000~26500	1000~26500	-31.17	<=-20.31	PASS
		2437	Reference	0.35	0.35	---	PASS
			30~1000	30~1000	-67.18	<=-19.65	PASS
			1000~26500	1000~26500	-52.02	<=-19.65	PASS
		2462	Reference	-0.01	-0.01	---	PASS
			30~1000	30~1000	-66.84	<=-20.01	PASS
			1000~26500	1000~26500	-52.17	<=-20.01	PASS
30~1000	30~1000		-60.94	<=-18.63	PASS		
			1000~26500	1000~26500	-27.84	<=-18.63	PASS

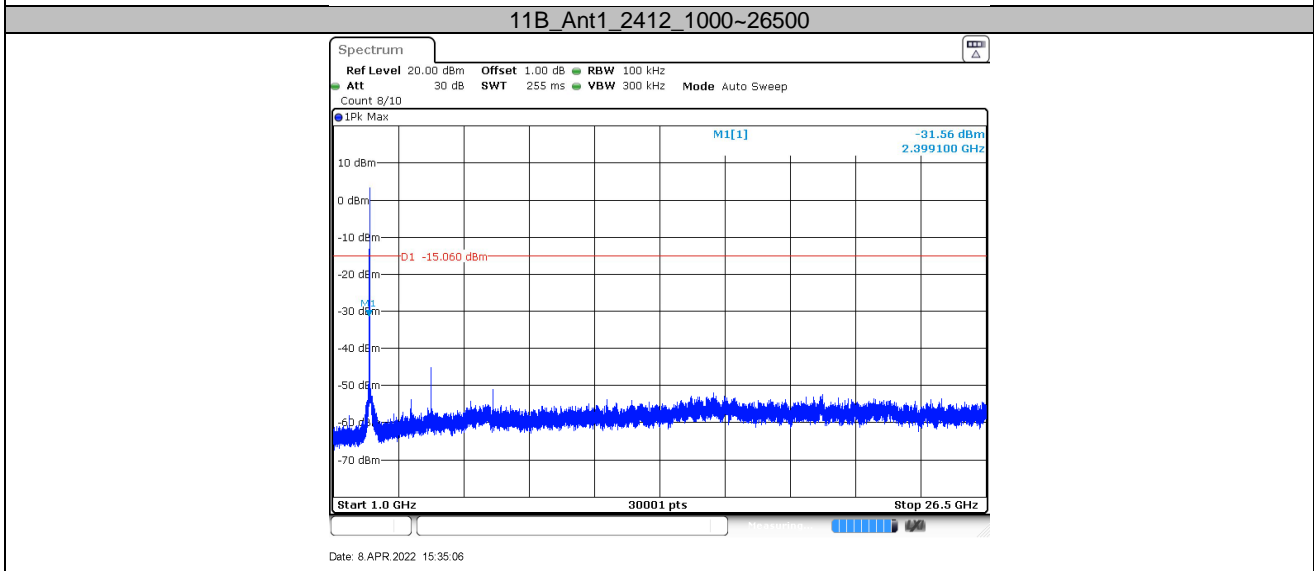
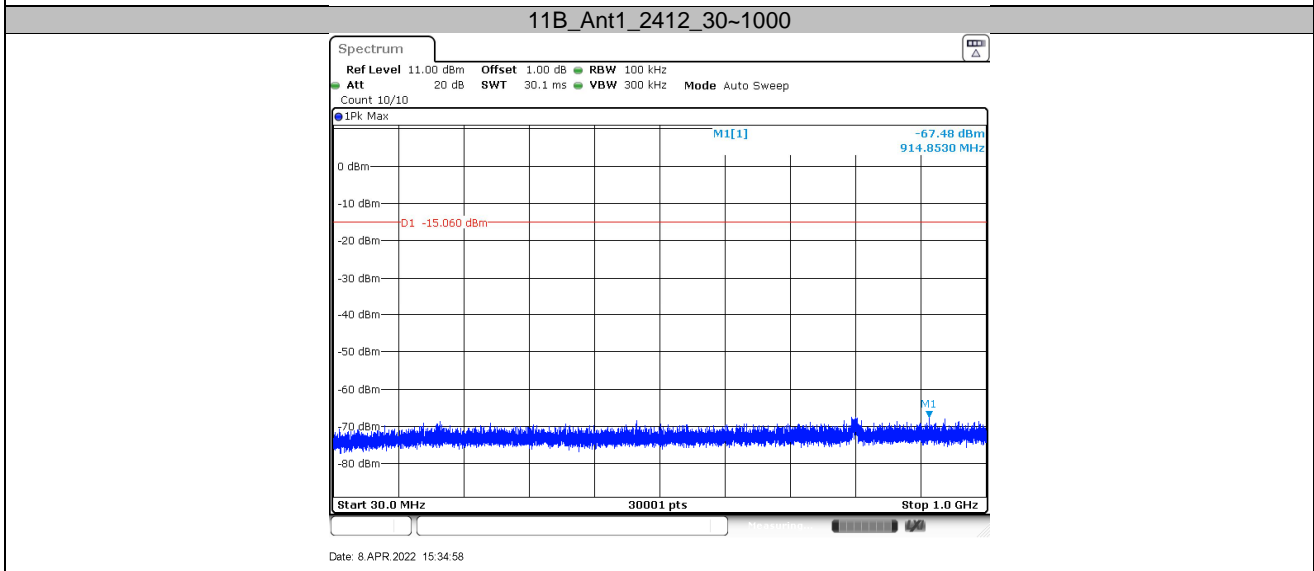
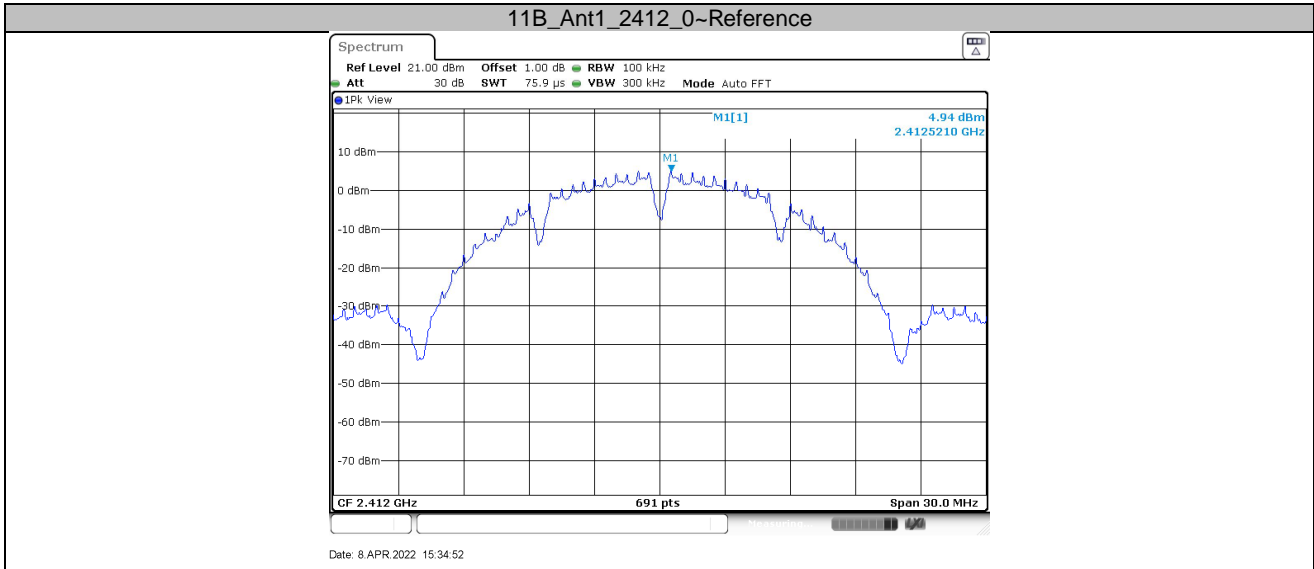

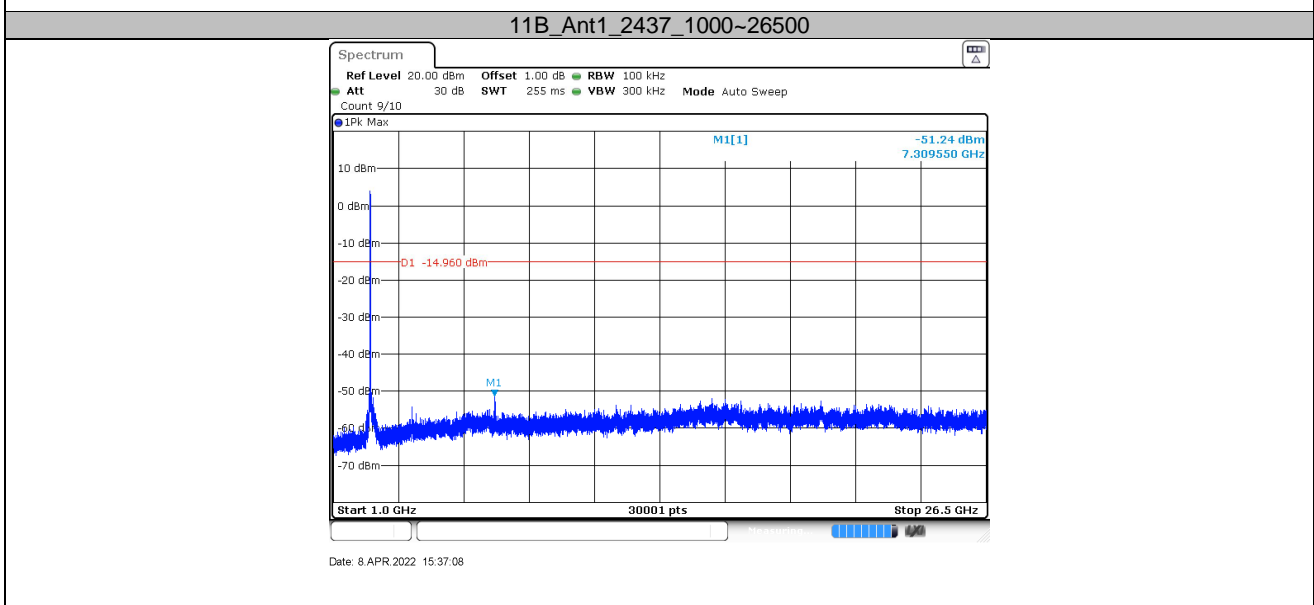
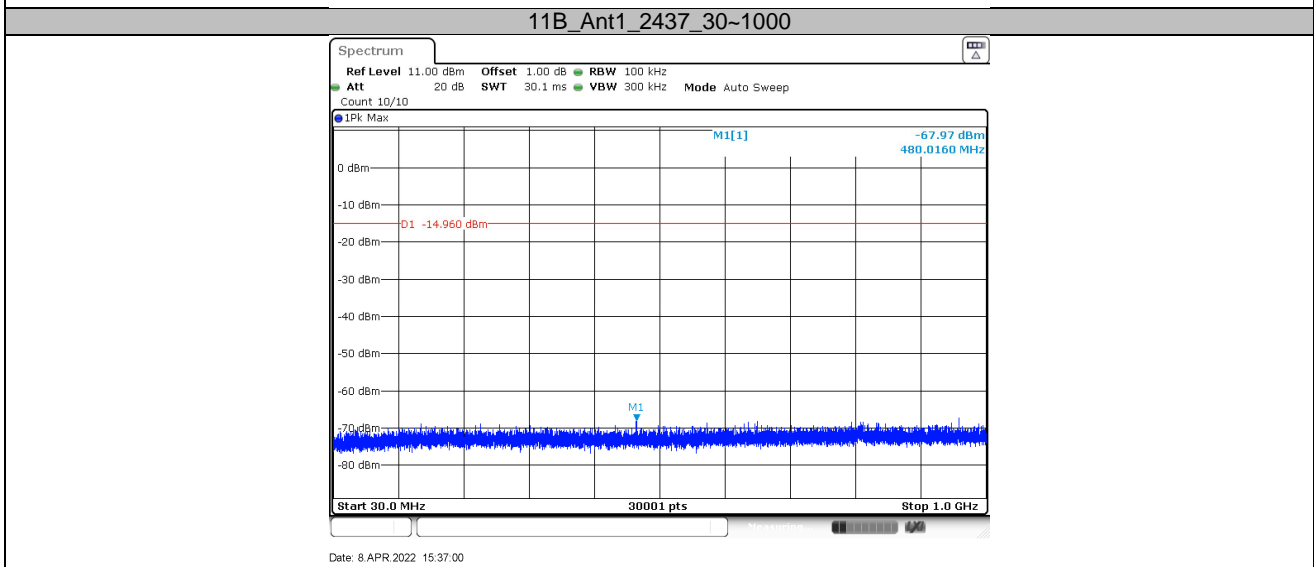
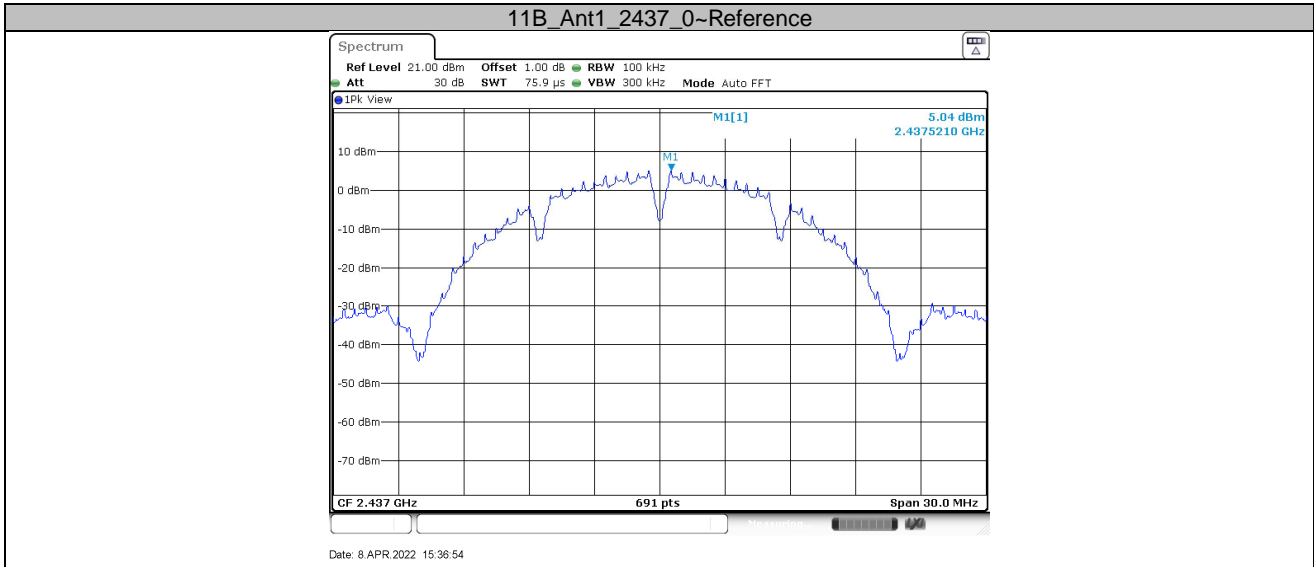



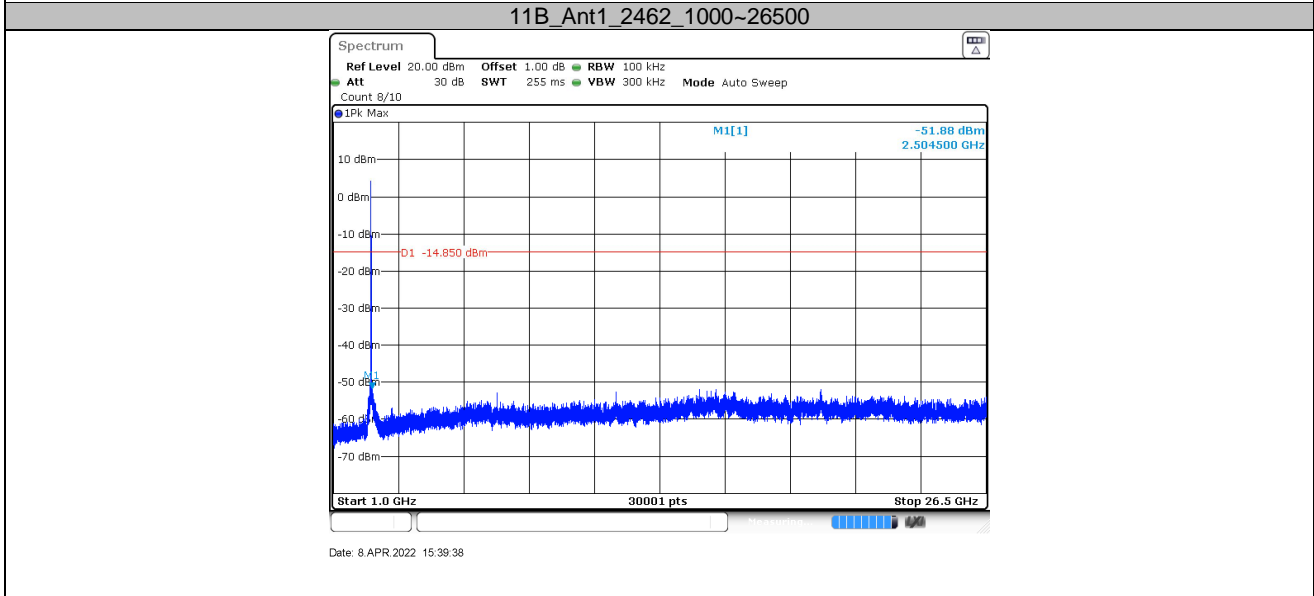
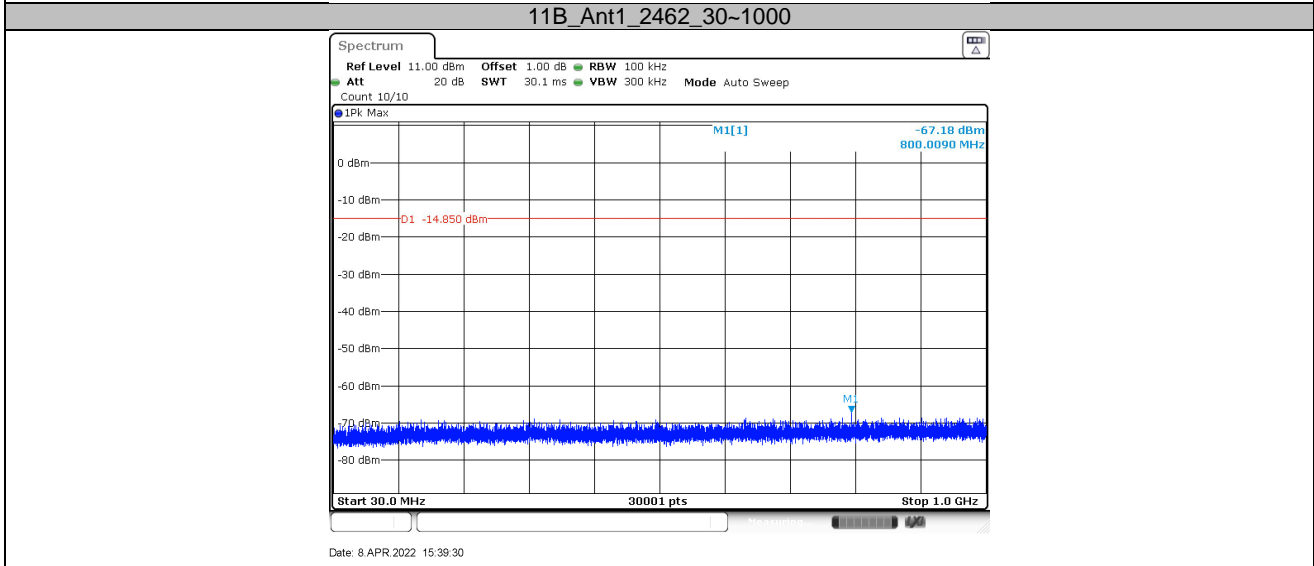
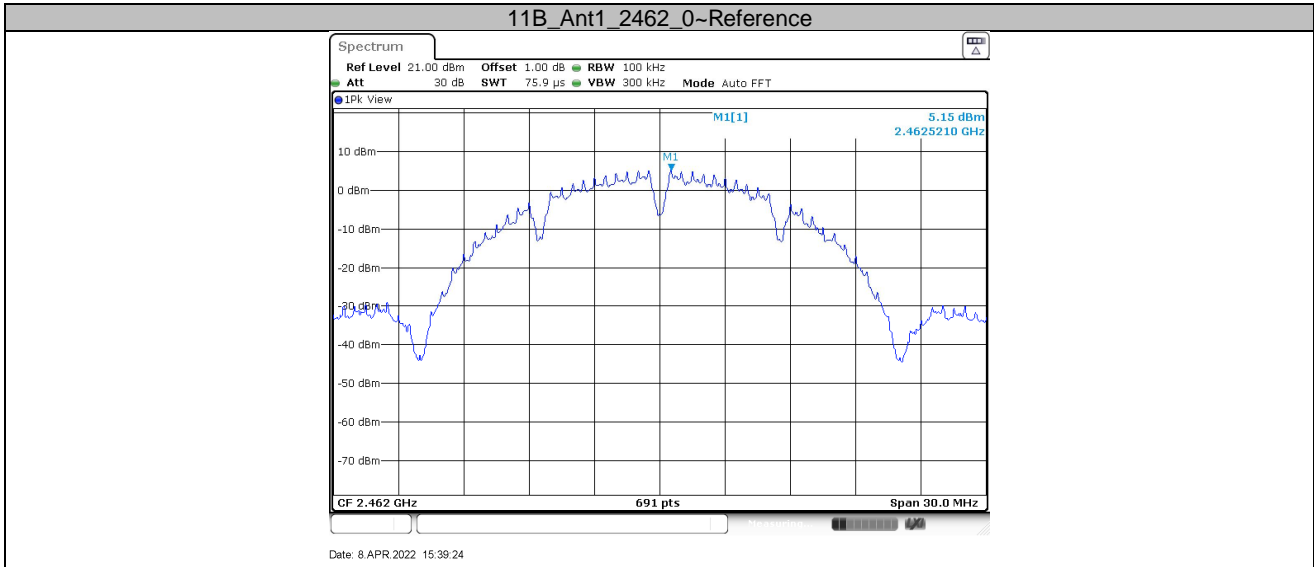

11G\_Ant1\_2412\_0~Reference

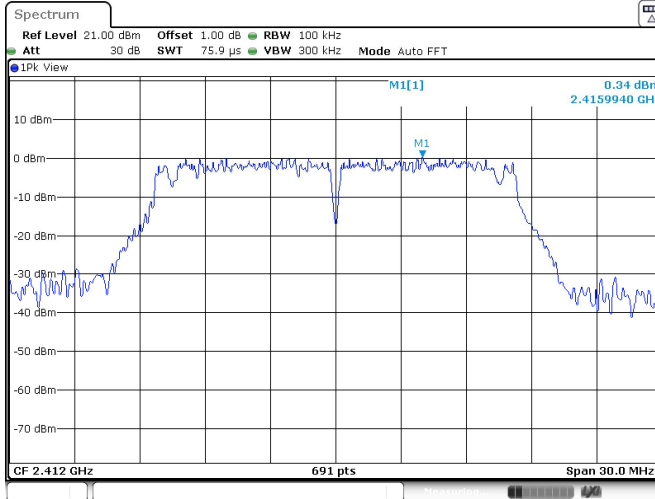

Date: 8 APR 2022 15:45:32

11G\_Ant1\_2412\_30~1000

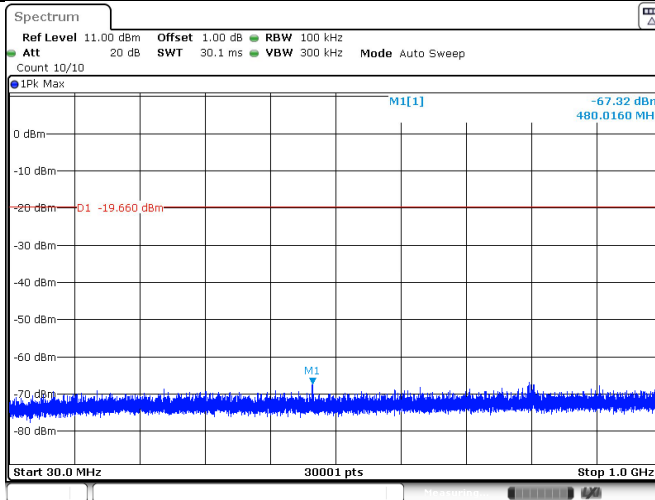

Date: 8 APR 2022 15:45:39

11G\_Ant1\_2412\_1000~26500

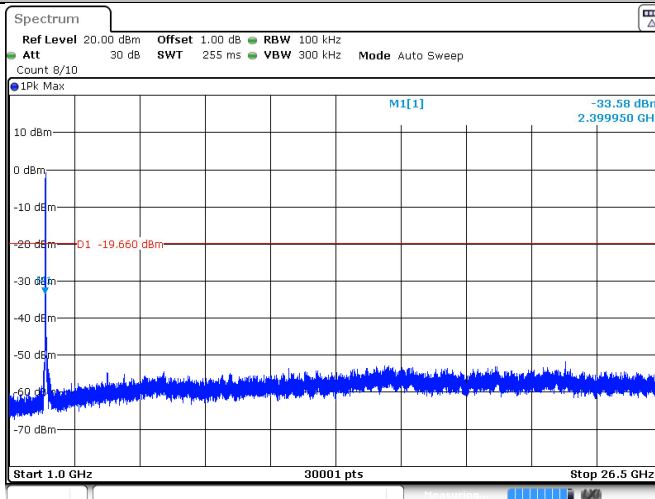

Date: 8 APR 2022 15:45:46

### 11G\_Ant1\_2437\_0~Reference

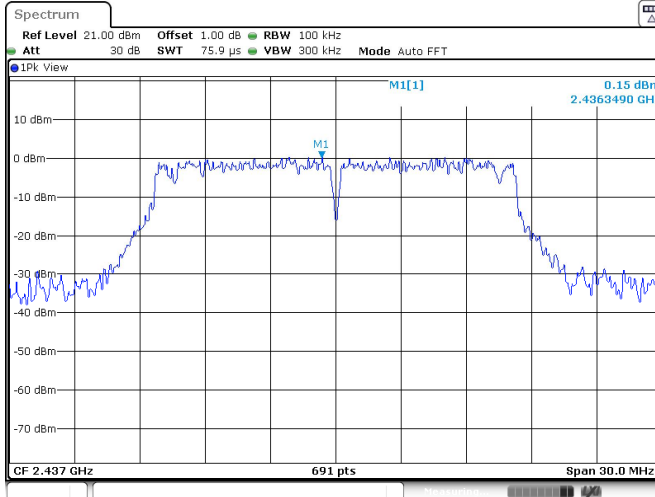

Date: 8 APR 2022 15:49:20

### 11G\_Ant1\_2437\_30~1000

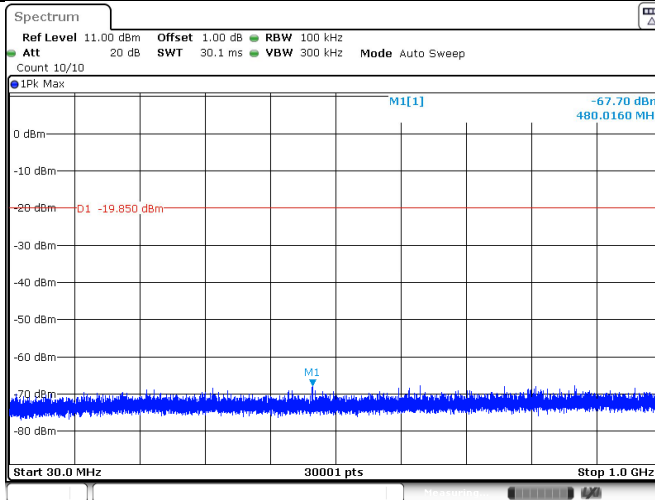

Date: 8 APR 2022 15:49:26

### 11G\_Ant1\_2437\_1000~26500

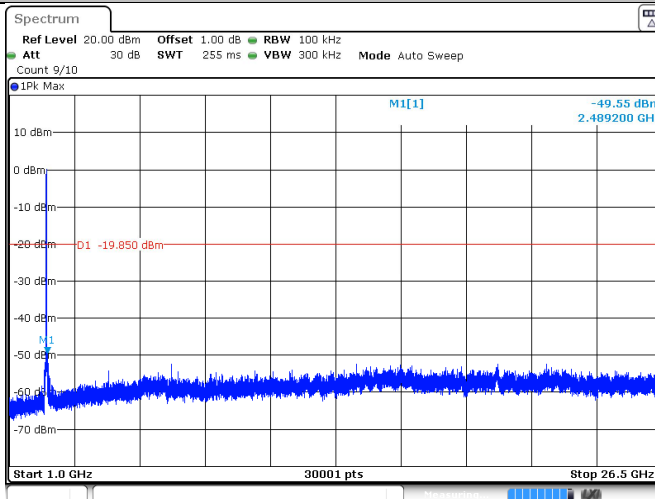

Date: 8 APR 2022 15:49:34

11G\_Ant1\_2462\_0~Reference

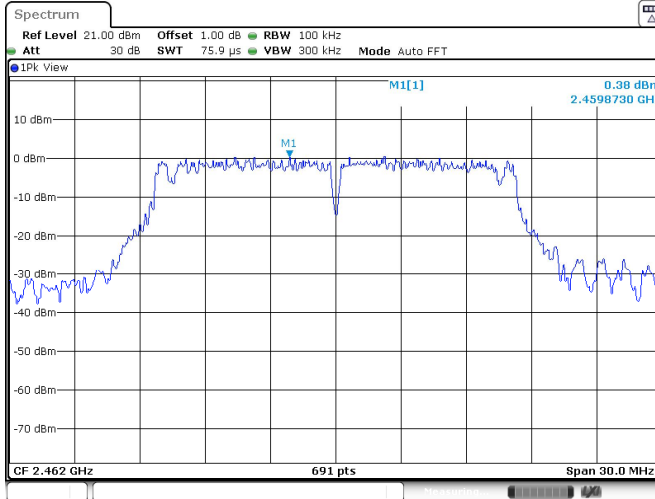

Date: 8 APR 2022 15:52:47

11G\_Ant1\_2462\_30~1000

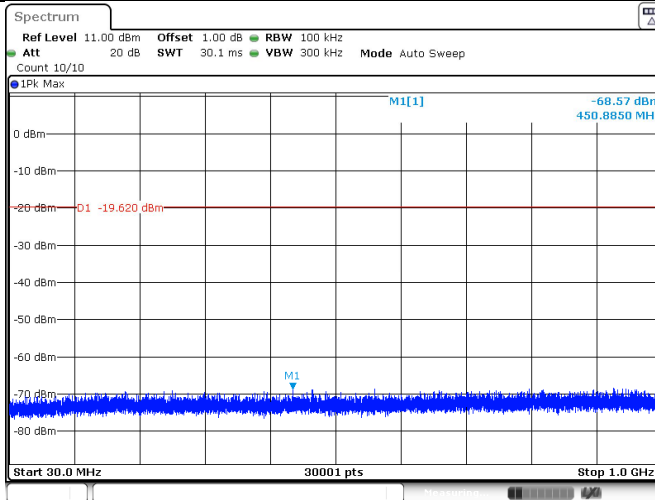

Date: 8 APR 2022 15:52:54

11G\_Ant1\_2462\_1000~26500

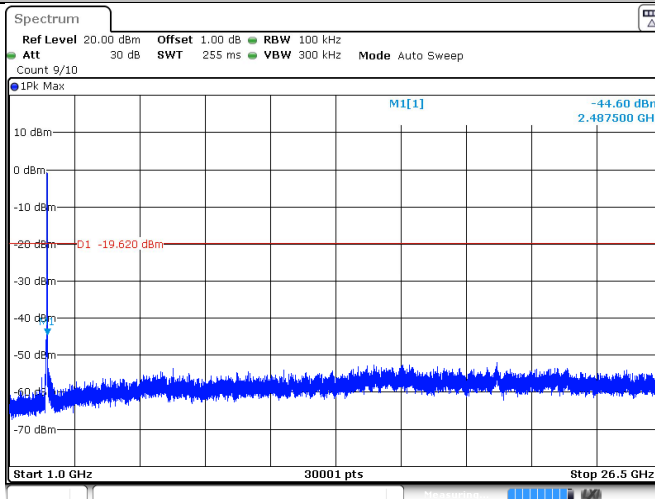

Date: 8 APR 2022 15:53:01

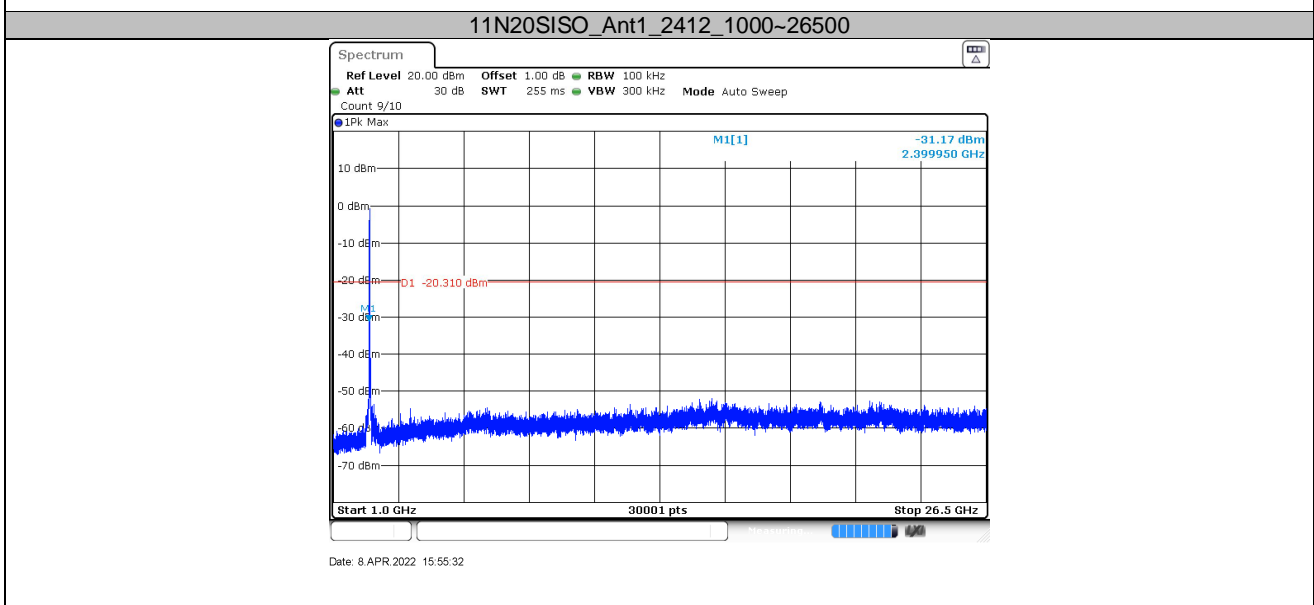
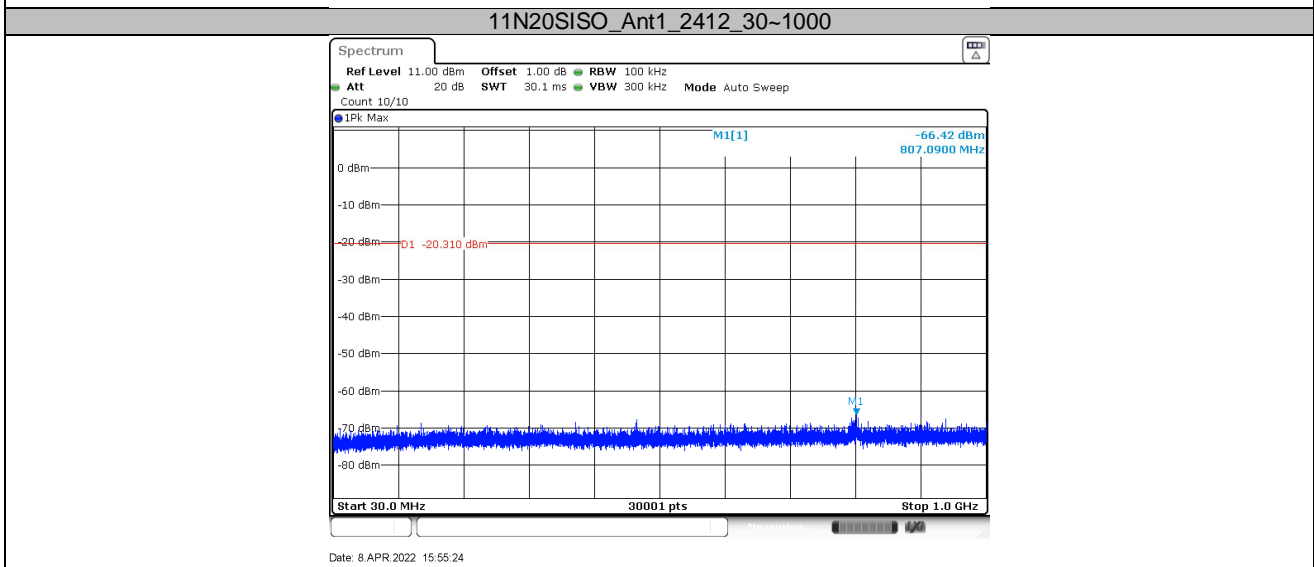
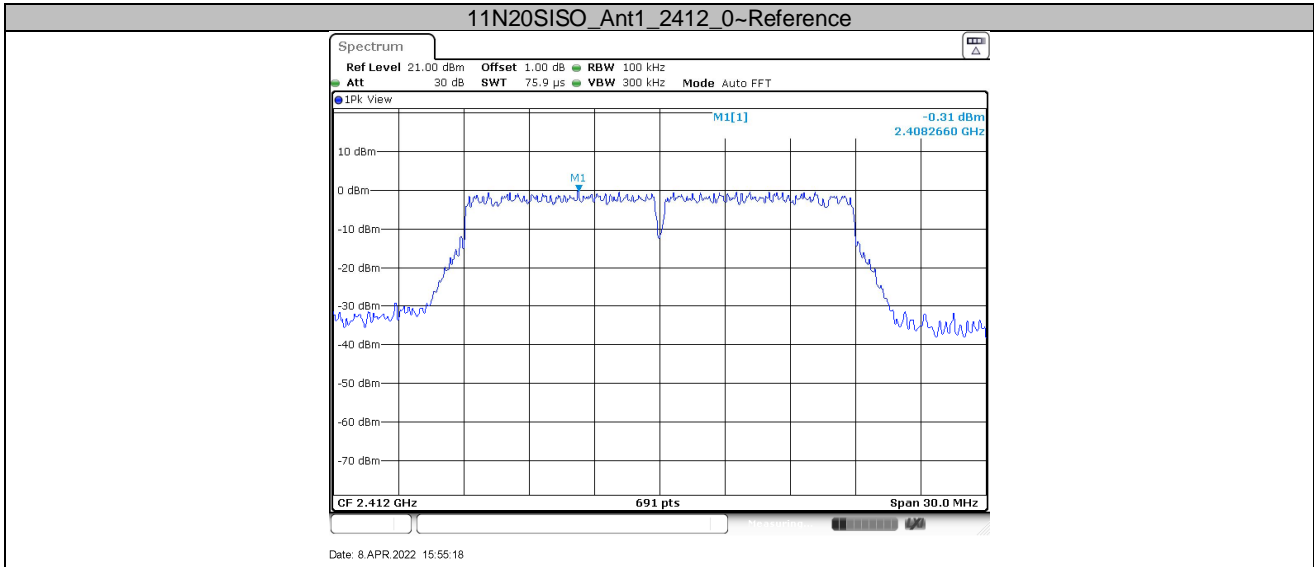

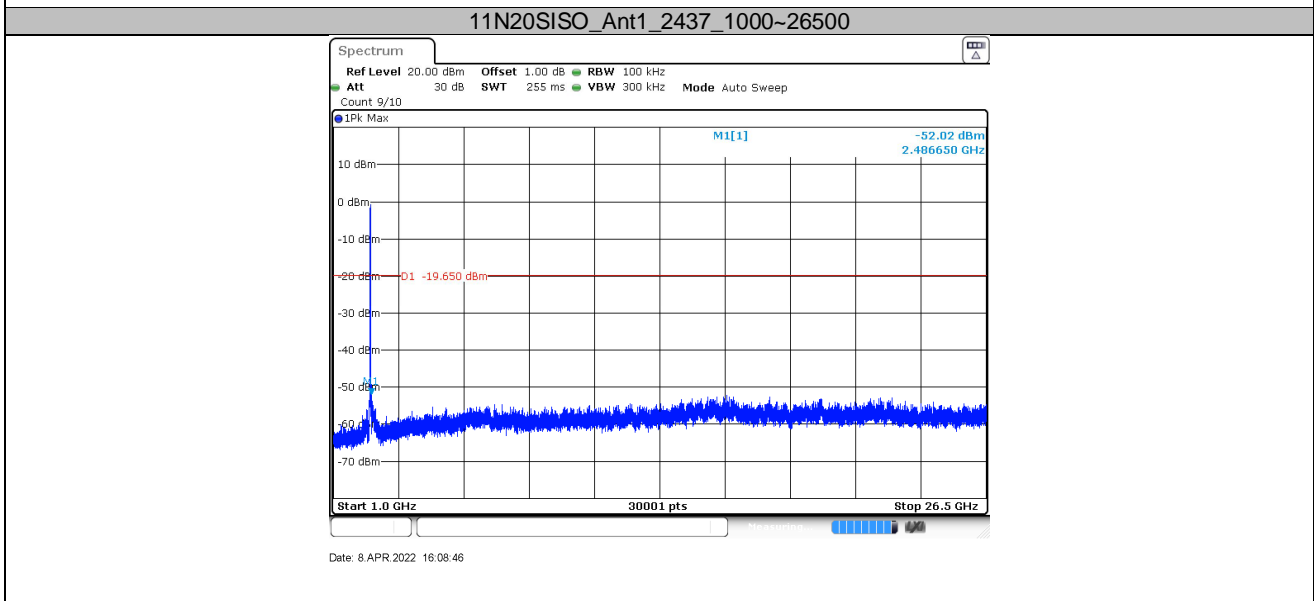
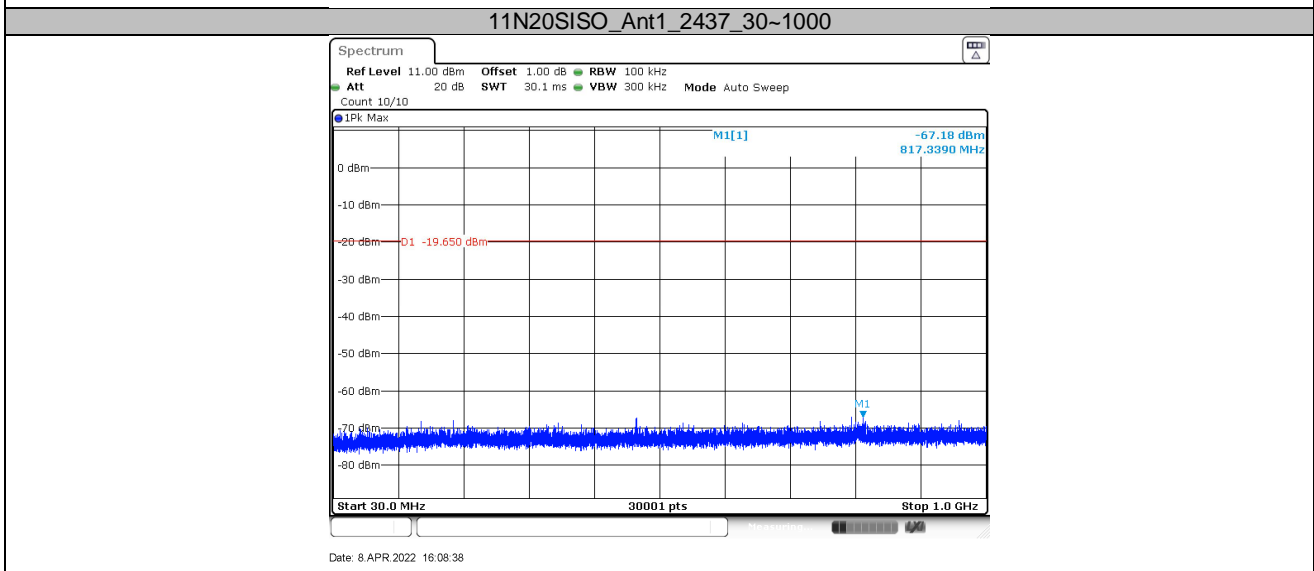
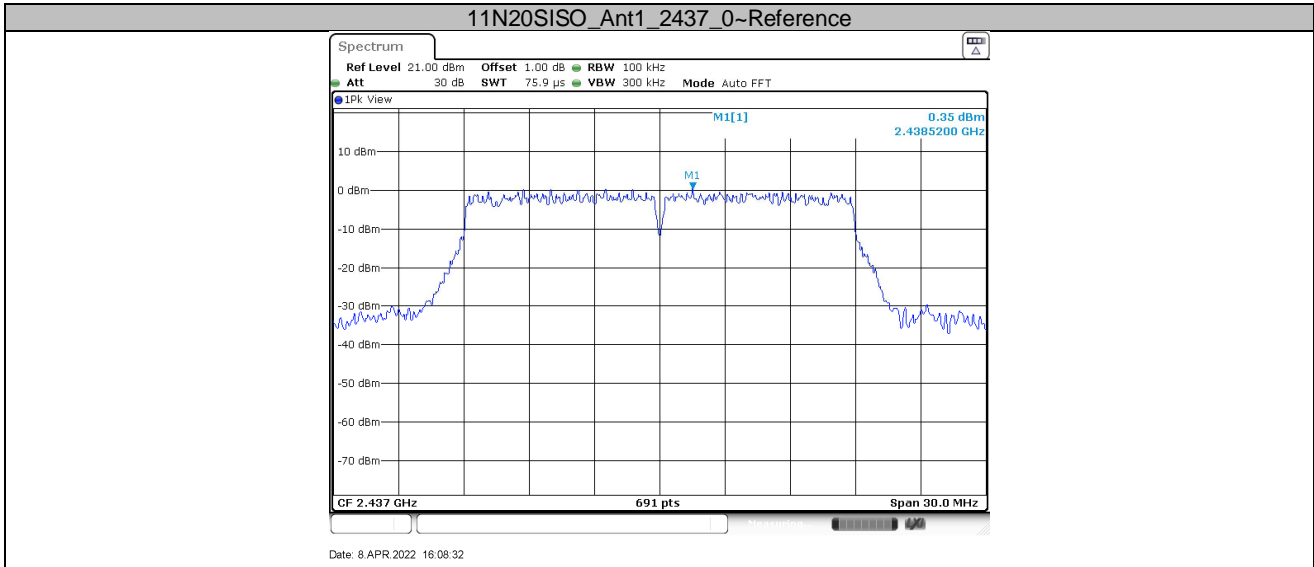

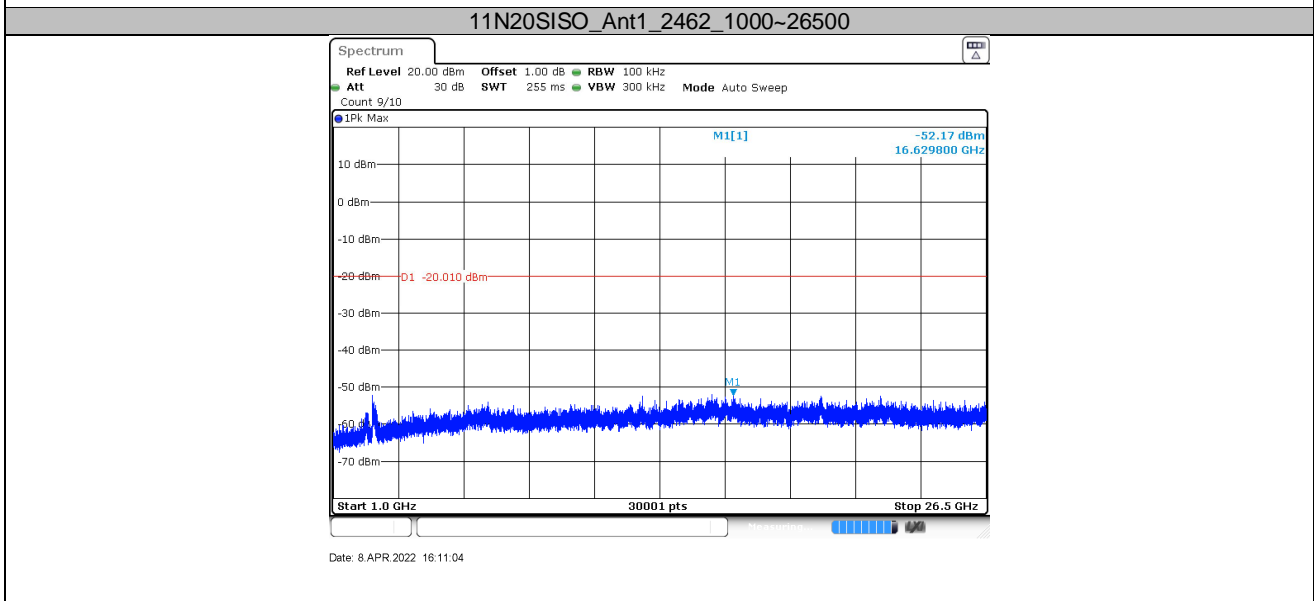
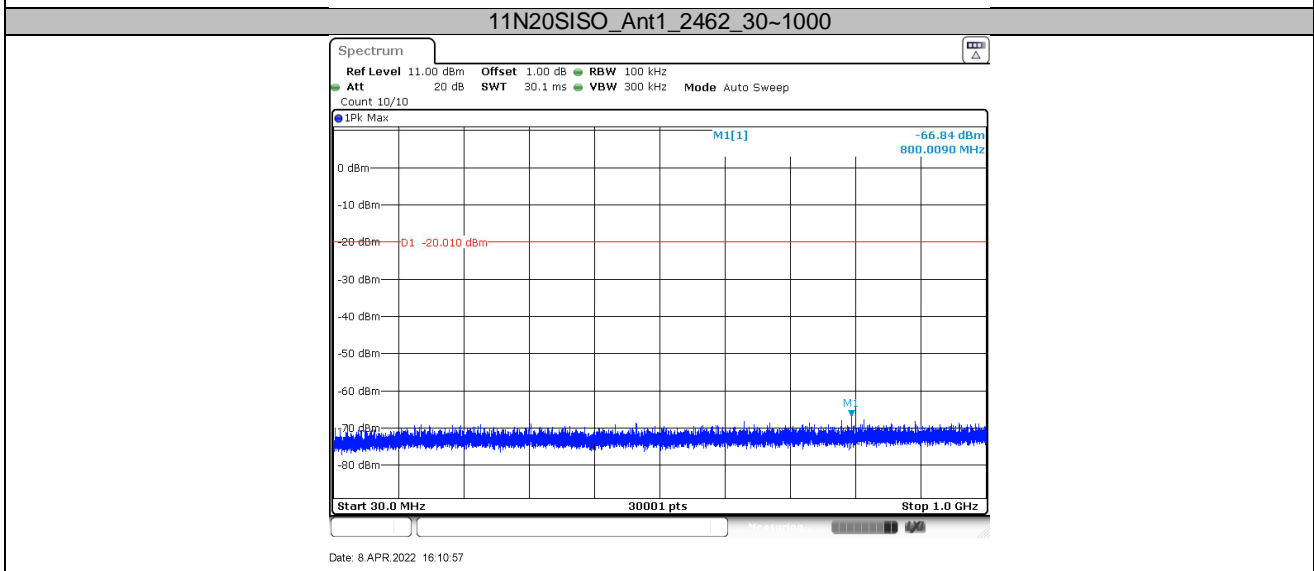
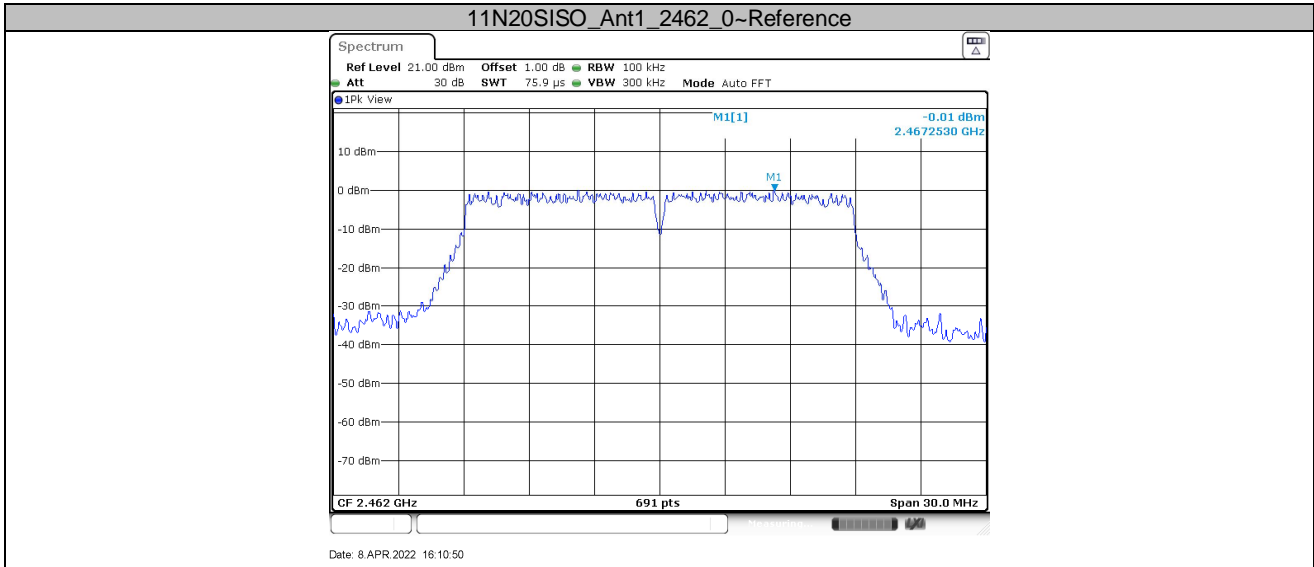



## 8.6 Band edge testing

### Test Method

- 1 Use the following spectrum analyzer settings:  
Span = wide enough to capture the peak level of the in-band emission and all spurious  
RBW = 100 kHz, VBW ≥ RBW, Sweep = auto, Detector function = peak, Trace = max hold
- 2 Allow the trace to stabilize, use the peak and delta measurement to record the result.
- 3 The level displayed must comply with the limit specified in this Section. .
- 4 Repeat the test at the hopping off and hopping on mode, submit all the plots.

### Limit:

According to §15.247(d), in any 100 kHz bandwidth outside the frequency bands in which the spread spectrum intentional radiator is operating, the radio frequency power that is produced by the intentional radiator shall be at least 20 dB below that in the 100 kHz bandwidth within the band that contains the highest level of the desired power, based on either an RF conducted or a radiated measurement, provided the transmitter demonstrates compliance with the peak conducted power limits. In addition, radiated emissions which fall in the restricted bands, as defined in §15.205(a), must also comply with the radiated emission limits specified in 15.209(a) (see Section 15.205(c)).

Frequency Range MHz	Limit (dBc)
30-25000	-20

### Test result

TestMode	Antenna	ChName	Channel	RefLevel	Result	Limit	Verdict
11B	Ant1	Low	2412	4.55	-30.77	<=-15.45	PASS
		High	2462	4.86	-49.18	<=-15.14	PASS
11G	Ant1	Low	2412	-0.09	-32.75	<=-20.09	PASS
		High	2462	3.49	-39.66	<=-16.51	PASS
11N20SISO	Ant1	Low	2412	-0.41	-31.54	<=-20.41	PASS
		High	2462	-0.27	-40.21	<=-20.27	PASS



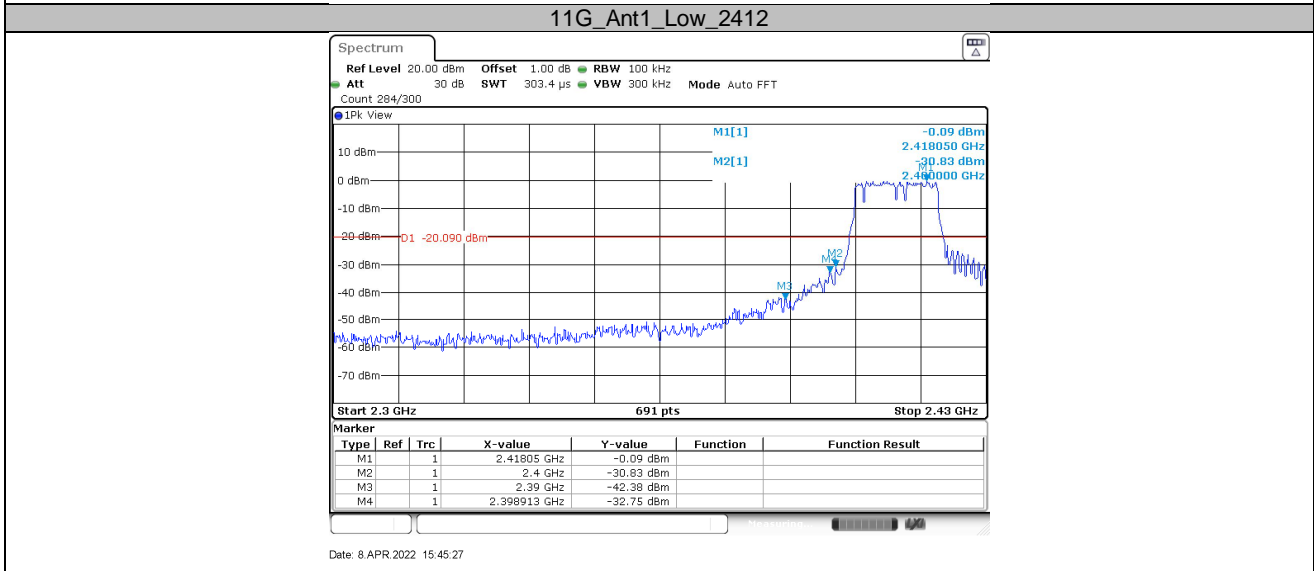
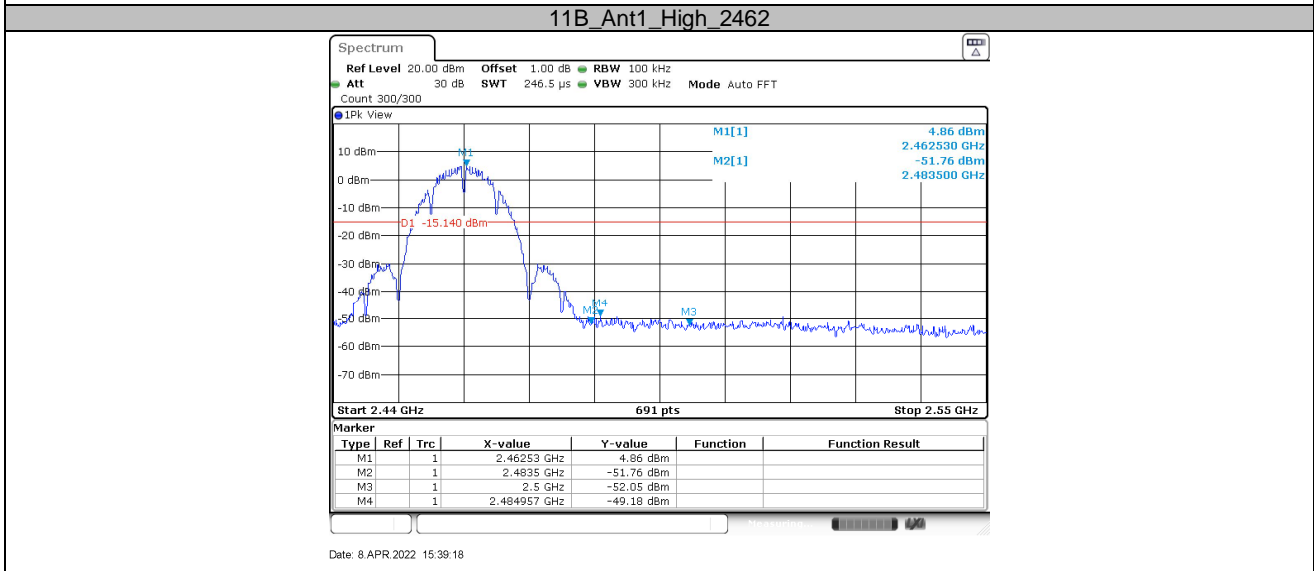
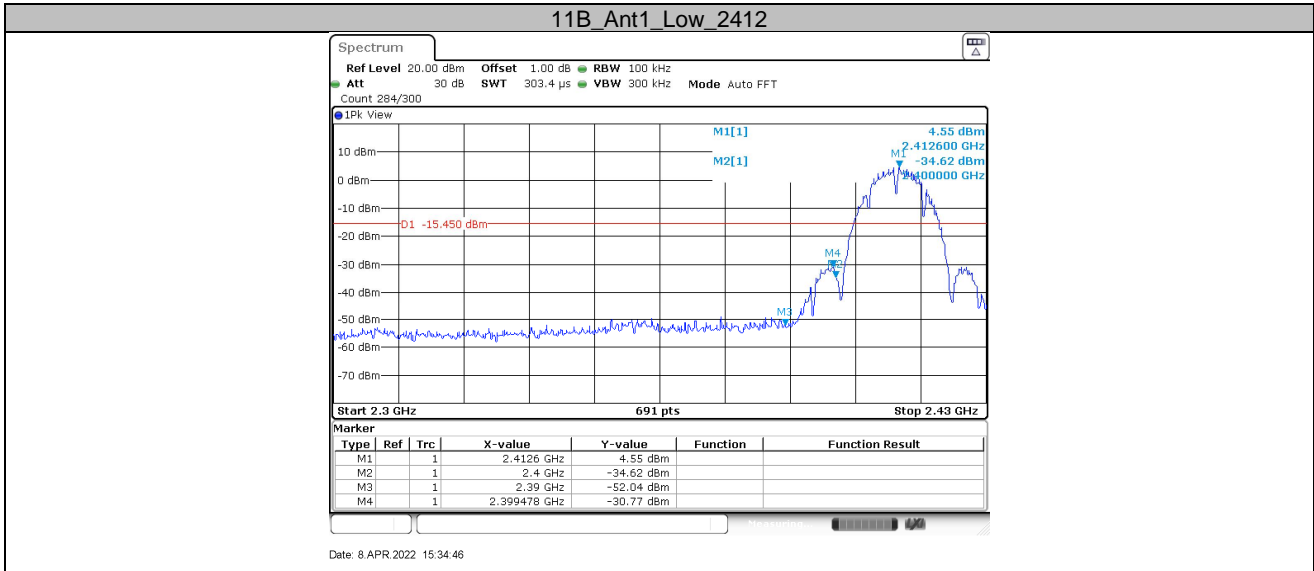



### 11G\_Ant1\_High\_2462

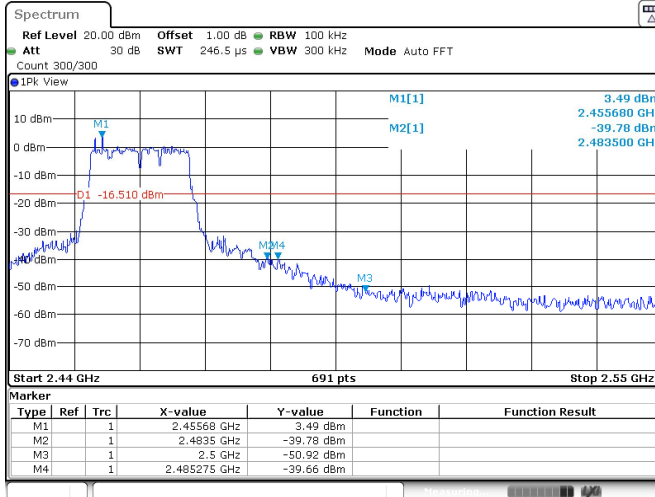

Date: 8 APR 2022 15:52:42

### 11N20SISO\_Ant1\_Low\_2412

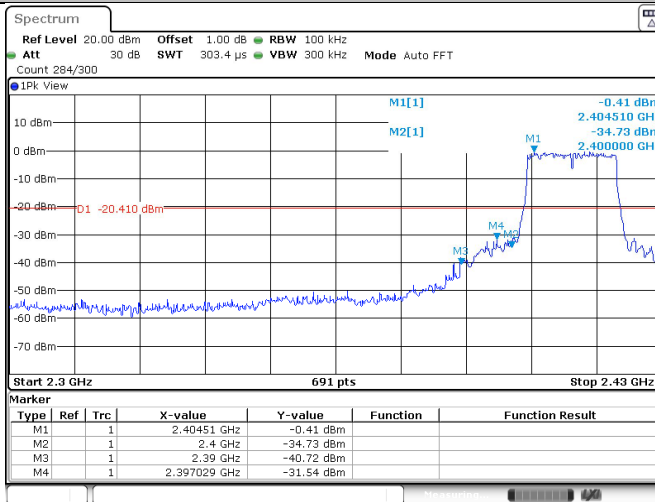

Date: 8 APR 2022 15:55:12

### 11N20SISO\_Ant1\_High\_2462

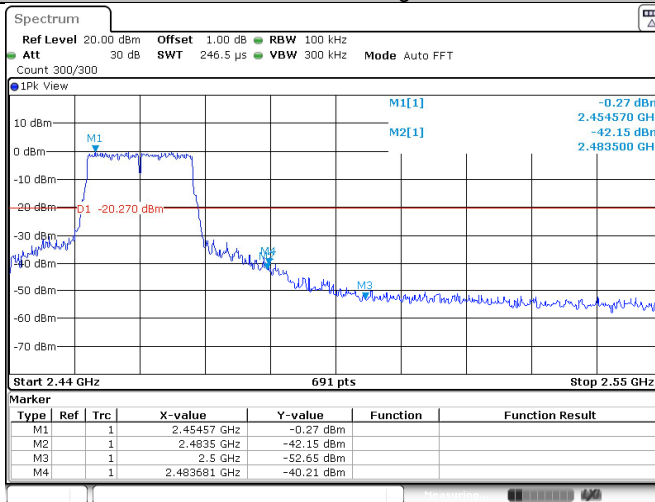

Date: 8 APR 2022 16:10:45

## 8.7 Spurious radiated emissions for transmitter

### Test Method

1. The EUT was placed on a turn table which is 1.5m above ground plane for above 1GHz and 0.8m above ground for below 1GHz at 3meter chamber room for test. The table was rotated 360 degrees to determine the position of the highest radiation.
2. The EUT was set 3 meters away from the interference – receiving antenna, which was mounted on the top of a variable – height antenna tower.
3. The height of antenna is varied from one meter to four meters above the ground to determine the maximum value of the field strength. Both horizontal and vertical polarizations of the antenna are set to make the measurement.
4. For each suspected emission, the EUT was arranged to its worst case and then the antenna was tuned to heights from 1 meter to 4 meters and the rotatable table was turned
5. Use the following spectrum analyzer settings According to C63.10:  
For Below 1GHz  
Use the following spectrum analyzer settings:  
Span = wide enough to capture the peak level of the in-band emission and all spurious  
RBW = 100 kHz to 120 kHz, VBW $\geq$ RBW for peak measurement, Sweep = auto,  
Detector function = peak, Trace = max hold.

For Peak unwanted emissions Above 1GHz:

Span = wide enough to capture the peak level of the in-band emission and all spurious  
RBW = 1MHz, VBW $\geq$ RBW for peak measurement, Sweep = auto, Detector function = peak, Trace = max hold.

Procedures for average unwanted emissions measurements above 1000 MHz

- a) RBW = 1MHz.
- b) VBW  $\geq$  [3  $\times$  RBW].
- c) Detector = RMS (power averaging), if [span / (# of points in sweep)]  $\leq$  RBW / 2.  
Satisfying this condition can require increasing the number of points in the sweep or reducing the span. If the condition is not satisfied, then the detector mode shall be set to peak.
- d) Averaging type = power (i.e., rms) (As an alternative, the detector and averaging type may be set for linear voltage averaging. Some instruments require linear display mode to use linear voltage averaging. Log or dB averaging shall not be used.)
- e) Sweep time = auto.
- f) Perform a trace average of at least 100 traces if the transmission is continuous. If the transmission is not continuous, then the number of traces shall be increased by a factor of 1 / D, where D is the duty cycle. For example, with 50% duty cycle, at least 200 traces shall be averaged. (If a specific emission is demonstrated to be continuous—i.e., 100% duty cycle—then rather than turning ON and OFF with the transmit cycle, at least 100 traces shall be averaged.)
- g) If tests are performed with the EUT transmitting at a duty cycle less than 98%, then a correction factor shall be added to the measurement results prior to comparing with the emission limit, to compute the emission level that would have been measured had the test been performed at 100% duty cycle. The correction factor is computed as follows:



- 1) If power averaging (rms) mode was used in the preceding step e), then the correction factor is  $[10 \log (1 / D)]$ , where D is the duty cycle. For example, if the transmit duty cycle was 50%, then 3 dB shall be added to the measured emission levels.
- 2) If linear voltage averaging mode was used in the preceding step e), then the correction factor is  $[20 \log (1 / D)]$ , where D is the duty cycle. For example, if the transmit duty cycle was 50%, then 6 dB shall be added to the measured emission levels.
- 3) If a specific emission is demonstrated to be continuous (100% duty cycle) rather than turning ON and OFF with the transmit cycle, then no duty cycle correction is required for that emission.

**Limit**

The radio emission outside the operating frequency band shall be at least 20 dB below that in the 100 kHz bandwidth within the band that contains the highest level of the desired power. Radiated emissions which fall in the restricted bands, as defined in section 15.205, must comply with the radiated emission limits specified in section 15.209.

Frequency MHz	Field Strength uV/m	Field Strength dBµV/m	Detector
30-88	100	40	QP
88-216	150	43.5	QP
216-960	200	46	QP
960-1000	500	54	QP
Above 1000	500	54	AV
Above 1000	5000	74	PK

**Spurious radiated emissions for transmitter**

According to C63.10, if the peak (or quasi-peak) measured value complies with the average limit, it is unnecessary to perform an average measurement, so AV emission value did not show in below table if the peak value complies with average limit.

The only worse case (802.11B mode) test result is listed in the report. If the margin value exceeds 20dBuV/m that not show in the table.

**Transmitting spurious emission test result as below:**

30MHz-1GHz:

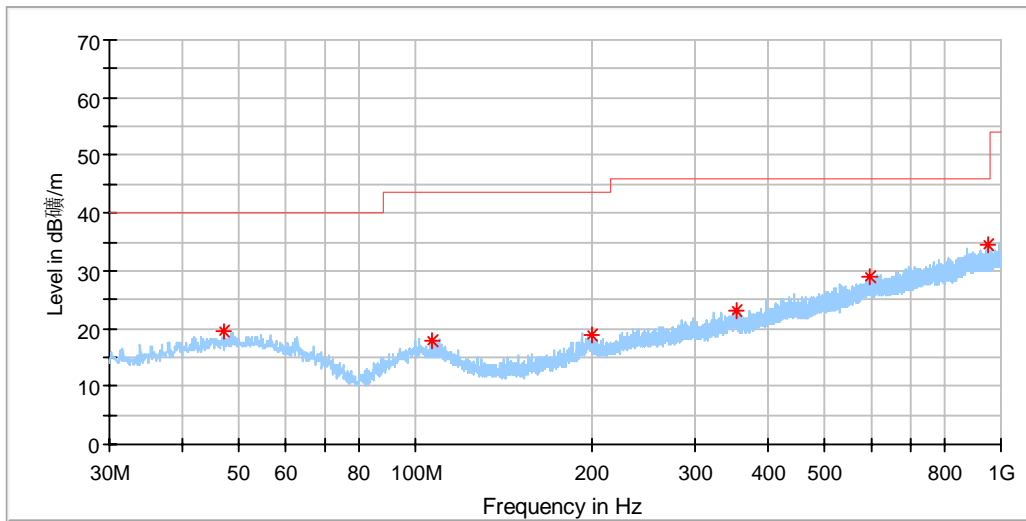

Frequency (MHz)	MaxPeak (dBµV/m)	Limit (dBµV/m)	Margin (dB)	Height (cm)	Pol	Azimuth (deg)	Corr. (dB/m)
47.035625	19.50	40.00	20.50	200.0	H	331.0	20.80
106.690625	17.99	43.50	25.51	200.0	H	0.0	19.12
199.386250	18.78	43.50	24.72	200.0	H	0.0	19.46
354.161875	23.11	46.00	22.89	200.0	H	281.0	23.65
596.480000	29.07	46.00	16.93	100.0	H	79.0	28.51
952.651875	34.57	46.00	11.43	100.0	H	0.0	32.67

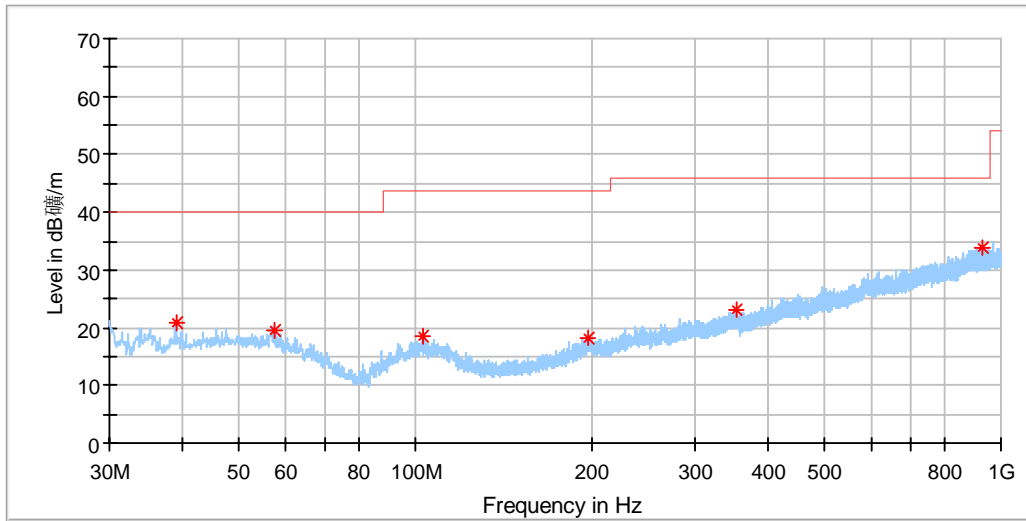

Frequency (MHz)	MaxPeak (dBµV/m)	Limit (dBµV/m)	Margin (dB)	Height (cm)	Pol	Azimuth (deg)	Corr. (dB/m)
39.033125	20.85	40.00	19.15	100.0	V	302.0	19.14
57.523750	19.51	40.00	20.49	100.0	V	0.0	20.38
102.568125	18.49	43.50	25.01	200.0	V	99.0	19.38
197.628125	18.37	43.50	25.13	200.0	V	181.0	19.56
353.070625	23.02	46.00	22.98	100.0	V	268.0	23.62
929.796250	33.78	46.00	12.22	200.0	V	6.0	32.58

11B: 2412MHz  
 1GHz-18GHz:

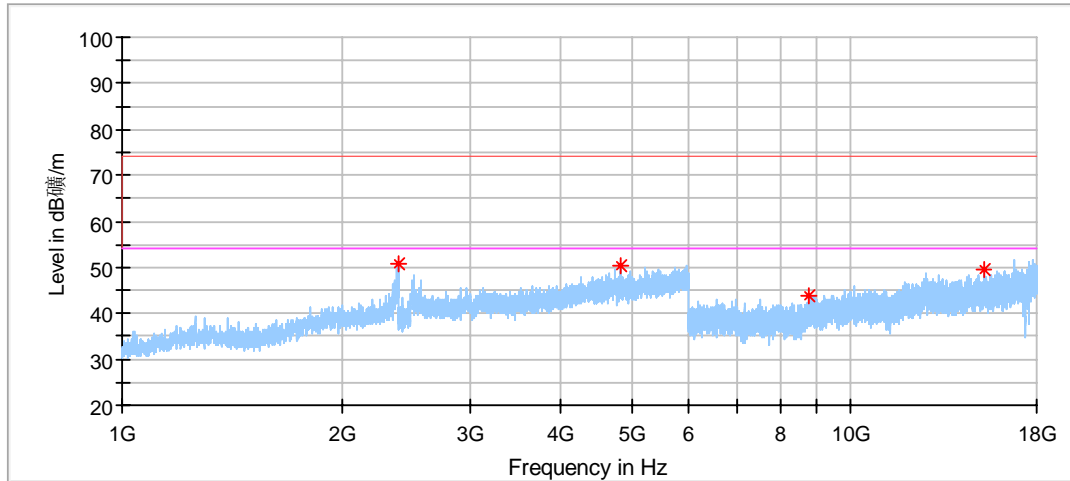

Frequency (MHz)	MaxPeak (dBµV/m)	Limit (dBµV/m)	Margin (dB)	Height (cm)	Pol	Azimuth (deg)	Corr. (dB/m)
2395.000000	50.86	74.00	23.14	150.0	H	219.0	-2.20
4824.500000	50.47	74.00	23.53	150.0	H	343.0	4.41
8785.500000	43.80	74.00	30.20	150.0	H	356.0	11.56
15270.500000	49.72	74.00	24.28	150.0	H	105.0	19.02

Note:

Above 1GHz: Corrector factor = Antenna Factor + Cable Loss- Pre-amplifier

Below 1GHz: Corrector factor = Antenna Factor + Cable Loss

Emission Level =Reading level +Correction Factor

(The Reading Level is recorded by software which is not shown in the sheet)

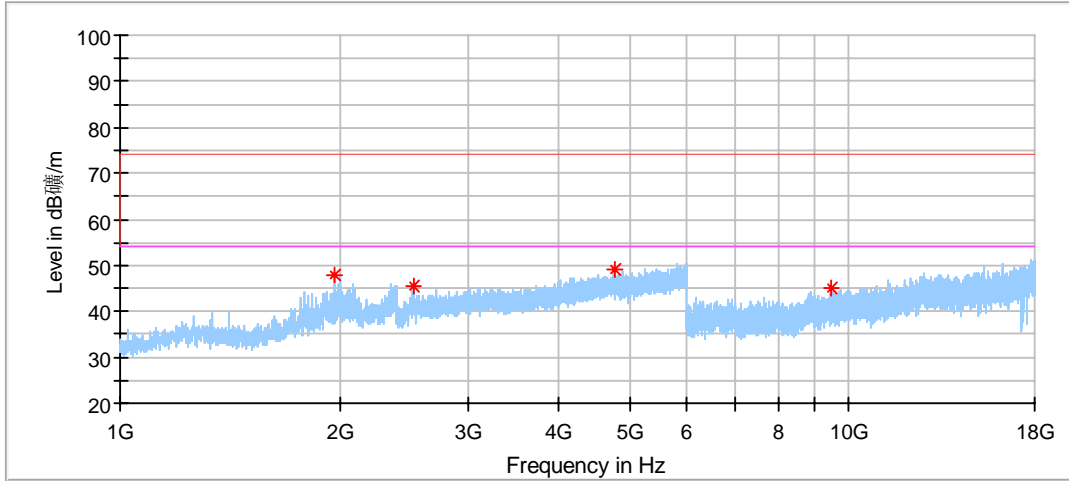

Frequency (MHz)	MaxPeak (dBµV/m)	Limit (dBµV/m)	Margin (dB)	Height (cm)	Pol	Azimuth (deg)	Corr. (dB/m)
1969.000000	48.06	74.00	25.94	150.0	V	178.0	-3.88
2521.500000	45.46	74.00	28.54	150.0	V	276.0	-1.75
4789.500000	49.29	74.00	24.71	150.0	V	97.0	4.36
9450.500000	44.88	74.00	29.12	150.0	V	216.0	12.76

Note:

Above 1GHz: Corrector factor = Antenna Factor + Cable Loss- Pre-amplifier

Below 1GHz: Corrector factor = Antenna Factor + Cable Loss

Emission Level =Reading level +Correction Factor

(The Reading Level is recorded by software which is not shown in the sheet)



11B: 2442MHz

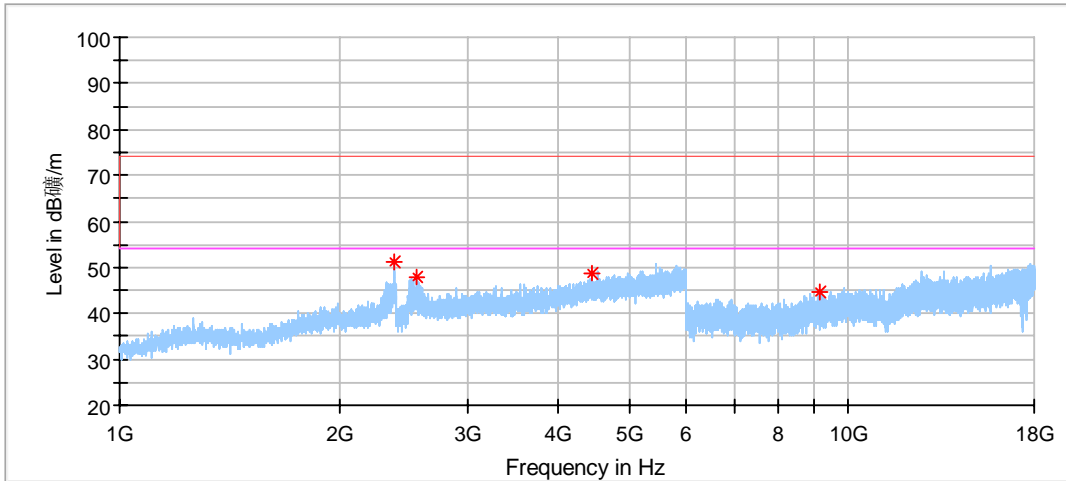

Frequency (MHz)	MaxPeak (dBµV/m)	Limit (dBµV/m)	Margin (dB)	Height (cm)	Pol	Azimuth (deg)	Corr. (dB/m)
2380.000000	51.34	74.00	22.66	150.0	H	59.0	-2.27
2564.500000	48.05	74.00	25.95	150.0	H	219.0	-1.55
4460.000000	48.90	74.00	25.10	150.0	H	228.0	3.51
9161.000000	44.55	74.00	29.45	150.0	H	269.0	11.30

Note:

Above 1GHz: Corrector factor = Antenna Factor + Cable Loss- Pre-amplifier

Below 1GHz: Corrector factor = Antenna Factor + Cable Loss

Emission Level =Reading level +Correction Factor

(The Reading Level is recorded by software which is not shown in the sheet)

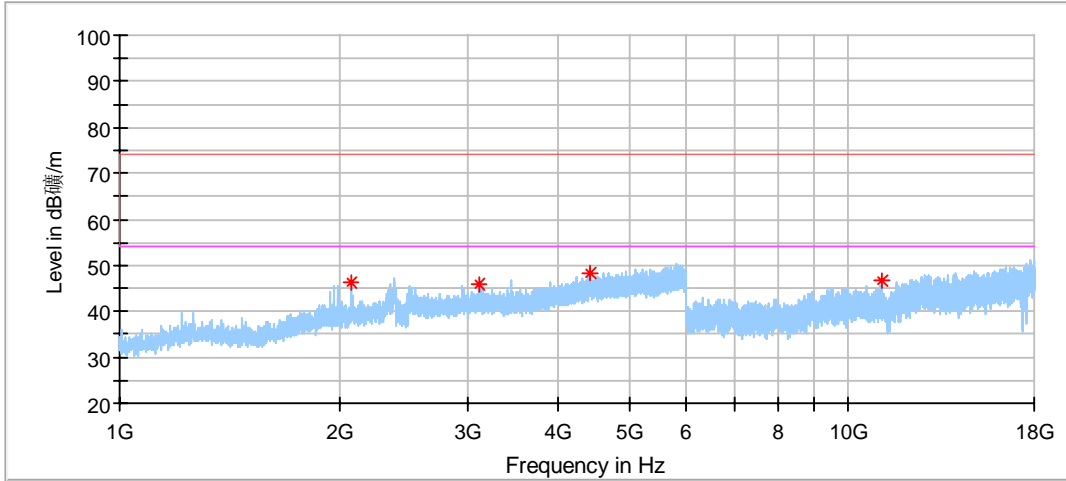

Frequency (MHz)	MaxPeak (dBµV/m)	Limit (dBµV/m)	Margin (dB)	Height (cm)	Pol	Azimuth (deg)	Corr. (dB/m)
2073.500000	46.10	74.00	27.90	150.0	V	183.0	-3.65
3108.500000	45.72	74.00	28.28	150.0	V	94.0	0.16
4418.500000	48.35	74.00	25.65	150.0	V	338.0	3.43
11104.500000	46.53	74.00	27.47	150.0	V	27.0	13.34

Note:

Above 1GHz: Corrector factor = Antenna Factor + Cable Loss- Pre-amplifier

Below 1GHz: Corrector factor = Antenna Factor + Cable Loss

Emission Level =Reading level +Correction Factor

(The Reading Level is recorded by software which is not shown in the sheet)

11B: 2472MHz

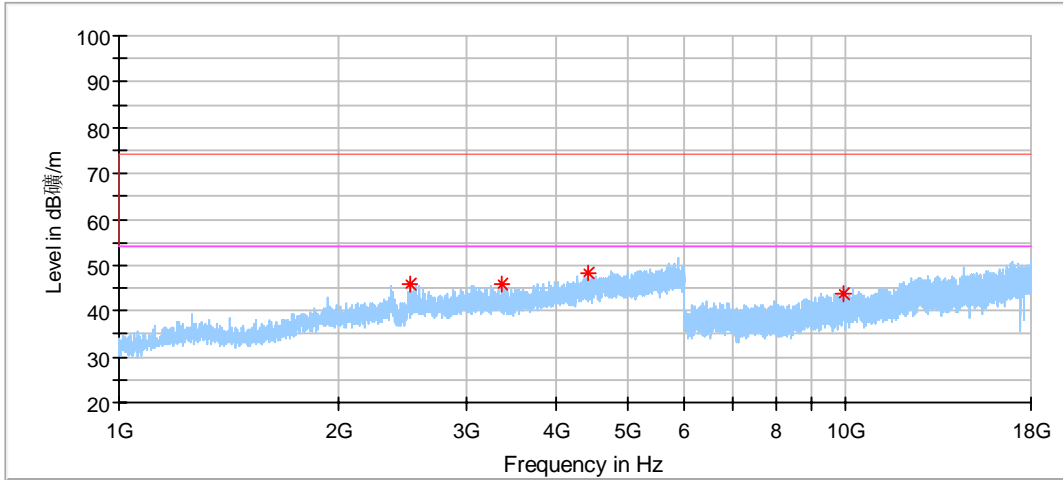

Frequency (MHz)	MaxPeak (dBµV/m)	Limit (dBµV/m)	Margin (dB)	Height (cm)	Pol	Azimuth (deg)	Corr. (dB/m)
2512.500000	45.99	74.00	28.01	150.0	H	321.0	-1.78
3374.000000	45.98	74.00	28.02	150.0	H	294.0	-0.16
4431.500000	48.15	74.00	25.85	150.0	H	85.0	3.44
9955.000000	43.93	74.00	30.07	150.0	H	106.0	12.27

Note:

Above 1GHz: Corrector factor = Antenna Factor + Cable Loss- Pre-amplifier

Below 1GHz: Corrector factor = Antenna Factor + Cable Loss

Emission Level =Reading level +Correction Factor

(The Reading Level is recorded by software which is not shown in the sheet)

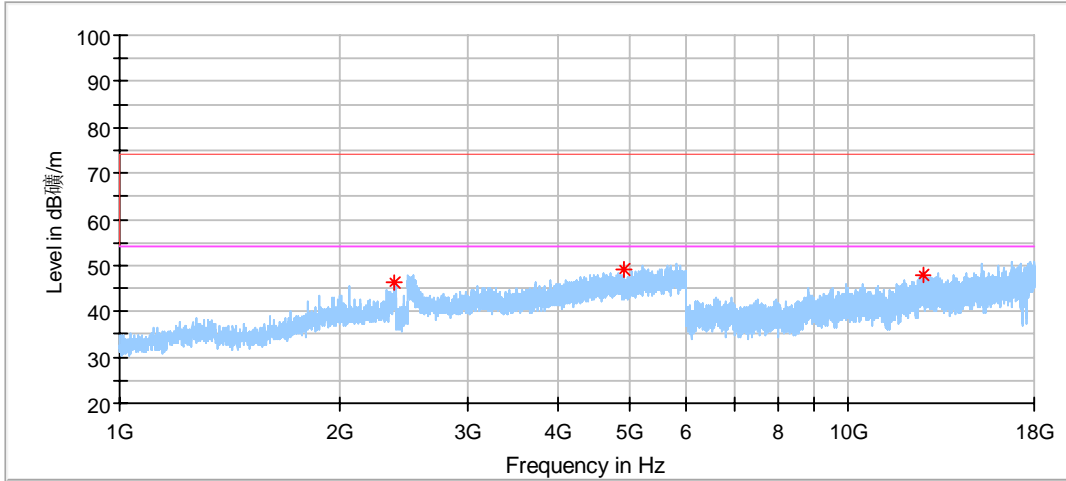

Frequency (MHz)	MaxPeak (dBµV/m)	Limit (dBµV/m)	Margin (dB)	Height (cm)	Pol	Azimuth (deg)	Corr. (dB/m)
2383.500000	46.05	74.00	27.95	150.0	V	175.0	-2.25
4924.500000	49.24	74.00	24.76	150.0	V	4.0	4.55
12635.500000	47.81	74.00	26.19	150.0	V	49.0	16.65

Note:

Above 1GHz: Corrector factor = Antenna Factor + Cable Loss- Pre-amplifier

Below 1GHz: Corrector factor = Antenna Factor + Cable Loss

Emission Level =Reading level +Correction Factor

(The Reading Level is recorded by software which is not shown in the sheet)

Remark:

- (1) Data of measurement within frequency range 18-26GHz are the noise floor or attenuated more than 20dB below the permissible limits or the field strength is too small to be measured, so test data does not present in this report.
- (2) Level=Reading Level + Correction Factor  
 Above 1GHz: Corrector factor = Antenna Factor + Cable Loss- Amplifier Gain  
 Below 1GHz: Corrector factor = Antenna Factor + Cable Loss  
 (The Reading Level is recorded by software which is not shown in the sheet)

## 9 Test Equipment List

### Radiated spurious emission:

Description	Manufacturer	Model no.	Equipment ID	Serial no.	cal interval (year)	cal. due date
EMI Test Receiver	Rohde & Schwarz	ESR 26	68-4-74-14-002	101269	1	2022-6-4
Trilog Super Broadband Test Antenna	Schwarzbeck	VULB 9162	68-4-80-19-003	284	1	2022-2-2
Wave Guide Antenna	ETS	3117	68-4-80-19-001	00218954	1	2022-5-24
Pre-amplifier	Rohde & Schwarz	SCU 18F	68-4-29-19-001	100745	1	2022-10-10
Pre-amplifier	Rohde & Schwarz	SCU 08F2	68-4-29-19-004	08400018	1	2022-10-10
Sideband Horn Antenna	Q-PAR	QWH-SL-18-40-K-SG	68-4-80-14-008	12827	1	2022-7-21
Pre-amplifier	Rohde & Schwarz	SCU 40A	68-4-29-14-002	100432	1	2022-7-27
Attenuator	Mini-circuits	UNAT-6+	68-4-81-21-002	15542	1	2022-8-23
3m Semi-anechoic chamber	TDK	9X6X6	68-4-90-19-006	----	3	2023-5-28
Test software	Rohde & Schwarz	EMC32	68-4-90-19-006-A01	Version10.35.02	N/A	N/A

### Conducted emission:

Description	Manufacturer	Model no.	Equipment ID	Serial no.	cal interval (year)	cal. due date
EMI Test Receiver	Rohde & Schwarz	ESR 3	68-4-74-14-001	101782	1	2022-6-4
LISN	Rohde & Schwarz	ENV4200	68-4-87-14-001	100249	1	2022-6-5
LISN	Rohde & Schwarz	ENV432	68-4-87-16-001	101318	1	2022-6-5
LISN	Rohde & Schwarz	ENV216	68-4-87-14-002	100326	1	2022-6-5
ISN	Rohde & Schwarz	ENY81	68-4-87-14-003	100177	1	2022-6-5
ISN	Rohde & Schwarz	ENY81-CA6	68-4-87-14-004	101664	1	2022-6-5
High Voltage Probe	Schwarzbeck	TK9420(VT9420)	68-4-27-14-001	9420-584	1	2022-6-5
RF Current Probe	Rohde & Schwarz	EZ-17	68-4-27-14-002	100816	1	2022-6-5
Attenuator	Shanghai Huaxiang	TS2-26-3	68-4-81-16-003	080928189	1	2022-6-3
Test software	Rohde & Schwarz	EMC32	68-4-90-14-003-A10	Version9.15.00	N/A	N/A
Shielding Room	TDK	CSR #1	68-4-90-19-004	----	3	2022-11-07

### Conducted RF test:

Description	Manufacturer	Model no.	Equipment ID	Serial no.	cal interval (year)	cal. due date
Signal Analyzer	Rohde & Schwarz	FSV40	68-4-74-14-004	101030	1	2022-6-3



## 10 System Measurement Uncertainty

For a 95% confidence level, the measurement expanded uncertainties for defined systems, in accordance with the recommendations of ISO 17025 were:

### System Measurement Uncertainty

System Measurement Uncertainty	
Test Items	Extended Uncertainty
Uncertainty for Radiated Spurious Emission 30MHz-3000MHz	Horizontal: 4.70dB; Vertical: 4.67dB;
Uncertainty for Radiated Spurious Emission 3000MHz-18000MHz	Horizontal: 4.65dB; Vertical: 4.63dB;
Uncertainty for Radiated Spurious Emission 18000MHz-40000MHz	Horizontal: 4.51dB; Vertical: 4.50dB;
Uncertainty for Conducted Emission in shielding room (68-4-90-19-004) 9kHz-150KHz	3.62dB
Uncertainty for Conducted RF test	RF Power Conducted: 1.31dB Frequency test involved: 0.6x10 <sup>-7</sup> or 1%