



## FCC - TEST REPORT

Report Number : **68.950.21.0154.01** Date of Issue: **2021-03-15**

Model : **MWB-S-WB01**

Product Type : Bluetooth & 2.4GHz Wi-Fi dual band Communication Module

Applicant : GD Midea Air-Conditioning Equipment Co., Ltd.

Address : Lingang Road, Beijiao, Shunde 528311 Foshan, Guangdong  
 PEOPLE'S REPUBLIC OF CHINA

Manufacturer : GD Midea Air-Conditioning Equipment Co., Ltd.

Address : Lingang Road, Beijiao, Shunde 528311 Foshan, Guangdong  
 PEOPLE'S REPUBLIC OF CHINA

Test Result :  **Positive**     **Negative**

Total pages including Appendices : **50**

*TÜV SÜD Certification and Testing (China) Co., Ltd. Shenzhen Branch is a subcontractor to TÜV SÜD Product Service GmbH according to the principles outlined in ISO 17025.*

*TÜV SÜD Certification and Testing (China) Co., Ltd. Shenzhen Branch reports apply only to the specific samples tested under stated test conditions. Construction of the actual test samples has been documented. It is the manufacturer's responsibility to assure that additional production units of this model are manufactured with identical electrical and mechanical components. The manufacturer/importer is responsible to the Competent Authorities in Europe for any modifications made to the production units which result in non-compliance to the relevant regulations. TÜV SÜD Certification and Testing (China) Co., Ltd. Shenzhen Branch shall have no liability for any deductions, inferences or generalizations drawn by the client or others from TÜV SÜD Certification and Testing (China) Co., Ltd. Shenzhen Branch issued reports.*

*This report is the confidential property of the client. As a mutual protection to our clients, the public and ourselves, extracts from the test report shall not be reproduced except in full without our written approval*



# 1 Table of Contents

1	Table of Contents .....	2
2	Details about the Test Laboratory .....	3
3	Description of the Equipment Under Test .....	4
4	Summary of Test Standards .....	5
5	Summary of Test Results .....	6
6	General Remarks .....	7
7	Test Setups .....	8
8	Systems test configuration .....	9
9	Technical Requirement .....	10
9.1	Conducted Emission .....	10
9.2	Conducted peak output power .....	13
9.3	Power spectral density .....	14
9.4	6 dB Bandwidth and 99% Occupied Bandwidth.....	17
9.5	Spurious RF conducted emissions.....	22
9.6	Band edge .....	30
9.7	Spurious radiated emissions for transmitter.....	33
10	Test Equipment List.....	49
11	System Measurement Uncertainty .....	50

## 2 Details about the Test Laboratory

### Details about the Test Laboratory

#### Test Site 1

Company name: TÜV SÜD Certification and Testing (China) Co., Ltd. Shenzhen Branch  
Building 12 & 13, Zhiheng Wisdomland Business Park, Nantou Checkpoint  
Road 2, Nanshan District  
Shenzhen 518052  
P.R. China

Telephone: 86 755 8828 6998

Fax: 86 755 8828 5299

FCC Registration No.: 514049

FCC Designation Number: CA5009

IC Registration No.: 10320A

### 3 Description of the Equipment Under Test

Product:	Bluetooth & 2.4GHz Wi-Fi dual band Communication Module
Model no.:	MWB-S-WB01
FCC ID:	2ADQOMWB-SWB01
Options and accessories:	N/A
Rating:	5Vdc, 100mA, 0.5W
RF Transmission Frequency:	2402MHz-2480MHz
No. of Operated Channel:	40
Modulation:	GFSK
Antenna Type:	Integrated antenna
Antenna Gain:	2.0dBi
Description of the EUT:	The Equipment Under Test (EUT) is a Bluetooth & 2.4GHz Wi-Fi dual band Communication Module which support Bluetooth function and Wi-Fi operated and 2.4GHz.

## 4 Summary of Test Standards

Test Standards	
FCC Part 15 Subpart C 10-1-2020 Edition	PART 15 - RADIO FREQUENCY DEVICES Subpart C - Intentional Radiators

All the test methods were according to KDB 558074 D01 15.247 Meas Guidance v05r02 and ANSI C63.10 (2013).

## 5 Summary of Test Results

Technical Requirements						
FCC Part 15 Subpart C						
Test Condition	Pages	Test Site	Test Result			
			Pass	Fail	N/A	
§15.207	Conducted emission AC power port	10	Site 1	<input checked="" type="checkbox"/>	<input type="checkbox"/>	<input checked="" type="checkbox"/>
§15.247 (b) (1)	Conducted peak output power	13	Site 1	<input checked="" type="checkbox"/>	<input type="checkbox"/>	<input type="checkbox"/>
§15.247(a)(1)	20dB bandwidth	---	---	<input type="checkbox"/>	<input type="checkbox"/>	<input checked="" type="checkbox"/>
§15.247(a)(1)	Carrier frequency separation	---	---	<input type="checkbox"/>	<input type="checkbox"/>	<input checked="" type="checkbox"/>
§15.247(a)(1)(iii)	Number of hopping frequencies	---	---	<input type="checkbox"/>	<input type="checkbox"/>	<input checked="" type="checkbox"/>
§15.247(a)(1)(iii)	Dwell Time	---	---	<input type="checkbox"/>	<input type="checkbox"/>	<input checked="" type="checkbox"/>
§15.247(a)(2)	6dB bandwidth and 99% Occupied Bandwidth	17	Site 1	<input checked="" type="checkbox"/>	<input type="checkbox"/>	<input type="checkbox"/>
§15.247(e)	Power spectral density	14	Site 1	<input checked="" type="checkbox"/>	<input type="checkbox"/>	<input type="checkbox"/>
§15.247(d)	Spurious RF conducted emissions	22	Site 1	<input checked="" type="checkbox"/>	<input type="checkbox"/>	<input type="checkbox"/>
§15.247(d)	Band edge	30	Site 1	<input checked="" type="checkbox"/>	<input type="checkbox"/>	<input type="checkbox"/>
§15.247(d)	Spurious radiated emissions for transmitter	33	Site 1	<input checked="" type="checkbox"/>	<input type="checkbox"/>	<input type="checkbox"/>
§15.203	Antenna requirement	See note 2		<input checked="" type="checkbox"/>	<input type="checkbox"/>	<input type="checkbox"/>

Note 1: N/A=Not Applicable.

Note 2: The EUT uses an Integrated antenna, which gain is 2.0dBi. In accordance to §15.203, it is considered sufficiently to comply with the provisions of this section.

## 6 General Remarks

### Remarks

This submittal(s) (test report) is intended for FCC ID: 2ADQOMWB-SWB01 complies with Section 15.207, 15.209, 15.247 of the FCC Part 15, Subpart C rules.

This report is for Bluetooth Low Energy only.

### SUMMARY:

All tests according to the regulations cited on page 5 were.

- Performed

- **Not** Performed

The Equipment under Test

- **Fulfills** the general approval requirements.

- **Does not** fulfill the general approval requirements.

Sample Received Date: 2021-02-01

Testing Start Date: 2021-02-01

Testing End Date: 2021-03-10

- TÜV SÜD Certification and Testing (China) Co., Ltd. Shenzhen Branch -

Reviewed by:



John Zhi  
Project Manager

Prepared by:



Warlen Song  
Project Engineer

Tested by:



Louise Liu  
Test Engineer

## 7 Test Setups

### 7.1 AC Power Line Conducted Emission test setups

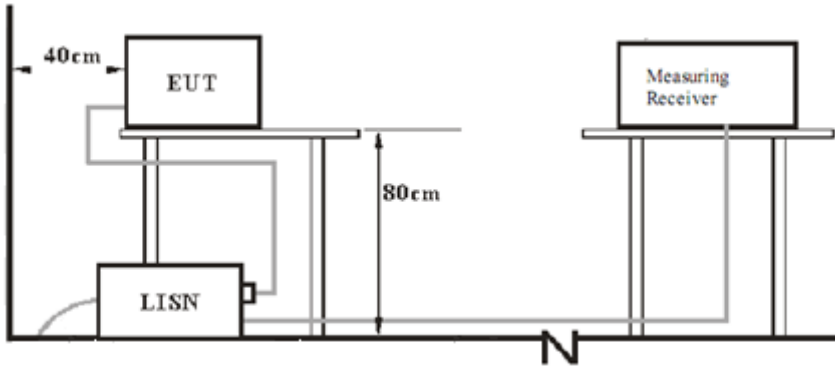

### 7.2 Radiated test setups Below 1GHz

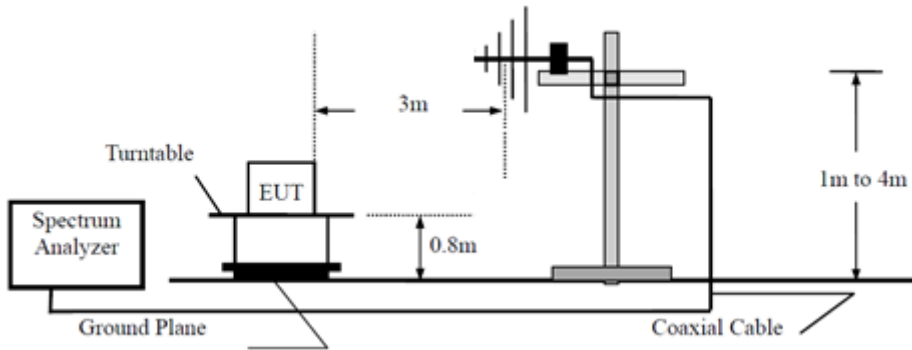

### Above 1GHz

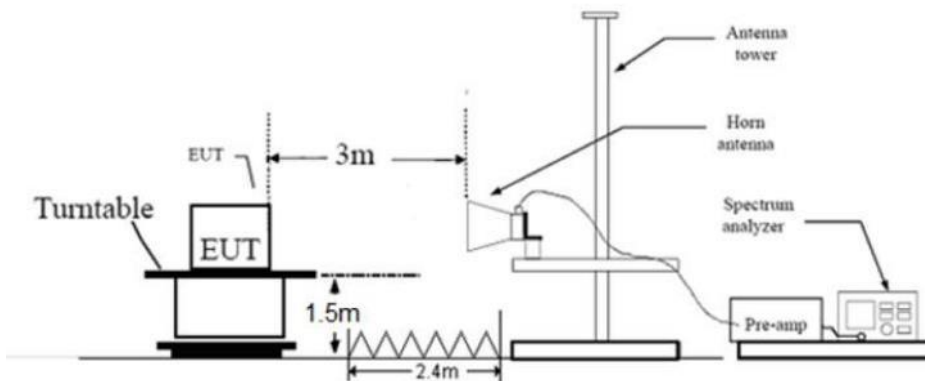

### 7.3 Conducted RF test setups

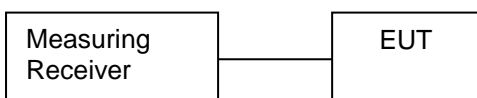



## 8 Systems test configuration

Auxiliary Equipment Used during Test:

DESCRIPTION	MANUFACTURER	MODEL NO.	S/N
Notebook	Lenovo	X240	---
Adapter	Apple	A1443	---

## 9 Technical Requirement

### 9.1 Conducted Emission

#### Test Method

1. The EUT was placed on a table, which is 0.8m above ground plane
2. The power line of the EUT is connected to the AC mains through a Artificial Mains Network (A.M.N.).
3. Maximum procedure was performed to ensure EUT compliance
4. A EMI test receiver is used to test the emissions from both sides of AC line

#### Limit

According to §15.207, conducted emissions limit as below:

Frequency MHz	QP Limit dB $\mu$ V	AV Limit dB $\mu$ V
0.150-0.500	66-56*	56-46*
0.500-5	56	46
5-30	60	50

Remark: “\*” Decreasing linearly with logarithm of the frequency

## Conducted Emission

Product Type : Bluetooth & 2.4GHz Wi-Fi dual band Communication Module  
 M/N : MWB-S-WB01  
 Operating Condition : Transmit  
 Test Specification : Power Line, Live  
 Comment : AC 120V/60Hz

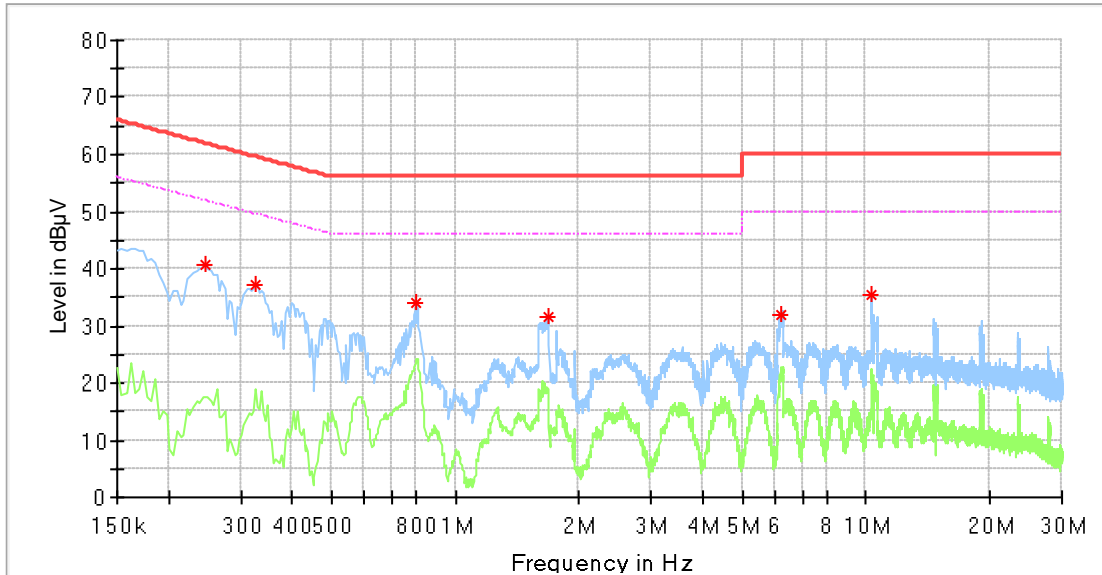

Frequency (MHz)	MaxPeak (dBµV)	Average (dBµV)	Limit (dBµV)	Margin (dB)	Line	Corr. (dB)
0.246000	40.61	---	61.89	21.28	L1	10.32
0.326000	37.23	---	59.55	22.32	L1	10.32
0.806000	34.13	---	56.00	21.87	L1	10.34
1.682000	31.61	---	56.00	24.39	L1	10.36
6.202000	31.99	---	60.00	28.01	L1	10.58
10.334000	35.40	---	60.00	24.60	L1	10.76

Remark :

Level=Reading Level + Correction Factor

Correction Factor=Cable Loss + LISN Factor

(The Reading Level is recorded by software which is not shown in the sheet)

## Conducted Emission

Product Type : Bluetooth & 2.4GHz Wi-Fi dual band Communication Module  
 M/N : MWB-S-WB01  
 Operating Condition : Transmit  
 Test Specification : Power Line, Neutral  
 Comment : AC 120V/60Hz

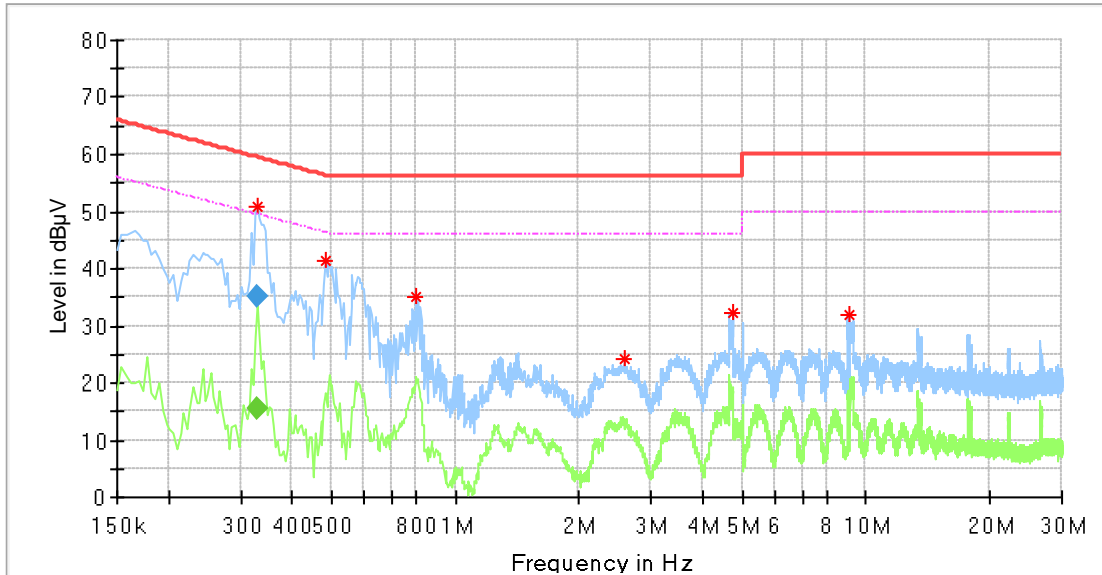

Frequency (MHz)	MaxPeak (dBµV)	Average (dBµV)	Limit (dBµV)	Margin (dB)	Line	Corr. (dB)
0.329500	50.75	---	59.45	8.70	N	10.33
0.482000	41.49	---	56.30	14.82	N	10.33
0.798000	35.04	---	56.00	20.96	N	10.35
2.578000	24.27	---	56.00	31.73	N	10.43
4.722000	32.26	---	56.00	23.74	N	10.53
9.070000	31.76	---	60.00	28.24	N	10.77
Frequency	QuasiPea	Average	Limit	Margin	Line	Corr.
0.329500	---	15.40	49.46	34.06	N	10.33
0.329500	35.09	---	59.46	24.37	N	10.33

Remark :

Level=Reading Level + Correction Factor

Correction Factor=Cable Loss + LISN Factor

(The Reading Level is recorded by software which is not shown in the sheet)

## 9.2 Conducted peak output power

### Test Method

1. The RF output of EUT was connected to the power meter by RF cable. The path loss was compensated to the results for each measurement.
2. Set to the maximum power setting and enable the EUT transmit continuously
3. Use the following test receiver settings:  
Span = approximately 5 times the 6dB bandwidth, centered on a hopping channel  
RBW > the 6dB bandwidth of the emission being measured, VBW $\geq$ 3RBW,  
Sweep = auto, Detector function = peak, Trace = max hold
4. Allow the trace to stabilize. Use the marker-to-peak function to set the marker to the peak of the emission. The indicated level is the peak output power and record the results in the test report.
5. Repeat above procedures until all frequencies measured were complete.

### Limits

According to §15.247 (b) (1), conducted peak output power limit as below:

Frequency Range MHz	Limit W	Limit dBm
2400-2483.5	$\leq 1$	$\leq 30$

Test result as below table

Frequency MHz	Data Rate bps	Conducted Peak Output Power dBm	Result
Bottom channel 2402MHz	LE 1M	5.04	Pass
Middle channel 2440MHz	LE 1M	5.04	Pass
Top channel 2480MHz	LE 1M	4.76	Pass
Bottom channel 2402MHz	LE 2M	6.67	Pass
Middle channel 2440MHz	LE 2M	6.45	Pass
Top channel 2480MHz	LE 2M	6.16	Pass

### 9.3 Power spectral density

#### Test Method

1. The RF output of EUT was connected to the test receiver by RF cable. The path loss was compensated to the results for each measurement.
2. Set to the maximum power setting and enable the EUT transmit continuously
3. Set analyzer center frequency to DTS channel center frequency. RBW=3kHz, VBW $\geq$ 3RBW, Span=1.5 times DTS bandwidth, Detector=Peak, Sweep=auto, Trace= max hold.
4. Allow the trace to stabilize. Use the marker-to-peak function to set the marker to the peak of the emission. The indicated level is the peak output power and record the results in the test report.
5. Repeat above procedures until other frequencies measured were completed.

#### Limit

Limit [dBm/3KHz]

≤8

#### Test result

Frequency MHz	Data Rate bps	Power spectral density dBm/3KHz	Result
Bottom channel 2402MHz	LE 1M	-13.57	Pass
Middle channel 2440MHz	LE 1M	-13.18	Pass
Top channel 2480MHz	LE 1M	-13.72	Pass
Bottom channel 2402MHz	LE 2M	-9.82	Pass
Middle channel 2440MHz	LE 2M	-8.59	Pass
Top channel 2480MHz	LE 2M	-10.36	Pass

BLE\_1M\_2402

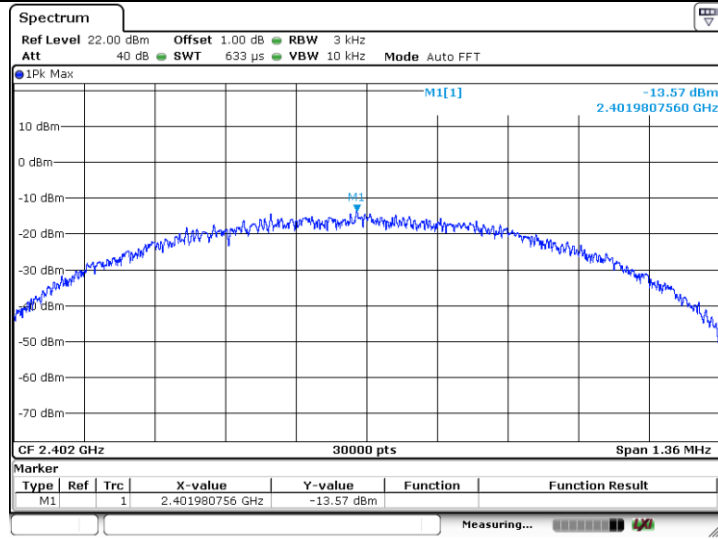

Date: 10.MAR.2021 14:16:26

BLE\_1M\_2440

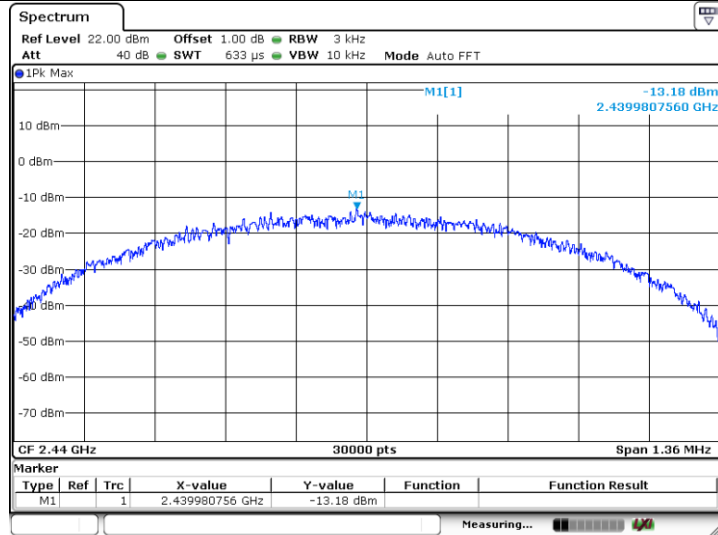

Date: 10.MAR.2021 14:16:58

BLE\_1M\_2480

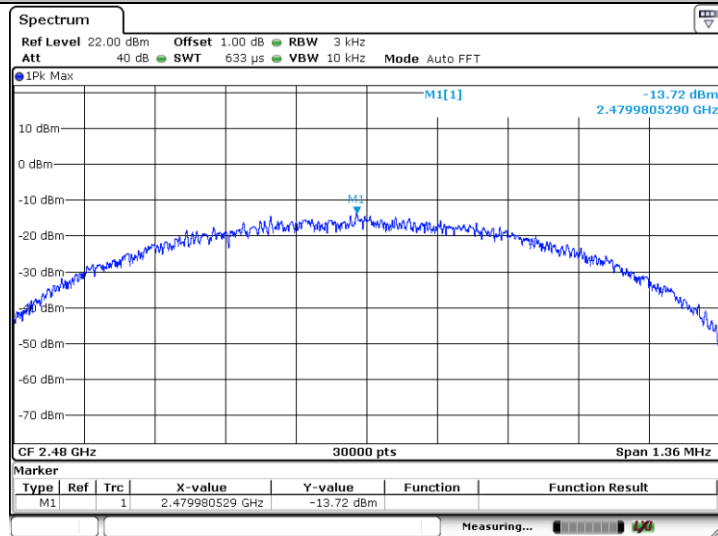

Date: 10.MAR.2021 14:17:22

### BLE\_2M\_2402

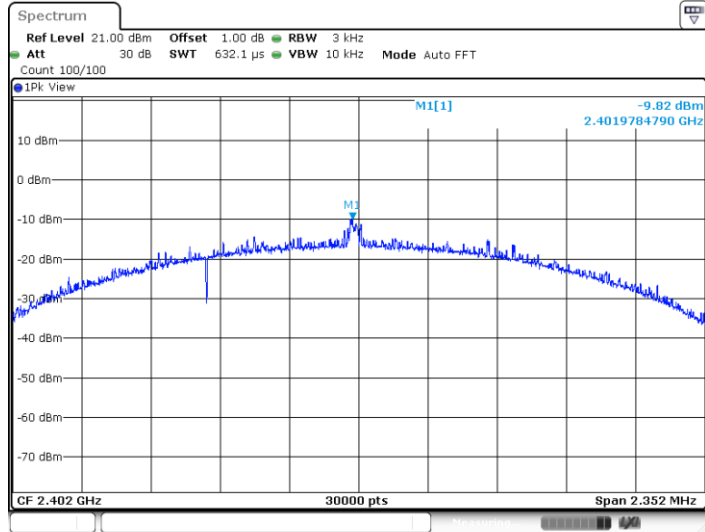

Date: 25.FEB.2021 02:23:45

### BLE\_2M\_2440

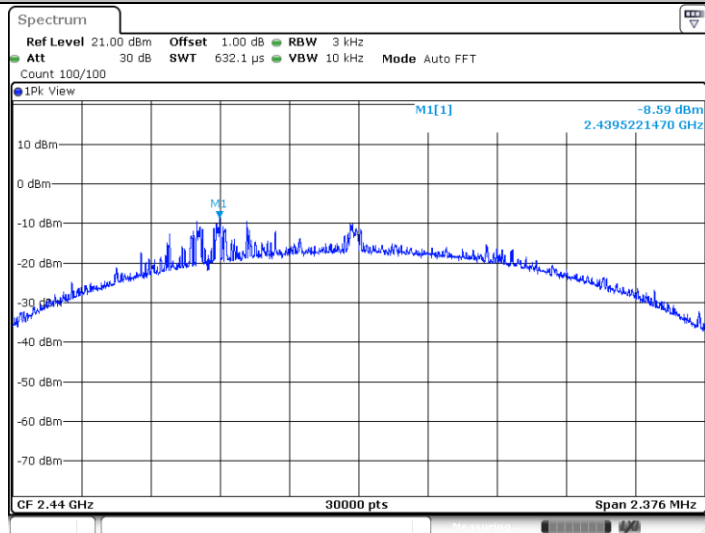

Date: 25.FEB.2021 02:27:13

### BLE\_2M\_2480

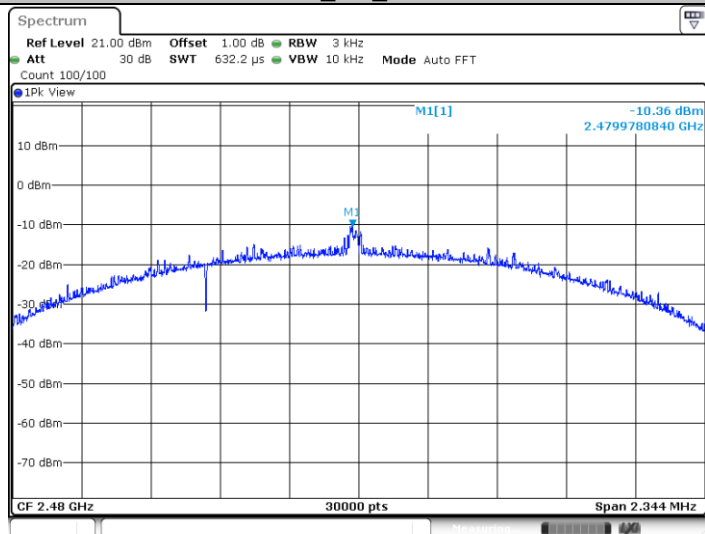

Date: 25.FEB.2021 02:29:20



## 9.4 6 dB Bandwidth and 99% Occupied Bandwidth

### Test Method

1. The RF output of EUT was connected to the test receiver by RF cable. The path loss was compensated to the results for each measurement.
2. Set to the maximum power setting and enable the EUT transmit continuously.
3. Use the following test receiver settings:  
Span = approximately 5 times the 6dB bandwidth, centered on a hopping channel  
RBW =100KHz, VBW $\geq$ 3RBW,  
Sweep = auto, Detector function = peak, Trace = max hold
4. Allow the trace to stabilize. Use the marker-to-peak function to set the marker to the peak of the emission. Measure the frequency difference of two frequencies that were attenuated 6 dB from the reference level. Record the frequency difference as the emission bandwidth. Record the results.
5. Repeat above procedures until all frequencies measured were complete.

### Limit

Limit [kHz]

≥500

### Test result

Frequency MHz	Data Rate bps	6dB bandwidth MHz	99% bandwidth MHz	Result
Bottom channel 2402MHz	LE 1M	0.664	1.019	Pass
Middle channel 2440MHz	LE 1M	0.668	1.019	Pass
Top channel 2480MHz	LE 1M	0.664	1.023	Pass
Bottom channel 2402MHz	LE 2M	1.176	2.01	Pass
Middle channel 2440MHz	LE 2M	1.188	2.01	Pass
Top channel 2480MHz	LE 2M	1.172	2.006	Pass

6 dB Bandwidth

BLE\_1M\_2402

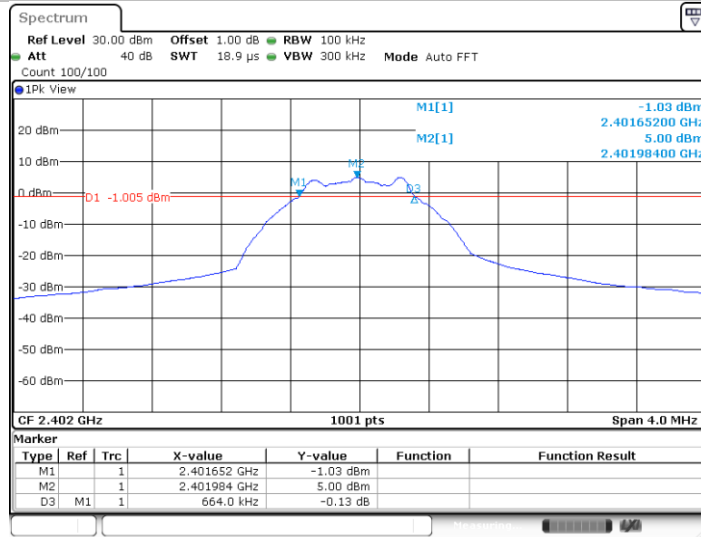

Date: 25.FEB.2021 01:07:18

BLE\_1M\_2440

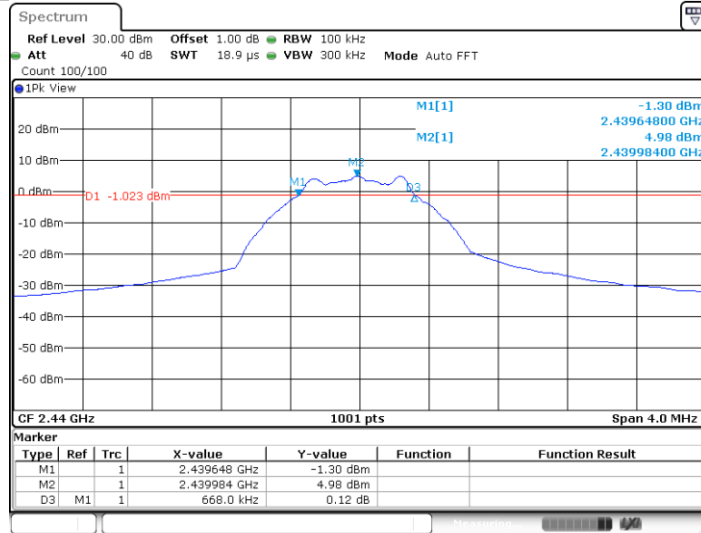

Date: 25.FEB.2021 01:09:10

BLE\_1M\_2480

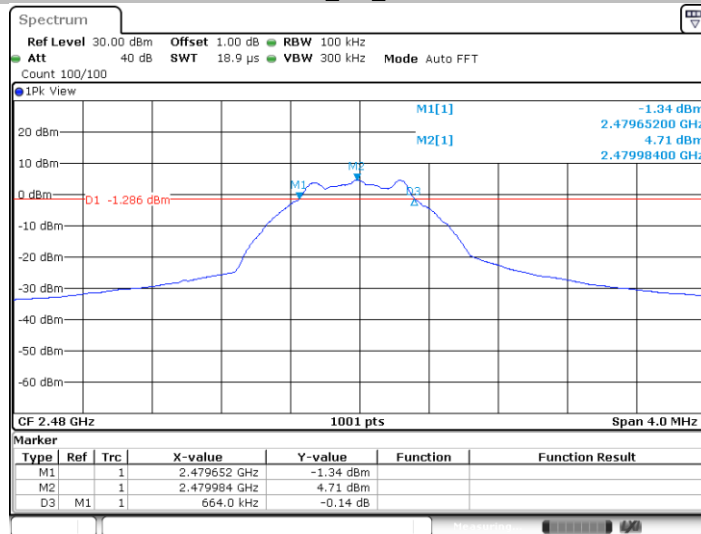

Date: 25.FEB.2021 01:10:48

BLE\_2M\_2402

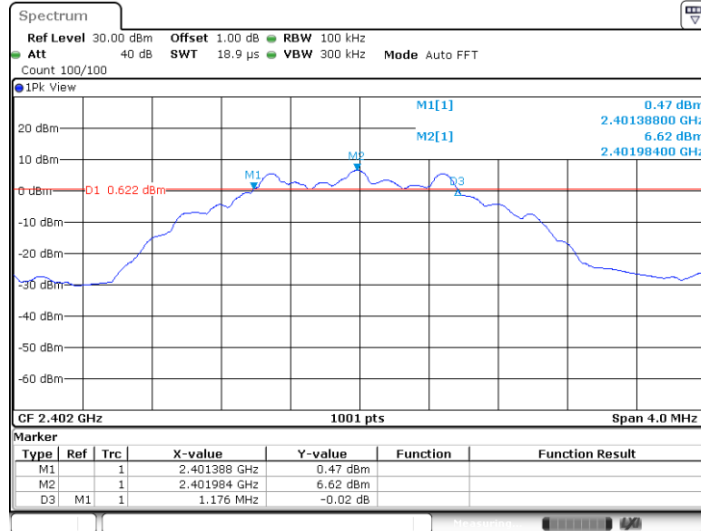

Date: 25.FEB.2021 02:23:22

BLE\_2M\_2440

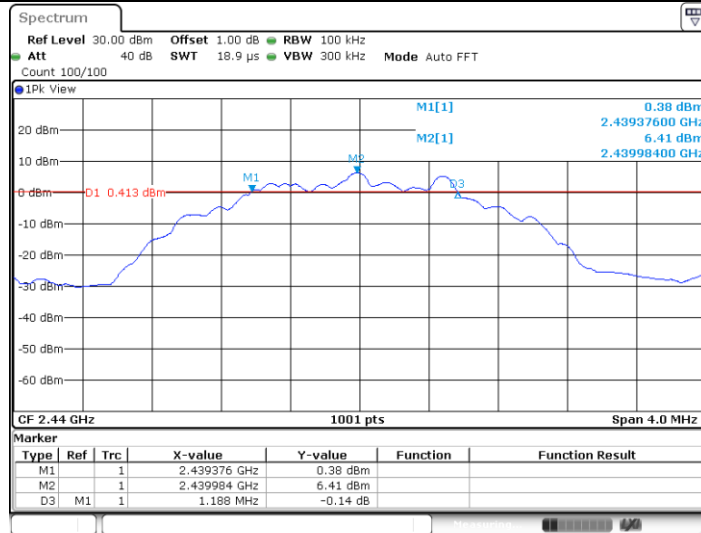

Date: 25.FEB.2021 02:26:50

BLE\_2M\_2480

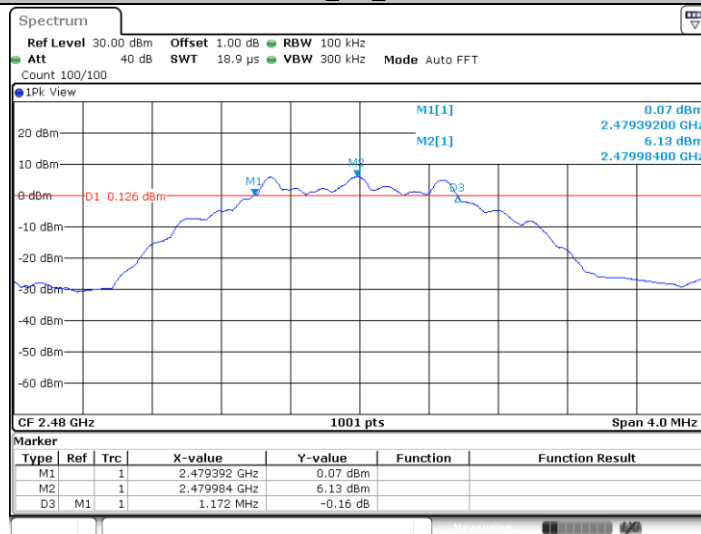

Date: 25.FEB.2021 02:28:57

99% Bandwidth

BLE\_1M\_2402

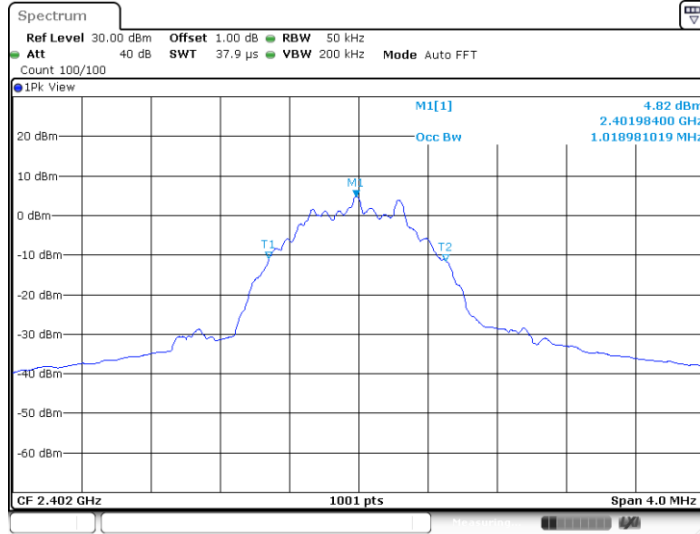

Date: 25.FEB.2021 01:07:29

BLE\_1M\_2440

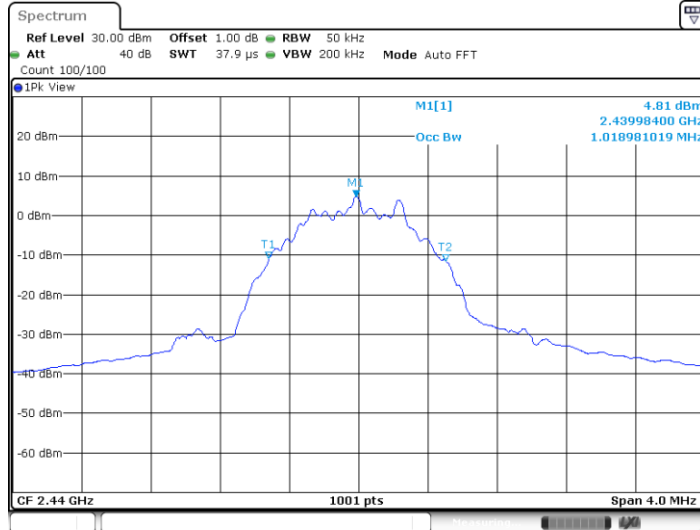

Date: 25.FEB.2021 01:09:21

BLE\_1M\_2480

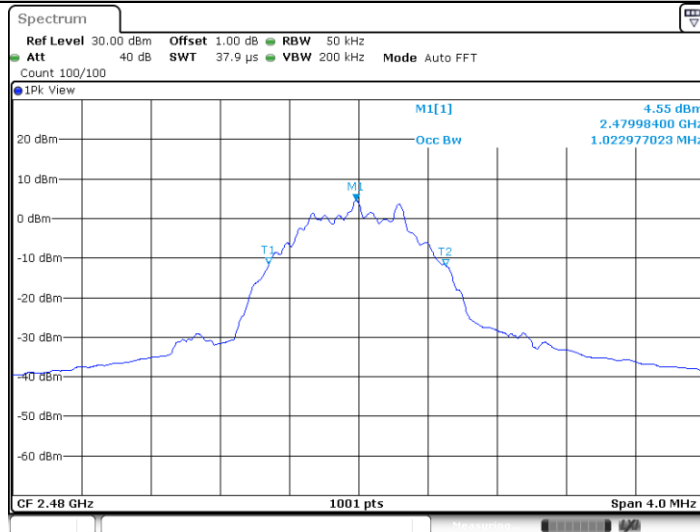

Date: 25.FEB.2021 01:10:59

### BLE\_2M\_2402

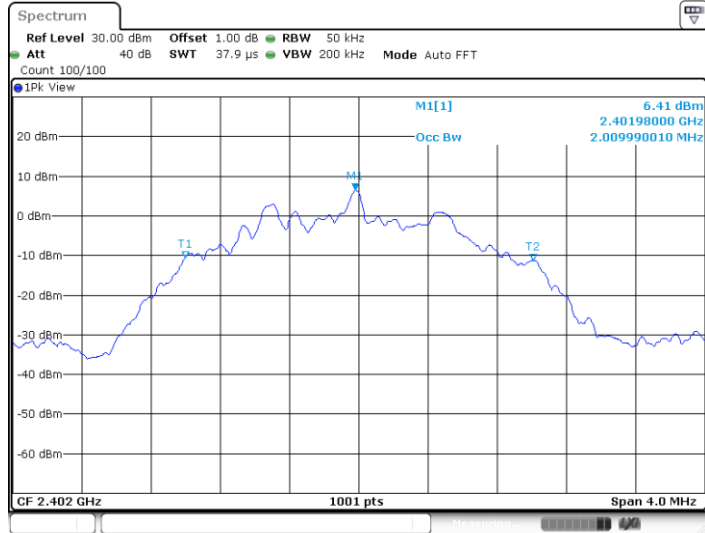

Date: 25.FEB.2021 02:23:33

### BLE\_2M\_2440



Date: 25.FEB.2021 02:27:00

### BLE\_2M\_2480

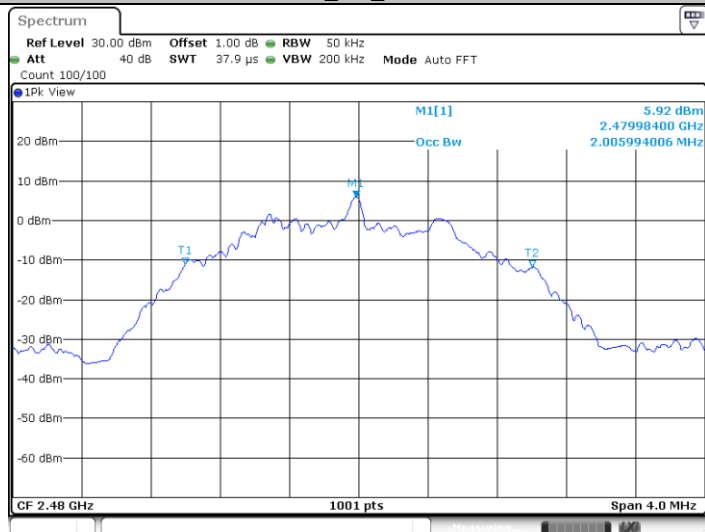

Date: 25.FEB.2021 02:29:08

## 9.5 Spurious RF conducted emissions

### Test Method

1. The RF output of EUT was connected to the spectrum analyzer by RF cable. The path loss was compensated to the results for each measurement.
2. Set to the maximum power setting and enable the EUT transmit continuously.
3. Set RBW = 100 kHz, VBW=300 kHz, Peak Detector. Unwanted Emissions measured in any 100 kHz bandwidth outside of the authorized frequency band shall be attenuated by at least 20 dB relative to the maximum in-band peak PSD level in 100 kHz when maximum peak conducted output power procedure is used. If the transmitter complies with the conducted power limits based on the use of RMS averaging over a time interval, the attenuation required under this paragraph shall be 30 dB instead of 20 dB.
4. Measure and record the results in the test report.
5. The RF fundamental frequency should be excluded against the limit line in the operating frequency

### Limit

Frequency Range MHz	Limit (dBc)
30-25000	-20

### Spurious RF conducted emissions

TestMode	Antenna	Channel (MHz)	FreqRange (MHz)	RefLevel	Result (dBm)	Limit (dBm)	Verdict
BLE_1M	Ant1	2402	Reference	5.06 dBm	5.06	---	PASS
		2402	30~1000	30~1000 MHz	-68.38	<=-14.94	PASS
		2402	1000~26500	1000~26500 MHz	-49.5	<=-14.94	PASS
		2440	Reference	4.95 dBm	4.95	---	PASS
		2440	30~1000	30~1000 MHz	-68.25	<=-15.05	PASS
		2440	1000~26500	1000~26500 MHz	-51.7	<=-15.05	PASS
		2480	Reference	4.74 dBm	4.74	---	PASS
		2480	30~1000	30~1000 MHz	-68.03	<=-15.26	PASS
BLE_2M	Ant1	2402	Reference	6.66 dBm	6.66	---	PASS
		2402	30~1000	30~1000 MHz	-68.36	<=-13.34	PASS
		2402	1000~26500	1000~26500 MHz	-26.91	<=-13.34	PASS
		2440	Reference	6.37 dBm	6.37	---	PASS
		2440	30~1000	30~1000 MHz	-67.76	<=-13.63	PASS
		2440	1000~26500	1000~26500 MHz	-51.78	<=-13.63	PASS
		2480	Reference	6.16 dBm	6.16	---	PASS
		2480	30~1000	30~1000 MHz	-68.01	<=-13.84	PASS
		2480	1000~26500	1000~26500 MHz	-52.79	<=-13.84	PASS

BLE\_1M\_Ant1\_2402\_0~Reference

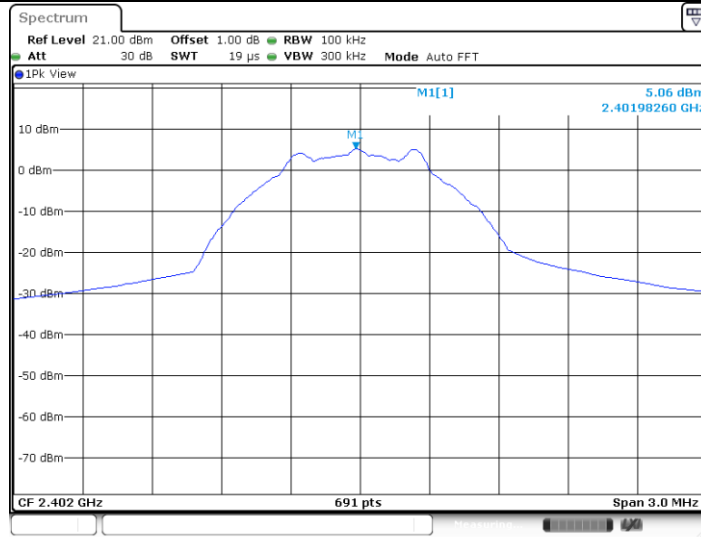

Date: 25.FEB.2021 01:07:58

BLE\_1M\_Ant1\_2402\_30~1000

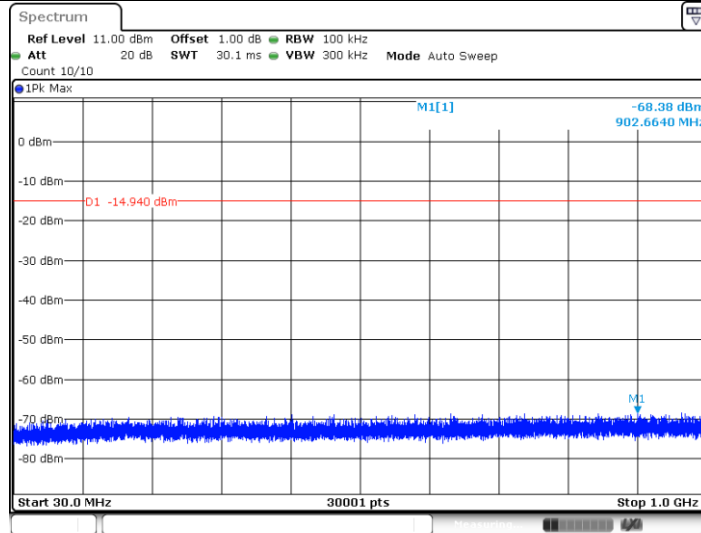

Date: 25.FEB.2021 01:08:04

BLE\_1M\_Ant1\_2402\_1000~26500

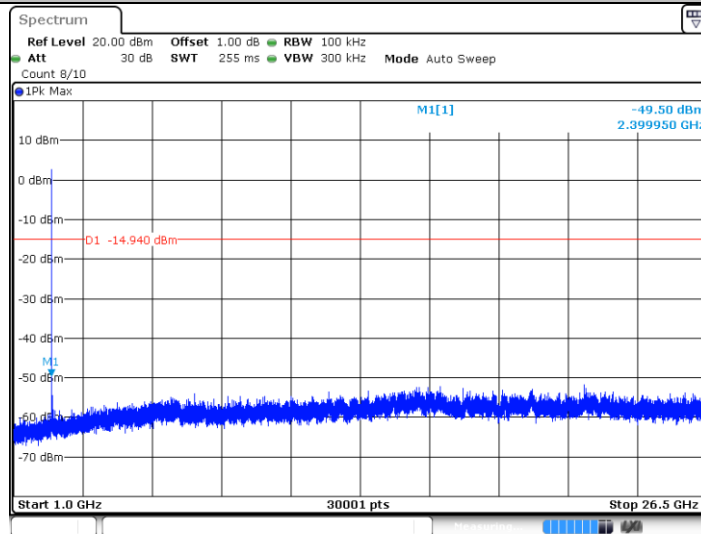

Date: 25.FEB.2021 01:08:12



BLE\_1M\_Ant1\_2440\_0~Reference

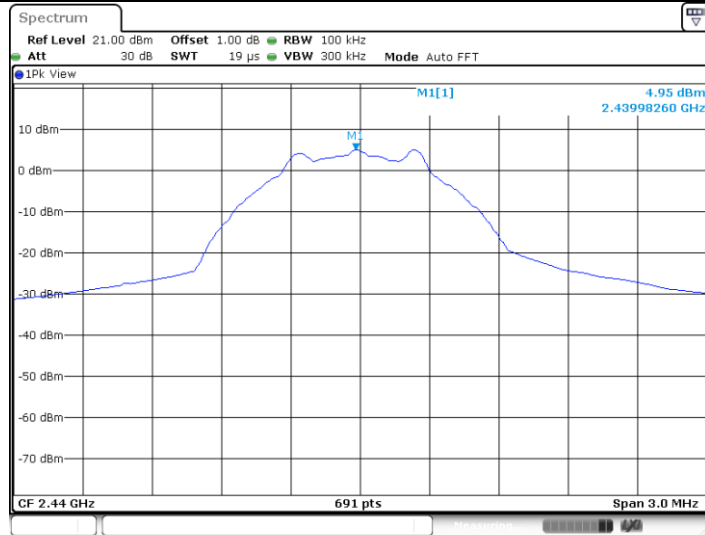

Date: 25.FEB.2021 01:09:39

BLE\_1M\_Ant1\_2440\_30~1000

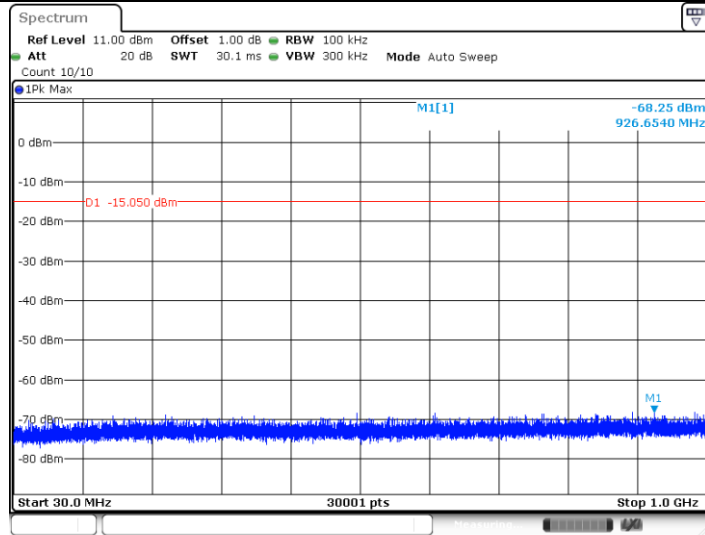

Date: 25.FEB.2021 01:09:46

BLE\_1M\_Ant1\_2440\_1000~26500

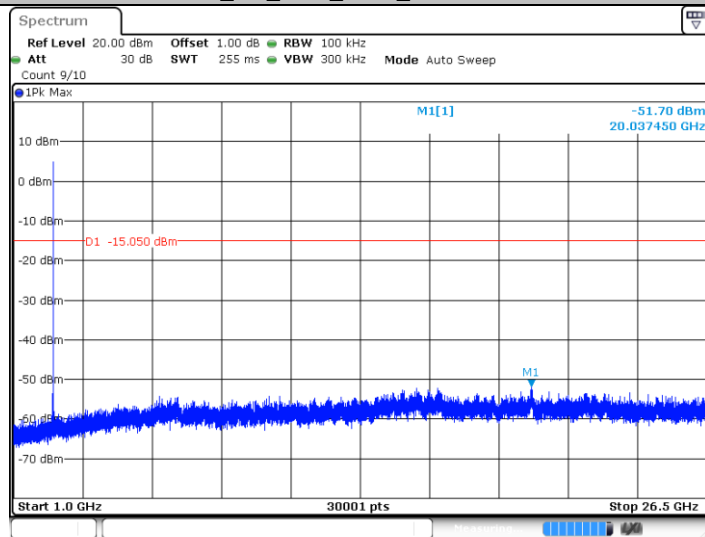

Date: 25.FEB.2021 01:09:53

BLE\_1M\_Ant1\_2480\_0~Reference

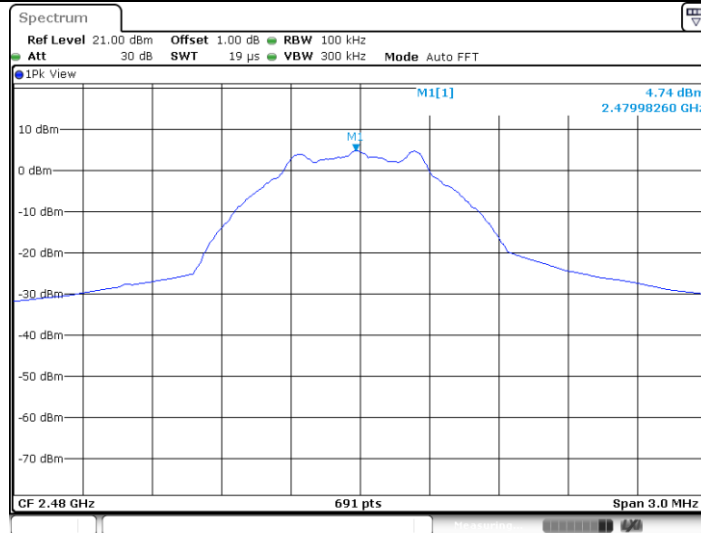

Date: 25.FEB.2021 01:11:26

BLE\_1M\_Ant1\_2480\_30~1000

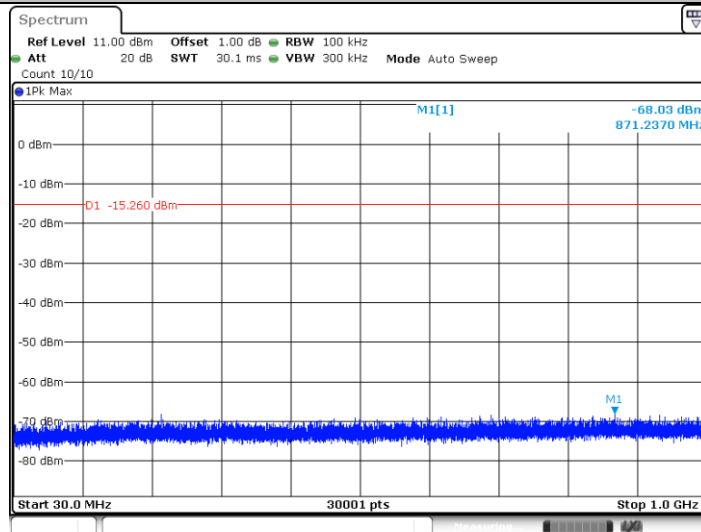

Date: 25.FEB.2021 01:11:32

BLE\_1M\_Ant1\_2480\_1000~26500

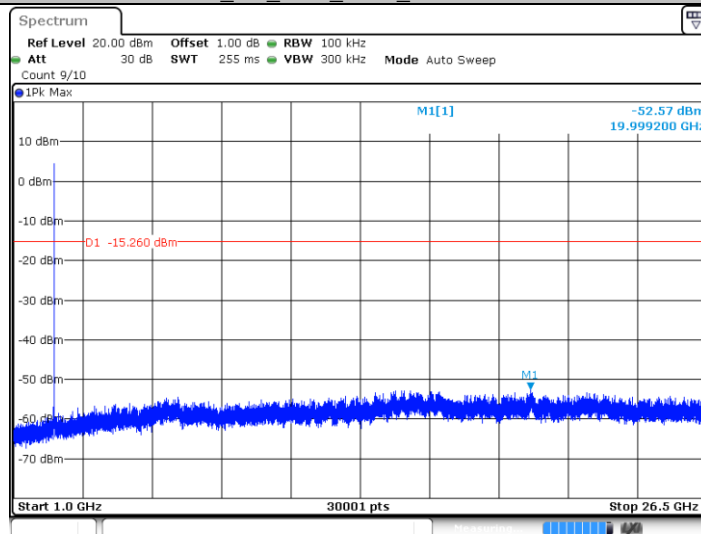

Date: 25.FEB.2021 01:11:39

BLE\_2M\_Ant1\_2402\_0-Reference

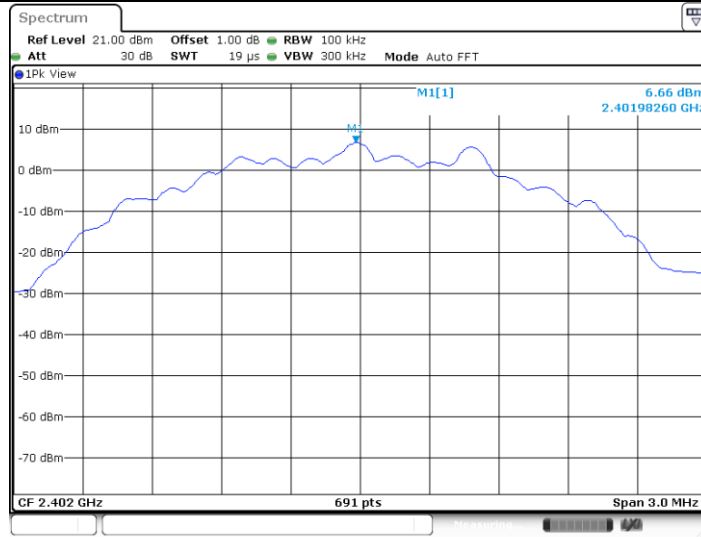

Date: 25.FEB.2021 02:24:55

BLE\_2M\_BT5.0\_Ant1\_2402\_30-1000

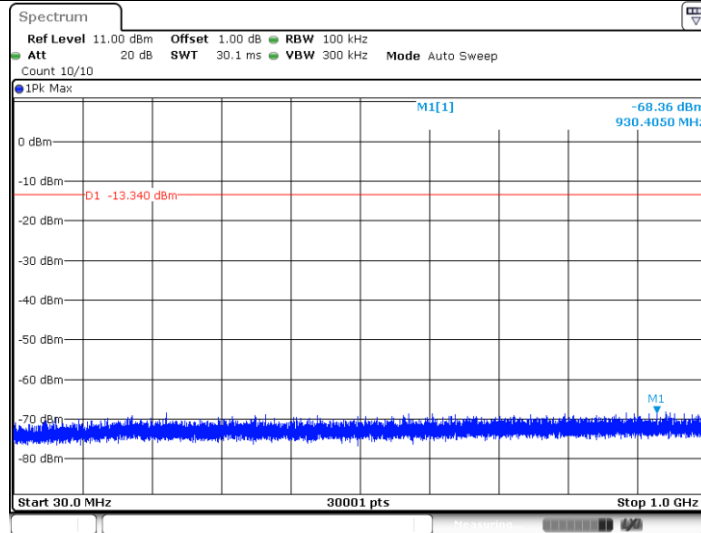

Date: 25.FEB.2021 02:25:01

BLE\_2M\_Ant1\_2402\_1000-26500

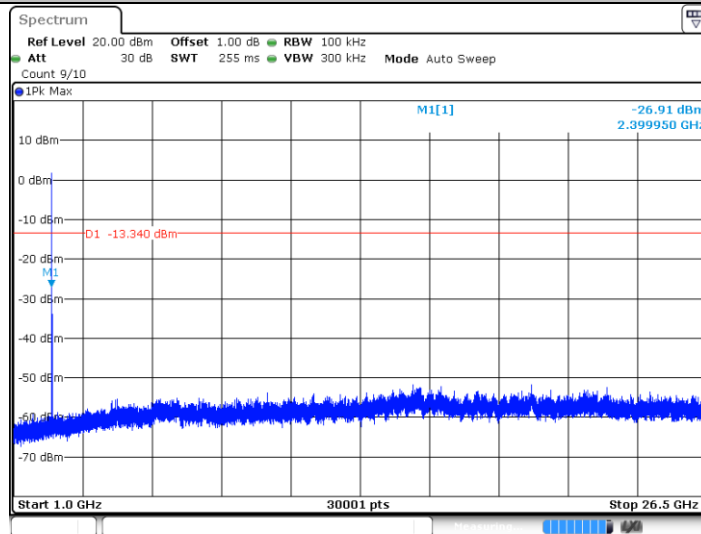

Date: 25.FEB.2021 02:25:09

BLE\_2M\_Ant1\_2440\_0~Reference

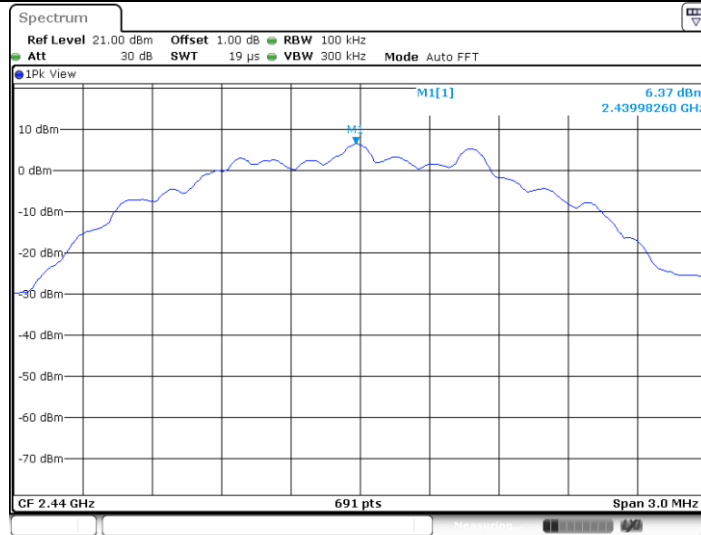

Date: 25.FEB.2021 02:27:18

BLE\_2M\_Ant1\_2440\_30~1000

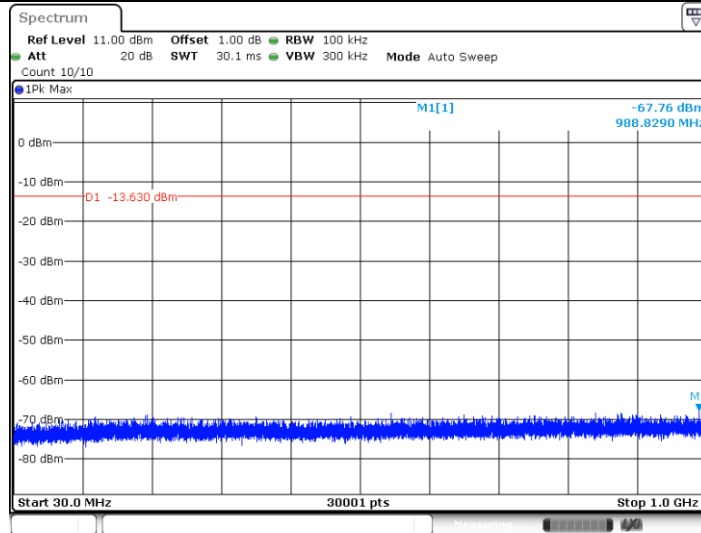

Date: 25.FEB.2021 02:27:24

BLE\_2M\_Ant1\_2440\_1000~26500

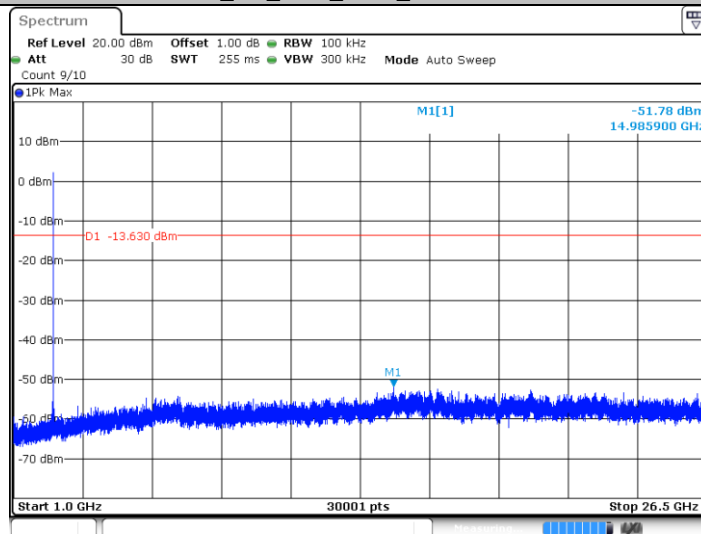

Date: 25.FEB.2021 02:27:32

BLE\_2M\_Ant1\_2480\_0~Reference

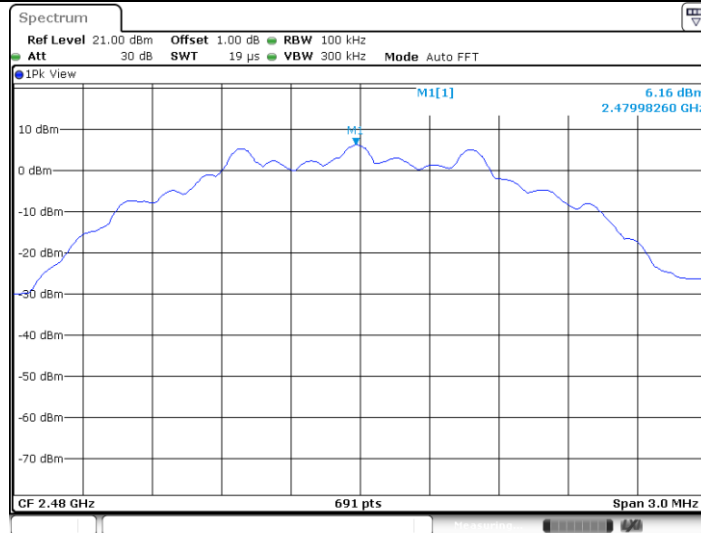

Date: 25.FEB.2021 02:30:28

BLE 2M Ant1 2480\_30~1000

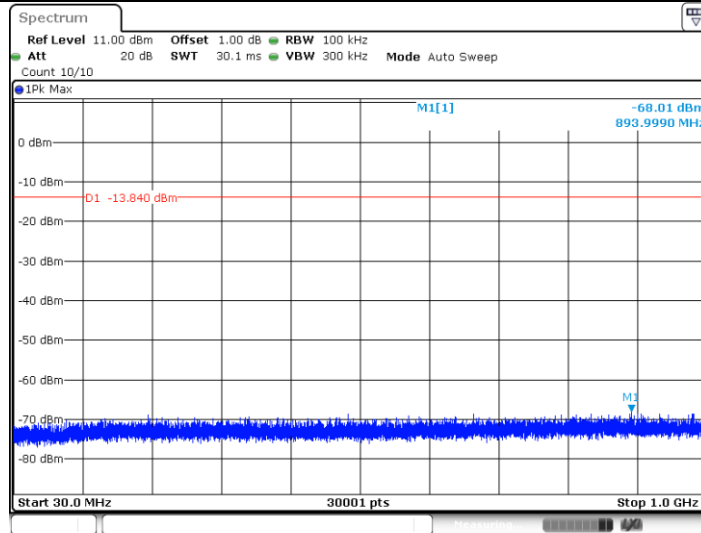

Date: 25.FEB.2021 02:30:34

BLE 2M Ant1 2480\_1000~26500

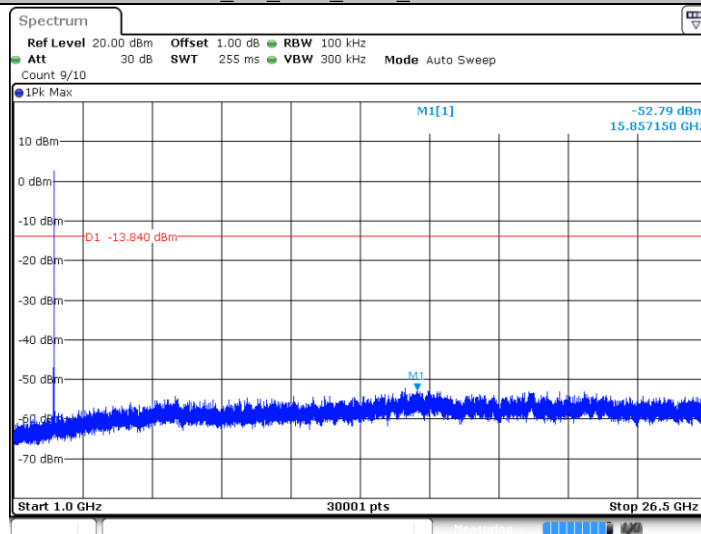

Date: 25.FEB.2021 02:30:42

## 9.6 Band edge

### Test Method

1. The RF output of EUT was connected to the spectrum analyzer by RF cable. The path loss was compensated to the results for each measurement.
2. Set to the maximum power setting and enable the EUT transmit continuously.
3. Set RBW = 100 kHz, VBW=300 kHz, Peak Detector. Unwanted Emissions measured in any 100 kHz bandwidth outside of the authorized frequency band shall be attenuated by at least 20 dB relative to the maximum in-band peak PSD level in 100 kHz when maximum peak conducted output power procedure is used. If the transmitter complies with the conducted power limits based on the use of RMS averaging over a time interval, the attenuation required under this paragraph shall be 30 dB instead of 20 dB.
4. Measure and record the results in the test report.
5. The RF fundamental frequency should be excluded against the limit line in the operating frequency
6. Set to the maximum power setting and enable the EUT hopping mode, repeat the test.

### Limit

Frequency Range MHz	Limit (dBm)
30-25000	-20

### Band edge testing

Test Mode bps	Antenna	ChName	Channel (MHz)	RefLevel (dBm)	Result (dBm)	Limit (dBm)	Verdict
BLE_1M	Ant1	Low	2402	5.07	-37.39	<=-14.93	PASS
		High	2480	4.70	-37.96	<=-15.3	PASS
BLE_2M	Ant1	Low	2402	6.60	-29.56	<=-13.4	PASS
		High	2480	6.10	-36.2	<=-13.9	PASS

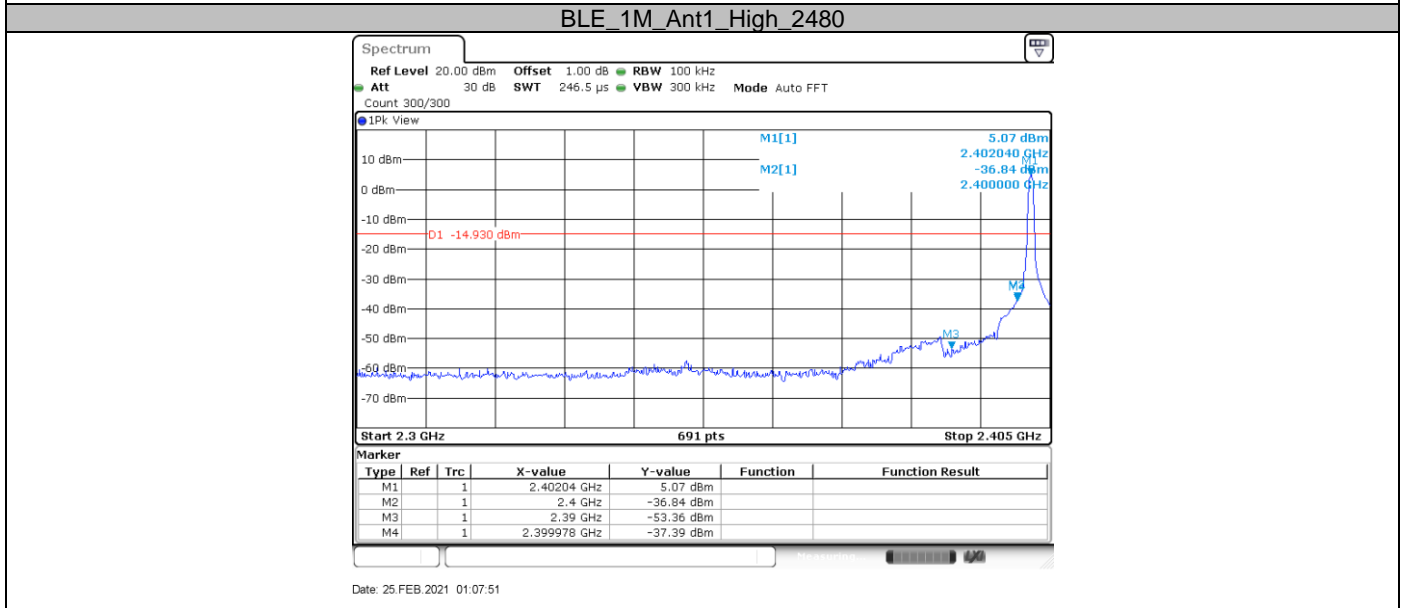
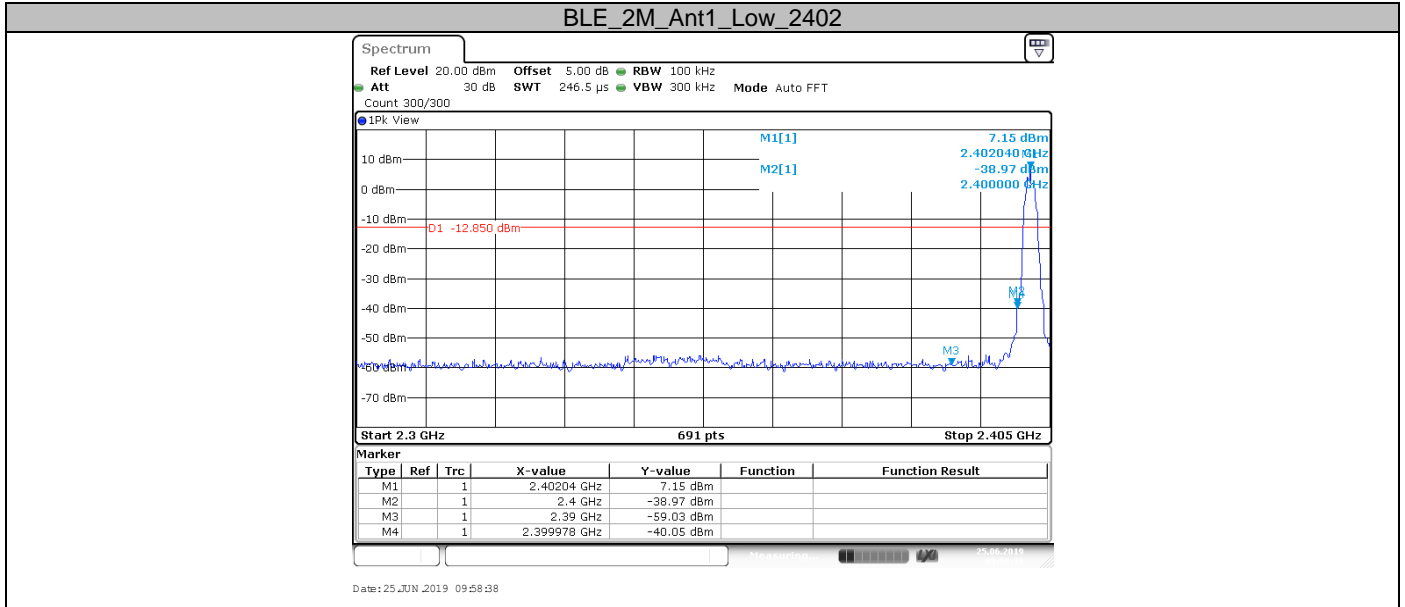

**BLE\_1M\_Ant1\_Low\_2402**

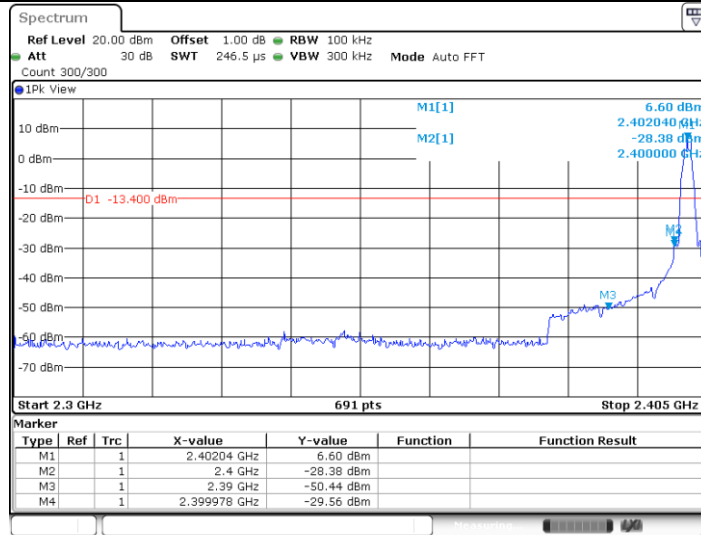

Date: 25.FEB.2021 02:23:54

BLE 2M\_Ant1\_High\_2480

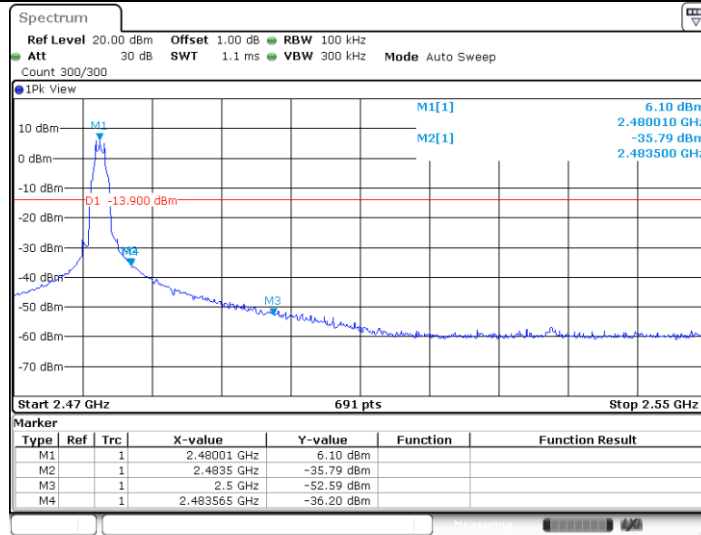

Date: 25.FEB.2021 02:29:29



## 9.7 Spurious radiated emissions for transmitter

### Test Method

- 1: The EUT was placed on a turn table which is 1.5m above ground plane for above 1GHz and 0.8m above ground for below 1GHz at 3 meter chamber room for test. The table was rotated 360 degrees to determine the position of the highest radiation.
- 2: The EUT was set 3 meters away from the interference – receiving antenna, which was mounted on the top of a variable – height antenna tower.
- 3: The height of antenna is varied from one meter to four meters above the ground to determine the maximum value of the field strength. Both horizontal and vertical polarizations of the antenna are set to make the measurement.
- 4: For each suspected emission, the EUT was arranged to its worst case and then the antenna was tuned to heights from 1 meter to 4 meters and the rotatable table was turned from 0 degrees to 360 degrees to find the maximum reading.
- 5: Use the following spectrum analyzer settings According to C63.10:

For Below 1GHz

Use the following spectrum analyzer settings:

Span = wide enough to capture the peak level of the in-band emission and all spurious  
 RBW = 100 KHz to 120KHz, VBW ≥ RBW for peak measurement, Sweep = auto, Detector function = peak, Trace = max hold.

For Peak unwanted emissions Above 1GHz:

Span = wide enough to capture the peak level of the in-band emission and all spurious  
 RBW = 1MHz, VBW ≥ RBW for peak measurement, Sweep = auto, Detector function = peak, Trace = max hold.

Procedures for average unwanted emissions measurements above 1000 MHz

- a) RBW = 1 MHz.
- b)  $VBW \geq [3 \times RBW]$ .
- c) Detector = RMS (power averaging), if  $[\text{span} / (\# \text{ of points in sweep})] \leq RBW / 2$ .  
 Satisfying this condition can require increasing the number of points in the sweep or reducing the span. If the condition is not satisfied, then the detector mode shall be set to peak.
- d) Averaging type = power (i.e., rms) (As an alternative, the detector and averaging type may be set for linear voltage averaging. Some instruments require linear display mode to use linear voltage averaging. Log or dB averaging shall not be used.)
- e) Sweep time = auto.
- f) Perform a trace average of at least 100 traces if the transmission is continuous. If the transmission is not continuous, then the number of traces shall be increased by a factor of  $1 / D$ , where  $D$  is the duty cycle. For example, with 50% duty cycle, at least 200 traces shall be averaged. (If a specific emission is demonstrated to be continuous—i.e., 100% duty cycle—then rather than turning ON and OFF with the transmit cycle, at least 100 traces shall be averaged.)
- g) If tests are performed with the EUT transmitting at a duty cycle less than 98%, then a correction factor shall be added to the measurement results prior to comparing with the emission limit, to compute the emission level that would have been measured had the test been performed at 100% duty cycle. The correction factor is computed as follows:
  - 1) If power averaging (rms) mode was used in the preceding step e), then the correction factor is  $[10 \log (1 / D)]$ , where  $D$  is the duty cycle. For example, if the transmit duty

cycle was 50%, then 3 dB shall be added to the measured emission levels.

2) If linear voltage averaging mode was used in the preceding step e), then the correction factor is  $[20 \log (1 / D)]$ , where D is the duty cycle. For example, if the transmit duty cycle was 50%, then 6 dB shall be added to the measured emission levels.

3) If a specific emission is demonstrated to be continuous (100% duty cycle) rather than turning ON and OFF with the transmit cycle, then no duty cycle correction is required for that emission.

## Limit

The radio emission outside the operating frequency band shall be at least 20 dB below that in the 100 kHz bandwidth within the band that contains the highest level of the desired power. Radiated emissions which fall in the restricted bands, as defined in section 15.205, must comply with the radiated emission limits specified in section 15.209.

Frequency MHz	Field Strength uV/m	Field Strength dB $\mu$ V/m	Detector
30-88	100	40	QP
88-216	150	43.5	QP
216-960	200	46	QP
960-1000	500	54	QP
Above 1000	500	54	AV
Above 1000	5000	74	PK

### Spurious radiated emissions for transmitter

According to C63.10, if the peak (or quasi-peak) measured value complies with the average limit, it is unnecessary to perform an average measurement, so AV emission value did not show in below table if the peak value complies with average limit.

**Transmitting spurious emission test result as below:**  
30MHz-1000MHz:

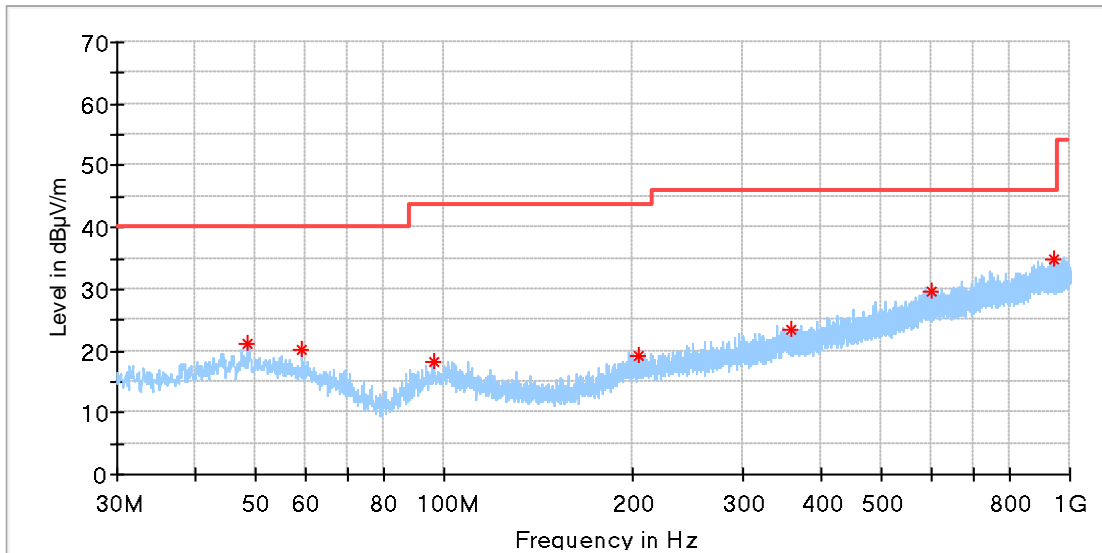

Frequency (MHz)	MaxPeak (dBµV/m)	Limit (dBµV/m)	Margin (dB)	Height (cm)	Pol	Azimuth (deg)	Corr. (dB/m)
48.490625	21.05	40.00	18.95	100.0	H	0.0	17.86
59.281875	20.06	40.00	19.94	200.0	H	327.0	16.96
96.081250	18.20	43.50	25.30	200.0	H	0.0	15.77
204.054375	19.27	43.50	24.23	200.0	H	71.0	16.57
358.526875	23.53	46.00	22.47	200.0	H	227.0	20.59
600.481250	29.63	46.00	16.37	100.0	H	235.0	25.65
944.588750	34.81	46.00	11.19	200.0	H	62.0	29.71

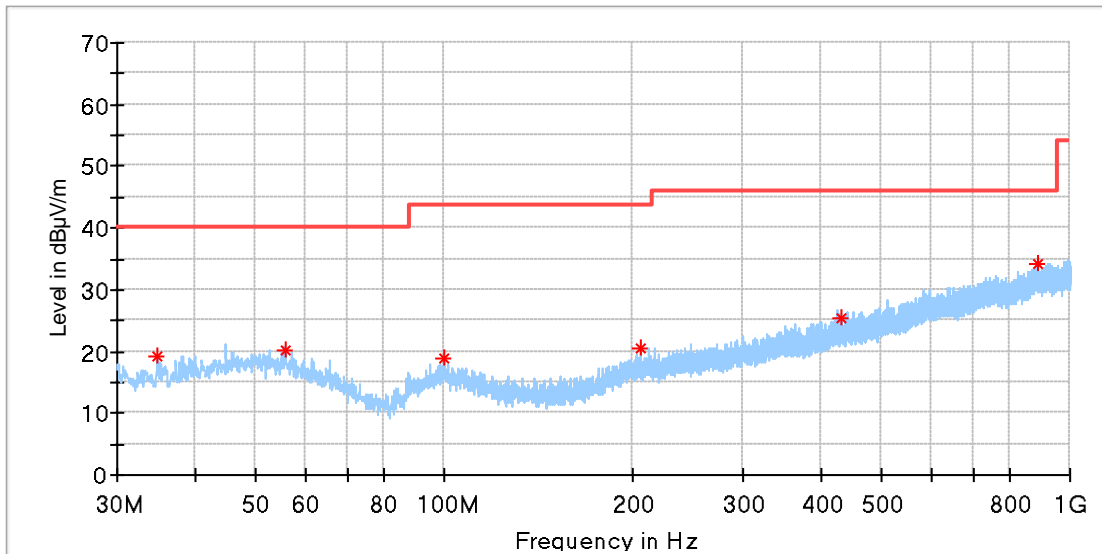

Frequency (MHz)	MaxPeak (dBµV/m)	Limit (dBµV/m)	Margin (dB)	Height (cm)	Pol	Azimuth (deg)	Corr. (dB/m)
34.728750	19.36	40.00	20.64	100.0	V	351.0	14.67
55.826250	20.15	40.00	19.86	200.0	V	116.0	17.47
99.840000	18.83	43.50	24.67	200.0	V	323.0	16.23
206.358125	20.42	43.50	23.08	200.0	V	126.0	16.58
431.883125	25.41	46.00	20.59	200.0	V	303.0	22.05
891.663125	34.23	46.00	11.77	200.0	V	264.0	29.43

1GHz -18GHz:  
BLE\_1M-2402MHz  
Horizontal:

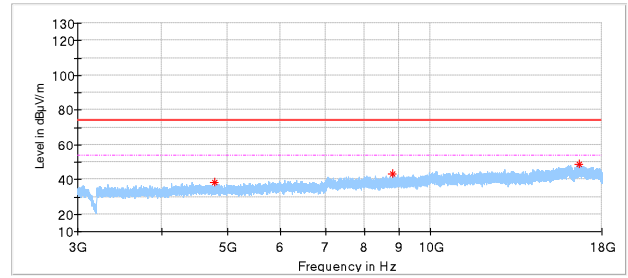
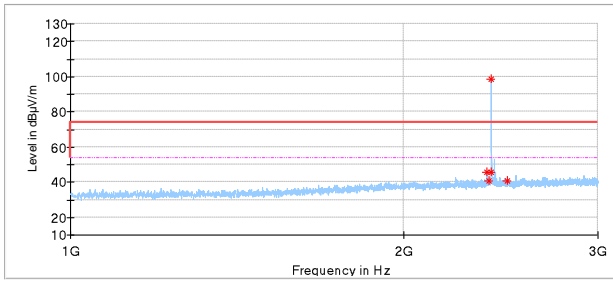

Frequency (MHz)	MaxPeak (dBµV/m)	Limit (dBµV/m)	Margin (dB)	Height (cm)	Pol	Azimuth (deg)	Corr. (dB/m)
2380.476191	45.51	74.00	28.49	150.0	H	220.0	-3.87
2389.523810	40.85	74.00	33.15	150.0	H	91.0	-3.90
2399.523810	45.97	74.00	28.03	150.0	H	149.0	-3.94
2402.380952	98.43	74.00	-24.43	150.0	H	149.0	-3.94
2483.809524	40.69	74.00	33.31	150.0	H	97.0	-3.70
4796.000000	38.35	74.00	35.65	150.0	H	62.0	1.08
8818.500000	43.07	74.00	30.93	150.0	H	285.0	6.44
16634.000000	48.50	74.00	25.50	150.0	H	335.0	15.81

Vertical

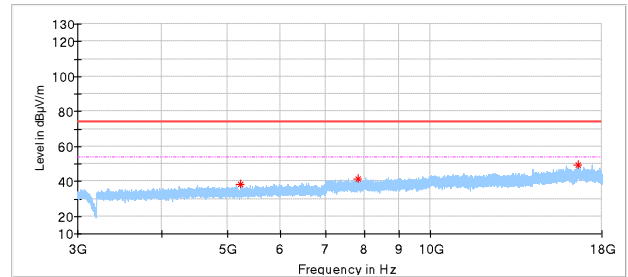
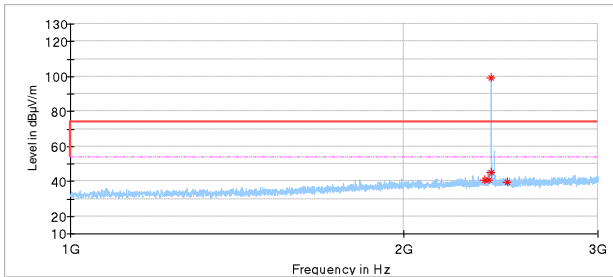

Frequency (MHz)	MaxPeak (dBµV/m)	Limit (dBµV/m)	Margin (dB)	Height (cm)	Pol	Azimuth (deg)	Corr. (dB/m)
2367.142857	40.79	74.00	33.21	150.0	V	25.0	-3.89
2390.000000	40.72	74.00	33.28	150.0	V	272.0	-3.90
2399.523810	45.06	74.00	28.94	150.0	V	252.0	-3.94
2402.380952	99.10	74.00	-25.10	150.0	V	240.0	-3.94
2483.333333	39.74	74.00	34.26	150.0	V	0.0	-3.70
5236.500000	38.34	74.00	35.66	150.0	V	85.0	1.70
7812.000000	41.58	74.00	32.42	150.0	V	224.0	5.74
16597.000000	49.51	74.00	24.49	150.0	V	356.0	15.75

BLE\_1M-2440MHz:  
Horizontal:

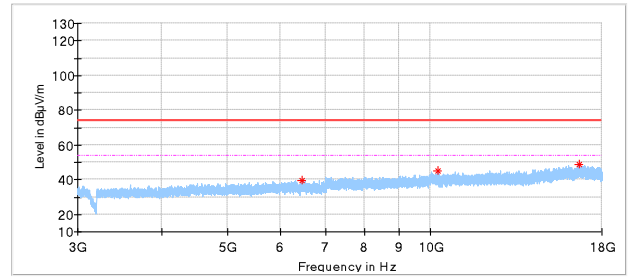
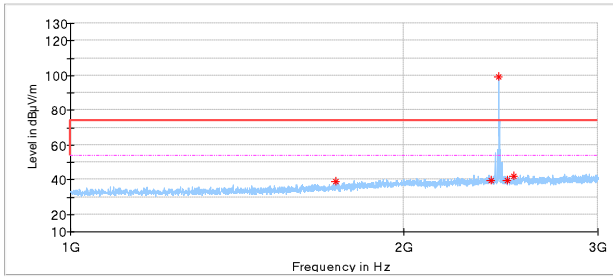

Frequency (MHz)	MaxPeak (dBµV/m)	Limit (dBµV/m)	Margin (dB)	Height (cm)	Pol	Azimuth (deg)	Corr. (dB/m)
1738.571429	38.69	74.00	35.31	150.0	H	232.0	-6.82
2399.523810	39.79	74.00	34.21	150.0	H	200.0	-3.94
2440.476191	99.20	74.00	-25.20	150.0	H	213.0	-3.86
2483.809524	39.80	74.00	34.20	150.0	H	258.0	-3.70
2518.571429	41.72	74.00	32.28	150.0	H	239.0	-3.67
6470.500000	39.57	74.00	34.43	150.0	H	196.0	4.37
10265.000000	45.31	74.00	28.69	150.0	H	252.0	8.97
16662.500000	48.77	74.00	25.23	150.0	H	252.0	15.86

Vertical

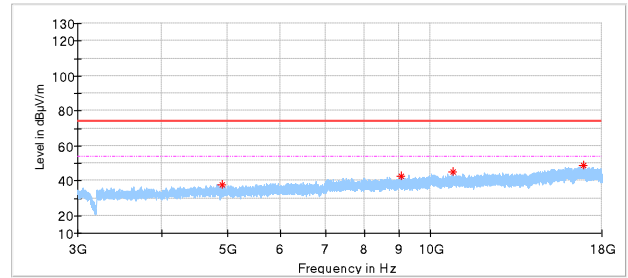
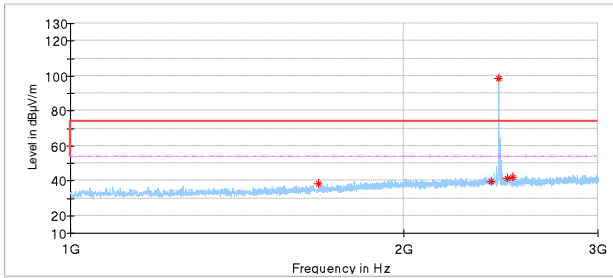

Frequency (MHz)	MaxPeak (dBµV/m)	Limit (dBµV/m)	Margin (dB)	Height (cm)	Pol	Azimuth (deg)	Corr. (dB/m)
1677.142857	38.11	74.00	35.89	150.0	V	51.0	-7.35
2400.000000	39.50	74.00	34.50	150.0	V	297.0	-3.94
2440.000000	98.69	74.00	-24.69	150.0	V	230.0	-3.86
2483.333333	41.17	74.00	32.83	150.0	V	166.0	-3.70
2511.428571	41.98	74.00	32.02	150.0	V	348.0	-3.68
4922.000000	37.42	74.00	36.58	150.0	V	356.0	1.10
9061.000000	42.87	74.00	31.13	150.0	V	77.0	6.78
10838.500000	45.37	74.00	28.64	150.0	V	305.0	8.44
16937.500000	48.48	74.00	25.52	150.0	V	105.0	16.48

BLE\_1M-2480MHz  
Horizontal:

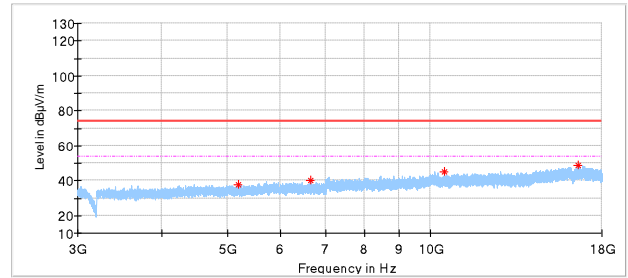
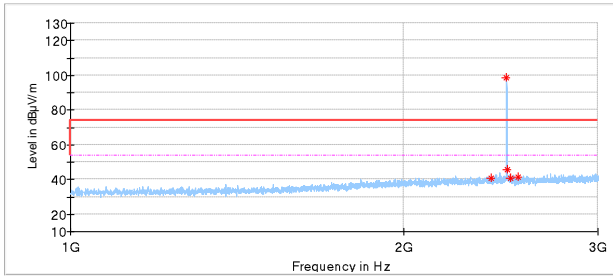

Frequency (MHz)	MaxPeak (dBµV/m)	Limit (dBµV/m)	Margin (dB)	Height (cm)	Pol	Azimuth (deg)	Corr. (dB/m)
2400.476191	40.98	74.00	33.02	150.0	H	327.0	-3.94
2480.476191	98.46	74.00	-24.46	150.0	H	230.0	-3.70
2483.333333	45.56	74.00	28.44	150.0	H	250.0	-3.70
2500.476191	40.92	74.00	33.08	150.0	H	355.0	-3.70
2541.428571	41.31	74.00	32.69	150.0	H	115.0	-3.63
5188.000000	37.93	74.00	36.07	150.0	H	356.0	1.59
6658.500000	40.16	74.00	33.84	150.0	H	356.0	4.54
10490.500000	45.25	74.00	28.75	150.0	H	305.0	8.58
16620.500000	48.99	74.00	25.01	150.0	H	305.0	15.79

Vertical

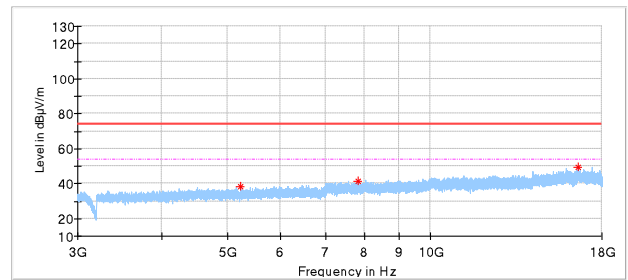
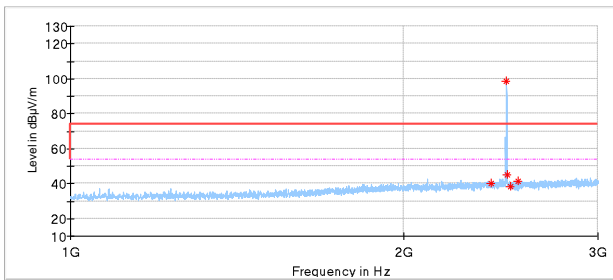

Frequency (MHz)	MaxPeak (dBµV/m)	Limit (dBµV/m)	Margin (dB)	Height (cm)	Pol	Azimuth (deg)	Corr. (dB/m)
2400.000000	40.09	74.00	33.91	150.0	V	46.0	-3.94
2480.476191	98.83	74.00	-24.83	150.0	V	232.0	-3.70
2483.333333	44.96	74.00	29.04	150.0	V	232.0	-3.70
2499.523810	38.59	74.00	35.41	150.0	V	72.0	-3.71
2539.523810	41.46	74.00	32.54	150.0	V	303.0	-3.64
5236.500000	38.34	74.00	35.66	150.0	V	85.0	1.70
7812.000000	41.58	74.00	32.42	150.0	V	224.0	5.74
16597.000000	49.51	74.00	24.49	150.0	V	356.0	15.75

1GHz -18GHz:  
BLE\_2M-2402MHz  
Horizontal:

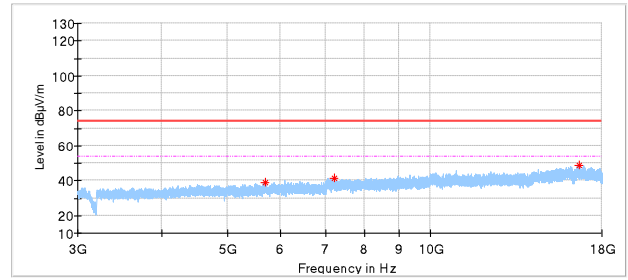
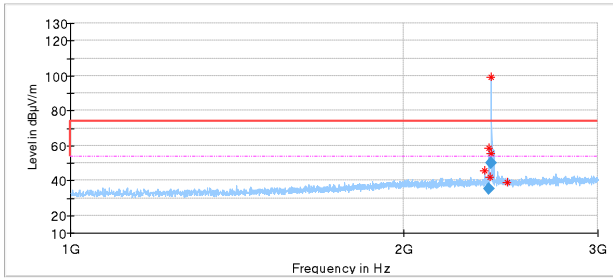

Frequency (MHz)	MaxPeak (dBµV/m)	Limit (dBµV/m)	Margin (dB)	Height (cm)	Pol	Azimuth (deg)	Corr. (dB/m)
2369.523810	45.62	74.00	28.38	150.0	H	173.0	-3.88
2389.523810	58.59	74.00	15.41	150.0	H	179.0	-3.90
2398.571429	42.16	74.00	31.84	150.0	H	140.0	-3.93
2399.523810	55.34	74.00	18.66	150.0	H	230.0	-3.94
2402.380952	99.09	74.00	-25.09	150.0	H	147.0	-3.94
2483.809524	38.89	74.00	35.11	150.0	H	301.0	-3.70
5706.500000	38.97	74.00	35.03	150.0	H	275.0	2.98
7220.500000	41.28	74.00	32.72	150.0	H	0.0	5.21
16689.000000	48.88	74.00	25.12	150.0	H	334.0	15.90
Frequency	Average	Limit	Margin	Height	Pol	Azimuth	Corr.
2389.523810	35.20	54.00	18.80	150.0	H	179.0	-3.90
2399.523810	50.20	54.00	3.80	150.0	H	230.0	-3.94

Vertical

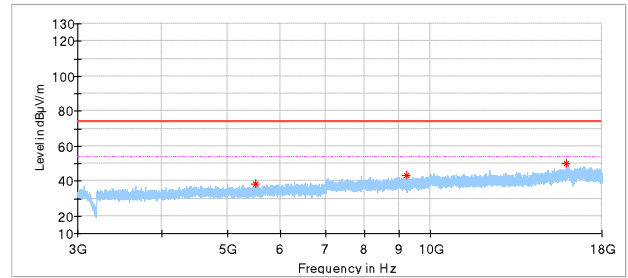
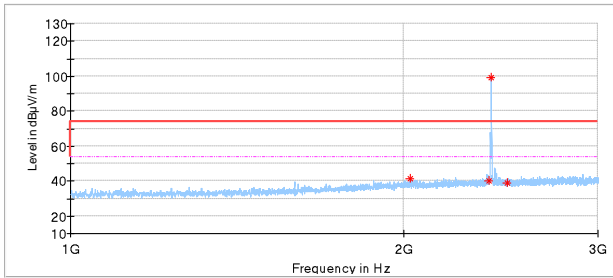

Frequency (MHz)	MaxPeak (dBµV/m)	Limit (dBµV/m)	Margin (dB)	Height (cm)	Pol	Azimuth (deg)	Corr. (dB/m)
2029.047619	41.27	74.00	32.73	150.0	V	230.0	-4.92
2390.000000	40.15	74.00	33.85	150.0	V	269.0	-3.90
2402.857143	99.15	74.00	-25.15	150.0	V	243.0	-3.94
2483.333333	39.02	74.00	34.98	150.0	V	243.0	-3.70
5514.000000	38.56	74.00	35.44	150.0	V	140.0	2.39
9240.500000	43.44	74.00	30.56	150.0	V	0.0	6.82
15932.000000	49.96	74.00	24.04	150.0	V	55.0	14.02



BLE\_2M-2440MHz:  
Horizontal:

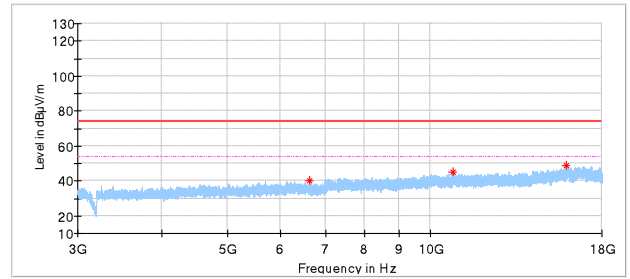
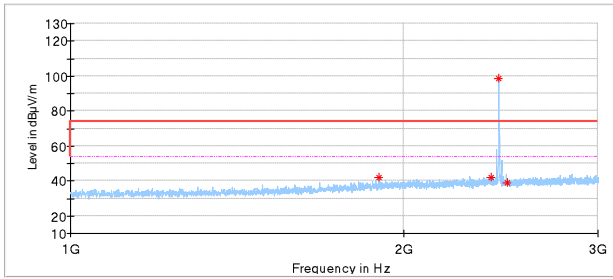

Frequency (MHz)	MaxPeak (dBµV/m)	Limit (dBµV/m)	Margin (dB)	Height (cm)	Pol	Azimuth (deg)	Corr. (dB/m)
1900.000000	42.28	74.00	31.72	150.0	H	24.0	-5.58
2400.000000	41.88	74.00	32.12	150.0	H	352.0	-3.94
2440.952381	98.51	74.00	-24.51	150.0	H	149.0	-3.86
2483.333333	38.79	74.00	35.21	150.0	H	271.0	-3.70
6639.000000	40.25	74.00	33.75	150.0	H	77.0	4.52
10840.500000	44.95	74.00	29.05	150.0	H	305.0	8.44
15923.500000	48.58	74.00	25.42	150.0	H	3.0	13.97

Vertical

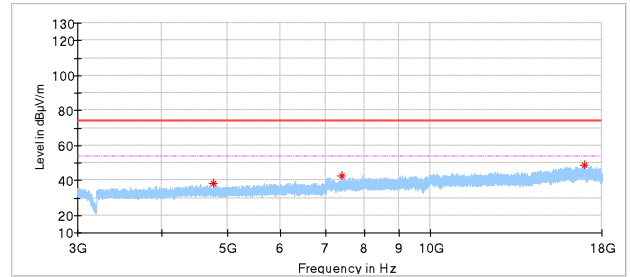
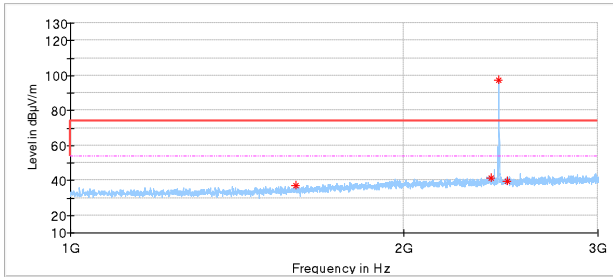

Frequency (MHz)	MaxPeak (dBµV/m)	Limit (dBµV/m)	Margin (dB)	Height (cm)	Pol	Azimuth (deg)	Corr. (dB/m)
1600.476191	36.77	74.00	37.23	150.0	V	170.0	-7.97
2399.523810	41.34	74.00	32.66	150.0	V	26.0	-3.94
2440.476191	97.21	74.00	-23.21	150.0	V	241.0	-3.86
2483.809524	39.64	74.00	34.36	150.0	V	354.0	-3.70
4766.000000	38.06	74.00	35.94	150.0	V	4.0	1.03
7413.000000	42.35	74.00	31.65	150.0	V	0.0	5.53
16991.000000	48.52	74.00	25.48	150.0	V	116.0	16.41

BLE\_2M-2480MHz  
Horizontal:

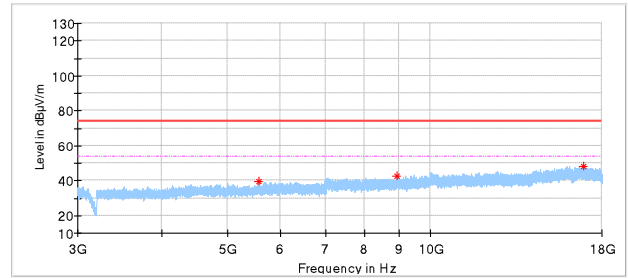
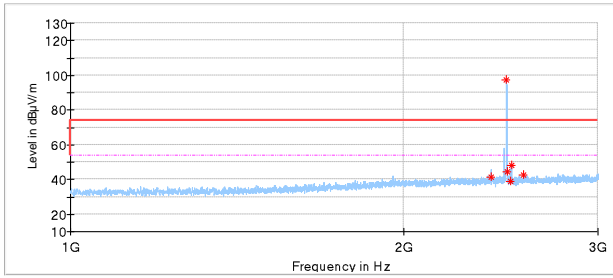

Frequency (MHz)	MaxPeak (dBµV/m)	Limit (dBµV/m)	Margin (dB)	Height (cm)	Pol	Azimuth (deg)	Corr. (dB/m)
2399.523810	41.16	74.00	32.84	150.0	H	344.0	-3.94
2480.000000	97.43	74.00	-23.43	150.0	H	180.0	-3.70
2483.809524	44.46	74.00	29.54	150.0	H	160.0	-3.70
2499.523810	38.62	74.00	35.38	150.0	H	322.0	-3.71
2506.190476	48.07	74.00	25.93	150.0	H	168.0	-3.69
2568.095238	42.32	74.00	31.68	150.0	H	63.0	-3.49
5570.500000	39.42	74.00	34.58	150.0	H	113.0	2.53
8929.000000	42.78	74.00	31.22	150.0	H	26.0	6.49
16933.000000	48.36	74.00	25.64	150.0	H	252.0	16.48

Vertical

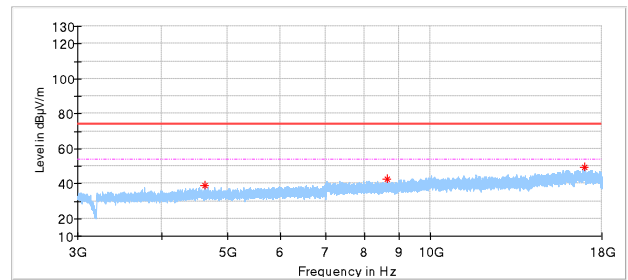
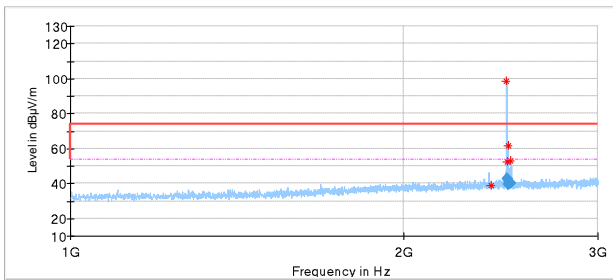

Frequency (MHz)	MaxPeak (dBµV/m)	Limit (dBµV/m)	Margin (dB)	Height (cm)	Pol	Azimuth (deg)	Corr. (dB/m)
2399.523810	39.08	74.00	34.92	150.0	V	220.0	-3.94
2480.000000	98.34	74.00	-24.34	150.0	V	239.0	-3.70
2483.333333	52.30	74.00	21.70	150.0	V	245.0	-3.70
2489.523810	61.95	74.00	12.05	150.0	V	264.0	-3.70
2500.000000	39.85	74.00	34.15	150.0	V	146.0	-3.71
2502.857143	53.31	74.00	20.69	150.0	V	232.0	-3.70
2399.523810	39.08	74.00	34.92	150.0	V	220.0	-3.94
4640.000000	38.69	74.00	35.31	150.0	V	356.0	0.81
8630.500000	42.87	74.00	31.13	150.0	V	0.0	6.44
16960.000000	49.14	74.00	24.86	150.0	V	220.0	16.45
Frequency	Average	Limit	Margin	Height	Pol	Azimuth	Corr.
2483.333333	42.50	54.00	11.50	150.0	V	245.0	-3.70
2489.523810	39.80	54.00	14.20	150.0	V	264.0	-3.70
2502.857143	40.40	54.00	13.60	150.0	V	232.0	-3.70

18GHz- 40GHz:  
 BLE\_1M\_2402MHz:  
 Horizontal:

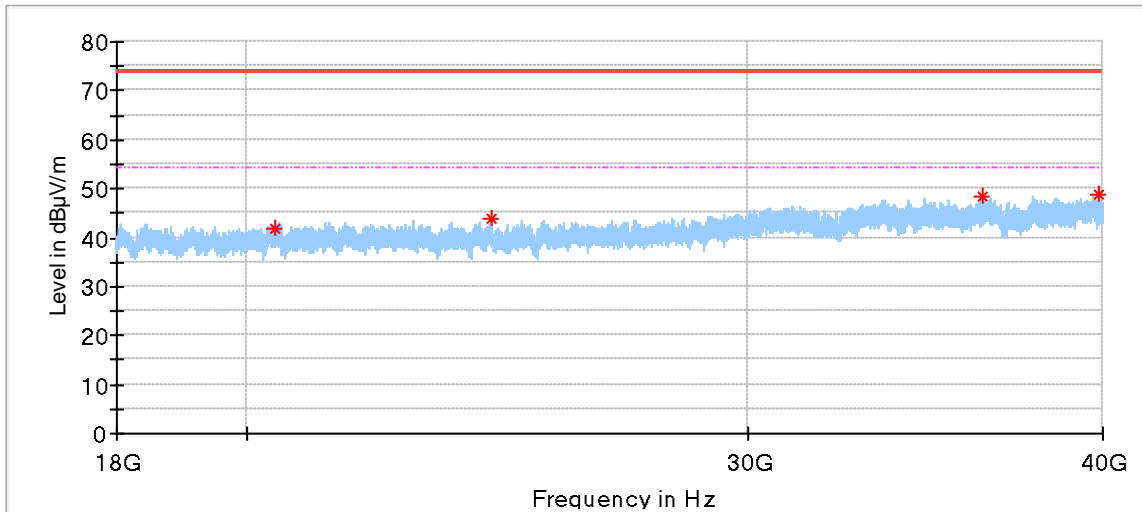

Frequency (MHz)	MaxPeak (dBµV/m)	Limit (dBµV/m)	Margin (dB)	Height (cm)	Pol	Azimuth (deg)	Corr. (dB/m)
20464.000000	42.02	74.00	31.98	150.0	H	1.0	-0.55
24366.937500	44.02	74.00	29.98	150.0	H	218.0	1.19
36288.187500	48.52	74.00	25.48	150.0	H	124.0	6.08
39893.437500	48.62	74.00	25.38	150.0	H	191.0	9.85

Vertical:

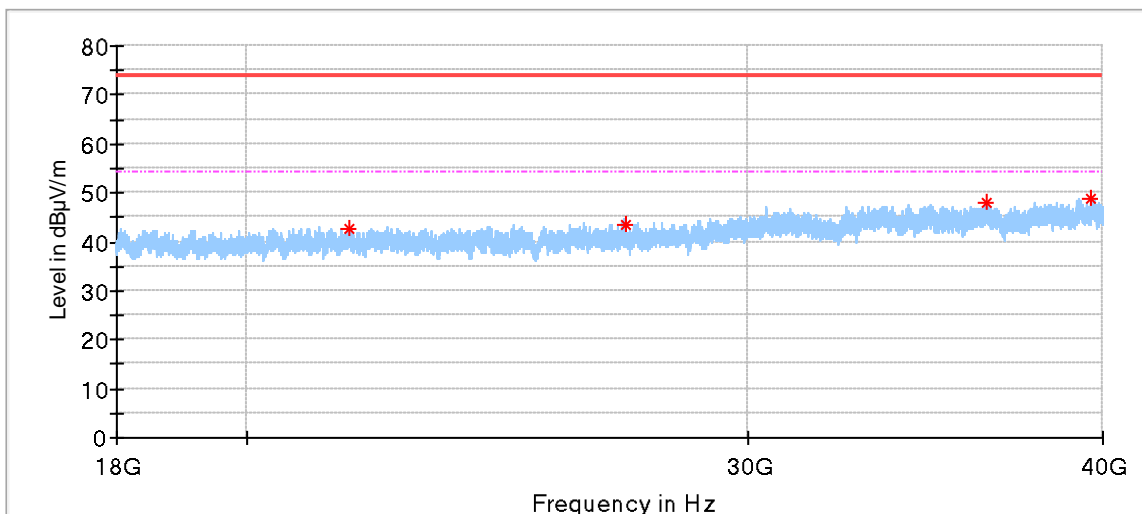

Frequency (MHz)	MaxPeak (dBµV/m)	Limit (dBµV/m)	Margin (dB)	Height (cm)	Pol	Azimuth (deg)	Corr. (dB/m)
21743.437500	42.74	74.00	31.26	150.0	V	319.0	0.48
27178.125000	43.66	74.00	30.34	150.0	V	188.0	2.23
36402.312500	48.16	74.00	25.84	150.0	V	203.0	6.19
39603.312500	48.87	74.00	25.13	150.0	V	127.0	9.03

BLE\_1M\_2440MHz:  
Horizontal:

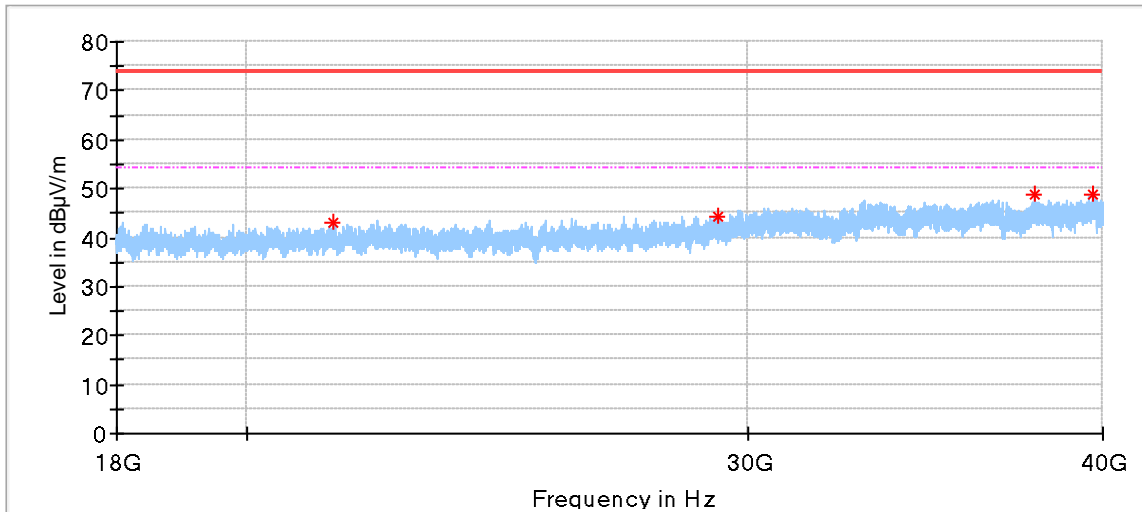

Frequency (MHz)	MaxPeak (dBµV/m)	Limit (dBµV/m)	Margin (dB)	Height (cm)	Pol	Azimuth (deg)	Corr. (dB/m)
21458.812500	42.88	74.00	31.12	150.0	H	354.0	0.30
29273.625000	44.36	74.00	29.64	150.0	H	354.0	2.24
37860.500000	48.95	74.00	25.05	150.0	H	31.0	6.73
39692.687500	48.72	74.00	25.28	150.0	H	1.0	9.28

Vertical:

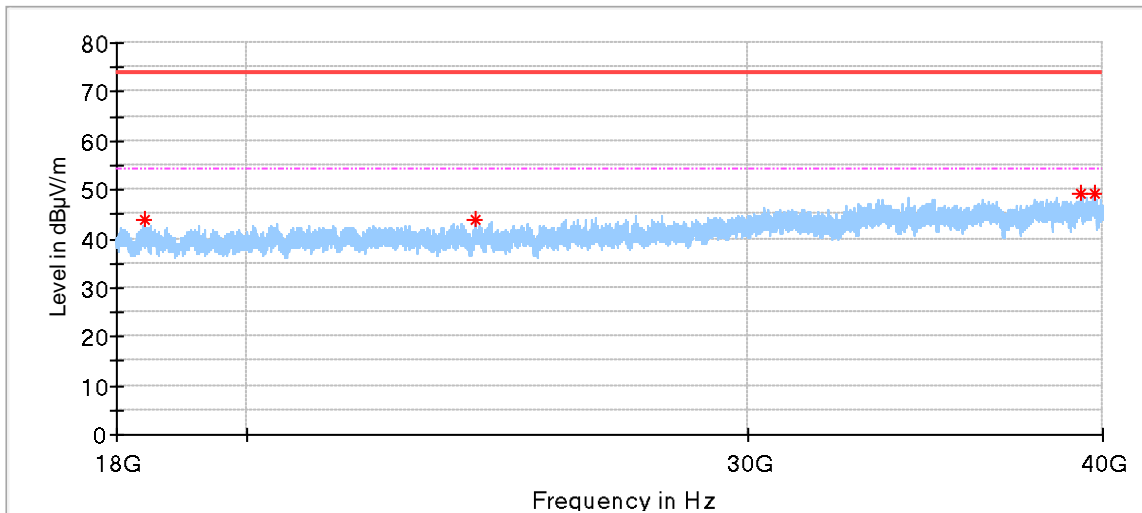

Frequency (MHz)	MaxPeak (dBµV/m)	Limit (dBµV/m)	Margin (dB)	Height (cm)	Pol	Azimuth (deg)	Corr. (dB/m)
18417.312500	44.00	74.00	30.00	150.0	V	185.0	-1.91
24059.625000	43.84	74.00	30.16	150.0	V	345.0	1.14
39323.500000	49.29	74.00	24.71	150.0	V	284.0	8.15
39757.312500	49.29	74.00	24.71	150.0	V	299.0	9.47

BLE\_1M\_2480MHz:  
Horizontal:

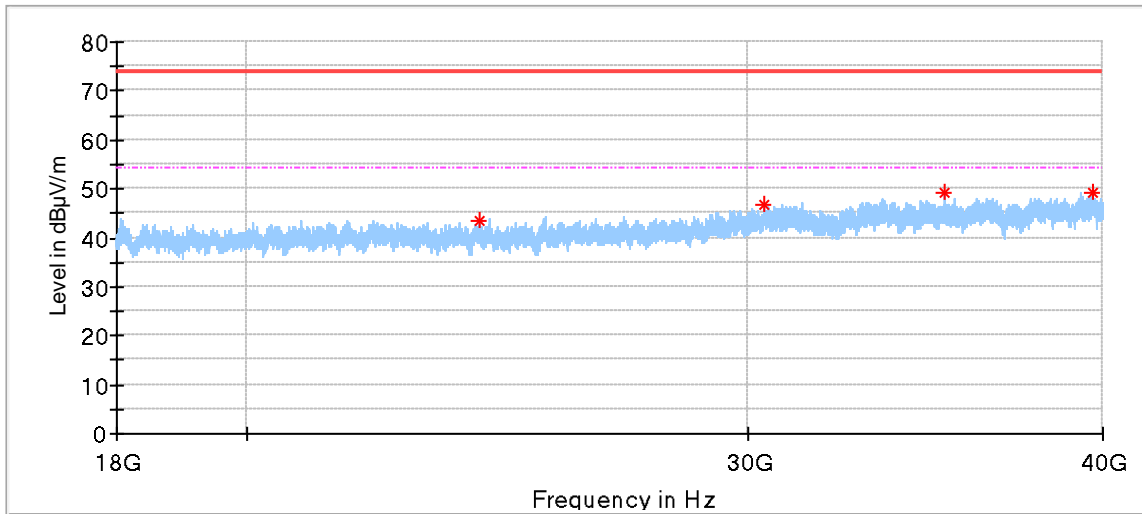

Frequency (MHz)	MaxPeak (dBµV/m)	Limit (dBµV/m)	Margin (dB)	Height (cm)	Pol	Azimuth (deg)	Corr. (dB/m)
24143.500000	43.57	74.00	30.43	150.0	H	31.0	1.11
30415.562500	46.66	74.00	27.34	150.0	H	355.0	3.06
35162.750000	49.31	74.00	24.69	150.0	H	48.0	5.49
39674.812500	49.32	74.00	24.68	150.0	H	233.0	9.23

Vertical:

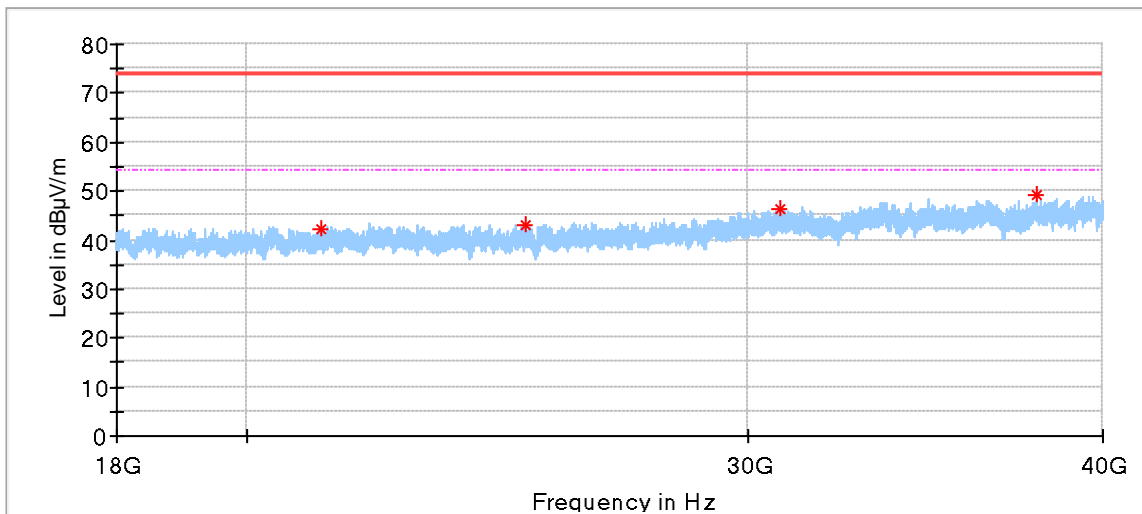

Frequency (MHz)	MaxPeak (dBµV/m)	Limit (dBµV/m)	Margin (dB)	Height (cm)	Pol	Azimuth (deg)	Corr. (dB/m)
21244.312500	42.19	74.00	31.81	150.0	V	183.0	0.27
25055.812500	43.00	74.00	31.00	150.0	V	199.0	1.76
30777.875000	46.31	74.00	27.69	150.0	V	305.0	2.95
37922.375000	49.18	74.00	24.82	150.0	V	67.0	6.89

BLE\_2M\_2402MHz:  
Horizontal:

Frequency (MHz)	MaxPeak (dBμV/m)	Limit (dBμV/m)	Margin (dB)	Height (cm)	Pol	Azimuth (deg)	Corr. (dB/m)
18144.500000	43.94	74.00	30.06	100.0	H	3.0	-2.2
19441.000000	41.60	74.00	32.40	100.0	H	17.0	-1.9
20530.000000	41.79	74.00	32.21	100.0	H	210.0	-0.8
21120.500000	40.23	74.00	33.77	100.0	H	0.0	-0.3
22154.000000	42.73	74.00	31.27	100.0	H	343.0	0.3
23756.250000	44.22	74.00	29.78	100.0	H	60.0	1.1

Vertical:

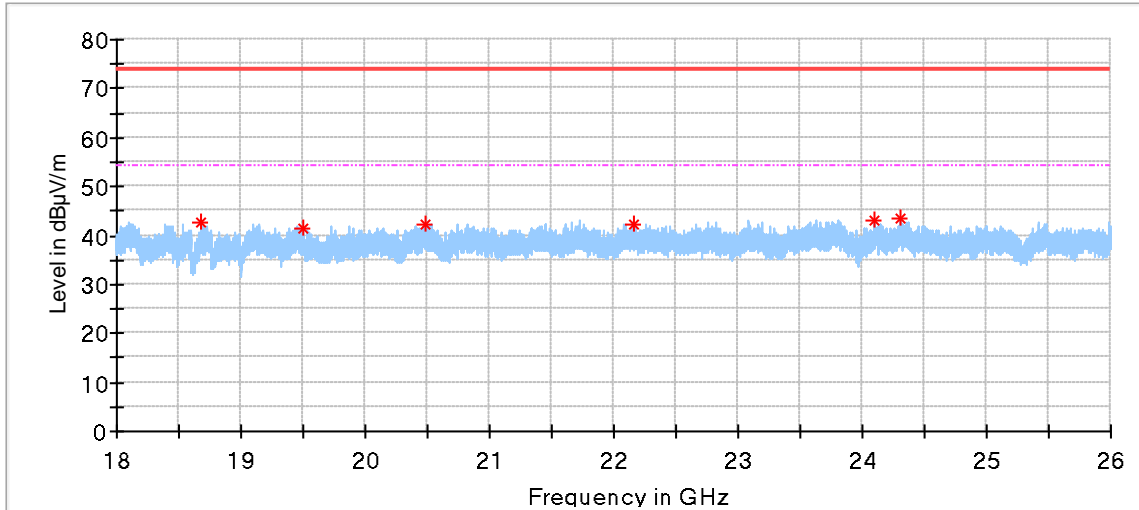

Frequency (MHz)	MaxPeak (dBμV/m)	Limit (dBμV/m)	Margin (dB)	Height (cm)	Pol	Azimuth (deg)	Corr. (dB/m)
18679.250000	42.54	74.00	31.46	100.0	V	240.0	-2.1
19501.500000	41.50	74.00	32.50	100.0	V	181.0	-1.9
20477.000000	42.30	74.00	31.70	100.0	V	111.0	-0.8
22160.000000	42.05	74.00	31.95	100.0	V	0.0	0.4
24104.500000	43.20	74.00	30.80	100.0	V	30.0	0.7
24311.000000	43.36	74.00	30.64	100.0	V	273.0	1.1

BLE\_2M\_2440MHz:  
Horizontal:

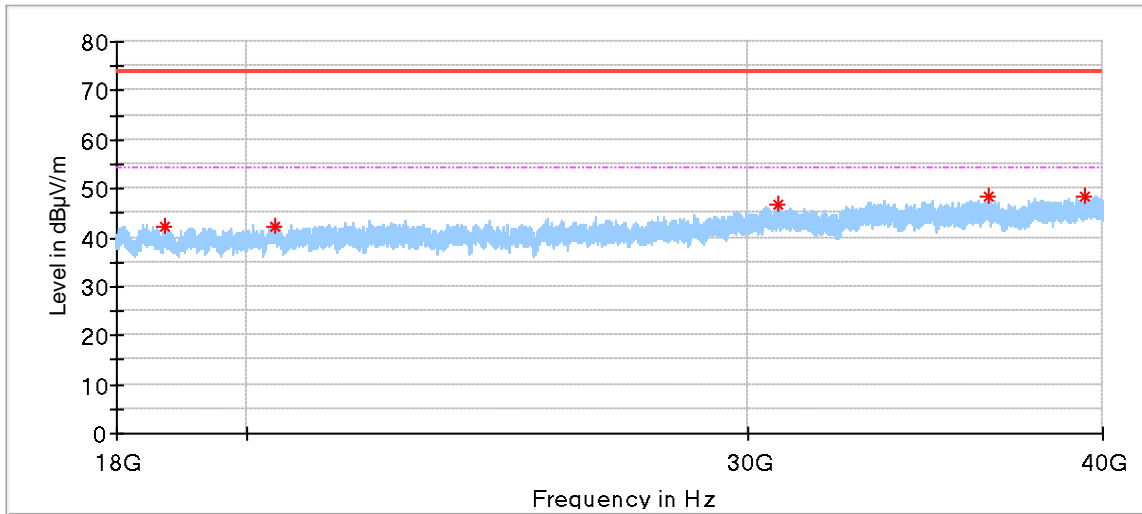

Frequency (MHz)	MaxPeak (dBµV/m)	Limit (dBµV/m)	Margin (dB)	Height (cm)	Pol	Azimuth (deg)	Corr. (dB/m)
18728.062500	42.25	74.00	31.75	150.0	H	44.0	-1.92
20461.937500	42.31	74.00	31.69	150.0	H	145.0	-0.56
30748.312500	46.84	74.00	27.16	150.0	H	191.0	2.97
36440.812500	48.39	74.00	25.61	150.0	H	1.0	6.23
39441.062500	48.42	74.00	25.58	150.0	H	199.0	8.54

Vertical:

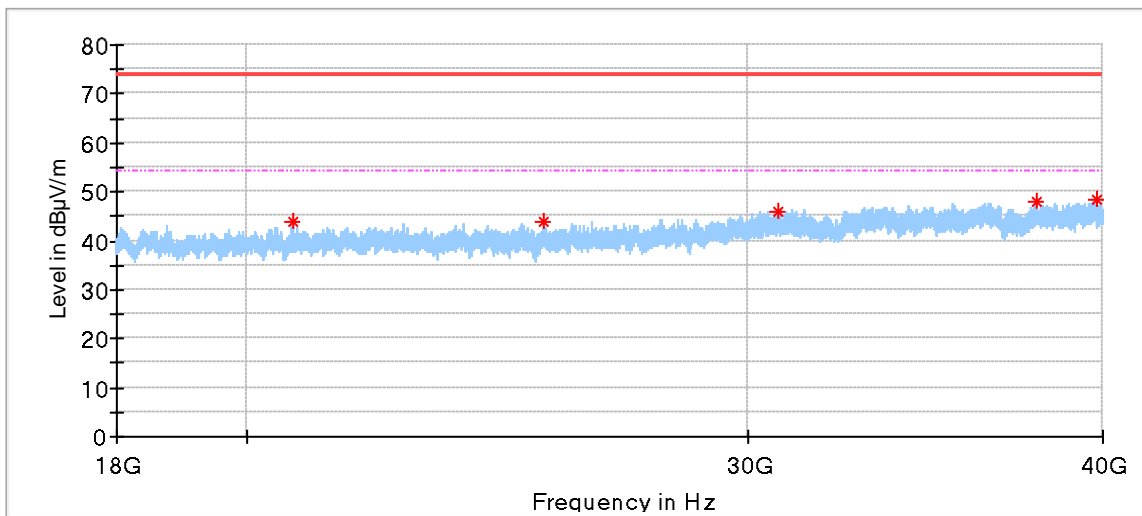

Frequency (MHz)	MaxPeak (dBµV/m)	Limit (dBµV/m)	Margin (dB)	Height (cm)	Pol	Azimuth (deg)	Corr. (dB/m)
20758.937500	43.80	74.00	30.20	150.0	V	86.0	-0.26
25449.750000	43.87	74.00	30.13	150.0	V	4.0	1.83
30735.250000	45.87	74.00	28.13	150.0	V	208.0	2.98
37893.500000	47.91	74.00	26.09	150.0	V	261.0	6.82
39810.937500	48.41	74.00	25.59	150.0	V	216.0	9.62

BLE\_2M\_2480MHz:  
Horizontal:

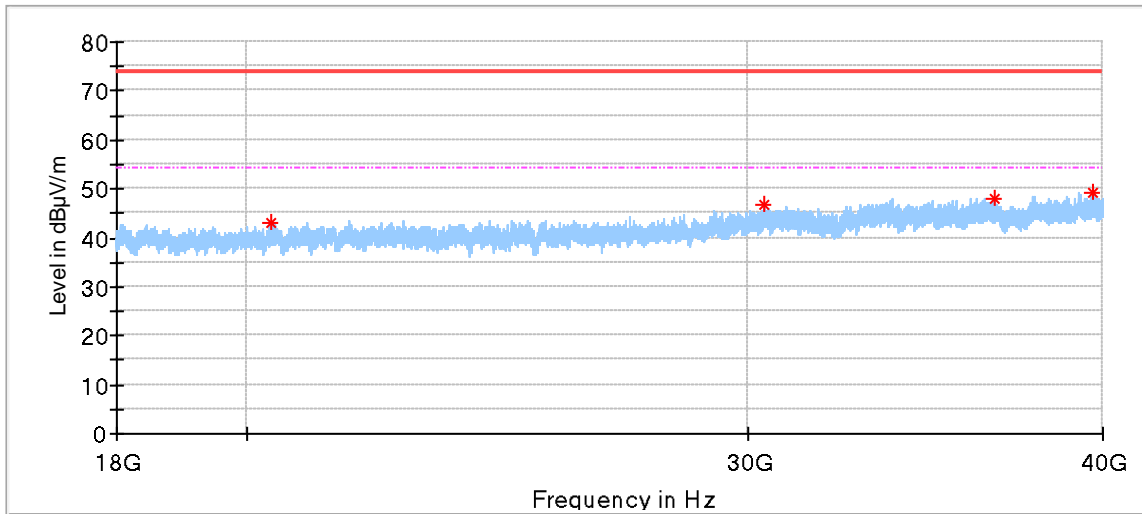

Frequency (MHz)	MaxPeak (dBµV/m)	Limit (dBµV/m)	Margin (dB)	Height (cm)	Pol	Azimuth (deg)	Corr. (dB/m)
20398.687500	42.99	74.00	31.01	150.0	H	107.0	-0.67
30407.312500	46.56	74.00	27.44	150.0	H	61.0	3.05
36660.812500	48.14	74.00	25.86	150.0	H	284.0	6.14
39692.000000	49.22	74.00	24.78	150.0	H	0.0	9.28

Vertical:

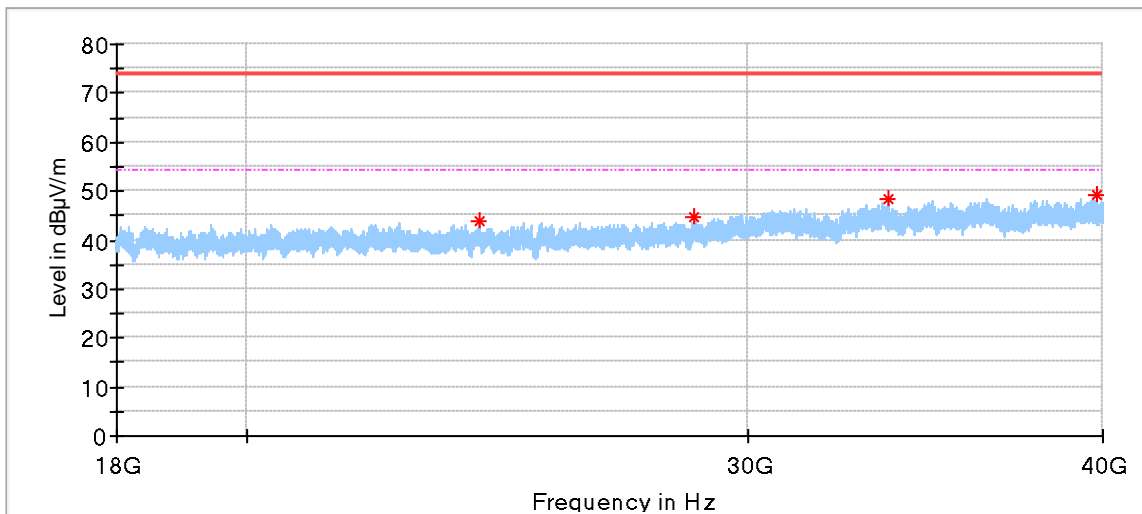

Frequency (MHz)	MaxPeak (dBµV/m)	Limit (dBµV/m)	Margin (dB)	Height (cm)	Pol	Azimuth (deg)	Corr. (dB/m)
24144.187500	43.87	74.00	30.13	150.0	V	7.0	1.11
28703.687500	44.52	74.00	29.48	150.0	V	213.0	2.40
33646.125000	48.30	74.00	25.70	150.0	V	236.0	4.56
39813.687500	49.36	74.00	24.64	150.0	V	228.0	9.63

Remark:

- Corrected Amplitude = Read level + Corrector factor  
 Above 1GHz: Corrector factor = Antenna Factor + Cable Loss- Amplifier Gain  
 Below 1GHz: Corrector factor = Antenna Factor + Cable Loss  
 (The Reading Level is recorded by software which is not shown in the sheet)



## 10 Test Equipment List

### List of Test Instruments

#### Radiated Emission Test

DESCRIPTION	MANUFACTURER	MODEL NO.	SERIAL NO.	CAL. DUE DATE
EMI Test Receiver	Rohde & Schwarz	ESR 26	101269	2021-6-29
Trilog Super Broadband Test Antenna	Schwarzbeck	VULB 9163	707	2021-8-4
Horn Antenna	Rohde & Schwarz	HF907	102294	2021-7-14
Pre-amplifier	Rohde & Schwarz	SCU 18	102230	2021-6-21
Signal Generator	Rohde & Schwarz	SMY01	839369/005	2021-6-21
Attenuator	Agilent	8491A	MY39264334	2022-10-28
3m Semi-anechoic chamber	TDK	9X6X6	----	N/A

#### Conducted RF Test System

DESCRIPTION	MANUFACTURER	MODEL NO.	SERIAL NO.	CAL. DUE DATE
Signal Analyzer	Rohde & Schwarz	FSV40	101030	2021-6-21
RF Switch Module	Rohde & Schwarz	OSP120/OSP-B157	101226/100851	2021-6-21
Power Splitter	Weinschel	1580	SC319	2021-7-16
Test software	Tonscend	System for BT/WIFI	Version 2.5.77.0418	N/A

#### Conducted Emission Test

DESCRIPTION	MANUFACTURER	MODEL NO.	SERIAL NO.	CAL. DUE DATE
EMI Test Receiver	Rohde & Schwarz	ESR 3	101782	2021-6-29
LISN	Rohde & Schwarz	ENV4200	100249	2021-6-12
Attenuator	Shanghai Huaxiang	TS2-26-3	080928189	2021-6-21
Test software	Rohde & Schwarz	EMC32	Version9.15.00	N/A

## 11 System Measurement Uncertainty

For a 95% confidence level, the measurement expanded uncertainties for defined systems, in accordance with the recommendations of ISO 17025 were:

System Measurement Uncertainty	
Test Items	Extended Uncertainty
Uncertainty for Radiated Emission in new 3m chamber (68-4-90-19-006) 30MHz-1000MHz	Horizontal: 4.70dB; Vertical: 4.67dB;
Uncertainty for Radiated Emission in new 3m chamber (68-4-90-19-006) 1000MHz-18000MHz	Horizontal: 4.65dB; Vertical: 4.63dB;
Uncertainty for Radiated Spurious Emission 18000MHz-40000MHz	Horizontal: 4.89dB; Vertical: 4.87dB;
Uncertainty for Conducted Emission in shielding room (68-4-90-19-004) 150kHz-30MHz (for test using AMN ENV432 or ENV4200)	3.21dB
Uncertainty for Conducted RF test with TS 8997	RF Power Conducted: 1.16dB Frequency test involved: $0.6 \times 10^{-7}$ or 1%